

5772 ✓

NASA Technical Memorandum 86809

---

# X-29A Technology Demonstrator Flight Test Program Overview

---

Walter J. Sefic and Cleo M. Maxwell

---

(NASA-TM-86809) X-29A TECHNOLOGY  
DEMONSTRATOR FLIGHT TEST PROGRAM OVERVIEW  
(NASA) 17 p HC A02/MF A01 CSCL 01C

N86-26328

Unclas  
G3/05 43095

May 1986

---

# **X-29A Technology Demonstrator Flight Test Program Overview**

---

Walter J. Sefic and Cleo M. Maxwell  
Ames Research Center, Dryden Flight Research Facility, Edwards, California

1986



National Aeronautics and  
Space Administration

**Ames Research Center**

Dryden Flight Research Facility

Edwards, California 93523

## X-29A TECHNOLOGY DEMONSTRATOR FLIGHT TEST PROGRAM OVERVIEW

Walter J. Sefic  
X-29A Project Manager  
NASA Ames Research Center  
Dryden Flight Research Facility  
Edwards, California

Cleo M. Maxwell  
X-29A Test Information Engineer  
NASA Ames Research Center  
Dryden Flight Research Facility  
Edwards, California

### ABSTRACT

This paper presents an overview of the X-29A functional flight program and concept evaluation program, including some of the unique and different preparations for the first flight. Included are a discussion of the many organizational responsibilities and a description of the program management structure for the test team comprised of NASA, U.S. Air Force, and Grumman Corporation personnel. Also discussed are pre-flight ground, flight functional, envelope expansion, and flight research test objectives and qualitative results to date for both a limited-envelope flight control system and an expanded-envelope system.

A brief description of the aircraft, including the instrumentation system and measurements, is also presented. In addition, a discussion is included regarding the use of major support facilities, such as ground and flight simulators, the NASA Western Aeronautical Test Range and mission control center, and the Grumman automated telemetry station linked to the test site by means of a satellite data link. An overview of the associated real-time and postflight batch data processing software approaches is presented. The use of hardware-in-the-loop simulation for independent verification and validation and mission planning and practice is discussed.

A discussion is included regarding the approach to flight operations for the X-29A that was used by the Dryden Flight Research Facility of NASA Ames Research Center. Also included is a description of the flight-readiness review, the airworthiness and flight safety review, work scheduling, technical briefings, and preflight and postflight crew briefings. The configuration control process used on the X-29A program is described, and its relationship to both simulation and aircraft operations is discussed. An X-29A schedule overview is presented with an outline of a proposed follow-on program.

### INTRODUCTION

In the late 1970's, the Defense Advanced Research Project Agency (DARPA) sponsored various studies

to determine if it was feasible to build and flight test a forward-swept wing (FSW) aircraft. Results of the feasibility studies were favorable, and a program consisting of preliminary design, final design, fabrication, and limited-envelope flight testing was initiated. The potential advantages of an aircraft with an FSW were identified during these initial studies:

1. Improved lateral control at high angles of attack resulting from inboard spanwise flow and subsequent delayed wingtip stall.
2. A reduction in wing profile drag for the FSW, as compared with an aft-swept wing with the same shock sweep angle, that results in a 13-percent reduction in total drag.
3. A decrease in wing structural box weight or an increase in aerodynamic efficiency resulting from the geometric differences in FSW and aft-swept wing designs with the same shock sweep angle.
4. Increased fuselage design freedom with aft placement of the wingbox that permits more effective fuselage contouring to minimize wave drag.
5. Reduced trim drag resulting from less wing twist required with an FSW design. Less wing twist also reduces manufacturing complexity and cost.

The experimental aircraft that was built as a result of the DARPA studies was named the X-29A. During preliminary design efforts, DARPA management stressed that other advanced technologies be incorporated into the aircraft so that the return on investment for any resulting new experimental flight test vehicle could be maximized. These additional technologies, although highly synergistic with the FSW concept, could also be used in comparable aft-swept-wing aircraft.

During the final design and fabrication phase, simulation evaluation aided in ascertaining that the design goal of constant flight control system (FCS) gains for the analog reversion backup mode could not be attained. To expedite the flight schedule while FCS redesign was undertaken, it was

decided first to develop the initial constant gain system and then to evaluate the aircraft with a limited flight envelope with constant analog reversal gains (Figure 1). The full flight envelope FCS was installed in the aircraft in autumn 1985 and is currently being flown.

Using the U.S. Air Force's Aeronautical Systems Division (ASD) as its agent, DARPA contracted Grumman Corporation for two X-29A aircraft. At the same time, DARPA arranged to have the Dryden Flight Research Facility of NASA Ames Research Center (Ames-Dryden) act as the responsible X-29A test organization. The Air Force Flight Test Center (AFFTC) and Grumman agreed to support this effort if DARPA funding was provided. DARPA's overall program goals were to ensure that integrated technologies were made available for the next generation of fighters and to develop the necessary confidence to transition FSW concepts. After completion of fabrication at Grumman facilities in Bethpage, New York, the first X-29A was wrapped in a protective cover, mounted on a container ship, and transported through the Panama Canal to Ames-Dryden for flight tests.

The organizational responsibilities and the agreements between the respective agencies appear to be complex (Figure 2). In actual practice, the working relationship between the various agencies was problem-free; the memoranda of agreement (MOA), the project management directive, and the contracts were filed and were seldom needed to clarify issues.

The objectives for the current phase of the program include envelope expansion for divergence, flutter and loads, the determination of performance and aerodynamic characteristics, and evaluation of the FCS (1).

#### AIRCRAFT DESCRIPTION

The X-29A aircraft (Figure 3) integrates the FSW concept with the following advanced technologies:

1. Graphite-epoxy composite wing covers.
2. Aeroelastically tailored wing.
3. Thin supercritical airfoil cross section.
4. Automatic wing camber control.
5. Full-authority close-coupled canards.
6. Three-surface longitudinal control.
7. Highly relaxed static margin.
8. Digital fly-by-wire control.

The X-29A single-seat fighter-type aircraft employs the FSW with a fixed leading edge sweep of 29.27 deg. The wing aeroelastic tailoring is utilized to control the divergence typically predicted for FSW designs. The wing primary box is

covered with aeroelastically tailored graphite-epoxy covers bolted to aluminum and titanium spars. To optimize aerodynamic efficiency over the flight envelope, dual-hinged, trailing edge flaperons provide high lift during takeoff and landing and during lateral control and programmed variable-camber operations.

The aircraft is approximately 35-percent statically unstable subsonically about the longitudinal axis. Longitudinal control is provided by the combination of the active, all-movable canards, flaperons, and aft-mounted strake flaps. The canards are built-up aluminum assemblies. The single, conventionally constructed vertical fin that employs a rudder for directional control provides directional stability. The surfaces are controlled by an advanced, triple-redundant, digital fly-by-wire FCS.

The aircraft is powered by a single F404-GE-400 turbofan engine with afterburner, rated at 7,258-kg (16,000-lb) thrust at sea level. The side inlets and fuselage accommodate this F-18 flight-proven engine. Aircraft takeoff gross weight is 8,074 kg (17,800 lb), with a fuel capacity of 1,814 kg (4,000 lb). As with the engine, flight-proven equipment is utilized wherever possible to minimize technical risk and investment costs. This includes an F-5A nose section and cockpit, nose gear, and environmental control system, as well as an F-16 main landing gear, emergency power unit, jet fuel starter, aircraft-mounted accessory drive gearbox, and canard-flap-rudder integrated servoactuators.

#### DATA ACQUISITION SYSTEM

To meet the X-29A research objectives, the aircraft is highly instrumented. The sensors include rate gyros, accelerometers, strain gages, aerodynamic pressure taps, temperature and pressure monitors, pitot static monitors, and position indicators for surface positions and movements. Flight data are integrated with data from the 429 data bus onto a single pulse code modulation (PCM) stream.

The X-29A data acquisition system utilizes both PCM and constant-bandwidth FM for data encoding. Because of space constraints on the aircraft, telemetry is the only source of data. The PCM system consists of five remote units operating asynchronously and at different frame rates (Figure 4). Four of the units operate at 800 frames/sec, with each unit having a frame length of 64 words/frame. The fifth unit has a frame rate of 25 frames/sec and a frame length of 512 words. All five units have a word length of 10 bits. The data bus outputs data from the flight control computers. The data bus contains sixty-four 32-bit words with an update rate of 40 words/sec.

The outputs of the PCM units and the data bus are input to an interleaver unit that merges the input data streams and outputs the data in a single 500-kbps serial PCM stream. The PCM output has a

mainframe length of 128 10-bit words. The main frame rate is 400 frames/sec with subframe rates of 200, 100, 50, and 25/sec.

The constant-bandwidth FM system consists of Inter-Range Instrumentation Group (IRIG) channels 1A through 10A with deviation limits of  $\pm 2000$  Hz for encoding high-response acceleration and vibration data. The output of the FM multiplexer is routed to a premodulation mixer where the pilot's voice (hot microphone) is combined with it.

The telemetry transmission system consists of a diplexer, directional coupler, two L-band transmitters, and upper and lower fuselage-mounted L-band antennas. The output of the interleaver modulates one of the transmitters, and the second transmitter is modulated by the FM multiplexer. The transmitter outputs are then diplexed and routed through the directional coupler to the upper and lower L-band antennas.

Figure 5 is a summary of the 503 parameters measured on the aircraft. The locations of the various parameters and block diagrams of the in-flight deflection measurement system are shown in Figures 6 to 9.

The pressure survey instrumentation and optical deflection measurement locations are indicated in Figure 6. There are two rows of pressure orifices on the left canard, four rows on the wing, and one row on the strake. The pressure data are sampled at 25 samples/channel/sec. The optical deflection measurement system is located on the right wing and incorporates a receiver and 12 targets at three span stations. The targets identified by solid triangles in Figure 6 are utilized to determine a reference plane. The optical deflection measurement system is sampled at a rate of 13 samples/channel/sec. A block diagram of the optical deflection measurement system is shown in Figure 7. The system consists of targets that are light-emitting diodes focused on a diode array through a lens; the resulting digitized information is sent to the PCM system.

The locations of static structural loads instrumentation are shown in Figure 8. The data consist of shear, bending moment, and torque measurements at the root of the left and right canard, the fuselage, and vertical tail; shear, bending moment, and torque at four stations on the left wing; actuator loads on all control surfaces; and stick and rudder pedal forces. The structural dynamics instrumentation is shown in Figure 9. Accelerometers are located on both wings, the vertical tail, all control surfaces, and the fuselage. The accelerometers are sampled at a rate of 400 samples/channel/sec.

All data on the X-29A are transmitted to the ground station using the telemetry system (2) shown in Figure 10. During the limited-envelope phase of the program, satellite data transmission to the Grumman facility in Calverton, New York, was provided as indicated in Figure 10.

## OPERATIONS

The basic assumptions made during early planning activities for the X-29A operations were as follows:

1. Flight safety was paramount.
2. The flight rate would be two flights per week.
3. There would be progressive buildup of Mach, altitude, and maneuvering capability.
4. Test planning would include evaluation of flutter and divergence, the FCS, structures, propulsion, aircraft systems, performance, flying qualities, and emergency power unit limits.

The emergency power unit capability limit is central to all flight planning. Under certain circumstances in which complete engine power loss occurs, the aircraft cannot be safely returned to base because of limited emergency power unit hydrazine fuel. The reduced fuel capacity results from the use of a modified F-16 hydrazine tank that was made smaller because of emergency power unit space limitations.

Operations for the X-29A aircraft for a typical sortie include a technical briefing one week in advance, a flight test profile conducted on the simulator, a mission briefing, the actual X-29A flight test, and a mission debriefing. The facilities involved in the typical X-29A program operations include the Western Aeronautical Test Range, the mission control center, spectral analysis, and satellite data transmission. A more detailed description of the operational sequence is shown in Figure 11.

The X-29A operational sequence was initiated with a program plan, flight test plan, and military utility plan. A flight-readiness review (FRR) committee and a flight test team consisting of the Ames-Dryden, AFFTC, and Grumman personnel were formed. The flight test team, employing a project engineer, develops a flight request that results in a number of scheduling activities including configuration control, aircraft maintenance, and simulation that leads to a technical briefing on the proposed flight or group of flights. The technical briefing results in an agreed-to-flight request and an FRR flight release for a first flight or a major modification of the aircraft. After the particular flight is thoroughly conducted on the simulator (including pilot in the loop), a set of final flight cards is briefed, together with the flight operating limits, a mandatory instrumentation list, aircraft configuration, and mission control center layout.

The flight controller is the primary individual communicating with the X-29A pilot and the chase pilot. All other individuals communicate through an intercommunication system to the controller. Under certain conditions, the lead flutter

engineer can communicate directly with the pilot with preplanned commands. After the flight (Figure 11), a postflight briefing is held, data processing is initiated, and any discrepancies are documented and prepared for the next configuration control meeting.

#### CONFIGURATION CONTROL

The configuration control process (Figure 12) consists of change requirements, design, production, and test. The process is initiated by a new system requirement or a discrepancy. Analysis and design are accomplished, and a configuration change request is generated and submitted to the configuration control board. The board members include project management and representatives from each technical discipline; the project manager is the chairman of the board. A hardware configuration change, if approved, requires a work order that results in a modification or fabrication. The hardware change is inspected, documentation is updated, and the system is tested. For an approved software change, a program change notice is generated. A new release that goes through verification test is accomplished, documentation is updated, and a system validation test is defined. The validation test is then reviewed by the configuration control board and released for ground and flight test.

#### SIMULATION

Simulation is an integral part of the X-29A flight test program; the program would be severely constrained without the availability of a high-fidelity hardware-in-the-loop system. The simulation system (Figure 13) consists of two primary parts — standard Ames-Dryden equipment and X-29A specified equipment. The Ames-Dryden equipment includes various computer equipment that contains and processes the aerodynamic data package, a simulated cockpit, and display equipment. The X-29A specified equipment includes the flight control computers, the failure status control panel, actuator models, and other related equipment. The specified equipment also includes an XAIDS system that is a minicomputer-based device utilized to interrogate the flight control computers and software for systems testing and verification tests.

#### FLIGHT RESULTS OVERVIEW

The X-29A approach used to develop confidence in the FSW and related technologies is to validate the design, analyses, and test methods by correlating and comparing them with the flight research results. Careful analyses of the instrumentation requirements, flight test points, and maneuvers are conducted to ensure that data of sufficient quality and quantity are acquired to validate the design, fabrication, and test process (1).

The design flight envelope is shown in Figure 14. The shaded area represents the portion of the flight envelope that has been cleared. It is anticipated that the high-speed portion of the

envelope will be cleared by September 1986. The low-speed portion will be addressed in a follow-on high-angle-of-attack program starting in 1987.

Figures 15 to 20 present an overview of the key results obtained to date. Figure 15 illustrates lift coefficient as a function of drag coefficient and compares flight data with predicted data. The preliminary findings indicate that the drag data quality is  $\pm 50$  counts. There is a consistent magnitude and polar shape over the Mach range tested thus far. The flight drag data are lower than predicted for subsonic flight conditions. Also, there is a more favorable wing leading edge pressure profile above a lift coefficient equal to one than that predicted by the wind-tunnel data.

Figure 16 shows typical results for the pitch static stability parameter as a function of Mach number. Results to date indicate that the longitudinal stability is close to predictions. The lateral stability is slightly higher than predicted, and directional stability is lower than predicted. Typical flight control data are shown in Figure 17; low-frequency gain and phase margins are plotted as a function of Mach number. Initial results indicate that FCS performance (3) is excellent. There is very good correlation between flight and simulation, and the overall stability is equal to or better than predictions.

Typical results in the structural dynamics area are shown in Figure 18 in which structural damping and frequency are plotted as a function of equivalent velocity. No unexpected adverse trends in structural stability have been observed to date. Good correlation is found between predictions and flight measurements. No unexpected adverse trends in flutter and divergence have been observed, but the important transonic region has yet to be explored.

Buffet intensity rise, in the form of normal force coefficient and center-of-gravity normal acceleration as a function of Mach number, is shown in Figure 19. The buffet experienced is regarded as light to moderate. Canard buffet occurs prior to wing buffet and is greatly influenced by the deflection schedule. A light to moderate wing rock phenomenon was experienced for the low-speed, high-angle-of-attack flight conditions. Typical results obtained with the in-flight deflection measurement system are indicated in Figure 20. Wingbox twist data obtained from deflection measurements are plotted as a function of wing semispan. The initial flight deflection measurement data quality and quantity are very good. The Grumman lifting surface program predictions compare well.

#### SCHEDULE AND FUTURE PLANS

The goal for the X-29A program in 1986 is to complete the envelope expansion phase for aircraft one by September. After completion of envelope expansion, the current plan is to install a calibrated engine and wingtip shaker system on aircraft one and conduct additional

research in the aerodynamics, performance, and structures disciplines. Aircraft two is presently located at the Grumman facility in Bethpage, New York, where an instrumentation system and spin chute are being installed. The plan is to conduct a high-angle-of-attack research program, with flight test of aircraft two beginning in early 1987. The future technology requirements and research objectives for both aircraft are summarized in Table I.

#### CONCLUDING REMARKS

The X-29A flight research program is providing a unique and timely opportunity to close the loop on the aircraft analysis, design, fabrication, and ground and flight test process. The flight research program is providing the data necessary to improve the entire aircraft design, fabrication, and test process for future aircraft including the validation of design tools and the refinement of analytical methods. The advanced technologies incorporated in the X-29A program are integrated such that the total benefit is greater than the sum of the benefits of the individual technologies.

The initial flight research results are encouraging. There is good correlation of the aerodynamics, structures, and controls data with predictions. The aircraft flight systems are performing very well. The flight research program is well established and includes follow-on programs for two aircraft.

#### NOMENCLATURE

AFFTC      Air Force Flight Test Center  
ASD        Aeronautical Systems Division (U.S. Air Force)

DARPA      Defense Advanced Research Project Agency  
FCS        flight control system  
FRR        flight-readiness review  
FSW        forward-swept wing  
MOA        memorandum of agreement  
PCM        pulse code modulation  
SIBLINC    scale, invert, bias, logic, interface console

#### KEY WORDS

Data acquisition systems, flight  
Flight controls  
Flight test  
Forward-swept wing  
Instrumentation systems, flight

#### REFERENCES

- (1) Putnam, T.W., "X-29 Flight Research Program," NASA TM-86025, Jan. 1984.
- (2) Cutler, W., "X-29A Technology Demonstrator Program Status Review," 16th Annual SFTE Symposium, Sept. 1985, pp. 5.4-1 to 5.4-10.
- (3) Gera, J., "Dynamics and Controls Flight Testing of the X-29A Airplane," NASA TM-86803, Jan. 1986.

TABLE I. — FUTURE TECHNOLOGY REQUIREMENTS AND OBJECTIVES

Technology requirement	Research objective
X-29A aircraft one	
Advanced flight test techniques	Advanced performance and thrust modeling techniques Real-time analysis tools developed for flight controls
Wing-canard configurations	Determination of aerodynamic wing-canard interaction Boundary layer and pressure distribution correlations with predictions
FSW	Detailed aircraft drag and performance determination with calibrated engine Wing divergence determination
Aeroservoelasticity	Flight correlation with predicted structural stability Determination of aeroservoelastic stability margins
Flight controls and handling	Assessment of validity of current and new flying qualities criteria Control of highly unstable aircraft Three-surface control for trim and maneuverability
X-29A aircraft two	
Wing-canard configurations	Investigation of wing-canard aerodynamic interaction through flow visualization Evaluation of stall characteristics and wing rock tendencies
FSW	Measurement of instantaneous turning performance Assessment of tactical usefulness at high angles of attack
Three-surface control	Determination of control effectiveness for agility and controllability
Large negative stability margin	Evaluation of three-surface control characteristics at high angles of attack Development of flight test analysis tools Evaluation of FCS performance compared with present high-angle-of-attack criteria and predictive capabilities

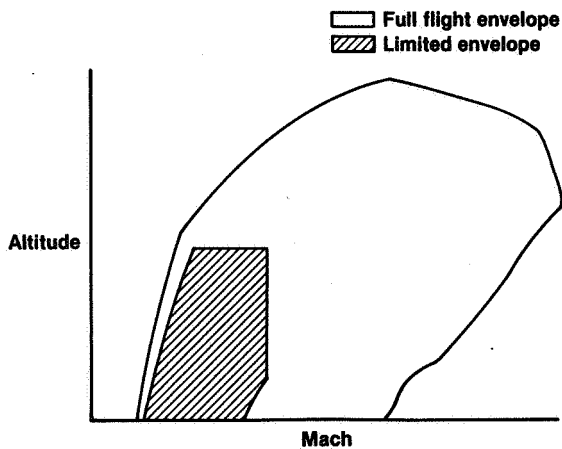

FIGURE 1. X-29A FLIGHT ENVELOPE FOR INITIAL AND PRESENT FLIGHT CONTROL SYSTEM

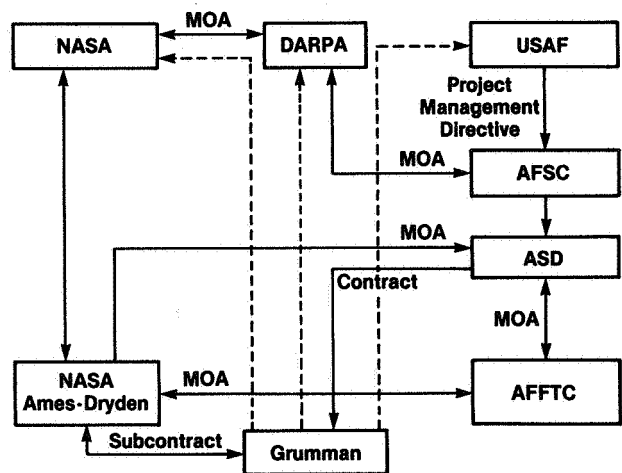
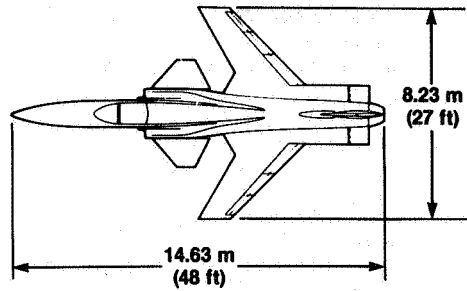

FIGURE 2. X-29A TEAM ORGANIZATIONAL STRUCTURE





- Height 4.27 m (14 ft)
- Wing area 17.2 m<sup>2</sup> (185 ft<sup>2</sup>)
- Aspect ratio 4.0
- Static thrust 7,257 kg (16,000 lb)
- Empty weight 5,897 kg (13,000 lb)
- Fuel capacity 1,814 kg (4,000 lb)

- F-5A forebody, cockpit, and inlet design
- F-18 F404-GE-400 engine
- F-16 main landing gear and actuators

FIGURE 3. X-29A KEY CHARACTERISTICS AND FEATURES

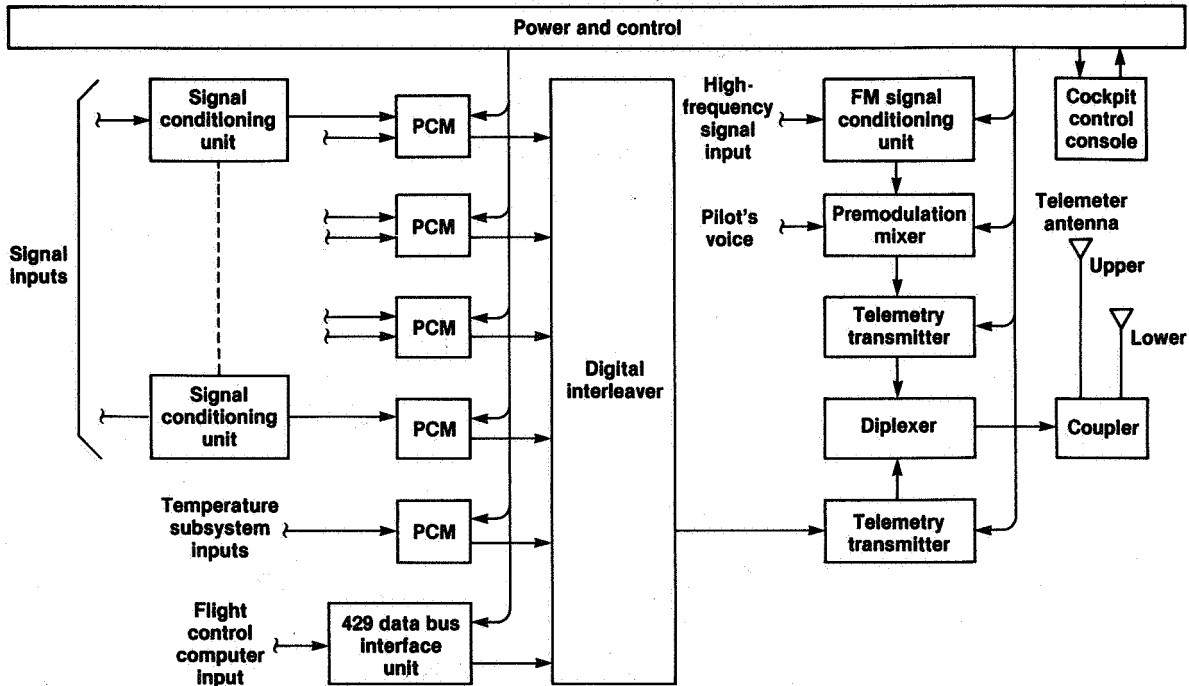

FIGURE 4. X-29A DATA ACQUISITION SYSTEM

- Basic parameters (53)**
  - Air data (9)
  - Angles of attack and sideslip (4)
  - Pitch, roll, yaw attitudes, rates, and accelerations (13)
  - Center-of-gravity accelerations (6)
  - Engine speed, temperature, and nozzle (10)
  - Surface positions (11)
- FCS (83)**
  - Computer parameters, 429 bus (76)
  - Stick position and forces (5)
  - Cockpit accelerations (2)
- Flutter and buffet (21)**
  - Accelerometers (21)
- Structures (118)**
  - Strain gages (106)
  - Optical deflection measurement system (12)
- Propulsion (21)**
  - Engine speed, temperatures, and geometry (21)
- Aerodynamic (173)**
  - Wing and strake static pressure (156)
  - Canard static pressures (17)
- Other systems (76)**
  - Hydraulic (6)
  - Environmental control (7)
  - Electrical (7)
  - Temperature (44)
  - Emergency power unit (10)
  - Aircraft-mounted accessory drive (2)

Total number of channels: 503

FIGURE 5. X-29A INSTRUMENTATION PARAMETERS

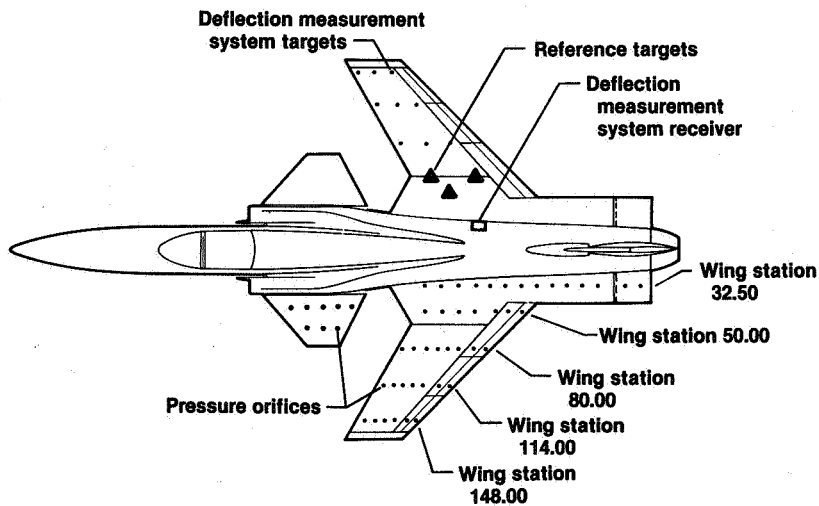

FIGURE 6. PRESSURE SURVEY INSTRUMENTATION AND OPTICAL DEFLECTION MEASUREMENT SYSTEM

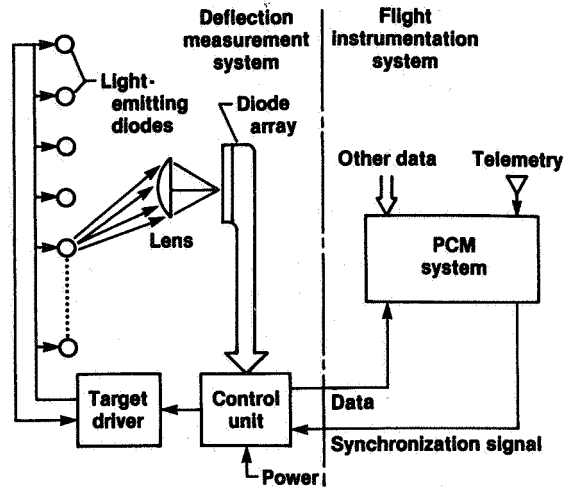

FIGURE 7. BLOCK DIAGRAM OF X-29A OPTICAL DEFLECTION MEASUREMENT SYSTEM

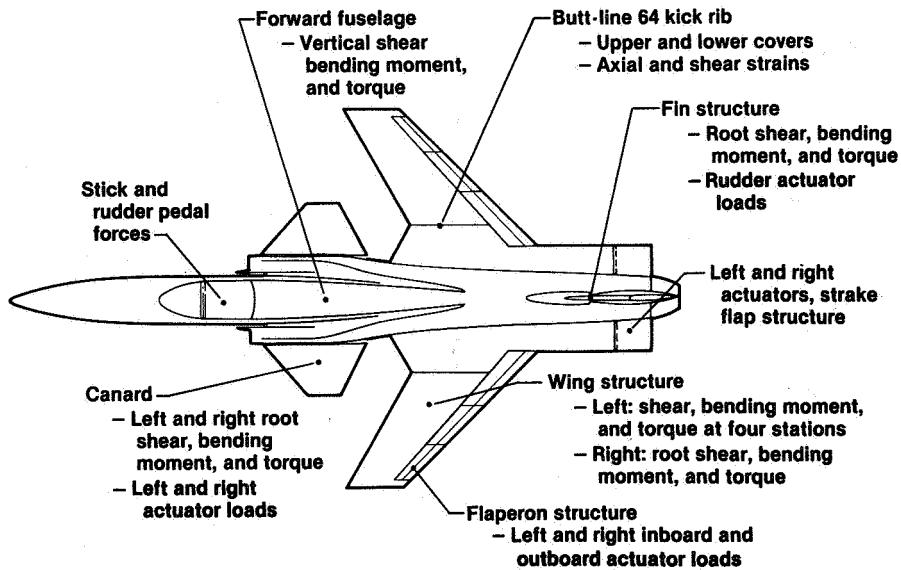

FIGURE 8. X-29A STATIC STRUCTURAL MEASUREMENT LOCATIONS

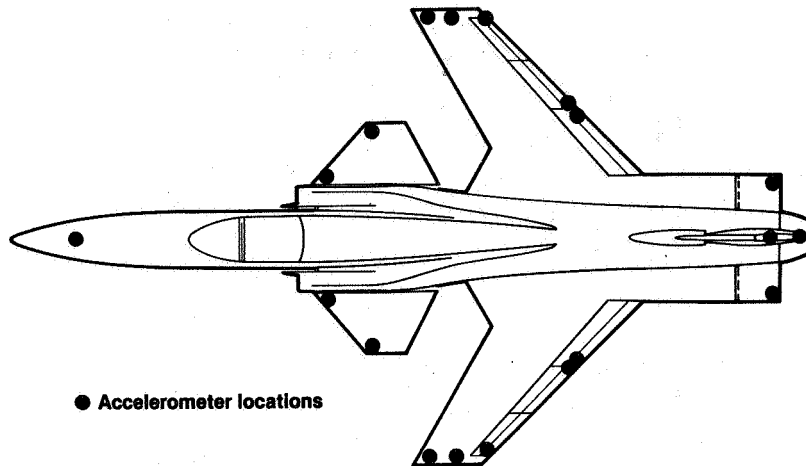

FIGURE 9. X-29A STRUCTURAL DYNAMICS AND BUFFET INSTRUMENTATION LOCATIONS

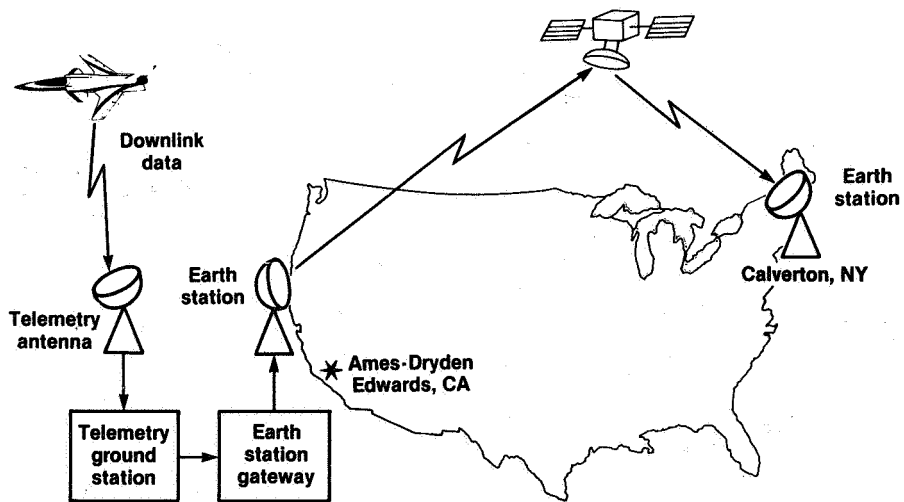

FIGURE 10. X-29A TRANSCONTINENTAL DATA LINK

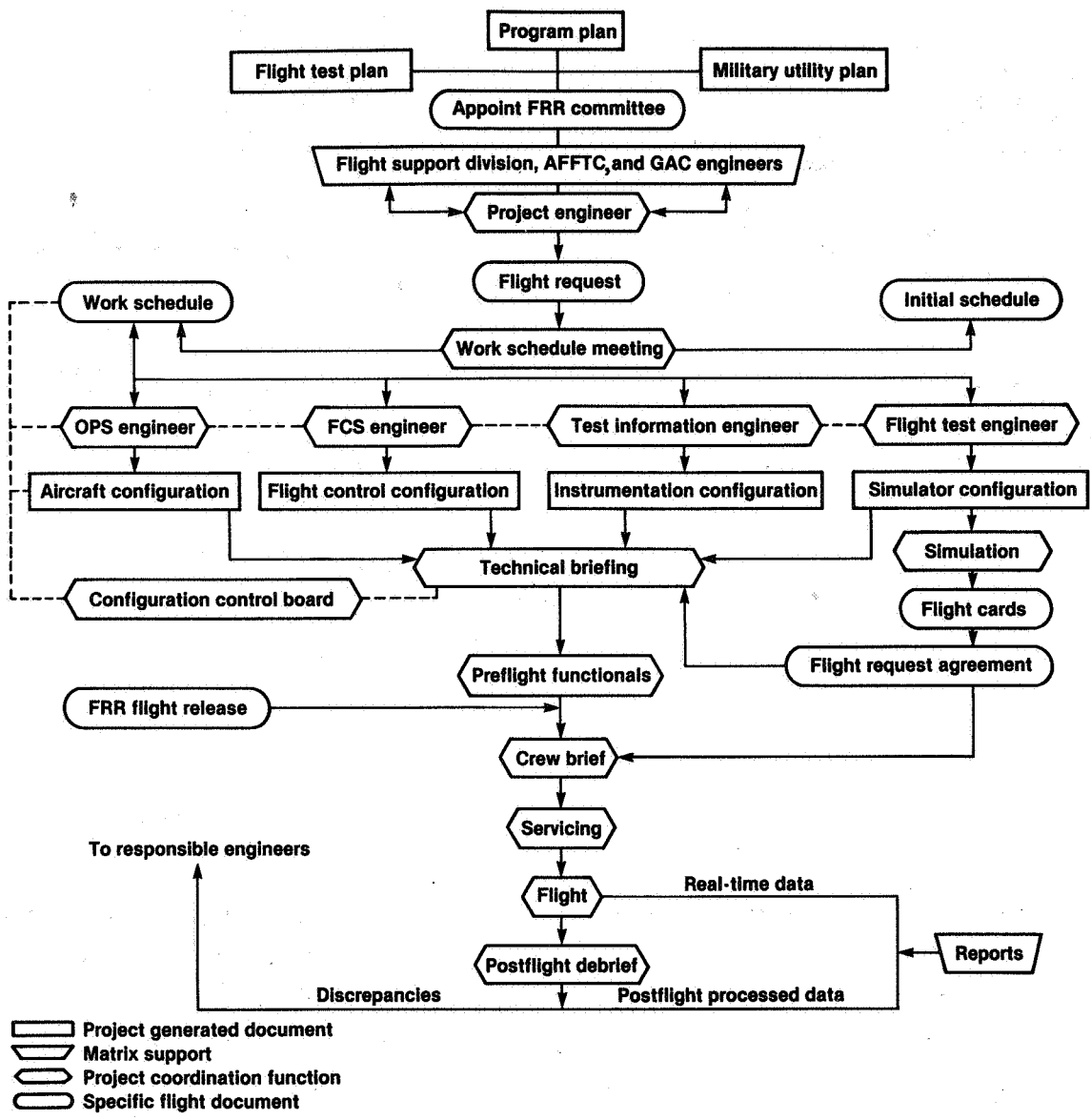

FIGURE 11. X-29A OPERATIONAL SEQUENCE

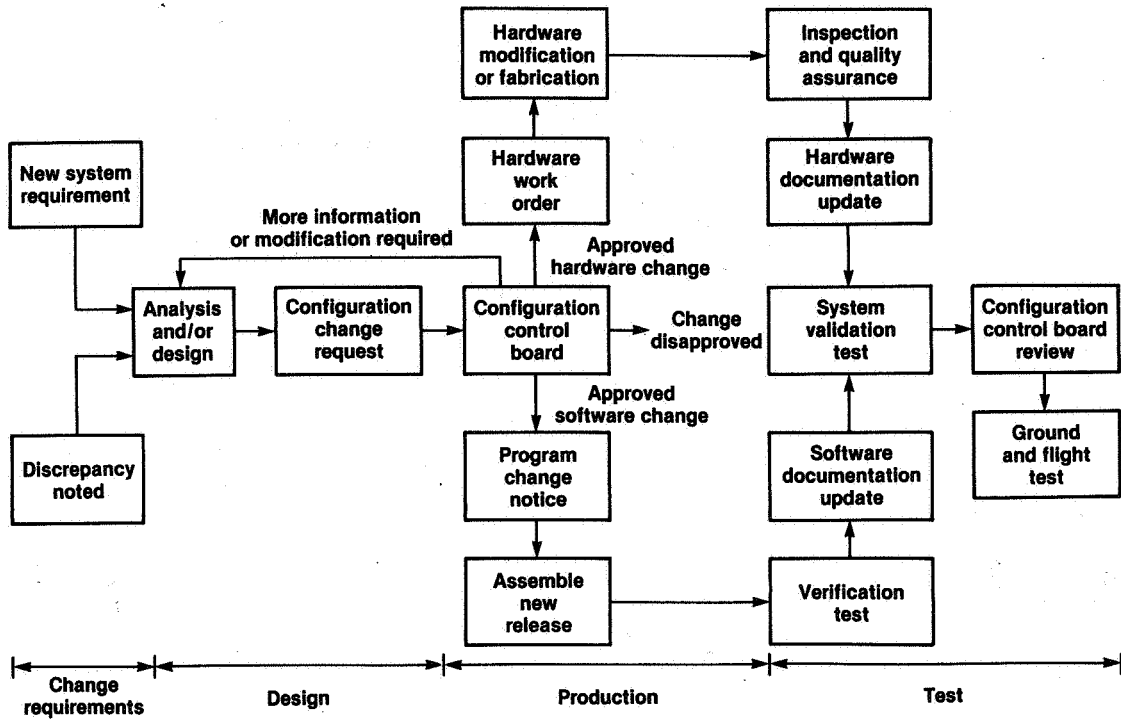

FIGURE 12. X-29A CONFIGURATION CONTROL PROCESS

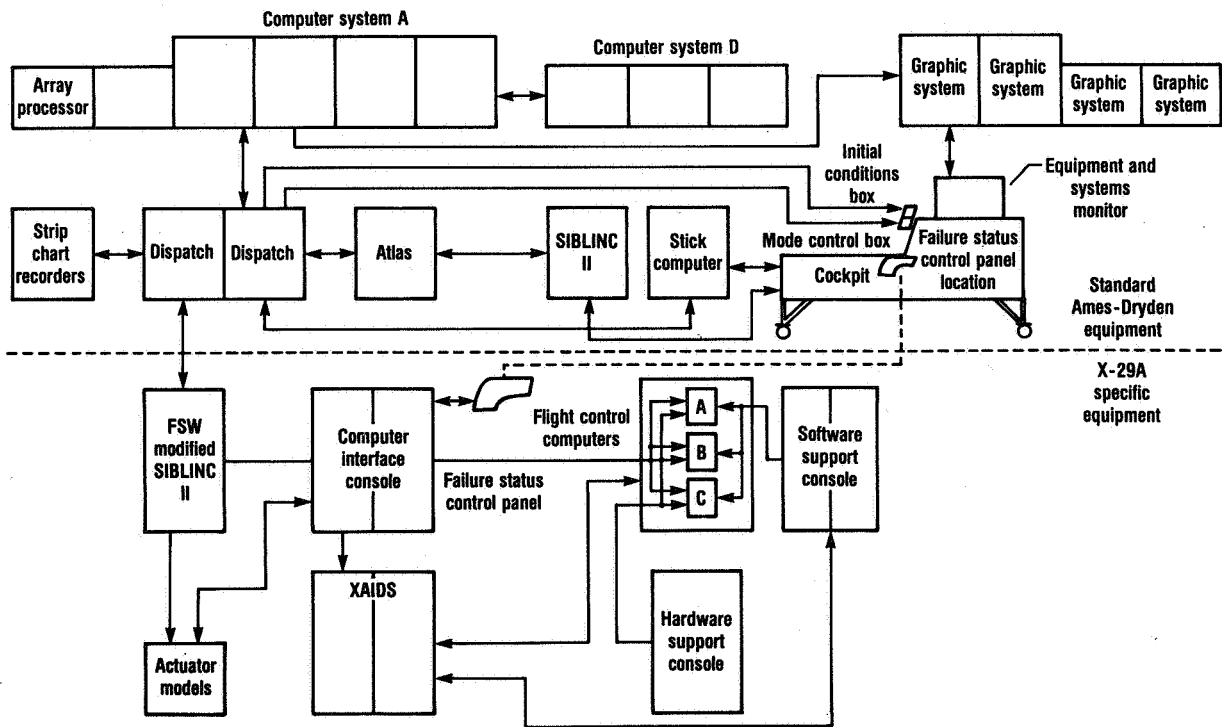

FIGURE 13. BLOCK DIAGRAM OF X-29A SIMULATION SYSTEM

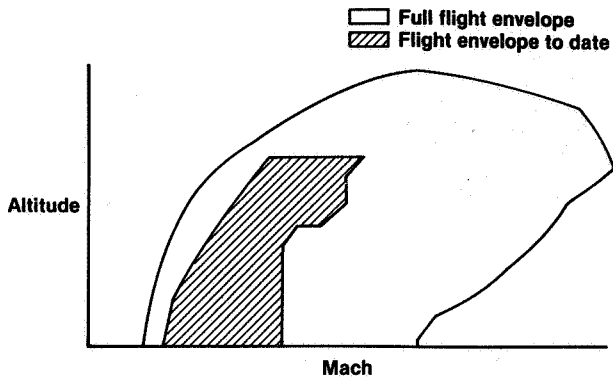

FIGURE 14. PRESENT X-29A EXPANDED FLIGHT ENVELOPE

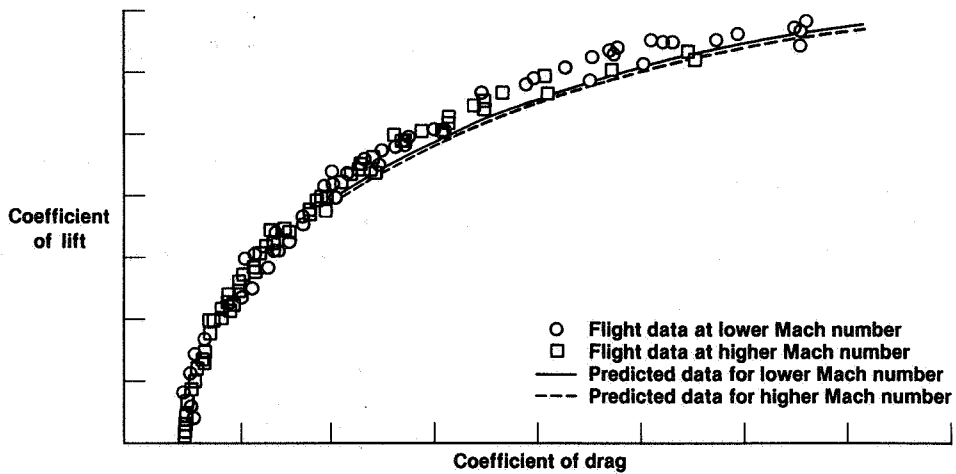

FIGURE 15. TYPICAL X-29A LIFT AND DRAG COEFFICIENT COMPARISON OF FLIGHT AND PREDICTED DATA

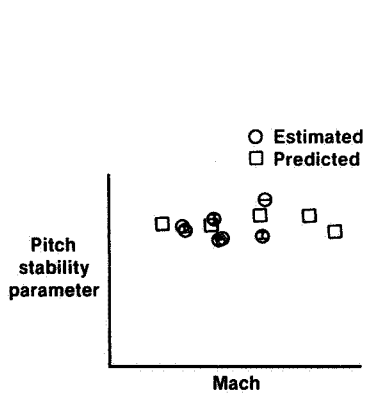

FIGURE 16. TYPICAL X-29A AERODYNAMIC COEFFICIENT ESTIMATED FROM FLIGHT DATA AND COMPARED WITH WIND TUNNEL PREDICTIONS

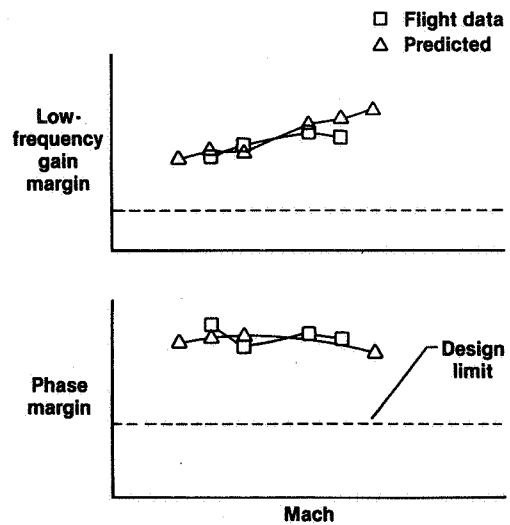

FIGURE 17. TYPICAL X-29A FLIGHT STABILITY MARGINS AS A FUNCTION OF MACH NUMBER COMPARED WITH WIND TUNNEL PREDICTIONS

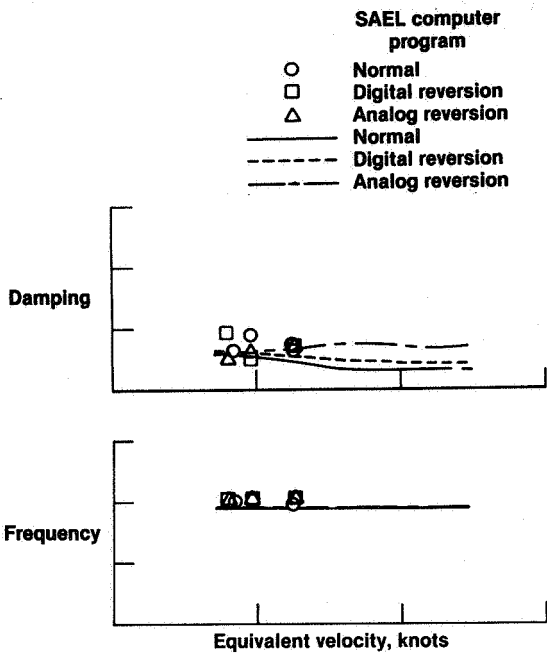

FIGURE 18. TYPICAL X-29A STRUCTURAL DYNAMICS DAMPING AND FREQUENCY COMPARED WITH COMPUTER ANALYSIS

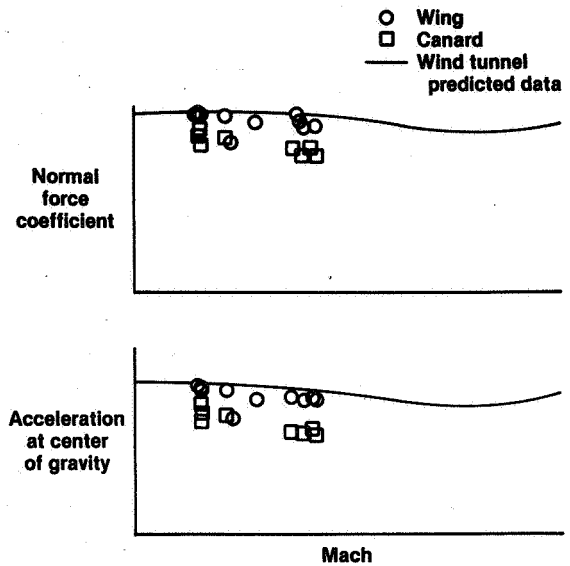

FIGURE 19. TYPICAL X-29A BUFFET INTENSITY BOUNDARY COMPARISONS OF FLIGHT AND WIND TUNNEL PREDICTED DATA

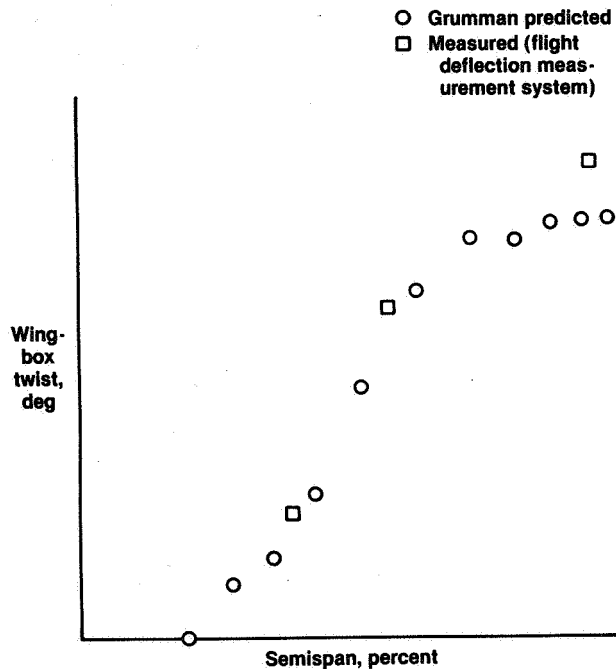

FIGURE 20. TYPICAL X-29A DEFLECTION MEASUREMENT DATA FOR WINGBOX TWIST AS A FUNCTION OF SEMISPAN COMPARED WITH PREDICTED DATA



1. Report No. NASA TM-86809	2. Government Accession No.	3. Recipient's Catalog No.	
4. Title and Subtitle X-29A TECHNOLOGY DEMONSTRATOR FLIGHT TEST PROGRAM OVERVIEW		5. Report Date May 1986	6. Performing Organization Code
		8. Performing Organization Report No. H-1347	
7. Author(s) Walter J. Sefic and Cleo M. Maxwell		10. Work Unit No. RTOP 533-02-51	11. Contract or Grant No.
9. Performing Organization Name and Address NASA Ames Research Center Dryden Flight Research Facility P.O. Box 273 Edwards, CA 93523-5000 <i>NC 499978</i>		13. Type of Report and Period Covered Technical Memorandum	
		14. Sponsoring Agency Code	
12. Sponsoring Agency Name and Address National Aeronautics and Space Administration Washington, D.C. 20546		15. Supplementary Notes Prepared as ISA Paper 504 for presentation at ISA Aerospace Industries/Test Measurement Symposium, Seattle, Washington, May 5-8, 1986.	
16. Abstract  <p>This paper presents an overview of the X-29A functional flight program and concept evaluation program, including some of the unique and different preparations for the first flight. Included are a discussion of the many organizational responsibilities and a description of the program management structure for the test team comprised of NASA, U.S. Air Force, and Grumman Corporation personnel. Also discussed are preflight ground, flight functional, envelope expansion, and flight research test objectives and qualitative results to date for both a limited-envelope flight control system and an expanded-envelope system.</p> <p>A brief description of the aircraft, including the instrumentation system and measurements, is also presented. In addition, a discussion is included regarding the use of major support facilities, such as ground and flight simulators, the NASA Western Aeronautical Test Range and mission control center, and the Grumman automated telemetry station linked to the test site by means of a satellite data link. An overview of the associated real-time and postflight batch data processing software approaches is presented. The use of hardware-in-the-loop simulation for independent verification and validation and mission planning and practice is discussed.</p> <p>A discussion is included regarding the approach to flight operations for the X-29A that was used by the Dryden Flight Research Facility of NASA Ames Research Center. Also included is a description of the flight-readiness review, the airworthiness and flight safety review, work scheduling, technical briefings, and preflight and postflight crew briefings. The configuration control process used on the X-29A program is described, and its relationship to both simulation and aircraft operations is discussed. An X-29A schedule overview is presented with an outline of a proposed follow-on program.</p>			
17. Key Words (Suggested by Author(s)) Data acquisition systems, flight Flight controls Flight test Forward-swept wing Instrumentation systems, flight		18. Distribution Statement Unclassified - Unlimited  STAR category 05	
19. Security Classif. (of this report) Unclassified	20. Security Classif. (of this page) Unclassified	21. No. of Pages 15	22. Price* A02

*\*For sale by the National Technical Information Service, Springfield, Virginia 22161.*