

NASA CR-175,084

NASA CR175084

RI/RD86-116

NASA-CR-175084
19860016897



INTERIM REPORT

ORBIT TRANSFER ROCKET ENGINE TECHNOLOGY PROGRAM

ADVANCED ENGINE STUDY
TASK D.1/D.3

Prepared By:

A. Martinez, C. Erickson, B. Hines
ROCKWELL INTERNATIONAL CORPORATION
Rocketdyne Division

Prepared For:

NATIONAL AERONAUTICS AND SPACE ADMINISTRATION

January 1986

NASA-Lewis Research Center

Contract NAS3-23773

L. P. Cooper, Project Manager

LIBRARY COPY

Jan 21 1986

LANGLEY RESEARCH CENTER
LIBRARY, NASA
HAMPTON, VIRGINIA

ROCKETDYNE DIVISION OF ROCKWELL INTERNATIONAL CORPORATION
6633 Canoga Avenue; Canoga Park, CA 91303



NF01244

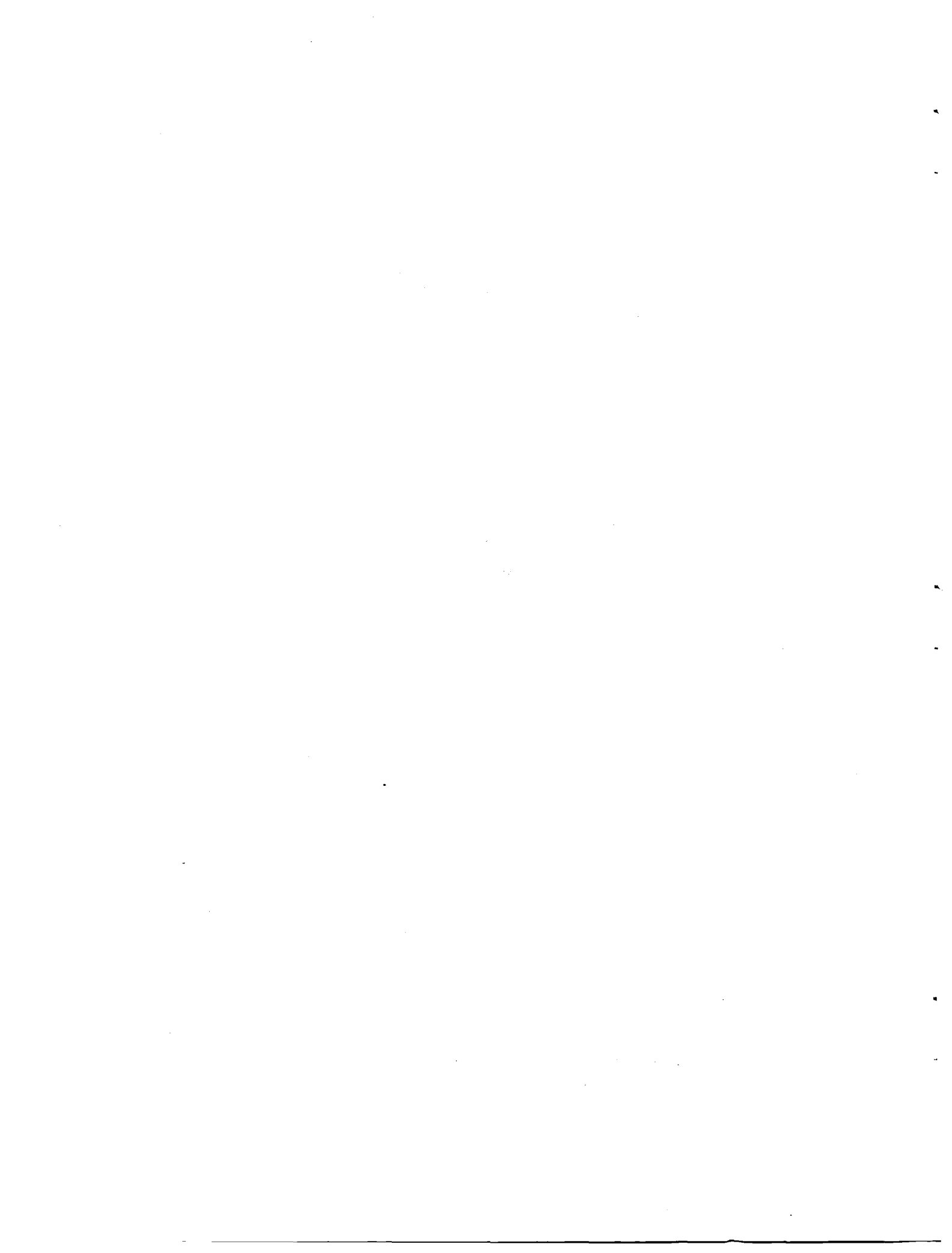

1. Report No. NASA	2. Government Accession No.	3. Recipient's Catalog No.	
4. Title and Subtitle ORBIT TRANSFER ROCKET ENGINE TECHNOLOGY PROGRAM - INTERIM REPORT, ADVANCED ENGINE STUDY		5. Report Date JANUARY 1986	6. Performing Organization Code
		8. Performing Organization Report No. RI/RD86-116	
7. Author(s) A. MARTINEZ, C. ERICKSON, B. HINES		10. Work Unit No. RTPO 506-42-21, TASK YOS2582	11. Contract or Grant No. NAS3-23773
9. Performing Organization Name and Address ROCKETDYNE DIVISION, ROCKWELL INTERNATIONAL 6633 Canoga Avenue Canoga Park, California 91304		13. Type of Report and Period Covered Interim Report	
		14. Sponsoring Agency Code	
12. Sponsoring Agency Name and Address NASA-Lewis Research Center, Communications and Propulsion Section, 21000 Brookpark Road MS 500-306, Cleveland, Ohio 44135		15. Supplementary Notes Project Manager, L. P. Cooper, NASA-Lewis Research Center, Cleveland, Ohio MSFC Coordinator, S. McIntyre, NASA-Marshall Space Flight Center, Huntsville, Alabama	
16. Abstract In this study concepts for space maintainability of OTV engines were examined. The advanced technology efforts were conducted under the Advanced Engine Study Task of the Orbit Transfer Rocket Engine Technology Program. An engine design was developed which was driven by space maintenance requirements and by a Failure Modes and Effects (FME) analysis. Modularity within the engine was shown to offer cost benefits and improved space maintenance capabilities. Space-operable disconnects were conceptualized for both engine change-out and for module replacement. Through FME mitigation the modules were conceptualized to contain the least reliable and most often replaced engine components. A preliminary space maintenance plan was developed around a Controls and Condition Monitoring system using advanced sensors, controls, and condition monitoring concepts. A complete engine layout was prepared satisfying current vehicle requirements and utilizing projected component advanced technologies. A technology plan for developing the required technology was assembled.			
17. Key Words (Suggested by Author(s)) Hydrogen/Oxygen Engine Hydrogen/Oxygen Technology High Pressure Pumps/Combustion High Area Ratio Nozzles Expander Cycle Engine		18. Distribution Statement	
19. Security Classif. (of this report) Unclassified	20. Security Classif. (of this page) Unclassified	21. No. of Pages	22. Price*

* For sale by the National Technical Information Service, Springfield, Virginia 22151

CONTENTS

	<u>PAGE</u>
INTRODUCTION	1
OBJECTIVES.....	1
APPROACH.....	1
SUMMARY OF ACCOMPLISHMENTS.....	4
TECHNICAL DISCUSSION.....	8
INTRODUCTION.....	8
IDENTIFICATION OF VEHICLE-DERIVED-REQUIREMENTS.....	10
BASELINE ENGINE DEFINITION.....	15
ADVANCED COMPONENT TECHNOLOGIES.....	15
ENGINE PERFORMANCE OPTIMIZATION.....	17
ENGINE THRUST STUDY.....	24
CONTROL SYSTEM ASSESSMENT.....	24
THROTTLING AND STABILITY.....	35
FAILURE MODE EFFECTS AND RELIABILITY ANALYSES REVIEW.....	39
FMEA AND RELIABILITY ANALYSES.....	39
FME MITIGATION AND RELIABILITY IMPROVEMENT.....	43
APPROACH.....	43
COMPONENT DESIGN EVALUATION.....	45
ENGINE AND CYCLE DESIGN EVALUATION.....	48
THRUST AND MR CONTROL DURING TRANSIENT.....	54
REDUNDANCY.....	59
ICHM EVOLUTION.....	64
SERVICING.....	71

CONTENTS
(continued)

	<u>PAGE</u>
MAINTAINABILITY STUDIES & PLAN.....	72
REQUIREMENTS.....	83
ICHM SYSTEM REVIEW.....	91
VEHICLE/SYSTEM INTEGRATION.....	92
COUPLING OPERATION.....	108
PERFORMANCE DURING ENGINE OPERATION.....	110
FABRICATION/DEVELOPMENT/MAINTENANCE.....	112
ENGINE AND COMPONENT DESIGN.....	118
ADVANCED ENGINE CONCEPTS.....	132
ENGINE DESIGN UPDATE.....	140
TECHNOLOGY PLANS.....	145
TASK NO. 1 TURBINE SHUTOFF VALVE (TSV).....	146
TASK NO. 2 CONSOLIDATED TSV AND TBV.....	148
TASK NO. 3 CONSOLIDATED MOV AND GOV.....	150
TASK NO. 4 ELECTRIC ACTUATED CARTRIDGE VALVES.....	152
TASK NO. 5 MODULAR IGNITER.....	154
TASK NO. 6 COMPOSITE MATERIALS.....	156
TASK NO. 7 NOZZLE RETRACTION DEVICES.....	158
TASK NO. 8 NOZZLE FLUID INTERCONNECTS.....	160
TASK NO. 9 NOZZLE SEGMENT INTERFACE SEALS.....	162
TASK NO. 10 SPACE OPERABLE FLUID DISCONNECTS.....	164

TABLES

<u>No.</u>		<u>Page</u>
1	ADVANCED ENGINE STUDIES.....	2
2	OTV ROCKET ENGINE TECHNOLOGY TASKS, NAS3-23773.....	3
3	PHASE I - FMEA-MAINTENANCE DRIVEN DESIGN ACCOMPLISHMENTS.....	6
4	ENGINE DESIGN DRIVEN MISSIONS.....	11
5	ENGINE REQUIREMENTS, 1990'S OTV (PRIORITIZED).....	12
6	ENGINE CHARACTERISTICS - 1990'S OTV.....	14
7	RESULTS SUMMARY OF ENGINE OPTIMIZED RUNS FOR ADVANCED.....	19
	TECHNOLOGY ENGINE AT 7500 LB THRUST	
8	TURBOMACHINERY TIP SPEED AND STRESS LIMITS.....	20
9	BASELINE ENGINE DESCRIPTION.....	25
10	ENGINE CONTROLS SYSTEM CONCEPTS DEFINITION.....	26
11	EXPANDER CYCLE PERFORMANCE.....	29
12	ACTUATOR REQUIREMENTS.....	30
13	EXPANDER CYCLE ENGINE START AND SHUTDOWN REQUIREMENTS.....	32
14	VALVE SUMMARY.....	35
15	OTV 7.5K ENGINE OFF-DESIGN SUMMARY.....	36
16	7.5K LBENGINE BALANCE SUMMARY AT OFF-DESIGN.....	38
	THRUSTS AND MIXTURE RATIOS	
17	OIV ENGINE CRITICALITY SUMMARY.....	42
18	FMEA MITIGATION AND RELIABILITY IMPROVEMENT.....	44
19	FAILURE MITIGATION THROUGH ENGINE AND ICHM DESIGN.....	46
20	FAILURE MODE MITIGATION AND RELIABILITY IMPROVEMENT.....	47
	VALVE ACTUATOR DESIGN	
21	IMPROVING TURBOMACHINERY RELIABILITY.....	49
22	OFF-DESIGN LIFETIME IMPACTS ON OTV ENGINES.....	52

TABLES
(continued)

<u>No.</u>		<u>Page</u>
23	COMPARISON OF 7.5K AND DERATED 15K ENGINES.....	53
24	MODULAR ENGINE DESIGN-FM BREAKDOWNS.....	55
25	7.5K ENGINE STARTS AND SHUTDOWN TIME CAPABILITIES.....	58
26	OTV ENGINE RELIABILITY DATA.....	63
27	FUNCTION REDUNDANCY-ENGINE AND TURBOMACHINERY..... (MEAN TIME TO FAILURE AND RELIABILITY)	65
28	ADVANCED ICHM SENSORS.....	69
29	COSI COMPARISON OF R&R MAINTENANCE OPTIONS.....	79
30	GROUND VS. SPACE R&R MAINTENANCE TIME AND COST.....	82
31	CONTROL AND HEALTH MONITORING INSTRUMENTATION.....	84
32	ENGINE COMPONENTS LIFE, 15K LB NEAR-TERM ENGINE.....	87
33	ADVANCED INTERFACES ENABLE SPACE MAINTENANCE.....	93
34	MODULAR ENGINE INTERFACE LOCATIONS & ENVIRONMENTS.....	107
35	ADVANCED INTERFACE COUPLING SELECTION.....	109
36	INTERFACE COUPLING EVALUATION -1.....	114
37	INTERFACE COUPLING EVALUATION -2.....	115
38	INTERFACE COUPLING EVALUATION -3.....	116
39	ENGINE MODULARITY OPTIONS.....	125
40	ADVANCED OTV ENGINE WEIGHTS.....	128
41	WEIGHT EFFECTS OF SPACE MAINTAINABILITY INTERFACES.....	131
42	INNOVATIVE CONCEPTS LIST.....	133
43	IGNITER COMPARISON.....	144

FIGURES

<u>No.</u>		<u>Page</u>
1	ADVANCED ENGINE STUDY SCHEDULE.....	7
2	PHAE I STUDY LOGIC DIAGRAM.....	9
3	BASELINE OTV ENGINE.....	16
4	7.5K ENGINE COMPONENT TECHNOLOGIES.....	18
5	SERIES TURBINE BASELINE OTV ENGINE SCHEMATIC -	28
	MAIN PROPELLANT CONTROL VALVES	
6	DUAL-DUAL REDUNDANT CROSS-STRAPPED SYSTEMS.....	33
7	PREDICTED FUEL PUMP PERFORMANCE FOR 7500 LB ENGINE.....	37
8	FAILURE MODE EFFECTS AND RELIABILITY ANALYSIS REVIEW.....	40
	AND APPLICATION	
9	OFF-DESIGN LIFETIME TRENDS THRUST CHAMBER.....	50
10	MODULAR ENGINE, TOP VIEW.....	56
11	OTV 7.5K ENGINE FLOW SCHEMATIC WITH TURBINE.....	60
	SHUTOFF VALVE	
12	REDUNDANT TURBOPUMP FUNCTIONS.....	62
13	REDUNDANCY, MISSION COST IMPACT.....	66
14	MODULAR OTV ENGINE WITH ADVANCED INSTRUMENTATION.....	70
	SCHEMATIC	
15	OTV ENGINE FUEL TURBOPUMP.....	75
	REMOVAL/INSTALLATION/CHECKOUT TIMELINE	
16	OTV ENGINE FUEL MODULE.....	76
	REMOVAL/INSTALLATION/CHECKOUT TIMELINE	
17	OTV ENGINE ASSEMBLY.....	77
	REMOVAL/INSTALLATION/CHECKOUT TIMELINE	

FIGURES
(continued)

<u>No.</u>		<u>Page</u>
18	OTV ENGINE FUEL TURBOPUMP.....	80
	REMOVAL/INSTALLATION/CHECKOUT TIMELINE (ON GROUND)	
19	MAINTENANCE PLAN OUTLINE.....	85
20	ICHM FUNCTION ALLOCATION AND LOGIC DIAGRAM.....	90
21	SELF-RETAINED, REDUNDANT SEALING FACE SEAL CONCEPT.....	95
22	CAPTIVE-BOLT DISCONNECT JOINT.....	96
23	CARRIAGE/HOOK COUPLING CONCEPT.....	98
24	SPRING-COLLAR INTERFACE COUPLING CONCEPT.....	99
25	SPRING-COLLAR COUPLING INSTALLATION TOOL.....	101
26	SEGMENTED-THREAT COUPLING CONCEPT.....	102
27	CONOSEAL V-BAND COUPLING.....	104
28	GAMAH EDGE SEAL.....	104
29	DYNATUBE COUPLING.....	106
30	PARKER LO-TORQUE COUPLING.....	106
31	OTV 4-STAGE HPFTP.....	119
32	MK 49-0 HPOTP.....	120
33	THRUST CHAMBER ASSEMBLY.....	122
34	FLIGHTWEIGHT ELECTRIC ACTUATED VALVE.....	123
35	MODULAR OTV ENGINE-SCHEMATIC.....	124
36	7.5K ADVANCED SPACE-BASED OTV ENGINE ARRANGEMENT -AP84.....	127
37	7.5K ADVANCED SPACE-BASED OTV ENGINE ARRANGEMENT -7R03.....	141
38	MODULAR IGNITER CONCEPT.....	143

FOREWORD

The work reported herein was conducted by the Advanced Programs and Engineering personnel of Rocketdyne, a Division of Rockwell International Corporation, under Contract NAS3-23773 from June 1984 to January 1986. Dr. L. P. Cooper, Lewis Research Center, was the NASA Project Manager. Mr. A. T. Zachary was the Rocketdyne Program Manager, and Mr. A. Martinez, as Study Manager was responsible for the technical direction of the program.

Important contributions to the conduct of the program, and to the preparation of the material, were made by the following Rocketdyne personnel:

Engine System Analysis	D. Nguyen, C. Erickson
Engine System Design	B. Hines
Failure Modes and Effects Analysis	T. Hull
Consolidated Valve Design	G. Tellier

INTRODUCTION

The Advanced Engine Study (Task D.1) has been outlined as a four year effort in which the engine design will be iterated four times to allow resolution of vehicle/engine integration issues as well as advanced engine performance, operation and maintenance technology issues. When completed the conceptual engine system design description will include all the engine subsystems. Design iteration of the ICHM subsystem will be performed in Task E.2 - Integrated Control and Health Monitoring System. Each successive iteration will provide as output an updated engine system design, and the advanced technology and plans required for expeditious development of the space-baseable and maintainable engine. The complete four year effort is described in Task Work Plan Document RI/RD84-122.

OBJECTIVES

Objectives, and status of the Advanced Engine Study are indicated in Table 1. The overall objective is to develop a space-baseable engine design and to define and update its advanced technology and technology development plans.

APPROACH

The approach to performance of the objectives is to develop the engine design and technology plan in four study phases as outlined in Table 1.

Each phase will be driven respectively by the timing and results of four main occurrences: (1) the completion of advanced engine FMEA (Failure Mode and Effects Analysis) and maintenance studies; (2) the completion of Orbit Transfer Vehicle (OTV) definition and Aeroassist OTV studies; (3) the completion of near-term advanced technology evaluation studies of NAS3-23773 Contract Tasks B.1, C.1, B.2, and F.2; and (4) the completion of longer-range advanced technology studies of NAS3-23773 contract Tasks E.1, E.2, B.3, and A.8 (Table 2).

TABLE 1.

ADVANCED ENGINE STUDIES

OBJECTIVES:

- PROVIDE A SPACE BASABLE/MAINTAINABLE ENGINE DESIGN
- IDENTIFY ADVANCED TECHNOLOGY REQUIRED
- PREPARE TECHNOLOGY AND ENGINE DEVELOPMENT PLANS
- UPDATE ENGINE DESIGN AND TECHNOLOGY THROUGH 1990

APPROACH:

- DEVELOP ENGINE DESIGN IN FOUR PHASES
 - PHASE I FMEA – MAINTENANCE DRIVEN DESIGN
 - PHASE II THRUST LEVEL ENGINE DESIGN UPDATE
 - PHASE III PERFORMANCE, LIFE, OPERATIONS DESIGN UPDATE
 - PHASE IV FINAL ICHM/MAINTENANCE/FMEA UPDATE

STATUS:

- PHASE I – COMPLETED
- PHASE II – FUNDING PENDING

TABLE 2. OTV ROCKET ENGINE TECHNOLOGY TASKS, NAS3-23773

- Task B.1 - Two-Stage Partial Admission Turbine**
- Task C.1 - Enhanced Heat Load Thrust Chamber**
- Task E.1/E.2 - Integrated Control and Health Monitoring System**
- Task F.2 - Integrated Components Evaluator**
- Task B.2 - High Velocity Diffusing Crossover**
- Task B.3 - Soft-Wear Ring Seals**
- Task A.8 - Hydrogen Regenerator**

SUMMARY OF ACCOMPLISHMENTS

After an in-depth review of vehicle derived requirements provided by the four vehicle contractors, a 7500 lb thrust baseline engine was selected. Engine operation studies were conducted to define and optimize engine design parameters for this baseline engine. This was followed by a review of the FEMA and reliability analyses which were conducted under the ICHM Task E.1. In this review, the impact of the FMEA on engine design was assessed and methods for FME mitigation and reliability improvements through component design evolution, engine and cycle design evolution, redundancy schemes, and ICHM evolution were generated. Concurrently, an initial space-based maintenance philosophy was established and requirements for its implementation were determined. This maintenance philosophy centers on the benefits of a modular engine concept and the use of advanced sensors for health monitoring. In this approach, engine servicing will be done on an as-needed basis determined by the health monitoring systems as opposed to a more frequent scheduled routine. In addition, health monitoring would obviate costly routine inspections required to assess components status. When servicing is required, the modular engine design permits quick and easy removal and replacement of component groups. Space-based servicing such as this requires advanced fluid disconnects easily operable by an EVA astronaut or robotic manipulator. Several preliminary design concepts for space operable fluid disconnects were generated during this study. These concepts were evaluated and ranked based on coupling operatin, performance, fabrication, development, and maintenance.

As part of the advanced concept evolution, a comprehensive list of innovative ideas was identified and evaluated by the respective components specialists. Many of these concepts were offshoots of the FMEA review and maintainability studies and thus are integral parts of the space-based maintenance philosophy. Technology plans were generated for several of the concepts which were deemed as worthy of further investigation with fruition expected within the time frames of interest.

Efforts of this study culminated in the generation of an updated maintenance driven engine design. Salient features of this design include space operable vehicle interface couplings, advanced sensors for health monitoring, and a dual igniter module. Disconnects permitting modular maintenance were not included since the current preference of the vehicle contractor for servicing is engine only replacement. However, the packaging and line arrangement is configured such that modular servicing could be realized with the simple addition of couplings.

A summary of the Phase I - FMEA-Maintenance driven design accomplishments is presented in Table 3. In addition, a program schedule highlighting the milestones completed is shown in more detail in Figure 1.

Additional effort will be required in Phase 2 for evaluation of several of the innovative concepts which were not addressed in this study. Development of the maintenance plan will be an on-going effort and is expected to progress in parallel with the evolution of the space-based engine in the subsequent phases of the study.

TABLE 3.
PHASE I - FMEA-MAINTENANCE DRIVEN DESIGN ACCOMPLISHMENTS

- **SELECTED 7500 LB BASELINE ENGINE**
- **DETERMINED IMPACT OF FMEA ON ENGINE DESIGN**
- **ESTABLISHED INITIAL SPACE BASED MAINTENANCE PHILOSOPHY AND REQUIREMENTS**
- **DETERMINED IMPACT OF FMEA/MAINTENANCE ON ENGINE PACKAGING**
- **IDENTIFIED AND EVALUATED INNOVATIVE CONCEPTS**
- **GENERATED TECHNOLOGY PLANS REQUIRED FOR ADVANCED ENGINE EVOLUTION**
- **GENERATED PRELIMINARY DESIGN FOR SPACE OPERABLE FLUID DISCONNECTS**
- **GENERATED UPDATED MAINTENANCE DRIVEN ENGINE DESIGN INCORPORATING INNOVATIVE CONCEPTS**

ADVANCED ENGINE STUDY SCHEDULE

RI/RD86-116
7

86C-9-12

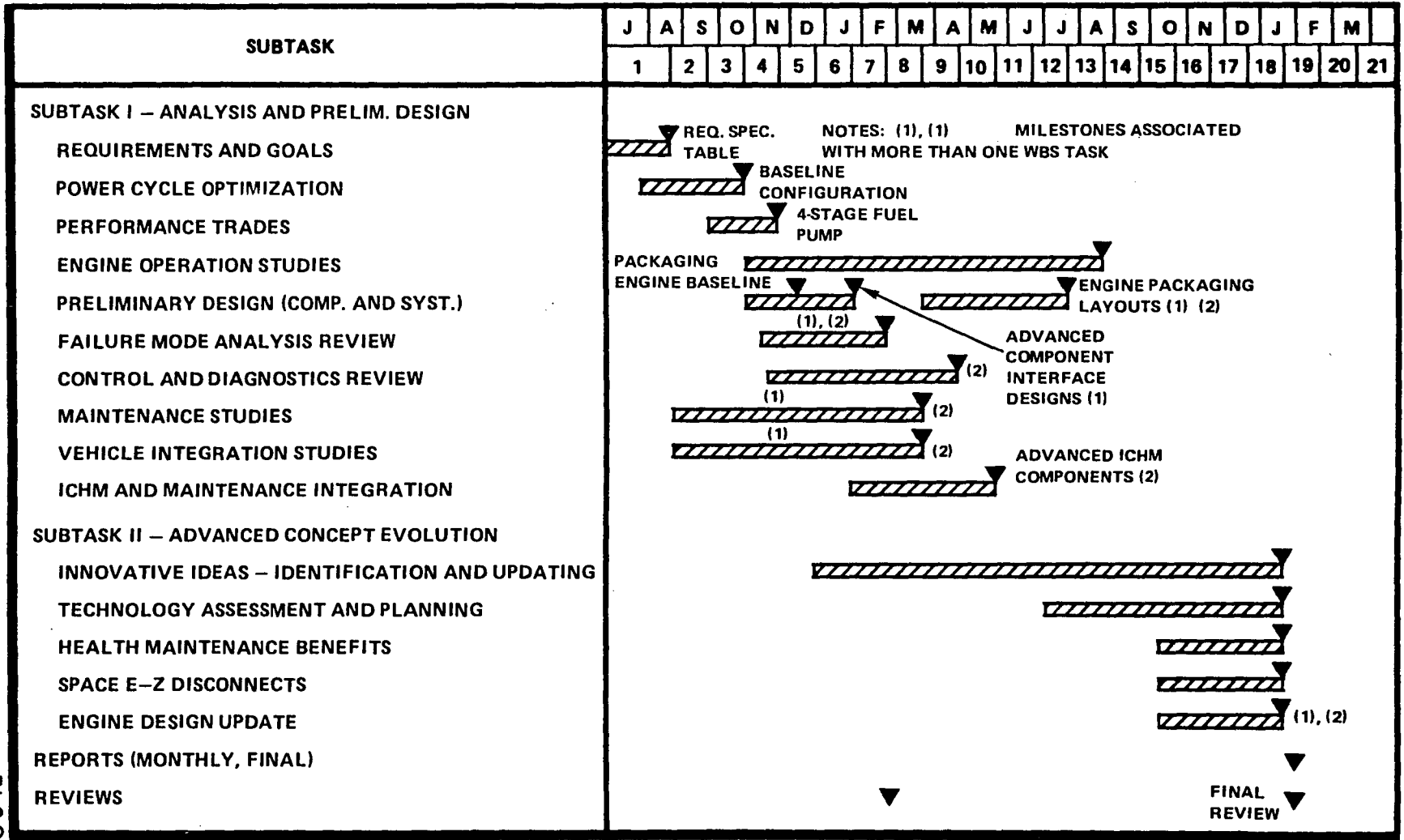

FIGURE 1.

TECHNICAL DISCUSSION

INTRODUCTION

The overall approach followed in Phase I of the advanced engine study is presented in Figure 2. Engine requirements were first established based on information available from the vehicle contractors working on the OTV studies. Through trade studies and optimizations, a baseline engine concept was derived. This engine concept was then subjected to a series of studies and reviews as depicted in the third block of the Phase I study logic diagram. Primary effort in this area was directed toward the maintainability studies/plan, the FMEA/reliability review, and the engine and component design. Results of these studies were then used in the formulation of advanced engine concepts to be integrated into the baseline engine. In this manner, an updated maintenance driven engine design was generated. Technology development plans including brief statements of work and development schedules were written for the advanced engine concepts.

PHASE I STUDY LOGIC DIAGRAM

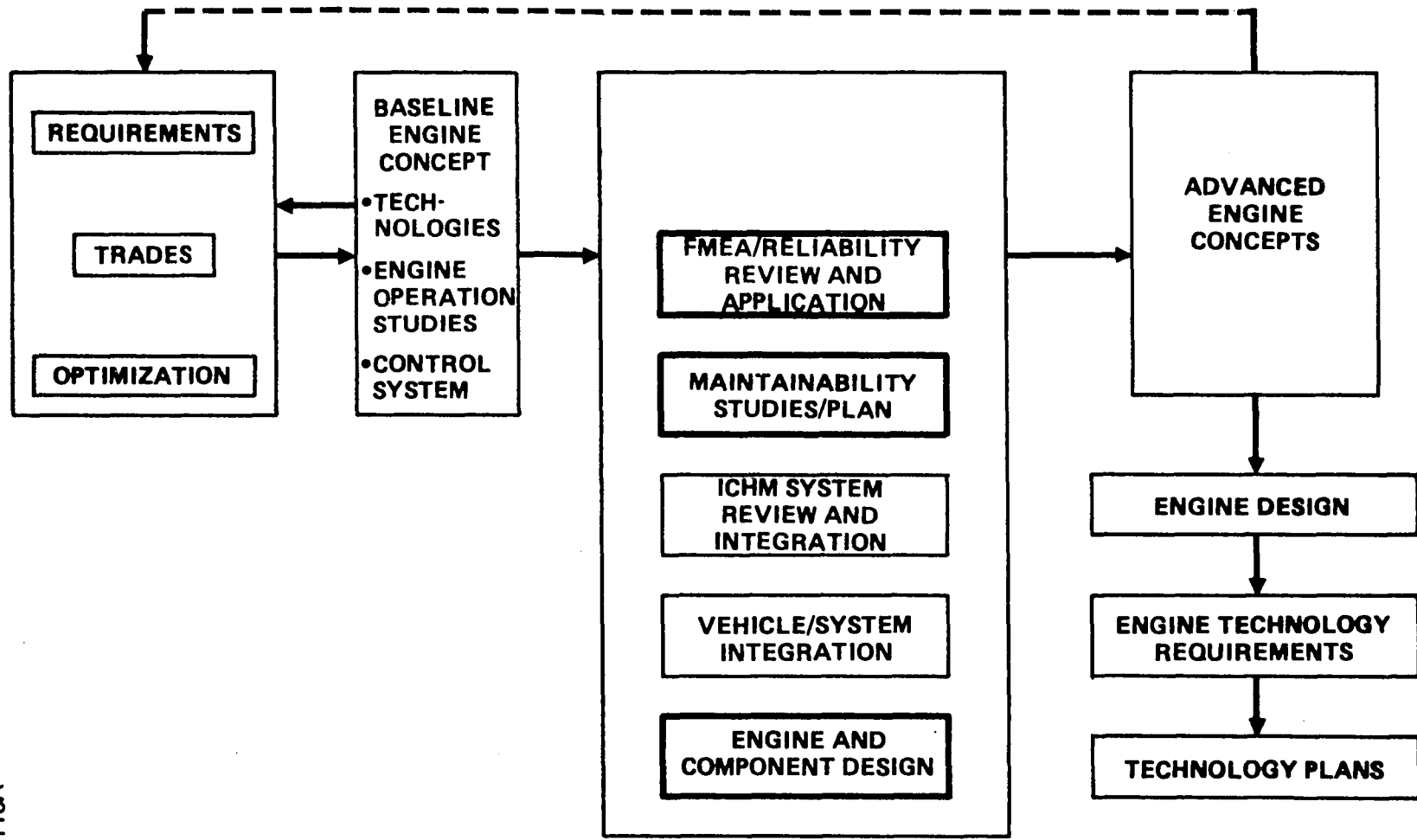

RI/RD86-116
9

491-110A

FIGURE 2.

IDENTIFICATION OF VEHICLE-DERIVED-REQUIREMENTS

In order to generate top down requirements for the engine system and for the Integrated Controls and Health Monitoring System (ICHM), a review of the information available from all vehicle contractors engaged in Phase A of the advanced Orbit Transfer Vehicle (OTV) definition and the Aeroassist OTV studies was conducted. The detailed data gathered in this review, presented in Appendix 1, represents the vehicle-derived requirements as perceived by the vehicle contractors in June 1984. Briefings and reports from Martin Marietta Corporation, Boeing Aerospace Corporation, General Electric and Grumman Aerospace Corporation were surveyed.

As expected, each vehicle contractor has their own unique approaches to the design of the OTV and to the establishment of propulsion system requirements. These varied approaches led in many instances to different vehicle-imposed engine requirements. The purpose of this survey was to identify requirements which are formulated by each vehicle contractor and try to define an acceptable compromise or consensus and, if the latter were not possible, establish an acceptable parameter range. This was to establish a foundation upon which the engine system and ICHM studies could be anchored and updated upon completion of OTV studies and selection by NASA of preferred approach.

In addition to the vehicle contractor survey, a review of the engine design driver missions was considered when establishing the engine requirements. A list of these driver missions, first flight dates, and rationale as foreseen in June 1984 is provided in Table 4.

Based on this information, the 1990's OTV engine requirements were established. A prioritized list of these requirements is presented in Table 5. Initially the OTV will be ground-based for early use with the Space Shuttle before the Space Station is operational. Upon completion of the Space Station, OTV operations will become space-based and will require man-ratable engines shortly thereafter. Life cycle cost (LCC) analyses indicate that propellant cost is the overwhelming expenditure over the life of the vehicle. Thus, the need for engines capable of high performance (I) over the full

ENGINE DESIGN DRIVER MISSIONS

MISSION TYPE	FIRST FLIGHT DATE	RATIONALE
MULTIPLE PAYLOAD DELIVERY 12876 UP 2166 DOWN	1993	PERFORMANCE DRIVER FOR GROUND-BASED OTV
MOLNIYA AND GPS MISSIONS	1993	MISSION OPERATION DIFFICULTY FOR SPACE-BASED OPERATION
UNMANNED SERVICE 7K UP 4.51K DOWN	1995	FIRST RENDEZVOUS AND DOCKING AUTONOMOUS RENDEZVOUS AND DOCKING DRIVES FLIGHT OPERATIONS AND EQUIPMENT COMPLEXITY
GEO DELIVERY 20K UP 0 DOWN	1996	EARLIEST REQUIRED MISSION MOST FREQUENT MISSION
GEO MANNED SERVICE 14K UP 14K DOWN	1997	ENERGY/PROPELLANT WEIGHT DRIVER PAYLOAD LENGTH IMPACT ON AEROASSIST MISSION DURATION (20 DAYS) MAN-RATING REQUIREMENTS
LUNAR DELIVERY AND RETURN 80K UP 15K DOWN	2006	PERFORMANCE DRIVER HIGHEST RETURN VELOCITY (12-21 DAYS)
PLANETARY 11.9071K C ₃ -60	2006	MISSION OPERATIONS: RETURN FROM BEYOND ESCAPE VELOCITY POSSIBLE PERFORMANCE DRIVER

RI/RD86-116

11

491-114



Rockwell
International
Rocketdyne Division

TABLE 4.

TABLE 5.

ENGINE REQUIREMENTS, 1990's OTV (PRIORITIZED)

- 1. SUITABLE FOR SPACE-BASING**
- 2. SUITABLE FOR GROUND-BASING**
- 3. SUITABLE FOR MAN-RATING**
- 4. HIGH Is AT LOW AND HIGH THRUST**
- 5. TANK HEAD IDLE START**
- 6. NO CONSTRAINTS ON COOL-DOWN TIME BETWEEN BURNS**
- 7. LIGHT WEIGHT**
- 8. SIZE COMPATIBLE WITH SERVICING/LIGHTWEIGHT**
- 9. COMPATIBLE WITH AEROASSIST OTV OPERATION**

RI/RD86-116

12

491-112



**Rockwell
International**
Rocketdyne Division

range of thrust (including throttled operation) is a necessity. With multiple burns expected during each mission, capability of tank head idle start is another requirement. The autogenous tank pressurization provided by tank head idle start eliminates the need for external tank pressurization systems.

In order to maintain the flexibility required in the mission profiles, no constraints on cool-down time between engine burns can be allowed. Though the impact of engine weight on LCC is not as significant as that of performance, it is still substantial enough to render low engine weight as another of the requirements to be fulfilled. The engine size and weight also effect servicing and maintenance. In order to be compatible with easy space-based repairs and replacements, the engine will have to be lightweight and compact. The final requirement identified in this review was engine compatibility with aeroassist OTV operations. This refers to the ability of the engine to retract and be stowed behind the OTV aerobrake upon return to low earth orbit.

Characteristics of the engine chosen to fulfill these requirements are summarized in Table 6. Included with the Phase A updates are the initial engine characteristics as determined in the Orbit Transfer Rocket Engine Technology Program completed in November 1983. The major change identified in the update is the reduction in the nominal thrust required. This reduction to two 7500 lb engines reflects revisions in the NASA Mission Model.

TABLE 6.

ENGINE CHARACTERISTICS — 1990's OTV

	<u>INITIAL</u>	<u>PHASE A UPDATES</u>
PROPELLANTS	LO ₂ /LH ₂	✓
THRUST, lb		
NOMINAL	10,000 – 25,000	7500
LOW THRUST	2,000	✓
THROTTLING (CONTINUOUS)	NONE	✓
THRUST BUILDUP TIME, sec	1 – 2	✓
BOOST PUMPS		
VEHICLE	NONE	✓
ENGINE	LOW NPSH	✓
APPLICATION COMPATIBILITY	AFT CARGO CARRIER, AEROASSIST	✓
STOWED SIZE, in.		
ENGINE LENGTH	55	60
ENGINE DIAMETER	71	✓
THRUST VECTOR CONTROL, deg.	±4	+6
INERT GAS REQUIREMENT		
VALVE ACTUATION	HELIUM	✓
PURGES	NONE	✓

R1/RD86-116

14

491-113A



Rockwell
International
Rocketdyne Division

BASELINE ENGINE DEFINITION

ADVANCED COMPONENT TECHNOLOGIES

After establishing the vehicle derived requirements, numerous trade studies and optimizations were conducted in order to define a baseline engine. The engine concept generated in that effort is a 7.5K high performance LOX/LH₂ expander cycle thruster. This baseline design, presented in Figure 3, attains a specific impulse of 490.4 seconds at a chamber pressure of 1831 psia. Several advanced component technologies are incorporated into the baseline engine. With the expander cycle using hydrogen heated in the combustor and nozzle coolant circuits as turbine drive gas, a high heat-load extraction combustor is one of the key component technologies required to attain high performance. The injector/combustor must also achieve high combustion efficiency and have a long life compatible with the engine life goal of 500 cycles or 20 hours. A high area ratio nozzle will be required to achieve maximum specific impulse from the high available chamber pressure. This nozzle must not only be lightweight, but also be retractable to meet the stowed engine length requirement of only 60 in. The lower segments of the nozzle may be radiation-cooled and could be composed of a silicon carbide coated carbon-carbon composite. The upper segment will be regeneratively cooled and thus will require remote coolant fluid interconnects for retractability. The mechanical retraction/extension device will be of a simple design providing reliable service over a long life. Another advanced technology necessary to meet the very high engine performance requirements is high-speed, multistage turbomachinery. These components will be made with lightweight, high strength materials to provide long lives at the elevated speeds required to attain high turbine and pump efficiencies. Space operable fluid disconnects may be required for space-based engine maintenance. These disconnects would have to be lightweight, highly reliable and capable of easy and quick operation by an astronaut during EVA or by remote robotics. Another advanced technology component which may be needed is a turbine gas regenerator. If the high combustor heat extraction rates required to drive the expander cycle are not

BASELINE OTV ENGINE

7500 LB THRUSTER

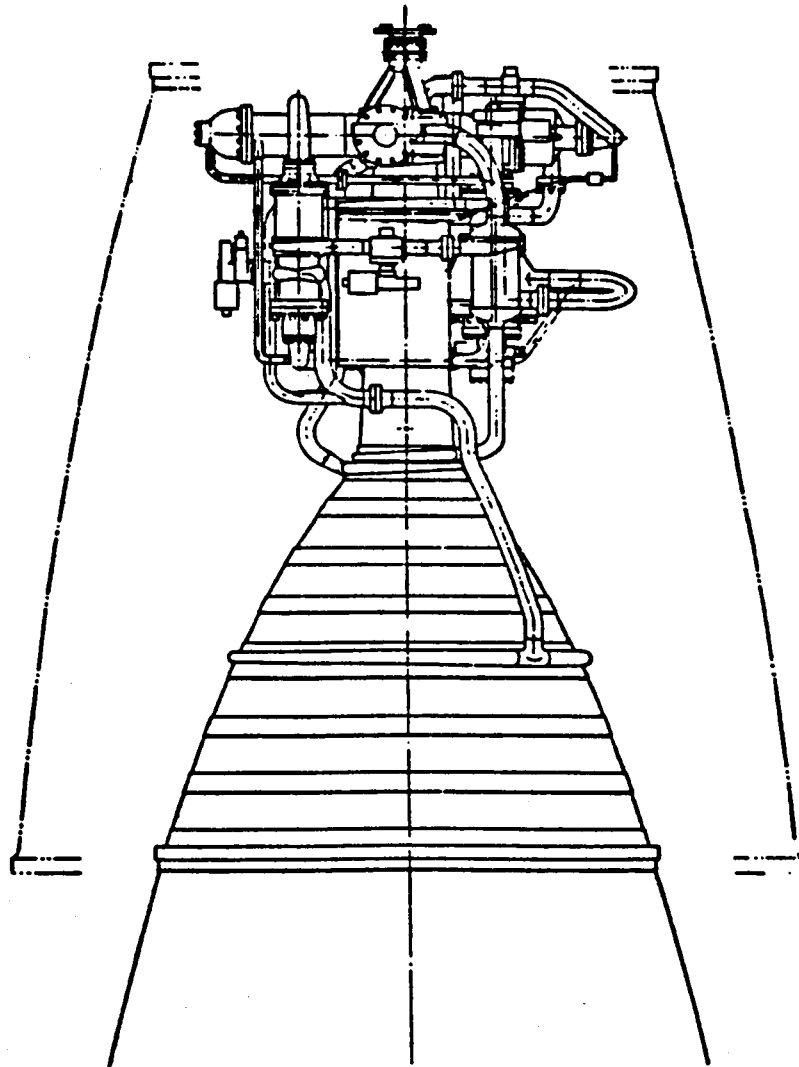

THRUST, LB _____ 7500
CHAMBER PRESSURE, PSIA _____ 1831
AREA RATIO _____ 1080
SPECIFIC IMPULSE, SEC _____ 490.4
LIFE, CYCLES/HR _____ 500/20
ENGINE LENGTH, IN _____ 117

RI/RD86-116

16

491-116

 **Rockwell
International**
Rocketdyne Division

FIGURE 3.

achievable, it may become necessary to boost the turbine drive gas temperature through the use of a regenerator. By placing a heat exchanger between the cooling jacket inlet and the turbine discharge, heat is transferred from the turbine exhaust gas to the coolant. In this manner, the turbine inlet temperature is elevated resulting in increased turbine power. A study (Appendix 3) has shown that a regenerator is undesirable, but should it become necessary, it would have to be compact, lightweight and provide high heat transfer efficiency. Components in the control and diagnostics area will also incorporate new technologies. Advanced sensors and engine controllers play a key role in ICHM system upon which the space-based maintenance philosophy is founded. As with the other technologies mentioned, these components must also be compact and lightweight while providing reliable operation over a long life. A summary of the advanced technologies incorporated in the baseline engine is provided in Figure 4.

ENGINE PERFORMANCE OPTIMIZATION

The features of the baseline were determined through a series of optimization runs in which the performance impact of various design changes were evaluated. The engine design parameters and features investigated include: (1) turbomachinery tip speed and stress limits, (2) combustor cooling jacket type, (3) turbine staging and admission, (4) pump staging, (5) fuel pump wheel speed limit, (6) gaseous hydrogen drive for the low-pressure oxidizer turbine (LPOT), (7) use of a turbine gas regenerator, (8) soft wear ring seals in pumps, and (9) gaseous oxygen driven LOX turbopumps.

Table 7 summarizes the performance optimization results for the advanced technology engine at 7500 lb thrust. The initial reference engine is shown in the first column of the table. Design features of this engine are a ribbed combustor, a 4-stage high-pressure fuel pump, a 2-stage partial admission high-pressure fuel turbine, a single stage high-pressure oxidizer turbopump and a full-flow hydraulic driven low-pressure oxidizer turbine. Except for the absence of soft wear ring seals, this reference engine is identical to the baseline engine that was eventually chosen. A detailed discussion of each engine performance optimization case as enumerated above is provided below.

7.5K ENGINE COMPONENT TECHNOLOGIES

● HIGH HEAT-LOAD COMBUSTOR/INJECTOR

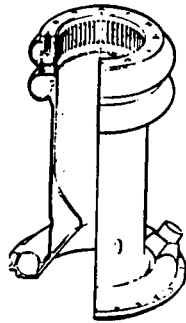

- HIGH Q EXTRACTION
- LONG LIFE
- HIGH COMB. EFF.

● HIGH AREA RATIO NOZZLE

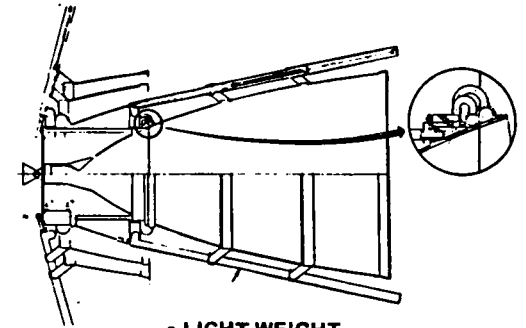

- LIGHT WEIGHT
- LONG LIFE
- SIMPLICITY/RELIABILITY

STS/SPACE-BASED OTV

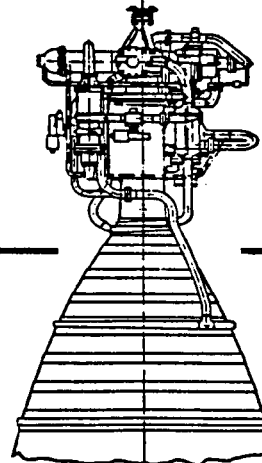

● HIGH-SPEED, MULTI-STAGE TURBOMACHINERY

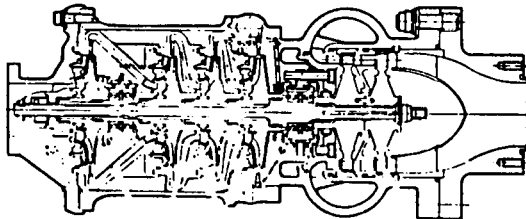

- LIGHT WEIGHT
- ROTORDYNAMICS
- LONG LIFE
- HIGH STRENGTH MATL'S

● ADVANCED CONTROL AND DIAGNOSTICS

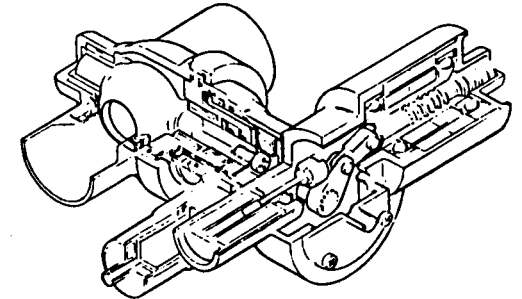

- RELIABILITY/SIMPLICITY
- COMPACTNESS
- LIGHT WEIGHT
- LONG LIFE
- COST

● ADVANCED COUPLINGS

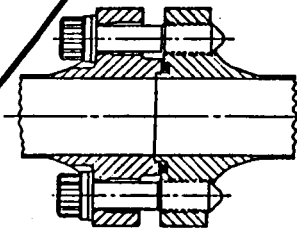

- SPACE OPERABLE
- HIGHLY RELIABLE
- LIGHT-WEIGHT

● TURBINE-GAS REGENERATOR

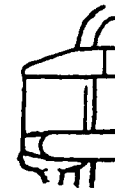

- HEAT TRANSFER EFF.
- COMPACTNESS
- LIGHT WEIGHT

RI/RD86-116

18

491-154

 **Rockwell International**
Rocketdyne Division

FIGURE 4.

TABLE 7.
RESULTS SUMMARY OF ENGINE OPTIMIZATION RUNS FOR ADVANCED TECHNOLOGY ENGINE AT 7500 LB THRUST

ENGINE PARAMETERS	REFERENCE	CASE NUMBER										CHOSEN AS BASELINE
		1	2	3	4-0	5	4-F	6	7	8	9	
TURBOMACHINERY LIMITS	ADV. (1)	S.O.A(2)	S.O.A.	ADV.	ADV.	ADV.	ADV.	ADV.	ADV.	ADV.	ADV.	ADV.
COMBUSTION TYPE	RIBBED	RIBBED	<u>TAPERED</u>	RIBBED	RIBBED	RIBBED	RIBBED	RIBBED	RIBBED	RIBBED	RIBBED	RIBBED
NO. OF HPFT STAGES	2	2	2	1	2	2	2	2	2	2	2	2
HPFT ADMISSION	PARTIAL	PARTIAL	PARTIAL	<u>FULL</u>	PARTIAL	PARTIAL	PARTIAL	PARTIAL	PARTIAL	PARTIAL	PARTIAL	PARTIAL
NO. OF HPOP STAGES	1	1	1	1	2	1	1	1	1	1	1	1
NO. OF HPFP STAGES	4	4	4	4	4	4	3	4	4	4	4	4
HPFP SPEED LIMIT, RPM	200000	200000	200000	200000	200000	300000	<u>300000</u>	200000	200000	200000	200000	200000
LPOT DRIVE TYPE	F-F (3)	F-F	F-F	F-F	F-F	F-F	F-F	<u>GH2</u>	F-F	F-F	F-F	F-F
SOFT WEARL SEALS	N/A	N/A	N/A	N/A	N/A	N/A	N/A	N/A	N/A	N/A	YES	YES
GOX DRIVE	N/A	N/A	N/A	N/A	N/A	N/A	N/A	N/A	N/A	N/A	N/A	YES
CHAMBER PRESSURE, PSIA	1576	1387	1215	1214	1515	1626	1478	1534	1565	1831	1741	1741
SPECIFIC IMPULSE, SEC	488.86	487.7	484.94	486.53	488.34	489.16	488.32	488.64	488.82	490.4	486.0	486.0
NOZZLE AREA RATIO	970	1042	909	914	847	994	975	1107	1048	1081	976	976
HPFT BYPASS, PERCENT	10	10	10	10	10	10	10	10	10	10	10	10
HPFTP EFF. PRODUCT, %	31.39	30.71	34.84	27.9	31.57	32.06	32.86	31.35	30.24	34.49	32.07	32.07
COMB. HEAT LOAD, BTU/SEC	6440	6402	3965	6366	6425	6453	6432	6432	6430	6502	6356	6356
NOZZLE HEAT LOAD, BTU/SEC	1416	1561	1721	1687	1428	1392	1485	1461	1431	1293	2019	2019
REGEN. HEAT LOAD, BTU/SEC	N/A	N/A	N/A	N/A	N/A	N/A	N/A	N/A	43	N/A	N/A	N/A
HPFP SPEED, RPM	199661	118733	133255	200000	198894	247254	296159	195367	199345	199560	200000	200000
HPFP EFFICIENCY, PRCENT	48.98	48.44	53.76	55.46	49.25	50.18	52.24	49.07	47.77	56.38	62.63	62.63
HPFP DIS. PRESSURE, PSIA	6559	5078	4164	4058	6472	6895	5335	6540	6908	7733	5747	5747
HPFP DIAMETER, IN.	2.36	3.37	2.67	1.81	2.35	1.97	1.65	2.38	2.45	2.44	2.15	2.15
HPFP TIP SPEED, FT/SEC	2057	1749	1552	1580	2039	2128	2134	2032	2131	2125	1877	1877
HPFT PRESSURE RATIO	2.23	1.91	1.97	1.8	2.20	2.27	1.89	2.22	2.38	2.31	3.02	3.02
HPFT EFFICIENCY, PERCENT	61.4	63.4	64.8	50.3	64.1	63.9	62.9	63.9	63.3	61.9	51.2	51.2
HPFT DIAMETER, IN.	1.99	2.95	2.33	2.21	2.16	1.81	1.30	2.05	2.05	2.14	2.08	2.08
HPFT VELOCITY RATIO	.262	.258	.268	.346	.288	.292	.287	.266	.26	.276	.271	.271
HPFT BLADE HEIGHT, IN.	.273	.29	.368	.087	.259	.198	.155	.259	.245	.243	.120	.120
HPFT ADMISSION, FRACTION	.225	.198	.181	1.0	.218	.321	.806	.228	.226	.395	.775	.775
HPFT AN**2, (IN-RPM)**2 E-10	9.72	5.04	6.46	2.56	9.92	9.98	7.35	9.12	9.29	6.51	3.12	3.12
HPFT DN, (MM-RPM) E-6	2.92	1.87	1.90	2.54	2.9	3.45	3.68	2.87	2.97	2.92	2.67	2.67
HPFT INLET TEMP., DEG-R	1129	1121	795	1103	1125	1129	1112	1133	1143	1119	890	890
HPFT PITCH VELOCITY, FT/SEC	1731	1529	1357	1931	1881	1951	1679	1752	1788	1863	1814	1814

(1) RELAXED TO A HIGHER VALUE
(2) PARAMETER CHANGE UNDERLINED
(3) FULL-FLOW HYDRAULIC DRIVE

19
RI/RD86-116

Case 1: Turbomachinery Tip Speed and Stress Limits

This case, when compared to the reference case, indicates the benefits of advanced state-of-the-art turbomachinery tip speed and stress limits. In the reference case, the limits are relaxed to the higher values indicated in Table 8. Implementation of the advanced turbomachinery limits will require hybrid hydrostatic bearings and improved materials. With the same turbine inlet temperature, the increased tip speed and stress limits allows the wheel speed to be sharply increased. This results in better turbomachinery efficiencies and hence, higher chamber pressure, higher engine performance and smaller engine envelope. The chamber pressure advantage from advanced turbomachinery limits is 360 psia.

TABLE 8. TURBOMACHINERY TIP SPEED AND STRESS LIMITS

TURBOMACHINERY LIMIT		1980	
		S.O.A. (1)	ADVANCED
BEARING DN	(mm-RPM)	1.9×10^6	NONE
TURBINE PITCH LINE VELOCITY	(ft/sec)	1600.	2000
PUMP TIP SPEED	(ft/sec)	1870.	2200
ANNULUS AREA x N ²	(in-RPMM) ²	8x10	10×10^{10}

Case 2: Combustor Cooling Jacket Configuration

Replacing the tapered smooth-wall combustor with an advanced ribbed combustor significantly increases the coolant heat load which increases the power available to the turbine. This results in a higher chamber pressure and specific impulse. A ribbed combustor provides about 60% more heat load than a tapered combustor (Case 2 compared to Case 1) and results in a chamber pressure increase of 170 psia. In support of this effort, point designs of the combustor and nozzle coolant jacket were generated.

Contours for both the combustor and nozzle were first determined. The combustor geometry was then subjected to a boundary layer analysis to determine hot-gas heat transfer coefficient profiles and to a thermal analysis to determine coolant-channel geometry heat loads and coolant pressure drop for the required life of 1200 cycles. Details of the point design are presented in Appendix 2.

Case 3: Turbine Staging and Admission

The use of a single stage full admission high-pressure fuel turbine reduces the engine chamber pressure and specific impulse significantly because of two effects. First, the full arc of admission significantly reduces the turbine blade height. Second, the single stage turbine requires a higher stage pressure ratio which reduces the blade height further. The large decrease in blade height results in a heavy penalty on the turbine efficiency and hence, a significant loss in engine performance. If speed wasn't held at 200,000 rpm as a limit, it would also have required higher speeds for the same turbomachinery limits. A 14 point turbine efficiency deficit is created which reduces chamber pressure by 362 psia from the reference case.

Case 4: Pump Staging

An increase in the number of main fuel pump stages results in a definite increase in the pump discharge pressure. This consequently raises the turbine pressure ratio such that the increased pump power requirement can be met. The increase in turbine pressure ratio is not large enough to offset the increase in the pump discharge pressure so that a significant increase in chamber pressure results (148 psia, compare Case 4-F and 5).

The oxidizer pump staging has a smaller and opposite impact on the engine performance than the fuel pump. Increasing the oxidizer pump staging from one to two results in a decrease in chamber pressure (61 psia) and in specific impulse (compare Case 4-D to reference).

Case 5: Fuel Pump Wheel Speed Limit

For most cases considered, fuel pump rpm was limited to 200,000. An increase over this limit does increase the optimum pump operating speed, but, results in a very small increase in the turbomachinery efficiencies since the tip speed and stress limits are unchanged. Therefore, the impact of pump wheel speed limit on the engine performance is not significant (compare Case 5 with the reference case).

Case 6: Gaseous Hydrogen Drive for LPOT

In this configuration, a gaseous hydrogen driven low-pressure-oxidizer turbine (LPOT) located in parallel with the high-pressure oxidizer and low-pressure fuel turbines is used to replace the full-flow hydraulically driven LPOT. This arrangement would allow operation of boost pumps in the tank-head idle mode to speed up engine conditioning. Since the power required by the low-pressure oxidizer pump is very small, the impact of gaseous hydrogen drive for the LPOT on engine performance is not significant. Although the use of gaseous hydrogen drive for the LPOT can be advantageous during engine start, additional inter-propellant seals would be required for the low-pressure oxidizer turbopump.

Case 7: Turbine Gas Regenerator

The benefit of adding a turbine gas regenerator between the cooling jacket inlet and turbine discharge was also investigated for the reference engine. The purpose of the regenerator is to transfer heat from the turbine exhaust gas to the coolant, increasing the turbine inlet temperature and in that manner increase turbine power. The increase in combustor coolant inlet temperature, however, increases the coolant velocity through the cooling jacket which results in a large jacket pressure loss. The large pressure loss experienced in Case 7 offsets the benefits which resulted from regeneration. A detail optimization of the coolant jacket channel design at this particular condition is required before a final answer can be given in this area. An additional study was conducted subsequently in which reduced jacket pressure drops were investigated. Details of this study are presented in Appendix 3. Results of this study show that with the added

complexity and engine weight, the minimal increases in performance gained do not warrant the use of a hydrogen recuperator even if major reductions in the combustor coolant jacket pressure drop were possible.

Though these investigations indicate that a hydrogen regenerator is not desirable, it still may become necessary should the combustor heat extraction rates prove to be insufficient. Therefore, the recuperator will still be included as an option to be further considered.

Case 8: Soft Wear Ring Seals

The high-speed OTV turbopumps are relatively small and clearances between stationary and rotary parts become a significant percentage of the flow passage area. The resulting parasitic leakage flow losses can be reduced by close clearances. Soft-seal polymer materials offer the potential of extremely close-clearance wear rings with elimination of metal-to-metal rubbing and its adverse consequences on the propellants and rotating parts. Based on detailed efficiency loss analysis of two configurations using very small clearances (order of one thousandth), a correlation was developed for prediction of OTV pump efficiencies using soft seals.

The performance was improved significantly over that of the reference engine by inclusion of soft wear ring seals. Based on this improvement, Case 8 was chosen as the baseline OTV engine upon which all subsequent studies were conducted.

Case 9: Oxygen Drive HPOT

In this case, an engine utilizing a gaseous oxygen driven LOX turbopump was investigated. For this configuration, the energy for the turbine drive gas is supplied by heating the oxygen in the nozzle cooling circuit. The LH₂ turbopump is still driven by hot hydrogen gas but this drive gas is heated only in the combustor cooling circuit. Soft wear ring seals were also included in this case, therefore, performance is to be compared with the baseline engine (Case 8) as opposed to the reference engine. Significant decreases in performance for the oxygen driven HPOT case were observed. Chamber pressure is down 690 psia and specific impulse down 4.4 seconds with respect to the baseline configuration. The poor performance exhibited by

the oxygen driven case is due to the limited amount of energy provided to the oxygen in the nozzle cooling circuit. If additional energy could be supplied to the oxygen, possibly with injector heat exchanger baffles, this performance would improve.

In summary, based on the series of optimization studies described above, Case 8 was chosen as the baseline OTV engine. A description of this engine including salient features and performance characteristics is provided in Table 9.

ENGINE THRUST STUDY

After definition of the baseline 7.5K engine, a study was conducted to evaluate the effect of thrust upon engine weight, length and performance. For this effort the technology level was held constant. A fixed overall nozzle expansion ratio of 1000:1, percent length of 90% and breakpoint ϵ (regen-erative to radiation cooled) of 450 was used. These fixed values were chosen from the optimized 7.5K baseline engine. The purpose of this study was to supply the vehicle contractors with parametric data should required engine thrust level change due to revisions in NASA's OTV mission model.

Engine performance drops off significantly at the lower thrust levels due to lower turbopump efficiencies and greater kinetic losses. Single engine weight increases linearly with thrust. Detailed results of this study are presented in graphical form in Appendix 4. Other parameters addressed include engine cluster weight, payload, chamber pressure, engine envelope, and turbopump efficiencies.

CONTROL SYSTEM ASSESSMENT

The control system for the baseline engine was evaluated. Four engine control system concepts, Table 10, were assessed to determine the one most suitable for near-term OTV engine. Based on the functional control aspects and other features, including cost, full range controls were considered to be the most desirable choice.

TABLE 9. BASELINE ENGINE DESCRIPTION

- ADVANCED TURBOMACHINERY LIMITS
- HIGH HEAT-LOAD RIBBED COMBUSTOR
- TWO-STAGE PARTIAL ADMISSION FUEL TURBINE
- FOUR-STAGE HIGH PRESSURE FUEL PUMP
- SINGLE STAGE HIGH PRESSURE OXIDIZER PUMP
- FULL FLOW HYDRAULIC DRIVEN LOW-PRESSURE OXIDIZER TURBINE
- HYDROGEN REGENERATOR (IF REQUIRED)
- SOFT WEAR RING SEALS ON PUMPS
- HYDROGEN DRIVEN OXIDIZER TURBOPUMP

CHAMBER PRESSURE, PSIA	1831
SPECIFIC IMPULSE, SEC	490.49
% LENGTH*	94

NOZZLE AREA RATIO	1081
HPFT BYPASS, PERCENT	10
HPFTP EFF. PRODUCT, %	34.9

Δh_f , HEAT OF FORMATION, Kcal/gmol	1.62
COMB. HEAT LOAD, BTU/SEC	6502
NOZZLE HEAT LOAD, BTU/SEC	1293

	LOX	LH ₂
<u>MAIN PUMPS:</u>		
SPEED, RPM	63313	199560
EFFICIENCY, PERCENT	69.69	56.38
DIS. PRESSURE, PSIA	3119	7733
DIAMETER, IN.	2.37	2.44
TIP SPEED, FT/SEC	654	2125
SPECIFIC SPEED	865	749
<u>MAIN TURBINES:</u>		
PRESSURE RATIO	1.16	2.31
EFFICIENCY, PERCENT	61.5	61.9
PIT DIAMETER, IN.	4.05	2.14
VELOCITY RATIO	.41	.28
1ST BLADE HEIGHT, IN.	.27	.14
ADMISSION, FRACTION	.264	.395
AN**2, (IN-RPM) **2 E-10	1.579	6.506
DM, (MM-RPM) E-6	.743	2.923
INLET TEMP., DEG-R	982	1119
PITCH VELOCITY, FT/SEC	1119	1863

TABLE 10. ENGINE CONTROLS SYSTEM CONCEPTS DEFINITION

A. MINIMUM ELECTRONIC SYSTEMS

NO CONTROLLER
MECHANICAL SEQUENCING
MONITORING INSTRUMENTATION FOR REUSABLE ENGINE
REDLINE MONITORING FOR MAN-RATING
CHECKOUT BY OFF-ENGINE MEANS

B. OPEN LOOP

ELECTRICAL SEQUENCE CONTROL
NO VALVE POSITIONING CONTROL
MONITORING INSTRUMENTATION AND REDLINE MONITORING
CHECKOUT AND STATUS MONITORING ON ENGINE

C. MAINSTAGE TRIM CONTROLS

ELECTRICAL SEQUENCE CONTROL
NO VALVE POSITIONING CONTROL DURING START AND SHUTDOWN
MONITORING INSTRUMENTATION AND REDLINE MONITORING
PERFORMANCE INSTRUMENTATION
FEEDBACK DURING M/S TO TRIM F & MR
CHECKOUT AND STATUS MONITORING BY ENGINE

D. FULL RANGE CONTROLS

CONTROLLER PERFORMING VALVE POSITION CONTROL
FEEDBACK TO CONTROL F & MR AS REQUIRED
MONITORING INSTRUMENTATION AND REDLINE MONITORING
PERFORMANCE INSTRUMENTATION
CHECKOUT & STATUS MONITORING BY ENGINE

The near-term control system for the OTV advanced expander cycle engine includes a variety of components, and impacts all phases of engine operation. Therefore, the selection of this system must consider a wide range of related areas. Specific areas of assessment included: control point selection, steady state performance, starts and shutdown, redundancy issues, controller, valves, actuators, and instrumentation. This near-term control system constitutes the baseline system from which the advanced ICHM will evolve.

Control Point Selection

Figure 5 is a simplified schematic showing only the primary flow paths. The recommended primary control points are the main oxidizer valve (MOV) and the turbines bypass valve (TBV) which control the mixture ratio and thrust, respectively. The main fuel valve (MFV) is used for start and shutdown control and the oxidizer turbine bypass valve (OTBV) is used to achieve satisfactory operation during powered idle mode. The selection of the MOV and TBV as the main control points was based on a sensitivity analysis conducted on the 7.5K engine.

Though the MFV is a good thrust control point and would obviate the TBV, the additional pressure loss introduced is greater a penalty than the benefits gained by removing the TBV flow. In addition, pump inlet shutoff-isolation valves could not be used for thrust or mixture ratio control without causing pump cavitation. Thus the MOV and TBV are the logical control point selections.

Steady-State Performance

An engine with no feedback control (open loop) should be expected to experience 20% thrust variations over the life of the engine and 7% thrust variations with a given mission, while a closed loop controlled engine could be expected to maintain thrust within 2%. Similarly, mixture ratio (MR) could be controlled to within 0.1 unit over the engine life with feedback control, but if ran open loop, the engine could experience a 0.3 unit variation in a given mission and 0.8 unit variation over the life of the engine. A summary of the variations is presented in Table 11.

FIGURE 5. SERIES TURBINE BASELINE OTV ENGINE SCHEMATIC -
MAIN PROPELLANT CONTROL VALVES

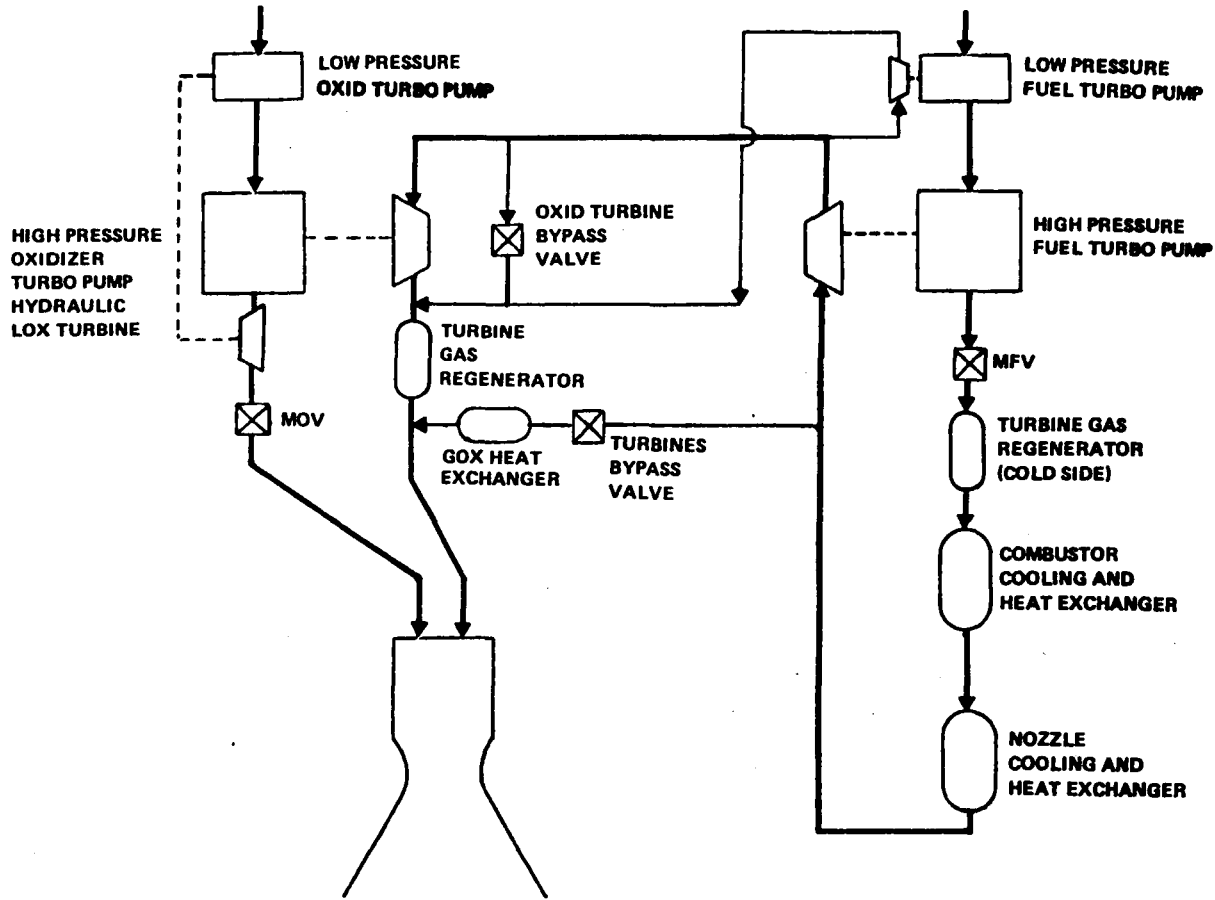

TABLE 11. EXPANDER CYCLE PERFORMANCE

ENGINE CONTROL CONCEPT	IN-RUN AND RUN-TO-RUN		IN RUN	
	THRUST VARIATION	MR VARIATION	THRUST VARIATION	MR VARIATION
OPEN-LOOP (A & B)	20%	0.8 UNITS	7%	0.3 UNITS
CLOSED-LOOP (C&D)	2%	0.1 UNITS	2%	0.1 UNITS

Start and Shutdown

Start and shutdown impose extreme operating conditions on the engine and maintaining proper relationships of pressures and temperatures is extremely important for reliability and long life of the 7.5K engine system. Positioning and controlling the engine system valves properly can be realistically accomplished only with an electronic controller. Twenty-two valves on the engine must be sequenced to open or close in the correct sequence during start, mainstage and shutdown. Actuator requirements, as defined in Table 12, result in actuator types for engine control that cannot be open loop positioned. Some type of position control must be employed to ramp the valves slowly and reliably, in a repeatable manner. It must also be able to adapt as new requirements are generated or system limits and problems are encountered. Thus, start and shutdown requirements not only define an electronic sequence controller, but a valve position control and reference command capability. Even though sequence and valve position control are required, no closed loop operation appears to be required for start and shutdown. However, with valve position control available, closed loop engine control can be implemented during any other phase of engine operation where closed loop control may be required, such as for MR control during mainstage.

TABLE 12. ACTUATOR REQUIREMENTS

ENGINE CONTROL CONCEPT	VALVE	POSITIONING REQUIREMENTS		
		SLEWRATE - PRECISION		
		START	CUTOFF	MAINSTAGE
A	MFV	Ramp between stops 75%/SEC±25%/SEC	Same as Start	Full Open
	MOV	20%/SEC±5%/SEC, ±2 1/2% 2 intermediate positions	50%/SEC±10%/SEC ramp closed	± 1/2%
	TURB BYPASS	40%/SEC±10%/SEC, ±2 1/2% 2 intermediate positions	No Req'mt	± 1/2%
	OXID TURB BYPASS	60%/SEC±40%/SEC, ±2 1/2% 1 position besides open	No Req'mt	± 1/2%
B	(SAME AS "A" ENGINE FOR ALL REQUIREMENTS)			
C	MFV	START AND CUTOFF		Full Open
	MOV	HAVE SAME		0.5% resolution
	TURB BYPASS	REQUIREMENTS AS "A"		0.5% resolution
	OXID TURB BYPASS			0.5% resolution
D	MFV	(SAME AS "A" ABOVE)		Full Open
	MOV	50%/SEC with 0.5% Resolution		0.5% resolution
	TURB BYPASS	50%/SEC with 0.5% Resolution		0.5% resolution
	OXID TURB BYPASS	50%/SEC with 0.5% Resolution		0.5% resolution

The advantages of full range controls also apply to start and shutdown operation as can be seen in Table 13.

Redundancy

Four control system redundancy configurations were evaluated. The dual-dual cross-strapped system, Figure 6, was chosen as the most desirable. In evaluating the redundancy requirements, the ultimate issue is mission success. To achieve success, components must be reliable enough to work for the entire duty life, or redundancy must be provided for failed components. In examining the control system components, the controller itself is extremely reliable regardless of having to operate several hours for each hot fire test. Even with the high level of reliability of the controller, electronics are subject to random failure, thus some kind of redundancy for the controller is still required.

At the other extreme, engine system sensors experience a relatively high rate of failure due to the severe environments associated with the sensing locations. Thus additional redundancy for critical sensors is required. Reliability data from the SSME was used as a guide in performing this evaluation.

Power Distribution

The power distribution system inherently does not lend itself to the variety of options afforded to other aspects of the control system. For example, while controller subsystems such as the computers and input-outputs electronics can be reduced greatly in size by using the latest microelectronic technology, the power supply is not very amenable to miniaturization.

TABLE 13. EXPANDER CYCLE ENGINE START AND SHUTDOWN REQUIREMENTS

ENGINE CONTROL CONCEPT	<u>OPERATIONAL CHANGES</u>	<u>TEST VARIATIONS</u>
A	CHANGES REQUIRE MECHANICAL PARTS TO BE REDESIGNED	TEST-TO-TEST VARIATIONS MUST BE ACCEPTED OR COMPLEX MECHANICAL COMPENSATION SYSTEMS DESIGNED AND DEVELOPED.
B	SEQUENCE TIME CAN BE PROGRAMMED. OPENING RATES OR AREA CHANGES OF CONTROL POINTS REQUIRE MECHANICAL PART REDESIGN	TEST-TO-TEST VARIATIONS MUST BE ACCEPTED OR COMPLEX MECHANICAL COMPENSATION SYSTEMS DESIGNED AND DEVELOPED.
C	SEQUENCE TIMES CAN BE PROGRAMMED. OPENING POINTS REQUIRE MECHANICAL PART REDESIGN	TEST-TO-TEST VARIATIONS MUST BE ACCEPTED OR COMPLEX MECHANICAL COMPENSATION SYSTEMS DESIGNED AND DEVELOPED.
D	CAPABLE OF ADAPTING TO LARGE CLASS OF REQUIRED CHANGES BY CHANGES TO SOFTWARE	CONTROL CAN BE USED TO ABSORB VARIATIONS.

Figure 6. Dual-Dual Redundant Cross-Strapped Systems

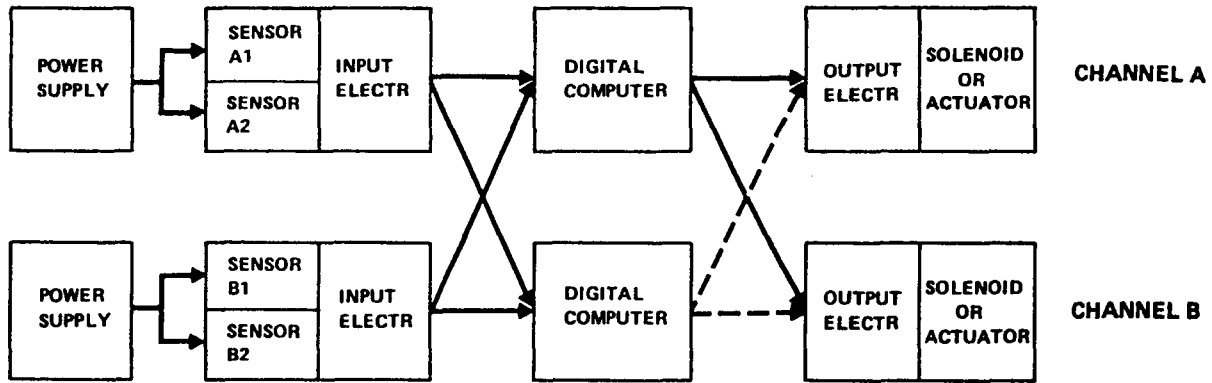

PRO

- GREATEST CHANCE OF MISSION SUCCESS
- STRENGTHENS WEAKEST LINK
- SOME EXPERIENCE ON SSME

CON

- NOT FO/FO/FS AT ALL LEVELS



The distribution configurations that were evaluated include: (1) AC/DC power conditioning by controller; (b) direct DC from stage, power conditioned by controller; and (c) direct DC to controller, actuator, solenoids and igniters. Configuration (c) requires the smallest power supply and is the recommended option for the 7.5K engine. However, vehicle design factors, such as locations of the fuel cells, must be considered before the physical characteristics of the power distribution system, such as size, weight, and voltage, can be resolved.

Controller

Associated with the four control system concepts of Table 10, four controller options were considered: (a) no controller; (b) minimum controller with open loop engine controls; (c) controller with mainstage trim controls; and (d) a full range controller with closed loop engine controls. When total engine performance, reliability, cost and other considerations as indicated in Table 10 are taken into account, option (d) becomes the most desirable choice.

Valves

An evaluation was conducted to define the type of valves best suited for each location required. A total of 30 valves and controls were identified for complete engine control. They are summarized by valve type, location and quantity in Table 14.

Actuators

The actuator requirements for the primary control points were defined in Table 12 for the four control options considered. It is recommended that the primary control point actuators be electrically actuated and have a pneumatic backup. Electric actuators provide the positive, repeatable, position control required for reliable and repeatable start and shutdown. The electric actuators also lend themselves to actuator redundancy. Redundant electric actuators, though, would require additional weight and complexity.

TABLE 14. VALVE SUMMARY

VALVE TYPE	QUANTITY
• BALL VALVES, HIGH PRESS., PNEUMATICALLY ACTUATED (1) MFV, (5) GOV	2
• BALL VALVES, HIGH PRESS., SERVO-ACTUATED (2) MOV, (3) FTBV, (4) OTBV	3
• PROPELLANT ACTUATED VALVE (7) H/E SHUNT VALVE	1
• PROPELLANT SOLENOID VALVES (6) CCV, (8) & (9) IGNITER VALVES	3
• TANK PRESS. CHECK VALVES, (10) & (11)	2
• PREVALVE BALL VALVES, (12) & (13)	2
• PURGE SOLENOID & CHECK VALVES (14-23)	10
• PNEUMATIC CONTROL SOL. VALVES & SERVOS (24, 25, 26, 27, 28, 29, 30)	7
	—
	30 TOTAL

THROTTLING AND STABILITY

Off-design operation of the 7.5K lb thrust baseline was examined using an off-design computer model. The objective of this study was to establish the range of throttling free of pump and feed system instability. Thrust levels in the range of 10-100 percent of nominal and mixture ratios in the range 4-7 were examined. Ideal pump HQ characteristics were used. These will be updated when point-design characteristics are available. No attempt was made to assess pump critical speed impact on throttling, since detail pump design is not available yet. Results of the study are summarized in Table 15.

TABLE 15. OTV 7.5K ENGINE OFF-DESIGN SUMMARY

OFF-DESIGN THRUSTS AND MIXTURE RATIOS		
THRUST (% OF NOMINAL)	MIXTURE RATIO	PREDICTED ENGINE OPERATION
100	7	STABLE
20	6 OR LESS	STABLE
12	6	UNSTABLE
12	4 OR LESS	STABLE
10	4	STABLE

All operating points examined are also shown on the high pressure fuel pump H-Q map in Figure 7. Stable operation is predicted at nominal thrust and mixture ratio of 7:1. This mixture ratio is an off-design vehicle requirement.

At a mixture ratio of 6:1 the engine will operate stably down to a thrust level of 20 percent of nominal value. This is indicated in Figure 7 by a pump operating point to the right of the zero-slope line of the H-Q curves. As indicated by the 12 percent thrust point, the zero-slope line is intercepted at a thrust level below 20 percent of nominal.

Stable operation below 20 percent thrust level is achieved by lowering mixture ratio to 4:1 or below. In the interest of maintaining high performance, a mixture ratio of 4:1 is chosen. The lower mixture ratio increases the relative flow through the pump, shifting the operating point to the right of the zero H-Q line slope and returning stability to the flow. The zero slope is used as a guide. More insight into the stability condition can be obtained with a transient model of the system that includes the coolant jacket resistance. With this model an assessment of the nature of the instability (bounded or diverging) can be made.

Figure 7.

PREDICTED FUEL PUMP PERFORMANCE FOR 7500 LB ENGINE

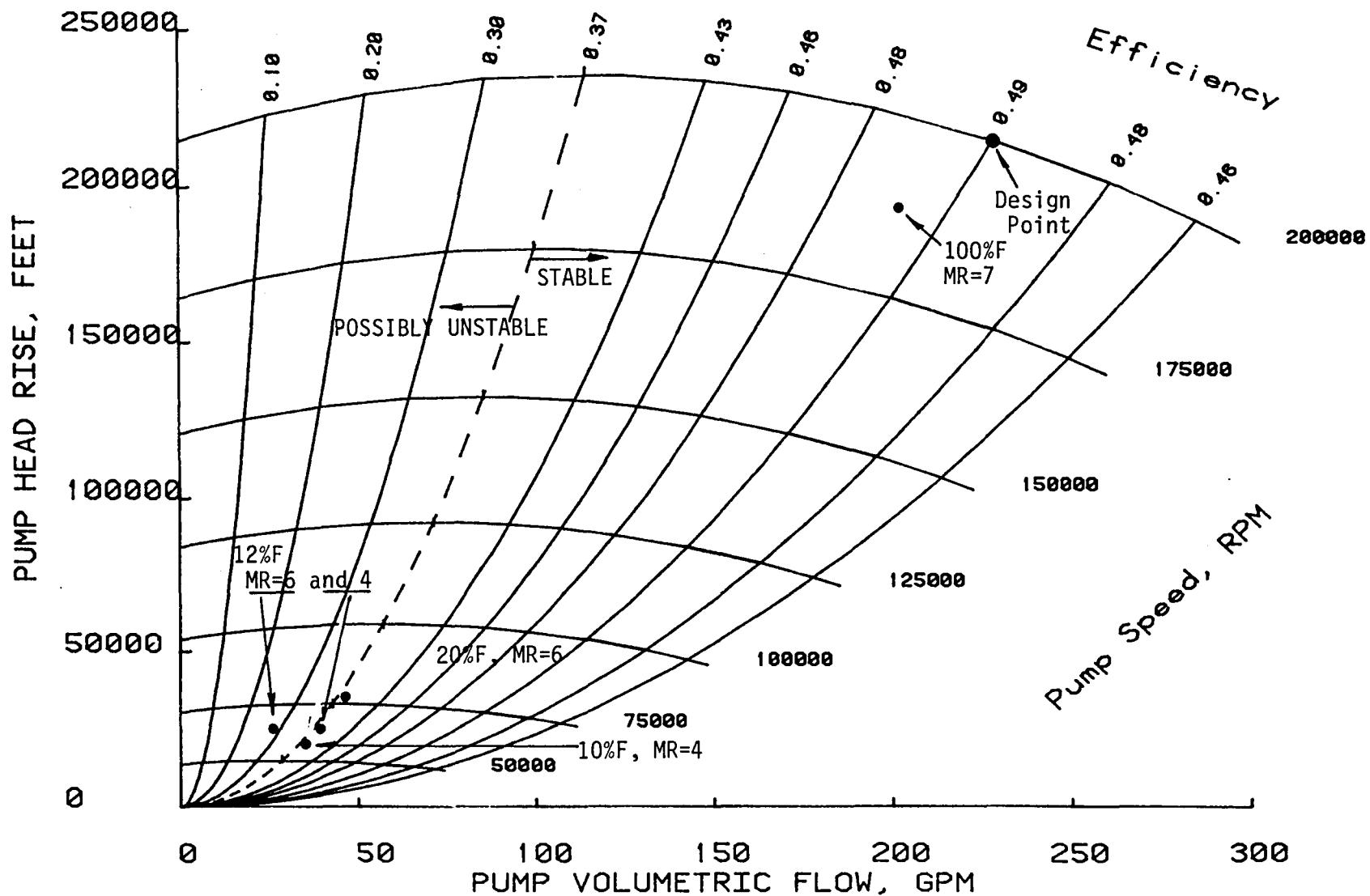

Table 16 presents a summary of important engine operating parameters at off-design conditions.

TABLE 16. 7.5K LB ENGINE BALANCE SUMMARY AT OFF-DESIGN
THRUSTS AND MIXTURE RATIOS

	THRUST, % OF NOMINAL			
	DESIGN POINT	100	20	12
ENGINE MIXTURE RATIO	6	7	6	4
CHAMBER PRESSURE, PSIA	1576	1536	321	205
ENGINE SPECIFIC IMPULSE, SEC	488.86	482.9	476.36	481.17
ENGINE THRUST, LB	7500	7500	1500	900
COMBUSTOR HEAT LOAD, BUT/SEC	6440	6060	1727	1224
NOZZLE HEAT LOAD, BTU/SEC	1416	1325	358	260
T/C FUEL FLOWRATE, LB/SEC	13.14	1.917	.445	.369
T/C OXID. FLOWRATE, LB/SEC	2.15	13.571	2.01	1.494
FUEL PUMP SPEED, RPM	199661	187736	77653	65799
FUEL PUMP EFFICIENCY, %	48.98	48.81	38.07	37.56
FUEL PUMP HORSEPOWER	1525	1234	74	45
FUEL PUMP DISCHARGE PRESSURE, PSIA	6559	5928	1098	795
OXID PUMP SPEED, RPM	66463	63503	23529	20036
OXID PUMP EFFICIENCY, %	62.03	61.63	52.26	40.2
OXID PUMP HORSEPOWER	1915	188	7.4	4.0
OXID PUMP DISCHARGE PRESSURE, PSIA	2705	2394	384	283
FUEL TURBINE INLET TEMP, °R	1129	1186	1354	1156
FUEL TURBINE FLOWRATE, LB/SEC	1.932	1.648	.204	.155
FUEL TURBINE PRESSURE RATIO	2.23	2.08	1.61	1.60
FUEL TURBINE EFFICIENCY	64.1	63.4	42.7	40.1
OXID TURBINE INLET TEMP, °R	989	1051	1282	1098
OXID TURBINE FLOWRATE, LB/SEC	1.462	1.359	.161	.117
OXID TURBINE PRESSURE RATIO	1.118	1.118	1.07	1.07
OXID TURBINE EFFICIENCY	57.6	55.8	35.2	34.2

FAILURE MODE EFFECTS AND RELIABILITY ANALYSES REVIEW

FMEA AND RELIABILITY ANALYSES

Upon completion of the baseline engine definition, a failure mode and effects analyses and reliability analyses were conducted under the ICHM subtask E.1. Review of these analyses and their application in FME mitigation and reliability improvement were one of the major efforts completed during the Phase I study. The relation of this review to the overall study can be seen in the logic diagram previously presented in Figure 1. Results of this effort were incorporated into the development of advanced engine concepts and ultimately into the updated engine design. An overview of the approach taken in this review and its application is presented in Figure 8.

The scope of the FMEA was defined as encompassing the major engine components which include the injector, combustor, fixed regenerative cooled and retracable radiation cooled nozzle, and the nozzle retraction mechanism itself. In addition, several major engine systems were considered. The heat transfer systems included the chamber coolant circuits, LOX heat exchanger and the hydrogen regenerator. Components of the turbine drive systems covered were the low and high pressure fuel and oxidizer turbines and the associated bypass and shutoff valving. Propellant feed systems analyzed included the low and high pressure fuel and oxidizer pumps and the inlet and main propellant valves. Operational modes addressed in the FMEA and reliability analysis were tank-head idle, pumped idle, mainstage, and transitions during start and shutdown. Within this scope, the FMEA identified 112 separate modes of failure and their effects on engine operation. Causes of each of the failures were explained, means of detection defined, and the adequacy of response time evaluated. Finally, each failure mode was assigned a criticality number based on the severity of its impact upon operational capability.

FAILURE MODE EFFECTS AND RELIABILITY ANALYSIS REVIEW AND APPLICATION

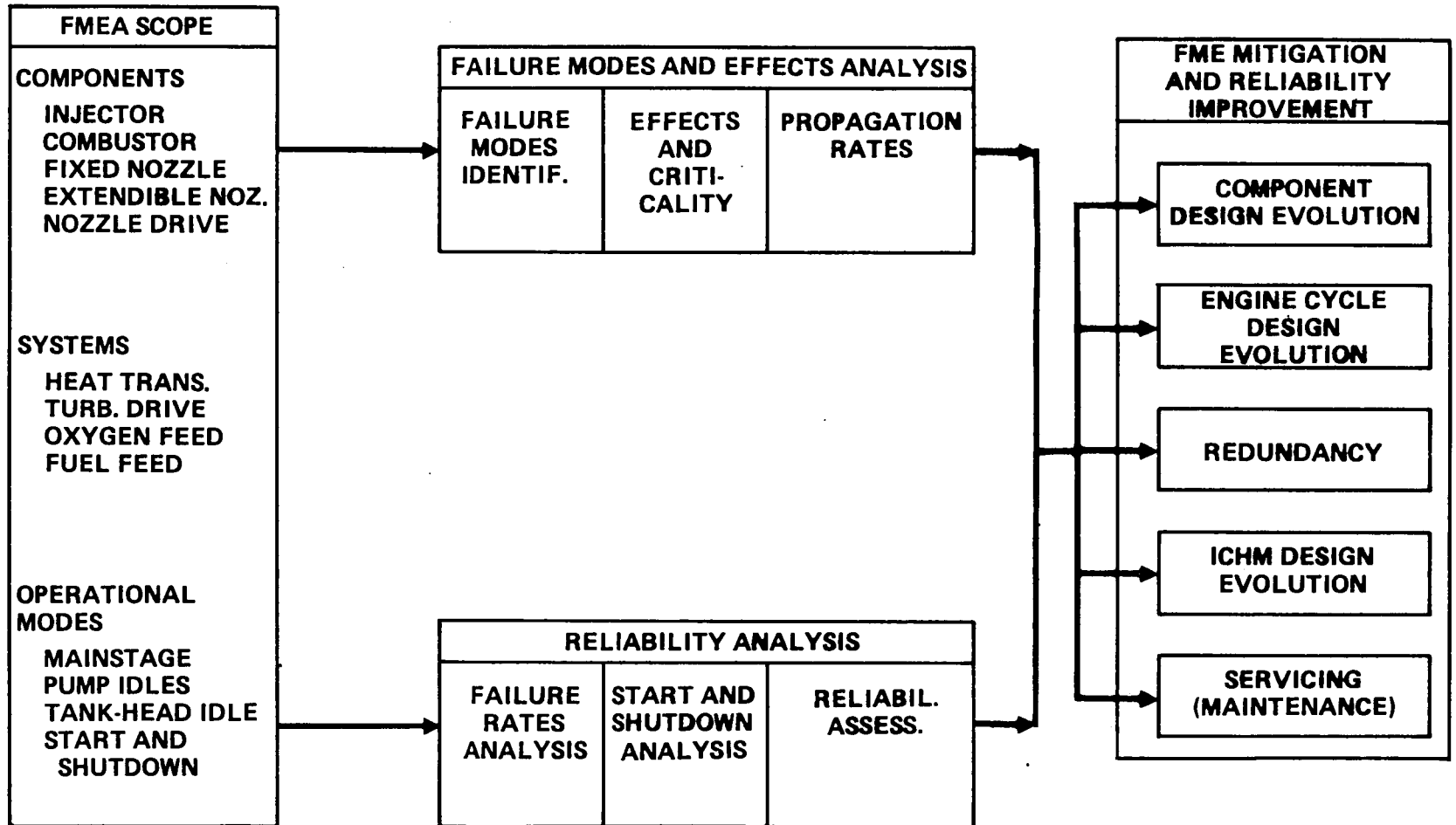

RI/RD86-116

40

491-119



FIGURE 8.

A sample of the detailed output provided by the FMEA is presented in Appendix 5. A summary of the FMEA is provided in Table 17, in which the number of failure modes for each component in each criticality rating is tabulated. The criticality numbers are defined as follows:

CRITICALITY NO.	ENGINE EFFECT	VEHICLE EFFECT	MISSION EFFECT
1	Major uncontained damage to an engine subsystem or component resulting in widespread engine damage.	Significant damage to adjacent equipment and/or vehicle probable.	Mission abort ⁽¹⁾ low probability of vehicle loss, crew death or injury.
2	Significant contained damage to a vital engine subsystem or component sufficient to render it inoperative or its continued operation hazardous	Damage to adjacent equipment or vehicle highly improbable.	Mission abort ⁽¹⁾
3	Performance Degradation or notable damage to component/subsystem. Continued operation conditionally acceptable.	None	Mission abort ⁽¹⁾ conditionally dependent.
4	Minor failures fully tolerated by continued operation at an acceptable hazard level. Minor propellant leakage from flanged joints.	None	Delay until resolved at mission start.
5	Nuisance failures.	None	Correct at next routine maintenance.

(1) Mission abort for criticality 1 through 3 failures applies only on outboard phases prior to OTV payload disposition. After abort, emphasis is placed on safe return of the vehicle/crew regardless of payload disposition.

TABLE 17.

OTV ENGINE CRITICALITY SUMMARY

SYSTEM	NO. OF MODES	NO. OF CRIT. 1	NO. OF CRIT. 2	NO. OF CRIT. 3	NO. OF CRIT. 4	NO. OF CRIT. 5
ENGINE SYSTEMS	5	3	1	1		
THRUST CHAMBER						
INJECTOR	5	1	1	3		
CHAMBER	3	2			1	
FIXED NOZZLE	3	1		1	1	
EXTEND. NOZZLE	1		1			
NOZ. DRIVE	2			1	1	
HEAT TRANSFER SYS.						
CHAMBER COOL.	2	2				
LOX HEX	3	1		2		
REGEN	3			1	2	
TURBINE DRIVE SYS.						
LPFT	5		4	1		
HPFT	5	3	1	1		
HPOT	6	4	1	1		
HPOT-LPOT	6	4	1	1		
TBV	3		2	1		
OTBV	3		2	1		
TSV	7			6	1	
OXYGEN FEED SYS.						
INLET VALVE	7	1	2		4	
LPOP	7	1	5	1		
HPOP	7	5	1	1		
MOV	2	1			1	
FUEL FEED SYS.						
INLET VALVE	7		2	4	1	
LPFP	6		5	1		
HPFP	6	4	1	1		
MFV	8		4	4		
TOTAL	112	33	34	33	12	0

RI/RD86-116

42

491-120

In the reliability analysis which was done in conjunction with the FMEA, single start reliabilities and failure rates for major engine components were determined. In that analysis, the engine was broken down into six components. These subsystems were: combustion devices, turbomachinery, controls/valves, electrical/flight instrumentation, controller, and the systems, line, and ducts. Failure apportionment, as defined as percentage of failures for the respective component during a 12 minute burn, were calculated. From that information, an overall baseline engine start reliability and failure rate were estimated.

Review of the FMEA and reliability analyses provided important direction and information required in the subsequent FME mitigation and reliability improvement studies. By addressing problem areas flagged out in this review, the baseline engine will evolve into a more reliable and serviceable engine in an efficient manner.

FME MITIGATION AND RELIABILITY IMPROVEMENT

Approach

Results of the FMEA and reliability analysis review were then used in FME mitigation and reliability improvement studies. In that effort, methods of improving engine reliability and mitigating failures were evaluated. Approaches considered included component design evolution, engine cycle design evolution, redundant components, ICHM design evolution, and servicing/maintenance scenerios.

These methods for improvement are summarized in Table 18, and will be addressed individually in the following sections. Each category in itself has several approaches which were investigated.

FME MITIGATION AND RELIABILITY IMPROVEMENT

COMPONENT DESIGN EVOLUTION

- VALVES ACTUATION
 - TYPES
 - MARGINS
- TURBOMACHINERY

ENGINE AND CYCLE DESIGN EVOLUTION

- DERATED ENGINE
- MODULAR PACKAGING
- THRUST AND MR CONTROL DURING TRANSIENT
- EMERGENCY SHUTDOWN (TSV)

REDUNDANCY

- SENSORS
- HIGH PRESSURE TURBOMACHINERY
- ELECTRICAL HARNESSSES

ICHM EVOLUTION

- ADVANCED SENSOR SPECIFICATIONS
- CONTROLLER DESIGN AND LOGIC
- CONTROLLER LOCATION

SERVICING

- REMOVAL AND REPLACEMENT
- PACKAGING FOR MAINTAINABILITY
- CHECKOUTS (AUTOMATION AND TELEPRESENCE)

44
RI/RD86-116

491-122



Rockwell
International
Rocketdyne Division

Examples of failure mitigations through the engine and ICHM design are presented in Table 19. As can be seen, failure mode effects have been reduced in criticality or eliminated entirely by design modifications. The ICHM modification failure mode criticality designations are as follows:

CRITICALITY NO.	ENGINE EFFECT	VEHICLE EFFECT	MISSION EFFECT
A	Safe shutdown of engine before uncontained damage results.	None	Mission abort(1)
B	Safe shutdown of engine before significant contained damage results.	None	Mission abort(1)
C	Reduced power level operation.	None	Mission abort(1)
D	Parallel or standby redundant system assumes function - normal engine operation continues.	None	Delay until resolved at mission start.

Component Design Evolution

Two approaches were addressed for FME mitigation and reliability improvement through component design evolution. These included improvements in the reliability of valve actuation and turbomachinery operation. The primary failure mode of the electric actuated valves to be used in the QTV engine is contamination-induced stalling of the drive actuators. Potential solutions realized through design modifications are to increase motor force margins in order to overcome friction, provide better contamination control and to reduce contamination sensitivity of the mechanism. The most probable failure mode of the inlet fuel and oxidizer valves is the failure of the pneumatic actuator thus preventing the opening of the valve. A potential design solution relies upon the use of electric or squib backup actuators. A summary of these valve related improvements is presented in Table 20.

TABLE 19.

FAILURE MITIGATION THROUGH ENGINE AND ICHM DESIGN

FMEA			FAILURE MITIATION APPROACHES					NEW CRIT. NO.	
REF. NO.	FAILURE MODE	CRIT. NO.	DESIGN		ICHM		SERVICING		REDUNDANCY
			COMPONENT	ENGINE AND CYCLE	SENSORS	CONTROL			
0101	LPFT OR HPOT DAMAGE VIA DEBRIS FROM HPFT FAILURE	1		ADD DEBRIS CATCHER DOWN- STREAM OF HPFT					3/C
0102	LPFT OR HPOT DAMAGE VIA DEBRIS FROM HPFT FAILURE	1/A				PREDICT LIFE REMAINING FROM DEFLECTO- METER AND ISOTOPE MONITORS			4/C
0103	TRANSIENT M.R. EXCURSIONS ERODE LOX POST TIPS	3			ISOTOPE DETECTOR NOTES EROSION				4
0104	NORMALLY OPEN GOV CAUSES LOX RICH START	2	USE SOLENOID ACTUATED GOV						FAIL- URE MODE OBTI- ATED
0105	EMERGENCY SHUTDOWN CONSTRAINED BY VALVING OPTIONS	1	ADD PNEUMATIC OVERRIDE TO GOV AND MFV	ADD TURBINE SHUTOFF VALVE					2/A 2/A

46
 RI/RD86-116

491-121



Rockwell
International
Rocketdyne Division

TABLE 20.

FAILURE MODE MITIGATION AND RELIABILITY IMPROVEMENT VALVE ACTUATOR DESIGN

- **ELECTRIC VALVES (MFV, TBV, OTBV, TSV, MOV, GOV)**
 - FAILURE MODE: CONTAMINATION-INDUCED STALLING OF DRIVE ACTUATOR
 - POTENTIAL SOLUTIONS: INCREASE MOTOR FORCE MARGINS TO OVERCOME FRICTION
 - BETTER CONTAMINATION CONTROL
 - REDUCE CONTAMINATION SENSITIVITY OF MECHANISM

- **INLET VALVES (IFV, IOV)**
 - FAILURE MODE: FAILURE OF PNEUMATIC ACTUATOR PREVENTS VALVE OPENING
 - POTENTIAL SOLUTION: USE BACKUP ACTUATORS (e.g., SQUIBB OR ELECTRIC)

Overall turbomachinery reliability can be enhanced by improvements in each turbopump design. The low pressure turbopumps have a high reliability and do not require improvements. Several design improvements in the high pressure turbopumps though, would increase reliability. Refinements in interpropellant seal design would reduce the risk of interpropellant mixing. Critical speed and wear problems could be alleviated through improvements in shaft and bearing designs. In addition, improved materials and fabrication techniques would enhance the strength of the turbopump components.

Another method of increasing turbopump reliability is to provide redundant systems for backups. These could be in the form of boost pumps for failed main pumps or complete spare turbomachinery sets capable of being "valved in" upon failure of the primary units. This approach is covered more thoroughly in the latter section on FME mitigation and reliability improvement through redundancy. A summary of the methods to improve turbomachinery reliability is provide in Table 21.

Engine and Cycle Design Evolution

Derated Engine. FME mitigation and improvements in reliability are achievable through engine and cycle design evolution in several areas. One approach investigated was the use of two derated 15K engines in the OTV missions scenario for a total thrust of 15,000 lbs. Advantages and disadvantages were referenced to two 7.5K engines. Impacts assessed included: low cycle fatigue life, performance, weight payload, and DDT&E cost. Overall engine reliability and life cycle costs would need to be determined before results of the assessment could be finalized.

Low cycle Fatigue (LCF) Life. Down thrusting of a 15K engine to 7500 lb thrust increases engine life by decreasing LCF in the combustor. Although coolant bulk temperatures increase, the temperature gradient across the hot wall decreases. In this manner, the thermal strains are reduced and combustor life increases. Trends of LCF with off-design thrust operation are presented in Figure 9. The four cases considered are shown in the table on that

TABLE 21.

IMPROVING TURBOMACHINERY RELIABILITY

- **IMPROVE EACH TURBOPUMP DESIGN**
 - LOW PRESSURE TURBOPUMP MOST RELIABLE
 - HIGH PRESSURE TURBOPUMPS IMPROVEMENTS
 - INTERPROPELLANT SEAL DESIGN
 - SOFT SEALS
 - SHAFT AND BEARING DESIGNS TO ALLEVIATE CRITICAL SPEED AND WEAR PROBLEMS
 - IMPROVED MATERIALS AND FABRICATION FOR STRENGTH ENHANCEMENT

- **PROVIDE FUNCTION REDUNDANCY**
 - BOOST PUMPS FOR FAILED MAIN PUMPS
 - SPARE TURBOMACHINERY SETS

RI/RD86-116

49

491-124



Rockwell
International
Rocketdyne Division

OFF-DESIGN LIFETIME TRENDS THRUST CHAMBER

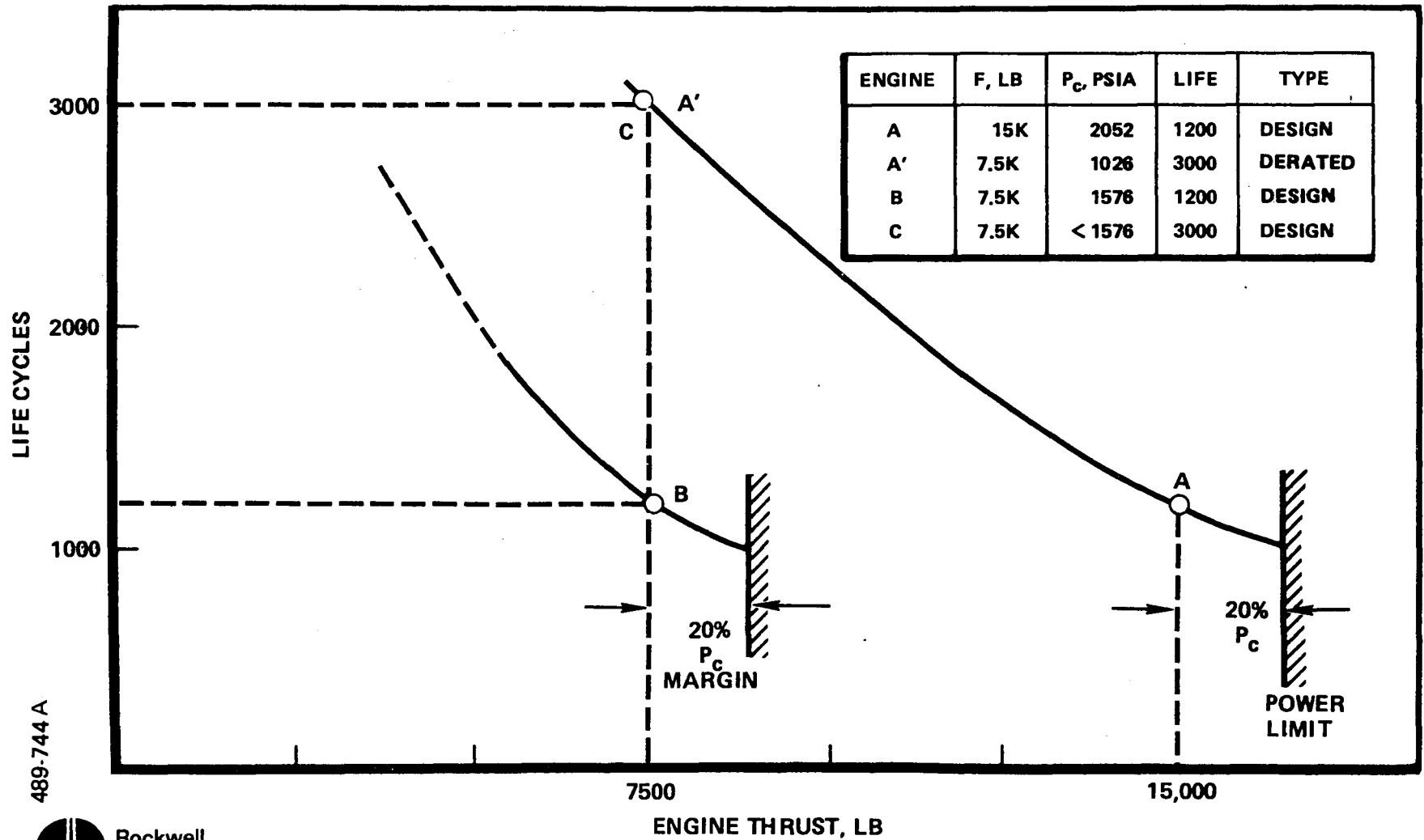

RI/RD86-116
50

489-744 A



FIGURE 9.

figure. Both the 15K and 7.5K engines are designed for 300 cycle lives with a safety factor of four ($300 \times 4 = 1200$). At the time of the derated engine study, the effect of soft-wear ring seals had not been investigated, consequently the reference 7.5K engine did not incorporate them and had a chamber pressure of only 1576. Up-thrusting of engines can be performed up to 120% of design thrust where a power limit is reached. The throttled engine (A') is modified (kitted) in the injector and turbopump components, respectively, to improve combustion efficiency and to avoid critical speed problems.

By derating the 15K engine down to 7.5K, the thrust chamber life increases from 1200 cycles to 3000.

Performance, Weight, Payload, and Cost. Other impacts of off design, derated operation are presented in Table 22 for the four cases.

Derating of the 15K engine increases the turbopump life from 1200 cycles up to 4800. Although turbopump life has the largest increase with throttling, engine life is determined by the combustor which has the shortest life. The throttled 15K engine (A', in Figure 9) has a life 2.5 times higher than the reference 7.5K engine design. To achieve the higher life the 7.5K engine design (c) would require higher coolant velocities and pressure drops and would pay a penalty on chamber pressure and thus in performance and engine weight. The throttling impacts on performance and weight are reflected in the payload changes for these engines, including the original 15K (A engine) as shown in Table 22. The throttled engines (A') deliver 634 lb less payload than the reference engine (B). For a reference, a manned sortie mission has been used with 14,000 lb delivered to GEO and returned. The redesigned 7.5K engines deliver performance somewhat short of the reference engines. The payload loss for that case is estimated to be 0-to-634 lbs.

A summary of this study is shown in Table 23. The 7.5K reference engines have a payload, development cost and unit cost advantage. The derated 15K engines have the growth potential advantage which could accommodate higher payloads as

TABLE 22.

OFF-DESIGN LIFETIME IMPACTS ON OTV ENGINES

ENGINE DESIGNS ⁽¹⁾	A	REF. B	C	A'
OPERATING THRUST, (F)/ENGINE KLB	15	7.5	7.5	7.5
LIFE T/C	1200	1200	3000	3000
LIFE T/P	1200	1200	4800	4800
OPERATING F (NOMINAL THRUST) %	100	100	100	50
ΔPERFORMANCE, SEC	2	0	0 TO -4	-4
CHAMBER PRESSURE, PSIA	2052	1576	≤1576	1026
WEIGHT/ENGINE, LB	395	240	>240	395
2-ENGINE WEIGHT, LB	790	480	>480	790
THRUST GROWTH CAPABILITY/ENG.	20%	20%	20%	120%
ΔDDT&E COST (\$M, 1984)	30	REF.	20	50 ⁽⁵⁾
ΔPROD. COST (\$M, 1984) ⁽²⁾	12	REF.	3	14
ΔPAYLOAD, LB ⁽⁴⁾	92 ⁽³⁾	0	0 TO -634	-634

A = 15,000 LB ENGINE POINT DESIGN, LIFE = 1200 CYCLES

A' = DERATED 15,000 LBL ENGINE, KITTED INJECTOR & TURBOPUMP (LIFE = 3000 CYCLES)

B = 7500 LB ENGINE POINT DESIGN, LIFE = 1200 CYCLES

C = 7500 LB ENGINE POINT DESIGN, LIFE = 3000 CYCLES

(1) ALL ENGINES: 6 = 1200, %L = 90

(2) 20 ENGINES

(3) 247 LB W/ONE 15K ENGINE

(4) MANNED SORTIE MISSION - 14,000 LB

(5) BASED ON DEVELOPING FULL THRUST ENGINE FIRST

489-743



Rockwell
International
Rocketdyne Division

ASR84-76
11-30-84

TABLE 23.

COMPARISON OF 7.5K AND DERATED 15K ENGINES

● CONDITIONS

- BOTH ENGINES OPERATE NOMINALLY AT 7.5K
- TWO ENGINES/VEHICLE
- 750 CYCLE OPERATING LIFE AT 7.5K
- $\epsilon = 1200$; % L = 90

● 7.5K ENGINE ADVANTAGES

- 634-LB PAYLOAD GAIN (4.5%) DUE TO LOWER WEIGHT AND HIGHER I_s
- 50M LOWER DEVELOPMENT COST⁽¹⁾
- 0.7\$M (20%) LOWER UNIT COST

● 15K ENGINE ADVANTAGES

- 120% THRUST GROWTH POTENTIAL (vs 20%)
 - HIGHER PAYLOADS
 - FEWER PERIGEE BURNS
 - MORE ENERGETIC MISSIONS
 - HIGHER ORBITS
 - FAST RESCUE MISSIONS
 - ALTERNATE ORBIT PLANES
- ENGINE-OUT MISSION SUCCESS CAPABILITY

(1) BASED ON DEVELOPING FULL THRUST ENGINE FIRST

RI/RD-86-116
53

489-745



Rockwell
International
Rocketdyne Division

the NASA mission model evolves to include larger vehicles. Fewer perigee burns and more energetic missions are also capable. With the longer lives expected for the critical components, the derated engines would be inherently more reliable. Life cycle cost assessments may yield additional benefits for the derated 15K engines.

Modular Packaging. Another approach in which FME mitigation and improvements in reliability are achievable through engine design evolution is in modular engine packaging. Results of the FMEA indicate that a large portion of the failure modes are associated with the propellant turbomachinery and valves. This can be seen in Table 24 in which the components susceptible to failures were grouped into modules and the number of failure modes, weighted by criticality, were summed. The engine was broken down into five separate modules. The fuel and oxidizer modules each contained the respective propellant valving and turbomachinery. The core module was primarily comprised of the combustor, the fixed portion of the nozzle and the igniter/injector. The two remaining modules were the retractable nozzle and the control system. A percent contribution to the weighted sum of the failure modes was determined for each module. The failure modes for the controller and sensors have not yet been evaluated and therefore, the control system module was not included in the analysis. As can be seen, the fuel and oxidizer modules account for large portions of the sum of weighted failure modes with 40.6% and 36.1%, respectively. By adopting an engine design in which the components are physically grouped into the modules presented above, engine repairs could be simplified by module replacement as opposed to the tedious disassembly and replacement of individual failed components. An engine layout incorporating this concept is presented in Figure 10. Modular engine packaging is covered in more detail in the subsequent section on Engine Designs.

Thrust and MR Control During Transient

As part of the effort in FME mitigation and reliability improvement through engine and cycle design evolution, a transient simulation model was developed for the baseline engine. This model was designed to aid in the evaluation

TABLE 24.

MODULAR ENGINE DESIGN-FM BREAKDOWNS

MODULES	COMPONENTS	MODES TIMES CRITICALITY	% (FM X CRITICALITY)
FUEL	INLET VALVE LPFTP HPFTP MFV TBV TSV	TOTAL 172 22 42 49 28 11 20	40.6
OXIDIZER	INLET VALVE LPOTP HPOTP HPOTP MOV OTBV	TOTAL 153 21 21 55 59 7 11	36.1
CORE	COMBUSTOR FIXED NOZZLE IGNITER/INJECTOR HEAT EXCHANGER GOX VALVE SYSTEMS	TOTAL 90 22 10 18 11 4 18	21.2
NOZZLE	RADIATION COOLED NOZZLE EXTENSION MECHANISM	TOTAL 9 4 5	2.1
CONTROL SYSTEM	CONTROLLER SENSORS	TBD TBD	TBD TBD

RI/RD86-116

55

491-127



Rockwell
International
Rocketdyne Division

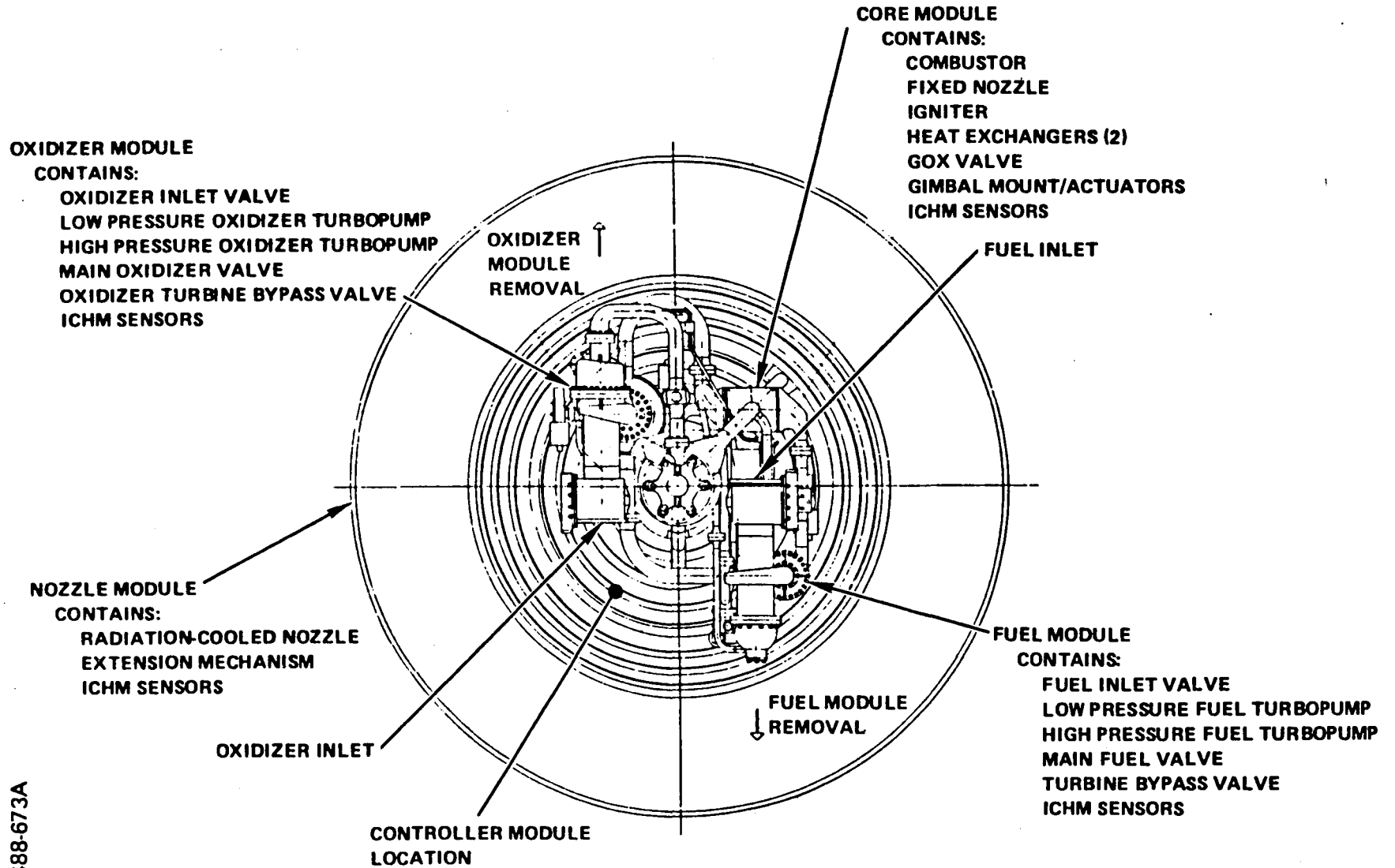

488-673A

FIGURE 10. MODULAR ENGINE, TOP VIEW

of engine start and shutdown characteristics, engine throttling capabilities, and component transient sensitivities including opened-loop control valve sequencing, closed-loop valve controller gain, and valve placements.

Several engine transient simulation runs were made for the baseline 7.5K engine in order to determine proper valve sequencing for stable engine operation and to predict engine dynamic characteristics during start and shutdown. Results indicated that:

1. The engine can be ramped from Tank Head Idle (THI) (engine conditioning and propellant tank settling completed) to Pumped-Idle (PI) mode in approximately 6 seconds without extreme mixture ratio overshoots. The engine operates stably during the transition to PI mode (12 percent of full thrust and 4:1 mixture ratio) and at steady state PI.
2. The engine can be ramped stably from PI mode to 90 percent of full thrust within 5 seconds. Stable engine operation is also achieved at mainstage (*7,500 lb thrust and 6:1 mixture ratio).
3. The engine can be shutdown stably in approximately 0.2 seconds from full thrust. The main fuel and oxidizer pump speeds, however, require 3 seconds to decay due to the inertia of the rotating components.

Table 25 summarizes the time requirements for the 7.5K engine start and shutdown. In the open-loop control valve sequencing employed for transition from THI to mainstage operation, the MOV opens to its PI position in 4 seconds while the MFV and TBV are left fully opened in the THI. Different MOV ramp rates were examined in order to obtain desired mixture ratio variations. Stable PI engine operation at 12 percent full thrust and 4:1 mixture ratio was achieved within 6 seconds from THI. A steady-state mixture ratio of 4:1 was selected for PI in order to avoid flow and instability induced by the low main fuel pump flow coefficients.

TABLE 25. 7.5K ENGINE STARTS AND SHUTDOWN TIME CAPABILITIES

ENGINE OPERATION	TIME REQUIREMENTS (SECONDS)
<u>ENGINE RAMP THI TO PI:</u>	
CHAMBER PRESSURE	6.0
THRUST	6.0
MIXTURE RATIO	6.0
<u>ENGINE RAMP PI TO 90% RATED THRUST:</u>	
CHAMBER PRESSURE	5.0
THRUST	5.0
MIXTURE RATIO	5.0
<u>ENGINE SHUTDOWN FROM RATED THRUST:</u>	
CHAMBER PRESSURE	0.2
THRUST	0.2
MIXTURE RATIO	0.2
MAIN PUMP SPEEDS	3.0

Details of this study including valve sequencing and engine parameters such as chamber pressure, thrust, mixture ratio and pump speeds are presented in Appendix 5. This transient simulation model has subsequently been modified to include the near term controller for closed-loop control simulation. This additional effort was done under the ICHM subtask E.1/E.2.

Turbine Shutoff Valve. As part of the engine design evolution, the effects of a turbine shutoff valve were determined. The primary function of the turbine shutoff valve (TSV) is to provide rapid turbine flow cutoff for quicker turbomachinery speed decay during engine shutdown to limit the time of operation at the fuel turbopump critical speeds. The TSV may also be necessary to prevent rotation of the turbomachinery during the tank-head idle mode of operation. The two locations being considered for the TSV are shown on the OTV engine schematic presented in Figure 11. The TSV can be located either downstream of the high pressure oxidizer turbine (HPOT) or upstream of the high pressure fuel turbine (HPFT) as indicated on the schematic at locations 8-a and 8-b, respectively.

The engine transient simulation model described in the previous section was modified to include a TSV. Several engine shutdown transient simulations from mainstage operation were then made. Results from the model indicate that chamber pressure, thrust, and mixture ratio are cutoff stably within 0.2 seconds from full thrust for the engine with a TSV. The main pump speeds decay to 10 percent of the nominal values within 2 seconds. This same engine without a TSV requires more than 3 seconds for the same reduction in pump speeds. Location of the TSV had little effect on the transient shutdown trends in chamber pressure, thrust, mixture ratio, or pump speed decay.

Details of this study are presented in Appendix 6 in which valve sequencing and pertinent engine parameters are illustrated for both locations of the TSV. The reduced time for pump speed decay could result in increased turbomachinery life and improved engine reliability.

Redundancy

FME mitigation and improvements in reliability are achievable through component redundancy in three areas. Redundant sensors for critical control and health monitoring parameters is one of these areas. Backup sensors not only provide fail operational capability during primary sensor failure, but also provide a means by which erroneous signals may be detected. The enhanced

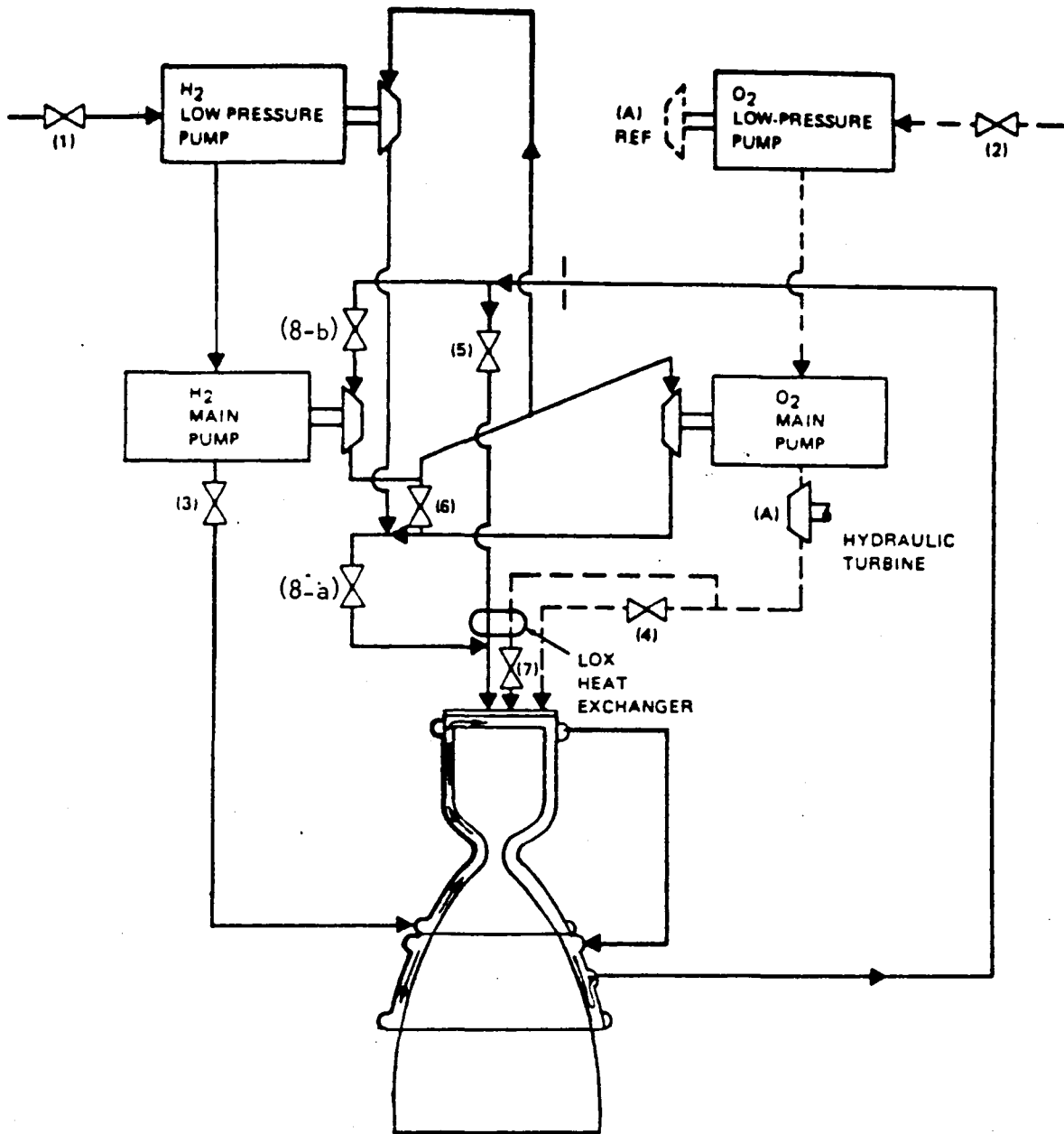

- (1) IFV - INLET FUEL VALVE
- (2) IOV - INLET OXIDIZER VALVE
- (3) MFV - MAIN FUEL VALVE
- (4) MOV - MAIN OXIDIZER VALVE
- (5) TBV - TURBINE BYPASS VALVE
- (6) OTBV - OXIDIZER TURBINE BYPASS VALVE
- (7) GOV - GASEOUS OXIDIZER VALVE
- (8) TSV - TURBINE SHUTOFF VALVE
(LOCATED AT EITHER A OR B)
- (A) FULL FLOW HYDRAULIC TURBINE
FOR LOW PRESSURE LOX PUMP

Figure 11. OTV 7.5K Engine Flow Schematic with Turbine Shutoff Valve

sensing capability realized in this manner improves overall engine reliability and also assists in failure effects mitigation by enabling corrective measures to be taken based on accurate information.

These same benefits may be achieved through the use of redundant electrical/optical harnesses. Backup cables for critical sensor and control signals would be routed through different paths. In this manner, damage to one harness caused by a localized incident such as fire or impact would not affect the backup system, thus providing a fail operational result.

The high pressure turbomachinery is another area in which redundancy would improve engine reliability. A reliability and life cycle cost analysis was performed for various engine system configurations involving redundant components. The baseline case to which these systems were compared was a single 15,000 pound thrust engine without any redundant subsystems. The five configurations incorporating varying degrees of redundancy which were analyzed are:

- a) Single engine with boost and main pumps standby redundant;
- b) Single engine with standby redundant main pumps;
- c) Single engine with capability to switch out failed main pumps;
- d) Single engine with redundant power head (all components less thrust chamber); and
- e) Parallel redundant (2) main engines with a non-independent failure of 3 percent.

A schematic of configuration c with redundant high pressure turbopumps is presented in Figure 12.

In order to evaluate overall engine systems reliability, the failure rate apportionment between major component groups was determined. The estimating procedure was based, primarily, on actual data from the SSME but included other rocket engine data as well. These component reliabilities, failure rates, and apportionments are presented in Table 26.

REDUNDANT TURBOPUMP FUNCTIONS

- REDUNDANT LPTP AND HPTP
- ✓ REDUNDANT HPTP
- LPTP FOR FAILED HPTP

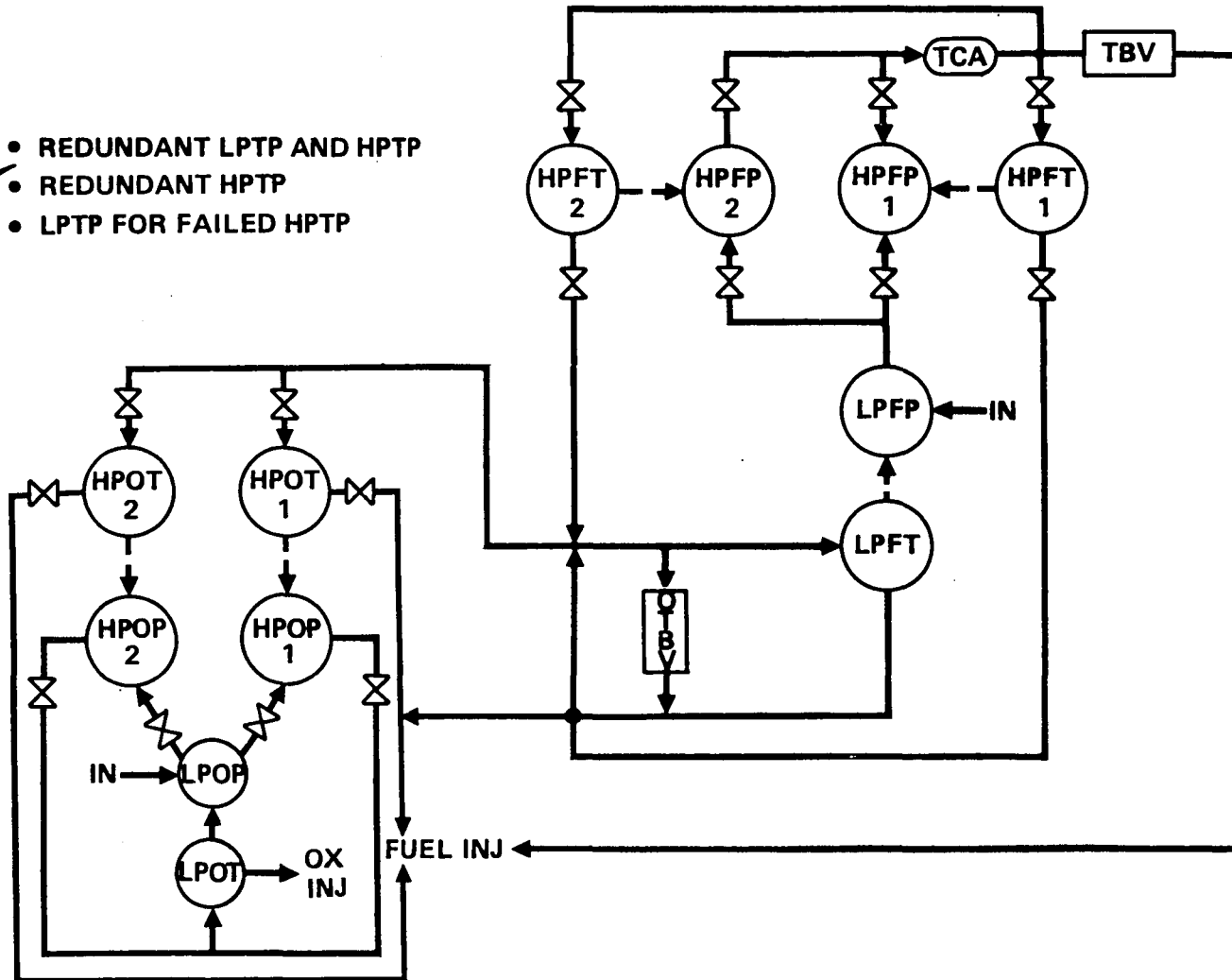

FIGURE 12.

62
RI/RD86-116

491-132

TABLE 26.

OTV ENGINE RELIABILITY DATA

COMPONENT	SINGLE START RELIABILITY $R_s^{(1)}$	FAILURE RATE, $\lambda^{(2)}$	APPORTIONMENT, % ⁽³⁾
SYSTEMS, LINES, DUCTS	0.999964	543	9.64
COMBUSTION DEVICES	0.99983	849	22.65
TURBOMACHINERY	0.99966	1666	44.87
CONTROLS/VALVES	0.999938	624	12.46
ELECTRICAL AND FLIGHT INSTRUMENTATION	0.999965	522	9.30
CONTROLLER	0.999997	66	1.08
	<u>0.999354</u>	<u>4270</u>	<u>100.00</u>

(1) $R_s = (R_s)^n$ FOR MULTIPLE BURNS

(2) FAILURE RATE FOR 10^6 HRS

(3) PERCENTAGE OF FAILURES FOR 12 MIN. BURN

RI/RD86-116

63

491-133



Rockwell
International
Rocketdyne Division

Overall engine system reliabilities and mean times to failure (MTTF) based upon the component data are summarized in Table 27. The parallel redundant configuration with two main engines achieves the highest reliability and MTTF, followed by a single engine with capability to switch out failed main pumps (operate on boost pumps only). Both configurations of standby pumps achieve modest increases in both reliability and MTTF. However, due to the added complexity, the configuration consisting of a single engine with a redundant power head achieves only a slight gain in reliability over the baseline engine.

These reliabilities were used to calculate the mission cost impact of the various engine configurations. The cost of engine/component redundancy is comprised of mission lost costs and the cost of the extra propellant required due to extra engine weight and reduction in I_{sp} . These calculations were based on 412 missions, a lost mission cost of 184 M\$, and a propellant cost of 1500 \$/lb. The life cycle costs for the various configurations are presented in Figure 13. The lowest overall cost is that of the baseline 15K single engine but the configuration with the lowest mission lost cost (also safest for return of manned vehicle) is the two 7.5K engine with only one required for mission completion.

ICHM Evolution

The ICHM system is an area which can contribute significantly to FME mitigation and reliability improvement. The key feature of the advanced ICHM which will make these benefits possible is the use of advanced sensors for engine health monitoring. By having a continuous monitor of failure prone components, incipient failures can be detected and corrective actions taken before serious damage might occur. Several of the sensors will also eliminate the need for routine inspections thus streamlining engine maintenance.

Fiberoptic deflectometers will be used to monitor the condition of ball bearings in the turbomachinery. By optically measuring the deformation of the outer race as each ball passes, bearing wear can be detected much earlier than

TABLE 27.

FUNCTION REDUNDANCY-ENGINE AND TURBOMACHINERY (MEAN TIME TO FAILURE AND RELIABILITY)

CONFIGURATION	MTTF = $\frac{1}{\lambda}$, HR. (2)	RELIABILITY (SINGLE MISSION)	FAILURES PER 10,000
SINGLE ENGINE – 15K (BASELINE)	233.3	0.99404	60
SINGLE ENGINE WITH T/P FUNCTION REDUNDANCY REDUNDANT LPP AND HPP PUMPS (8) REDUNDANT HPP PUMPS (6) BOOST PUMP FOR FAILED HPP REDUNDANT POWERHEAD	260.2 257.8 305.2	0.99464 0.99455 0.99513 0.99417	54 55 49
TWO-7500 LB ENGINES (3)	349.9 116.6	0.99987 (4) 0.99189 (5)	1.3 81

NOTES:

(1) $R = R_2^n e^{-\lambda t}$ (N = 6, t = 0.5 HR, λ = FAILURE RATE)

(2) $MTTF = \frac{10^6}{\lambda}$

(3) ONLY ONE ENGINE REQUIRED TO COMPLETE MISSION

(4) 0.03 NON-INDEPENDENT FAILURE CORRELATION FACTOR

(5) BOTH ENGINES NEEDED FOR MISSION

RI/RD86-116

491-134



Rockwell
International
Rocketdyne Division

REDUNDANCY, MISSION COST IMPACT

\$1500/LB. PROP., 412 MISSIONS*

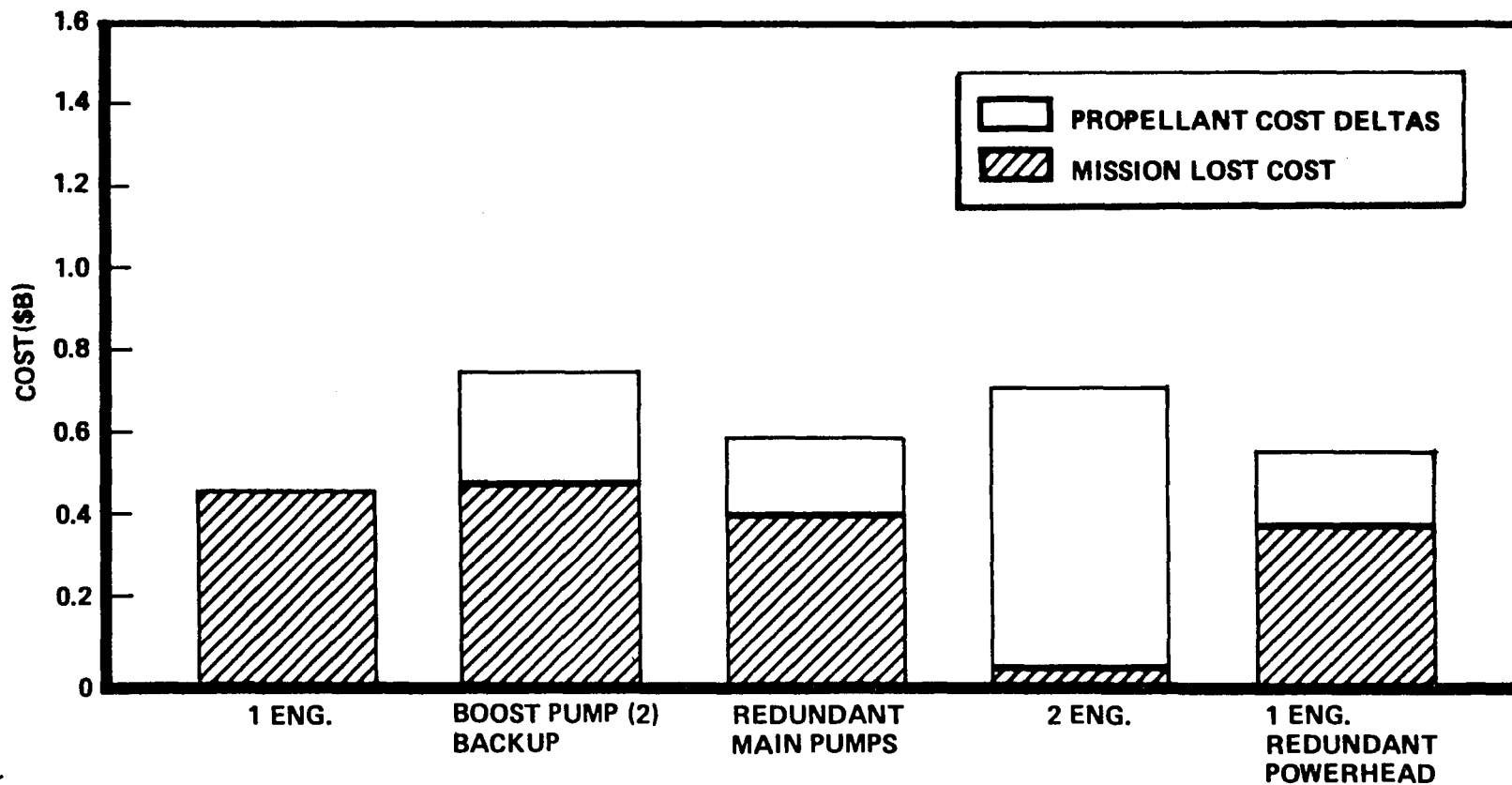

REDUNDANCY OPTIONS

- (1) 34 MANNED MISSIONS, MARTIN MARIETTA EXCHANGE FACTORS
- (2) EXTRA FUEL USED ONLY IN THE 34 MANNED MISSIONS

491-135A



Rockwell International
Rocketdyne Division

FIGURE 13.

RI/RD86-116
66

with accelerometers. This early detection provides a safety margin during which the controller can respond by engine throttling or shutdown. In this manner, major turbomachinery damage which could propagate to adjoining systems would be avoided. Use of fiberoptic deflectometers will also prevent false signals from spurious vibrations which would be picked up by accelerometers and would obviate routine visual inspections requiring disassembly.

Turbine blade condition may be monitored with fiberoptic pyrometers. By optically measuring the infra red radiation emanating from each blade, real time temperatures can be directly monitored. With their inherently fast response these sensors will be able to detect damaging over temps and excessive transient excursions quickly enough to allow corrective measures to be taken by the engine controller. In addition, fiberoptic pyrometers will eliminate the need for costly disassembly and visual inspection to assess turbine blade conditions.

Another advanced sensor to be included in the ICHM system is the isotope wear detector. In this approach the wear surfaces of critical components are doped with low level radioactive isotopes. As the surfaces wear the emissions are reduced. Thus, by externally monitoring the emissions with a Gieger-counter type sensor, the status of those components can be determined without disassembly and inspection. Hardware to be monitored by these sensors include ball bearings, valve seats, turbine blades, and the injector face. Isotopic wear detectors may be mounted on the engines for inflight sensing or more likely, used in preflight check outs in the space station bay.

Torquemeters will be used on turbopump shafts to detect bearing wear, seal rub, and blade/impeller to housing rub. The current method for detecting rub is done manually, postflight, with a hand held unit requiring the opening of access ports. By installing magnetic strips on the turbopump shafts, sensors can provide continuous real time measurements of the torques during engine operation. Early detection of rubbing and incipient turbopump failures will enable controller initiated responses to prevent further damage.

Similar sensors will be used to measure turbopump shaft speeds. Shafts will incorporate colored striping and optical tachometers for measurement. These sensors may help to prevent the over spinning of the turbopumps.

An additional advanced sensor being considered for the ICHM is a spectrometer for exhaust gas analyses. Engine mixture ratio may be determined from the chemical composition of the exhaust gas in addition to component wear/failure as evidenced by traces of metal species.

A summary of the advanced sensors to be used in ICHM systems is presented in Table 28. Their location can be identified on the engine schematic provided in Figure 14.

In order to take full advantage of the advanced sensors, the ICHM system must utilize a controller commensurate with their capabilities. It must have the memory capacity to store the additional sensory data and the computational ability to analyze and interpret that information. The logic programmed into the controller software will be a key element in FME mitigation and engine reliability improvement. Based on numerous input data from the advanced sensors, in addition to the standard instrumentation, the controller will continuously monitor the health of critical components while performing the normal functions of thrust and mixture ratio control. In the event of a failure or incipient failure as predicted through advanced sensor input analyses, the controller will direct corrective measures to prevent or minimize hardware damage. A few of the possible corrective actions would be a simple warning to the crew, off-design operation at reduced thrust level and/or mixture ratio, or a full engine shutdown. The decision as to what actions will be taken will be based not only on sensor data but mission status as well; i.e., the corrective actions taken during the early phases of a mission might be different from those taken after payload deployment during OTV return. Health monitoring data will also be used to determine when maintenance is required. Thus, the ICHM will allow an efficient maintenance plan based on servicing done on a "as needed" basis.

TABLE 28. ADVANCED ICHM SENSORS

ADVANCED TECHNOLOGY	MONITORED COMPONENTS	DESCRIPTION OF OPERATION	EXISTING MONITOR	BENEFITS OF ADVANCED MONITOR
FIBEROPTIC DEFLECTOMETER	BALL BEARING	BALL PASS FRFQ. AND AMPLITUDE MEASURED by DEFORMATION OF OUTER RACE AS EACH BALL PASSES	ACCELEROMETERS VISUAL INSPECTION	DIRECT MONITOR OF BEARING NO FALSE SIGNALS FROM SPURIOUS VIBRATION REAL TIME MONITOR NO DISASSEMBLY
FIBEROPTIC PYROMETER	TURBINE BLADES	IR RADIATION, ASSOCIATED TO TEMPERATURE, MEASURED FOR EACH BLADE	VISUAL INSPECTION GAS TEMPERATURE MONITOR	REAL TIME MONITOR NO DISASSEMBLY DIRECT MONITOR OF AFFECTED PART FAST RESPONSE NON-INTRUSIVE
ISOTOPE WEAR DETECTOR	BALL BEARINGS VALVE SEATS INJECTOR FACE TURBINE BLADES	WEAR SURFACE IS ISOTOPED AT VERY LOW LEVEL, SO AS IT WEARS, THE EMISSIONS ARE REDUCED	ACCELEROMETERS VISUALINSPECTION	NO FALSE SIGNALS FROM SPURIOUS VIBRATIONS POSSIBLE REAL TIME MONITOR DIRECT MONITORING OF MATERIAL LOSS
TORQUEMETER	TURBOPUMP ROTATING COMPONENTS	MAGNETIC STRIPES ON TURBOPUMP SHAFTS SENSOR MEASURES ROTATIONAL RESISTANCE	MANUAL MEASUREMENT	REAL TIME MONITOR NO DISASSEMBLY
OPTICAL TACHOMETER	TURBOPUMP SHAFTS	STRIPES ON SHAFT, OPTICAL SENSOR	VARIABLE RELUCTANCE MEASUREMENT	LESS COMPLEX
SPECTROMETER	EXHAUST GAS CHEMICAL COMPOSITION	SPECTROGRAPHIC SENSOR AND WAVE FORM ANALYZER FOR M.R. MEASUREMENT & METALLIC SPECIES	NONE	MEASURE M.R. AND METALLIC SPECIES FOR FAILURE DETECTION

MODULAR OTV ENGINE WITH ADVANCED INSTRUMENTATION SCHEMATIC

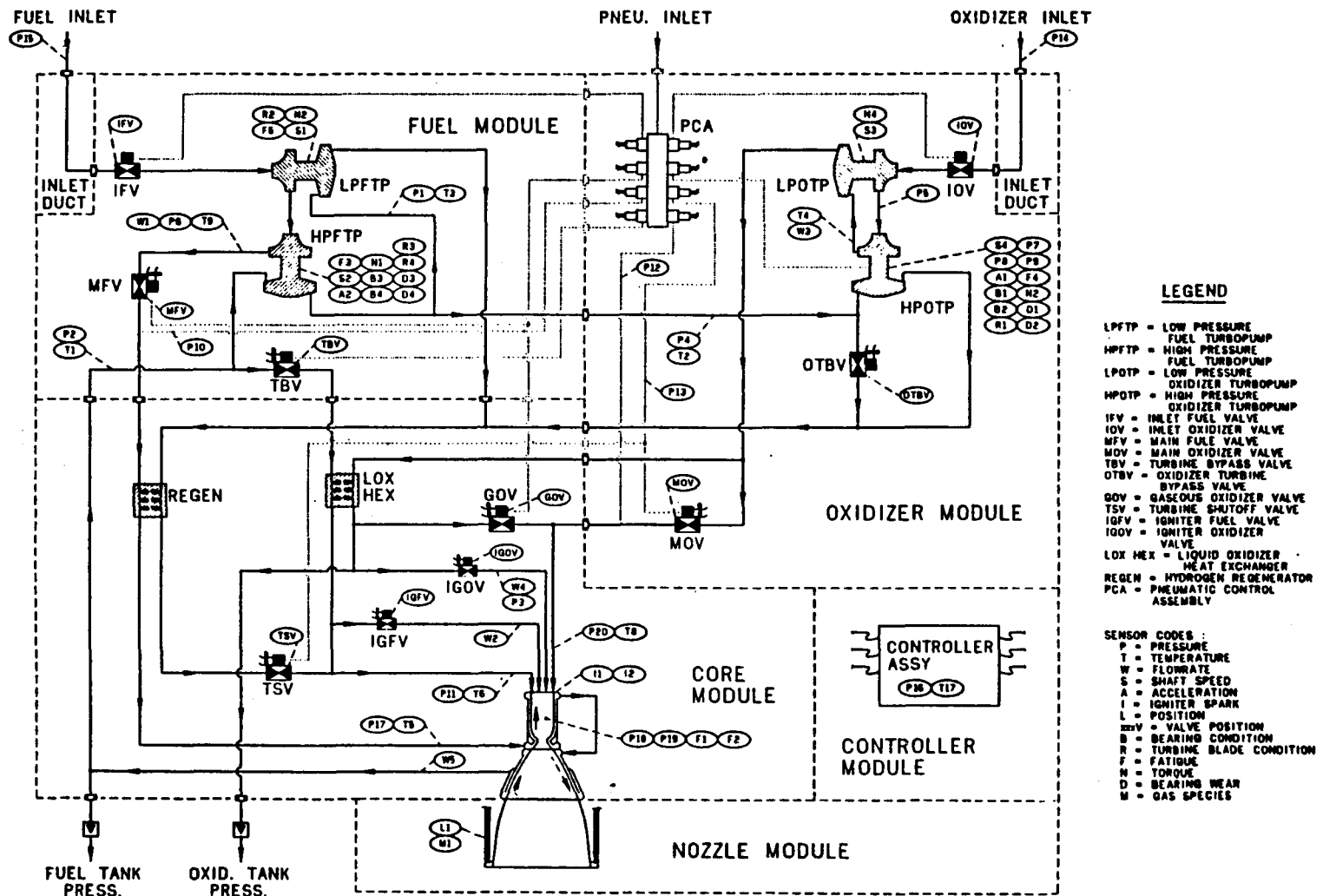

FIGURE 14.

RI/RD86-116

70

491-138

Servicing

Efforts completed in FME mitigation and reliability improvement through servicing will be covered in the following section under the heading of Maintainability Studies.

MAINTAINABILITY STUDIES & PLAN

The space-based operations and reusability goals for this engine will require novel and advanced maintenance techniques to be employed. To be truly effective, these servicing features must be incorporated at an early stage of engine development. Even though it is likely that this capability will not be utilized at initial deployment, consideration of space maintainability will permit smooth evolution to full space-based operations. One of the goals of the maintenance study was to determine the viability of engine space maintenance and configurations which maximize its overall benefit.

As currently envisioned, OTV servicing will be performed in a maintenance facility which is part of the Space Station. Although partially enclosed for debris protection, this facility will be a vacuum environment. Appropriate tools, parts storage, lighting, and spares will be contained in the servicing bay. Work will be performed by teleoperated or automated servicing devices and/or by EVA astronauts. Manipulator arms will transport tools, parts, and astronauts as needed.

An initial engine maintenance philosophy centering on a modular engine packaging design was adopted as a baseline approach. Should a component fail, the module containing it can be replaced without removing the engine from the vehicle. Once off the engine the module can be returned to earth (or brought into the space station) for repair with lower handling and transportation penalties than if an entire engine assembly was involved. In addition, once off the engine, access to the components in a module is eased. A lesser volume and weight of on-orbit spares is required because a complete engine is not needed for each failure encountered. Drawbacks to modular maintenance include possible long work times involved because modules may have more interface connections and may require more post-maintenance checkouts, additional logistical effort needed to coordinate the greater number of deliverable assemblies, and the additional weight resulting from the use of space-operable couplings.

Besides the inclusion of modular maintenance capability, the initial philosophy is to provide a large amount of automation into engine maintainability. The goal is to minimize astronaut EVA effort required. Especially for relatively frequent inspections, servicing, and checkouts, automated equipment and remote manipulators should be capable of completing the tasks. EVA astronauts will be required as backup for failures in the remote equipment and for unusual tasks which are not automated.

An evaluation of this maintenance philosophy of performing removal and replacement (R&R) of components or component groups (modules) was made. This was done by comparing engine assembly versus module versus component R&R cost implications. In addition, ground versus space R&R of an engine component was compared. Although it must be noted that this assessment is first-order and applicable to one specific engine configuration, the cost differences are significant and should not be radically altered for similar designs.

The engine assembly versus module versus component R&R evaluation compared the cost of performing each operation in space with the cost of transporting the needed replacement part to the space station. Three specific cases were used, derived from the baseline 7.5K engine design:

- 1) Component - Fuel turbopump consisting of the T-mounted low pressure and high pressure fuel turbopumps.
- 2) Module - Fuel module consisting of the low and high pressure fuel turbopumps, main fuel valve, inlet fuel valve, and turbine bypass valve.
- 3) Engine Assembly - The entire engine assembly.

Timelines detailing R&R tasks were developed to determine the work times for each case. It was assumed that maintenance is to be accomplished at a space station servicing facility (vacuum environment) containing: (1) work platforms to support EVA astronauts or servicing robots, (2) a parts storage area with remote storage capability, (3) required tools and a tool storage area with remote stowage capability, (4) test and checkout equipment with remote stowage capability, (5) teleoperated manipulator(s) to translate tools, parts, and checkout equipment between storage and the work station, and (6) sufficient electrical, pneumatics and illumination to support the task.

The engine design features required to perform the required maintenance were: guides for self-alignment of mating parts, fluid interfaces which permit tools to remotely mate and demate, electrical interfaces which mate and demate simultaneously with the fluid interfaces, and an Integrated Control and Health Monitoring (ICHM) system which provides a complete assessment of engine health without the need for routine inspections.

It was also assumed that a three-person crew is to be used for EVA, namely (1) one EVA astronaut who actually performs the work, (2) one astronaut as an EVA backup and task coordinator, and (3) one astronaut inside the station to operate remote equipment.

Other assumptions made included: a 1990 technology level, EVA preparation times were not to be included, and the EVA astronaut is allowed ten minutes of rest per active work hour, but is considered at rest during remote operations.

The resulting timelines are depicted in Figures 15, 16, and 17. It should be noted that although these times were subjectively determined, they were influenced by space task time studies and the ground task times currently encountered with the Space Shuttle Main Engine.

OTV ENGINE FUEL TURBOPUMP REMOVAL/INSTALLATION/CHECKOUT TIMELINE

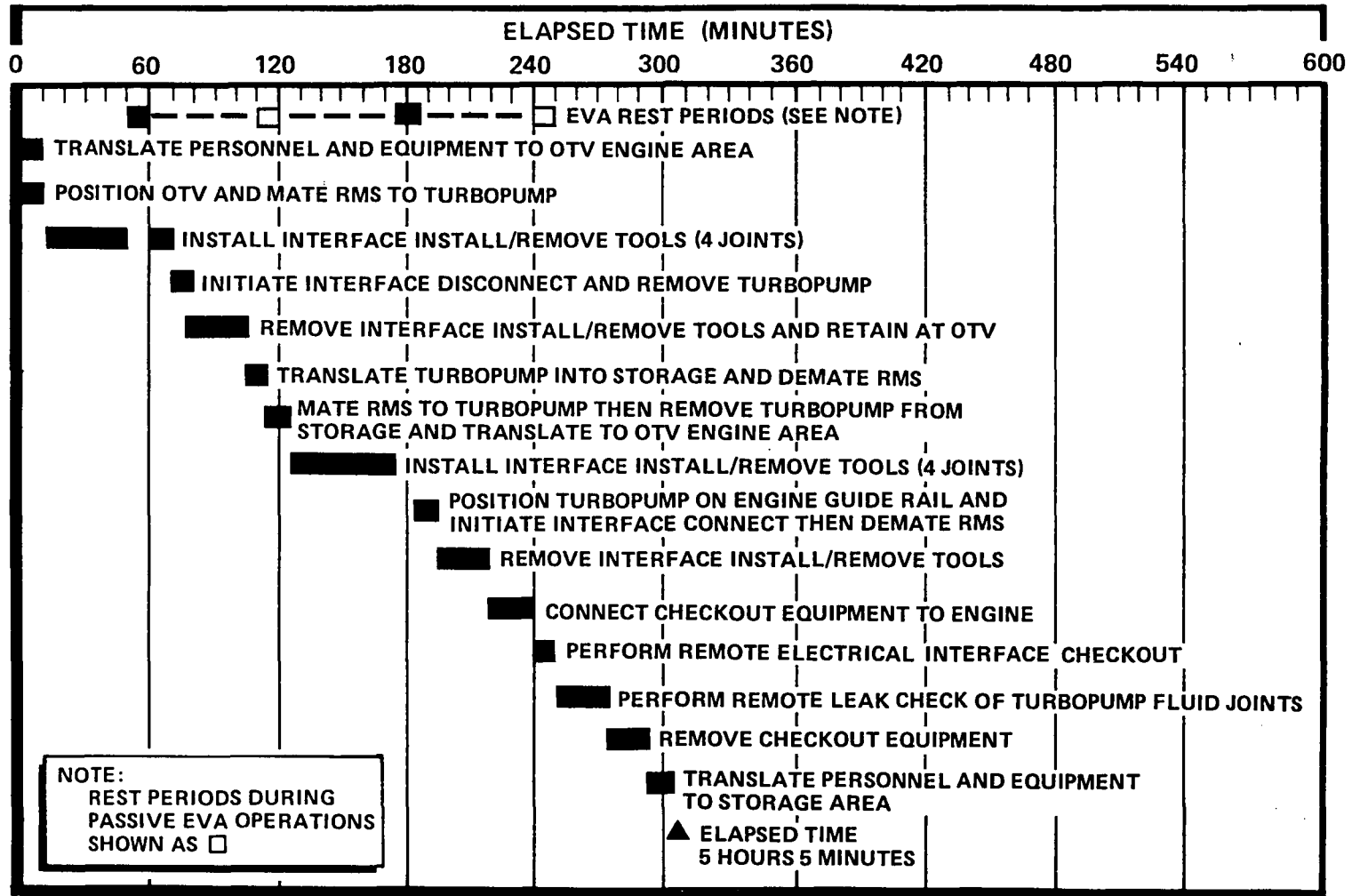

RI/RD86-116
75

489-405

FIGURE 15.

OTV ENGINE FUEL MODULE REMOVAL/INSTALLATION/CHECKOUT TIMELINE

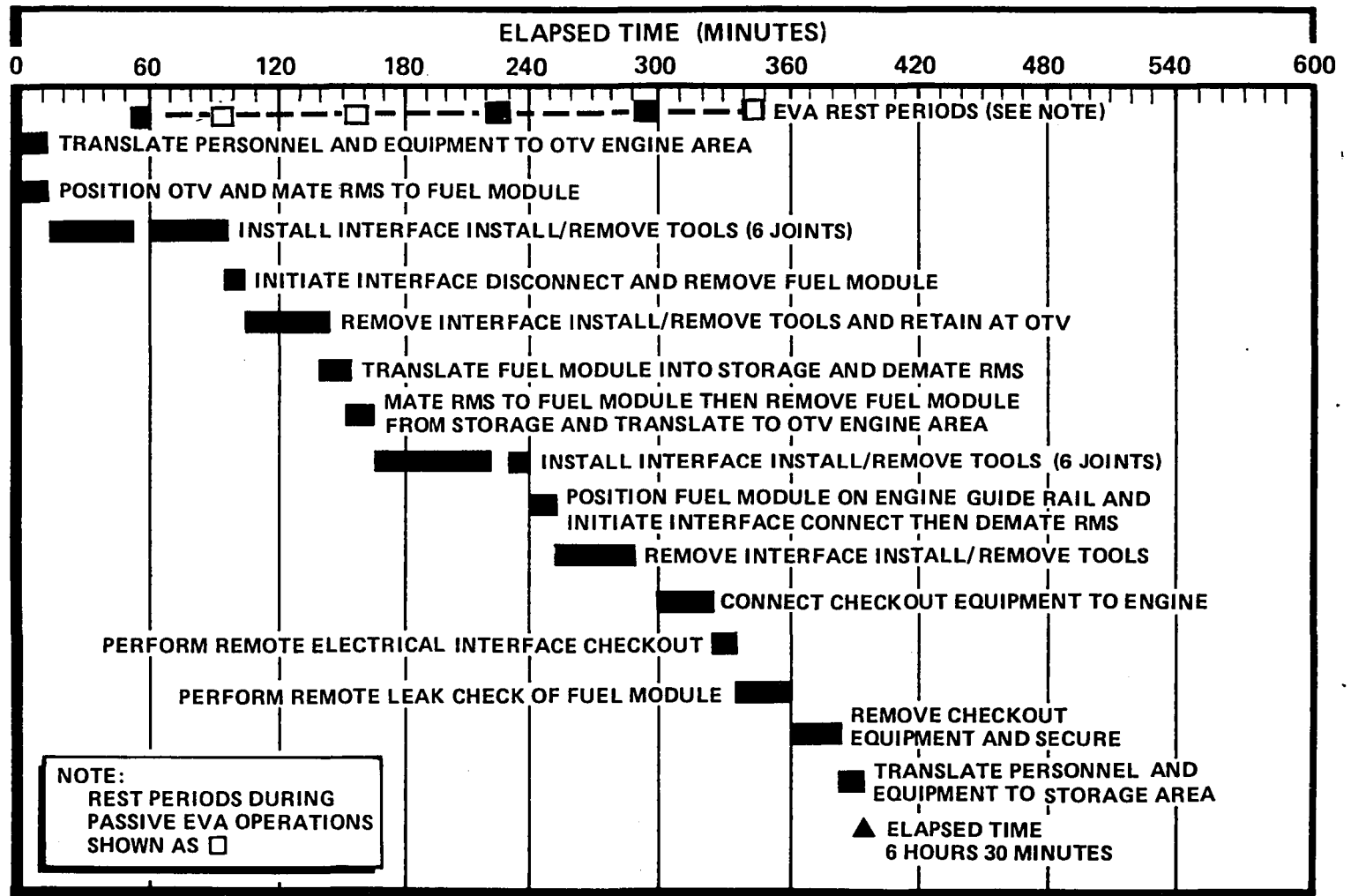

RI/RD86-116

76

489-388



FIGURE 16.

OTV ENGINE ASSEMBLY REMOVAL/INSTALLATION/CHECKOUT TIMELINE

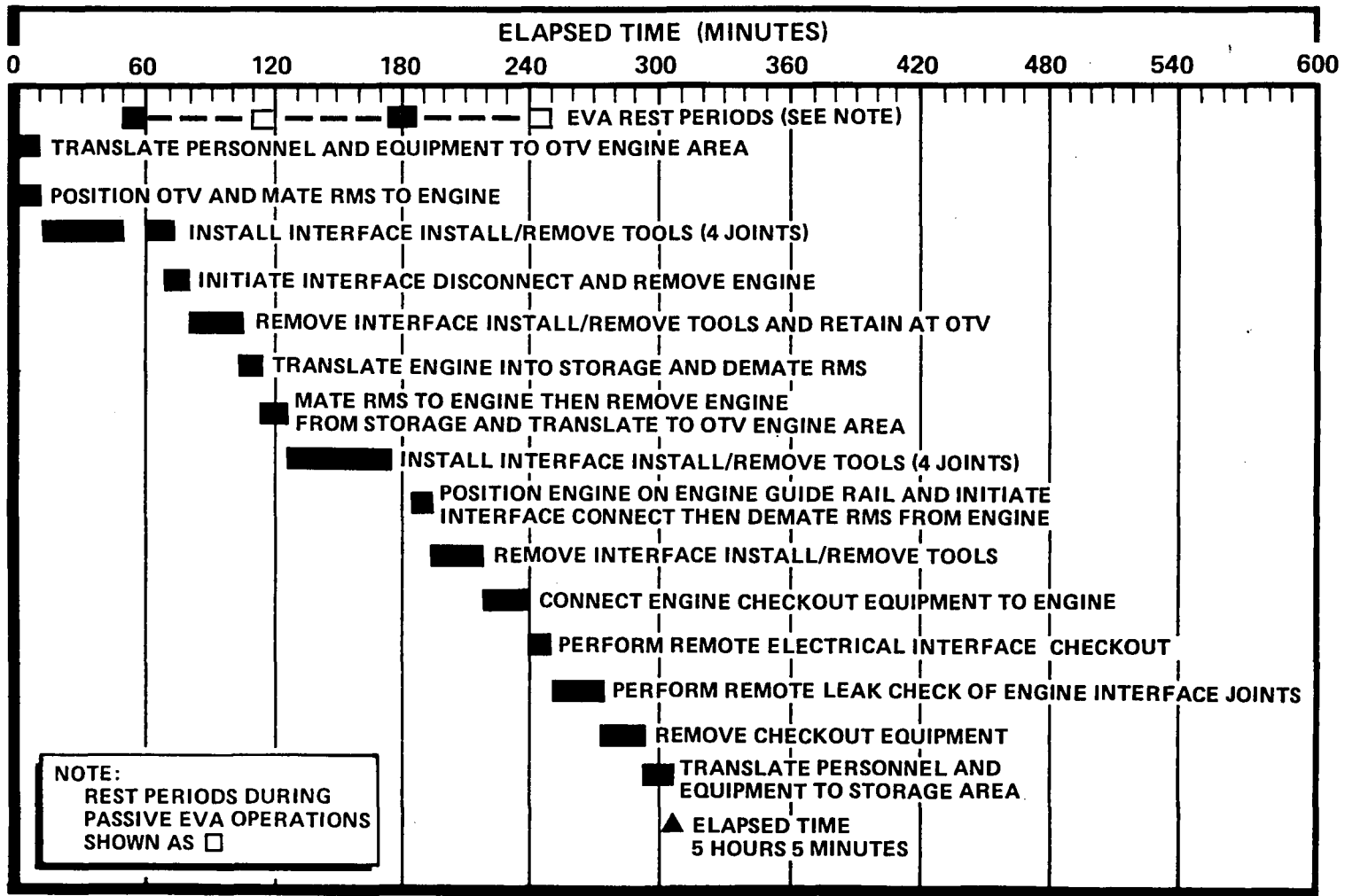

RI/RD86-116

77

489-389

FIGURE 17.

A cost of \$118,000 per hour was applied to these maintenance tasks. This cost includes the three person astronaut crew for EVA operations, EVA preparation, and ground support. A consensus of several space station studies was the basis of this figure. Because of the great similarity between tasks, skills, and equipment required for the three cases, development, facility, and training costs were assumed to be equal.

Transportation costs were established based on space shuttle cargo costs for the particular part replaced in each case. In other words, for module R&R, the cost of transportation was determined from the size and weight of the module; for engine R&R, the cost was based on the size and weight of the engine assembly. The cost figures used were the greater of \$1,631 per pound, or \$10,712 per cubic foot volume.

Table 29 details the cost comparison. For each case, weight and volume of the replaced unit is given, with the STS charges applied to determine which fee to use. It can be seen that the transportation costs of the component and module cases are based on weight, but for the engine, it is based on volume and is a considerably higher amount. The EVA task costs, based on the timelines, are then added to determine total R&R costs. Whereas the difference between component and module R&R is relatively small, and hence could be affected by other factors not considered in this first-order analysis, both are much less costly than engine R&R. This shows a clear advantage to sub-engine assembly (either component or module) R&R capability.

To examine the consequences of performing R&R tasks at a ground facility, a timeline was prepared for the case of removing a component after R&R in space and return to earth of an engine assembly. The T-mounted fuel low and high pressure turbopump was selected as the component to permit comparison with the previous timelines. The analysis assumes the task is performed by a crew of two with the engine mounted on an engine handler. The assumptions regarding the engine design remain the same. The timeline is shown in Figure 6-4.

TABLE 29.

COST COMPARISON OF R&R MAINTENANCE OPTIONS

	TURBOPUMP R&R	MODULE R&R	ENGINE R&R
WEIGHT (LB)	46	64	360
VOLUME (FT³)	1.2	5.0	115
WEIGHT COST (\$)	75,026	104,384	587,160
VOLUME COST (\$)	12,854	53,560	1,231,880
TRANSPORTATION COST	\$75,026	\$104,384	\$1,231,880
EVA TASK TIME (HR)	5.1	6.5	5.1
EVA COST	\$599,833	\$767,000	\$599,833
TOTAL COST	\$674,859	\$871,384	\$1,831,731
COST SAVINGS			
OVER ENGINE R&R	\$1,156,854	\$960,329	—

RI/RD86-116

79

489-406

OTV ENGINE FUEL TURBOPUMP REMOVAL/INSTALLATION/CHECKOUT TIMELINE (ON GROUND)

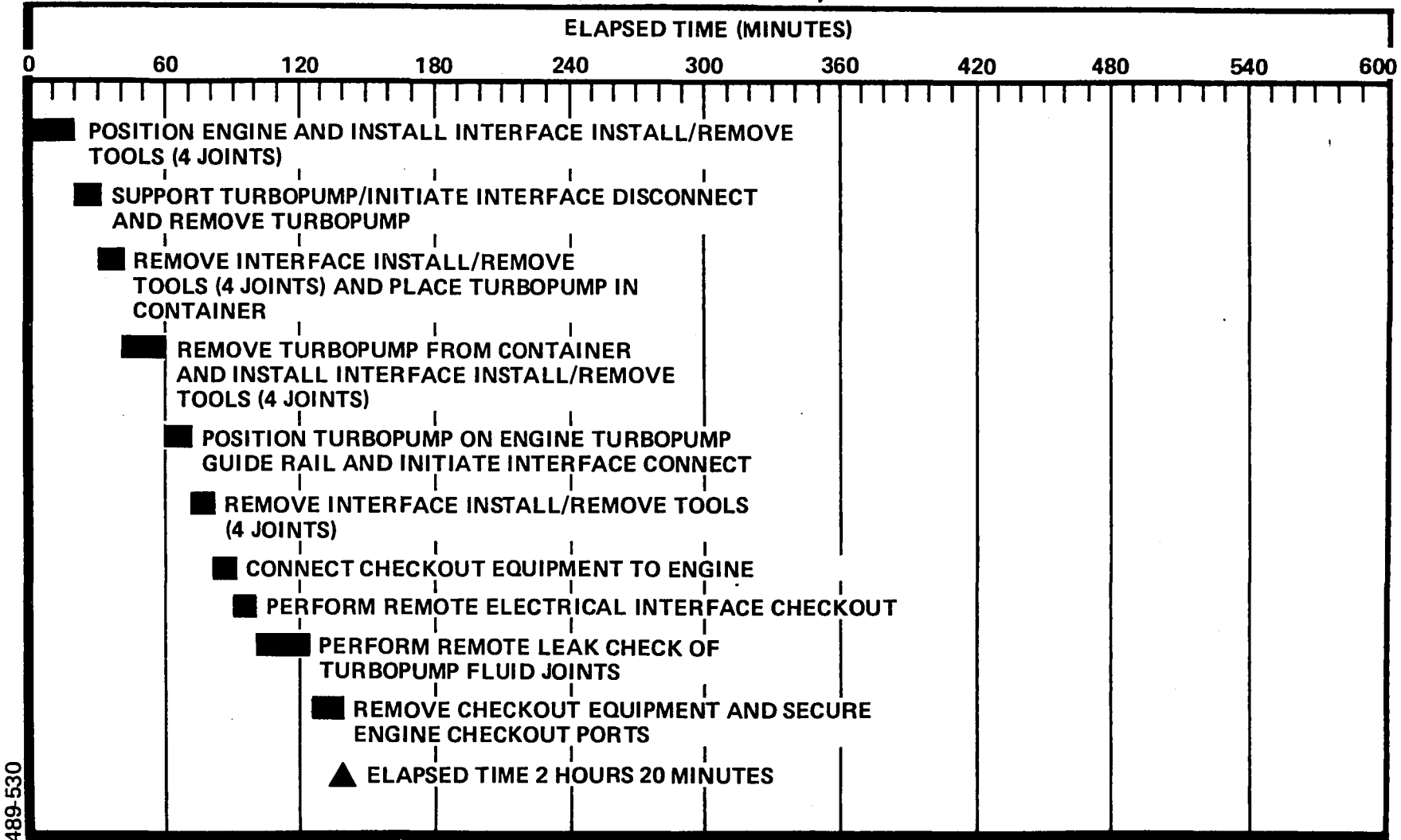

RI/RD86-116
80

489-530



FIGURE 18.

The cost associated with the ground task time is \$100 per manhour, or, with a two-person crew, \$200 per task hour. This is added to the cost of R&R and transport of the engine (from the previous analysis) to determine the total cost of ground maintenance.

The cost of space R&R of the turbopump is taken from the earlier analysis for comparison. This is shown in Table 30. It can be seen that the cost of ground tasks are trivial in light of EVA costs, even if it were to be much more extensive. However, EVA R&R is still required to return the engine to earth and the cost of transporting the engine back to the space station is very high. In-space R&R is therefore more economical for maintenance of a problem limited to one component (or module). Situations may arise (i.e., when several components are simultaneously approaching their predicted life limits) when ground R&R may be less costly, but with the capability for sub-engine space maintenance, this evaluation has shown that significant savings are possible for typical contingency maintenance needs.

A detailed list of engine maintenance requirements, based on the Space Shuttle Main Engine (SSME) needs, was defined for the engine life cycle under Task E.1. These 1983 state-of-the-art requirements were reviewed to determine applicability to the OTV engine design, as it differs significantly with the SSME. For example, the OTV expander cycle has no preburners and hence no requirement for their maintenance. There are other OTV engine maintenance requirements which can be eliminated by incorporating design changes, with respect to similar SSME components, based on different operating conditions and experience gained. For instance, with the drive fluid being a relatively cool hydrogen gas, rather than hot combustion gas as used with the SSME, some inspections can be simplified or reduced in frequency.

TABLE 30

GROUND VS SPACE R&R MAINTENANCE TIME AND COST

		GROUND R&R	SPACE R&R
TRANSPORTATION	UNIT COST	ENGINE \$1,231,880	TURBOPUMP \$75,026
<hr/>			
EVA	TIME	5.1 hrs	5.1 hrs
TASK-----	COST	\$599,833	\$599,833
GROUND	TIME	2.3 hrs	0
	COST	\$467	0
<hr/>			
TOTAL COST		\$1,832,180	\$674,859
<hr/>			

RI/RD86-116

82

491-142



Rockwell
International
Rocketdyne Division

By examining where advanced 1990 sensor and data analysis technologies can be used to reduce space maintenance, the instrumentation areas which are most beneficial (from a maintenance viewpoint) can be defined. So, using the 1983 state-of-the-art maintenance requirements as a basis, advanced technologies were identified which would either obviate or simplify each of the routine inspection needs. These advanced instrumentation areas, listed in Table 31, also provide other benefits to the engine, such as improved control and reduced life cycle costs.

A maintenance plan is being developed for the space-based and space-maintained advanced OTV engine. The plan encompasses definition of maintenance requirements, maintenance functions, and maintenance benefits. Its development has been started during this phase of the program (FY'85) and will continue during the follow-on phase (FY'86). Requirements, functions and benefits are further outlined in Figure 19.

Requirements

Requirements are used in a general sense. It encompasses engine requirements as well as component requirements. The starting point for these requirements is the vehicle and the mission. Included in these requirements affecting the maintenance plan are engine and component life, as required by the number of missions desired before maintenance actions are undertaken; engine and component reliability as required by vehicle reliability goals; and crew-safety requirements. The approach for each is discussed below.

Component Life. As part of the maintenance plan, component life will be established. At this point in time, the calculated life is known for the key engine components from simple one-dimensional analyses. The approach has been to design the components for the desired near-term goal of 300 cycles and 10 hours of operating time before overhaul. The near-term 15K engine was designed

TABLE 31.

CONTROL AND HEALTH MONITORING INSTRUMENTATION

PARAMETER	NEAR TERM SENSOR	FAR TERM SENSOR
FLOWRATE	TURBINE	ULTRASONIC
IGNITER SPARK	VOLTAGE, CURRENT	FIBEROPTIC PHOTOMETER
VALVE POSITION	LVDT	FIBEROPTIC POSITION
ACCELERATION	ACCELEROMETER	ACCELEROMETER
PRESSURE	STRAIN GAGE DIAPHRAGM	FIBEROPTIC DIAPHRAGM
TEMPERATURE	THERMOCOUPLE, RTD	ULTRASONIC
SHAFT SPEED	VARIABLE RELUCTANCE	VARIABLE MAGNETIC
BEARING WEAR	ISOTOPE DETECTOR	ISOTOPE DETECTOR
BEARING CONDITION	FIBEROPTIC DEFLECTOMETER	FIBEROPTIC DEFLECTOMETER
PUMP TORQUE	TORQUE WRENCH (BETWEEN MISSION)	MINIATURE TORQUEMETER
LEAKS	MASS SPECTROMETER (BETWEEN MISSION)	PULSED HOLOGRAPHIC (BETWEEN MISSION)
MIXTURE RATIO	TURBINE FLOWMETER	SPECTROMETRIC SPECIES
NOZZLE POSITION	OPTICAL DETECTOR	OPTICAL DETECTOR

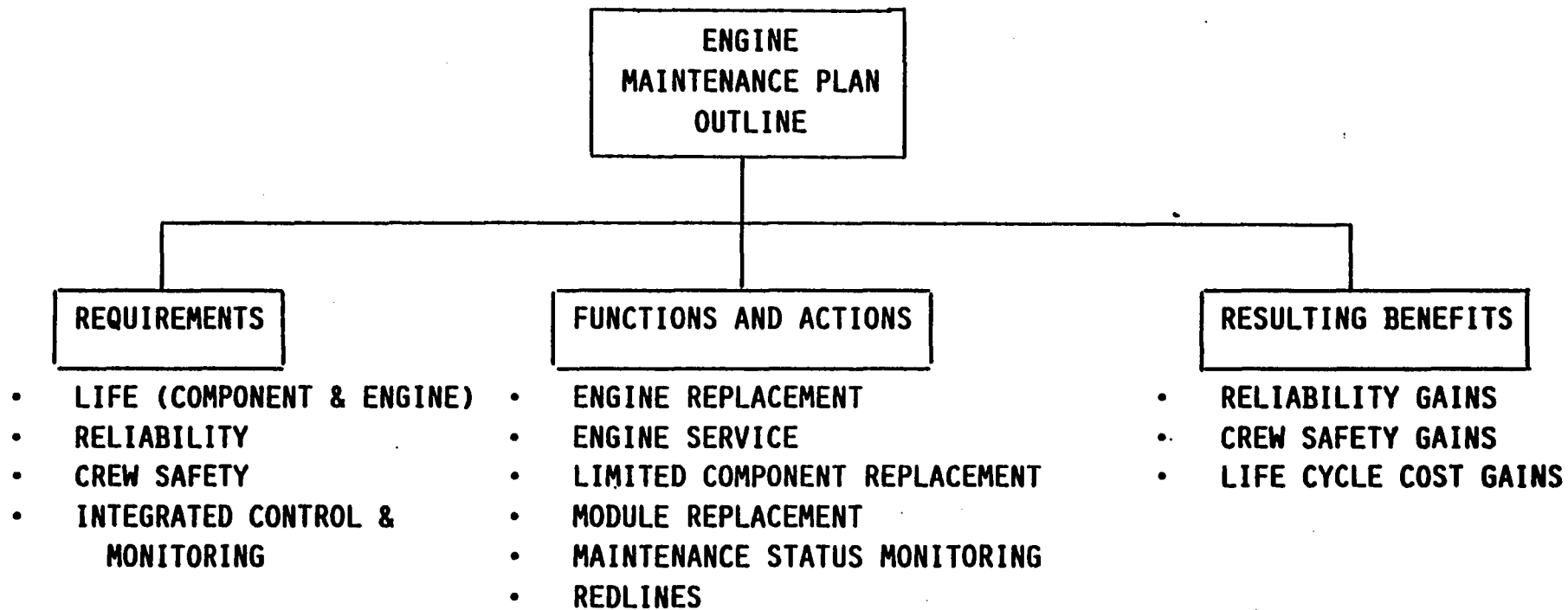

FIGURE 19. MAINTENANCE PLAN OUTLINE

with this approach in mind. A point-design has been obtained (NAS8-33568) for that engine with component life based on simplified analysis anchored on a baseline finite element analysis for the thrust chamber and on simplified analysis for the turbopump bearings and seals. Life for the components analyzed is indicated in Table 32. As indicated in the table, some component lives are yet to be determined.

For the current 7.5K engine concept, component life goals are far-term values of 500 cycles and 20 hr. before overhaul. No baseline detail analysis exists on which to base the simplified life analysis for this latter thrust level.

Life and Reliability - Relationship. Reliability is a function of component service time at rated condition and number of starts and shutdown cycles. Each mission requires a number of starts and shutdowns and a certain length of time at rated conditions. The true engine life is established by the number of missions at which the engine reliability drops below the desired value from mission considerations.

The true life of a component is not known until sufficient testing has been performed and a statistical average value has been established. A maintenance schedule based on true life is the most cost effective. In the absence of true life values, calculated life is used for each component to determine maintenance frequency and component reliability. Because of the conservative nature of the analytical methods, component calculated life is believed to be many times lower than true life. It is one of the objectives of the maintenance plans to define actions required to (1) base component maintenance on cause (true life) rather than on routine schedule (calculated life), and (2) extend component life through changes in the operating environment.

Life Extension. Component life can be extended through the use of a Health Monitoring System which by monitoring certain parameters, keeps track of and forecasts true life and can take actions to operate the component in a less demanding life-extending mode through adaptive control.

TABLE 32. ENGINE COMPONENTS LIFE,
15K LB NEAR-TERM ENGINE

	<u>LIFE CYCLES</u>	
	CALCULATED	+ S.F. = 4
INJECTOR	TBD	TBD
COMBUSTION COOLING JACKET	1200	300
NOZZLE COOLING JACKET	1200	300
FUEL TURBOPUMP BEARING	1200	300
OXIDIZER TURBOPUMP BEARINGS	1200	300
FUEL TURBOPUMP SEALS	1200	300
OXIDIZER TURBOPUMP SEALS	1200	300
FUEL TURBOPUMP SOFT-SEALS	1200	300
OXIDIZER TURBOPUMP SOFT-SEALS	1200	300

Mean Time to Failure. Random variation of component life in a statistical sample is caused by variation of life affecting factors not known or not easily characterized. The mean value of the remaining life is known as the mean-time-to-failure (MTTF). The MTTF can be used in calculating reliability and can be updated and improved as the statistical sample increases. A health monitoring system can provide the function of updating the MTTF.

Failure Rates. Failure rate (λ) is the inverse of the MTTF which has the units of time in hours (hr). The units of λ are 1/hr. As MTTF, λ is a statistical quantity and is used in reliability studies.

Reliability Requirements. The overall reliability of each component is defined as the product of start reliability (R_s) and the mainstage reliability (R_m) for one operational cycle. When "n" number of cycles is involved, the overall reliability is defined as:

$$R = R_s^n R_m$$

Using the failure rates associated with mainstage (λ_m) conditions, component reliability can be defined as:

$$R = R_s^n e^{-\lambda_m t}$$

Engine Reliability. The reliability of the engine is the product of "k" number of component reliabilities so that:

$$R_{ENG} = \prod_{i=1}^k R_i^n e^{-\lambda_{m_i} t}$$

where \prod represents the product of component reliabilities from $i=1$ to k . The engine reliability R_{ENG} is thus a measure of all component mean-time-to-failure values and represents in one parameter the readiness of the engine to perform the next mission. Because of the "adaptive control" features of the

ICHM system and its monitoring capabilities, engine reliability can be changed by the ICHM. Also the predicted life can be extended by the ICHM by reducing dependency on Safety Factors used in calculations, since MTTF is measured and monitored in and between flights.

Redundancy and Crew Safety. Redundancy is also an engine feature used to influence engine MTTF through switching from a component near to failure to a fresh or redundant component. In the same manner, the engine system overall reliability is influenced through use of redundant engines. Redundant engine reliability for two engines (RR_{ENG}) is defined as:

$$RR_{ENG} = R^2 + 2R(1-R) \quad (\text{without non-independent failure } R)$$

Reliability Requirements. The budgeted reliability for the engine comes from knowing the minimum reliability desired for the vehicle for (1) mission accomplishment, and (2) crew safe return. Two values of reliability are thus required. For the ICHM to control engine actions, it needs to know the budgeted engine reliability to achieve vehicle required mission reliability and crew-safety reliability.

ICHM Requirements. ICHM requirements for extending engine life and reliability are discussed in this section.

Function Allocation and Logic Diagram. A preliminary first level function allocation and logic diagram for the ICHM is shown in Figure 20. It consists of a control system block, a trend analysis function block, and an on-line monitor function block. Sensors in the control system provide data for the trend analysis function system where MTTF is determined with historical statistical data banks from engine testing and previously accomplished missions. MTTF forecasting is used to (1) continue with the next mission with no other action, (2) to determine post-mission maintenance actions, or (3) exercise adaptive control for remainder of mission. For the latter, the on-line monitor system is exercised and component parameter modification is calculated and effected through the control system.

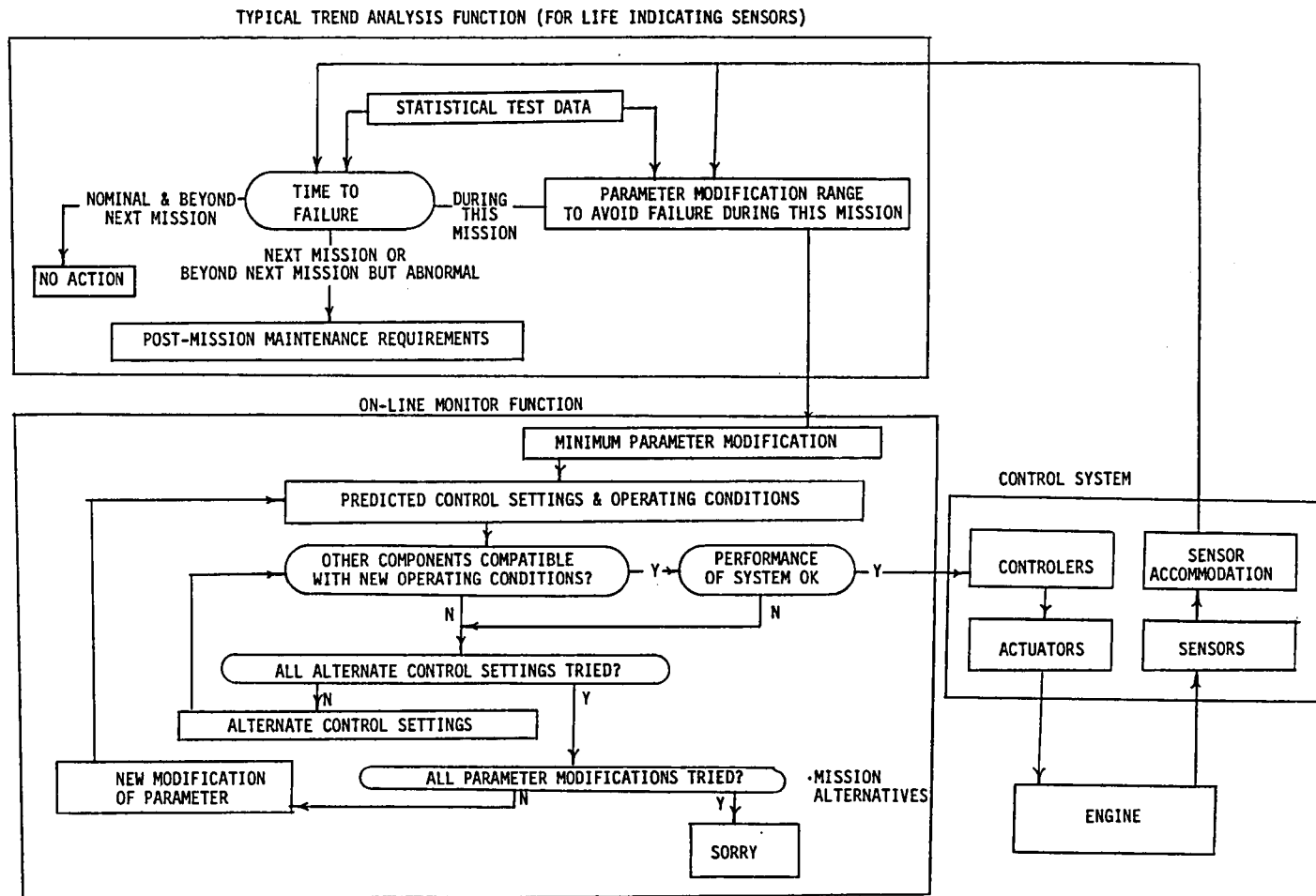

FIGURE 20. ICHM FUNCTION ALLOCATIONS AND LOGIC DIAGRAM

ICHM SYSTEM REVIEW

Effort completed in ICHM system review is covered in the previous section on FME mitigation and reliability improvement through ICHM evolution.

VEHICLE/SYSTEM INTEGRATION

To successfully implement space maintenance concepts, advanced interface joints must be developed. They must permit coupling/decoupling on-orbit by astronauts in space suits and/or by robotic servicing devices. Whether they apply to component, module, or engine system interfaces, they must be easy to use and reliable during coupling tasks, highly reliable throughout engine operation, and not add significant penalties to weight, envelope, and reliability.

Propellant, pneumatic, structural, power, and data interface types are involved. They are enumerated for each module, as well as the overall engine system, in Table 33. The pneumatic joints were separated from the propellant interfaces because they form a clearly identifiable (pressure, temperature, fluid) class of joints for study. With the engine core used as a structural bus, the structural couplings provide primary mechanical support for each module, as well as the vehicle interfaces at the gimbal and gimbal actuator attach points. Electric power and data (electric or fiber-optic control and health monitoring signal) interfaces, although numerous, can be grouped into larger connectors to significantly reduce the numbers of individual joints which must be separated. Most of these disconnects are located directly between the controller and modules or controller and vehicle without passing through the core module. These power and data interface needs are preliminary and may be altered as the ICHM system definition progresses.

This study focused on the propellant interface couplings. These components are major determining factors on the feasibility and level of space maintenance. However, no satisfactory concepts for flightweight, cryogenic, high pressure, space-operable fluid couplings which meet the needs of this engine have been previously developed. On the other hand, space-operable structural and electrical coupling devices have been used or proposed for other space applications.

TABLE 33.

ADVANCED INTERFACES ENABLE SPACE MAINTENANCE

MODULES	NUMBER OF INTERFACES				
	PROPELLANT	PNEUMATIC	STRUCTURAL	ELEC. POWER	DATA *
FUEL	6 MOD/MOD 1 ENG/VEH	2 MOD/MOD	1 MOD/MOD	2 MOD/MOD	25 MOD/MOD
OXIDIZER	5 MOD/MOD 1 ENG/VEH	2 MOD/MOD 1 ENG/VEH	1 MOD/MOD	7 MOD/MOD	29 MOD/MOD
CORE	8 MOD/MOD 2 ENG/VEH	0	5 MOD/MOD 3 ENG/VEH	7 MOD/MOD	21 MOD/MOD
NOZZLE	1 MOD/MOD	0	2 MOD/MOD	1 MOD/MOD	2 MOD/MOD
CONTROLLER	0	0	1 MOD/MOD	17 MOD/MOD 1 ENG/VEH	75 MOD/MOD 5 ENG/VEH
SYSTEM	11 MOD/MOD 4 ENG/VEH	2 MOD/MOD 1 ENG/VEH	5 MOD/MOD 3 ENG/VEH	17 MOD/MOD 1 ENG/VEH	75 MOD/MOD 5 ENG/VEH

* MANY OF THESE ARE COMBINED TO REDUCE NUMBER OF ACTUAL CONNECTORS

RI/RD86-116

93

491-143



**Rockwell
International**
Rocketdyne Division

Fluid joints must satisfy both mechanical coupling and fluid containment tasks. Seal integrity and application of the required seal loading throughout the component life are of central importance. Rocketdyne's experience has shown that pressure actuated face seals offer superior performance over other designs for high pressure systems. Although detail design considerations govern the specific seal design for each joint, the seal is not considered a technology issue with respect to space-operable disconnect couplings. Figure 21 shows a seal design which was used as a baseline for the coupling concepts generated in this task. The primary seal points are pressure assisted, yet the seal heel has gasket points for redundant sealing capability. The teflon coating (gold for high temperature joints) gives a light interference fit at the outside diameter so as to retain the seal in the gland prior to assembly of the coupling. This minimizes potential seal damage and assembly operations.

The technology concern for space-operable disconnects is the mechanical coupling mechanism. It must carry the required seal loading and be easy to couple/decouple, yet must not impose large envelope or weight penalties. Literature searches and design studies were undertaken to identify concepts applicable to these needs. Most existing designs were intended for ground use where weight is of secondary concern. Others were designed solely for couple or decouple operation and were inherently not applicable to both space connect and disconnect requirements. The concepts judged of possible use are described below.

Although a state-of-the-art bolted joint could be coupled on orbit, the number of separate elements and assembly operations makes this an undesirable choice. A more acceptable design is a simple bolted flange joint which is limited to four fasteners to reduce the task time required to make a connection. As shown in Figure 22, captive fasteners are used to eliminate the need to assembly many loose parts in space. This concept benefits from a wealth of previous aerospace application but is not particularly fast to operate. It is relatively simple and low cost, but weight is significantly increased over an optimum 8-10 bolt configuration. Also, although the use of four fasteners speeds assembly, the redundancy against failed or incorrectly installed fasteners, which is an inherent feature of bolted joint, is severely compromised.

SELF-RETAINED, REDUNDANT SEALING FACE SEAL CONCEPT

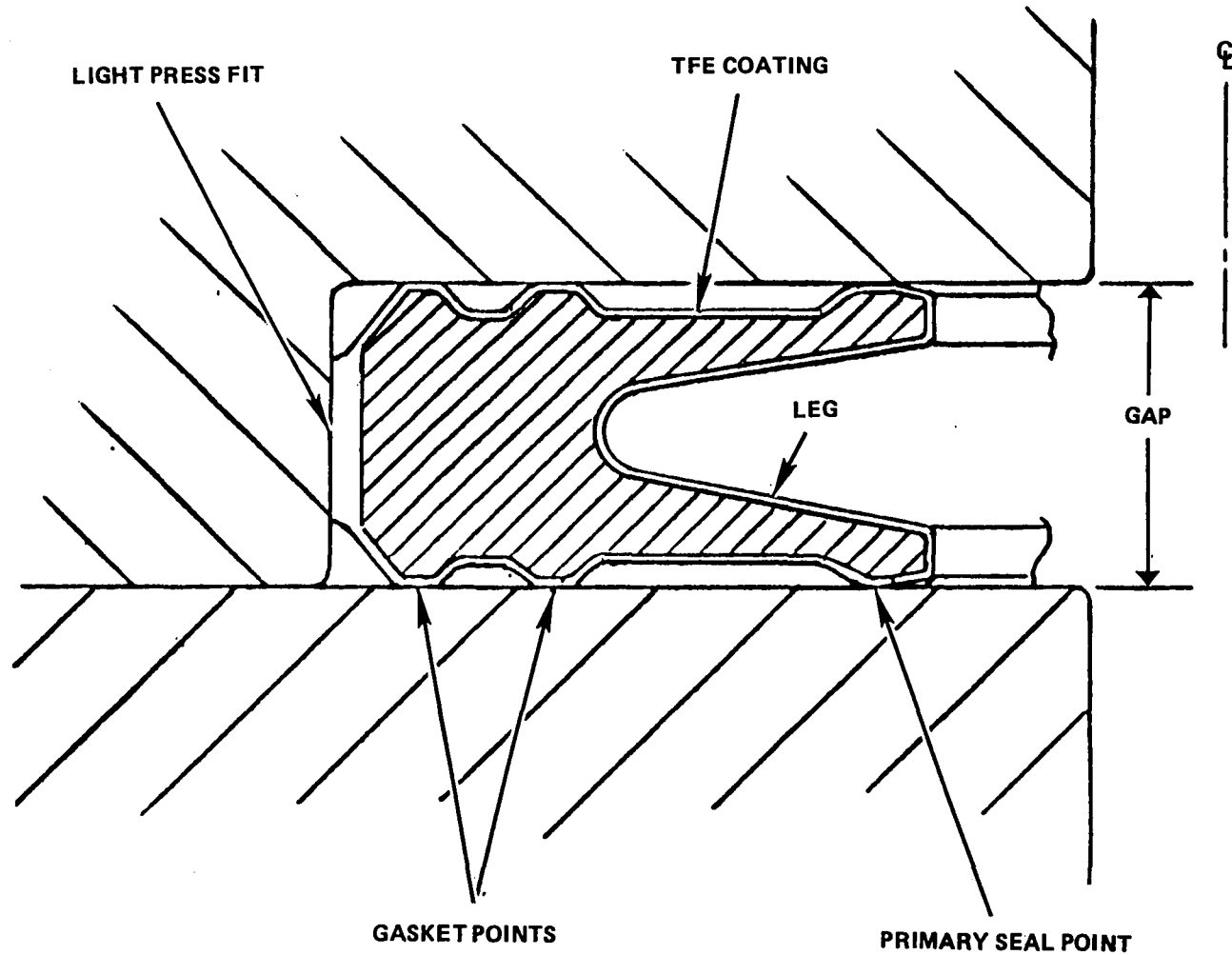

95
RI/RD86-116

488-629

FIGURE 21.

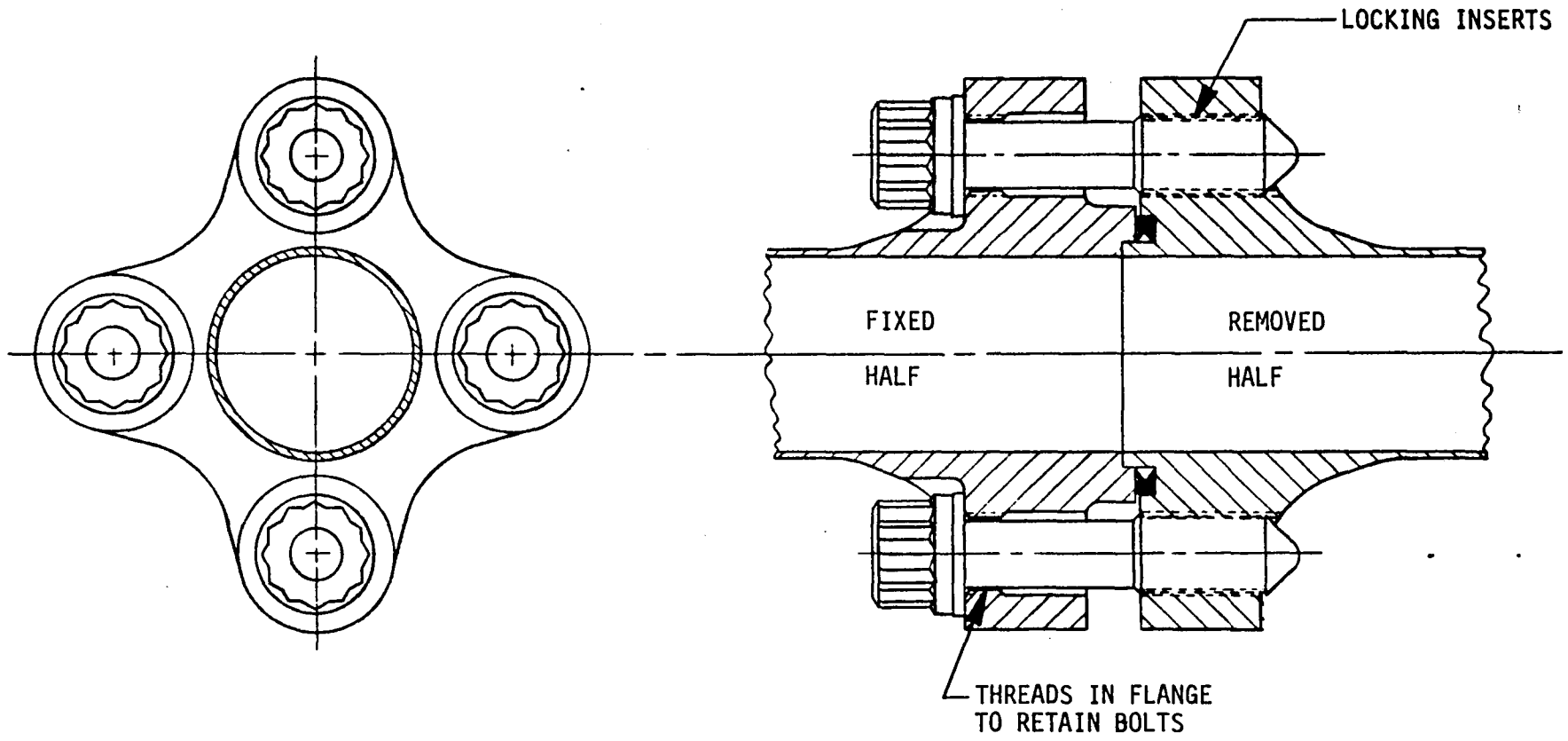

FIGURE 22. Captive-Bolt Disconnect Joint

A very different interface concept, shown in Figure 23, features a simple fixed coupling half with the entire mechanism contained on the removable half. A rotating drive sleeve (which may be either manually actuated or powered) causes a carriage to axially translate fore or aft. Splines prevent rotation of the carriage. Hooks are mounted to the carriage with springs to normally hold them in the assembled, or closed, position. As shown in the upper view, the hooks are forced to rotate clear of the fixed flange as the coupling begins to connect. When the fixed flange nears seating, the hooks are free to snap back against their stops. Actuation of the drive sleeve causes the carriage to translate until the hooks contact and load the back of the fixed flange. Proper loading of the joint can be determined by torquing the drive sleeve or by measuring the strain on each of the easily accessible tension legs of the carriage. To disconnect, a split-sleeve tool (not shown) is slipped around the fixed half tube. As the drive sleeve moves the carriage to the open position, the tool forces the hooks to open until the coupling halves are separated. This concept is referenced as the "Carriage Hook" design.

This concept uses a moderately complex mechanism which is simple and fast to operate. Loads are applied close to the seal nearly continuously around the joint so that flange size is minimized. A negative feature is the close tolerances required to assure symmetrical loading on the hooks. This results in high fabrication costs compared with some of the other concepts. Another drawback is the need for a separate tool to open the hooks at disconnect. Although simple for an astronaut, this tool may be difficult to operate robotically. With acceptance of an attendant weight penalty, a hook-opening mechanism could be added to the carriage to simplify operation of the coupling.

The concept shown in Figure 24 utilizes 12 "U" shaped spring elements, incorporated in a collar, to preload the flanges. The collar slides over the flanges and a tool applies the pre-load force. A locking ring with slots matching the slots in the collar is rotated 30 degrees, prior to removal of the tool, to lock the pre-load. Friction on the ring due to the pre-load between the collar and the flange is sufficient to prevent the ring from turning in high vibration environments. This design is known as the "Spring Collar" concept.

CARRIAGE/HOOK COUPLING CONCEPT

98
RI/RD86-116

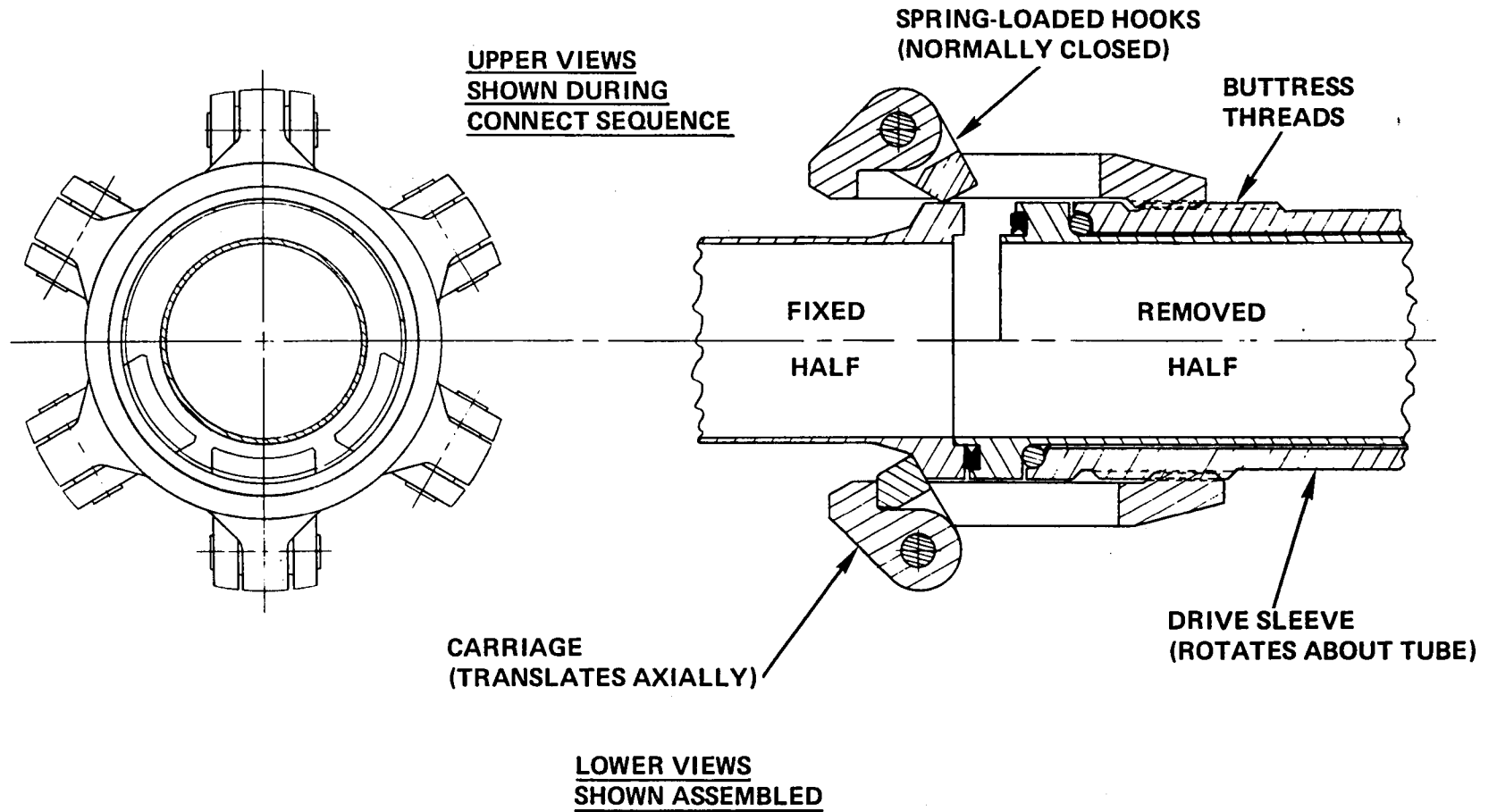

491-144



Rockwell
International
Rocketdyne Division

FIGURE 23.

PATENT DISCLOSURE HAS BEEN SUBMITTED
ON SUBJECT CONCEPT. NASA WAIVER BEING
SOUGHT FOR FOREIGN AND DOMESTIC RIGHTS.

SPRING-COLLAR INTERFACE COUPLING CONCEPT

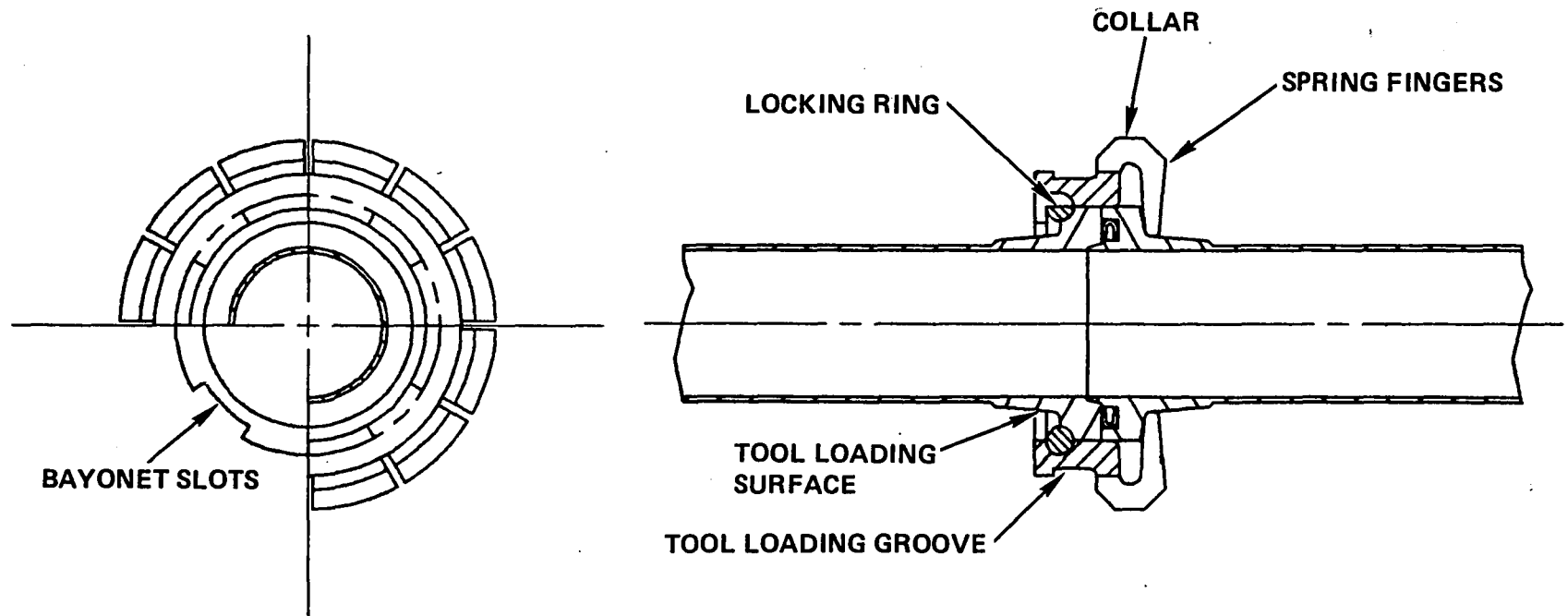

RI/RD86-116
99

491-145



Rockwell
International
Rocketdyne Division

FIGURE 24.

PATENT DISCLOSURE HAS BEEN SUBMITTED
ON SUBJECT CONCEPT. NASA WAIVER BEING
SOUGHT FOR FOREIGN AND DOMESTIC RIGHTS.

The primary feature of this design is that joint preload is a function of joint configuration and not installation technique. The concept eliminates the need to torque individual fasteners to a close monitored value because the preload is provided by spring elements that apply an equal force (as a function of collar displacement) around the back side of the flange.

Other features include weight comparable to an optimum bolted joint, few required parts, and no loose parts when disconnected. No off-axis loading is applied which may tend to cock flanges during assembly. Effort and the possibility of seal/gland damage during assembly is reduced. The design is tolerant to joint misalignment, both lateral and rotational.

A disadvantage of the Spring Collar concept is that since the preload is a function of joint configuration, the parts must be manufactured with close dimensional tolerances. To ensure a smooth finish and matching contact, the locking ring and the surfaces that it bears against must be ground. Also, damage to the spring elements may not be visually detected, but change joint preload.

The simplified coupling task is made possible by using one tool which can be remotely operated. One concept for this tool is shown in Figure 25. It consists of a scissor jack with a telescoping pivot. The load is applied between two split trunnions to allow the tool to fit over the tubing. After the trunnions are clamped around the joint, a jack screw closes the scissor which applies a load between the back side of the left flange, and the groove on the collar. This unloads the locking ring, so it is free to turn. The ring is turned 30 degrees by a lever that engages with a slot on the ID of the ring. The jack screws could be driven by a hand crank, pneumatic wrench, or gear motor. This allows either hand or remote operation.

The "Segmented Thread" concept, shown in Figure 26, uses a large coupling nut with buttress threads. The threads are axially segmented so that the mating halves may be inserted together until seal contact is made. The halves are indexed so that the threads begin to mesh and apply load as the nut is turned. Less than 30° of nut rotation is required to produce the desired joint loading, after which locking tabs (not shown) are inserted between the segments to lock the joint.

SPRING-COLLAR COUPLING INSTALLATION TOOL

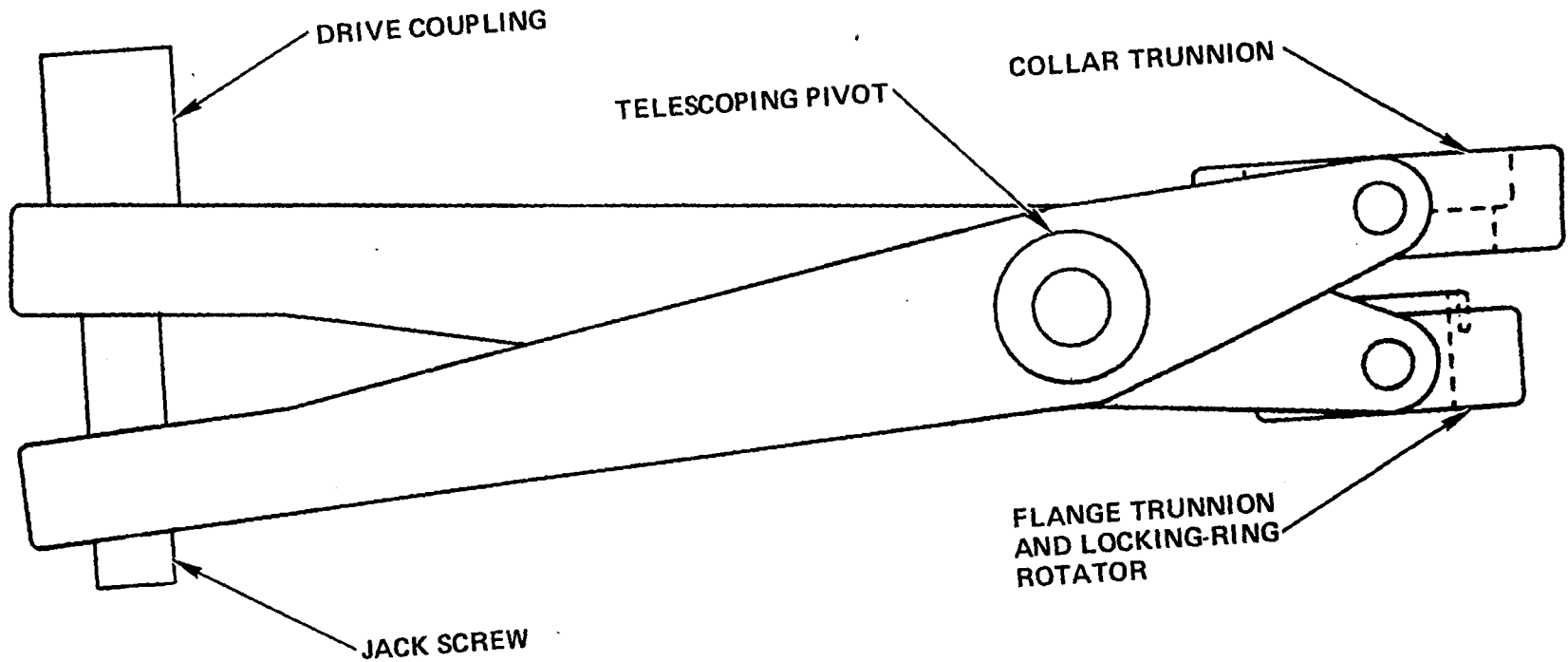

FIGURE 25.

RI/RD86-116
101

491-146

SEGMENTED-THREAD COUPLING CONCEPT

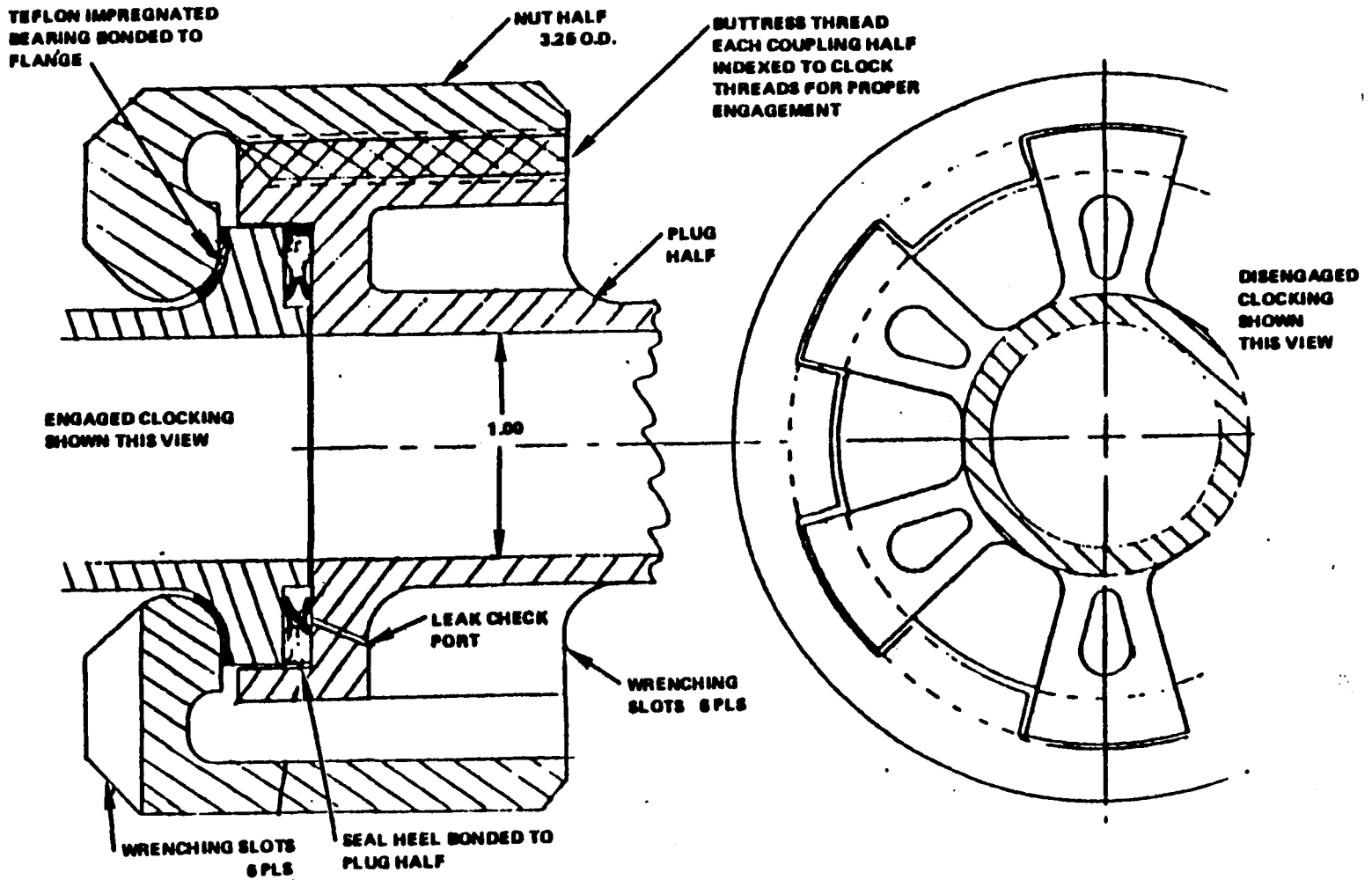

FIGURE 26.

102
RI/RD86-116



This design offers an advantage over other single-nut couplings in that very little nut rotation is needed before the loading is applied. It is therefore faster and easier to couple. However, it suffers from the inherent drawback of having the joint preload being sensitive to small nut rotation. Relatively high torque, which is difficult to apply as an EVA, is also required to set the proper preload.

Another concept is configured so as to preset the desired preload into the joint at the time of manufacture. The coupling nut has a relatively long thin section which is stretched by tooling attached to the flange abutment and nut threads in a manner similar to the tube end fittings. Compression members are installed between shoulders on the nut so that when the tool is removed, the thin sections remain stretched. When transported to and installed on the engine, the joint is lightly snugged up to obtain flange contact. The mechanism is then actuated, thereby causing the preload to be carried through the tube flanges and seal. Inasmuch as the preload is lost after each use, the joint portion of the joint is contained on the replaceable component half of the interface. The benefit of this type of coupling lies in the ability to preset the desired joint preload on the ground or as an IVA task, rather than as a less cost effective EVA effort. This design is referenced as the "Preset Preload" concept.

Four commercially available concepts were included. The Conoseal V-Band coupling, Figure 27, uses a V-band clamp with an over-center latch and loading nut to join two flanges. A conical washer seal is contained between the two flanges. This concept is developed and relatively light weight, but the preloading characteristics of the clamp make it more suitable for low pressure, rather than high pressure, applications.

The Gamah Edge Seal Coupling consists of a B-nut style fitting which uses a washer type seal, Figure 28. The washer deforms on its inner and outer edges to seal against the mating halves of the coupling. Multiple seals can be incorporated and the concept is rather tolerant of flange separation.

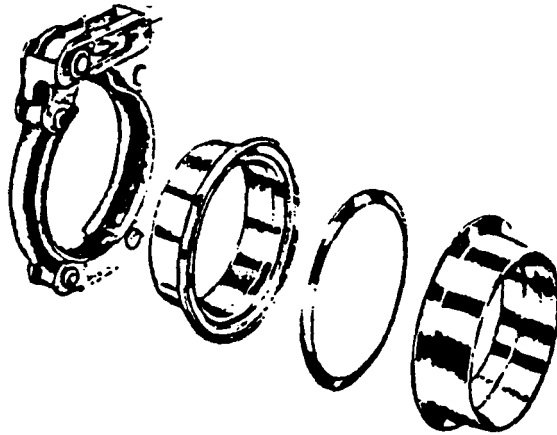

Figure 27. Conoseal V-Band Coupling

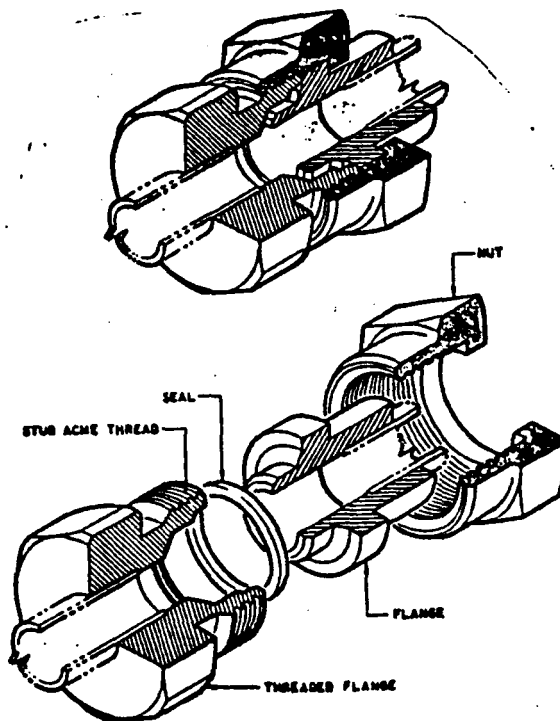

Figure 28. Gamah Edge Seal

The Dynatube Coupling is another B-nut design which incorporates an integral seal element, Figure 29. It is tolerant of flange separation but, should the seal be damaged, it is not replaceable.

The Parker Lo-Torque Coupling, Figure 30, is another B-nut style design. A conical/spherical metal-to-metal contact between the two halves serves as the seal. Although low-cost, the seal is not replaceable and the joint has low tolerance for flange separation.

In order to simplify the evaluation of the concepts, the joint locations and environment requirements were determined and combined into three groups with similar requirements. Table 34 lists these locations and conditions. The three evaluation groups are summarized below:

Group I

Joint Numbers 2, 3, 4, 6, 7, 10

Pressure 1830 - 6534 psi

Temperature 153 - 1129°R

Line size .750 - 1.250 inch

Group II

Joint Numbers 1, 8, 13, 14

Pressure 16.3 - 18.8 psi

Temperature 37.8 - 162.7°R

Line Size 2.125 inch

Group III

Joint Numbers 5, 9, 11, 12

Pressure 1830 - 4873 psi

Temperature 179 - 1179°R

Line Size .188 - .250 inch

The worst case application for each group was used to evaluate the coupling concepts. For example, in Group I, this is joint number 3 where, compared to joint number 2 the high temperature affects material properties more than loads are decreased by the lower pressure.

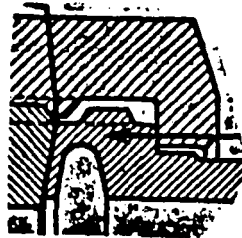
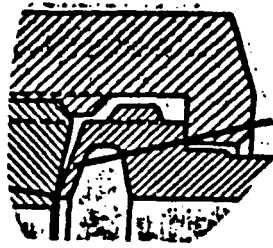

Figure 29. Dynatube Coupling

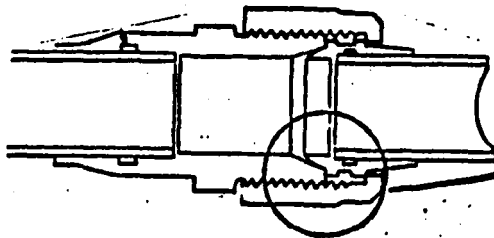

Figure 30. Parker Lo-Torque Coupling

FUEL MODULE	JOINT NO.	LINE SIZE (IN.)	PRESSURE (PSI)	TEMPERATURE (°R)	FLUID
IFV Inlet	1	2.125	18.8	37.8	Hydrogen
MFV Outlet	2	1.000	6534	153	Hydrogen
HPFI Inlet	3	1.125	4872	1129	Hydrogen
HPFI Outlet	6	1.250	2167	989	Hydrogen
TBV Outlet	4	.750	1830	1120	Hydrogen
LPFI Outlet	5	.250	1830	986	Hydrogen
OXIDIZER MODULE					
IOV Inlet	8	2.125	16.3	162.7	Oxygen
MOV Outlet	10	1.125	2174	182	Oxygen
HPOT Inlet	6	1.250	2167	989	Hydrogen
HPOT Outlet	7	1.250	1830	986	Hydrogen
LOX HEX Inlet	9	.250	2577	179	Oxygen
CORE MODULE					
MFV Outlet	2	1.000	6534	153	Hydrogen
MOV Outlet	10	1.125	2174	182	Oxygen
HPOI Outlet	7	1.250	1830	986	Hydrogen
LPFI Outlet	5	.250	1830	986	Hydrogen
HPFT Outlet	3	1.125	4872	1129	Hydrogen
TBV Outlet	4	.750	1830	1120	Hydrogen
LOX HEX Inlet	9	.250	2577	179	Oxygen
Fuel Pressurization	11	.188	18.8	37.8	Hydrogen
Oxid Pressurization	12	.250	16.3	162.7	Oxygen
Extendible Nozzle	15	~34.500	~1.0	~2500	Combustion Gas
NOZZLE MODULE					
Nozzle Inlet	15	~34.500	~1.0	~2500	Combustion Gas
ENGINE SYSTEM					
Fuel Inlet	13	2.125	18.8	37.8	Hydrogen
Oxidizer Inlet	14	2.125	16.3	162.7	Oxygen
Fuel Pressurization	11	.188	4872	1179	Hydrogen
Oxid Pressurization	12	.250	2576	644	Oxygen

TABLE 34
MODULAR ENGINE INTERFACE
LOCATIONS AND ENVIRONMENTS

Evaluation criteria to judge the concepts were defined. These criteria, given in Table 35, were divided into three main subject areas to help clarify the attributes of the various concepts. Short descriptions of each requirement and evaluation criteria are given below.

Coupling Operation. These criteria relate to assembly/disassembly of the joint on-orbit. These are important considerations with respect to minimizing maintenance costs.

Requirements:

Operable in EVA mode. The coupling must be capable of assembly and disassembly by a suited astronaut or a remotely controlled manipulator in a zero gravity environment.

Safe in EVA mode. Assembly or disassembly of the coupling shall not create a hazard to the operator or equipment.

Locking Mechanism. The coupling must have some form of locking mechanism to prevent thread backoff or other failure mode resulting in loss of joint pre-load.

Evaluation Criteria:

Misalignment accommodation. Coupling concepts were compared with each other, on their ability to handle flange misalignment without degrading coupling reliability.

Required motions for assembly/disassembly. Concepts requiring the least number of motions (i.e. translation, rotation, etc.) were awarded the most points.

Forces required for assembly/disassembly. Concepts requiring the lowest force or torque were awarded the most points.

TABLE 35.
 ADVANCED INTERFACE COUPLING SELECTION

<u>COUPLING OPERATION</u>	<u>REQUIREMENTS</u>	<u>EVALUATION CRITERIA</u>
	OPERABLE AS EVA SAFE FOR EVA LOCKING MECHANISM	MISALIGNMENT ACCOMMODATION OPERATION MOTIONS OPERATION FORCE DAMAGE SENSITIVITY COUPLING VERIFICATION TOOL OPERATING ENVELOPE COUPLING/DECOUPLING TIME NUMBER OF STEPS
<u>PERFORMANCE AT ENGINE OPERATION</u>	SEAL LEAK RATES SEAL LIFE COUPLING LIFE SEALING VERIFICATION PRESSURE RATING TEMPERATURE LIMITS FLUID COMPATIBILITY	SEALING REDUNDANCY SEAL RELIABILITY PRELOAD MECHANISM RELIABILITY VIBRATION/SHOCK SENSITIVITY WEIGHT ENVELOPE
<u>FABRICATION AND MAINTENANCE</u>	LINE SIZE LIMITS NO ROUTINE SERVICING	FABRICATION COST DEVELOPMENT COSTS ADAPTABILITY LIFE CYCLE COST TOOL REQUIREMENTS SPARES INVENTORY

Verification of proper assembly. Concepts were evaluated on the ease of which proper assembly could be determined.

Assembly/disassembly time. Concepts requiring the least amount of time for assembly/disassembly were awarded the most points.

Envelope requirements to operate tools. Concepts that required the smallest envelope to operate assembly/disassembly tools, were awarded the most points.

Damage sensitivity. Concepts were evaluated on the ability to resist damage to the seal, gland, threads, or other coupling elements during assembly/disassembly.

Performance During Engine Operation. This topic addresses the coupling's characteristics when the engine is in service. These criteria are reflected in engine reliability and life issues.

Requirements:

Seal leak rates. The concept must be shown to have leak rates lower than the requirements, at the pressure and temperature expected during use.

Seal Life. The seal element must have a life expectancy (in hours) greater than the requirements, in the working environment.

Coupling life. The coupling must have a life expectancy (in service cycles) greater than the requirements.

Leak detection capability. The concept must be capable of incorporating a leak detection port.

Proof pressure rating. The concept must be capable of being proofed at a pressure 1.5 times the maximum pressure expected during use, without failure.

Temperature limits. The concept must be capable of withstanding the temperature limits expected during use, at the proof pressure.

Fluid compatibility. The materials in contact with the fluid must be compatible with the fluid at the proof pressure, and temperature.

Evaluation Criteria:

Sealing redundancy. If the concept had a backup sealing mechanism, it was awarded five points. Concepts without backup seals received zero points.

Seal reliability. Seal reliability was judged based on experience with the seal in similar applications.

Reliability of pre-load mechanism. An evaluation was made of the concept's loss of pre-load failure modes. Thread backoff, assembly errors, or other causes that could result in failure of the joint, were considered. The most reliable concepts were awarded the most points.

Vibration/shock sensitivity. Concepts were evaluated on their sensitivity to vibration and shock. Concepts that were the least sensitive received the most points.

Weight. Concepts with the lowest overall weight were awarded the most points.

Envelope. Concepts with the smallest overall envelope were awarded the most points.

Fabrication/Development/Maintenance. This subject involves those factors relating to the costs of providing space-operable coupling benefits.

Requirements:

No maintenance required during service cycle. The concept must not require maintenance during the time it is in service.

Fabrication. The concept must be capable of being fabricated in the size required.

Evaluation criteria:

Fabrication or purchase cost. These costs must also include the fabrication or purchase costs of unique-to-joint assembly/disassembly tools. The lowest cost joint concepts were awarded the most points.

Development costs. The development costs must also include the development costs of unique-to-joint assembly/disassembly tools. The lowest cost joint concepts were awarded the most points.

Tool inventory requirements. Concepts requiring the least number of tools for assembly/disassembly were awarded the most points.

Unique-to-joint tool requirements. Concepts that required tools that were not required to service any other component on the OTV received the least points.

Spare parts inventory. Concepts requiring the fewest spare parts, were awarded the most points.

Adaptability to other fluid joint requirements. Concepts that could satisfy the requirements of the greatest number of groups were awarded the most points.

Life cycle costs. Concepts with the lowest life cycle costs were awarded the most points.

An evaluation was developed to assess the concepts applicable to each of the three joint groups. One to five points were awarded to each coupling for each evaluation criteria based on comparison with the competing concepts. Separately, each criteria was assigned a scaling factor to reflect its relative importance with respect to overall goals. The individual points awarded were multiplied by the scaling factors to give evaluation scores for each concept for each criteria. These scores were then summed to indicate overall concept results and relative rankings. The evaluation is shown in Tables 36, 37, and 38 for joint groups I, II, and III respectively.

The results of the evaluation are admittedly somewhat subjective, yet this is inevitable when assessing design concepts. The method used clearly breaks the comparison down to permit identification of subjective scaling factors and point awards and to help force a detailed sense of uniformity throughout. The individual factors or points may be easily changed as new information becomes available. This will arise as engine requirements develop, coupling concepts are further refined, or as additional designs may be identified.

For the high pressure joints, Group I, the spring collar and carriage hook concepts were highest ranking. Because both of these are undeveloped, the small score difference between them should be considered insignificant and they should be viewed with equal promise.

For the small diameter, Group III joints, the Gamah Edge Seal coupling was clearly superior, with the other two scoring low in performance during engine operation.

The study effort concentrated on the Group II joints which are at the vehicle interface locations. This is because, although serviceability benefits are predicted for engine component (modular) replacement features built into the engine design, vehicle contractor study results and initial operating capability require only engine system replacement. Examining the total scores for Group II, it can be seen that the "Carriage Hook" is highest ranking,

TABLE 36.

INTERFACE COUPLING EVALUATION -1

Bracketed items represent scaled Points.

INTERFACE COUPLING DESIGNS					
Evaluation Criteria	Scaling Factor	Spring Collar	Gamah Edge Seal	4 Bolt Flange	Carriage Hook
COUPLING OPERATION					
Misalignment Accommodation	8	4 (32)	3 (24)	2 (16)	5 (40)
Required Motions	9	3 (27)	3 (27)	2 (18)	4 (36)
Required Forces	9	5 (45)	3 (27)	2 (18)	3 (27)
Required Steps	7	4 (28)	2 (14)	1 (7)	4 (28)
Assembly Verification	8	5 (40)	2 (16)	1 (8)	3 (24)
Assembly Time	10	3 (30)	2 (20)	1 (10)	4 (40)
Tool Envelope	5	3 (15)	3 (15)	2 (10)	3 (15)
Damage Sensitivity	6	4 (24)	2 (12)	4 (24)	4 (24)
Subtotal [Perfect Score 40(310)]		31 (241)	20 (155)	15 (111)	30 (234)
PERFORMANCE DURING ENGINE OPERATION					
Sealing Redundancy	3	5 (15)	5 (15)	5 (15)	5 (15)
Sealing Reliability	10	3 (30)	4 (40)	3 (30)	3 (30)
Pre-Load Reliability	9	4 (36)	3 (27)	1 (9)	3 (27)
Vibration Sensitivity	7	4 (28)	2 (14)	2 (14)	2 (14)
Weight	6	4 (24)	2 (12)	2 (12)	3 (18)
Envelope	4	4 (16)	4 (16)	2 (8)	3 (12)
Subtotal [Perfect Score 30(195)]		24 (149)	20 (124)	15 (88)	19 (116)
FABRICATION/DEVELOPMENT/MAINTENANCE					
Fabrication/Purchase costs	6	2 (12)	4 (24)	3 (18)	3 (18)
Development Costs	5	2 (10)	4 (20)	4 (20)	2 (10)
Tool Inventory	2	3 (6)	3 (6)	3 (6)	4 (8)
Adaptability	3	2 (6)	4 (12)	3 (9)	3 (9)
Life Cycle Costs	3	3 (9)	4 (12)	3 (9)	3 (9)
Subtotal [Perfect Score 25(95)]		12 (43)	19 (74)	16 (62)	15 (54)
Total [Perfect Score 95(600)]		67 (433)	59 (353)	46 (261)	64 (404)

TABLE 37.
INTERFACE COUPLING EVALUATIONS -2

Bracketed items represent scaled Points.

INTERFACE COUPLING DESIGNS										
Evaluation Criteria	Scaling Factor	Conoseal V-Band	Gamah Edge Seal	4 Bolt Flange	Carriage Hook	Segmented Thread	Bolted Flange	Spring Collar	Preset Preload	
COUPLING OPERATION										
Misalignment Accommodation	8	4 (32)	3 (24)	2 (16)	5 (40)	3 (24)	2 (16)	4 (32)	3 (24)	
Required Motions	9	3 (27)	3 (27)	2 (18)	4 (36)	3 (27)	1 (9)	3 (27)	3 (27)	
Required Forces	9	1 (9)	3 (27)	2 (18)	3 (27)	3 (27)	2 (18)	4 (36)	4 (36)	
Required Steps	7	3 (21)	2 (14)	1 (7)	4 (28)	3 (21)	0 (0)	3 (21)	3 (21)	
Assembly Verification	8	2 (16)	2 (16)	1 (8)	3 (24)	2 (16)	1 (8)	5 (40)	5 (40)	
Assembly Time	10	4 (40)	2 (20)	1 (10)	4 (40)	3 (30)	0 (0)	3 (30)	3 (30)	
Tool Envelope	5	4 (20)	3 (15)	2 (10)	4 (20)	3 (15)	2 (10)	3 (15)	3 (15)	
Damage Sensitivity	6	3 (18)	2 (12)	4 (24)	4 (24)	2 (12)	4 (24)	4 (24)	3 (18)	
Subtotal [Perfect Score 40(310)]		24 (183)	20 (155)	15 (111)	31 (239)	22 (172)	12 (85)	29 (225)	27 (211)	
PERFORMANCE DURING ENGINE OPERATION										
Sealing Redundancy	3	0 (0)	5 (15)	5 (15)	5 (15)	5 (15)	5 (15)	5 (15)	5 (15)	
Sealing Reliability	10	3 (30)	4 (40)	3 (30)	3 (30)	3 (30)	3 (30)	3 (30)	3 (30)	
Pre-Load Reliability	9	2 (18)	3 (27)	1 (9)	3 (27)	2 (18)	3 (27)	4 (36)	3 (27)	
Vibration Sensitivity	7	2 (14)	2 (14)	2 (14)	2 (14)	2 (14)	2 (14)	4 (28)	2 (14)	
Weight	6	4 (24)	2 (12)	2 (12)	3 (18)	2 (12)	5 (30)	3 (18)	3 (18)	
Envelope	4	3 (12)	4 (16)	2 (8)	3 (12)	4 (16)	3 (12)	3 (12)	4 (16)	
Subtotal [Perfect Score 30(195)]		14 (98)	20 (124)	15 (88)	19 (116)	18 (105)	21 (128)	22 (139)	20 (120)	
FABRICATION/DEVELOPMENT/MAINTENANCE										
Fabrication/Purchase costs	6	4 (24)	4 (24)	3 (18)	3 (18)	3 (18)	4 (24)	2 (12)	2 (12)	
Development Costs	5	4 (20)	4 (20)	4 (20)	3 (15)	3 (15)	5 (25)	2 (10)	2 (10)	
Tool Inventory	2	4 (8)	3 (6)	3 (6)	4 (8)	3 (6)	3 (6)	3 (6)	4 (8)	
Adaptability	3	2 (6)	4 (12)	3 (9)	3 (9)	3 (9)	3 (9)	2 (6)	2 (6)	
Life Cycle Costs	3	4 (12)	4 (12)	3 (9)	3 (9)	4 (12)	2 (6)	3 (9)	3 (9)	
Subtotal [Perfect Score 25(95)]		18 (70)	19 (74)	16 (62)	16 (59)	16 (60)	17 (70)	12 (43)	13 (45)	
Total [Perfect Score 95(600)]		56 (351)	59 (353)	46 (261)	66 (414)	56 (337)	50 (283)	63 (407)	60 (376)	

TABLE 38.
INTERFACE COUPLING EVALUATIONS -3

Bracketed items represent scaled Points.

Evaluation Criteria	INTERFACE COUPLING DESIGNS				
	Scaling Factor	Dynatube	Gamah Edge Seal	Parker Lo-Torque	
COUPLING OPERATION					
Misalignment Accommodation	8	3 (24)	3 (24)	3 (24)	0 (0)
Required Motions	9	3 (27)	3 (27)	3 (27)	0 (0)
Required Forces	9	3 (27)	3 (27)	2 (18)	0 (0)
Required Steps	7	2 (14)	2 (14)	2 (14)	0 (0)
Assembly Verification	8	2 (16)	2 (16)	2 (16)	0 (0)
Assembly Time	10	2 (20)	2 (20)	2 (20)	0 (0)
Tool Envelope	5	3 (15)	3 (15)	3 (15)	0 (0)
Damage Sensitivity	6	1 (6)	2 (12)	1 (6)	0 (0)
Subtotal [Perfect Score 40(310)]		19 (149)	20 (155)	18 (140)	0 (0)
PERFORMANCE DURING ENGINE OPERATION					
Sealing Redundancy	3	0 (0)	5 (15)	0 (0)	0 (0)
Sealing Reliability	10	2 (20)	4 (40)	2 (20)	0 (0)
Pre-Load Reliability	9	2 (18)	3 (27)	2 (18)	0 (0)
Vibration Sensitivity	7	2 (14)	2 (14)	2 (14)	0 (0)
Weight	6	3 (18)	2 (12)	3 (18)	0 (0)
Envelope	4	4 (16)	4 (16)	4 (16)	0 (0)
Subtotal [Perfect Score 30(195)]		13 (86)	20 (124)	13 (86)	0 (0)
FABRICATION/DEVELOPMENT/MAINTENANCE					
Fabrication/Purchase costs	6	4 (24)	4 (24)	4 (24)	0 (0)
Development Costs	5	4 (20)	4 (20)	4 (20)	0 (0)
Tool Inventory	2	3 (6)	3 (6)	3 (6)	0 (0)
Adaptability	3	2 (6)	4 (12)	2 (6)	0 (0)
Life Cycle Costs	3	3 (9)	4 (12)	3 (9)	0 (0)
Subtotal [Perfect Score 25(95)]		16 (65)	19 (74)	16 (65)	0 (0)
Total [Perfect Score 95(600)]		48 (300)	59 (353)	47 (291)	0 (0)

benefiting by providing better misalignment accommodation and simpler coupling operation. The "Spring Collar" design, with a nearly identical score, features better preload reliability and vibration sensitivity. Although both of these concepts require further design and analytical effort to confidently select one as superior, the "Carriage Hook" was chosen as the baseline configuration for the vehicle interface joints. The deciding factor was its advantage over the "Spring Collar" in the fabrication/development/maintenance criteria which were deemed particularly important for near-term program needs.

ENGINE AND COMPONENT DESIGN

Engine System and component designs were identified which depict the requirements and goals defined in the system analysis and maintainability tasks. How these varied and sometimes conflicting needs are resolved was the primary goal of this process. The resulting design concepts, which will continue to evolve as the system is developed, are an attempt to optimally combine the pertinent considerations so as to provide the best means of satisfying the requirements.

The components were resized from the advanced 15K thrust designs for use with the 7.5K thrust engine baselined in this study. The configurations remain essentially unchanged from the 15K designs although some alterations to manifolding, inlets, etc. were necessary because of the scale or to fit the packaging arrangement. Short descriptions of the major components follow.

The High Pressure Fuel Turbopump (HPFTP), Figure 31, is a four-stage centrifugal pump driven by a two-stage partial admission turbine. Operating at just under 200,000 RPM, it supplies liquid hydrogen at 6559 psi outlet pressure.

The High Pressure Oxidizer Turbopump (HPOTP), Figure 32, is a single-stage centrifugal pump driven by a single partial admission turbine. Powered in series with the HPFTP, it supplies liquid oxygen at a 2705 psi outlet pressure.

Low pressure boost pumps supply the needed NPSP to the main pump inlets. The fuel boost pump is powered by a gas turbine operating in parallel with the HPOTP turbine. The oxidizer boost turbine is a full-flow hydraulic type which is powered by the high pressure oxygen provided from the main oxidizer pump.

A 20-inch ribbed combustion chamber is used. The chamber length and contour were selected to obtain the thermal energy needed by the turbines. A full-flow series cooling circuit is used in which the combustor is cooled first in an uppass manner, then the nozzle is cooled in a 1-3/4 pass fashion. This provides the best cooling in the combustor where the heat flux is the

OTV 4-STAGE HPFTP

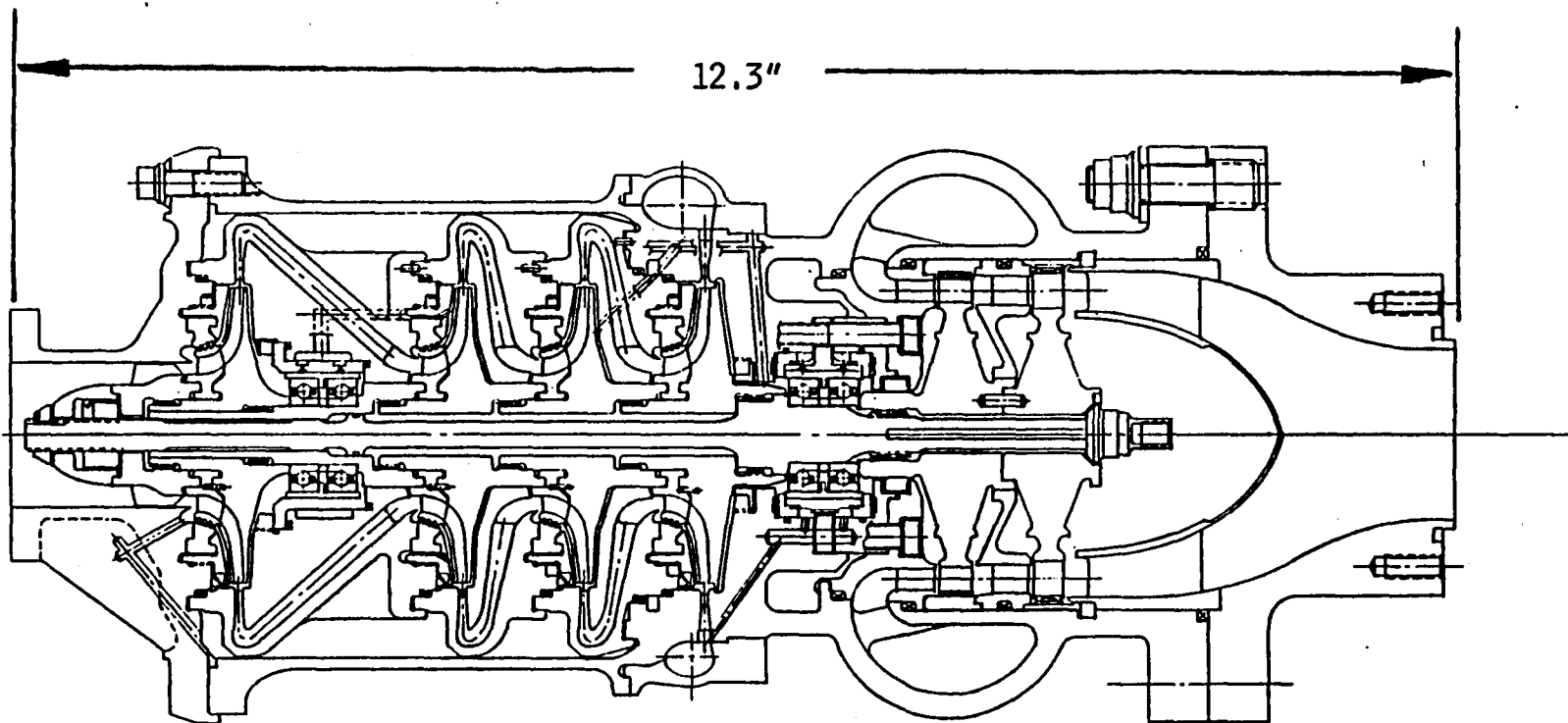

RI/RD86-116

119

- FOUR STAGE CENTRIFUGAL PUMP PRECEDED BY INDUCER WITH AXIAL FLOW INLET
- TWO STAGE PARTIAL ADMISSION, AXIAL, IMPULSE TURBINE WITH SHROUDED BLADES
- HIGH PERFORMANCE EXTENDED GROWTH OTV ENGINE

FIGURE 31.

RI/RD86-116

120

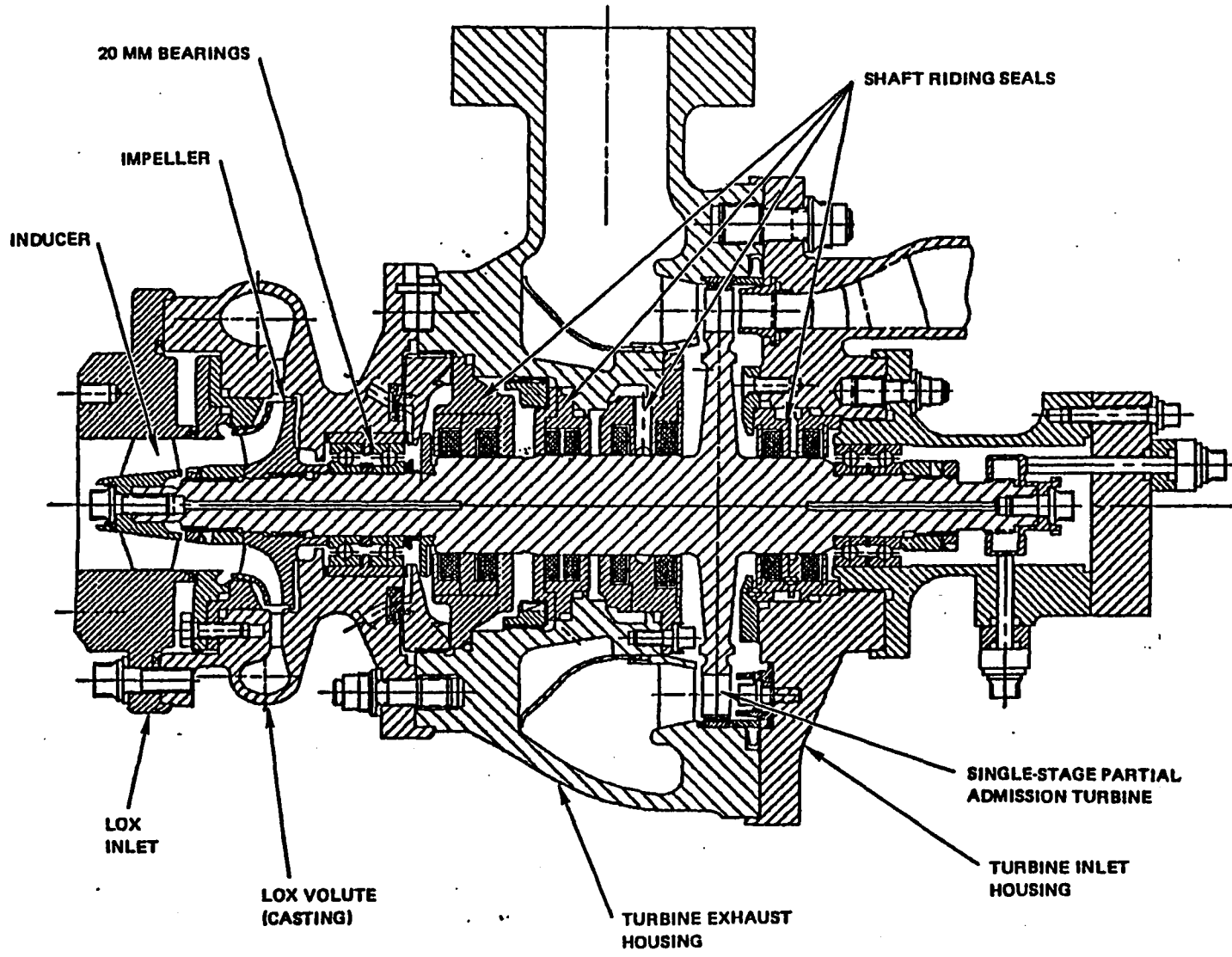

MK 49-0 HPOTP

FIGURE 32.

highest. An extendible, radiation-cooled nozzle is mounted aft of the regeneratively-cooled fixed nozzle to provide an overall expansion ratio of 1080:1. The thrust chamber is shown in Figure 33.

The prototype design of the Main Oxidizer Valve (MOV), which is typical of the primary control valves, is shown in Figure 34. The unit, which is an electric ballscrew actuated sector valve, is compact and of relatively simple design. The entire ball, shaft, and actuator mechanism can be removed as a unit with the separation of one coupling. This leaves only the housing, which is welded to the duct, and the ball seal remaining on the installation. The ball seal can then be removed through the resulting open port.

These components were packaged into an arrangement which reflects the system analysis and maintainability task results. The system definition given by the systems trades was divided into modules as depicted schematically in Figure 35. The baseline grouping of components was based on general life and reliability data in conjunction with weight and maintenance task time considerations. This configuration places the turbopumps and primary valves into sub-engine, space-replaceable units. This results in a Fuel Module and Oxidizer Module which can be replaced. A third Core Module requires engine removal from the vehicle for replacement. The Controller Module and Nozzle Module are also space-replaceable without engine removal.

It should be noted that this engine division is not the only modular package possible. Other arrangements can group components to reflect the maintainability goals of the program. The major limit to possible options available is the weight and physical system arrangement problems involved when groups of components are to be removed as units.

Four modularity options were identified. These are listed in Table 39. Option A is similar to the baseline but incorporates the regenerator, LOX heat exchangers, GOV, and TSV into a larger fuel module. Option B is grouped to include these same components into the oxidizer module, rather than the fuel module. Option C uses a new Valve Module containing all of the electrically

THRUST CHAMBER ASSEMBLY

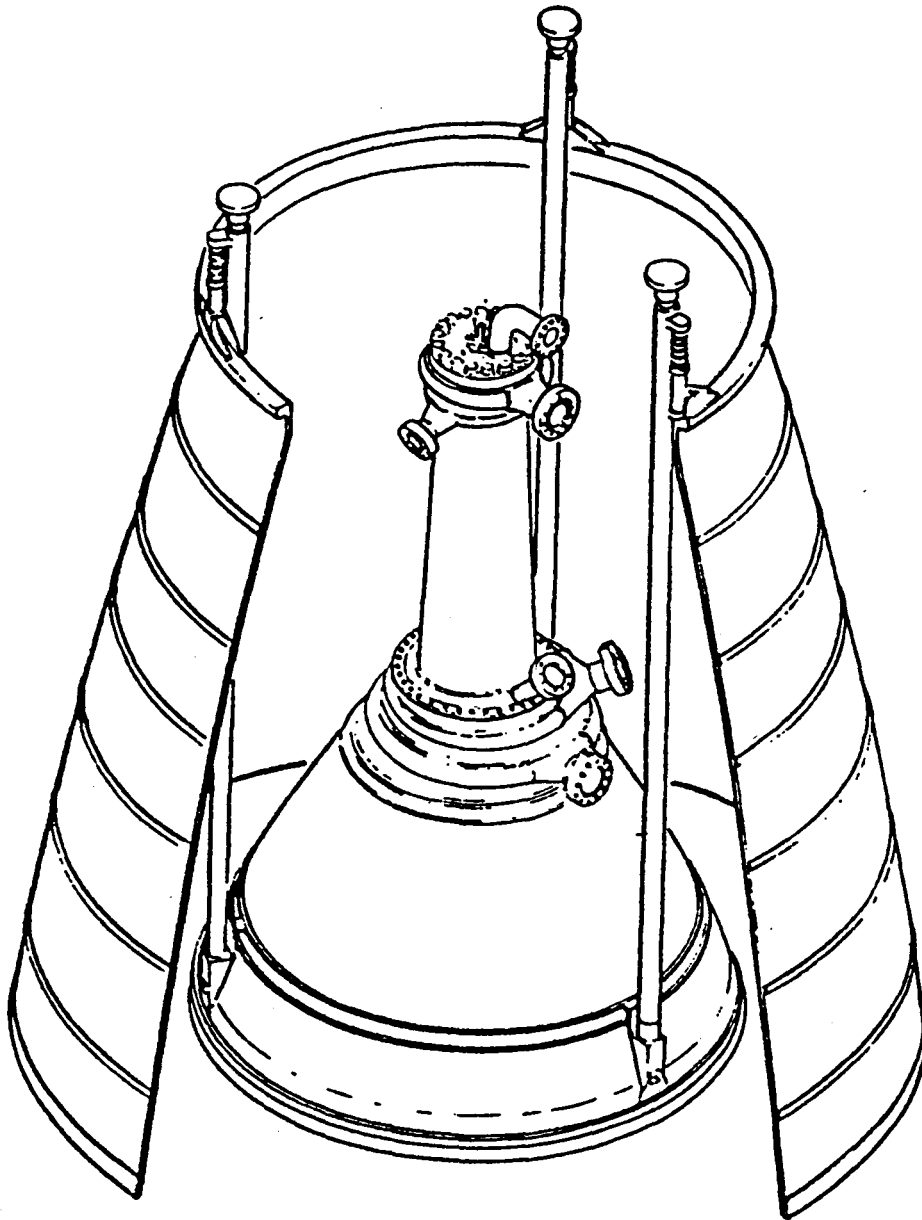
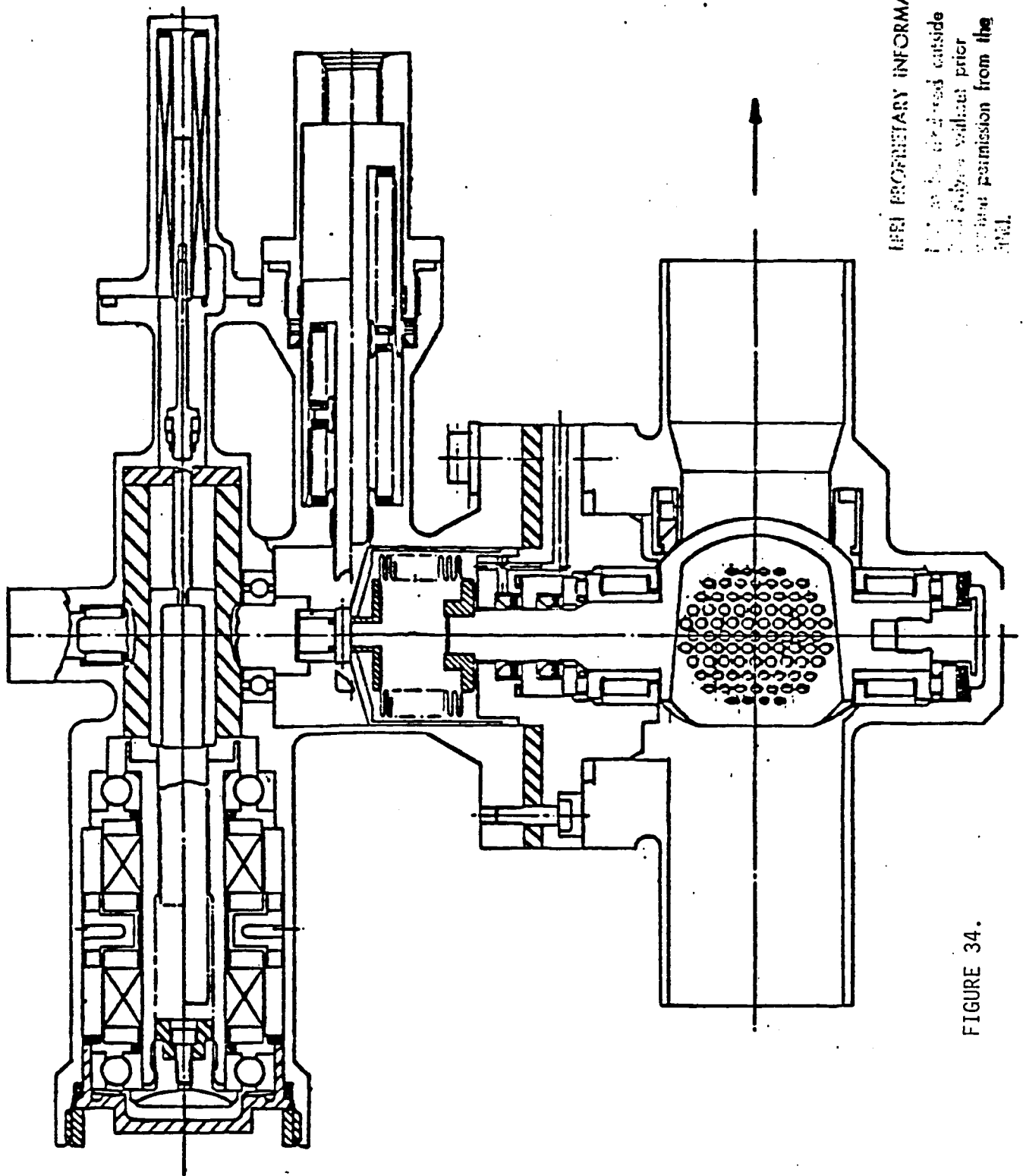

FIGURE 33.

FLIGHT WEIGHT ELECTRIC ACTUATED VALVE



IBM PROPRIETARY INFORMATION
Not to be released outside
IBM Corp. without prior
written permission from the
IBM.

FIGURE 34.

MODULAR OTV ENGINE-SCHEMATIC

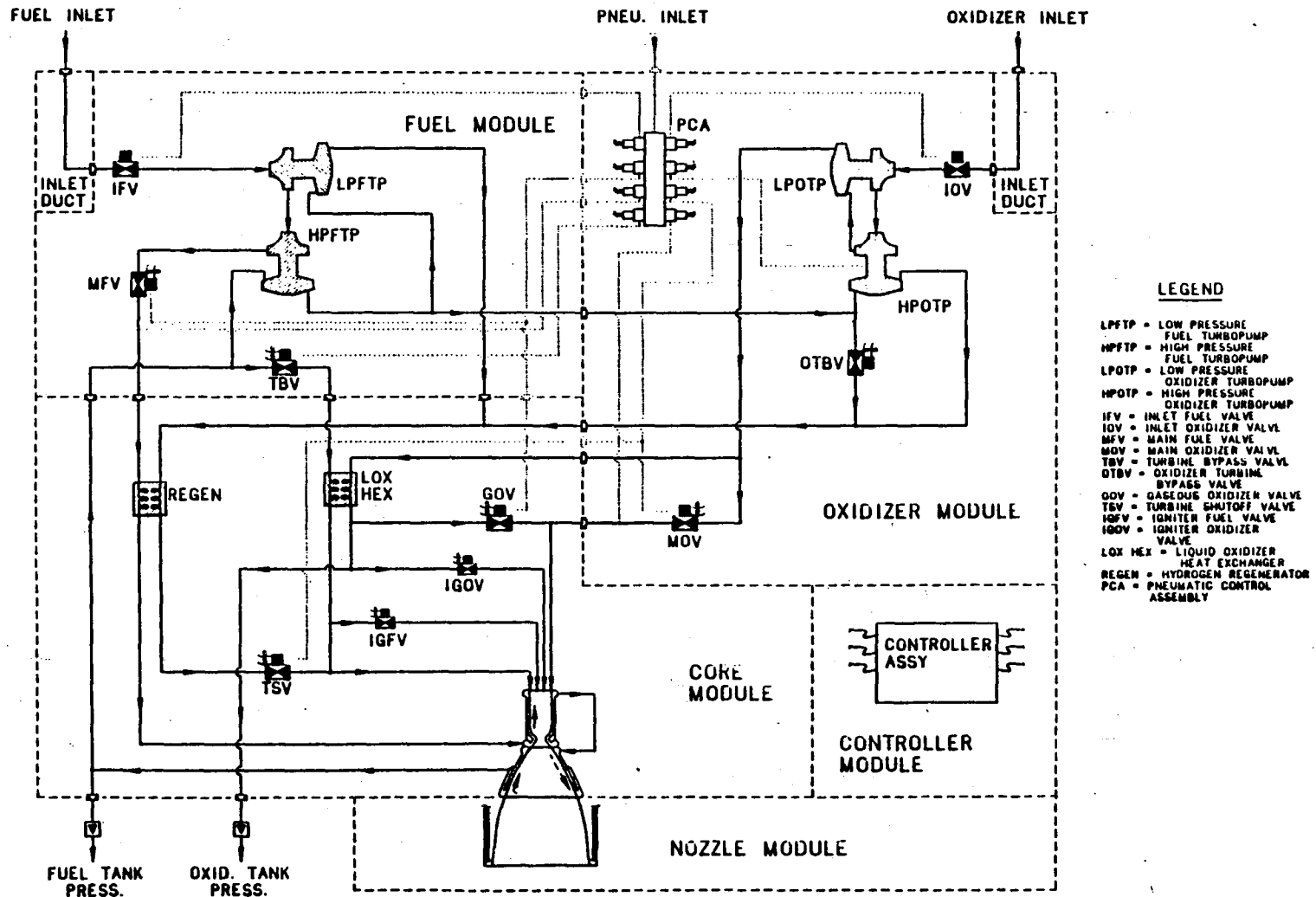

RI/RD86-116
 124

491-128

FIGURE 35.

TABLE 39. ENGINE MODULARITY OPTIONS

<u>Number of Interfaces</u>	<u>Baseline</u>	<u>Option A</u>	<u>Option B</u>	<u>Option C</u>	<u>Option D</u>
Oxidizer Module	5	6	10	4	4
Fuel Module	6	12	6	5	5
Chamber Module	9	6	6	6	5
Valve Module	DNA	DNA	DNA	13	12
Pneumatics	7	6	5	3	3
TOTAL*	19	20	18	19	18
Approx. Wt. Penalty (lb)	Baseline	1.5	1.0	3.5	3.0

*Total is unique total rather than sum of column.

actuated valves, igniter valves, and the two heat exchangers. The fuel and oxidizer modules each contain their respective turbopumps and inlet valve. Option D is very similar to Option C, except that the igniter valves are included in the Chamber Module.

Although the weight penalties are relatively small for these options and each provides additional replacement capability, they share a number of disadvantages over the baseline case. Primarily, one module in each option requires a large number of joints to be disconnected/connected during replacement. Space task times would greatly increase. Also, although the total number of interfaces is essentially the same, Options C and D contain more propellant interfaces which are inherently less tolerant of joint failure.

Because of these disadvantages, it is felt that the baseline selection is best. It appears to be an optimum compromise between engine reliability and space maintainability. The design of the GOV and TSV permits space replacement of the ball/actuator, should this be a space maintenance concern. Alternately, the GOV can be placed in the oxidizer module with one additional interconnect and the TSV can be placed upstream of the high pressure fuel turbine. These are small modifications of the baseline grouping which involves other issues, such as valve consolidation, which will be evaluated in the following tasks.

A layout of the baseline modular engine is shown in Figure 36. The overall length of the engine during operation is 117 inches, with a one-piece extendible radiation-cooled nozzle permitting a stowed engine length of 60 inches. A stowed length of 40 inches would be possible by using three extendible sections of 15, 28, and 34 inches in length. Because the top 15 inch section must be regeneratively cooled, the high pressure flexible lines required and added complexity of three moving nozzle sections makes this option very unattractive from an engine point of view. An engine weight breakdown is presented in Table 40.

REV	DATE	DESCRIPTION
1		ISSUED FOR CONSTRUCTION
2		ISSUED FOR CONSTRUCTION
3		ISSUED FOR CONSTRUCTION
4		ISSUED FOR CONSTRUCTION
5		ISSUED FOR CONSTRUCTION
6		ISSUED FOR CONSTRUCTION
7		ISSUED FOR CONSTRUCTION
8		ISSUED FOR CONSTRUCTION
9		ISSUED FOR CONSTRUCTION
10		ISSUED FOR CONSTRUCTION
11		ISSUED FOR CONSTRUCTION
12		ISSUED FOR CONSTRUCTION
13		ISSUED FOR CONSTRUCTION
14		ISSUED FOR CONSTRUCTION
15		ISSUED FOR CONSTRUCTION
16		ISSUED FOR CONSTRUCTION
17		ISSUED FOR CONSTRUCTION
18		ISSUED FOR CONSTRUCTION
19		ISSUED FOR CONSTRUCTION
20		ISSUED FOR CONSTRUCTION
21		ISSUED FOR CONSTRUCTION
22		ISSUED FOR CONSTRUCTION
23		ISSUED FOR CONSTRUCTION
24		ISSUED FOR CONSTRUCTION

127

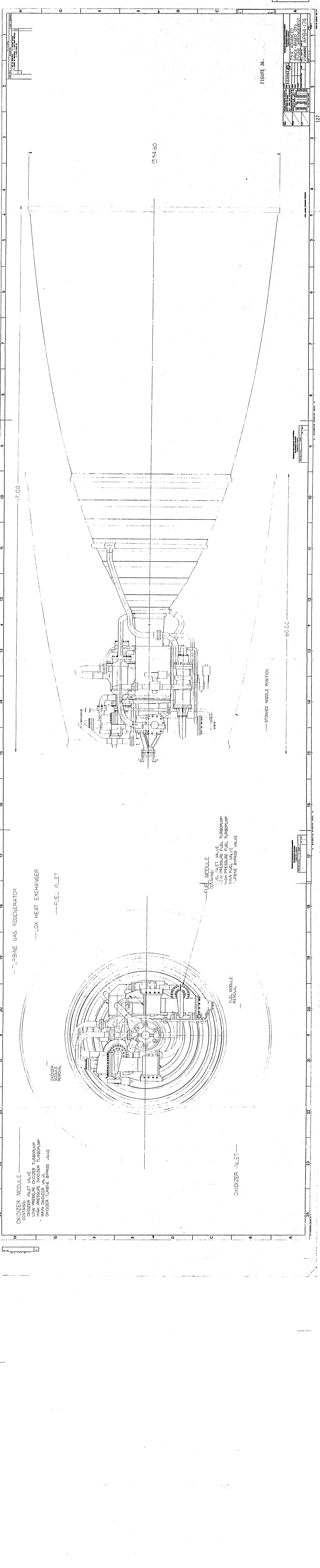
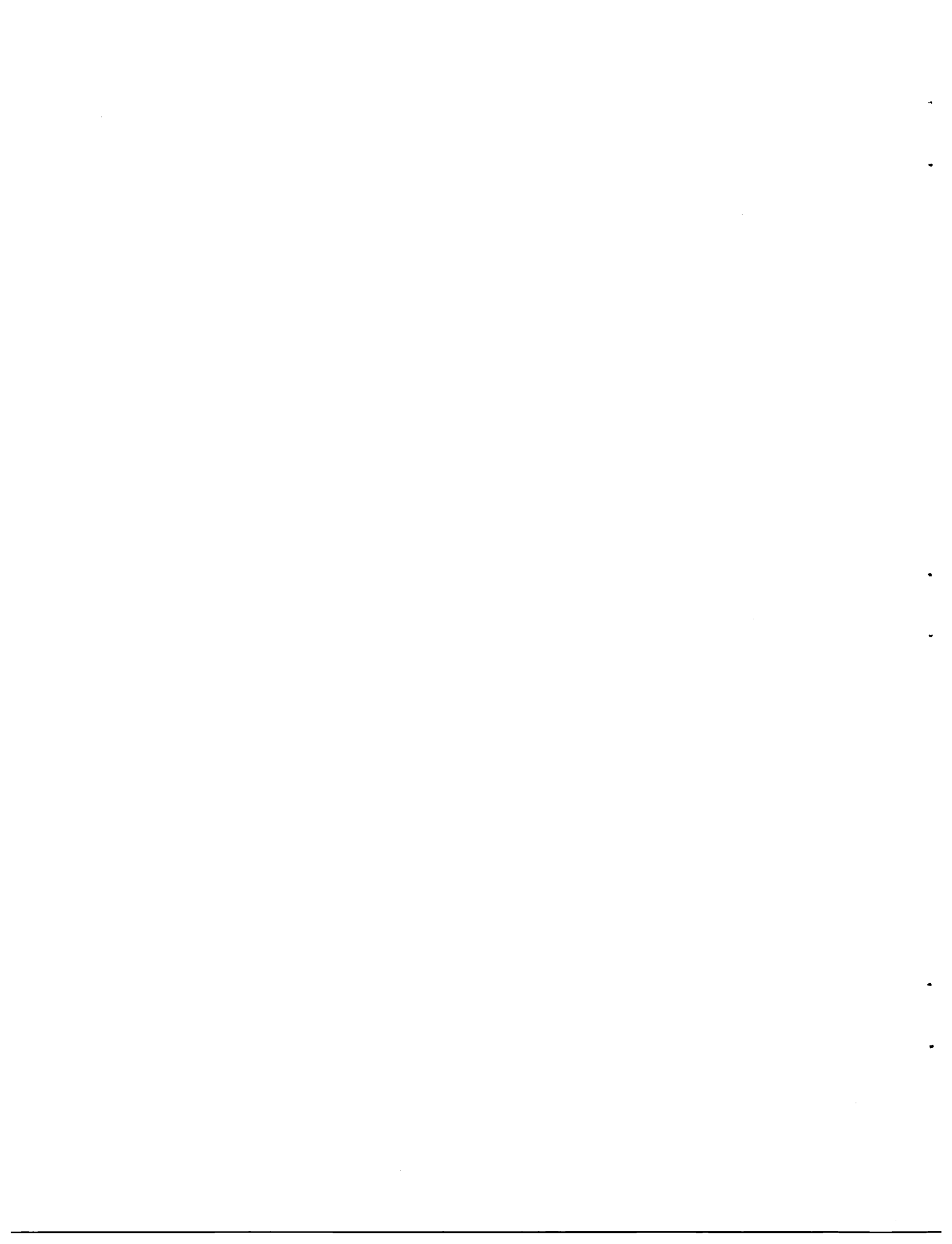

FIGURE 36.

TABLE 40.
ADVANCED OTV ENGINE WEIGHTS

Thrust		= 7500 lb		
Chamber Pressure		= 1576 psi		
Nozzle Area Ratio		= 970:1		
Turbopumps	(L.P.)	(H.P.)		50.4
Fuel	3.2	25.1	28.3	
Oxid.	5.0	17.1	22.1	
Gimbal Assembly				1.3
Thrust Chambers				151.3
Injector			3.5	
Combustion Chamber			30.1	
Fixed Nozzle			61.6	
Extendible Nozzle			56.1	
Valves & Controls				17.9
Propellant Valves			11.2	
Control Valves			1.8	
Controller Assembly			0	
Harnesses & Sensors			4.9	
Engine Systems				33.0
Propellant Ducting			3.6	
Extendible Nozzle Mechanism			14.9	
Interface Lines			.8	
Pneumatic Control Lines			0	
Ignition System			3.1	
Heat Exchanger			10.6	
H ₂ Regenerator			0	
TOTAL				253.9



The T-mounted pump configuration, with each boost pump attached directly to its associated high pressure pump, has been retained from the 15K engine design. These assemblies have been rotated so that the high pressure pumps are parallel to the engine axis. The engine center of gravity is raised, thus lowering gimbal moments, while still providing a long, straight, uniform flow to the boost pump inlets for low NPSH capability.

As noted above, the components are arranged into three primary modules. The Fuel Module contains the fuel inlet valve, low pressure fuel turbopump, high pressure fuel turbopump, main fuel valve, and turbine bypass valve. The Oxidizer Module, placed on the opposite side of the engine, contains the oxidizer inlet valve, low pressure oxidizer turbopump, high pressure oxidizer turbopump, main oxidizer valve, and oxidizer turbine bypass valve. The interfaces between each of these modules and the rest of the engine are such that once disconnected, either module maybe removed in a single-direction motion. The thrust chamber, gimbal, regenerator, and oxygen heat exchanger from the third or Core Module. The extendible nozzle with its drive mechanism and the engine Control and Health Monitoring System (ICHM) constitutes the two additional space-replaceable modules.

It should be noted that the modularity which has been incorporated into this design has extracted very little penalty over an arrangement where this feature was not considered. Relative component placement is consistent with optimal system performance and system ducting is not unusually configured or contributing to abnormally high head losses. This result demonstrates the fact that, when considered early in the design process, system maintainability can be favorably tailored to meet desired goals without sacrificing system performance. Whether or not maintainability features are to be fully used initially, by applying these considerations to the initial design, future growth versions can take advantage of them with much less effort than would be needed if maintainability was de-emphasized at this stage of development.

One potential penalty of space maintainable design is the additional weight results from providing this capability. For the maintenance philosophy and packaging design initially baselined in this study, the weight penalty is

primarily manifested in the number of space-separable interface joints required (which is influenced by how modules are selected) and the design of the interfaces themselves. It should be noted that separable joints are required on the engine to permit ground maintenance and, in some cases, to allow engine assembly where welding is not practical for material or precision tolerance considerations. Therefore, the weight penalty resulting from space maintenance is the additional weight above the required for these minimally required joints.

To determine this additional weight, the weight of the minimally required joints was first estimated. Because they need not be easily space-separable, these joints were assumed to be bolted flange designs optimally configured for low weight. This resulted in joints using 8-10 bolts, depending on line size, pressure, and temperature.

Weights were then estimated, based on the same type of optimally designed joints, for the three additional interfaces required of the initial space-based modular engine arrangements. The resulting 1.4 pound increase represents the penalty of providing an engine with modular maintenance capability at a ground base or when EVA astronauts could cope with the large number of fasteners. Grouping of components into other modular arrangements can either increase or decrease this result.

To ease the EVA effort required of bolted joints, a minimum number of fasteners is desired. To investigate the consequences of this, interface weights were estimated for the modular engine case with only four bolts per joint allowed. From a joint design viewpoint, this results in larger flange thicknesses (again depending on line size, pressure, and temperature) which increase the total joint weight 7.88 pounds. The weights discussed are summarized in Table 41. The higher ranking interface concepts evaluated for modular space maintenance are expected to possess slightly lower weight penalty effects compared to the four-bolt flange case presented.

TABLE 41.

WEIGHT EFFECTS OF SPACE MAINTAINABLE INTERFACES

JOINT NO.	JOINT WEIGHTS (LB)		
	OPTIMUM (8-10) BOLTS		FOUR BOLTS MODULE
	MINIMUM	MODULE	
1	.65	.65	.94
2	.87	.87	1.73
3	1.17	1.17	2.23
4	—	.52	.99
5	.06	.06	.06
6	1.44	1.44	2.75
7	1.44	1.44	2.75
8	.65	.65	.94
9	—	.04	.04
10	—	.87	1.73
TOTAL	6.28	7.71	14.16
PENALTY OVER MINIMUM	—	1.43	7.88

131
RI/RD86-116

491-147



Rockwell
International
Rocketdyne Division

ADVANCED ENGINE CONCEPTS

Outputs from the various studies and reviews conducted (engine operation studies, FMEA/reliability review, maintainability studies, etc.) were then used to develop advanced engine concepts which are to be incorporated into the baseline engine. The approach taken was to first generate a comprehensive list of innovative concepts in which feasibility was not initially stressed. These ideas were then reviewed by the respective component groups to assess feasibility and potential for further development. A tabulation of these concepts is provided in Table 42. The status of each concept (to be used, rejected, or yet to be evaluated) is indicated and additional comments delineating benefits, reasons for rejection, and technology issues are included. Several of the concepts, particularly in the advanced sensor category, have yet to be evaluated and will be addressed in the next phase of the ICHM task. Technology plan numbers were assigned to the promising concepts and correspond to the development plan summaries generated under the Technology Assessment and Planning task.

TABLE 42.
INNOVATIVE CONCEPTS LIST

CONCEPT	STATUS		COMMENTS	TECHNOLOGY PLAN NUMBER
	TO BE USED	TO BE REJECTED EVALUATED		
1. <u>Turbine Shutoff Valve (TSV)</u> . This valve, if required, would be placed either upstream or downstream of the H ₂ high pressure turbine.	X		Eliminates need for pump brakes (tank head) idle), quick pump speed decay on shutdown minimizes time at damaging critical speeds, may be consolidated (see below).	1
2. <u>TSV/TBV</u> . TSV and turbine bypass valve (TBV) combined - The TSV and TBV can be combined into one 2-way valve such that upon engine shutdown the valve diverts the H ₂ flow from the main fuel turbine to the combustion chamber.	X		Weight savings and reliability improvement, preliminary design and sketches generated.	2
3. <u>TSV/TBV/MFV</u> . TSV, TBV and main fuel valve (MFV) combined - The TSV, TBV, and MFV can be combined into one valve. Similar to the case above but with an additional valve positioning for complete shutoff to turbine and combustion chamber.		X	Thermal management problem (LH ₂ & HOT GH ₂ in same vicinity), hermetic seal required for MFV.	DNA
4. <u>MOV/GOV</u> . Main oxidizer valve (MOV) and gaseous oxidizer valve (GOV) combined - The MOV and GOV can be combined into one 3-way valve that would divert LOX between injector or heat exchanger (HEX) or shut O ₂ flow off completely. Ideally of very similar design to combined MFV/TBV/TSV above.	X		Weight savings and reliability improvement, design same as for TSV/TBV consolidation.	3
5. <u>Redundant Valve Actuators</u> . For variable position in addition to on/off for fail-operational capability.		X	Complex planetary gear drive requiring extensive costly development.	DNA

TABLE 42.
INNOVATIVE CONCEPTS LIST (CONTINUED)

CONCEPT	STATUS			COMMENTS	TECHNOLOGY PLAN NUMBER
	TO BE USED	REJECTED	TO BE EVALUATED		
6. <u>Cartridge Valves</u> . Valve internal parts in modular cartridge.	X			Weight savings with body welded in line eliminating flanges. Quick replacement of cartridges.	4
7. <u>Igniter</u> . Consolidated/modular package mounted for easy access (removal, servicing, replacement).	X			For space based maintenance, preliminary design and sketches generated.	5
<u>Zero or Minimum Purge</u>					
8. Advanced seals requiring no inter-propellant purges.			X	Elimination of helium tankage provides weight savings, and simplified plumbing.	Not Assigned yet
9. No purging of systems on engine shutdown.			X		"
10. Use of GH ₂ for pneumatics.			X		"
11. <u>Composite Materials</u> . Engine weight reduction through extensive use of metal matrix composite (MMC) materials.			X	24% weight savings realizable.	6
12. <u>Multiplexed Control & Power</u> . Combining of control and power harnesses.			X	Single simplified harness.	Not assigned yet
<u>Controller Packaging</u>					
13. Distributed Electronics near components/sensors.			X	To be evaluated by ICHM group.	"
14. Single controller on vehicle for engine pair (2 x 7.5K).			X	" " "	"
<u>Extendible Nozzle - retractable nozzle for shuttle bay storage and aerobrake maneuvering</u>					
15. Mechanical retraction/extension devices.	X			Several preliminary designs exist.	7

RI/RD86-116
134

TABLE 42.
INNOVATIVE CONCEPTS LIST (CONTINUED)

CONCEPT	STATUS		COMMENTS	TECHNOLOGY PLAN NUMBER
	TO BE USED	TO BE REJECTED EVALUATED		
16. Coolant fluid interconnects.	X		Remote high pressure hermetic seal.	8
17. Nozzle segment interface seals.	X		Interface between cooled and carbon 9 /carbon radiation nozzle segment.	
18. Space operable fluid disconnects.	X		Enables space based maintenance (quick simple component replacement).	10
19. <u>Holographic leak detection.</u> For quick leak detection post maintenance/preflight.			No on-engine sensors, must establish viewing requirements.	not assigned yet
<p><u>Sensor & Diagnostic System.</u> Strategically placed lasers in space station bay with remote/robotic sensors (optical interferometers).</p> <p>Installation requirements for component design: "Clear-view" of critical fluid interconnects and leak susceptible components.</p>				
20. <u>Isotopic wear detection.</u> For monitoring bearing, seal, components wear - replaces routine disassemblies/inspections.			Required engine components not yet established, access believed to be adequate with the current design. Will be checked using ground based sensor envelopes.	"
<p>Sensor & Diagnostic System: Remote/robotic geiger counter-type, radiation sensor and computer diagnostic system for recording of life histories and comparison to wear limits - space station bay.</p>				

RI/RD86-116

135

TABLE 42.
INNOVATIVE CONCEPTS LIST (CONTINUED)

CONCEPT	STATUS			COMMENTS	TECHNOLOGY PLAN NUMBER
	TO BE USED	REJECTED	TO BE EVALUATED		
Installation requirements for component design: wear susceptible components (bearings, seals, etc.) surface doped with radioactive isotope tracer - component clearances must be considered to allow sensor access.					
21. <u>Exoelectron fatigue detection.</u> For monitoring fatigue of critical components and life predictions for replacement/repair schedule.			X	Typically no inflight sensors are used. Because no requirements have been specified, it is not planned to be shown on the engine update.	not assigned yet
Sensor & Diagnostic System: UV light source and exoelectron detector on remote/robotics and computer diagnostics for data analysis, life history recording, and component life predictions - space station bay.					
Installation requirements for component design: surfaces of fatigue susceptible components should be accessible to sensors.					
22. <u>Optical Deflectometer.</u> For detection of turbo-machinery bearing wear and incipient failure.			X	Design update will depict a conceptual installation of these sensors.	"
Sensor & Diagnostic System: Fiber optic sensors relaying data to computer in flight for recording of life histories and comparison to allowable wear limits.					
Installation requirements for component design: Ports for sensors and fiber optics required in turbopump housings.					

RI/RD86-116

136

0485E

TABLE 42.
INNOVATIVE CONCEPTS LIST (CONTINUED)

CONCEPT	STATUS		COMMENTS	TECHNOLOGY PLAN NUMBER	
	TO BE USED	TO BE REJECTED EVALUATED			
<p>23. <u>Optic Pyrometer</u>. Monitor turbine blade tip temperatures for overtemps and excessive heating rates during thermal transients.</p> <p>Sensor & Diagnostic Systems: Optical pyrometers relaying thermal data to computer diagnostics for recording life histories and comparison to allowable temp limits.</p> <p>Installation requirements for component design: Ports in turbine housings for sensors and fiber optics required.</p>		X	Relatively low turbine blade temperatures in expander cycle reduce possibility of employing this device. Therefore, it will not be depicted on engine update.	not assigned yet	
<p>24. <u>Spectrometer</u>. For exhaust gas analysis.</p> <p>Sensor & Diagnostic Systems: flame spectroscopy optical sensor(s), wave signal analyzer, and computer for data reduction, analysis, and comparison.</p> <p>Installation requirements for component design: sensor penetration exhaust nozzle possibly cooled with regenerative coolant, signal transmission lines back up to processor.</p>			X	Conceptual installation will be depicted on engine design update.	"
<p>25. <u>Torquemeter</u>. To detect bearing wear, seal rub, and blade/impeller to housing rub on turbomachinery.</p> <p>Sensor & Diagnostic Systems: magnetic strips on turbopump shafts, sensors linked to computer diagnostics for recording of life histories and comparison to normal torque values.</p>			X	Conceptual installation will be depicted on engine design update.	"

RI/RD86-116

137

TABLE 42.
INNOVATIVE CONCEPTS LIST (CONTINUED)

CONCEPT	STATUS		COMMENTS	TECHNOLOGY PLAN NUMBER
	TO BE USED	TO BE REJECTED EVALUATED		
Installation requirements for component design: magnetic strips incorporated in shaft manufacture, sensor port for view of shaft in-housing.				Not Assigned yet
26. <u>Optical Scanning Pyrometer.</u> For detection of restrictions or defects in regenerative cooling circuits - coolant flowed through passages while surface temperatures are monitored remotely with scanning pyrometer.		X	No on-engine sensors required, access to chamber coolant passages is sufficient from inside of chamber.	"
Sensor & Diagnostic System: remote/robotic scanner in space station bay.				
Installation requirements for component design: visibility of critical coolant passages.				
27. <u>Fiberoptic Tachometer.</u> For RPM of turbo-machinery, non-intrusive, lightweight stripes on shafts with optic sensor measuring RPM.		X	Conceptual installation will be depicted on engine design update.	"
Sensor & Diagnostic System: fiber optic sensor relaying data to computer in flight for recording and for detection of overspin.				
Installation requirements for component design: sensor ports and view of shafts in housings.				
28. <u>Acoustic-Optical Fatigue.</u> Laser induced ultrasonic defect mapping for fatigue analyses.		X	No on-engine sensors required.	"

0485E

RI/RD86-116

138

TABLE 42.
 INNOVATIVE CONCEPTS LIST (CONTINUED)

CONCEPT	STATUS			COMMENTS	TECHNOLOGY PLAN NUMBER.
	TO BE USED	REJECTED	TO BE EVALUATED		
Sensor & Diagnostic System: remote/robotic laser source/sensor in space station bay coupled to computer to record component fatigue history for determination of servicing requirements.					Not Assigned yet
Installation requirements for component design: visibility of critical fatigue susceptible components/access for laser source/sensors.					

R1/RD86-116

139

ENGINE DESIGN UPDATE

The engine system design was updated to reflect the results of the study effort. Notably, vehicle interface couplings, a dual igniter module, and ICHM requirements were added. The updated layout is shown in Figure 37. No significant component design changes arose during the course of the study except for the igniter, which is discussed below. Flanges permitting modular maintenance were removed to show the configuration which complies with the current preference of the vehicle contractors for engine-only replacement. However, some flanges remain due to fabrication and assembly needs. The packaging and line arrangement was not altered so that a system which could grow into a more serviceable configuration with simply the addition of space-operable couplings is depicted. No significant advantage was seen in changing the arrangement in a manner which would lose this growth potential.

The baseline engine design, although not specifically detailed, assumed that the igniter chamber/spark plug assembly is axially installed atop the injector with the other components mounted near it on the injector or thrust mount structure. This arrangement does not lend itself readily to space maintenance because of the number of separate components involved and the limited access available under the thrust mount. This ignition system consists of the igniter chamber, igniter valves (one each oxidizer and fuel), two spark plugs, two spark exciters, and associated instrumentation. In keeping with the notion of a modular engine packaging philosophy, the individual igniter components were examined to determine how they could be packaged into a single, space replaceable unit. It was found that this could be accomplished by mounting the igniter chamber perpendicular to the engine axis. The igniter coolant channels would be part of this unit rather than partially contained in the injector housing, as is typical. The spark plugs and exciters would be welded to the igniter chamber to reduce the number of seals. The igniter valves and instrumentation, with all welded lines, would complete the igniter module assembly.

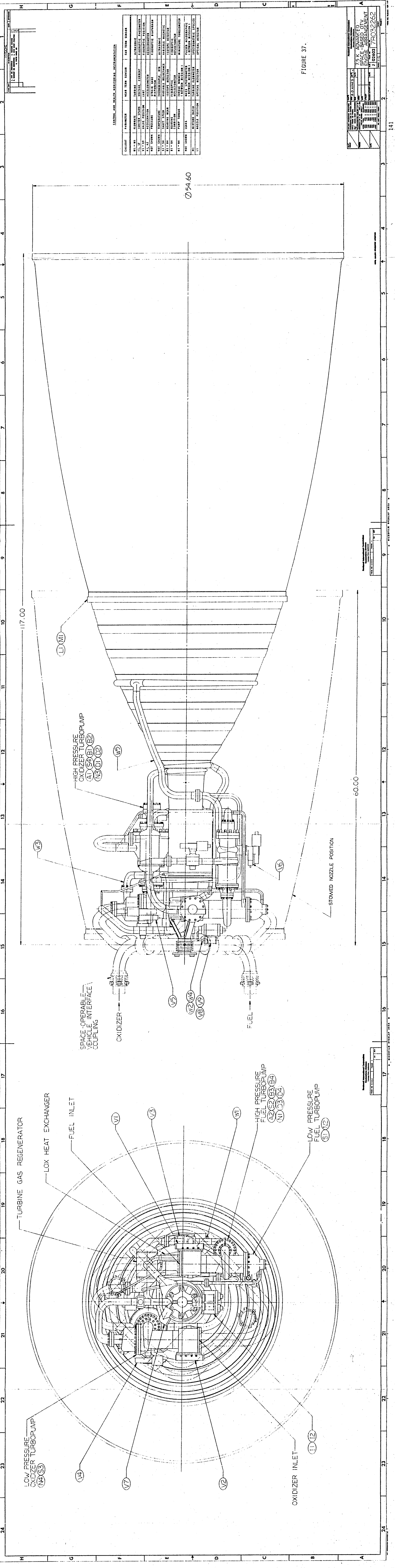

CONTENTS AND HEALTH MONITORING INSTRUMENTATION

CALLOUT	PARAMETER	HEALTH MONITORING INSTRUMENTATION
V1	TEMPERATURE	TEMPERATURE
V2	TEMPERATURE	TEMPERATURE
V3	TEMPERATURE	TEMPERATURE
V4	TEMPERATURE	TEMPERATURE
V5	TEMPERATURE	TEMPERATURE
V6	TEMPERATURE	TEMPERATURE
V7	TEMPERATURE	TEMPERATURE
V8	TEMPERATURE	TEMPERATURE
V9	TEMPERATURE	TEMPERATURE
V10	TEMPERATURE	TEMPERATURE
V11	TEMPERATURE	TEMPERATURE
V12	TEMPERATURE	TEMPERATURE
V13	TEMPERATURE	TEMPERATURE
V14	TEMPERATURE	TEMPERATURE
V15	TEMPERATURE	TEMPERATURE
V16	TEMPERATURE	TEMPERATURE
V17	TEMPERATURE	TEMPERATURE
V18	TEMPERATURE	TEMPERATURE
V19	TEMPERATURE	TEMPERATURE
V20	TEMPERATURE	TEMPERATURE
V21	TEMPERATURE	TEMPERATURE
V22	TEMPERATURE	TEMPERATURE
V23	TEMPERATURE	TEMPERATURE
V24	TEMPERATURE	TEMPERATURE
S1	TEMPERATURE	TEMPERATURE
S2	TEMPERATURE	TEMPERATURE
S3	TEMPERATURE	TEMPERATURE
N1	TEMPERATURE	TEMPERATURE
N2	TEMPERATURE	TEMPERATURE
N3	TEMPERATURE	TEMPERATURE
N4	TEMPERATURE	TEMPERATURE
M1	TEMPERATURE	TEMPERATURE

FIGURE 37.

70-15-145-03
 SPACE-BASED TV
 ENGINE ARRANGEMENT

NO.	REV.	DATE	BY	CHKD.
1	01	11/03/60		
2	02			
3	03			
4	04			
5	05			

1100000 17032262

This modular igniter concept is shown in Figure 38. The unit is mounted perpendicular to the longitudinal axis of the engine so that it may be removed radially without disturbing the gimbal/thrust mount structure installation. For clarity, a disconnect coupling for this concept is not shown.

Replacement of this unit would first require disconnecting the igniter valve inlet lines and a multipin electrical coupling. A single fluid coupling would then be actuated to disconnect the assembly from the injector. This coupling would both serve as a fluid joint for the igniter combustion and coolant flows and as a structural attachment for the igniter module. Advanced fluid coupling concepts examined for use as duct joints would also be applicable for this module. A comparison of features between the modular and baseline igniter systems is shown in Table 43.

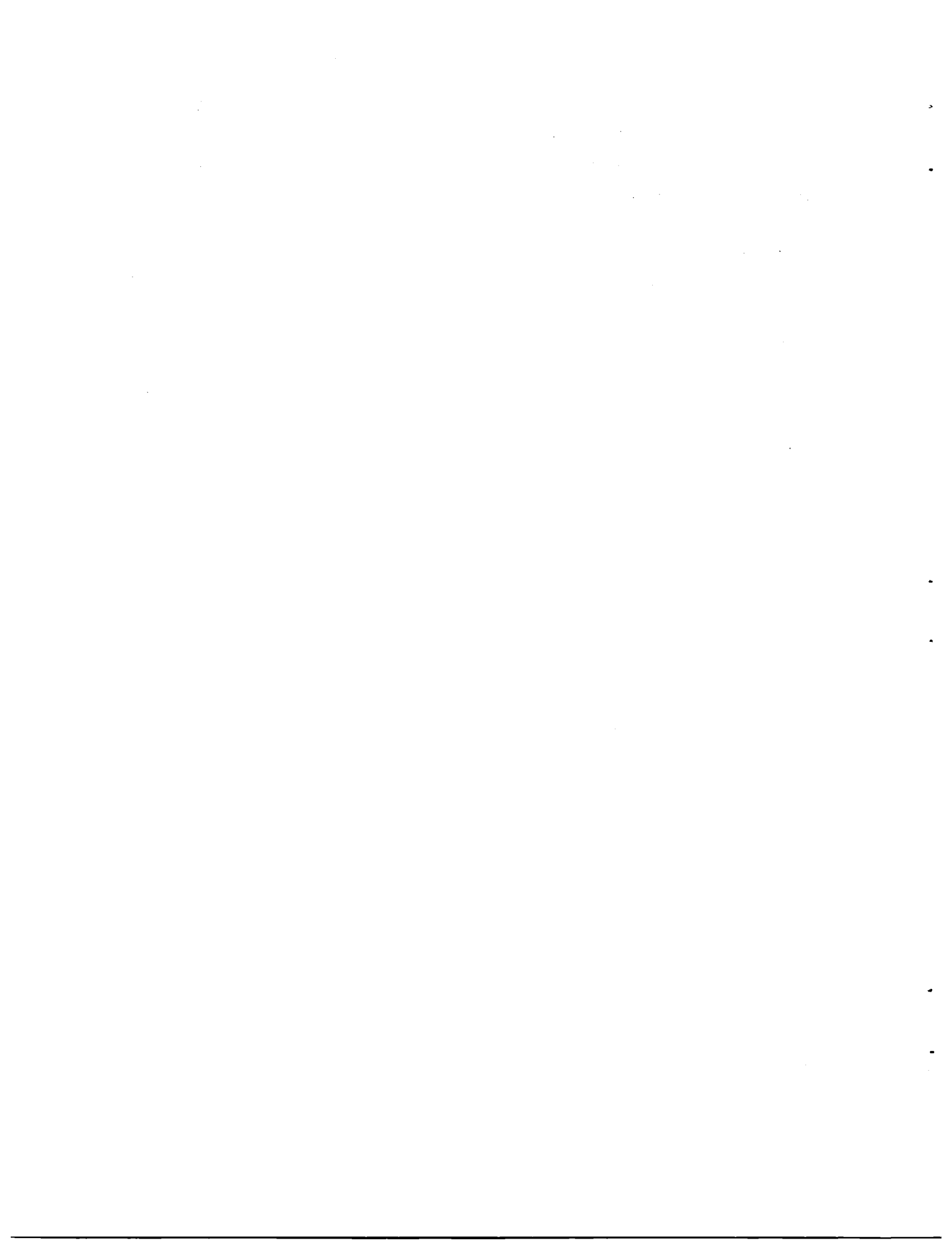

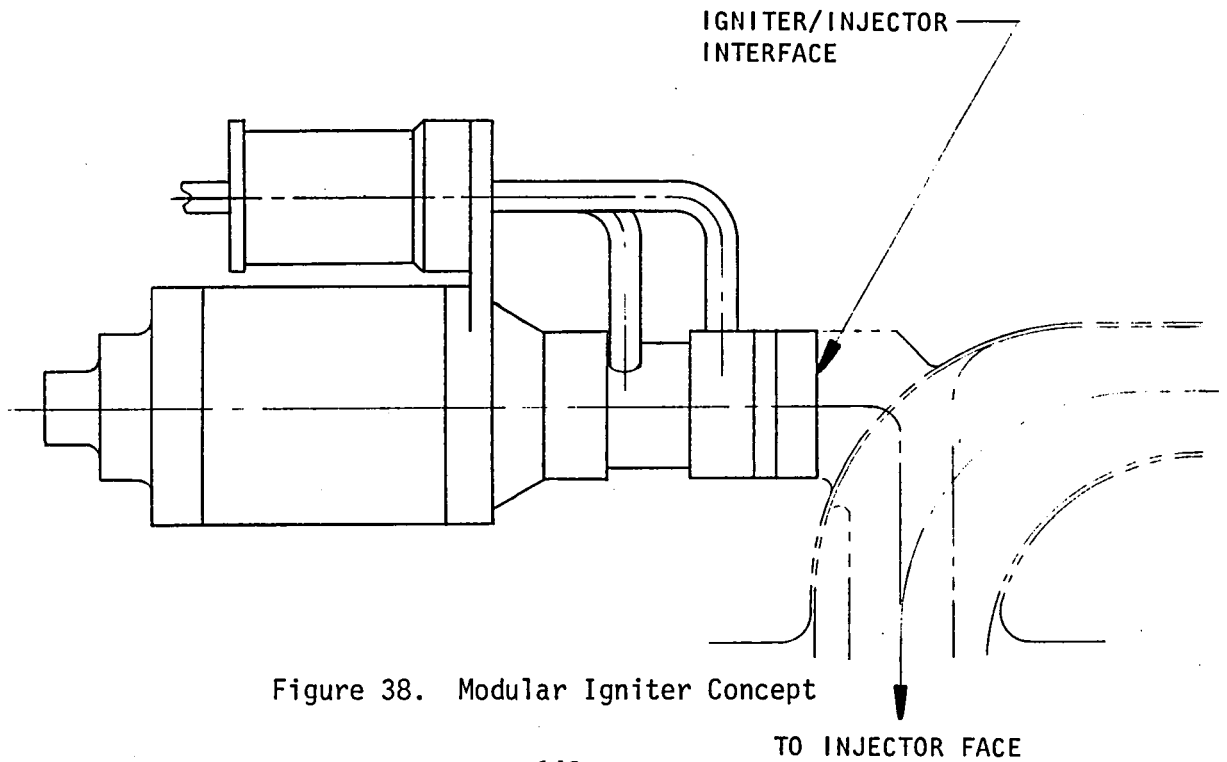
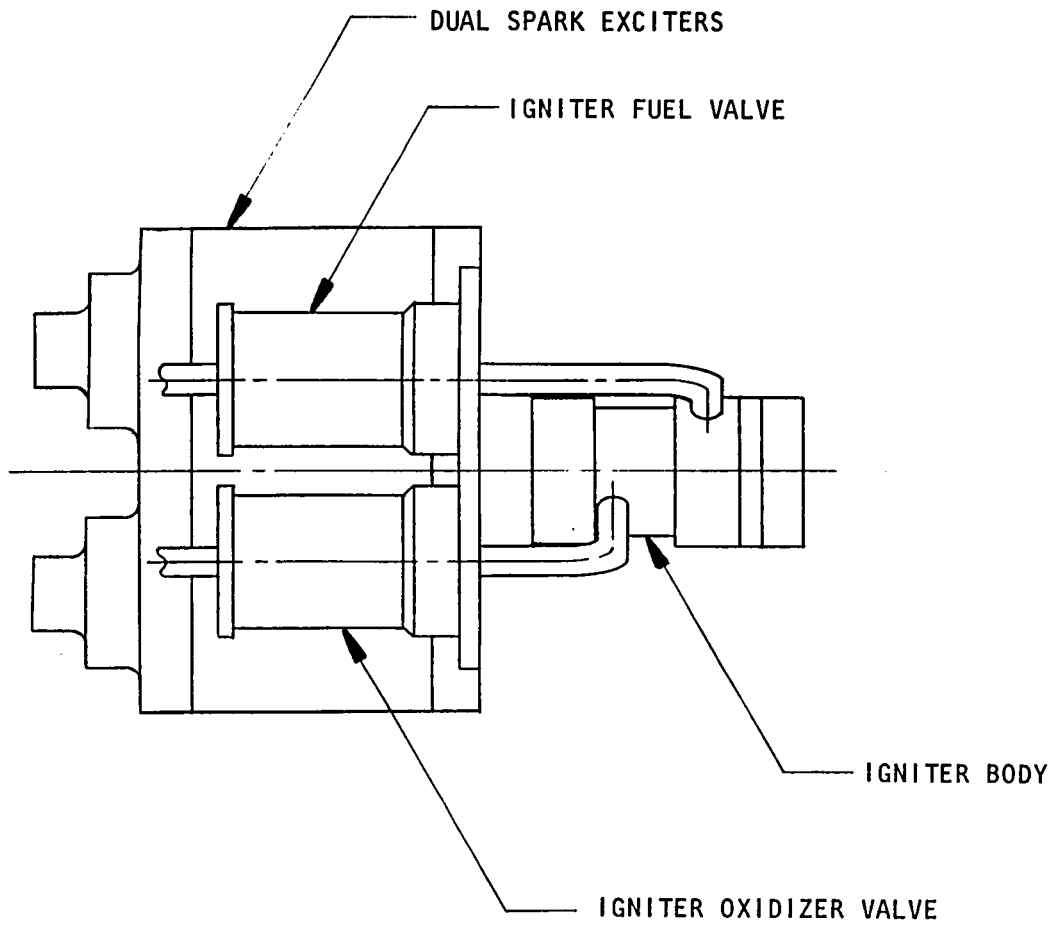

Figure 38. Modular Igniter Concept

TABLE 43.
IGNITER COMPARISON

	<u>Baseline</u>	<u>Modular</u>
<u>Fluid Joints</u>	6	3
<u>Fluid Seals</u>	7 (2 Valve Inlets 2 Valve Outlets 1 Igniter Body 2 Spark Plugs)	4 (2 Valve Inlets 2 Igniter Body)
<u>Electrical Joints</u>	5 (2 Exciters 2 Valves 1 Instrumentation)	2 (2 Exciters; Valves & Instrumentation Integrated into Exciter Couplings)
<u>Weight</u>	Negligible Difference	
<u>Cost</u>	Baseline	Initial cost higher Unit repair cost higher Space service cost lower

TECHNOLOGY PLANS

Technology development plans were generated for several of the innovative concepts evaluated as being technologically feasible with fruition expected within the time frames of interest. These technology development summaries are presented in this section for the selected concepts using a uniform format. A two-page summary is provided for each technology task. The first page describes the recommended technology by its objectives, current development status, and benefits. The technology type (focused or generic), development timeframe, and the components affected are also identified. A brief Statement of Work is included to define the basic efforts to be performed. The second page of each summary discusses the impact of not developing the technology. Potential alternative technologies and the technical risks involved are provided. Finally, a technology advancement schedule identifies the technology subtasks with their schedule, and the test facilities required. The number at the top of each technology summary sheet is cross-referenced with the technology plan number in the concepts list.

OTV ENGINE TECHNOLOGY TASK NO. 1

1.

TECHNOLOGY TASK TITLE: Turbine Shutoff Valve (TSV)

2.

MAJOR TECHNOLOGY GROUP TITLE: Valves

3.

TECHNOLOGY TYPE: OTV FOCUSED X GENERIC

4.

PROPULSION COMPONENT(S) AFFECTED: Turbopumps, actuators, electronic controller

5.

OBJECTIVE OF TECHNOLOGY ADVANCEMENT: Incorporate a turbine drive gas shut off valve into the engine

6.

TECHNOLOGY TIME FRAME: NEAR TERM X INTERMEDIATE LONG RANGE

7.

STATE-OF-THE-ART LEVEL: Technology developed, requires design, fabrication, and testing

8.

BRIEF WORK STATEMENT: Design, fabrication, and testing of flight-weight hot hydrogen (1100⁰R) shut off valve. Testing would be conducted on integrated components evaluator (ICE) engine.

9.

BENEFITS:

- 1). Reduces pump speed decay by ~ 33% resulting in shorter periods at damaging critical speeds, increases pump life.
- 2). Eliminates need for pump brakes in tank head idle mode, simplifies turbopump designs.

OTV ENGINE TECHNOLOGY TASK NO. 1

TECHNOLOGY TASK TITLE: Turbine Shutoff Valve (TSV)

10. IMPACT IF TECHNOLOGY NOT DEVELOPED: (Performance, Reliability, Cost, Potential Alternatives):

- 1). Shorter turbopump lives
- 2). Pump brakes required

11. TECHNICAL RISKS: Risks are low.

12. TECHNOLOGY ADVANCEMENT SCHEDULE AND COST:

SCHEDULE	FISCAL YEAR												
	86	87	88	89	90	91	92	93	94	95	96	97	98
SUBTASKS													
1. DESIGN													
2. FABRICATION													
3. VALIDATION TESTS													
<hr/>													
1. ENGINEERING LAB													
2. ICE AT SSFL													

OTV ENGINE TECHNOLOGY TASK NO. 2

1. TECHNOLOGY TASK TITLE: Consolidated turbine shutoff (TSV) and turbine bypass valve (TBV).
2. MAJOR TECHNOLOGY GROUP TITLE: Valves
3. TECHNOLOGY TYPE: OTV FOCUSED X GENERIC
4. PROPULSION COMPONENT(S) AFFECTED: Turbopumps, main fuel throttling valve, actuators, electronic controller
5. OBJECTIVE OF TECHNOLOGY ADVANCEMENT: Combine the TBV and TSV into a single unit with one actuator.
6. TECHNOLOGY TIME FRAME: NEAR TERM INTERMEDIATE X LONG RANGE
7. STATE-OF-THE-ART LEVEL: Most sub-elements have been proven, but the combination of these elements in an actuator/valve assembly is a new development. Preliminary design sketch generated.
8. BRIEF WORK STATEMENT: Design, fabrication, and testing of a prototype and flightweight consolidated main fuel throttling valve and turbine shutoff valve (electric motor actuator, low noise, low torque valve)
9. BENEFITS:
 - 1). Weight Savings
 - 2). Reliability improvement with single unit

OTV ENGINE TECHNOLOGY TASK NO. 2

TECHNOLOGY TASK TITLE: Consolidated TSV and TBV

10. IMPACT IF TECHNOLOGY NOT DEVELOPED (Performance, Reliability, Cost, Potential Alternatives): Separate TBV and TSV (see technology Task No. 1) resulting in increased weight and lower overall reliability

11. TECHNICAL RISKS:

- 1). Hot H₂ leak across metal/metal seals
- 2). Precision clutch for pneumatic override

12. TECHNOLOGY ADVANCEMENT SCHEDULE AND COST:

SCHEDULE	FISCAL YEAR													
	86	87	88	89	90	91	92	93	94	95	96	97	98	
SUBTASKS														
1. PROTOTYPE UNIT														
2. FLIGHTWEIGHT														
<hr/>														
1. ENGINEERING LAB														
2. ICE AT SSFL														

OTV ENGINE TECHNOLOGY TASK NO. 3

1. TECHNOLOGY TASK TITLE: Consolidated main oxidizer valve (MOV) and gaseous oxidizer valve (GOV)
2. MAJOR TECHNOLOGY GROUP TITLE: Valves
3. TECHNOLOGY TYPE: OTV FOCUSED X GENERIC ___
4. PROPULSION COMPONENT(S) AFFECTED: MOV (throttling), actuators, electronic controller
5. OBJECTIVE OF TECHNOLOGY ADVANCEMENT: Combine MOV and GOV into a single unit with one actuator
6. TECHNOLOGY TIME FRAME: NEAR TERM ___ INTERMEDIATE X LONG RANGE ___
7. STATE-OF-THE-ART LEVEL: Same as for consolidated TSV/TBC (Tech. Task No. 2)
8. BRIEF WORK STATEMENT: Same as for consolidated TSV/TBV (Tech. Task No. 2)
9. BENEFITS:
 - 1). Weight savings
 - 2). Reliability improvement with single unit

OTV ENGINE TECHNOLOGY TASK NO. 3

TECHNOLOGY TASK TITLE: Consolidated MOV and GOV

10. IMPACT IF TECHNOLOGY NOT DEVELOPED: (Performance, Reliability, Cost, Potential Alternatives): Separate MOV and GOV would be required resulting in increased weight and lower overall reliability

11. TECHNICAL RISKS:

1). Precision clutch for pneumatic override

12. TECHNOLOGY ADVANCEMENT SCHEDULE AND COST:

SCHEDULE	FISCAL YEAR												
	86	87	88	89	90	91	92	93	94	95	96	97	98
SUBTASKS													
1. PROTOTYPE UNIT		█	█	█									
2. FLIGHTWEIGHT			█	█	█	█	█	█					
1. ENGINEERING LAB			█				█	█					
2. ICE AT SSFL				█				█					

OTV ENGINE TECHNOLOGY TASK NO. 4

1. TECHNOLOGY TASK TITLE: Electric Actuated Cartridge Valves
2. MAJOR TECHNOLOGY GROUP TITLE: Valves, Space Maintenance
3. TECHNOLOGY TYPE: OTV FOCUSED GENERIC
4. PROPULSION COMPONENT(S) AFFECTED: Valves, Ducting, and Flanges
5. OBJECTIVE OF TECHNOLOGY ADVANCEMENT: Develop cartridge coupling and seat seal replacement capability to enhance space-based servicing.
6. TECHNOLOGY TIME FRAME: NEAR TERM INTERMEDIATE LONG RANGE
7. STATE-OF-THE-ART LEVEL: Prototype of cartridge valve fabricated.
8. BRIEF WORK STATEMENT:
 1. Identify coupling and seal replacement methods.
 2. Perform operational analysis.
 3. Fabricate servicing tools.
 4. Perform operational space servicing tests.
9. BENEFITS:

Enhanced space-based maintainability. Improved servicing reliability.
Lower servicing costs.

OTV ENGINE TECHNOLOGY TASK NO. 4

TECHNOLOGY-TASK TITLE: Electric Actuated Cartridge Valves

10. IMPACT IF TECHNOLOGY NOT DEVELOPED: Space-based repairs and replacements more difficult. Higher risk of seal damage during space installation.

11. TECHNICAL RISKS: Low risk - seal damage upon space servicing.

12. TECHNOLOGY ADVANCEMENT SCHEDULE AND COST:

SCHEDULE	FISCAL YEAR												
	86	87	88	89	90	91	92	93	94	95	96	97	98
SUBTASKS													
1. IDENTIFY COUPLING REPLACEMENT METHODS	<input type="checkbox"/>												
2. PERFORM OPERATIONAL ANALYSIS		<input type="checkbox"/>											
3. FABRICATE SERVICING TOOLS			<input type="checkbox"/>										
4. PERFORM OPERATIONAL SPACE SERVICING TESTS				<input type="checkbox"/>									
<hr/>													
1. ENGINEERING LAB		<input type="checkbox"/>											

OTV ENGINE TECHNOLOGY TASK NO. 5

1. TECHNOLOGY TASK TITLE: Modular Igniter
2. MAJOR TECHNOLOGY GROUP TITLE: Space Maintainability
3. TECHNOLOGY TYPE: OTV FOCUSED X GENERIC ___
4. PROPULSION COMPONENT(S) AFFECTED: Ignition system components: Igniter body, spark plugs, spark exciters, igniter valves, and igniter instrumentation as well as igniter interface of the main injector.
5. OBJECTIVE OF TECHNOLOGY ADVANCEMENT: Improve maintainability of the ignition system.
6. TECHNOLOGY TIME FRAME: NEAR TERM X INTERMEDIATE ___ LONG RANGE ___
7. STATE-OF-THE-ART LEVEL: Module elements well defined; integrated unit requires development.
8. BRIEF WORK STATEMENT: Prepare preliminary design of igniter module and compatible injector interface. Perform thermal and structural analysis to verify performance and life goals. Prepare preliminary design of test configuration for use with the Integrated Components Evaluator.
9. BENEFITS: Reduced number of fluid joints and seals. Reduced number of electrical interconnects. Enhanced space replacement capability. Increased engine reliability. Faster engine turnaround. Reduced life-cycle costs.

OTV ENGINE TECHNOLOGY TASK NO. 5

TECHNOLOGY TASK TITLE: Modular Igniter

10. IMPACT IF TECHNOLOGY NOT DEVELOPED: (Performance, Reliability, Cost, Potential Alternatives): Space servicing costs associated with the ignition system higher due to longer replacement task times as requirements to remove engine for igniter maintenance. Engine reliability lower because of additional interconnects in non-modular system. Component cost lower than modular design.

11. TECHNICAL RISKS: Low

12. TECHNOLOGY ADVANCEMENT SCHEDULE AND COST:

SCHEDULE	FISCAL YEAR												
	86	87	88	89	90	91	92	93	94	95	96	97	98
SUBTASKS													
1. PRELIMINARY DESIGN	<input type="checkbox"/>												
2. DESIGN ANALYSIS	<input type="checkbox"/>												
3. TEST CONFIGURATION DESIGN	<input type="checkbox"/>												
NONE													

OTV ENGINE TECHNOLOGY TASK NO. 6

1. TECHNOLOGY TASK TITLE: Lightweight, high strength composite materials
(for non-rotating OTV engine components)
2. MAJOR TECHNOLOGY GROUP TITLE:
3. TECHNOLOGY TYPE: OTV FOCUSED GENERIC
4. PROPULSION COMPONENT(S) AFFECTED: Non-rotating OTV engine components,
i.e., housings, ductings
5. OBJECTIVE OF TECHNOLOGY ADVANCEMENT: Reduce engine weight, increase
performance
6. TECHNOLOGY TIME FRAME: NEAR TERM INTERMEDIATE LONG RANGE
7. STATE-OF-THE-ART LEVEL: Developmental
8. BRIEF WORK STATEMENT: To develop low pressure propellant ducts
including: ducting (including elbows) articulated bellow joints and
flanges, using different kinds of SiC reinforced composite materials.
9. BENEFITS: The composite propellant ducts will save 24% of the weight.
Using the superplastic forming and diffusion bonding technique will save
significant amount of fabrication cost.

OTV ENGINE TECHNOLOGY TASK NO. 6

TECHNOLOGY TASK TITLE: Lightweight, high strength composite materials
(for non-rotating OTV engine components)

10. IMPACT IF TECHNOLOGY NOT DEVELOPED: (Performance, Reliability, Cost, Potential Alternatives): A potential 24% total engine weight saving cannot be realized.

11. TECHNICAL RISKS: Medium: (1) The DB processing of SiC/Al may not be practical for hardware fabrication (2) The bellow may not be formed superplastically

12. TECHNOLOGY ADVANCEMENT SCHEDULE AND COST:

SCHEDULE	FISCAL YEAR												
	86	87	88	89	90	91	92	93	94	95	96	97	98
SUBTASKS													
1. SPF/DB OF SiC/Al COMPOSITE		■	■										
2. SUBCOMPONENT FABRICATION			■	■									
3. DUCTING ASSEMBLY				■	■								
4. TESTING					■	■							
1. SSFL					■	■							

OTV ENGINE TECHNOLOGY TASK NO. 7

1. TECHNOLOGY TASK TITLE: High expansion ratio nozzle mechanical retraction/extension devices
2. MAJOR TECHNOLOGY GROUP TITLE: Nozzle
3. TECHNOLOGY TYPE: OTV FOCUSED GENERIC
4. PROPULSION COMPONENT(S) AFFECTED: Extendable Nozzle
5. OBJECTIVE OF TECHNOLOGY ADVANCEMENT: Develop mechanical retraction/extension devices for nozzle
6. TECHNOLOGY TIME FRAME: NEAR TERM INTERMEDIATE LONG RANGE
7. STATE-OF-THE-ART LEVEL: Four preliminary designs currently exist. Demonstration tests of deployment on solid rocket boosters.
8. BRIEF WORK STATEMENT:
 - 1). Design studies
 - 2). Fabrication studies
 - 3). Structural verification tests
9. BENEFITS: Performance increase from higher expansion nozzle. Smaller stored engine envelope for shuttle bay transport.

OTV ENGINE TECHNOLOGY TASK NO. 7

TECHNOLOGY TASK TITLE: High expansion ratio nozzle mechanical retraction/extension devices

10. IMPACT IF TECHNOLOGY NOT DEVELOPED: (Performance, Reliability, Cost, Potential Alternatives): Fixed nozzle (limited performance). Longer engine package while stored in shuttle bay, or need to utilize complex geometric means to provide high expansion ratio in a short length.

11. TECHNICAL RISKS: Mechanical complexity, reliability, weight, and structural integrity

12. TECHNOLOGY ADVANCEMENT SCHEDULE AND COST:

SCHEDULE	FISCAL YEAR												
	86	87	88	89	90	91	92	93	94	95	96	97	98
SUBTASKS													
1. DESIGN		■											
2. FABRICATION			■	■	■								
3. STRUCTURAL VERIFICATION TESTS					■								
<hr/>													
1. ENGINEERING LAB					■								
2. ICE AT SSFL						■							

OTV ENGINE TECHNOLOGY TASK NO. 8

1. TECHNOLOGY TASK TITLE: Extendable nozzle high pressure coolant fluid interconnects
2. MAJOR TECHNOLOGY GROUP TITLE: Nozzle
3. TECHNOLOGY TYPE: OTV FOCUSED GENERIC
4. PROPULSION COMPONENT(S) AFFECTED: Extendable nozzle
5. OBJECTIVE OF TECHNOLOGY ADVANCEMENT: Develop high pressure remote coolant seals capable of hermetic operation over numerous cycles
6. TECHNOLOGY TIME FRAME: NEAR TERM INTERMEDIATE LONG RANGE
7. STATE-OF-THE-ART LEVEL: Limited experience with supply of coolant to movable sections
8. BRIEF WORK STATEMENT:
 - 1). Design studies
 - 2). Fabrication studies
 - 3). Structural verification tests
9. BENEFITS: Performance increase from higher expansion nozzle. Performance increase from added nozzle heat load for turbine drive.

OTV ENGINE TECHNOLOGY TASK NO. 8

TECHNOLOGY TASK TITLE: Extendable nozzle high pressure coolant fluid interconnects

10. IMPACT IF TECHNOLOGY NOT DEVELOPED: (Performance, Reliability, Cost, Potential Alternatives): Fixed nozzle (limited performance). Longer engine package while stored in shuttle bay, or need to utilize complex geometric means to provide high expansion ratio in a short length.

11. TECHNICAL RISKS: Reliability of seal integrity. Leakage could cause disabling engine performance degradation

12. TECHNOLOGY ADVANCEMENT SCHEDULE AND COST:

SCHEDULE	FISCAL YEAR												
	86	87	88	89	90	91	92	93	94	95	96	97	98
SUBTASKS													
1. DESIGN		■											
2. FABRICATION			■	■	■								
3. VERIFICATION TESTING					■	■							
1. ENGINEERING LAB					■	■							
2. ICE AT SSFL						■	■						

OTV ENGINE TECHNOLOGY TASK NO. 9

1. TECHNOLOGY TASK TITLE: Nozzle segmentation and interface seals
2. MAJOR TECHNOLOGY GROUP TITLE: Nozzle
3. TECHNOLOGY TYPE: OTV FOCUSED GENERIC
4. PROPULSION COMPONENT(S) AFFECTED: Extendable Nozzle
5. OBJECTIVE OF TECHNOLOGY ADVANCEMENT: Develop nozzle segment interface technology to provide smooth, leak-free and reliable seals between H₂ cooled and radiation cooled segments
6. TECHNOLOGY TIME FRAME: NEAR TERM INTERMEDIATE LONG RANGE
7. STATE-OF-THE-ART LEVEL: Some related experience on solid rocket boosters
8. BRIEF WORK STATEMENT: Design, fabrication, and testing of segment interface seals integrated with overall retractable nozzle development.
9. BENEFITS: Performance increase from higher expansion nozzle. Smooth interface seals minimize added nozzle boundary layer drag losses.

OTV ENGINE TECHNOLOGY TASK NO. 9

TECHNOLOGY TASK TITLE: Nozzle segmentation and interface seals

10. IMPACT IF TECHNOLOGY NOT DEVELOPED: (Performance, Reliability, Cost, Potential Alternatives): Fixed nozzle (limited performance) longer engine package

11. TECHNICAL RISKS: Reliability of seal integrity. Leakage could cause nozzle damage and performance degradation

12. TECHNOLOGY ADVANCEMENT SCHEDULE AND COST:

SCHEDULE	FISCAL YEAR												
	86	87	88	89	90	91	92	93	94	95	96	97	98
SUBTASKS													
1. DESIGN													
2. FABRICATION													
3. VERIFICATION TESTING													
1. ENGINEERING LAB													
2. ICE AT SSFL													

OTV ENGINE TECHNOLOGY TASK NO. 10

1. TECHNOLOGY TASK TITLE: Space Operable Fluid Disconnects
2. MAJOR TECHNOLOGY GROUP TITLE: Space Maintainability
3. TECHNOLOGY TYPE: OTV FOCUSED GENERIC
4. PROPULSION COMPONENT(S) AFFECTED: Engine/Vehicle interface joints and all fluid components requiring space replacement capability
5. OBJECTIVE OF TECHNOLOGY ADVANCEMENT: Provide a demonstrated space operable disconnect technology with which engine space maintenance plans can be confidently made
6. TECHNOLOGY TIME FRAME: NEAR TERM INTERMEDIATE LONG RANGE
7. STATE-OF-THE-ART LEVEL: Many devices have been identified at conceptual level. No current devices exist which meet the needs of cryogenic space engine systems.
8. BRIEF WORK STATEMENT: Prepare conceptual designs of disconnect devices. Assess concepts and rank for OTV applicability. Perform structural, thermal operational, or other analysis as needed to evaluate the better candidates. Prepare preliminary flight design of selected concepts. Establish verification test goals and plan. Prepare detail design of breadboard version of concept. Fabricate test unit. Conduct operational and performance testing.
9. BENEFITS: Reduced life cycle costs. Faster engine turnaround

OTV ENGINE TECHNOLOGY TASK NO. 10

TECHNOLOGY TASK TITLE: Space Operable Fluid Disconnects

10. IMPACT IF TECHNOLOGY NOT DEVELOPED (Performance, Reliability, Cost, Potential Alternatives): Space servicing costs higher due to longer task times required to replace engine or components.

11. TECHNICAL RISKS: Medium

12. TECHNOLOGY ADVANCEMENT SCHEDULE AND COST:

SCHEDULE	FISCAL YEAR												
	86	87	88	89	90	91	92	93	94	95	96	97	98
SUBTASKS													
1. CONCEPTUAL DESIGN	□												
2. ASSESS CONCEPTS	□												
3. ANALYSIS	□												
4. PRELIMINARY DESIGN	□												
5. TEST PLAN	□												
6. DETAIL DESIGN		□											
7. FABRICATION			□										
8. TEST				□									
ENGINEERING LAB				□									



TABLE 1-1. VEHICLE DERIVED REQUIREMENTS FOR ICHM SYSTEM

PAGE 1-1

SOURCE ->	MARTIN MARIETTA	GENERAL DYNAMICS	BOEING AEROSPACE	G.E. GRUMMAN	ROCKETDYNE ASSUMPTIONS	*
I. GENERAL INFORMATION						
-LAST REVIEW BRIEFING	PHASE I REVIEW BRIEFING (JUNE 84)	MIDTERM REVIEW BRIEFING (6/26/84)	PHASE II FIRST REVIEW (JULY 84)	PHASE II FIRST REVIEW (7/17/84)		
-RECEIVE MONTHLY REPORTS?	Y, (6TH)	Y, (3RD)	N	N		
-STUDY FOCUS	PROPULSION	PROPULSION	AERDASSIST (LOW L/D)	AERDASSIST (MID L/D)		
-SPONSORING AGENCY	NASA-LERC	NASA-LERC	NASA-MSFC	NASA-MSFC		
-PRIME CONTRACTOR	PWA	ALRC	--	--		
-SUBCONTRACTOR	EAGLE ENGRG	--	GOODYEAR	GRUMMAN		
-CONTRACT NUMBER	127985	L-814740	NAS 8-35095	NAS 8-35096		
-OTHER RELATED CONTRACTS	OTV CONCEPT DEFINITION & SYST. ANALYSIS (NASA-MSFC)		OTV CONCEPT DEFINITION & SYST. ANALYSIS (NASA-MSFC)			

* ITEMS RELEVANT TO THE ICHM SYSTEM

APPENDIX 1
VEHICLE DERIVED
REQUIREMENTS FOR ICHM SYSTEM

Table 1-1 (Cont'd)

VEHICLE DERIVED REQUIREMENTS FOR ICHM SYSTEM

SOURCE ->	MARTIN MARIETTA	GENERAL DYNAMICS	BOEING AEROSPACE	G.E. GRUMMAN	ROCKETDYNE ASSUMPTIONS	*
II. MISSION REQUIREMENTS						
-TARGET ORBITS	GEOSYNCHRONOUS	GEOSYNCHRONOUS	-GEOSYNCHR. -6HR POLAR -MOLNIYA -5 x GEO	-GEOSYNCHR. -6HR POLAR -MOLNIYA -5 x GEO	GEOSYNCHRONOUS (PRIMARY)	
-BASELINE MISSION(S) (MOSTLY MSFC MOD. REV.6)	1)DEL. 16 KLB, RETURN EMPTY, AERDASSISTED, UNMANNED	1)DEL. 10 TO 16 KLB, (GEO PLATFORM AND LSSCDS)	1)DEL. 20 KLB, RETURN EMPTY, AERDASSISTED, UNMANNED	1)DELIVERY UP TO 55KLB	1)DELIVER UP TO 16 KLB TO GEO AND RETURN	X
	2)DEL. 13 KLB, ROUNDTRIP, AERDASSISTED, MANNED	2)DEL. 13 KLB, ROUNDTRIP, AERDASSISTED, MANNED	2)DEL. 14 KLB, ROUNDTRIP, AERDASSISTED, MANNED	2)MANNED ROUND TRIP, CREW OF 5-6	2)MANNED ROUND TRIP TO GEO WITH 13 KLB PAYLOAD	
		3)GEO SATELL. NASA,DOD,ETC, +UNMANNED SERVICING	3)DEL. 6 KLB, RETURN 2 KLB, AERDASSISTED, UNMANNED	3)SERVICING	3)UNMANNED SAT SERVICING- DELIVER 6K, RETURN 3K	
		4)MANIFESTED COMMERCIAL SATELLITES			1B)LOW THRUST DELIVERY MISSIONS	
-MPS DELTA-V: LEO-GEO GEO-LEO	13985 FPS 6600 FPS A/B RETURN	^14000 FPS ^6600 FPS A/B RETURN		^14000 FPS ^7000 FPS A/B RETURN	^14000 FPS ^7000 FPS A/B RETURN	
-DELTA-V LOSSES	^325 FPS	^100 FPS			FUNCTION(F/W, #BURNS,ETC)	
-NUMBER OF PERIGEE BURNS	SINGLE BURN NOMINAL	POSSIBLY MULTI-BURNS	BASELINE 2 PERIGEE BURN		SMALL NR OF BURNS POSSIBLE	X

* ITEMS RELEVANT TO THE ICHM SYSTEM

RI/RD86-116

1-2



Table 1-1 (cont'd)

PAGE II-2

VEHICLE DERIVED REQUIREMENTS FOR ICHM SYSTEM

21-Aug-84

SOURCE ->	MARTIN MARIETTA	GENERAL DYNAMICS	BOEING AEROSPACE	G.E. GRUMMAN	ROCKETDYNE ASSUMPTIONS	*
-AERDASSIST MANEUVER	UP TO 3 PASS 1 NOMINAL	1 OR 2 PASS 2 NOMINAL	SINGLE PASS	SINGLE PASS	SINGLE PASS NOMINAL	X
-AERDASSIST DELTA-V	7800 FPS	^7000 FPS	^7500 FPS	^7000 FPS	^7000 FPS	
-SPACE STATION ORBIT: ALTITUDE INCLINATION	250 N.M.	220 N.M. 28.5 DEG	220 N.M. 28.5 DEG	220 N.M. 28.5 DEG	220 N.M. 28.5 DEG	

* ITEMS RELEVANT TO THE ICHM SYSTEM

RI/RD86-116

1-3

Table 1-1 (cont'd)

PAGE III-1

VEHICLE DERIVED REQUIREMENTS FOR ICHM SYSTEM

21-Aug-84

SOURCE ->	MARTIN MARIETTA	GENERAL DYNAMICS	BOEING AEROSPACE	G.E. GRUMMAN	ROCKETDYNE ASSUMPTIONS	*	
III. OTV OPERATIONS							
-DELIVERY TO SPACE STATION	DISASSEMBLED & EMPTY, IN STS PL BAY	DISASSEMBLED & EMPTY, IN STS PL BAY			DISASSEMBLED IN STS CARGO BAY	DISASSEMBLED & EMPTY, IN STS PL BAY	X
-LAUNCH & RECOVERY FROM SS	RMS, GRAPPLE			OMV, RMS		RMS	X
-MANEUVERS AROUND STATION	UNDEFINED ACS,MMU,OMV			MPS INACTIVE W/IN 3 MILES OF STATION		RMS,ACS,OMV	X
-TYPICAL MISSION TIMELINES	SEE ATTACHED	SEE ATTACHED				SEE ATTACHED	X
-TYPICAL MAINTENANCE OPS	SEE ATTACHED	SEE ATTACHED				SEE ATTACHED	X
-CONTINGENCY RETURN	TANK HEAD IDLE OR ACS					THIM OR ACS, MAYBE RESCUE VEHICLE	X

* ITEMS RELEVANT TO THE ICHM SYSTEM

RI/RD86-116

1-4

Table 1-1 (cont'd)

PAGE IV-1

VEHICLE DERIVED REQUIREMENTS FOR ICHM SYSTEM

22-Aug-84

SOURCE ->	MARTIN MARIETTA	GENERAL DYNAMICS	BOEING AEROSPACE	G.E. GRUMMAN	ROCKETDYNE ASSUMPTIONS	#
IV. VEHICLE DESCRIPTION						
-BASELINE VEHICLE	MODULAR, REUSABLE	MODULAR, REUSABLE	CONVENTIONAL, REUSABLE	REUSABLE CORE, W/ DROP TANKS, MAY BE STAGED	MODULAR, REUSABLE, POSSIBLY STAGED OR WITH DROP TANKS	X
-MASS FRACTION	0.864	0.893		~0.9	~0.86-0.90	
-NOMINAL PROPELLANT LOAD	42 KLB	53 KLB, 4 TANKS 26 KLB, 2 TANKS	55 KLB	UP TO 130 KLB	VARIABLE	
-H2 TANKS	2, SPHERICAL	2/4, SPHER.	1, SPHER./CYL.	1, ELLIPSOIDAL	SPHERICAL	
-O2 TANKS	2, SPHERICAL	2/4, SPHER.	1, SPHERICAL	1, ELLIPSOIDAL	SPHERICAL	
-BASING MODE	SPACE STATION	SPACE STATION	STS/SPACE	STS/SPACE	SPACE STATION	X
-BASELINE AERDASSIST DEVICE	LIFTING BRAKE	LIFTING BRAKE BUT CONSIDER BALLUTE AND BI-CONIC	LIKELY TO FAVOR BALLUTE BUT LOOKING AT LIFTING BRAKE & SLED	BICONIC WITH BODY FLAP	PROBABLY LIFTING BRAKE	X
-LIFT-TO-DRAG RANGE			0<L/D<0.75	0.75<L/D<1.5	LOW L/D	
-ENGINE DIRECTION WHEN AEROBRAKING	FORWARD	FORWARD	AFT, SOME FORWARD	AFT	FORWARD	
-ENGINE PROTECTION DURING		-FAVOR COOLED	-HEAT SHIELDS	-BODY FLAP	DOORS OR	X

* ITEMS RELEVANT TO THE ICHM SYSTEM

RI/RD86-116

1-5

Table 1-1 (cont'd)

PAGE IV-2

VEHICLE DERIVED REQUIREMENTS FOR ICHM SYSTEM

22-Aug-84

SOURCE ->	MARTIN MARIETTA	GENERAL DYNAMICS	BOEING AEROSPACE	G.E. GRUMMAN	ROCKETDYNE ASSUMPTIONS	*
AEROPASS		DOORS -BLEED COOLING -RUN ENGINE -RADIATION	-JETT. NOZZLES -WATER SPRAY	-RETRACTABLE NOZZLES	RUN ENGINE	
-OTHER VEHICLE TYPES	-CONVENTIONAL TYPE	-TOROID. ACC -TOROID STS BASED -CENTAUR DERIVATIVES	-MODULAR ACC -CONVENTIONAL STS BASED	-38FT INTERNAL TANK VEHICLE -H-1,H-1M, OH-2M,OH-3SB	-ACC OTV -BICONIC OTV -VARIOUS STAGING CONCEPTS	
-STORAGE AND SHELTER	SPACE STATION SERVICE BERTH	SS SHELTER POSSIBLY PARTIALLY PRESSURIZED	SPACE HANGAR		SPACE HANGAR -BOTH EVA OR IVA TO BE CONSIDERED	X
-BASELINE AVIONICS			HI-SPEED SERIAL DATA BUS		ADEQUATE REDUNDANCY, ADV. ELECTR.	X
-ELECTRICAL POWER SYSTEM	-MAIN: FUEL CELLS -BACKUP: SMALL BATTERIES		TRIPLE REDUND. FUEL CELL 2 KW NUM. 3.5 KW PEAK		FUEL CELL, BATTERY BACKUP	X
-MANRATING	FO/FS	MUTIPLE ENGINES OR SINGLE WITH BACKUP	>0.998,F/S	FS/FS	FO/FS?	X
-SAFETY REQUIREMENTS	NHB 1700.7A NEAR S/S,STS				NHB 1700.7A NEAR SS,STS	X

* ITEMS RELEVANT TO THE ICHM SYSTEM

RI/RD86-116

1-6



Rockwell International
Rocketdyne Division

Table 1-1 (cont'd)

PAGE IV-3

VEHICLE DERIVED REQUIREMENTS FOR ICHM SYSTEM

22-Aug-84

SOURCE ->	MARTIN MARIETTA	GENERAL DYNAMICS	BOEING AEROSPACE	G. E. GRUMMAN	ROCKETDYNE ASSUMPTIONS	*
-OTV DESIGN LIFE	30 MISSIONS WITH 2 OTVS				30 MISSIONS WITH 2 OTVS	X
-FEED SYSTEM SCHEMATIC	SEE ATT.		SEE ATT.		SEE ATTACHED	X
-ACS	-GH2/G02 -POSITIONING, ALIGNMENT, MIDCOURSE CORRECTIONS -SAFE MANEUVER NEAR SS -BACKUP MPS		-IUS HARDWARE -MONOPROP. HYDRAZINE -N2 PRESS. -25 LB THRUST	-NTO/MMH -F ¹⁰⁰ LBF -ISP ³⁰⁰ SEC	-FAVOR H2/O2 -BACKUP MPS -MANEUVERS NEAR SS, AND TRAJECTORY CORRECTIONS	X
-FILL/DRAIN/DUMP	COMPATIBLE WITH S/S		250 SEC ABORT DUMP		COMPATIBILITY WITH SS,STS	X
-VENTING	NOT NEAR S/S ACTIVE TVS				COMPATIBILITY WITH SS,STS	X
-PU SYSTEM	-FLIGHT: POINT SENSORS -SS: O-G GAGE OR FLOWMETER				POINT SENSORS, MAYBE SCREENS	
-THERMAL CONTROL	1/2 IN. MLI					

* ITEMS RELEVANT TO THE ICHM SYSTEM

RI/RD86-116

1-7

Table 1-1 (cont'd)

PAGE V-1

VEHICLE DERIVED REQUIREMENTS FOR ICHM SYSTEM

22-Aug-84

SOURCE ->	MARTIN MARIETTA	GENERAL DYNAMICS	BOEING AEROSPACE	G.E. GRUMMAN	ROCKETDYNE ASSUMPTIONS	*
V. MAIN PROPULSION SYSTEM:						
-PROPELLANTS	LH2/L02	LH2/L02	LH2/L02	LH2/L02	LH2/L02	X
-AREA RATIO			1500:1	1000:1	^1000:1	X
-NR OF ENGINES	2 TO 4, OR 1 WITH ACS BACKUP	1 TO 4, PREFER 2 WITH BACKUP	2+	1 TO 6	2, OR 1 WITH ACS BACKUP	X
-TOTAL TRHUST	15 KLB	HI:8 TO 12 KLB LO:500-1500 LB	15 KLB	15 KLB	15 KLB	X
-THRUST PER ENGINE		1500 LB-15 KLB OPT 3K-6K	5 TO 7 KLB	3 KLB BASELINE &500 LB LSSCDS AS BACKUP	7.5 TO 15 KLB	X
-PERFORMANCE	>460 SEC			>480 SEC	>480 SEC	
-INITIAL THRUST/WEIGHT	0.22 G				0.22 G	X
-MAX ACCELERATION LOAD	3.2 G (STS)				3.2 G	X
-NR OF BURNS PER MISSION	6 BURNS NOMINAL				6 BURNS NOMINAL	X
-BURN TIME	21 MIN. NOM.				21 MIN. NOM.	X
-ENGINE FIRING DURING A/B? (COOLING, DRAG MODULATION)	PROBABLY	PROBABLY NOT (DOORS)	POSSIBLY (BALLUTE?)	PROBABLY NOT	POSSIBLY	X
-THROTTLING	Y	Y	PROBABLY	PROBABLY	Y	X

* ITEMS RELEVANT TO THE ICHM SYSTEM

1-8
RI/RD86-116
 Rockwell International
 Rocketdyne Division

Table 1-1 (cont'd)

PAGE V-2

VEHICLE DERIVED REQUIREMENTS FOR ICHM SYSTEM

22-Aug-84

SOURCE ->	MARTIN MARIETTA	GENERAL DYNAMICS	BOEING AEROSPACE	G.E. GRUMMAN	ROCKETDYNE ASSUMPTIONS	*
-THROTTLING RANGE	100 TO 800 LB CONTINUOUS OR STEPWISE			CONTINUOUS	30:1 GOAL (THI, PHI, MSTB)	X
-DIFFERENTIAL THROTTLING?	MAYBE	MAYBE	MAYBE	MAYBE	PROBABLY NOT	X
-GIMBAL ENGINES?	PROBABLY 2 AXES, 19 DEG	PROBABLY	PROBABLY	5 TO 22 DEG HINGED (4 DEG)	6 DEGREE SQUARE PATTERN	X
-GIMBAL ACTUATORS			ELECTRIC			
-MIXTURE RATIO	6.0 NOMINAL				6.0 NOMINAL	X
-MR RANGE	5.0 TO 7.0	4 TO 7?		UP TO 7.0	5.0 TO 7.0	X
-RELIABILITY	>0.9925/BURN		0.99573 MPS		1.0 GOAL	X
-REDUNDANCY	FO/FS		AT LEAST FS	FS/FS	FO/FS	X
-MAX TIME ON ORBIT	2 WEEKS NOM.		NOM: 107.5 HRS LONG: 533.9 HRS		2 WEEKS NOM.	X
-ENG LIFE BETWEEN OVERHAUL	10 HRS				500 ST/20 HRS	X
-ENG LIFE BETWEEN SERVICE					100 ST/ 4 HRS	X
-PRESSURIZATION	AUTOGENOUS 0.18 LBM/S @2000 PSIA @540R		AUTOGENOUS		AUTOGENOUS	X
-PNEUMATIC SUPPLY	GH2/GO2 ACCUMULATOR				ACCUMULATOR IN VEHICLE?	X

* ITEMS RELEVANT TO THE ICHM SYSTEM



Table 1-1 (cont'd)

VEHICLE DERIVED REQUIREMENTS FOR ICHM SYSTEM

SOURCE ->	MARTIN MARIETTA	GENERAL DYNAMICS	BOEING AEROSPACE	G. E. GRUMMAN	ROCKETDYNE ASSUMPTIONS	*
	WILL SUPPLY ACS, EPS, PNEUMATICS, CONTINGENCY APU				WOULD LIKE TO REPLACE HELIUM WITH H2	
-ENGINE LENGTH (RETRACTED)	60 INCHES				40 INCH GOAL	X
-NOZZLE DESIGN	UP TO 2 SEGM. FOR 2 ENGINES	PROBABLY RETRACTABLE	POSS. JETTISON NOZ. EXTENSION	RETRACTABLE, TEMP > 2000 F	PROBABLY RETRACTABLE	X
-SPACE BETWEEN NOZZLES	1/2 FT				> 1/2 FT	X
-FAILURE INTERACTION	6%	NEED MINIMIZE			5% ?	X
-FUEL INLET CONDITIONS	^3 PSIA V.P.	^1-2 PSIA			0 FT NPSH	X
-OXIDIZER INLET CONDITIONS		^1-6 PSIA			0 FT NPSH	X
-ENGINE WEIGHT					360 LB GOAL	X
-IOC	1994-1997		AROUND 1990		1990-2000	X
-SYSTEM SHUTDOWN	SAFELY W/IN 10-20 MI OF SPACE STATION				SAFELY W/IN 10-20 MI OF SPACE STATION	X
-VALVE ACTUATION			ELECTRICAL		ELECTRICAL	X
-IN-FLIGHT HEALTH MONITORING CAPABILITY	Y	Y	Y	Y	Y	X
-SPACE INSPECTABILITY	Y	Y	Y	Y	Y	X

* ITEMS RELEVANT TO THE ICHM SYSTEM

RI/RD86-116
1-10



Table 1-1 (cont'd)

PAGE V-4

VEHICLE DERIVED REQUIREMENTS FOR ICHM SYSTEM

22-Aug-84

SOURCE ->	MARTIN MARIETTA	GENERAL DYNAMICS	BOEING AEROSPACE	G.E. GRUMMAN	ROCKETDYNE ASSUMPTIONS	*
-SPACE MAINTAINABILITY	Y	Y	Y	Y	Y	X
-THRUST MODULATION CONTROL (STARTUP AND SHUTDOWN RAMPS, THROTTLING)	Y	Y	Y	Y	Y	X
-MIXTURE RATIO CONTROL	Y	Y	Y	Y	Y	X
-MULTIPLE RESTARTS	Y	Y	Y	Y	Y	X

* ITEMS RELEVANT TO THE ICHM SYSTEM

RI/RD86-116

1-11

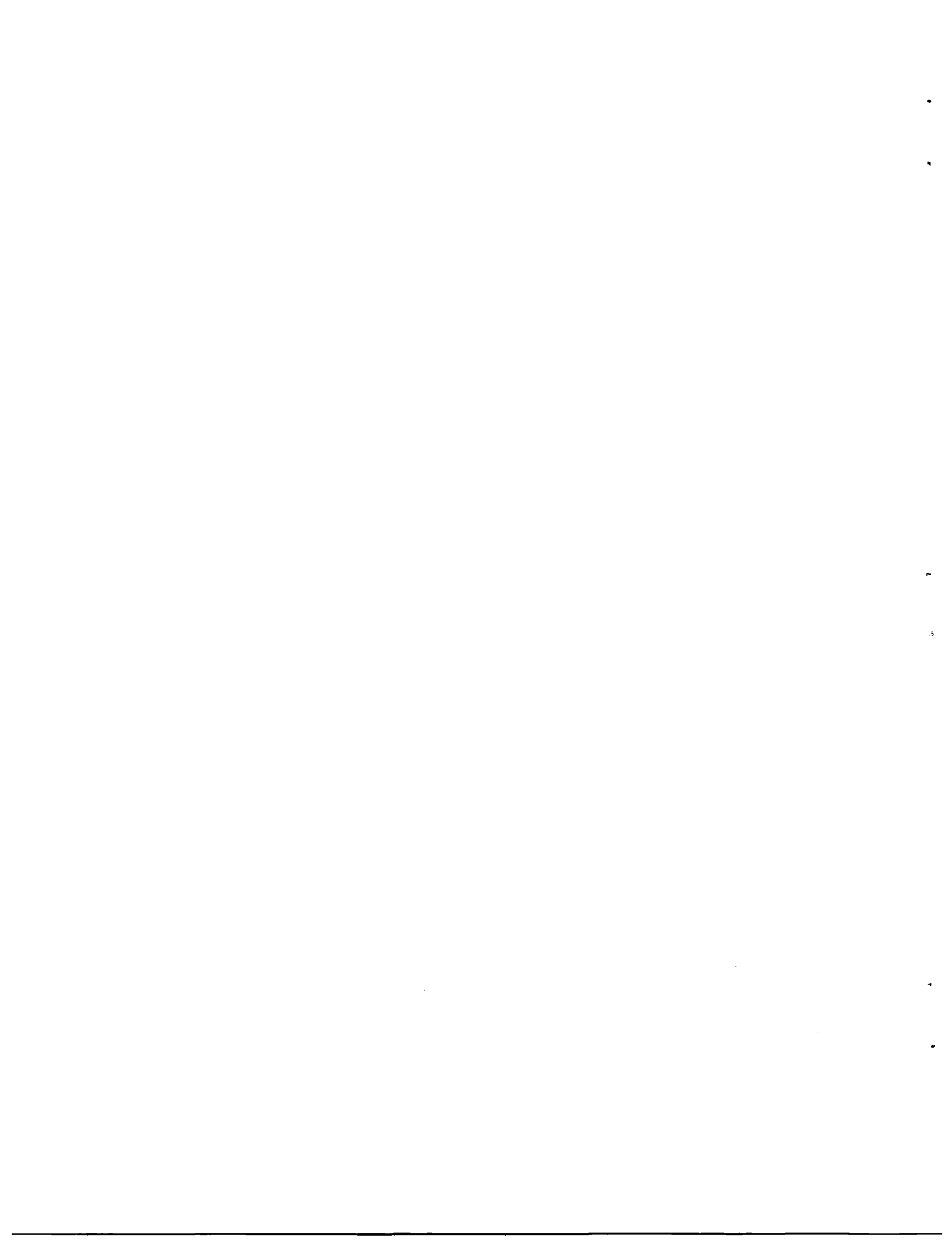

APPENDIX 2

COMBUSTOR AND NOZZLE POINT-DESIGN CONFIGURATION

The combustor and nozzle coolant jacket design obtained from parametric engine studies of the 7.5K engine were updated through a point-design study. As a first step, the combustor and nozzle contours to be used were generated. Figure 9 presents both contours. The combustor chamber is 20 inches in length. It has a 15 inch straight cylindrical section with a converging length of 5 inches to the throat. The wall radius of the converging section is chosen to avoid sharp flow turning angles (20-degree or more) which might cause flow separation. The ribs are placed on the hot-gas surface of the straight combustor section in order to provide the heat load required for high engine performance. The nozzle contour is of parabolic type with expansion and exit angles optimized at the given envelope for optimum performance. The nozzle is 89.5 inch long with an expansion area ratio of 970:1. It is regeneratively cooled from the throat to an area ratio of 398:1, and radiation cooled in the remaining length. The radiation cooled section of the nozzle may be retracted over the fixed nozzle section for an overall system length of 60 inches.

This combustor geometry was then subjected to a boundary layer analysis to determine hot-gas heat transfer coefficient profiles and to a thermal analysis to determine coolant-channel geometry heat loads and coolant pressure drop for the required life of 1200 cycles. Results of the point-design analysis are presented in Table 15 with a summary of pertinent channel geometry. Some of the more pertinent parameters are shown plotted in Figures 10 through 12 as a function of chamber length. Heat load extracted was slightly higher than previously estimated from parametric engine optimization studies, while the pressure drop was slightly lower. The full heat transfer coefficient was assumed to be in effect from rib tip to rib trough.

CONTOUR # 7 SK

CONTR. RATIO	=	4.00	AREA RATIO	=	0.700
RAD. CURV.	=	14.0280	THROAT RAD.	=	0.00452
CONVERGENCE L	=	5.0	LANOZ	=	80.54
STRAIGHT LENGTH	=	15.0	FRACTION L	=	0.0200
Mx	=	0.24500	My	=	0.06034
P	=	-0.25007	Q	=	-10.35576
S	=	40.00717	T	=	336.03353
THETA MAX	=	45.120	THETA E	=	5.302
CONV. ANGLE	=	70.301			
RPO/RT	=	0.400			

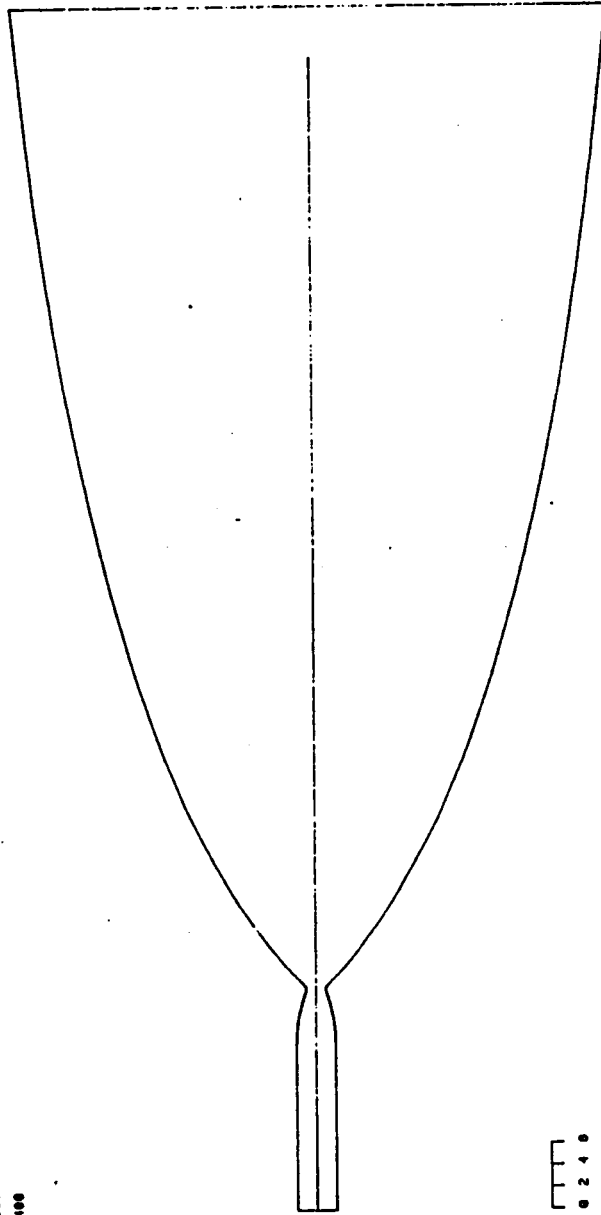

INCHES
LAL-NS
TTTTT

Figure 2-1 7.5K Engine Combustor and Nozzle Contour

TABLE 2-1 7.5K COMBUSTOR THERMAL ANALYSIS

RESULTS:

COOLANT ΔP , PSIA	1354
EXIT COOLANT BULK TEMPERATURE, R	1118
TOTAL HEAT LOAD, BTU/SEC	7907
MINIMUM WALL TEMP. °F	1043
MAXIMUM RIB TIP TEMP, °F	1591
MINIMUM LIFE, CYCLES	1200

CHANNEL RIB, AND FIN GEOMETRY

NUMBER OF CHANNELS	60/120
CHANNEL WIDTH, IN	0.040-0.060
CHANNEL HEIGHT, IN	0.055-0.240
FIN WIDTH, IN	0.02
FIN HEIGHT, IN	0.08
LAND WIDTH, IN	0.045-0.261
WALL THICKNESS, IN	0.028-0.038
RIB HEIGHT, IN	0.054
RIB WIDTH, IN	0.020-0.040

OTV COMBUSTOR, F=7.5KLB, PC=1831PSIA, LCZ=20IN, EC=4, RIBS+FINS

85/02/15
Y065790

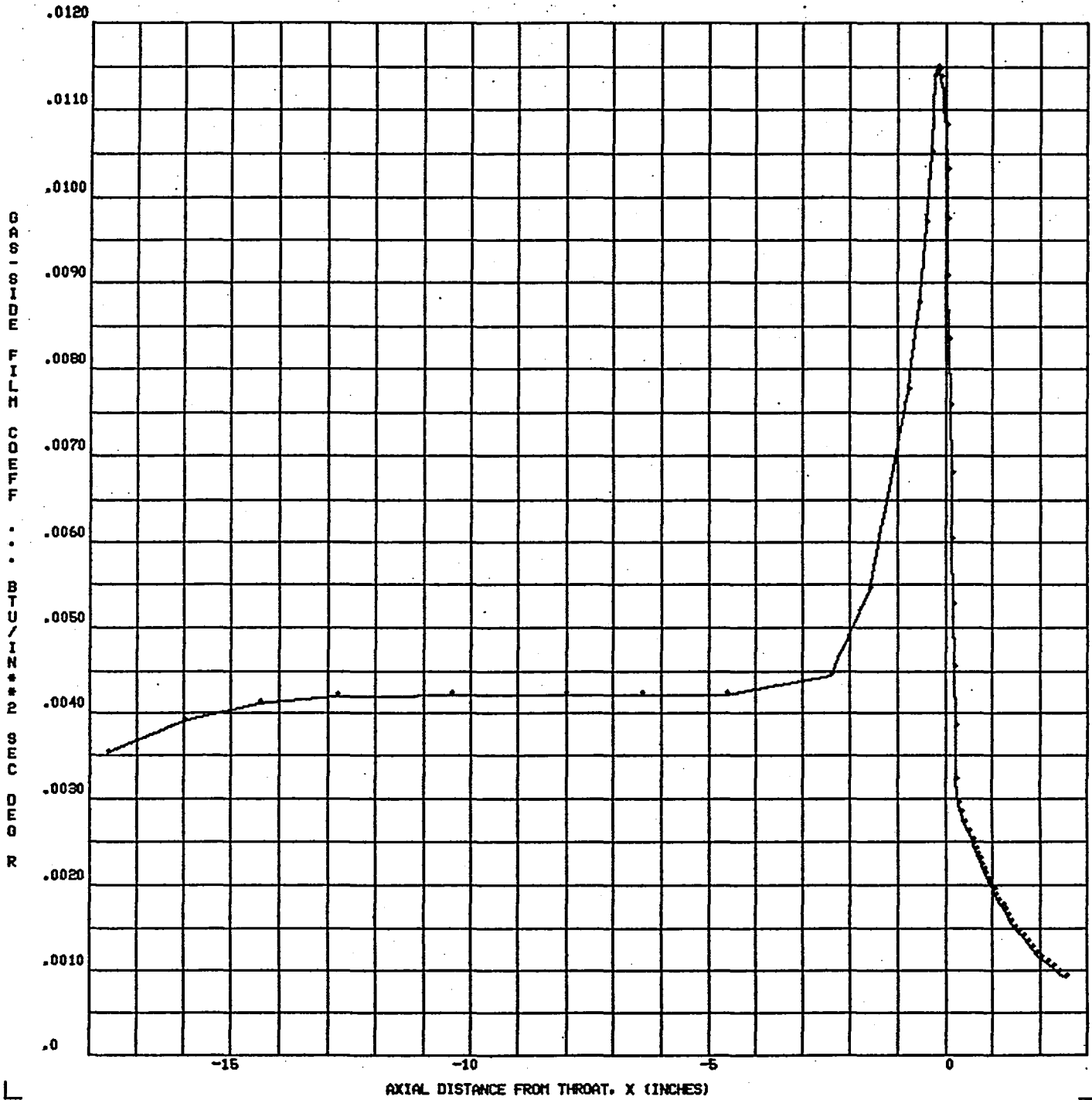

Figure 2-2 Combustor Hot-Gas Heat Transfer Coefficient
7.5K Engine

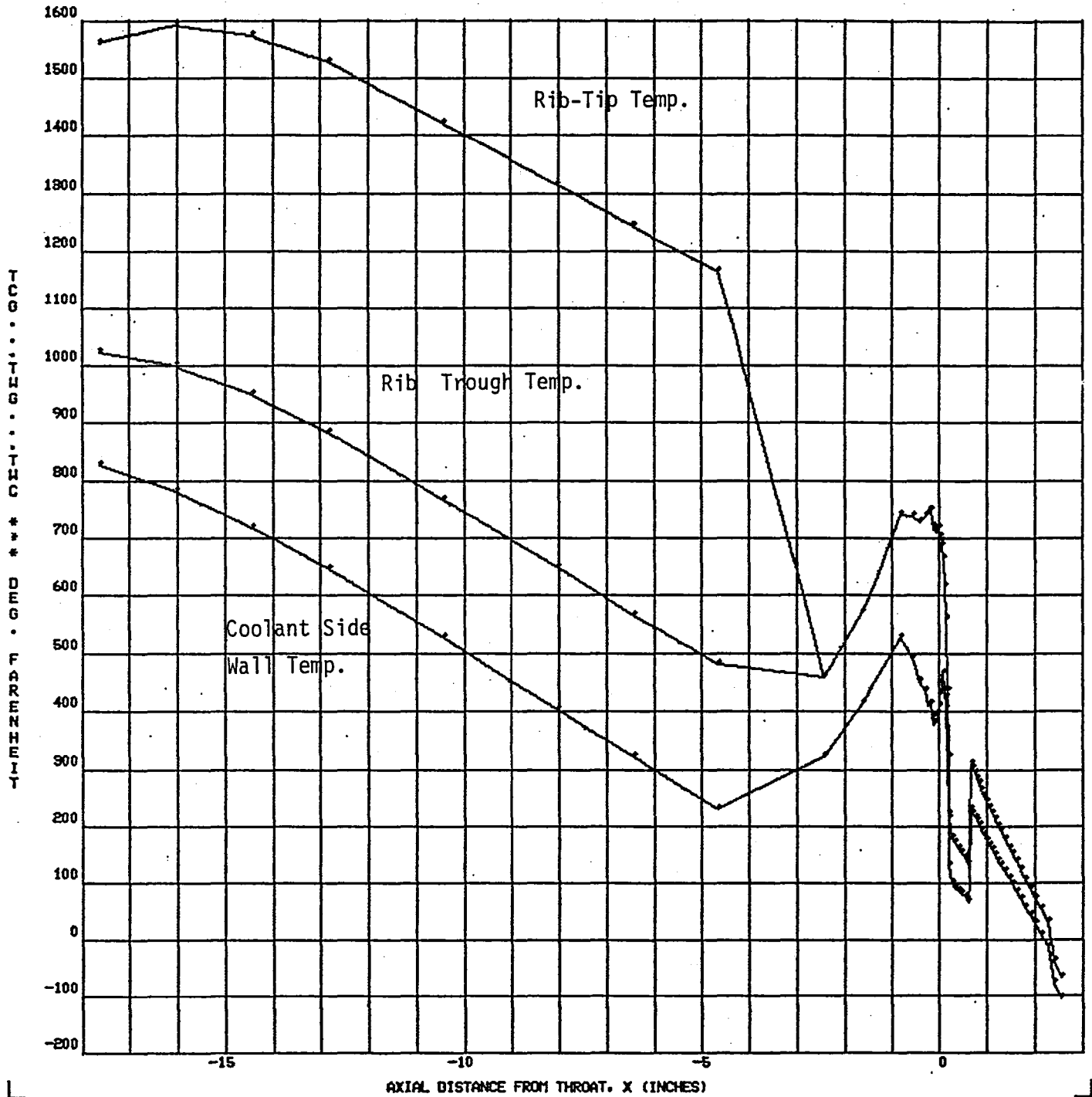

Figure 2-3 Combustor Wall Temperature Profiles,
7.5K Engine

DTV COMBUSTOR, F=7.5KLB, PC=1831PSIA, LCZ=20IN, EC=4, RIBS+FINS

85/02/15
V065790

7

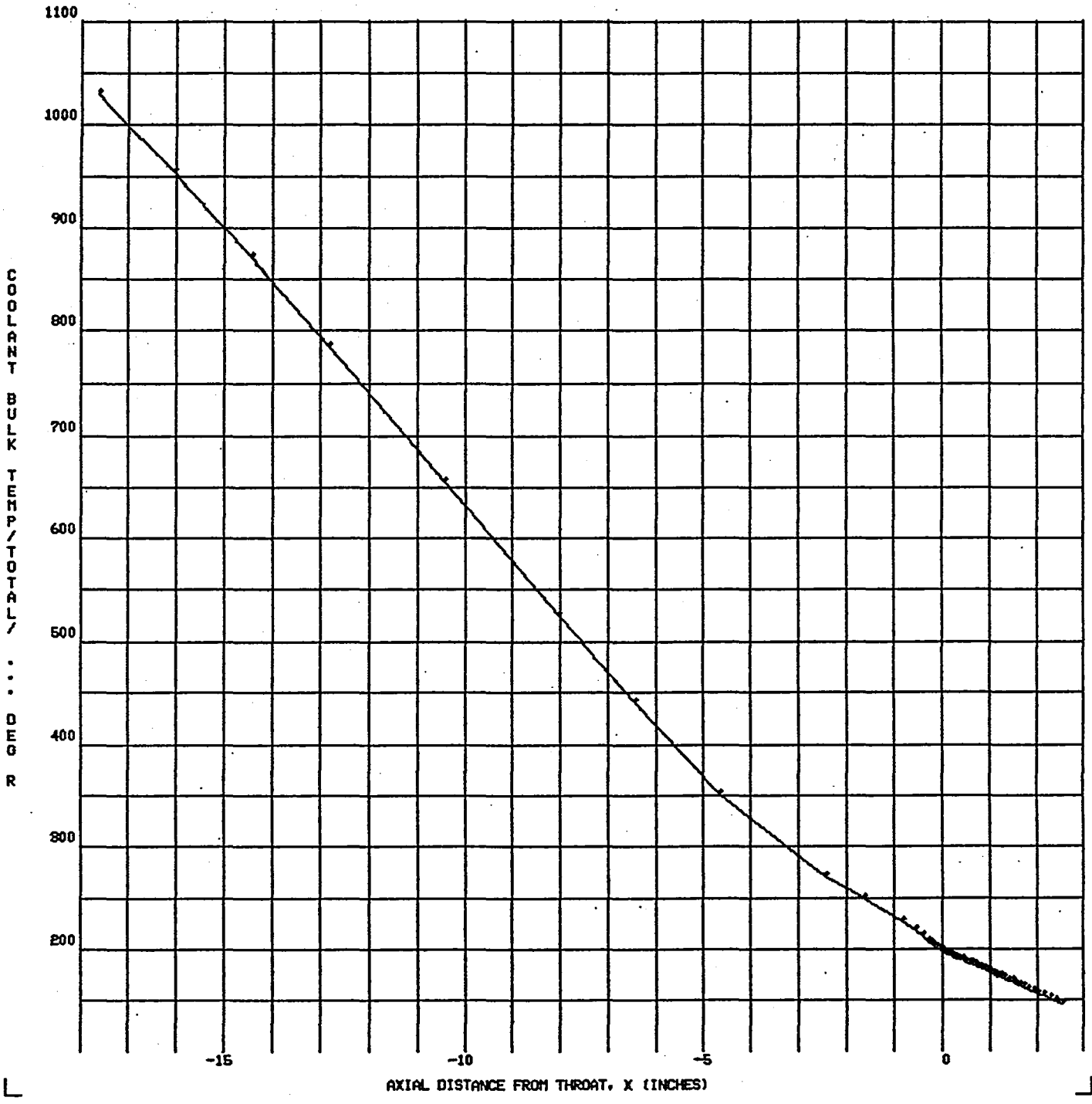

Figure 2-4 Combustor Coolant Bulk Temperature Profile

APPENDIX 3

HYDROGEN REGENERATOR STUDY

An engine operation study was conducted to reinvestigate the possible benefits of a hydrogen regenerator. In review, the regenerator is used to preheat the hydrogen prior to entering the combustor coolant jacket. The energy for the preheat is supplied by the hot turbine exhaust hydrogen before injection. A hydrogen regenerator can be seen in the engine schematic of Figure 21. With this configuration a hotter, more energetic drive gas is supplied to the turbines. The drawback is that with hotter and less dense hydrogen flowing through the combustor and nozzle cooling circuits, the pressure drop increases. This increase in pressure drop offsets the increase in pump exit pressures provided by the turbines being driven by the more energetic hydrogen. If the pressure drop in the combustor coolant jacket could be reduced by a design modification, use of a hydrogen regenerator would become more favorable. Thus for this study, the combustor coolant jacket ΔP was reduced by 20 and 40 percent and the net effects evaluated. To perform these evaluations, the steady-state engine design optimization computer program was used. For this study, the heat load of the regenerator was included as one of the several independent variables in the optimization of performance (specific impulse). All cases included soft wear ring seals and advanced turbomachinery limits. For the baseline case in which no decreases in coolant jacket ΔP were made, the optimum engine configuration did not include a recuperator (heat load = 0 BTU/sec). Thus without combustor coolant circuit modifications, there is no benefit from a recuperator. By decreasing the coolant jacket pressure drop 20 and 40 percent very slight performance improvements of +0.2 sec I_{sp} and increases in chamber pressure of 50 and 60 psi, respectively, were realized. These results are summarized in Table 21. The conclusion drawn from this study is that with the added complexity and engine weight the minimal increases in performance do not warrant the use of a hydrogen recuperator even if major reductions in the combustor coolant jacket pressure drop were possible.

3-2
RI/RD86-116

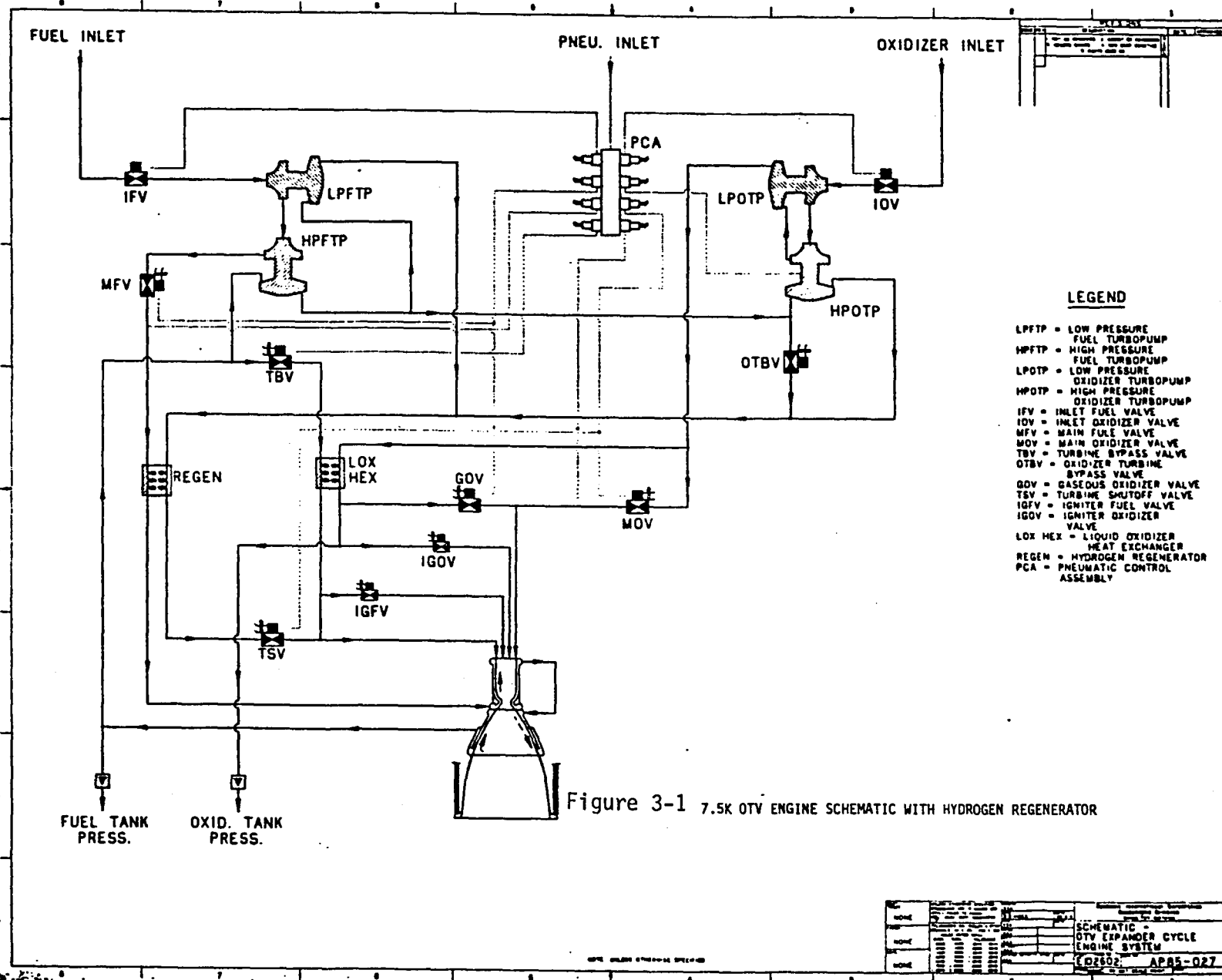

COPYING INFORMATION AVAILABLE

TABLE 3-1
7.5K HYDROGEN REGENERATOR STUDY

		BASELINE CASE = 100% $\Delta P_{\text{COMB.}}$	$\Delta P_{\text{COMB.}} = 80\%$	$\Delta P_{\text{COMB.}} = 60\%$
$Q_{\text{REGEN.}}$	BTU SEC	0	97.9	1187
I_{SP}	SEC	490.4	490.6	490.6
P_{C}	PSIA	1831	1881	1890
$\Delta P_{\text{COMB.}}$	PSI	1202	1133	1789
MAIN FUEL TURBINE INLET TEMP.	$^{\circ}\text{R}$	1119	1127	1265
$\eta_{\text{MAIN FUEL}}$ TURBINE	%	61.9	63.0	63.0
FUEL PUMP EXIT PRESSURE	PSIA	7733	7726	8293

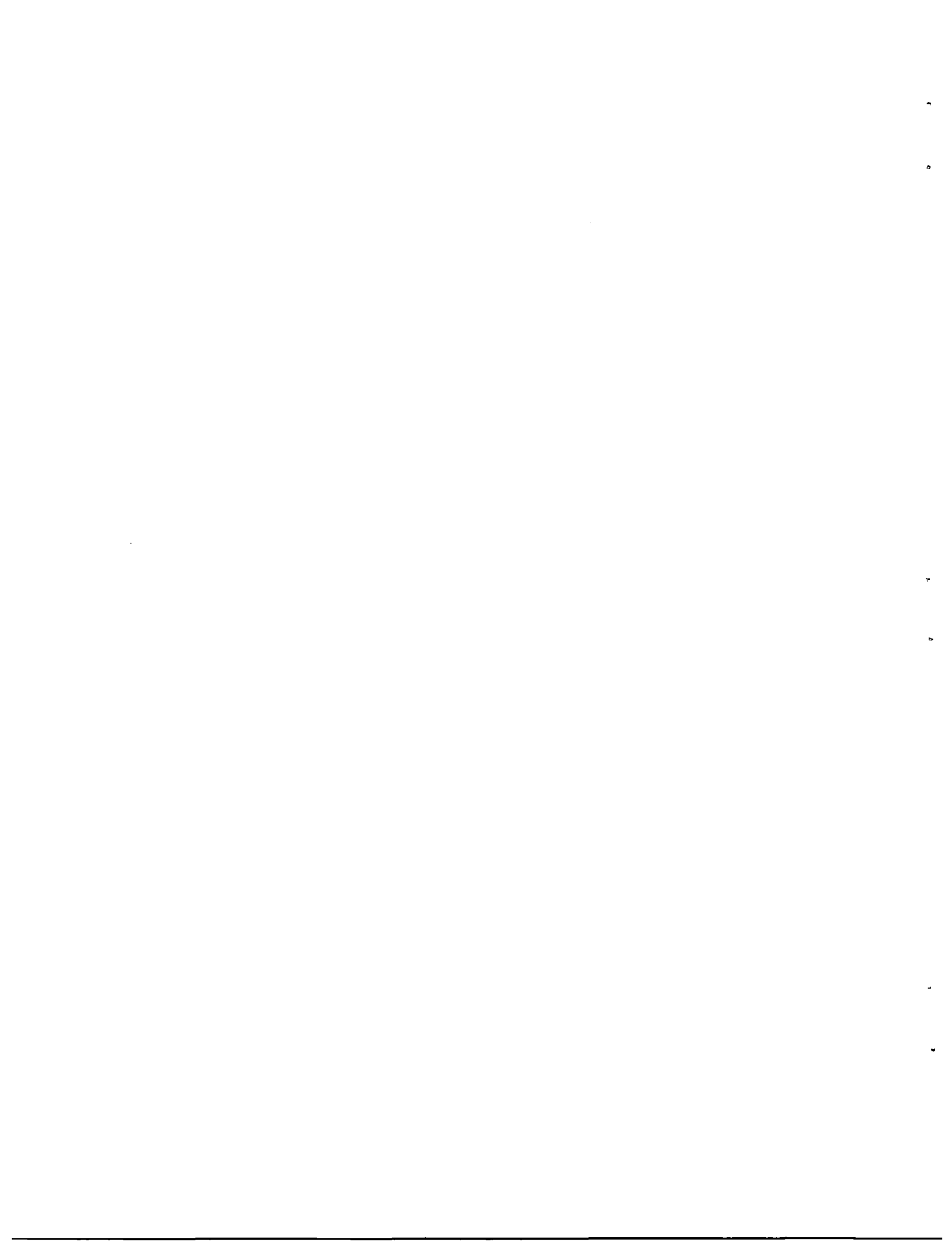

APPENDIX 4
THRUST STUDY
OTV ENGINE PERFORMANCE PARAMETRICS
CONSTANT NOZZLE AREA RATIO OF 1000:1
NOZZLE PERCENT LENGTH OF 90
 $\epsilon_{\text{BREAKPOINT}} = 450$

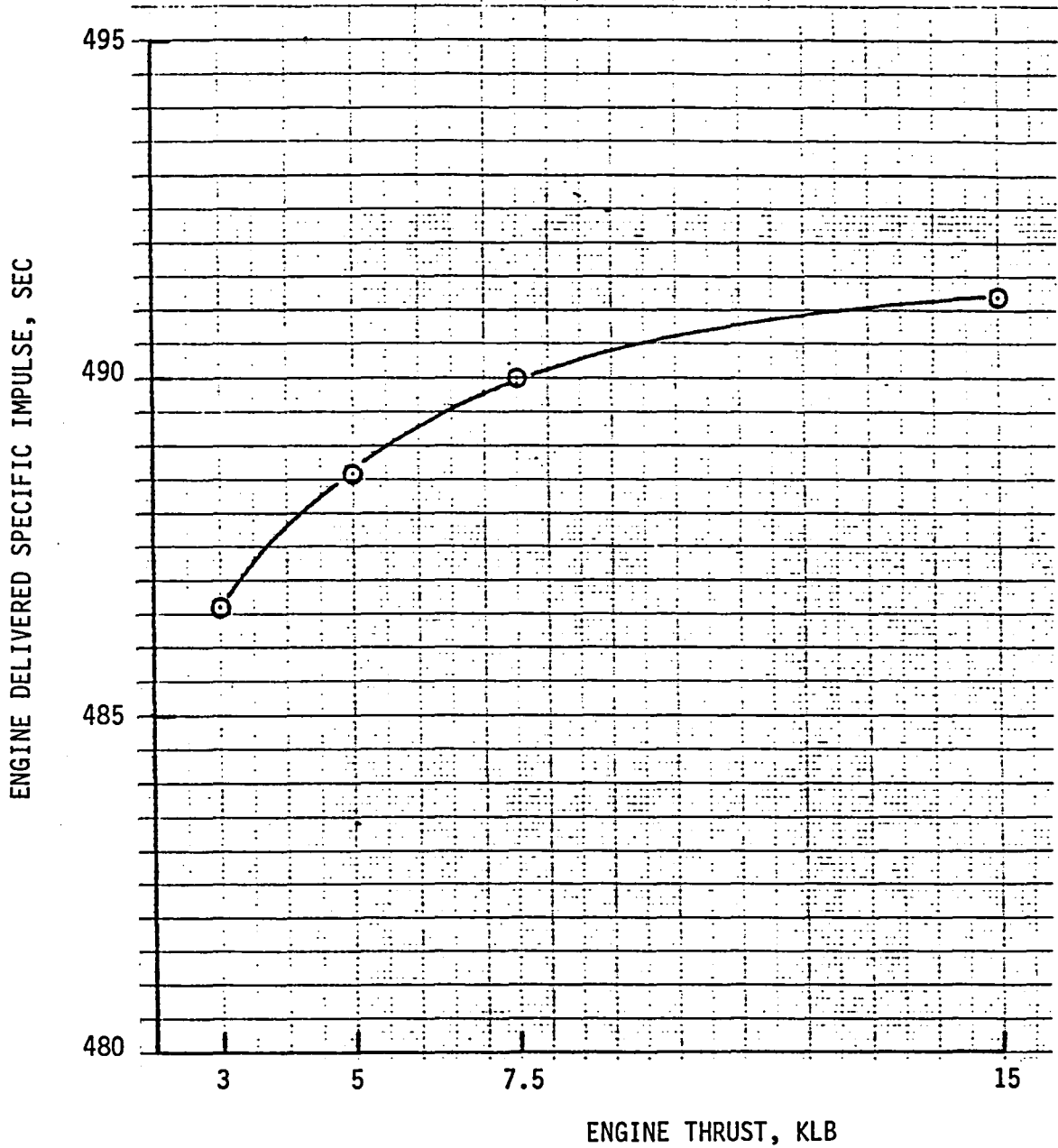

Figure 4-1

OTV ENGINE WEIGHT PARAMETRICS
CONSTANT NOZZLE AREA RATIO OF 1000:1
NOZZLE PERCENT LENGTH OF 90
 $\epsilon_{\text{BREAKPOINT}} = 450$

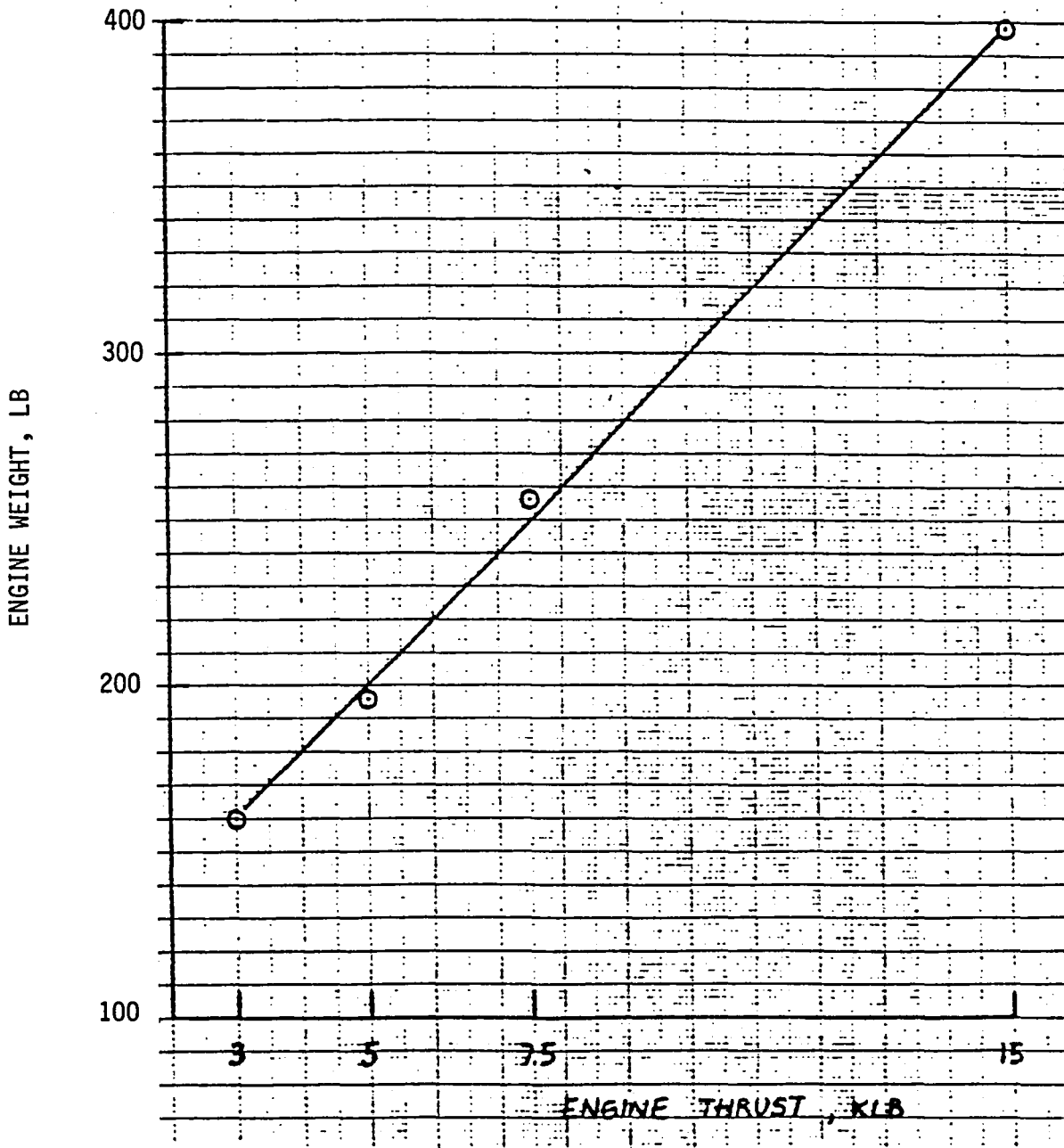

Figure 4-2

OTV CLUSTER ENGINE WEIGHT PARAMETRICS

TOTAL THRUST 15K

CONSTANT NOZZLE AREA RATIO OF 1000:1

NOZZLE PERCENT LENGTH OF 90

$\epsilon_{\text{BREAKPOINT}} = 450$

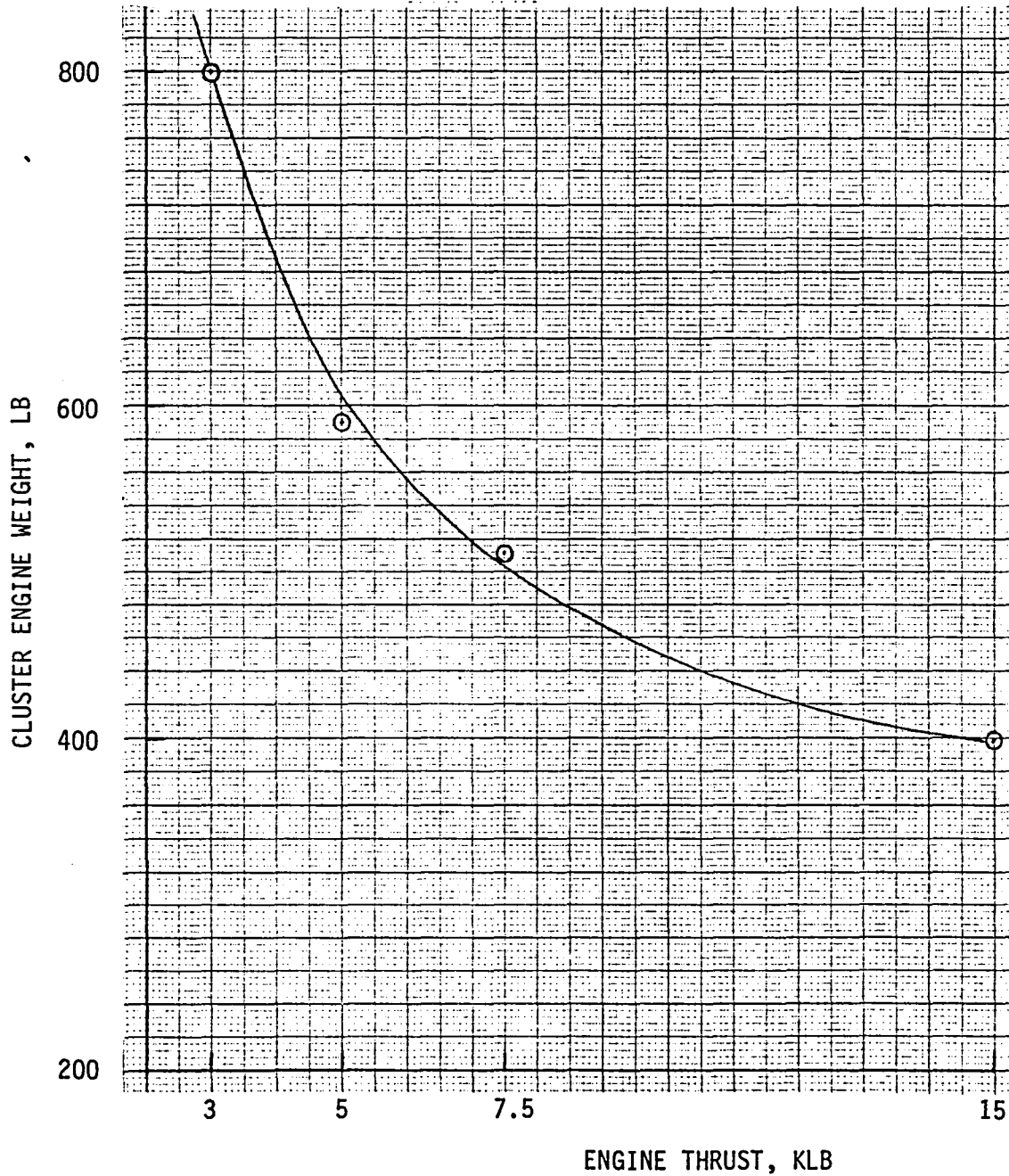

Figure 4-3

OTV PAYLOAD GAIN PARAMETRICS
 CONSTANT NOZZLE AREA RATIO OF 1000:1
 NOZZLE PERCENT LENGTH OF 90
 ϵ BREAKPOINT = 450

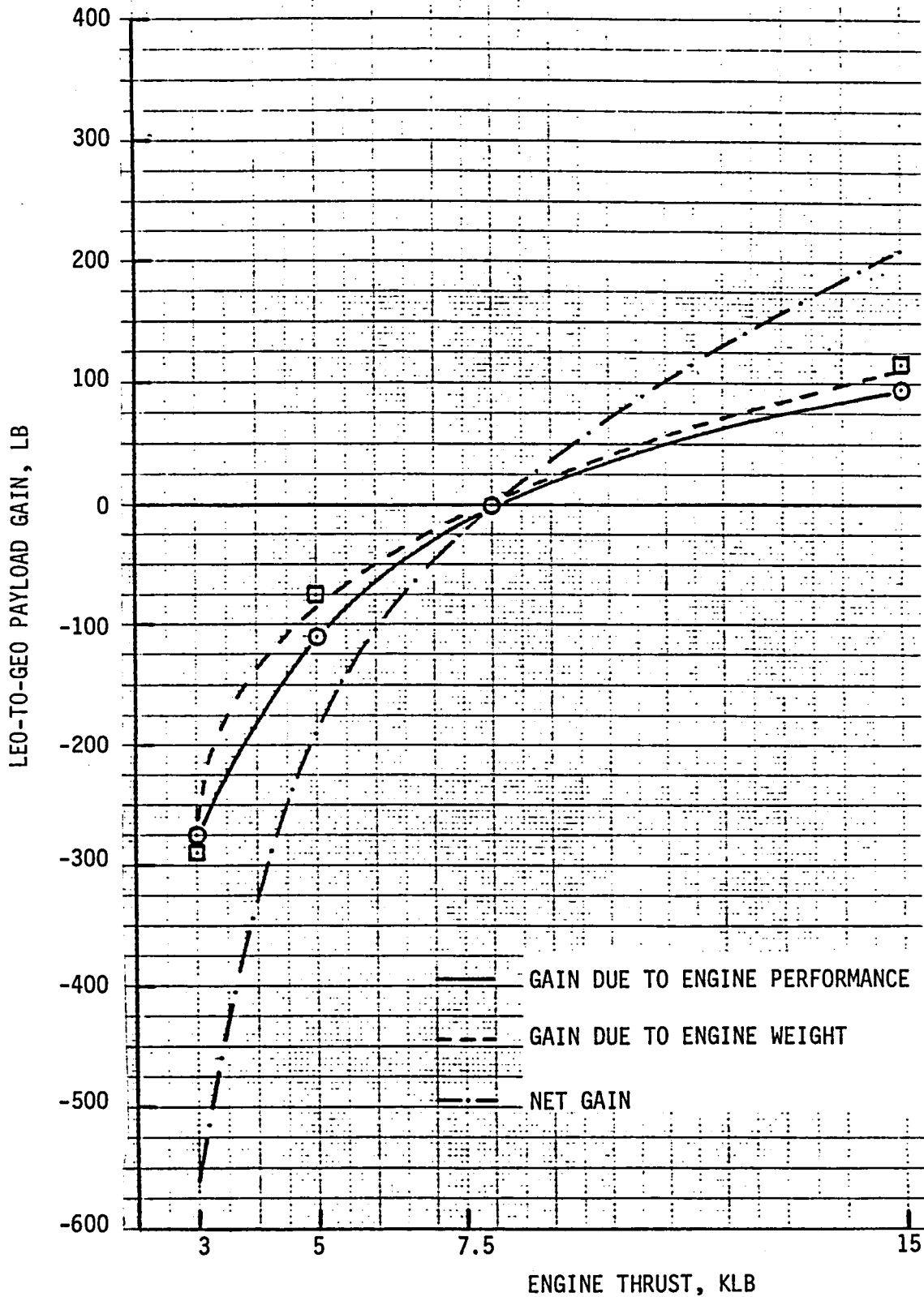

Figure 4-4

OTV CHAMBER PRESSURE PARAMETRICS
FIXED NOZZLE AREA RATIO OF 1000:1
NOZZLE PERCENT LENGTH OF 90

$$\epsilon_{\text{BREAKPOINT}} = 450$$

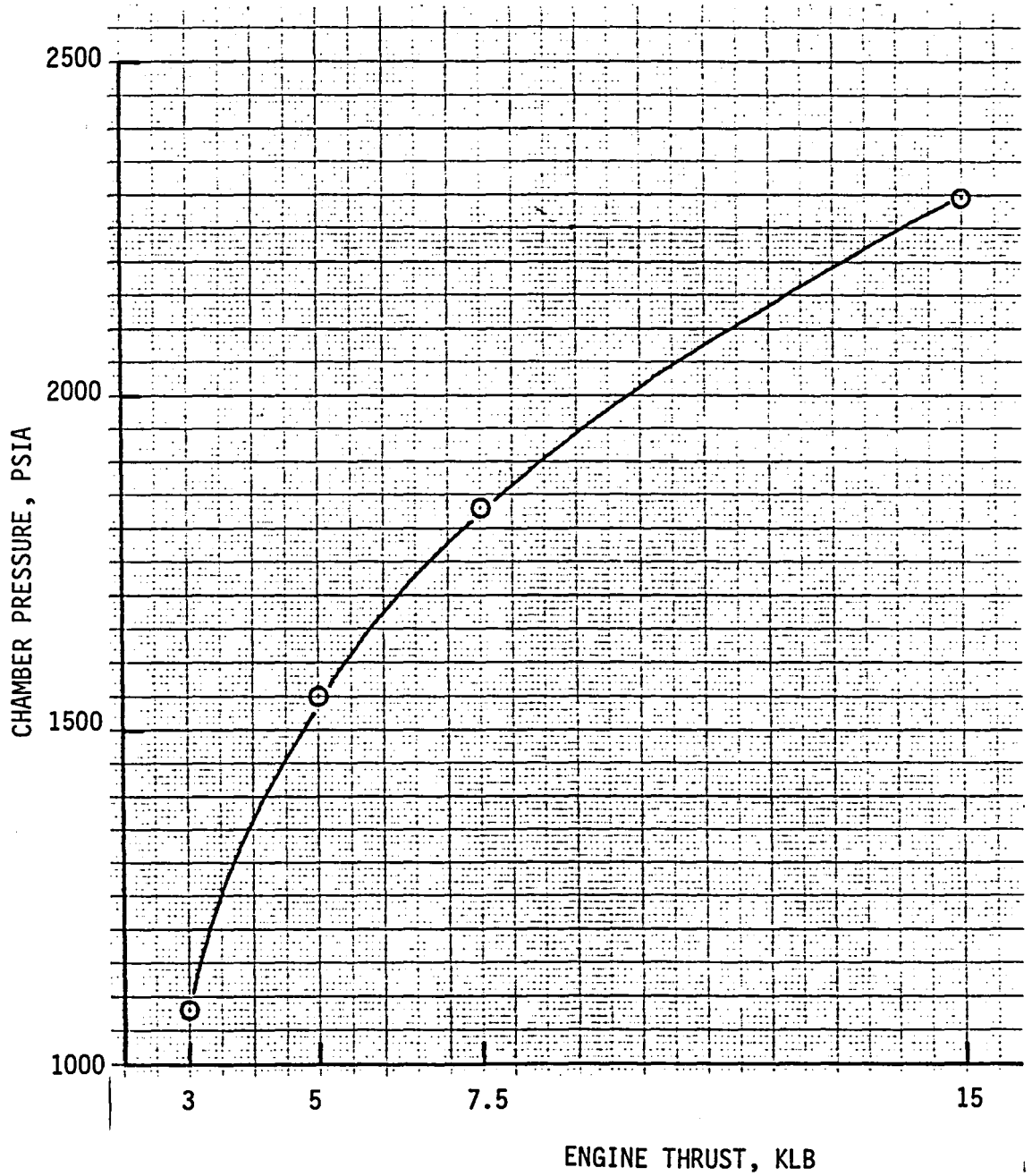

Figure 4-5

OTV ENGINE LENGTH PARAMETRICS
CONSTANT NOZZLE AREA RATIO OF 1000:1
NOZZLE PERCENT LENGTH OF 90
 $\epsilon_{\text{BREAKPOINT}} = 450$

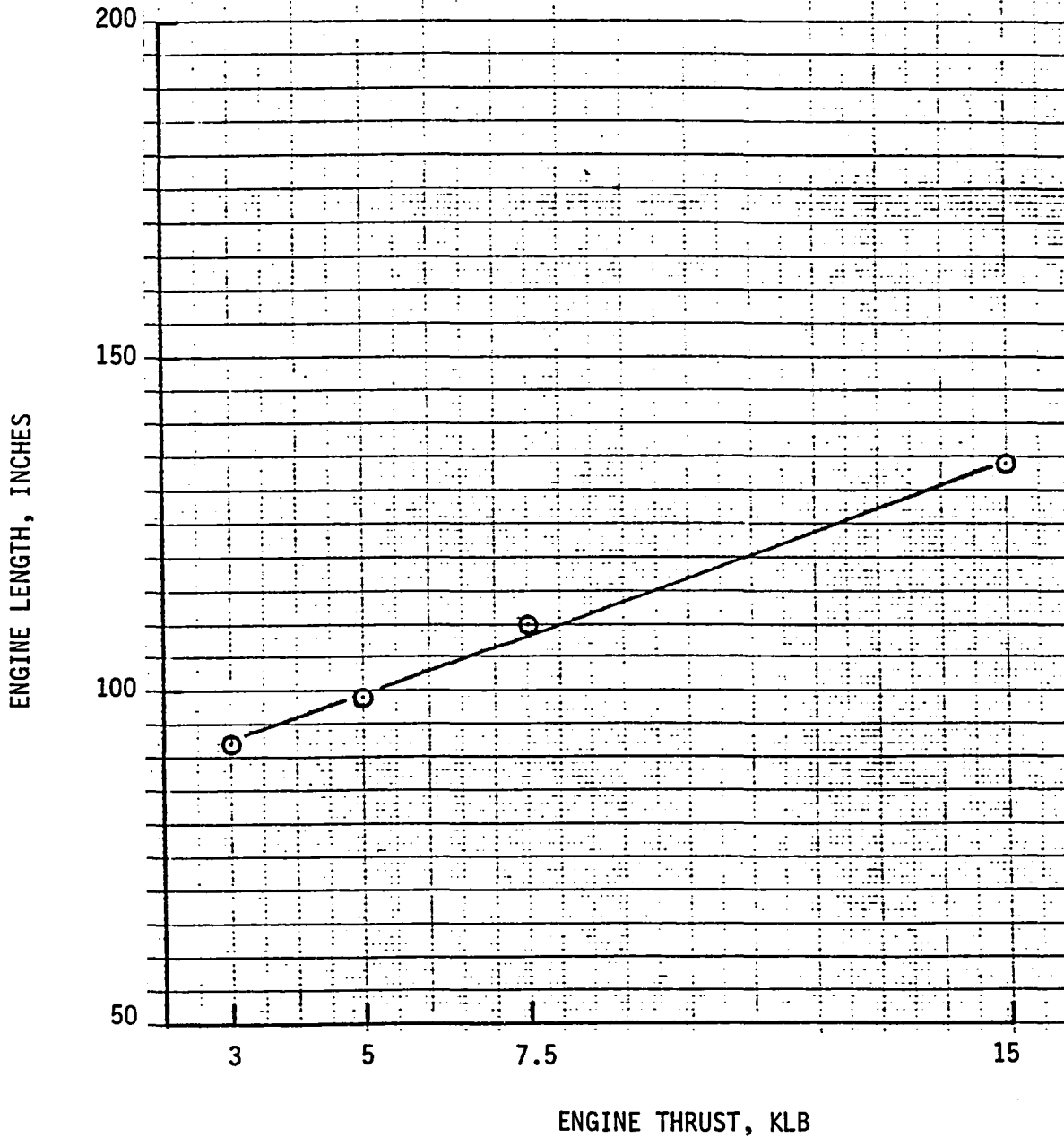

Figure 4-6

OTV ENGINE DIAMETER PARAMETRICS
CONSTANT NOZZLE AREA RATIO OF 1000:1
NOZZLE PERCENT LENGTH OF 90
 $\epsilon_{\text{BREAKPOINT}} = 450$

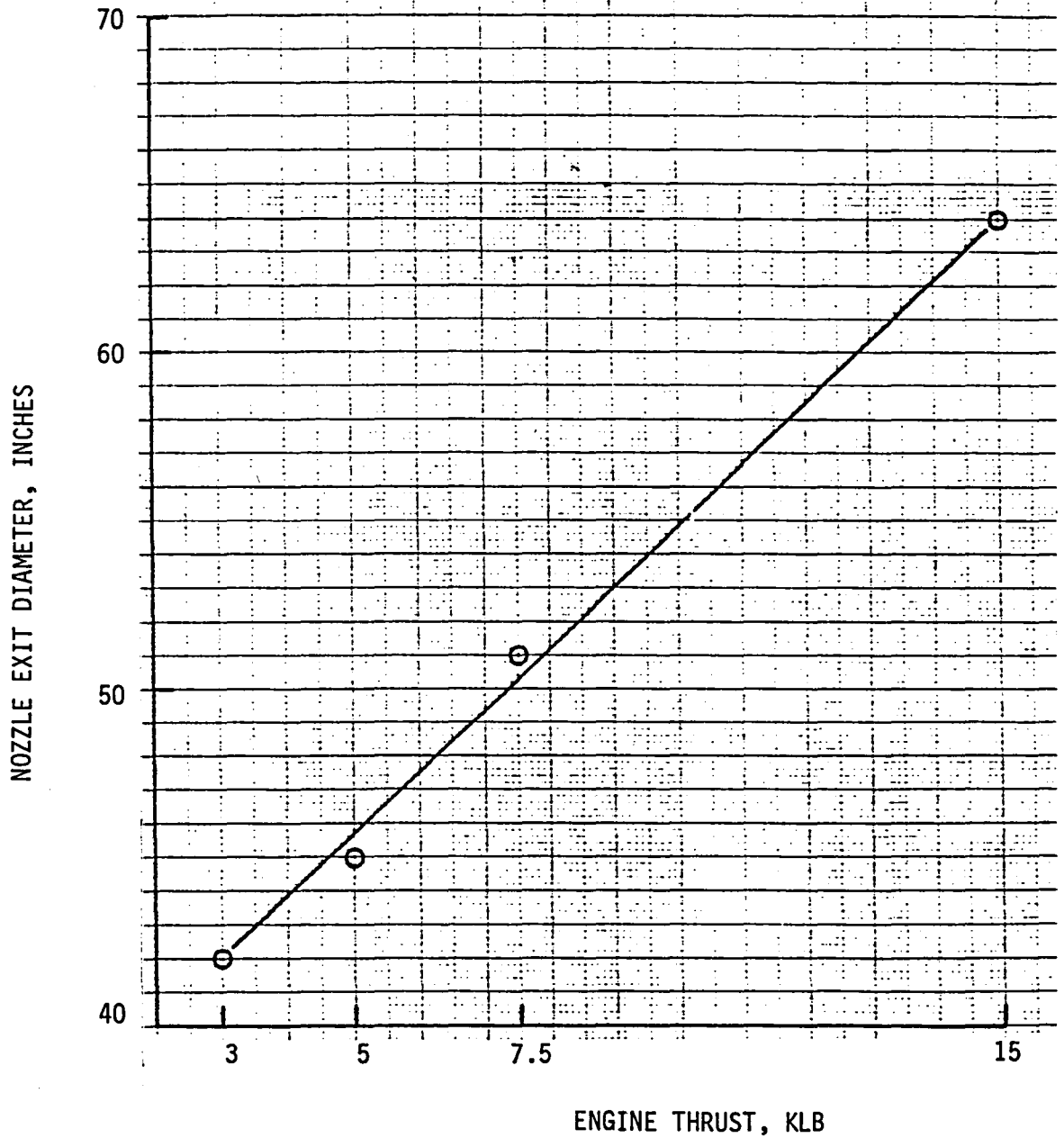

Figure 4-7

OTV TURBOPUMP EFFICIENCY PARAMETRICS
AT CONSTANT NOZZLE AREA RATIO OF 1000:1
AND NOZZLE PERCENT LENGTH OF 90

$\epsilon_{\text{BREAKPOINT}} = 450$

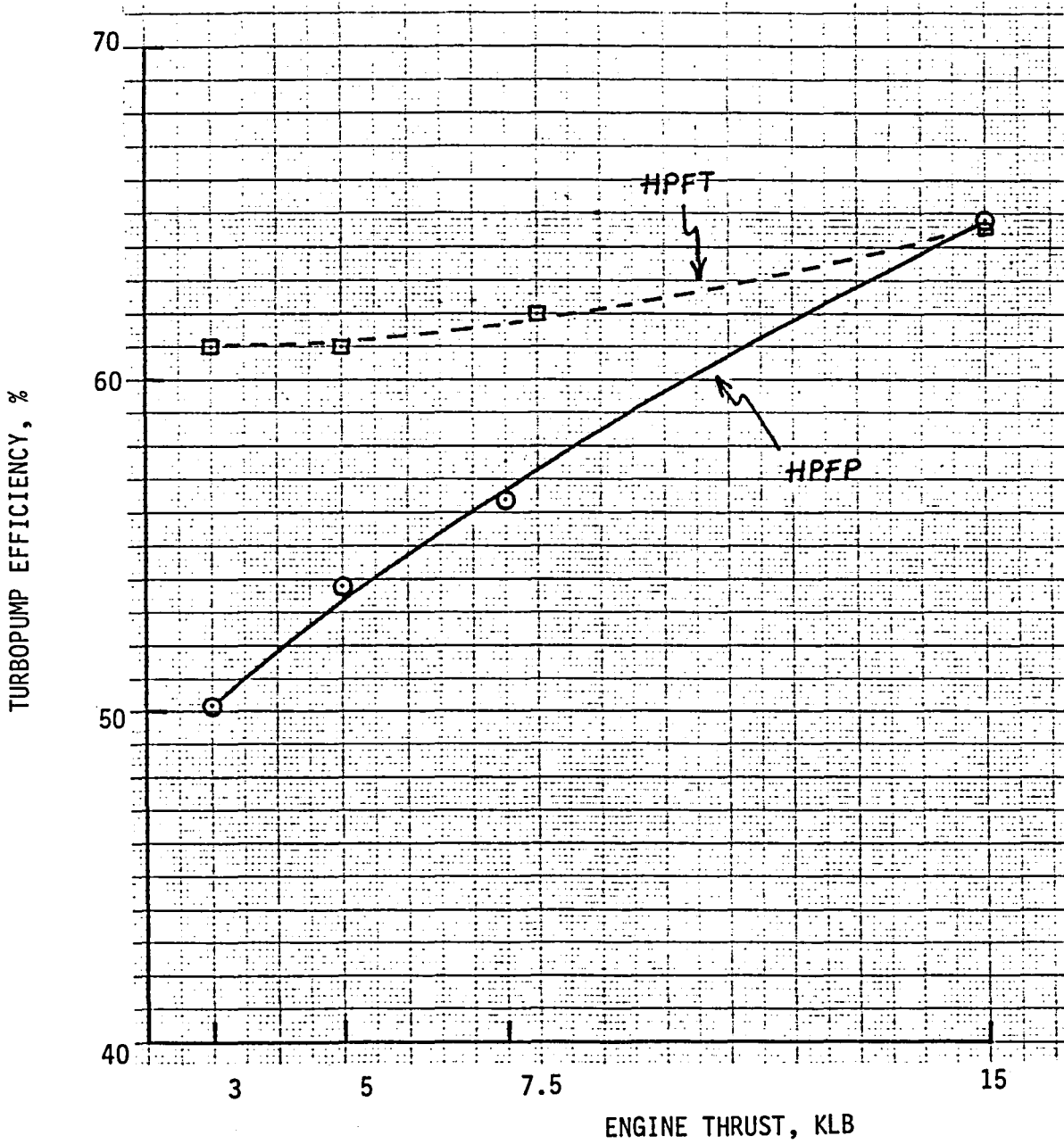

Figure 4-8

OTV FMEA

SYSTEM: Turbine and Turbine /05 ITEM NO. 03 NAME: High Pressure P/N REVISION 0 ANALYSIS DATE: 12/84 PAGE 1 OF 1
Drive Systems Oxidizer Turbine

REF. NO.	PHASE	FAILURE MODE	FAILURE EFFECTS	FAILURE CAUSE	ICHM OR OTHER MEANS OF DETECTION	RESPONSE TIME	CRIT. NO.	CIL ITEM
050301	PI, MS, TM, AB	Performance degradation	Controller will increase inlet pressure and gas flow rate.	Increased tip seal clearance, gas seal wear.	Chamber pressure and flows, mixture ratio (algo), torque-meter.	Adequate	3	
050302	Same	Same	Degradation exceeds available power reserve.	Same	HPOP discharge pressure below minimum redline.	Adequate	2/B	
050303	PI, MS, TM, AB	Excessive vibration	Progression may lead to fragmentation.	Turbine wheel rubbing or imbalance, bearing wear, prolonged operation at critical speed.	Accelerometers, fiber-optic deflectometer, torquemeter; - redline exceeded.	Adequate	1/A	
050304	Same	Same	Reduced power level operation alleviates problem.	Same	Same except redline not exceeded.	Adequate	1/C	
050305	PI, MS, TM, AB, SD	Turbine blade or wheel failure, failure of stationary part interfering with turbine, housing failure.	Progression may lead to uncontained damage and fragmentation.	High cycle fatigue, surface cracks, contamination.	None	Inadequate	1	X
050306	ES, THI, PI, MS, TM, AB, SB	LOX from pump and turbine drive gas mix.	Fire - major uncontained damage.	Excessive seal leakage, and failure of intermediate seal purge.	Seal purge pressure failure is mandatory engine shutdown.	Inadequate	1M	X

RI/RD86-116

5-1

APPENDIX 5
SAMPLE FMEA OUTPUT.

0026d(14)/emh

OTV FMEA

SYSTEM: Oxidizer Feed System /06 ITEM NO. 02 NAME: Low Pressure Oxidizer Pump P/N _____ REVISION 0 ANALYSIS DATE: 12/84 PAGE 1 OF 1

REF. NO.	PHASE	FAILURE MODE	FAILURE EFFECTS	FAILURE CAUSE	ICHM OR OTHER MEANS OF DETECTION	RESPONSE TIME	CRIT. NO.	CIL ITEM
060201	PI, MS, TH, AB	Performance degradation.	Controller will increase turbine power for minor degradation.	Excessive clearances or seal leakage, blocked internal passages, wear, erosion, cavitation, low NPSH.	Chamber pressure, flows and mixture ratio. (Algo)	Adequate	3	
060202	Same	Same	Degradation exceeds available power reserve.	Same	Discharge pressure below redline.	Adequate	2/B	
060203	PI, MS, TH, AB	Excessive vibration.	Progression may lead to significant contained damage.	Rotating group rubbing or imbalance, bearing wear, loss of bearing coolant flow, prolonged operation at critical speed.	Accelerometers, fiber-optic deflectometer, torque-meter, redline exceeded.	Adequate	2/B	
060204	Same	Same	Reduced power level operation alleviates problem.	Same	Same except redline not exceeded.	Adequate	2/C	
060205	PI, MS, TH, AB,	Excessive speed.	Progression may lead to significant contained damage.	Cavitation, abrupt reduction in load.	Tachometer redline exceeded.	Adequate	2/B	
060206	PI, MS, TH, AB, SD	Piece part failure of rotating group, bearing failure, failure of piece part resulting in interference with rotating group, housing failure.	May result in significant contained damage.	High cycle fatigue or surface imperfection + fatigue, contamination.	None	Inadequate	2	X
060207	PI, MS, TH, AB, SD	Internal fire.	May result in uncontained damage.	Rubbing, fretting, or structural failure of internal parts (impact).	None	Inadequate	1	X

0026d/bjm

5-2
RI/RD86-116

APPENDIX 6 TRANSIENT ENGINE SIMULATION

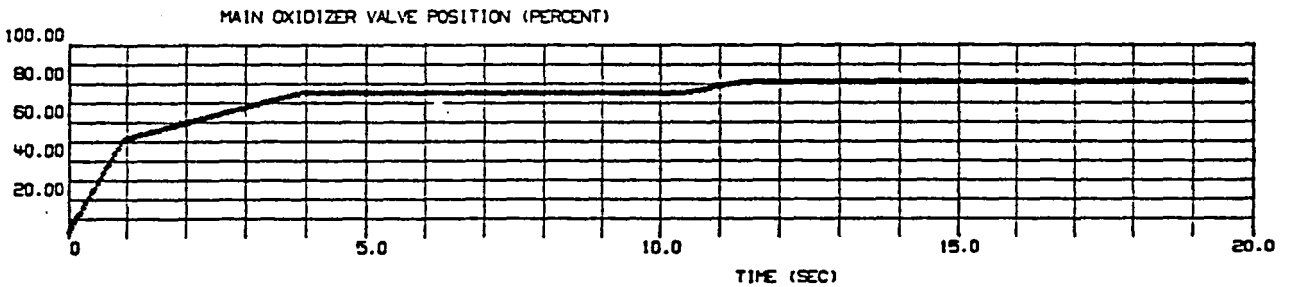
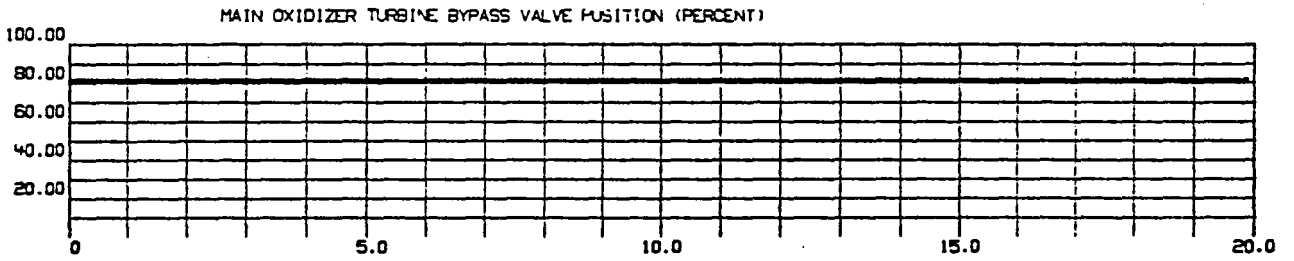
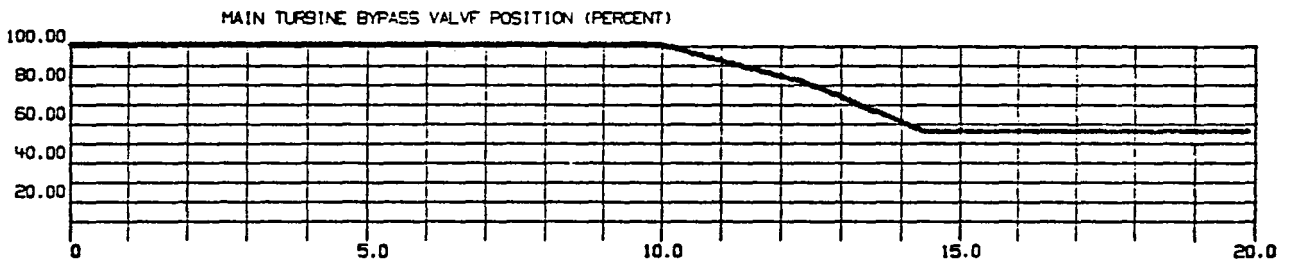
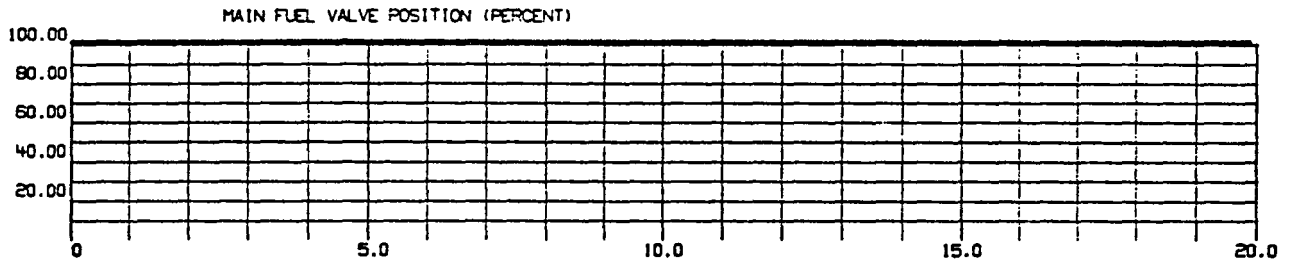
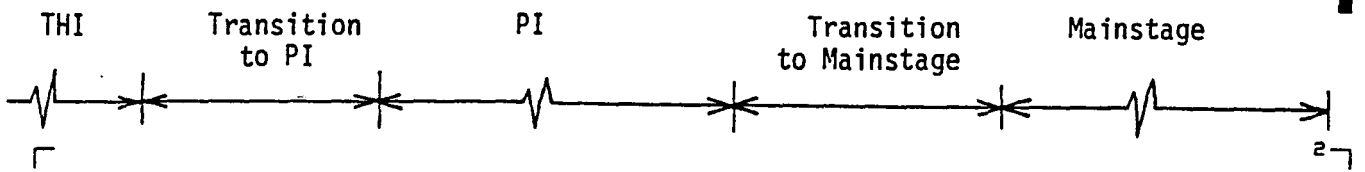

Figure 6-1 Valve Sequences - 7.5K Engine Start

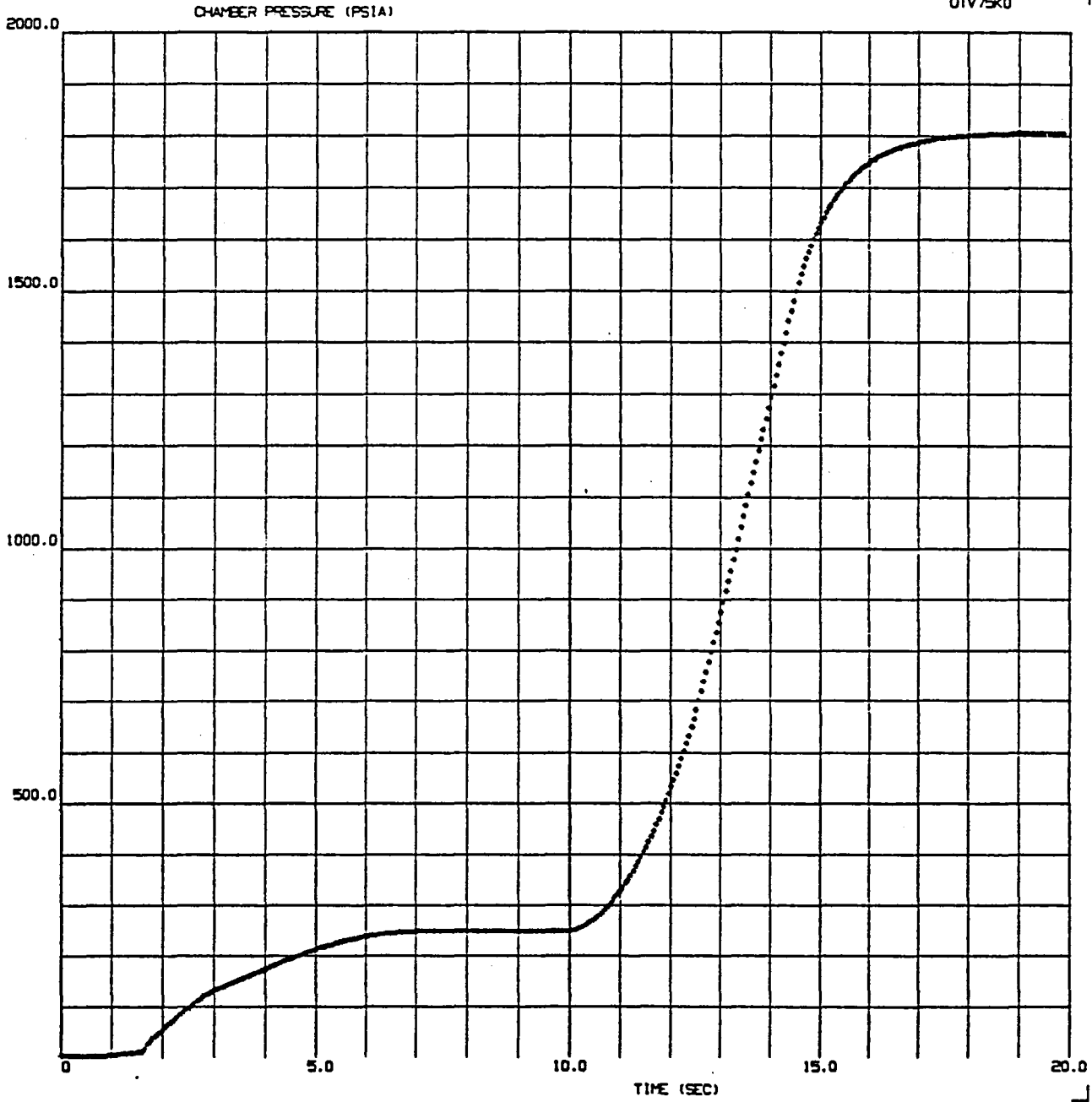

Figure 6-2 Chamber Pressure - 7.5K Engine Start

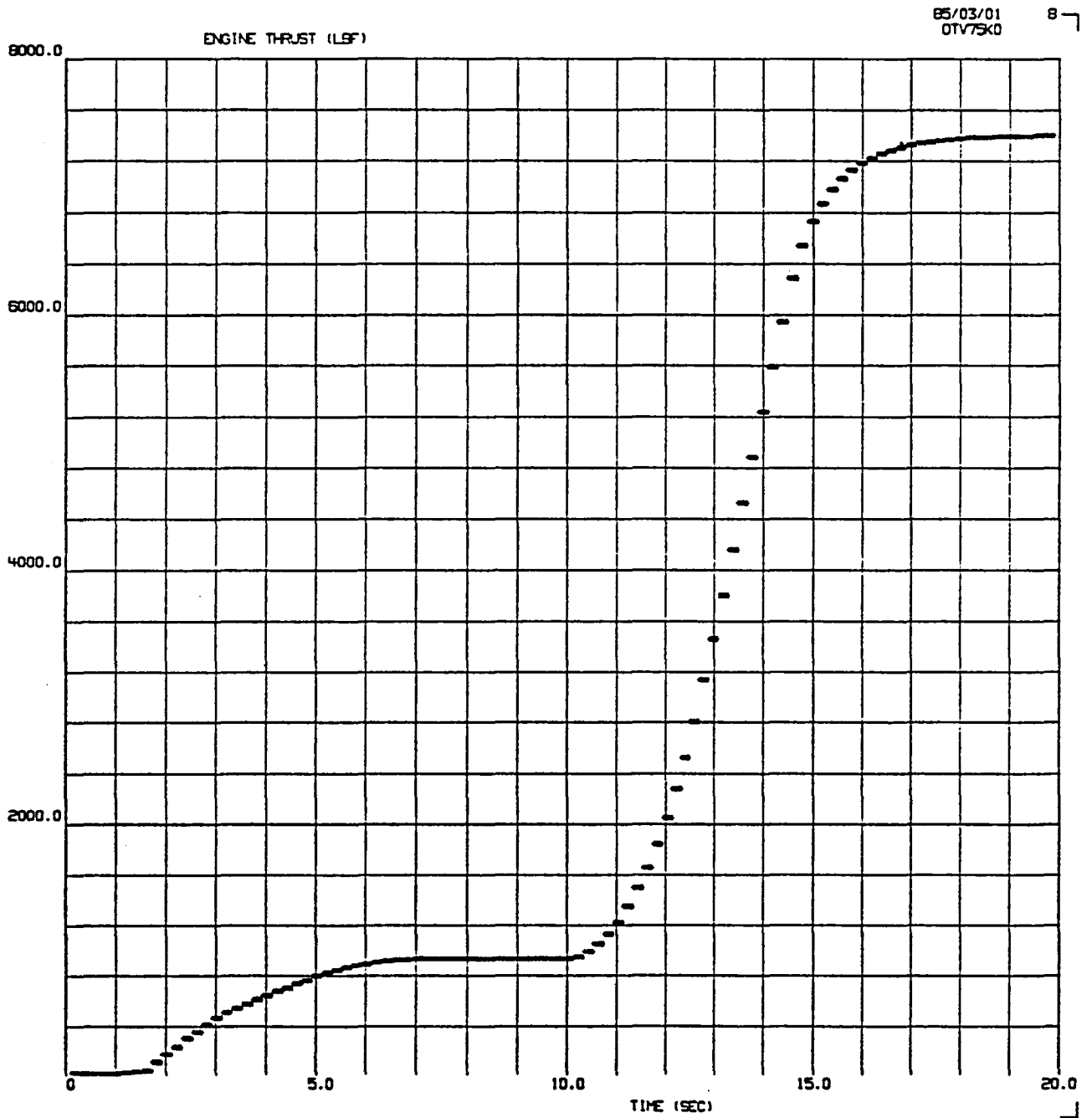

Figure 6-3 Engine Thrust - 7.5K Engine Start

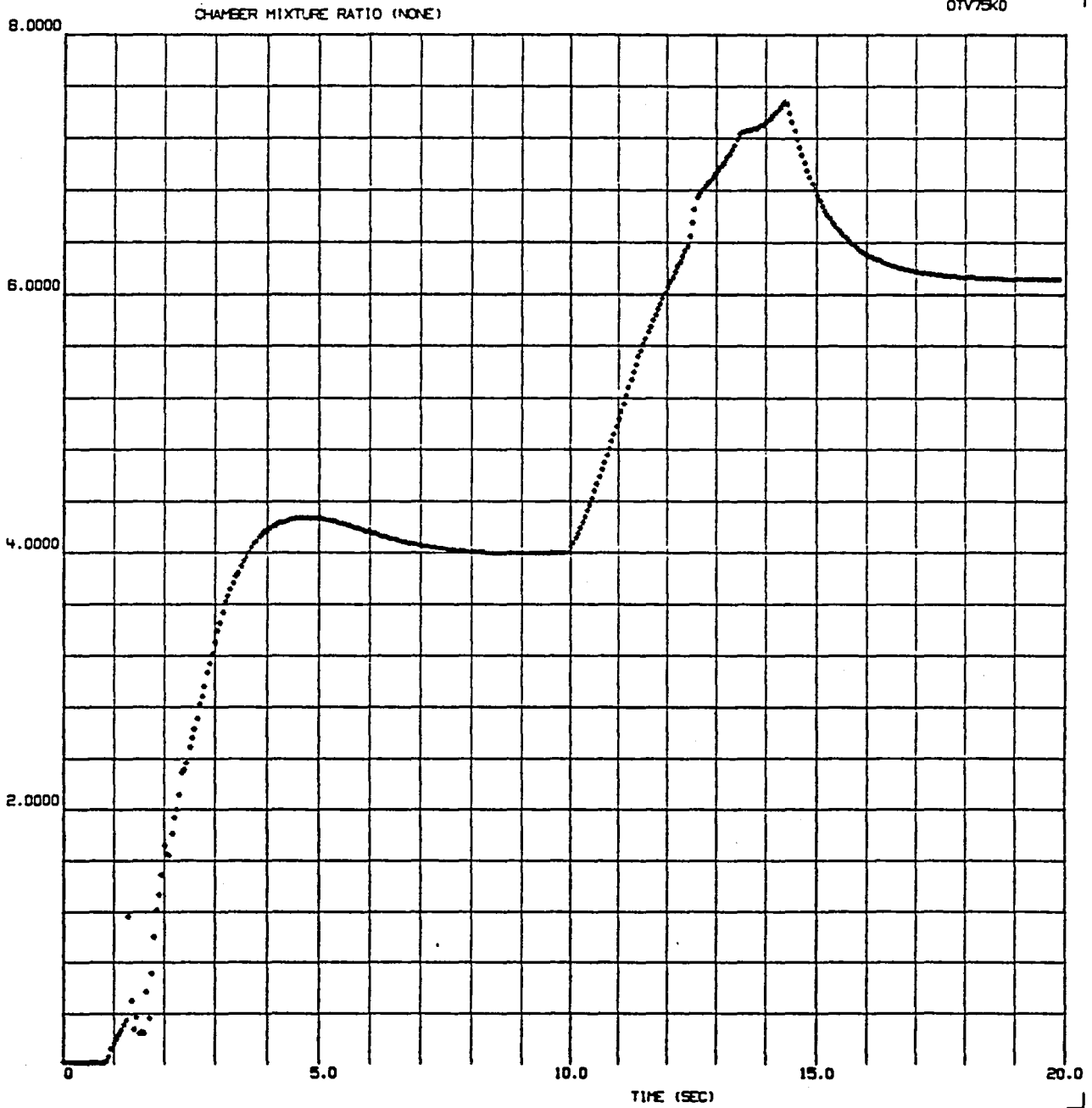

Figure 6-4 Chamber Mixture Ratio - 7.5K Engine Start

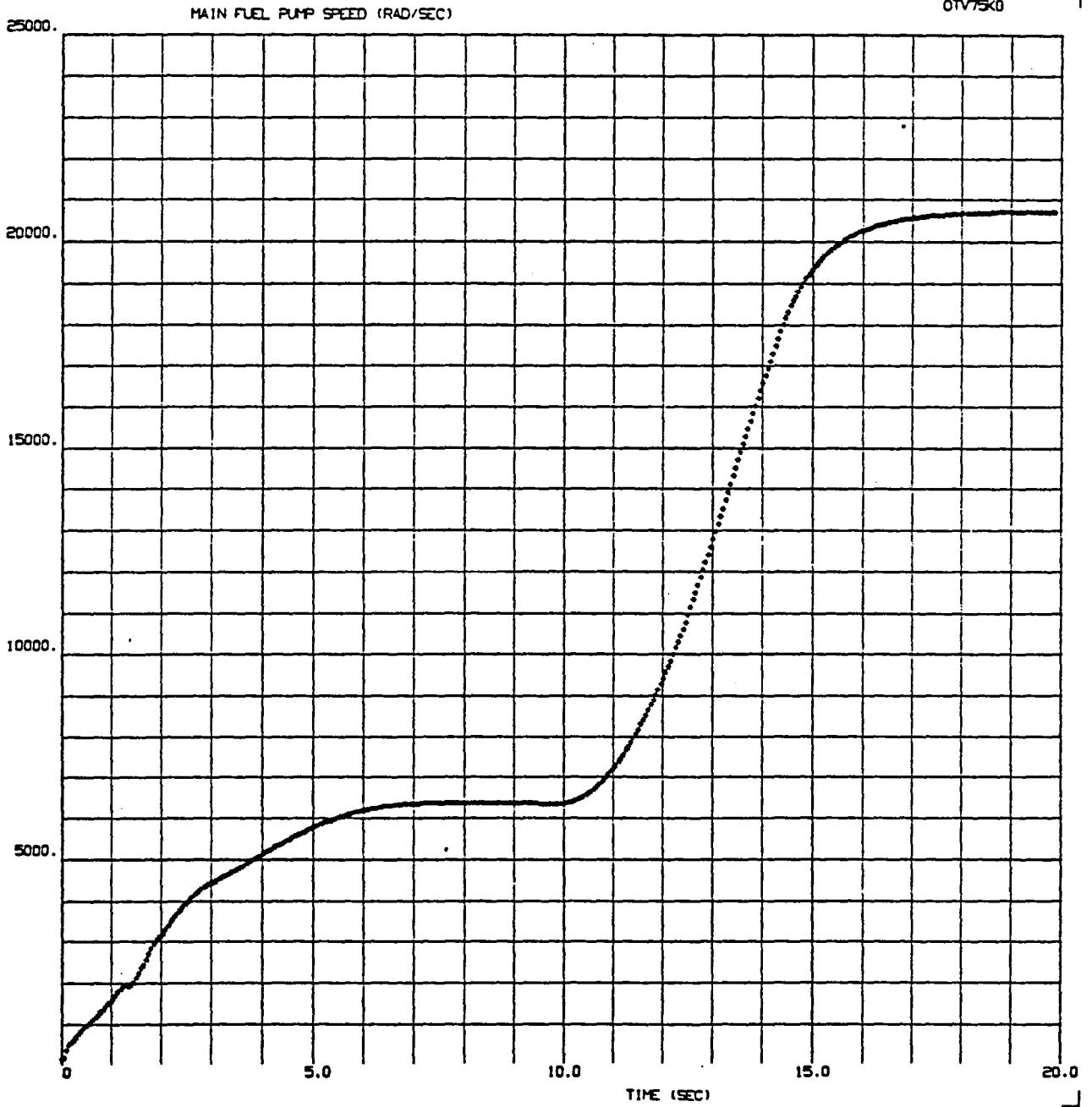

Figure 6-5 Main Fuel Pump Speed - 7.5K Engine Start

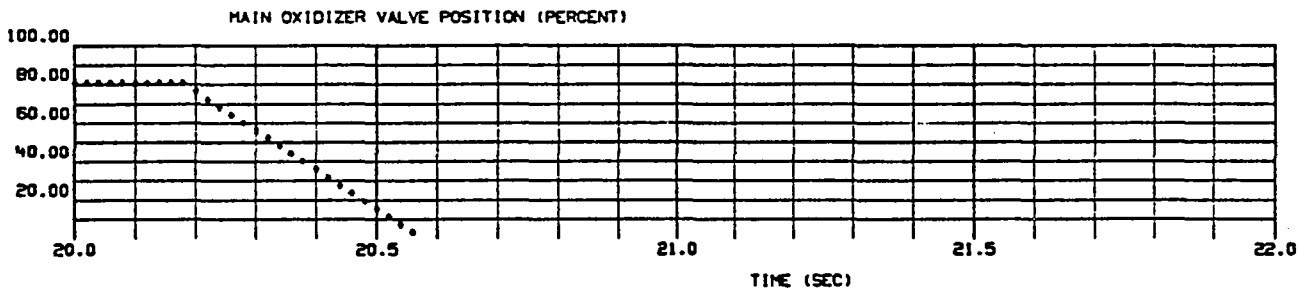
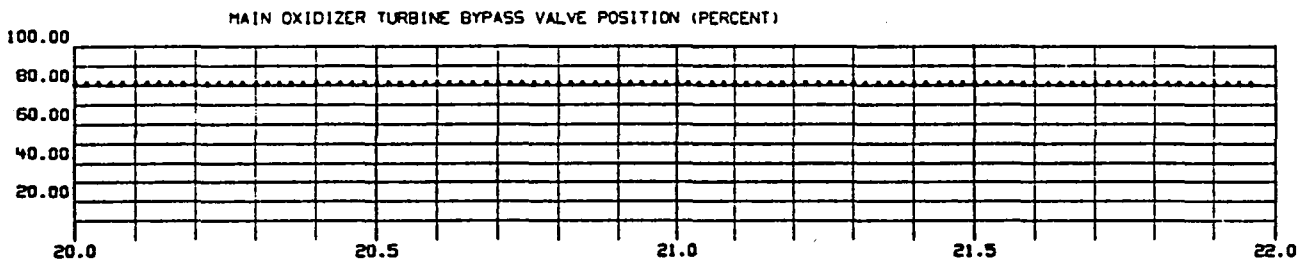
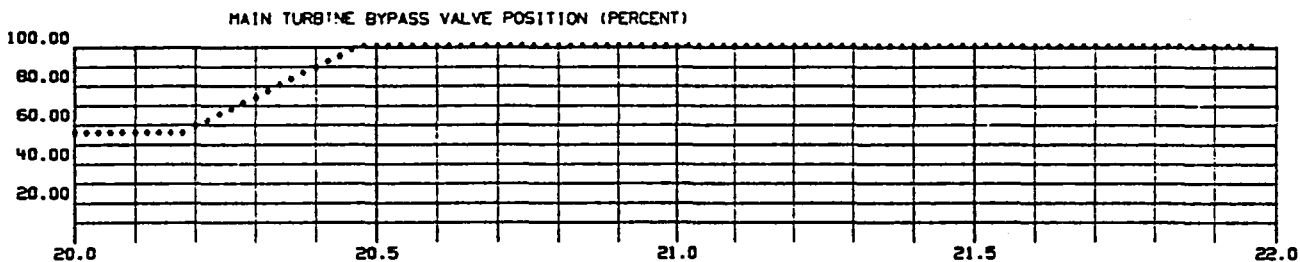
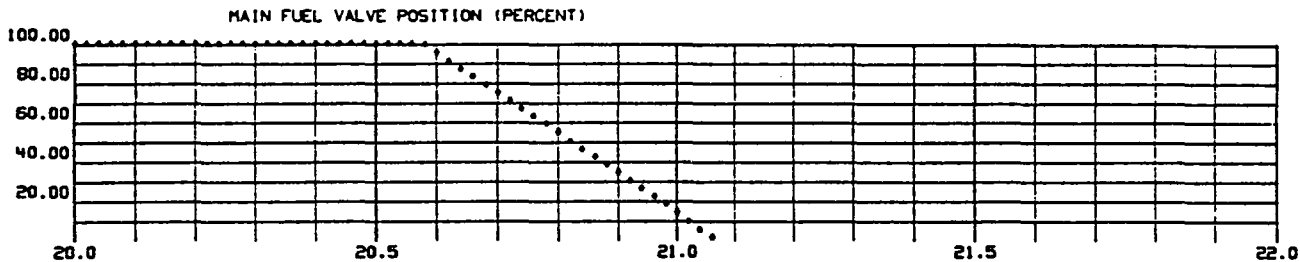
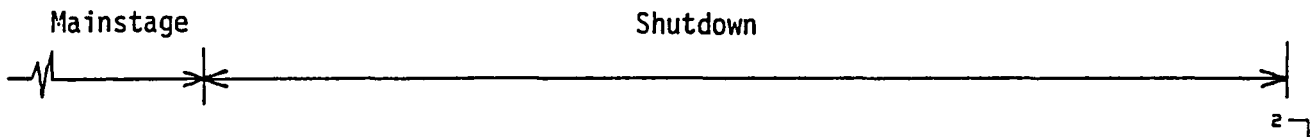

Figure 6-6 Valve Sequences - 7.5K Engine Shutdown

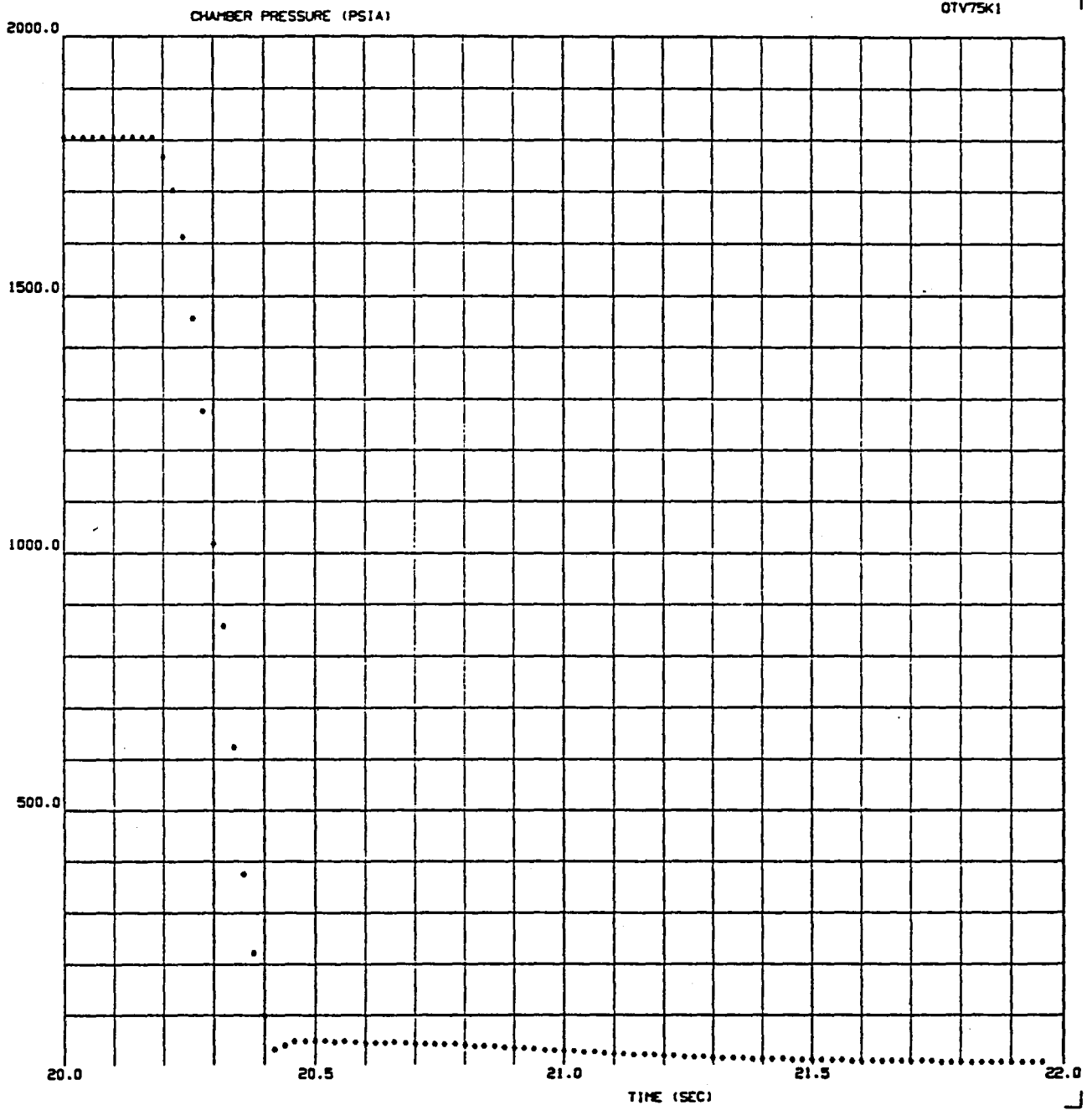

Figure 6-7 Chamber Pressure - 7.5K Engine Start

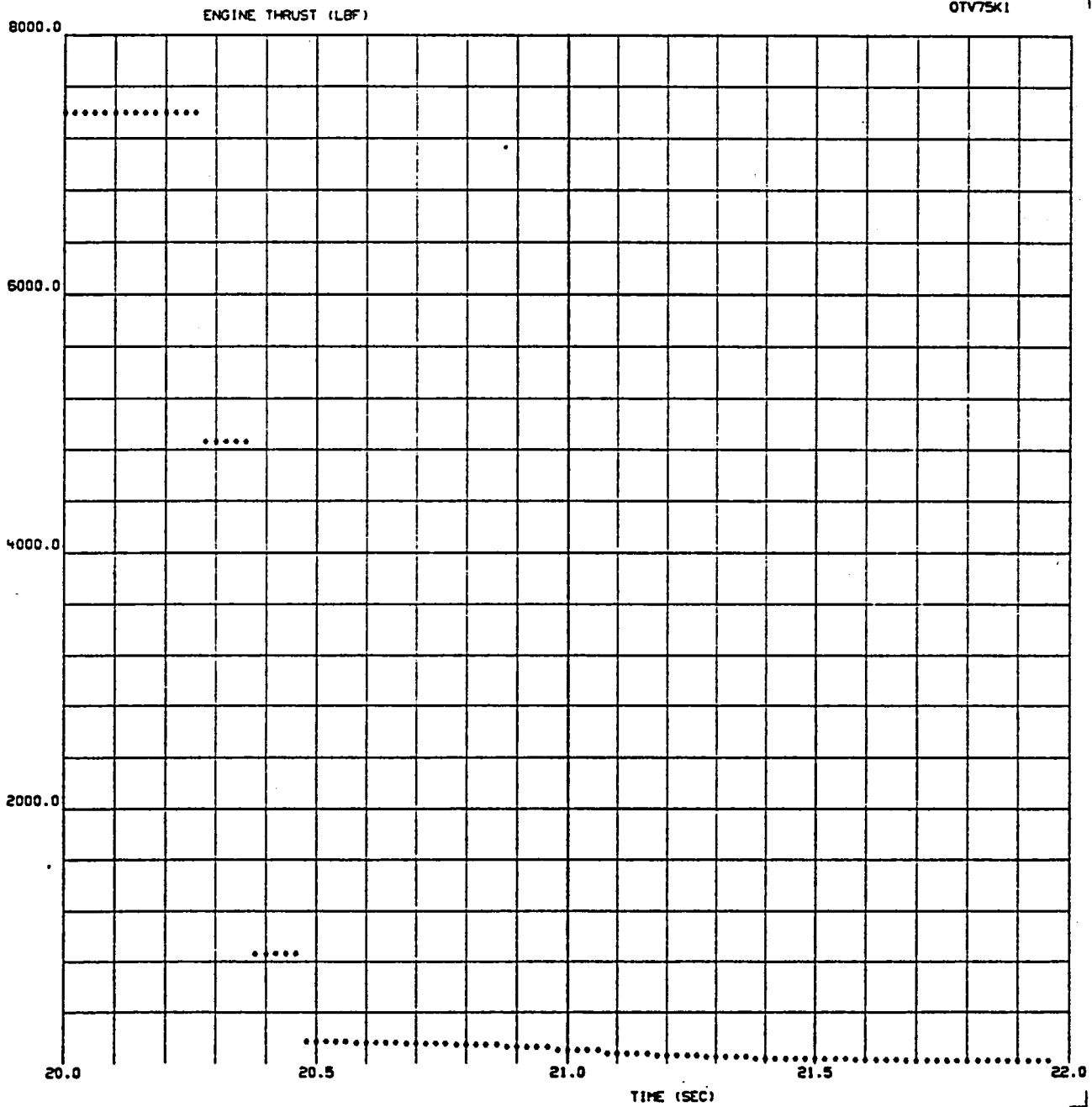

Figure 6-8 Engine Thrust - 7.5K Engine Shutdown

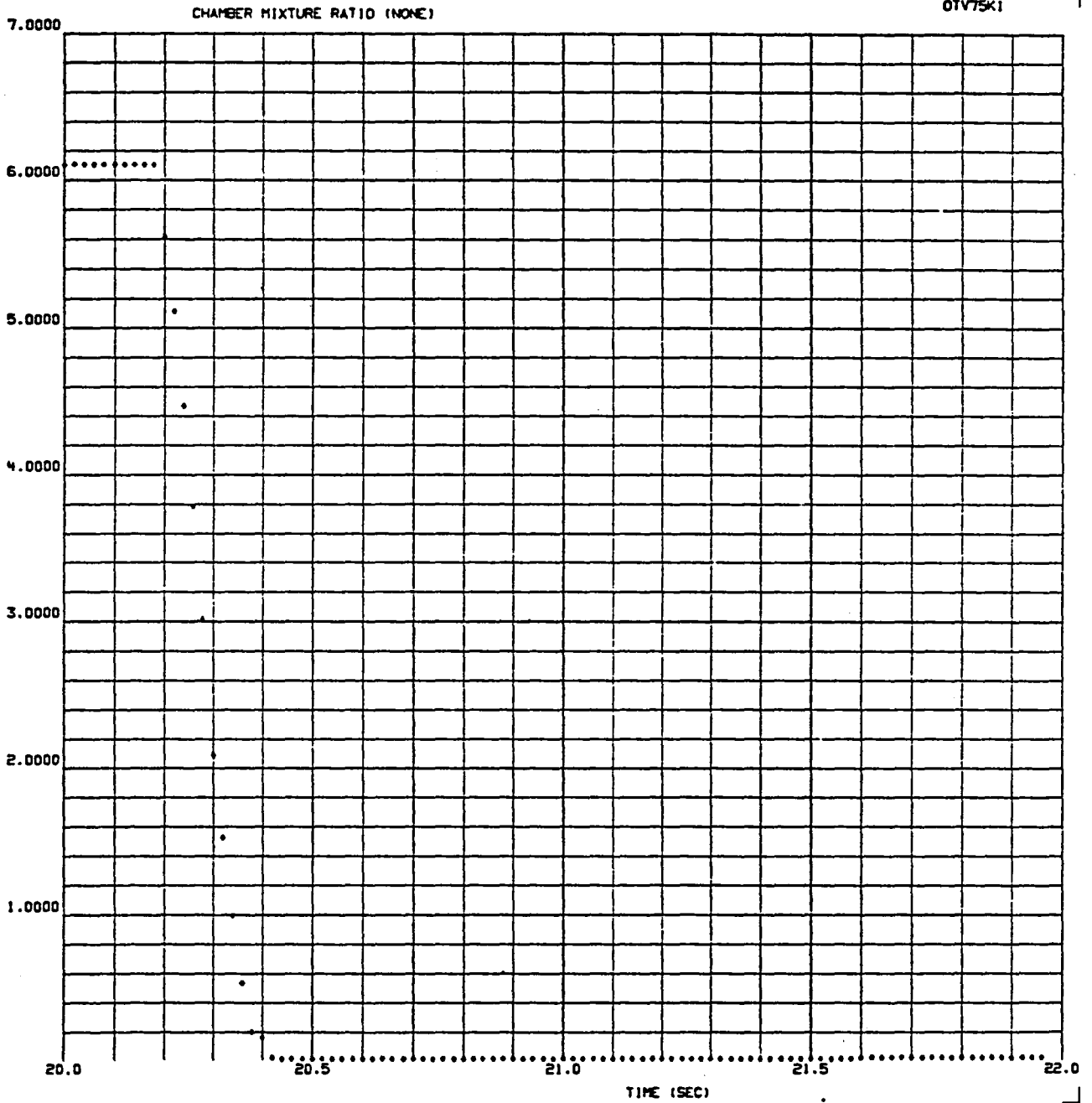

Figure 6-9 Chamber Mixture Ratio - 7.5K Engine Shutdown

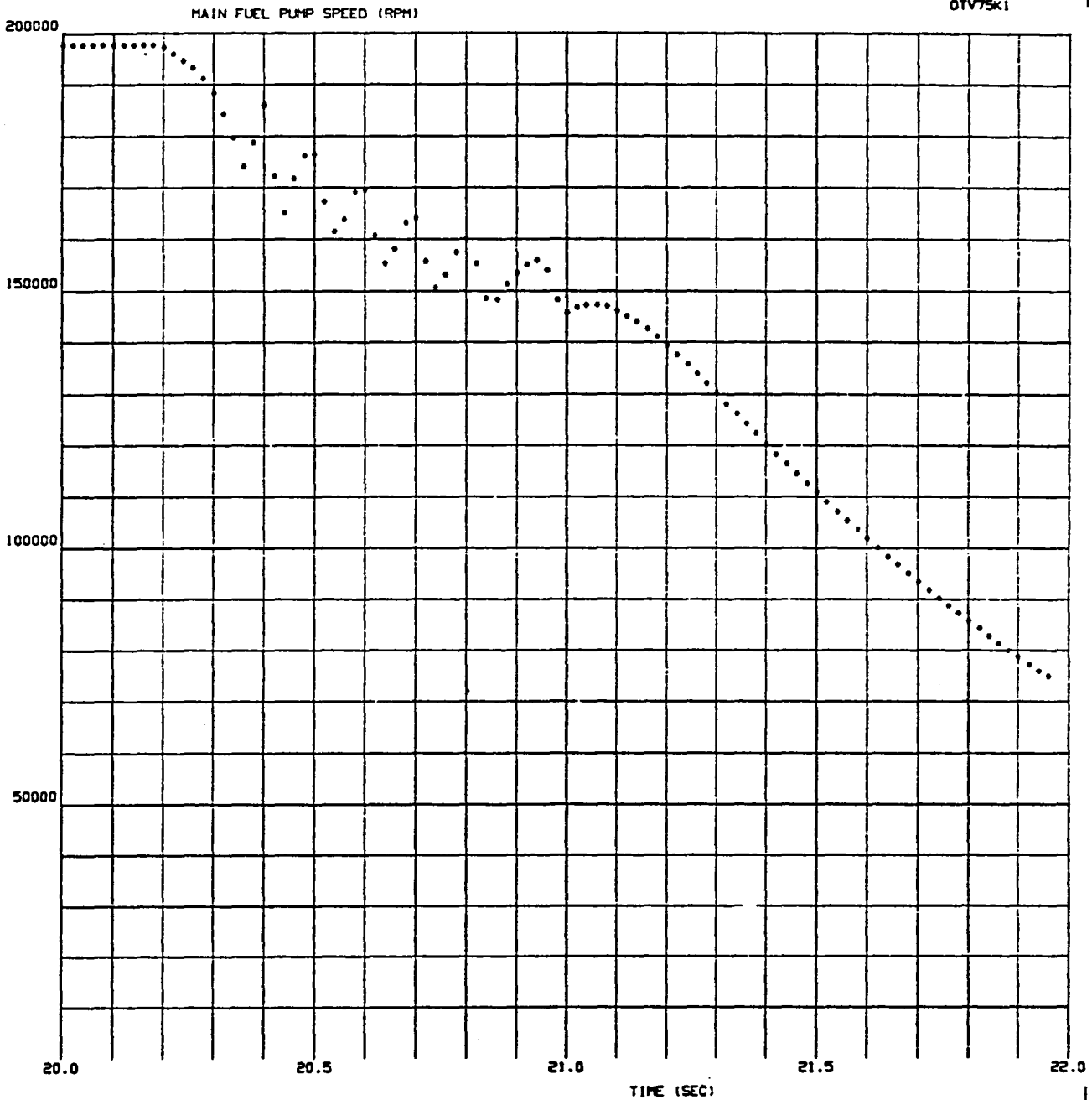

Figure 6-10 Main Fuel Pump Speed - 7.5K Engine Shutdown

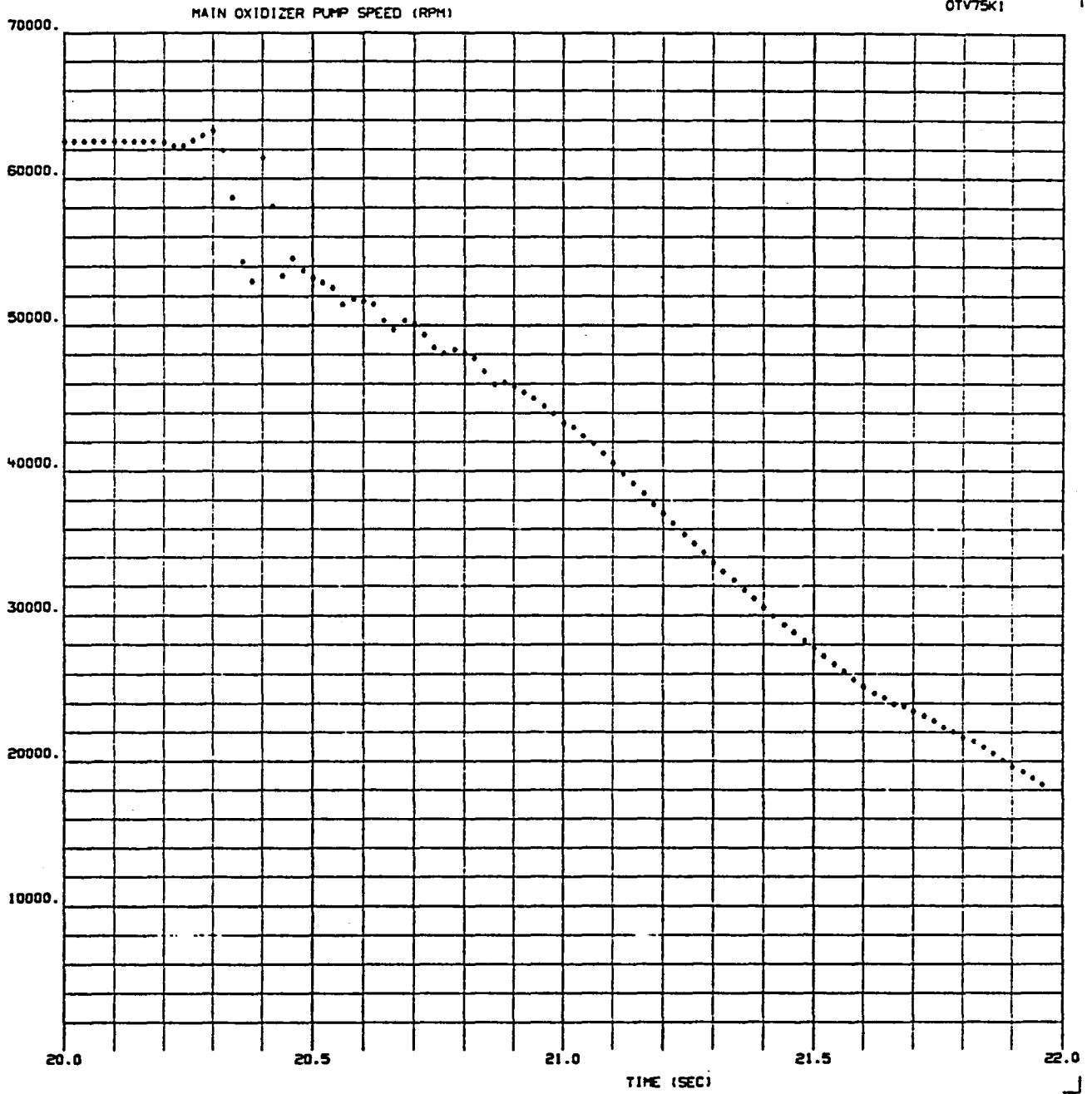

Figure 6-11 Main Oxidizer Pump Speed - 7.5K Engine Shutdown



APPENDIX 7
 TRANSIENT ENGINE SIMULATION WITH TSV

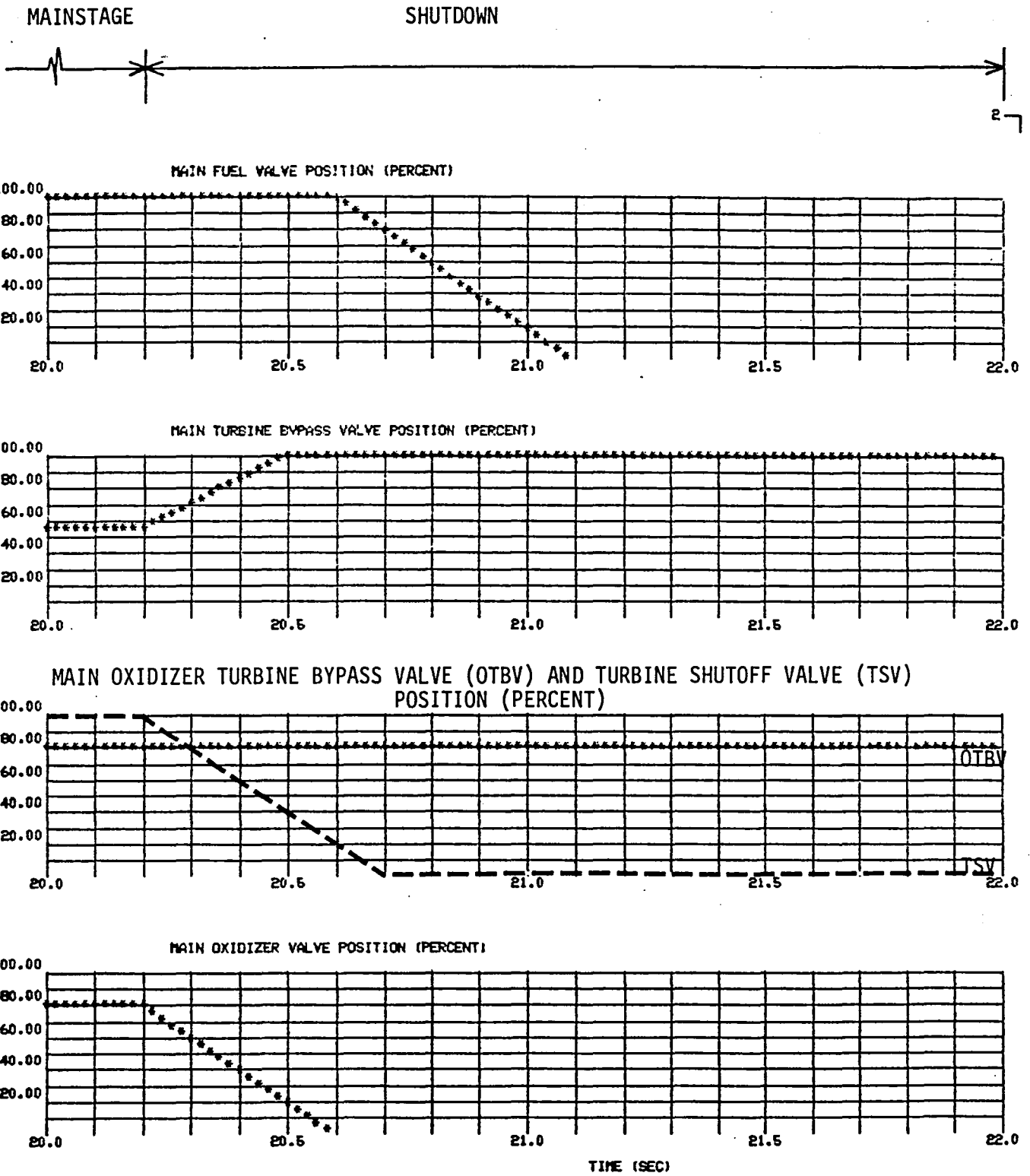

Figure 7-1 Valve Sequences - 7.5K Engine Shutdown with TSV Located
 Demonstration of HPOT

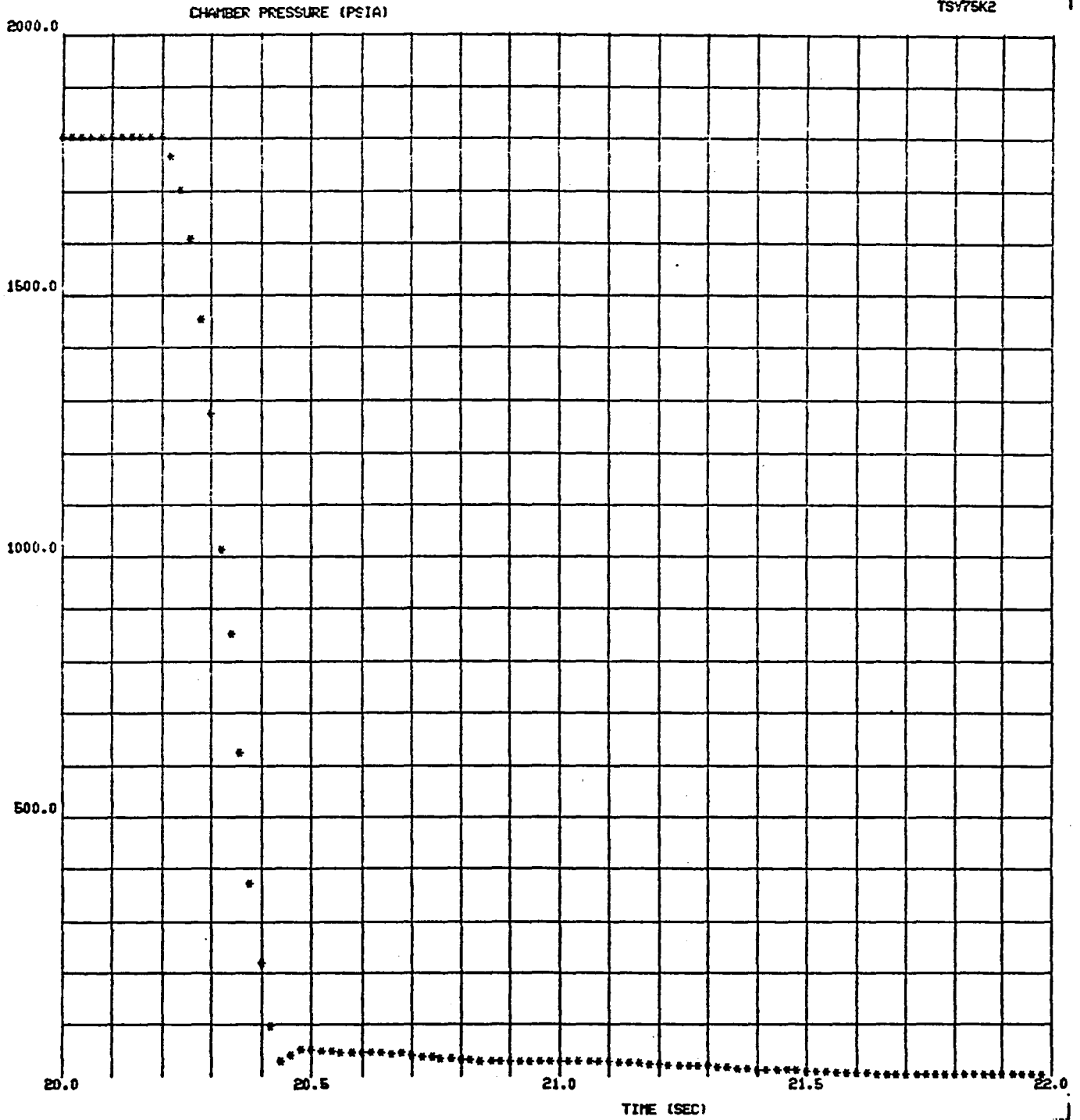

Figure 7-2 Chamber Pressure - 7.5K Engine Shutdown with TSV Located Downstream of HPOT

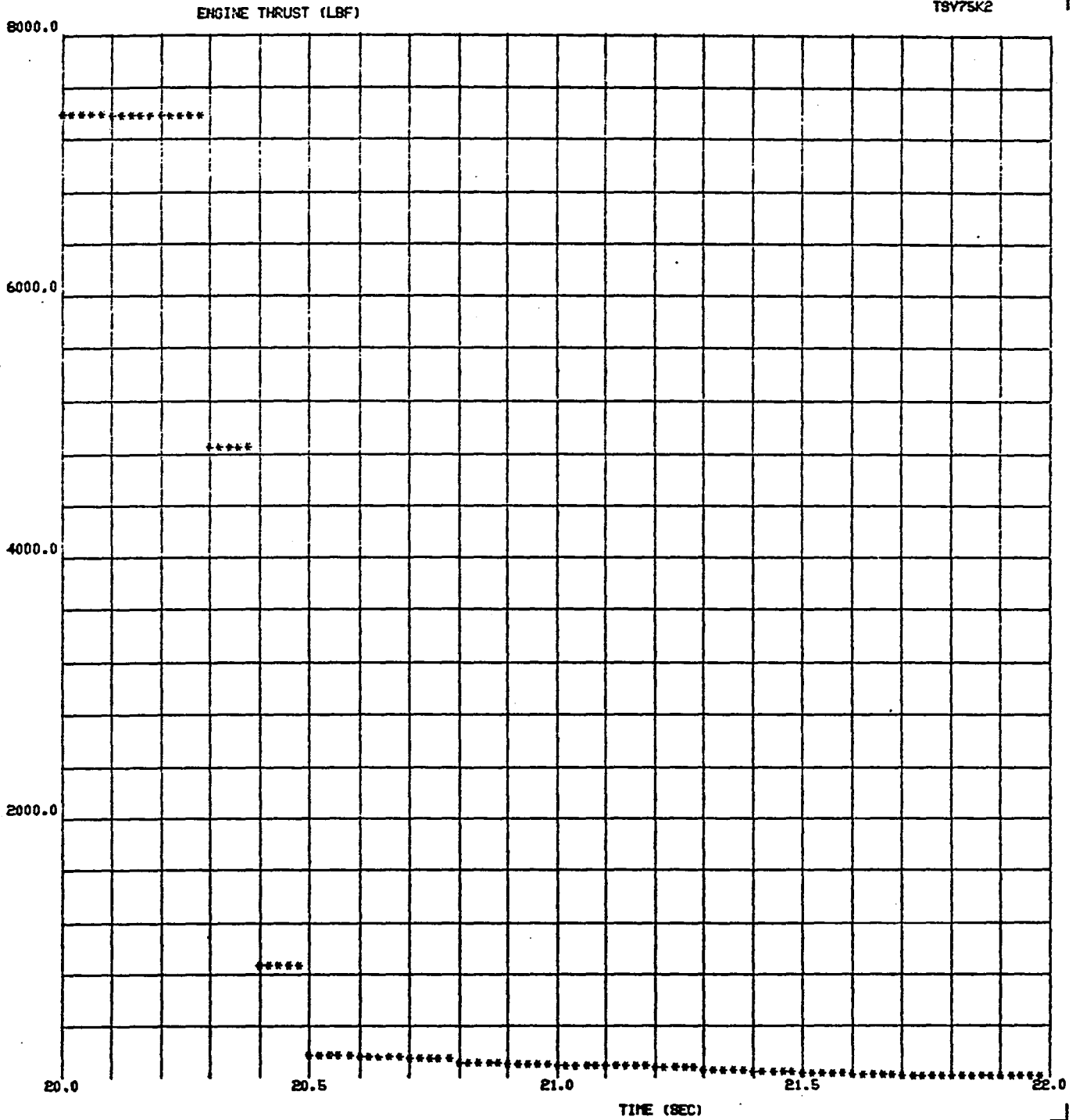

Figure 7-3 Engine Thrust - 7.5K Engine Shutdown with TSV Located Downstream of HPOT

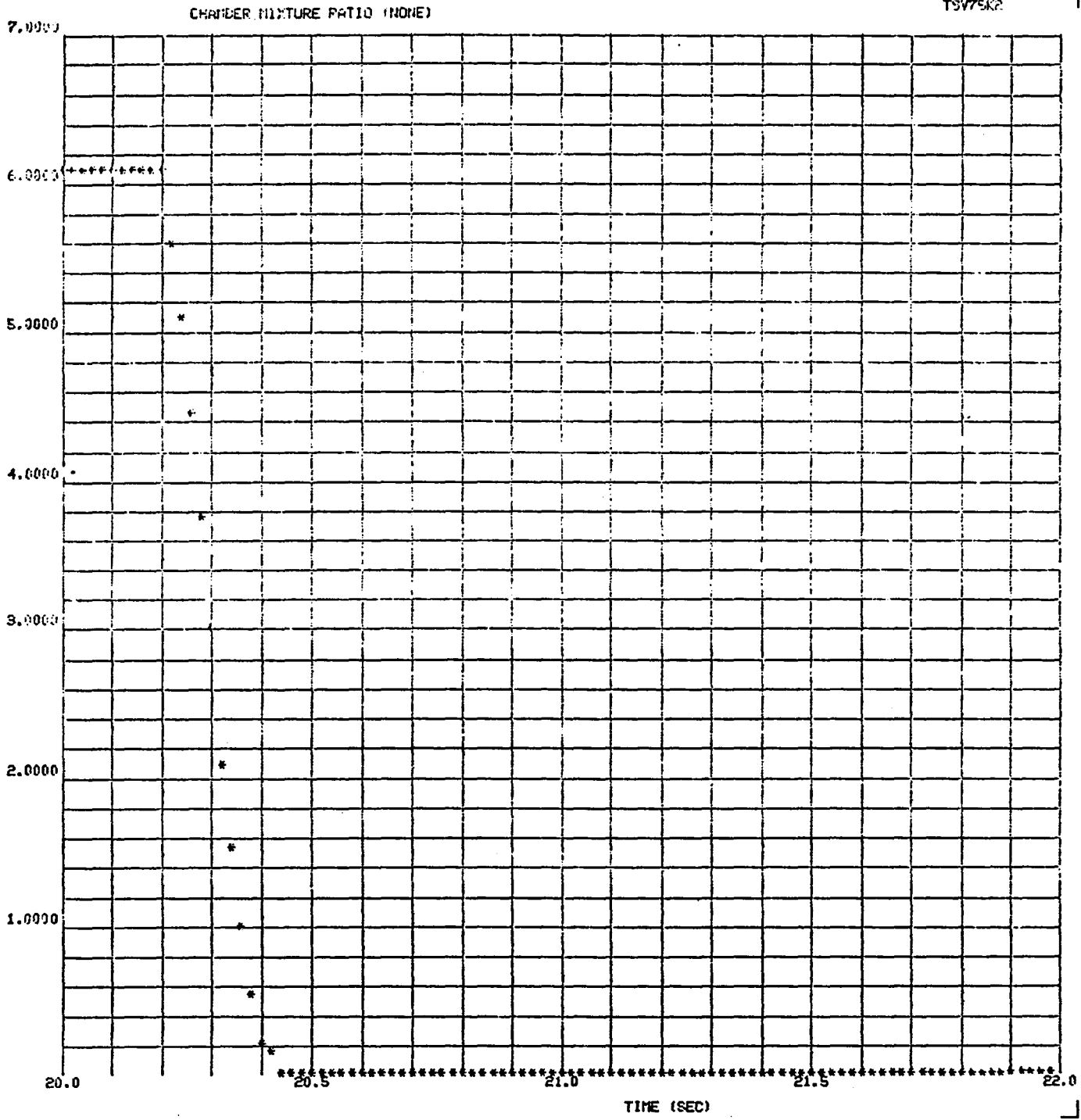

Figure 7-4 Chamber Mixture Ratio - 7.5K Engine Shutdown with TSV Located Downstream of HPOT

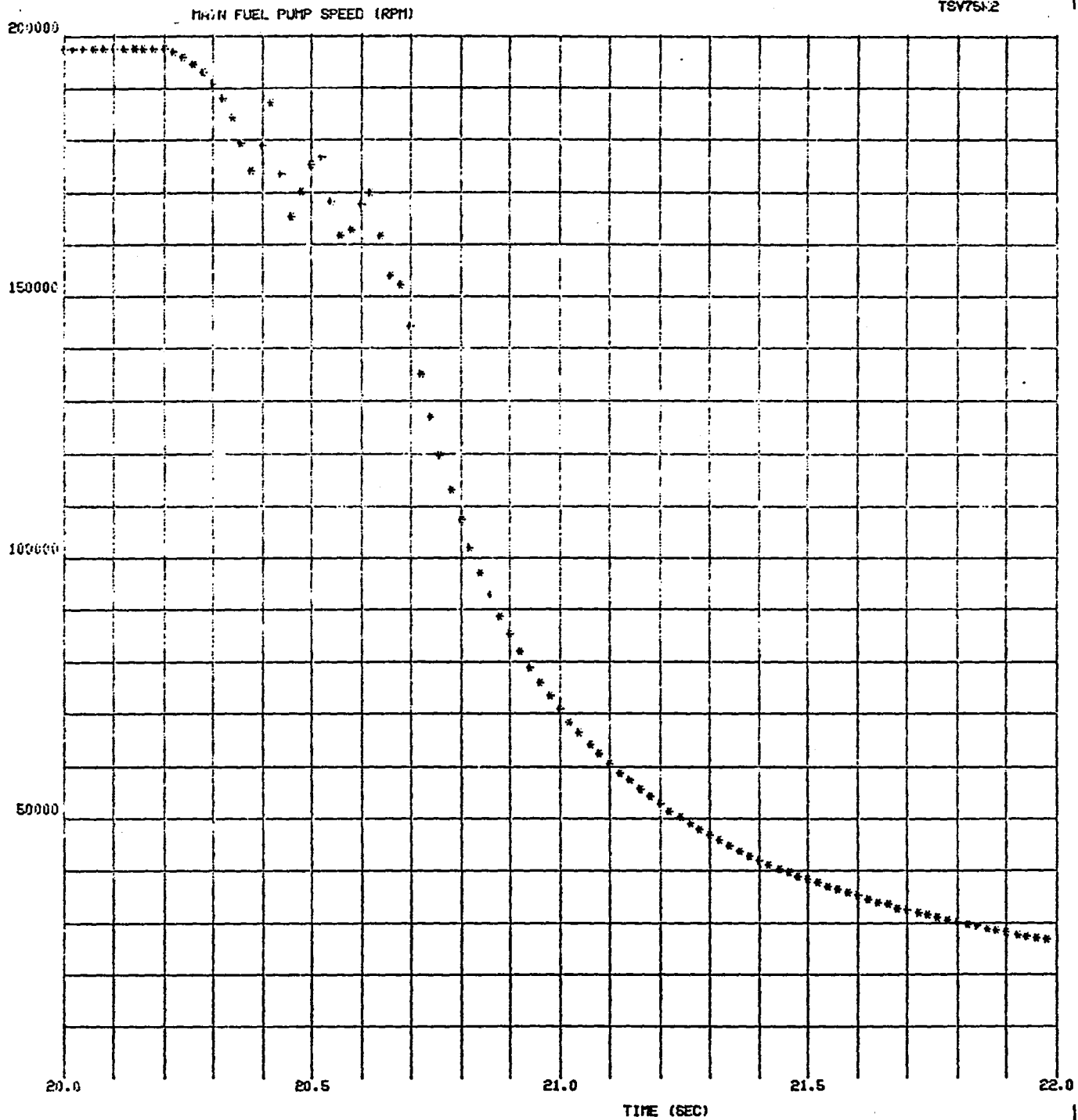

Figure 7-5 Main Fuel Pump Speed - 7.5K Engine Shutdown with TSV Located Downstream of HPOT

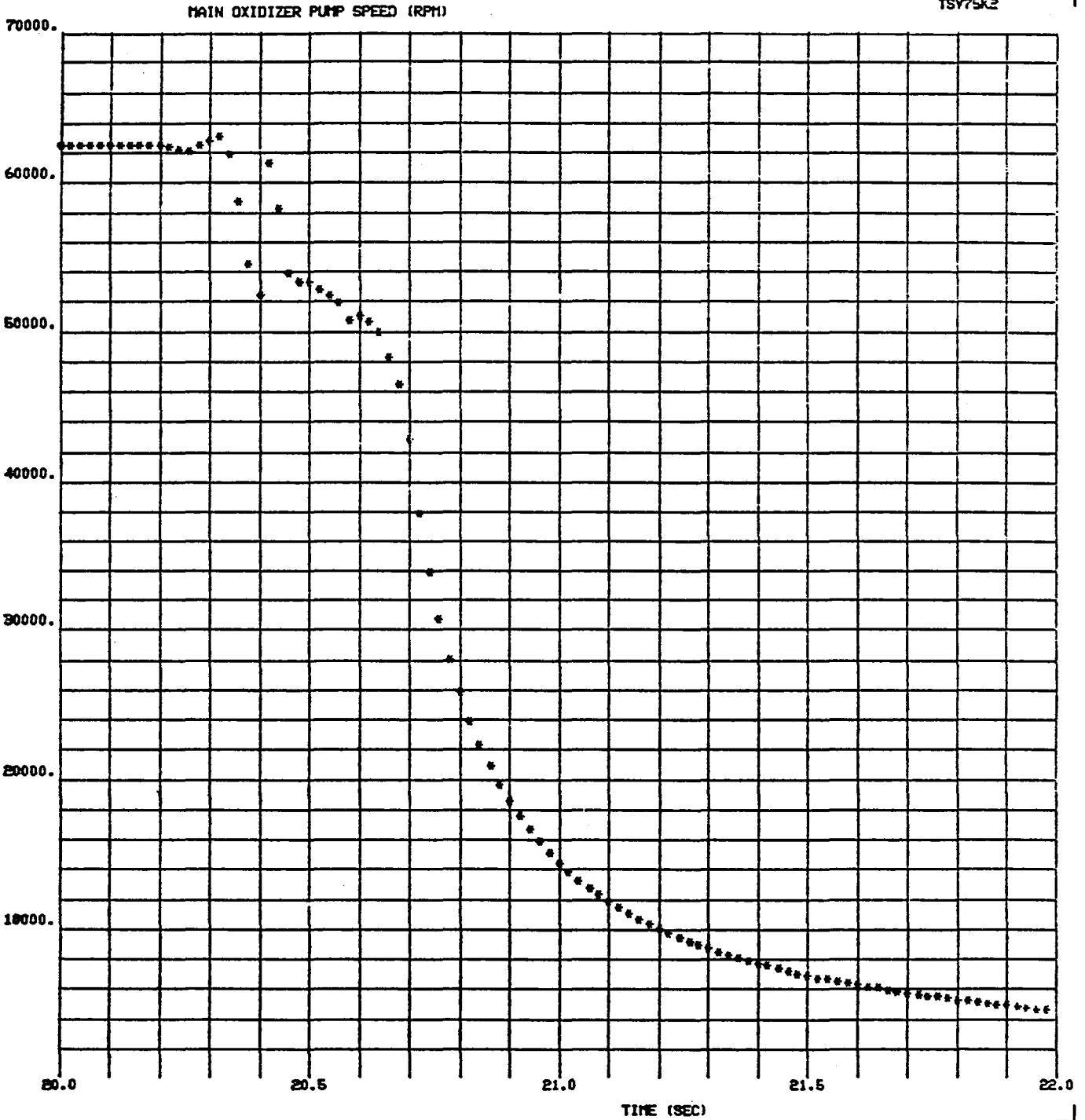

Figure 7-6 Main Oxidizer Pump Speed - 7.5 K Engine Shutdown with TSV Located Downstream of HPOT

MAINSTAGE

SHUTDOWN

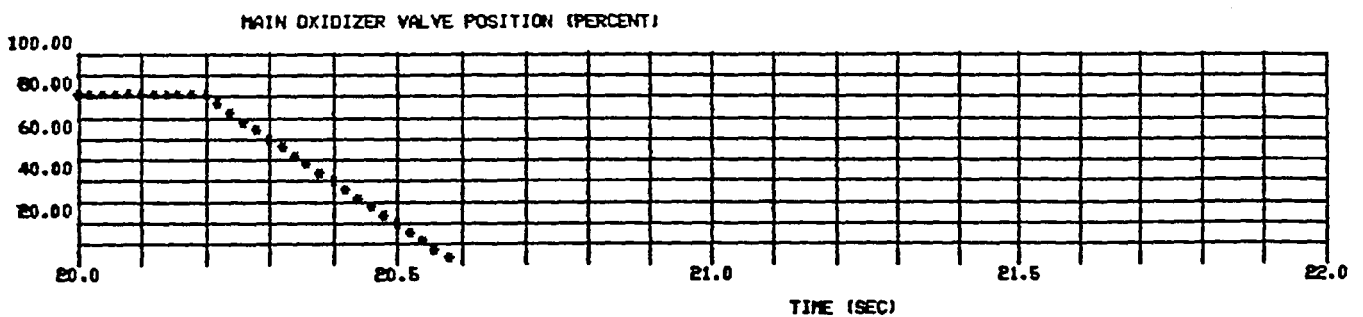
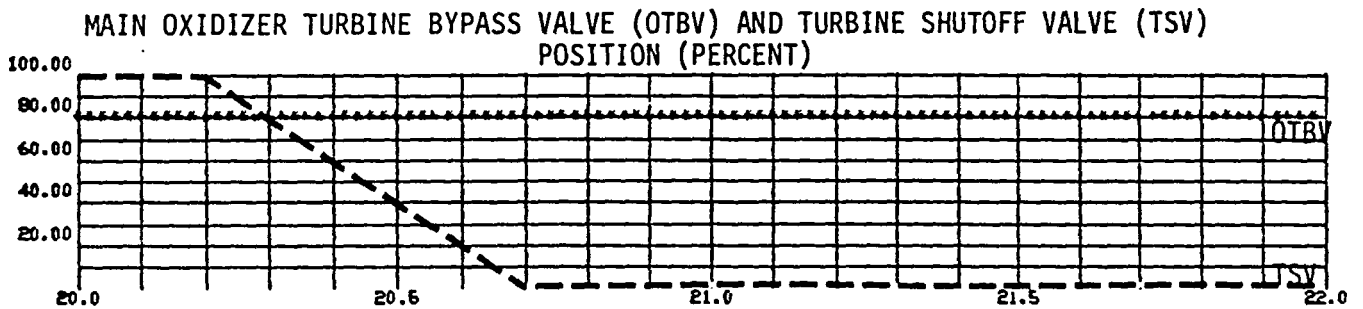
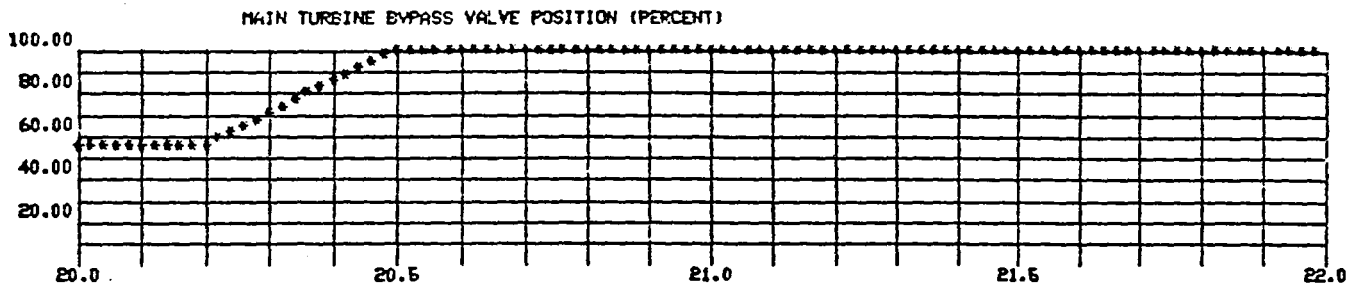
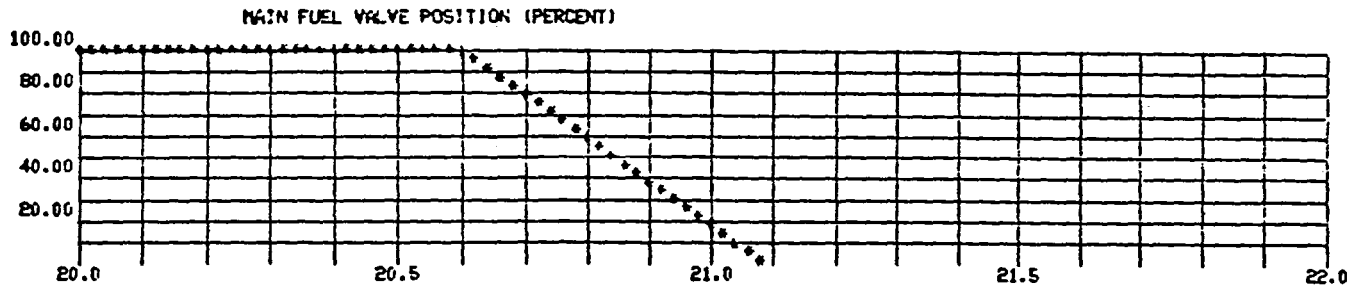
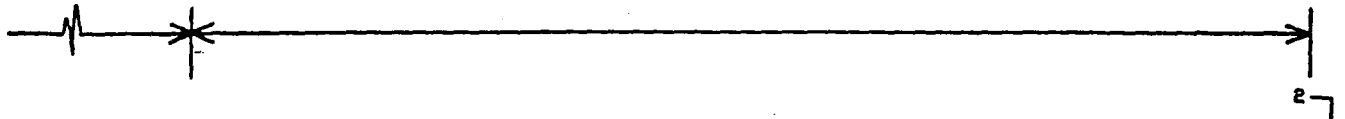

Figure 7-7 Valve Sequences - 7.5K Engine Shutdown with TSV Located Upstream of HPFT

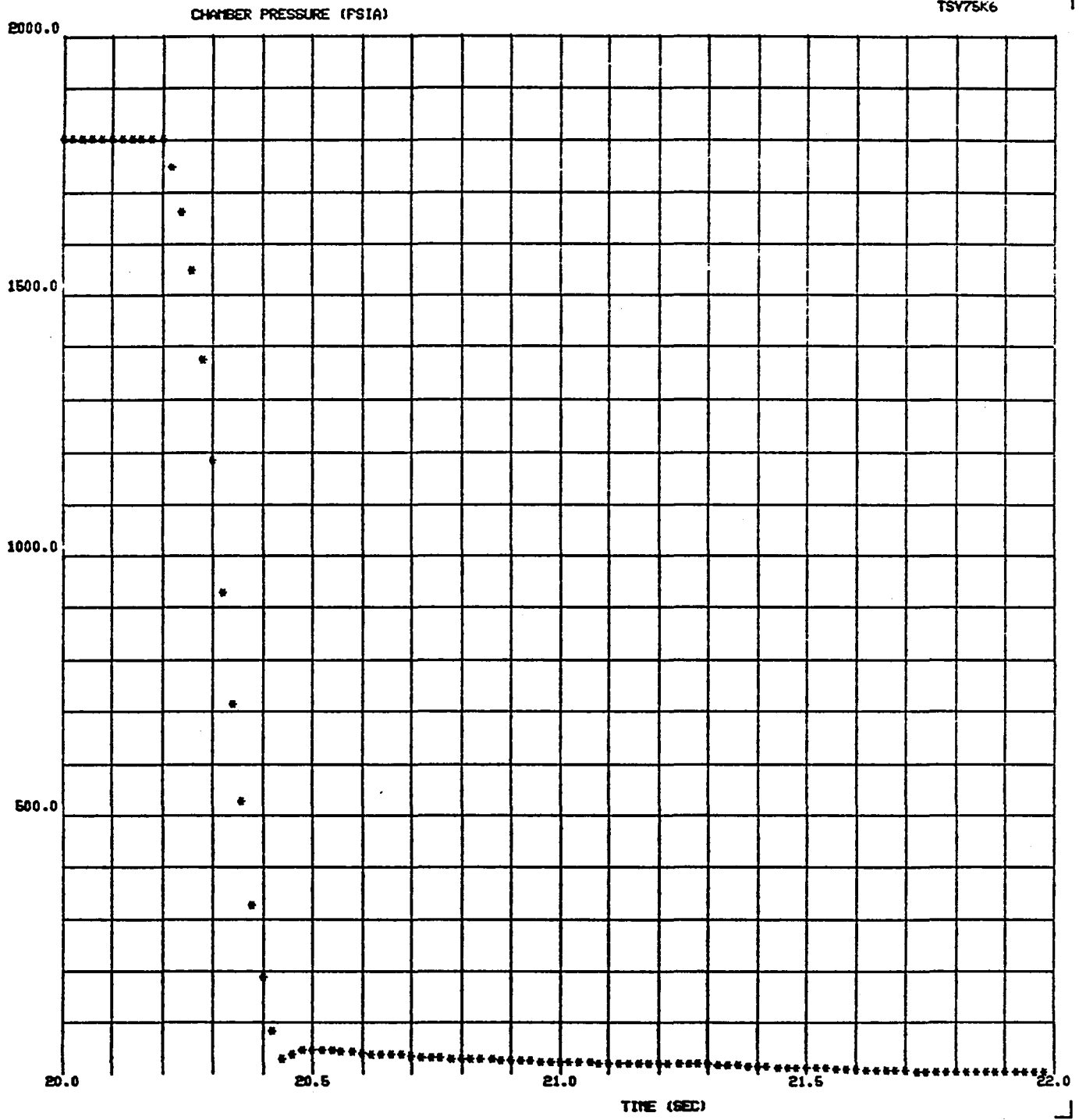

Figure 7-8 Chamber Pressure - 7.5K Engine Shutdown with TSV Located Upstream of HPFT

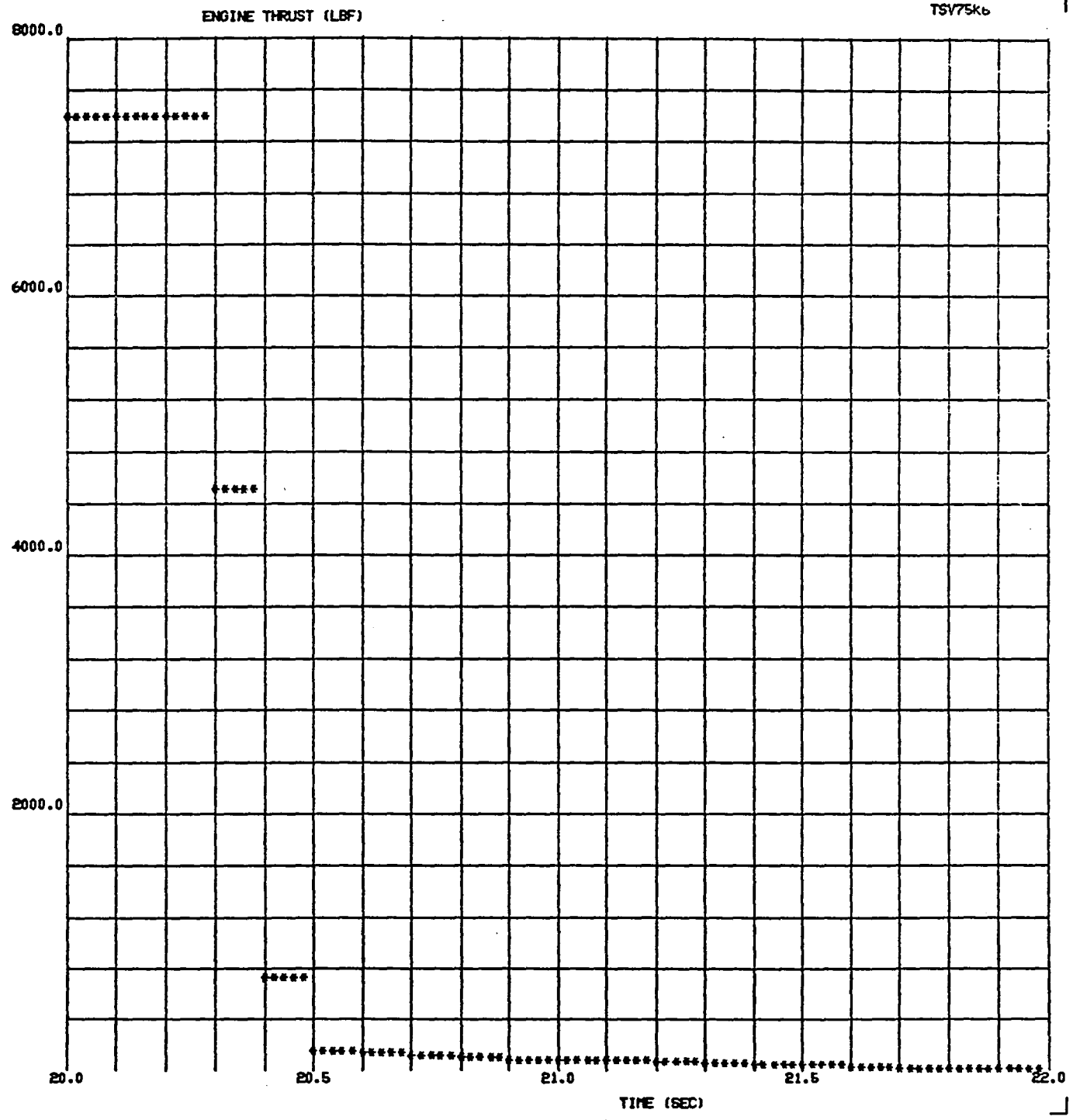

Figure 7-9 Engine Thrust - 7.5K Engine Shutdown with TSV Located Upstream of HPFT

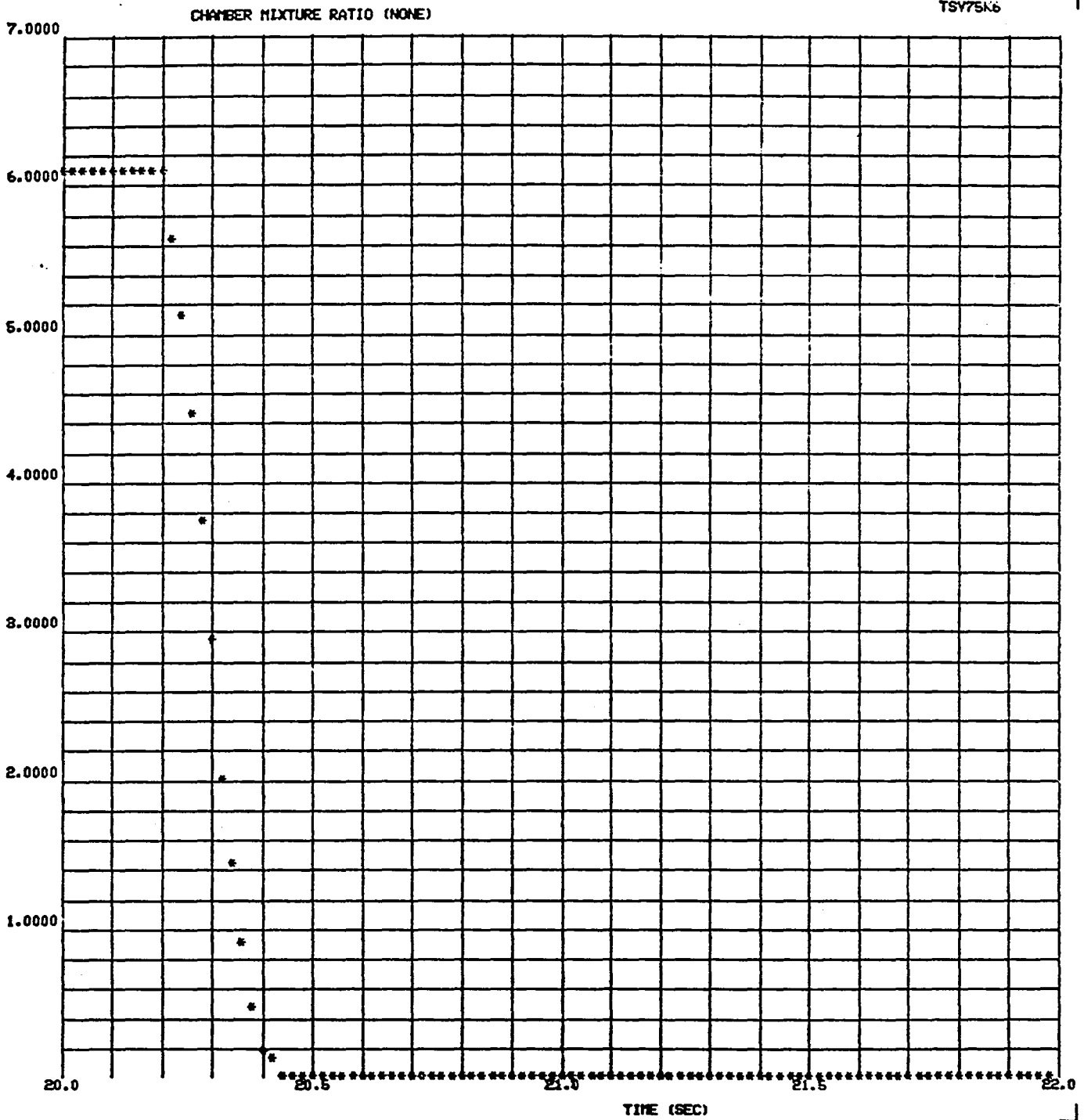

Figure 7-10 Chamber Mixture Ratio - 7.5K Engine Shutdown
with TSV Located Upstream of HPFT

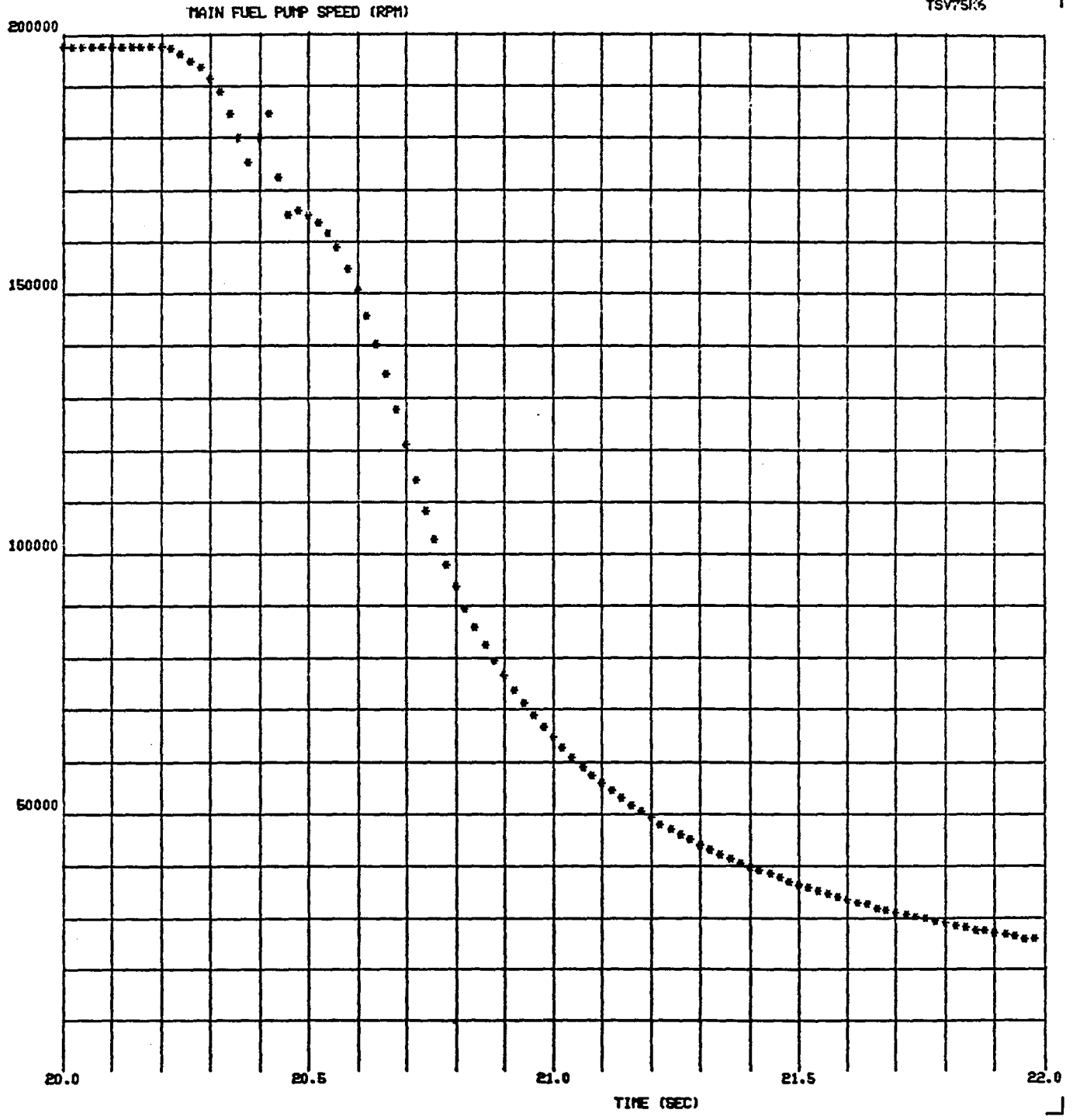

Figure 7-11 Main Fuel Pump Speed - 7.5K Engine Shutdown with TSV Located Upstream of HPFT

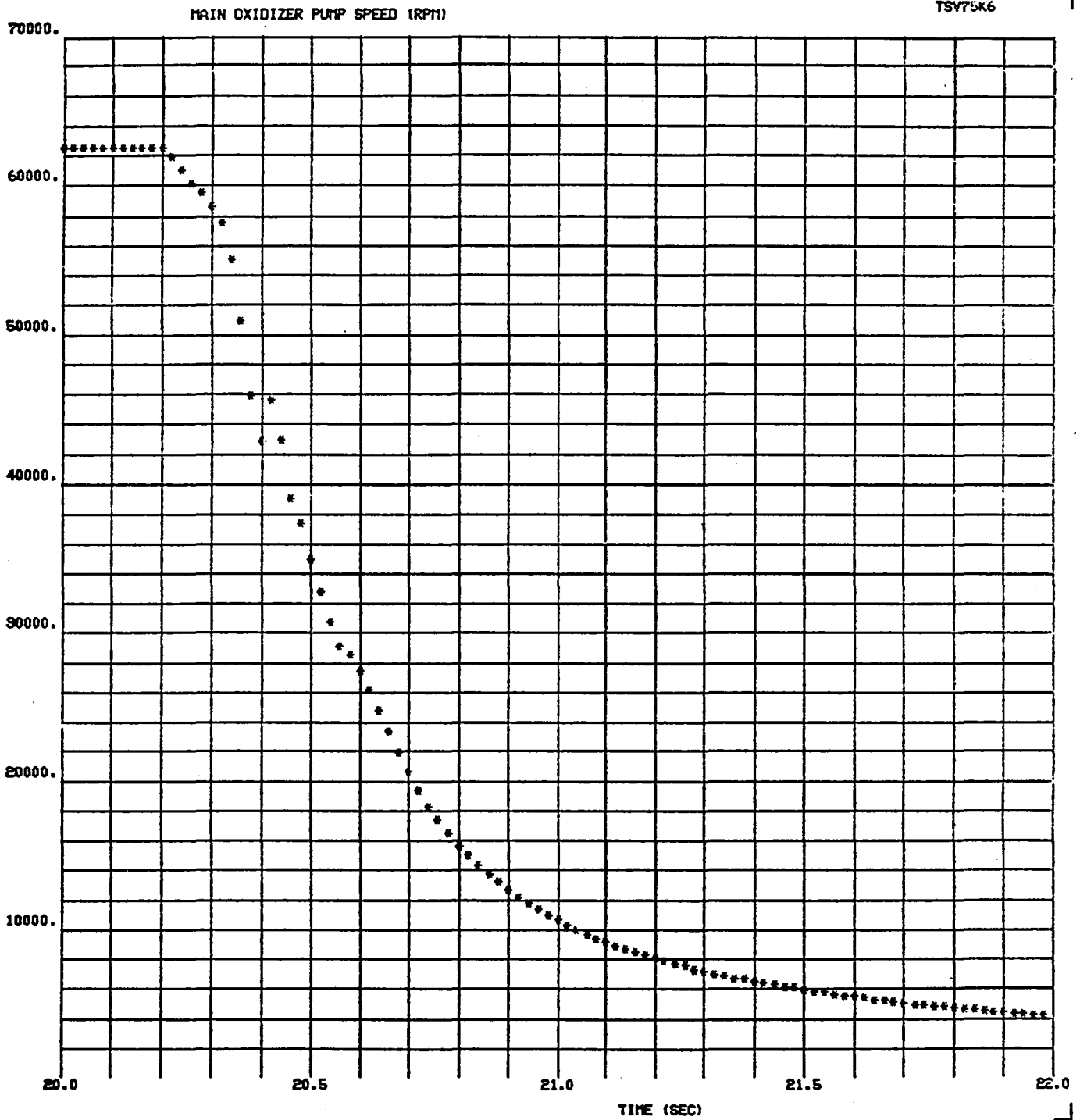

Figure 7-12 Main Oxidizer Pump Speed - 7.5K Engine Shutdown
with TSV Located Upstream of HPFT

End of Document