

**NASA
Reference
Publication
1156**

1986

Introduction to the Theory of Atmospheric Radiative Transfer

James J. Buglia
*Langley Research Center
Hampton, Virginia*

NASA

National Aeronautics
and Space Administration

**Scientific and Technical
Information Branch**

Contents

Introduction	1
Chapter 1	5
Introductory Concepts	5
Definitions	8
Absorption of Radiation	13
Scattering of Radiation	14
Chapter 2	23
The Equation of Transfer	23
The RTE in Plane-Parallel Atmospheres	27
Further Specialized Forms	29
Expansion of the RTE into Legendre Polynomials	30
RTE for Diffuse Component Only	34
Chapter 3	39
Formal Solutions to the Intensity and Flux Equations	39
Chapter 4	49
Reflection and Transmission Coefficients, Surface Effects, and Albedo	49
Inclusion of Surface Effects	54
Chapter 5	59
Approximate Analytical Solutions to the RTE	59
Thin-Atmosphere Approximation	60
Single-Scatter Solution	67
Two-Stream Solutions	76
Schuster-Schwartzschild	77
Sagan-Pollack	79
Coakley-Chylek	81

PAGE 11 INTENTIONALLY BLANK
PRECEDING PAGE BLANK NOT FILMED

Solution of the Two-Stream Equations	81
Solution for Conservative Scattering, $\tilde{\omega} = 1$	84
Solution for Diffuse Component Only	86
Chapter 6	91
The Eddington Solution	91
Two-Stream and Eddington Solutions for Semi-Infinite Atmospheres	96
The Delta-Eddington Method	96
Comparison of Two-Stream and Eddington Results	99
Chapter 7	105
Discrete Ordinates Method	105
Gaussian Integration	106
RTE for Conservative, Isotropic Scattering	107
Some Elementary Identities	113
The Flux Equation	115
The Source Function	117
The Law of Darkening	118
The H -Functions	120
Diffuse Radiation With Non-Conservative, Isotropic Scattering	124
Similarity Relations	132
Chapter 8	137
The Principle of Invariance	137
First-Order Solution for the H -Function	149
Chapter 9	157
Additional Topics	157
Determination of Optical Parameters	157
Finite Homogeneous Atmospheres	159
Anisotropic Scattering	159
Effect of Surface Albedo	160
Other Computational Techniques	160
Adding and Doubling Methods	160
The Spherical Harmonics Method	163
Monte Carlo Method	164

Non-Homogeneous Atmospheres	165
Other Problems	166
References	167

Acknowledgments

The author is deeply indebted to Pat McCormick, Head of the Aerosol Research Branch, Atmospheric Sciences Division, NASA Langley Research Center, for permitting him the time to compile and organize these notes. A number of conversations with him have indicated that this could prove to have been a useful undertaking, and that a significant number of people could benefit from this effort.

The author also acknowledges a great debt to a number of friends who so generously reviewed the text and made many suggestions and improvements. For all its present shortcomings, it has been much improved through their efforts. In particular, the author would like to thank Jacqueline Lenoble of the Université des Sciences et Techniques de Lille, France, as well as G. Louis Smith and T. Dale Bess of NASA Langley Research Center, and R. Earl Thompson of the Systems and Applied Science Corporation, Hampton, Virginia, for their generous contributions of time and effort, and for their many discussions.

1
2
3
4
5
6
7
8
9
10
11
12
13
14
15
16
17
18
19
20
21
22
23
24
25
26
27
28
29
30
31
32
33
34
35
36
37
38
39
40
41
42
43
44
45
46
47
48
49
50
51
52
53
54
55
56
57
58
59
60
61
62
63
64
65
66
67
68
69
70
71
72
73
74
75
76
77
78
79
80
81
82
83
84
85
86
87
88
89
90
91
92
93
94
95
96
97
98
99
100



Introduction

The study of the absorption, emission, and scattering of electromagnetic radiation as it passes through a medium with which it interacts is a fascinating subject involving the close interconnection of many disciplines in mathematics and physics. This subject originated in the study of the properties and fate of radiant energy as it traverses stellar interiors, and much of the terminology and many of the definitions reflect the impetus given by the early researchers in the field. More recently, a great body of this theory has been applied to the study of the passage of solar and terrestrial radiation through the Earth's atmosphere, as well as to the study of radiation in the atmospheres of the other planets. In particular, studies of climate and climate models, and the detection and measurement of the distribution of water vapor, trace gases, and aerosols in the atmosphere have given additional importance to this topic, and literally hundreds of technical papers have been written in the past 20 or so years in which applications of radiative transfer (RT) theory have been made to these and other topics in atmospheric physics.

The lack of standardization of symbols and terms in current radiative transfer literature has caused some difficulty, especially for the neophyte researcher, in comparing analyses and numerical results among the published texts and papers in radiative transfer theory; this consequently presents the new researcher with some difficulties in developing an integrated picture of, or feel for, this most fascinating subject. The present monograph is an attempt to alleviate this frustrating circumstance by developing some of the fundamental concepts in RT theory, and by defining some of the more useful approximate solutions to the radiative transfer equation (RTE) using as consistent a set of definitions and symbols as is practical. This will hopefully make the newcomer's transition to the more formal technical literature somewhat less painful.

The radiative transfer equation appears in many forms in the literature, depending on the discipline, the area of application, and the whims of the writer. The various forms derived herein are those most generally encountered in atmospheric applications. As in any scientific discipline, the technical literature is generally written *by experts for*

experts, and, as a consequence of long familiarity with the basic theory, a great deal is generally omitted from their papers as being well known or implied, causing still more confusion to the researcher new to the field. Frequently, for example, one paper presents specialized forms of the RTE which supposedly represent the same physical situation as in another paper, and yet the physical forms of the corresponding equations are dissimilar. The present book will hopefully aid the reader in recognizing these differences and the reasons for them, and thus allow the reader to construct a mental link between the seemingly different results.

Some of the classical solutions to the various forms of the RTE will be derived in detail. These will include the thin-atmosphere approximation, the single-scattering solution, various forms of the two-stream solutions, the Eddington solution, and the discrete ordinates method of Chandrasekhar. In some cases, numerical examples will be given so that the reader can develop a feel for the order of magnitude of the numbers involved. Appropriate caveats will be rendered concerning regions of applicability of the approximation methods.

A working group of the Radiation Commission of the International Association of Meteorology and Atmospheric Physics (IAMAP) headed by Jacqueline Lenoble of the University of Lille, France, has edited an extremely comprehensive but very compact two-volume set of notes containing descriptions of all the presently used methods for computing the radiative transfer through scattering atmospheres. Because of its scope, this document is difficult to use as a tutorial guide, but is an excellent reference source for the experienced researcher. Its title is "Standard Procedures to Compute Atmospheric Radiative Transfer in a Scattering Atmosphere"; it is published by the IAMAP, and is obtainable from NCAR, Boulder, Colorado. This document discusses all the current problems in radiative theory, all the methods currently in fashion, and gives hundreds of references. It is highly recommended for source material once the fundamentals of the present text are fully grasped. Prof. Lenoble has edited and revised a set of these documents, which is available as *Radiative Transfer in Scattering and Absorbing Atmospheres: Standard Computational Procedures*, A. Deepak Publishing, Hampton, Virginia, 1985 (ISBN 0-937194-05-0).

The present book is not intended to be a textbook on radiative transfer theory, nor is it intended to be authoritative or complete—the author has neither the inclination nor the expertise to attempt such a monumental task. It is meant rather to be a set of notes, mathematically more detailed than one usually finds in a textbook or formal paper, presenting the derivations and solutions to various forms of the integro-differential equation which describes the transfer of

radiant energy through an absorbing, scattering, and emitting medium. The basic thrust of these notes is twofold: first, to provide the reader with a firm physical foundation of the basics of radiative transfer which will permit a ready transition to the more formal literature from which this foundation can be expanded; second, to present some of the more elementary, but perhaps more useful, solutions to the RTE in sufficient detail for the reader to be able to concentrate on the physical principles involved in these developments rather than being bogged down by a lot of superfluous mathematical detail, thereby helping the reader develop a physical feel for the way the various components interact and for their relative importance.

To give proper credit where it is due, it should be mentioned that except for the specific papers referenced in the body of the text, most of the material for this monograph was extracted from three texts: those of Chandrasekhar (1960), Liou (1980), and Özisik (1973)—in particular, chapters 1–5 of Chandrasekhar, chapters 1 and 6 of Liou, and chapters 1, 8, and 9 of Özisik.

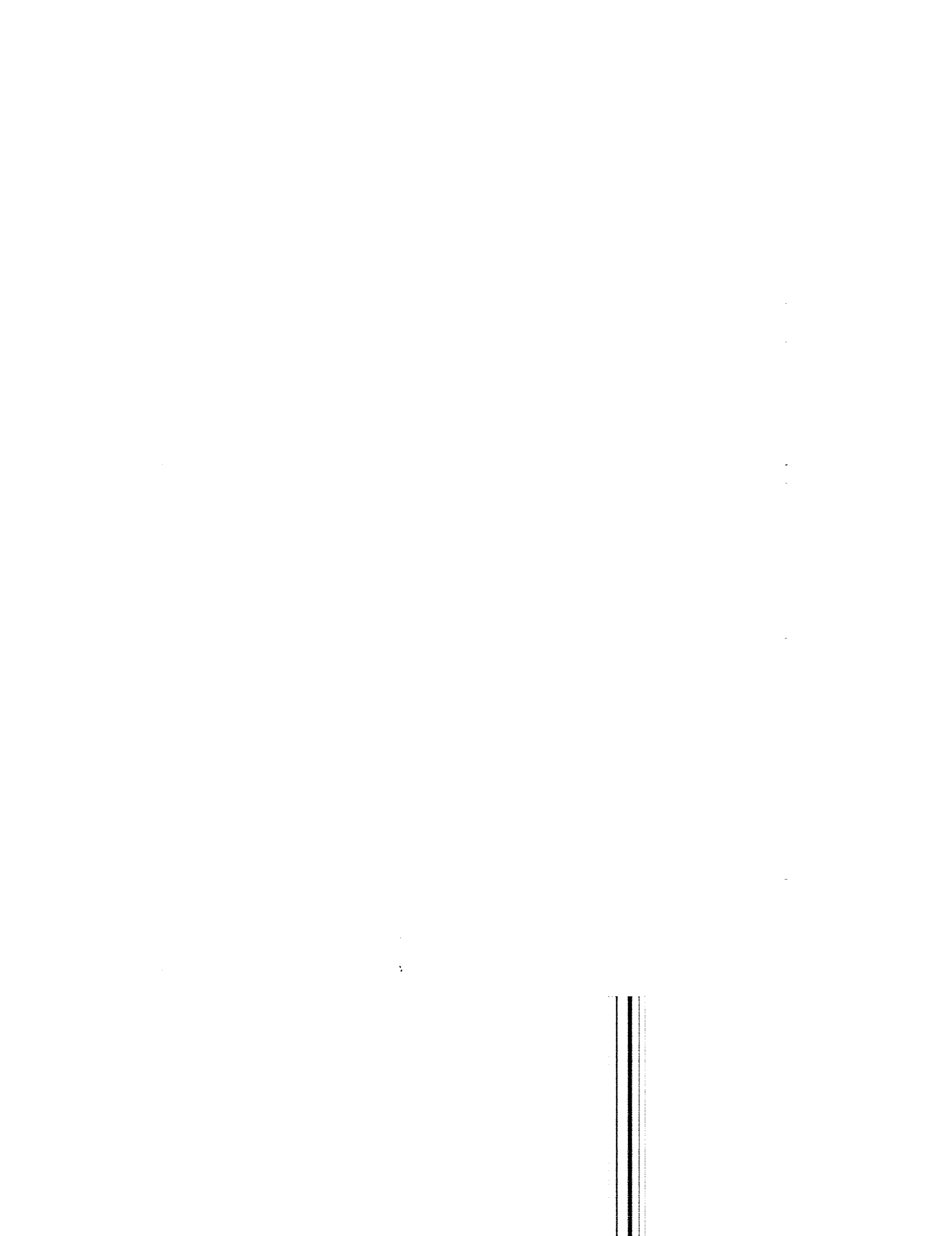

Chapter 1

Introductory Concepts

All substances continuously emit electromagnetic radiation as a result of the thermal motions of the molecules and atoms of which they are made. The thermal agitation of these particles increases with temperature, and consequently, the emitted radiation frequencies increase with temperature. The wavelengths of these radiations range from several kilometers for very long wavelength radio transmissions down to 10^{-12} cm and less for cosmic rays and beyond. A very rough and somewhat arbitrary division of the electromagnetic spectrum is given below in table 1-1.

TABLE 1-1. THE ELECTROMAGNETIC SPECTRUM

Wavelength	Type of radiation
10^{-1} to 10^{10} cm	Radio, radar, TV, etc.
10^{-4} to 10^{-1} cm	Infrared
10^{-5} to 10^{-4} cm	Visible
10^{-6} to 10^{-5} cm	Ultraviolet
10^{-9} to 10^{-6} cm	X-rays
10^{-12} to 10^{-9} cm	Gamma rays
? to 10^{-12} cm	Cosmic rays

The term *thermal radiation* is normally reserved for radiation that can be detected as either heat or light, and so is generally applied to that region of the spectrum ranging from about 10^{-5} to 10^{-1} cm; i.e., the visible and infrared portions of the spectrum. Since we shall be primarily concerned with the infrared portion of the spectrum, a unit called the *micron*, equal to 10^{-4} cm (or 10^{-6} m) will be used throughout these notes. In these terms, the thermal radiation regime extends from about 0.1 to 1000 microns.

PRECEDING PAGE BLANK NOT FILMED

5

PAGE 4 INTENTIONALLY BLANK

Now, in addition to emitting their own radiation, most atmospheric constituents, from molecules to water vapor droplets and aerosols, also affect radiation incident on them by the processes of *absorption* and *scattering*. Scattering can be thought of as the process of changing the direction of the incident radiation—in some cases, by changing the frequency of the scattered radiation. The problem of scattering radiation without changing its frequency is the main topic of these notes.

The relative proportion of the incident radiation which is scattered in various directions by the scattering particles is a function of basically two parameters: the size of the particle relative to the wavelength of the incident radiation, and the (complex) index of refraction of the material of which the particle is made. The shape of the particle is also quite important, but the theory developed thus far, the Mie theory, is reasonably complete only for spherical particles, although particles of cylindrical and flat plate geometries have recently been addressed with some success. The basic parameters resulting from these analyses are the particle's *phase function*, which describes the spatial distribution of the scattered radiation, the *scatter cross section*, which determines the fraction of the incident radiation which is scattered, and the *absorption cross section*, which, for particles with a nonzero imaginary index of refraction, defines the fraction of the incident radiation that is absorbed by the particle.

The determination of these parameters is a subject of its own and will not be addressed in these notes—here, these parameters will be assumed to be known. The text by Liou, cited earlier, gives a good introduction to this subject, and the classical texts of van de Hulst (1957) and Deirmendjian (1969) should be consulted for more details. The texts by Kerker (1969) and Stratton (1941) are also quite readable and useful, and the excellent review paper by Hansen and Travis (1974) covers the scattering problem very concisely, as well as many of the other topics presented in the present text.

The theory of radiant energy propagation can generally be considered from two different viewpoints: classical electromagnetic wave theory, and quantum mechanics.

The classical theory begins with Maxwell's equations and considers the energy propagation characteristics of electromagnetic waves. However, the classical theory generally ignores the microscopic interactions of the radiation with matter, and treats only the *macroscopic* behavior. Consequently, many of the parameters of interest in the study of the propagation of radiation through absorbing, scattering, and emitting media are *defined* quantities which must be determined through experiment.

The situation is quite similar to that found in classical thermodynamics. Acceptance of the first and second laws of thermodynamics, an introduction of the perfect gas law, and the concept of entropy allow a great many mathematical statements to be made which correctly identify basic trends and gross features of thermodynamic systems in equilibrium. These classical concepts by themselves, however, generally do not permit the detailed calculation of numerical results. Certain concepts and groups of parameters are related to others through arbitrary constants of proportionality which must be experimentally determined. Such parameters as specific heats, heat transfer, diffusion coefficients, thermal conductivity, and viscosity coefficients are merely "constants of proportionality," and classical thermodynamics offers no means of directly computing their numerical magnitudes from first principles or of predicting the way in which these parameters will vary with such macroscopic thermodynamic properties as temperature, pressure, etc.

Classical statistical mechanics does attack these problems within the framework of classical physics by making some hypotheses concerning the molecular structure of the material; i.e., it assumes a mathematical "model" of the system. In this way, many of the above-mentioned coefficients can be computed in terms of the modeled physical properties of the molecules and the local properties of the system. These results, which are to a greater or lesser extent constrained by the fidelity of the assumed model, generally can predict the gross characteristics of these coefficients adequately and, when applied to systems which are known to fall within the realm of "classical physics," predict numerical magnitudes reasonably well. However, ultimately, an appeal to *quantum statistical mechanics* must be made to account for behavior which classical theory cannot handle. Unfortunately, the mathematical structure of these equations is generally very complex, and much of the insight offered by the classical theory is lost.

Initially, we shall adopt the quantum mechanical approach for the analysis of the radiation field. That is, we shall consider the field to be composed of photons rather than waves, and shall define the basic properties of the field in these terms. However, frequently an appeal to the classical approach will be made in the interest of clarity or expediency. For example, while the basic property of the radiation field, the spectral intensity, will be defined from the photon model, the concepts of absorption and emission coefficients will be introduced in classical terms as constants of proportionality in equations which describe the changes in spectral intensity as the radiation passes through and interacts with an optically active medium. The two approaches will also be combined in the derivation of the basic radiative

transfer equation, where the absorption and emission coefficients will be related to the annihilation and production of photons.

The concepts of absorption and emission coefficients can be developed by a formal quantum mechanical approach which relates the absorption and emission properties of the medium to the Einstein Transition Probability coefficients, which ultimately permit their calculation in terms of the microscopic properties of the medium.

Definitions

The initial concepts to be presented below are those which for the writer were initially the most difficult to understand and to relate to physically meaningful ideas. Consequently, extreme and frequently painful notational rigor will be adhered to initially, and parenthetical references to variable dependencies will be used in abundance. Both of these cumbersome nuisances will be relaxed or dropped in subsequent sections, as familiarity with their concepts and implications will hopefully have been attained by then.

Suppose one has an arbitrary volume, V , which contains N photons. These photons all travel with the speed of light, c , but they have definite distributions of energy and directions of motion. If the volume is assumed to be in thermodynamic equilibrium, the energy distribution is given by the well-known *Planck function*,

$$B_\nu(T) = \frac{2h\nu^3}{c^2[\exp(h\nu/kT) - 1]}$$

in which h is *Planck's constant*, 6.626×10^{-34} joule-sec, c is the velocity of light, 2.998×10^8 m/sec, k is *Boltzmann's constant*, 1.381×10^{-23} joule/deg, ν is the frequency in hertz, and T is the absolute temperature in kelvins. Then, $B_\nu(T)$ has dimensions of watts/(m²-sec-st). We also follow Planck in postulating that if a particular photon has a frequency associated with it, then the energy of the photon is $h\nu$.

Now consider the quantity n , where $n = N/V$ is the total number of photons per unit volume, with all permissible energies and traveling in all directions. Of all these photons, let us single out all the ones whose energies lie in the range $h\nu$ to $h(\nu + d\nu)$, and let n_ν symbolize these selected photons. Obviously, then,

$$n = \int_0^\infty n_\nu d\nu \quad (1-1)$$

Let us further restrict our selection of photons to all of the n_ν photons which are traveling in a specified direction defined by the unit vector Ω ,

and which lie in a differential solid angle centered on Ω . (See fig. 1-1.) From this, we define a *photon distribution function*, f_ν , as the number of photons per unit volume having the direction of propagation Ω within the solid angle $d\Omega$, whose energies lie in the range of $h\nu$ to $h(\nu + d\nu)$, and which are passing through a unit area in a unit time. Then,

$$n_\nu = \int f_\nu(\Omega) d\Omega \quad (1-2)$$

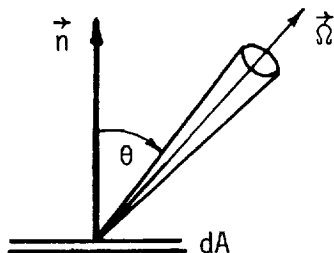

Figure 1-1. Solid angle and direction of travel of the selected f_ν photons.

Now, if we consider the area element dA whose normal \hat{n} makes an angle θ with the Ω -vector, then $dA \cos \theta$ is the projected area of dA normal to the direction of propagation Ω . If the photons are traveling with a velocity c then in time dt the total volume enclosing all the photons which have passed through dA in the direction of Ω is $(dA \cos \theta) (c dt)$, and thus, the number of selected photons in this volume is $cf(\Omega) \cos \theta dA dt d\nu d\Omega$. Since each photon has an energy $h\nu$, the total energy of all the selected photons is

$$dW_\nu = h\nu c f_\nu(\Omega) \cos \theta dA dt d\nu d\Omega \quad (1-3)$$

From this basic expression we can extract all of the definitions we need for our development, and hopefully for understanding other writers' definitions.

First of all

$$I_\nu(\Omega) = \frac{dW_\nu}{(dA \cos \theta) dt d\nu d\Omega} = h\nu c f_\nu(\Omega) \quad (1-4)$$

is defined as the *spectral intensity* or *radiance*, and is, at least in theoretical developments, perhaps the most fundamental and useful property of a radiation field. It can be seen that the radiance is defined as the total energy per unit time in the frequency interval $d\nu$ crossing

the unit projected surface area normal to the direction of propagation and in the infinitesimal solid angle centered around the direction of propagation.

Also from equation (1-3) we write

$$d\rho_\nu = \frac{dW_\nu}{(dA \cos \theta)(c dt)d\nu} = h\nu c f_\nu(\Omega) d\Omega$$

and so

$$\rho_\nu = \int h\nu f_\nu(\Omega) d\Omega \quad (1-5)$$

is the total energy per unit volume of all the photons whose energy range is $h\nu$ to $h(\nu + d\nu)$, but which are traveling in *any* direction. This is called the *spectral energy density*, and can be related to the radiance, $I_\nu(\Omega)$, by the use of equation (1-4)

$$\rho_\nu = \frac{1}{c} \int I_\nu(\Omega) d\Omega \quad (1-6)$$

We now accept $I_\nu(\Omega)$ as our fundamental parameter, write equation (1-3) in terms of this parameter, and use

$$dW_\nu = I_\nu(\Omega) dA \cos \theta dt d\Omega d\nu \quad (1-7)$$

as our basic equation. This equation is frequently presented as an intuitive relation, relating the total energy functionally to the area element, frequency, and the direction of propagation, in which case the radiance is frequently inserted as merely a constant of proportionality—hardly an auspicious introduction for such an important parameter. It can be seen from equation (1-4), however, that the radiance can be defined from more fundamental principles, and has a real physical identity of its own.

The quantity

$$e_\nu(\Omega) = \frac{dW_\nu}{dA dt d\Omega d\nu} = I_\nu(\Omega) \cos \theta \quad (1-8)$$

is called the *spectral emissive power*. This is the total energy per unit time in the frequency interval $d\nu$ crossing the *total* unit area into the unit solid angle centered about the direction of propagation Ω , and is a function of θ , as distinct from the definition of $I_\nu(\Omega)$.

From equations (1-7) and (1-8) the quantity

$$dF_\nu = \frac{dW_\nu}{dA dt d\nu} = I_\nu(\Omega) \cos \theta d\Omega$$

or

$$F_\nu = \int I_\nu(\Omega) \cos \theta \, d\Omega \quad (1-9)$$

is called the *spectral flux* or *irradiance*, and is probably the second most useful property describing the radiation field. This is the total energy within the frequency range $d\nu$, passing through the unit area per unit time, traveling in all possible directions.

Lastly, we define

$$dE = \frac{dW_\nu}{dA \, dt} = I_\nu(\Omega) \cos \theta \, d\Omega \, d\nu$$

or

$$E = \iiint I_\nu(\Omega) \cos \theta \, d\Omega \, d\nu = \int F_\nu \, d\nu \quad (1-10)$$

as the *total emissive power*. This is the total energy, or total flux per unit volume at all frequencies and in all directions passing through the unit area in unit time.

This completes the set of basic definitions. It is hoped that by appealing to the corpuscular approach, rather than the classical concept of waves with their associated energies and intensities, the above definitions will be easier to grasp.

As somewhat of an important aside, let us now make the assumption that all directions of motion of the photons are equally probable. This defines the concept of *isotropy* of radiation, and is one of the characteristics of *blackbody radiation*. All of the definitions given thus far are perfectly general and apply to any radiation field. In an isotropic field, some of these appear in a simpler algebraic form which will perhaps assist the reader to recall their physical significance.

From equation (1-2), $n_\nu = 4\pi f_\nu$, or

$$f_\nu = \frac{n_\nu}{4\pi} \quad (1-11)$$

or, the number of photons per unit volume in the direction of any solid angle is equal to the total number of photons per unit volume divided by the area of the unit sphere; i.e., the directions of travel are uniformly distributed over the unit sphere. From equation (1-6)

$$\rho_\nu = \frac{4\pi I_\nu}{c} \quad (1-12)$$

and using equations (1-4) and (1-11)

$$\rho_\nu = 4\pi h\nu f_\nu(\Omega) = h\nu n_\nu \quad (1-13)$$

The energy density of all photons in the frequency interval $d\nu$ traveling in any direction is equal to the energy per photon, $h\nu$, times the number of selected photons.

From equation (1-9)

$$F_\nu = \int I_\nu(\Omega) \cos \theta \, d\Omega = I_\nu \int_0^{2\pi} \int_0^{\pi/2} \cos \theta \sin \theta \, d\theta \, d\phi \quad (1-14)$$

$$F_\nu = \pi I_\nu \quad (1-15)$$

and from equation (1-10)

$$E = \pi I \quad (1-16)$$

where $I = \int_0^\infty I_\nu \, d\nu$ is called the *total intensity*, so that the total emissive power E bears the same relationship to the total intensity I as the radiant flux F_ν bears to the radiance I_ν . Note in equations (1-4) and (1-14) that the upper limit in the θ integral is $\pi/2$ rather than π . This is because these quantities are usually defined in the literature relative to an emitting *surface*, and hence can only emit into a hemisphere centered on the elemental area. Thus F_ν is sometimes called the *hemispherical spectral radiant flux*—quite a mouthful—and E is sometimes called the *hemispherical total emissive power*. Note, however, that the *net* flux is found by integrating over the whole unit sphere.

Substituting equation (1-12) into equation (1-16)

$$E = \frac{c}{4} \int \rho_\nu \, d\nu \quad (1-17)$$

and using equation (1-13)

$$E = \frac{c}{4} \int h\nu n_\nu \, d\nu \quad (1-18)$$

Finally, using equation (1-12) to eliminate I in equation (1-15)

$$F_\nu = \frac{c}{4} \rho_\nu \quad (1-19)$$

which relates the spectral radiant flux to the spectral energy density.

Up to this point, we have used a somewhat quantum mechanical approach, in that we have considered the radiation field to be composed of photons rather than waves, as in the classical approach. All of the previous equations and their relationships to one another could have been derived from classical electromagnetic theory, naturally, and in fact historically have been derived in just this manner.

We will now shift temporarily to a more macroscopic approach in the sense that we will define some quantities which are used to describe the way radiation energy interacts with the medium through which it is propagating in terms of experimentally derived characteristics rather than formal analysis. We will find that certain observed properties of the radiation field are related to certain properties of the medium, and prescribe certain constants of proportionality to form useful mathematical relationships. Classically, these constants are found by experiment, much the same way some of the classical thermodynamic coefficients mentioned earlier are found. Quantum mechanically, they can, at least in theory, be derived from considerations of the molecular structure of the medium and the electromagnetic interactions between the field produced by the medium and that produced by the radiation.

Absorption of Radiation

Consider a beam of monochromatic radiation of specific intensity $I_\nu(\mathbf{r}, \Omega')$; note, we now include the spatial dependence \mathbf{r} —confined to an element of solid angle $d\Omega'$ that is incident normal to the surface dA of a slab of optically active material of thickness ds . (See fig. 1-2.) As the radiation passes through the slab, some of the photons will be *absorbed* by the material in the slab, some will be *scattered* out of the beam by the material, and the rest will emerge from the opposite face of the slab. We confine ourselves for the present to the photons which are absorbed. Define $K_\nu(\mathbf{r})$ as the *spectral volumetric absorption coefficient*. This coefficient has units of m^{-1} , and represents the fraction of the incident radiation that is absorbed by the matter in the slab per unit length along the path of the incident radiation. Then, the total amount of radiation absorbed by the slab per unit time, per unit frequency interval in the solid angle $d\Omega'$ is

$$K_\nu(\mathbf{r}) I_\nu(\mathbf{r}, \Omega') d\Omega' dA ds \quad (1-20)$$

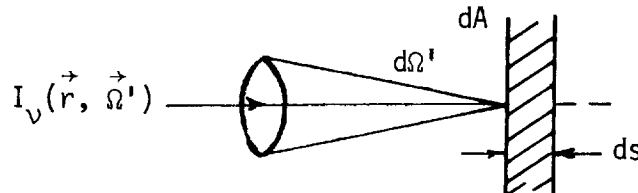

Figure 1-2. Infinitesimal cone of radiation intensity impinging on a thin slab.

It can be shown (e.g., Sparrow and Cess, pp. 17-18) that $1/K_\nu(\mathbf{r})$ can be interpreted as the mean free path for photon absorption; i.e., $1/e$

of the incident photons will be absorbed within a distance of $1/K_\nu(\mathbf{r})$ of the front surface.

The volumetric absorption coefficient can be related to the more commonly used *molecular absorption coefficient*, $K_\nu^m(\mathbf{r})$, and the *mass absorption coefficient*, $K_\nu^d(\mathbf{r})$, as follows: assume that the optically active material in the slab has a number density of $n_m(\mathbf{r})$ molecules/m³. Each molecule has an absorption cross section of $K_\nu^m(\mathbf{r})$ m²/molecule associated with it. Then the total absorption of the incident radiation in the length ds will be

$$K_\nu^m(\mathbf{r})I_\nu(\mathbf{r}, \Omega') d\Omega' n_m(\mathbf{r}) dA ds \quad (1-21)$$

Comparison of equation (1-20) with equation (1-21) reveals that

$$K_\nu(\mathbf{r}) = K_\nu^m(\mathbf{r})n_m(\mathbf{r}) \quad (1-22)$$

Similarly, if the optically active material has a mass density of ρ_m kg/m³, then the analogue to equation (1-21) is

$$K_\nu^d(\mathbf{r})I_\nu(\mathbf{r}, \Omega') d\Omega' \rho_m(\mathbf{r}) dA ds \quad (1-23)$$

and

$$K_\nu(\mathbf{r}) = K_\nu^d(\mathbf{r})\rho_m(\mathbf{r}) \quad (1-24)$$

Note that the units for K_ν^m are m²/molecule, and for K_ν^d are m²/kg.

Scattering of Radiation

In addition to the attenuation of the incident beam by absorption, some of the photons of the incident beam are removed by the process of scattering. Let $\sigma_\nu(\mathbf{r})$ denote the *spectral volumetric scattering coefficient*. This coefficient has dimensions of m⁻¹, and represents the fraction of the incident radiation that is scattered by the optically active material in the slab, *in all directions*, per unit length in the slab. Thus, the quantity

$$\sigma_\nu(\mathbf{r})I_\nu(\mathbf{r}, \Omega') d\Omega' \quad (1-25)$$

is the amount of incident radiation scattered in a unit length by the matter in all directions, per unit time and per unit frequency centered about ν .

This relation does not supply any information about the directional distribution of the scattered radiation. We therefore introduce the

concept of the *phase function*, $P_\nu(\mathbf{\Omega}, \mathbf{\Omega}')$, such that

$$\frac{1}{4\pi} P_\nu(\mathbf{\Omega}, \mathbf{\Omega}') d\Omega \quad (1-26)$$

describes the *probability* that the incident radiation, $I_\nu(\mathbf{r}, \mathbf{\Omega}')$, will be scattered from the solid angle $d\Omega'$ centered about $\mathbf{\Omega}'$ into an element of solid angle $d\Omega$ centered about the direction of $\mathbf{\Omega}$. The factor 4π is the total solid angle, and is introduced for normalization

$$\frac{1}{4\pi} \int_{\Omega} P_\nu(\mathbf{\Omega}, \mathbf{\Omega}') d\Omega = 1 \quad (1-27)$$

which says that *all* of the scattered radiation must go *somewhere* in the unit sphere.

We should note that some authorities, notably Chandrasekhar, define the integral in equation (1-27) as

$$\frac{1}{4\pi} \int_{\Omega} P_\nu(\mathbf{\Omega}, \mathbf{\Omega}') d\Omega = \tilde{\omega}_\nu$$

where $\tilde{\omega}_\nu$ is the *single-scattering albedo*, a concept to be introduced later, and thus represents the fraction of the total incident energy lost from the beam due to scattering only. Many authorities currently follow this practice; nonetheless, more and more experts seem to be adopting equation (1-27), which is preferable, in this writer's opinion, as it allows the parameter $\tilde{\omega}_\nu$ to be injected into the formal Radiative Transfer Equation (RTE) somewhat less artificially. Hence equation (1-27) is the definition used in the next chapter when deriving the RTE.

Putting equations (1-25) and (1-26) together, then,

$$[\sigma_\nu(\mathbf{r}) I_\nu(\mathbf{r}, \mathbf{\Omega}') d\Omega'] \left[\frac{1}{4\pi} P_\nu(\mathbf{\Omega}, \mathbf{\Omega}') d\Omega \right]$$

is the amount of the incident radiation which is scattered by the slab per unit time, volume, etc., into an element of solid angle $d\Omega$ centered about $\mathbf{\Omega}$. Integrating this expression over all angles of incidence gives

$$\frac{1}{4\pi} \sigma_\nu(\mathbf{r}) d\Omega \int_{\Omega'} I_\nu(\mathbf{r}, \mathbf{\Omega}') P_\nu(\mathbf{\Omega}, \mathbf{\Omega}') d\Omega' \quad (1-28)$$

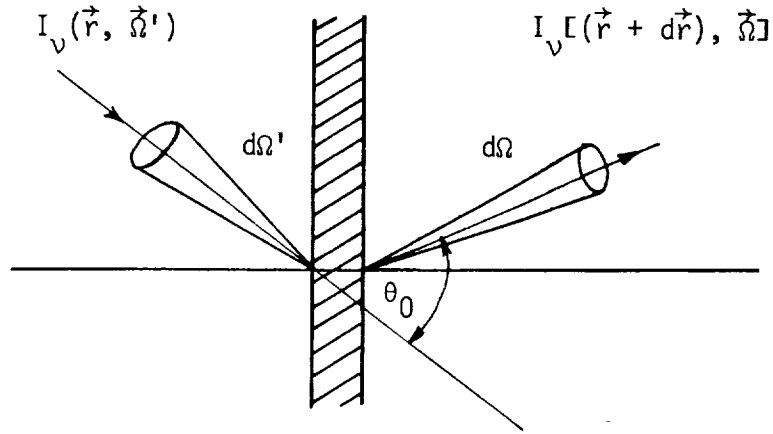

Figure 1-3. Geometry of the scattering process. The angle θ_0 is the scatter angle.

which is the total radiation scattered into the element $d\Omega$ from all directions of incidence per unit time, etc.

Figure 1-3 shows the geometry of the scattering process. The angle θ_0 is called the *scattering angle* (what else?). One usually assumes that the phase function depends *only* on the scattering angle. In that case, one usually writes

$$P_\nu(\Omega, \Omega') = P_\nu(\cos \theta_0) \quad (1-29)$$

and hence writes equation (1-28) as

$$\frac{1}{4\pi} \sigma_\nu(\mathbf{r}) d\Omega \int_0^{2\pi} \int_0^{\pi/2} I_\nu(\mathbf{r}, \theta', \phi') P_\nu(\cos \theta_0) d\theta' d\phi' \quad (1-30)$$

where the angles θ' and ϕ' are the usual colatitude and azimuthal polar coordinates. (See fig. 1-4.) Letting θ and ϕ represent the corresponding quantities for the scattered ray, we can write the expression for the unit vectors Ω and Ω' ,

$$\Omega = \begin{bmatrix} \sin \theta \cos \phi \\ \sin \theta \sin \phi \\ \cos \theta \end{bmatrix} \quad \Omega' = \begin{bmatrix} \sin \theta' \cos \phi' \\ \sin \theta' \sin \phi' \\ \cos \theta' \end{bmatrix} \quad (1-31)$$

Then, since $\cos \theta_0 = \Omega \cdot \Omega'$,

$$\cos \theta_0 = \cos \theta \cos \theta' + \sin \theta \sin \theta' \cos(\phi' - \phi) \quad (1-32)$$

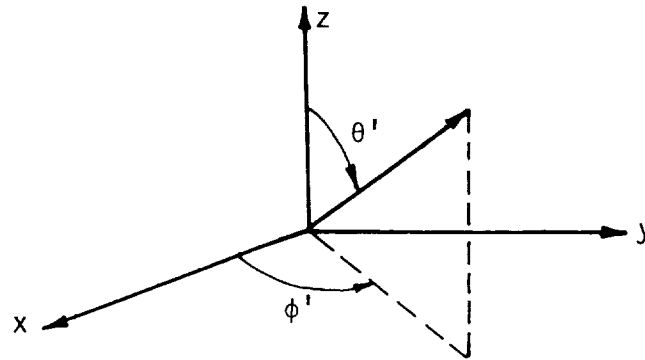

Figure 1-4. Spherical coordinate system used to define the scattering angle. The z -axis is normal to the slab.

or, as it is usually written, with $\mu = \cos \theta$

$$\mu_0 = \mu\mu' + (1 - \mu^2)^{1/2} (1 - \mu'^2)^{1/2} \cos(\phi' - \phi) \quad (1-33)$$

It might be worthwhile to elaborate somewhat on the form of the phase function as given by equation (1-29), even though some of the ideas we use will not be formally introduced until a later section. We are interested here in the form of the phase function when it is a function of the scattering angle only, and not a function of azimuth. This is a constraint that is almost universally applied in the literature.

For most atmospheric applications, the phase function has a shape which generally resembles the sketch in figure 1-5—the figure is rotationally symmetric. The scatter function generally has a small backscatter component (a), one or more “side-lobes” of various angular arrangements and magnitudes (b), and generally a strongly forward-scattering peak (c). The ratio of forward to backward scattering may in many cases exceed several hundreds.



Figure 1-5. Sketch showing a typical scatter pattern. For most materials, the figure is rotationally symmetric about the slab.

Generally in radiative transfer work, one tries to expand the phase function in a series of Legendre polynomials (see the expansion of eq. (2-31)):

$$P(\cos \theta_0) = \sum_{j=0}^N \tilde{\omega}_j P_j(\cos \theta_0) \quad (\tilde{\omega}_0 = 1) \quad (1-34)$$

with $\cos \theta_0$ given by equation (1-33). It is quite obvious that the more forward scattering we have, the more terms in equation (1-34) may be required to accurately describe the phase function; i.e., N may have to be several hundred.

In all of what follows, we shall not be quite so ambitious in our expansions. Practically all of the authorities from whose work most of the remaining text is drawn content themselves with at most two or three terms of equation (1-34). This makes the mathematics tenable and makes the physics of the process much more transparent in the resulting equations. Also, somewhat surprisingly, the numerical results are not too bad, and are of acceptable accuracy for many applications—for example, in climate modeling.

Start with the one-term expansion

$$P(\cos \theta_0) = 1 \quad (1-35)$$

which is obviously the simplest possible case, and which describes the very important case of *isotropic* scattering—i.e., scattering that is the same in all directions. The reader should not dismiss this simple case as being too elementary to be useful. Many radiative transfer processes are in fact very nearly isotropic and can be adequately studied by means of this analysis. Moreover, the comparatively simple solutions which follow from this assumption can be extrapolated to more complex cases, as the use of so-called “similarity” transformations frequently permits a transformation of variables from a more complex anisotropic case to an equivalent isotropic form. (See chap. 7.)

Chandrasekhar presents some interesting results for the two-term expansion

$$P(\cos \theta_0) = 1 + \tilde{\omega}_1 \cos \theta_0 \quad (1-36)$$

The three-term expansion

$$P(\cos \theta_0) = 1 + \tilde{\omega}_1 \cos \theta_0 + \tilde{\omega}_2 P_2(\cos \theta_0) \quad (1-37)$$

is also of particular interest, as for the special case in which $\tilde{\omega}_1 = 0$ and

$\bar{\omega}_2 = 1/2$; this reduces to the well-known *Rayleigh* phase function,

$$P(\cos \theta_0) = \frac{3}{4}(1 + \cos^2 \theta_0) \quad (1-38)$$

This phase function has equal forward and backward scatter peaks and is used to describe scatter phenomena by particles which are very small compared to the wavelength of the incident radiation. (See fig. 1-6.)

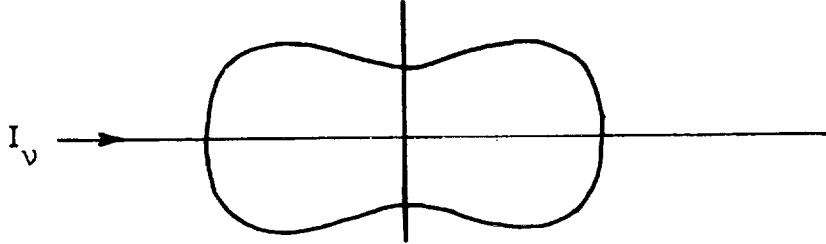

Figure 1-6. Sketch of the Rayleigh phase function. The figure is rotationally symmetric about the long axis.

Finally, the *Henyey-Greenstein* phase function is frequently used when a large forward-scattered peak is desired. This phase function is given by

$$P(\cos \theta_0) = \frac{1 - g^2}{(1 + g^2 - 2g \cos \theta_0)^{3/2}} \quad (-1 \leq g \leq +1) \quad (1-39)$$

where g is known as the *asymmetry parameter*, and controls the size of the forward peak. Equation (1-39) is particularly useful in theoretical studies involving asymmetric scattering because it is a generating function for Legendre polynomials and has the simple expansion

$$P(\cos \theta_0) = \sum_{n=0}^{\infty} (2n + 1)g^n P_n(\cos \theta_0) \quad (1-40)$$

Positive g gives a forward-scattering peak, while negative g gives a larger backward-scattered component. In order to achieve a better approximation to a given phase function, two or more expressions of the same type as equation (1-39) or equation (1-40), with different values of g , could be combined. Note that $g = 0$ in equation (1-39) or equation (1-40) gives the isotropic phase function.

The ratio of the size of the forward peak to the backward peak can be found from equation (1-39)

$$\frac{P(\theta_0 = 0)}{P(\theta_0 = \pi)} = \left(\frac{1 + g}{1 - g} \right)^3 \quad (1-41)$$

from which table 1-2 can be extracted. Many aerosols have ratios of forward- to backward-scattering peaks of the order of several hundreds, and can thus be adequately represented for many purposes by the Henyey-Greenstein phase function with g of the order of 0.65 to 0.70.

TABLE 1-2. RATIO OF FORWARD- TO BACKWARD-SCATTERING PEAKS FROM THE HENYEY-GREENSTEIN PHASE FUNCTION

g	$P(\theta_0 = 0)/P(\theta_0 = \pi)$
0.0	1.000
0.1	1.826
0.2	3.375
0.3	6.405
0.4	12.704
0.5	27.000
0.6	64.000
0.7	181.963
0.8	729.000
0.9	6859.000
1.0	∞

The azimuthal integration of equation (1-34) gives some particularly useful results. From the complete expansion given later in equation (2-32), this results in

$$P(\mu, \mu') = \frac{1}{2\pi} \int_0^{2\pi} P(\cos \theta_0) d\phi \quad (1-42)$$

It can be seen from equation (2-32) that all terms except those for $m = 0$ integrate to zero over the range of 0 to 2π , and we are left with

$$P(\mu, \mu') = \sum_{j=0}^{\infty} \tilde{\omega}_j P_j(\mu) P_j(\mu') \quad (1-43)$$

and this in the two-term expansion gives

$$P(\mu, \mu') = 1 + \tilde{\omega}_1 \mu \mu' \quad (1-44)$$

while the three-term Rayleigh expansion gives

$$P(\mu, \mu') = 1 + \frac{1}{8}(3\mu^2 - 1)(3\mu'^2 - 1) \quad (1-45)$$

a particularly simple and useful form.

The $\tilde{\omega}_1$ in equation (1-44) is related to the asymmetry parameter,

$$\langle \cos \theta_0 \rangle = \frac{1}{2} \int_{-1}^1 P(\cos \theta_0) \cos \theta_0 d \cos \theta_0 \quad (1-46)$$

for which, in the case of the Henyey-Greenstein phase function,

$$\langle \cos \theta_0 \rangle = g \quad (1-47)$$

For this case,

$$\tilde{\omega}_1 = 3g \quad (1-48)$$

It is important to grasp the conceptual differences between scattering and absorption. In the scattering process, the photon interacts with a particle of the medium in such a way that, macroscopically speaking, the direction of travel of the photon is altered, but (in all cases considered in these notes) its energy remains constant. It can be imagined that the photon “bounces off” the particle in a particular direction, with no exchange of energy with the scatterer. Thus, neither the internal nor the kinetic energy of the particle is changed, and consequently the “temperature” of the medium is unaffected by pure scattering.

In the absorption process, on the other hand, the energy of the photon is completely transferred to the particle, and the photon ceases to exist in its original form. The kinetic energy of the particle is thereby raised—the “temperature” of the medium increases. Emission is the opposite of absorption. The medium particle ejects a photon and the particle loses energy—the “temperature” of the medium decreases.

In general, a medium can absorb and emit radiation, and can scatter radiation, but only the absorbed or emitted portion of this energy, gained or lost from a given beam of radiance, can contribute to the energy change of the medium. In the present text, the term *conservative scattering* will refer to the process of pure scatter with no absorption or emission.

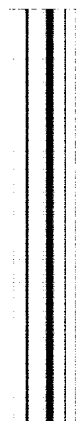

Chapter 2

The Equation of Transfer

We now derive the integro-differential equation which describes the total change in the spectral intensity, or radiance, as it traverses an infinitesimal distance through an optically active medium which can absorb, emit, and scatter electromagnetic energy in the wavelength interval $d\nu$ centered about ν . The equation will be derived first in a very general form, and then specialized to the various forms usually seen in the applications literature.

Consider an absorbing, scattering, and emitting medium whose optical properties are characterized by a spectral volumetric absorption coefficient, $K_\nu(s)$, and a spectral volumetric scattering coefficient, $\sigma_\nu(s)$, where s is the distance along the absorbing path. A beam of monochromatic radiation of spectral intensity $I(s, \Omega, t)$ travels through the medium in the direction Ω along the path ds , and is confined to the solid angle $d\Omega$ centered about the direction Ω . (See fig. 2-1.) We can write the outgoing intensity as

$$I_\nu(s, \Omega, t) + DI_\nu(s, \Omega, t) \quad (2-1)$$

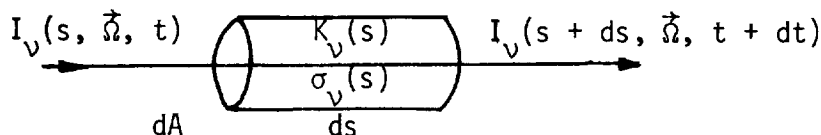

Figure 2-1. The change in intensity of a monochromatic beam of radiation as it passes through an optically active medium of length ds .

where the total differential term represents the difference between the intensity entering the left face of the slab and that leaving the right face.

Let W_ν denote the net gain or loss of radiation by the beam in this volume element per unit volume, time, etc. Then quantity

$$W_\nu dA ds d\Omega d\nu dt \quad (2-2)$$

PRECEDING PAGE BLANK NOT FILMED

23

PAGE 22 INTENTIONALLY BLANK

represents the net gain of radiant energy by the volume element. But, by definition of the radiance, I_ν , this is precisely equal to

$$DI_\nu(s, \Omega, t) dA d\Omega d\nu dt \quad (2-3)$$

and hence

$$\frac{DI_\nu(s, \Omega, t)}{Ds} = W_\nu \quad (2-4)$$

We have taken here an Eulerian approach to equation (2-4); i.e., we have assumed that we are stationary and are describing what goes on inside a fixed volume element $dA ds$ —hence, the use of the total or substantive derivation in equation (2-4). Equation (2-4) can be written in terms of the more common time and space derivatives by using the usual transformation

$$\frac{D}{Ds} = \frac{1}{c} \frac{D}{Dt} = \frac{1}{c} \left[\frac{\partial}{\partial t} + \mathbf{c} \cdot \nabla \right]$$

where $\mathbf{c} = c\Omega$ is the velocity of light (the velocity of the photons). Thus equation (2-4) becomes

$$\frac{1}{c} \frac{\partial I_\nu(s, \Omega, t)}{\partial t} + \Omega \cdot \nabla I_\nu(s, \Omega, t) = W_\nu \quad (2-5)$$

The second term is simply the directional derivative of I_ν in the direction s , so we get

$$\frac{1}{c} \frac{\partial I_\nu(s, \Omega, t)}{\partial t} + \frac{\partial I_\nu(s, \Omega, t)}{\partial s} = W_\nu \quad (2-6)$$

The net energy gain, W_ν , can be broken down into four separate pieces:

- W_{ν_1} energy emitted by the volume element
- W_{ν_2} energy absorbed by the element
- W_{ν_3} energy scattered out of the volume element
- W_{ν_4} energy scattered into the volume element from all directions

For now, let us simply denote the total energy emitted by the volume element into the direction Ω by

$$W_{\nu_1} = j_\nu^e(s, t) \quad (2-7)$$

The contribution W_{ν_2} is given by equation (1-20), written per unit volume and solid angle

$$W_{\nu_2} = -K_{\nu}(s)I_{\nu}(s, \mathbf{\Omega}, t) \quad (2-8)$$

W_{ν_3} is the loss of radiant energy scattered *out* of the incoming beam by the scatterers in the medium (see eq. (1-25))

$$W_{\nu_3} = -\sigma_{\nu}(s)I_{\nu}(s, \mathbf{\Omega}, t) \quad (2-9)$$

and W_{ν_4} , the energy scattered into the beam, is given by equation (1-30)

$$W_{\nu_4} = \frac{1}{4\pi}\sigma_{\nu}(s) \int_{\Omega'} P(\cos \theta_0)I_{\nu}(s, \mathbf{\Omega}', t) d\Omega' \quad (2-10)$$

Substitute equations (2-7) through (2-10) into equation (2-6)

$$\begin{aligned} \frac{1}{c} \frac{\partial I_{\nu}(s, \mathbf{\Omega}, t)}{\partial t} + \frac{\partial I_{\nu}(s, \mathbf{\Omega}, t)}{\partial s} = & j_{\nu}^e(s, t) - K_{\nu}(s)I_{\nu}(s, \mathbf{\Omega}, t) - \sigma_{\nu}(s)I_{\nu}(s, \mathbf{\Omega}, t) \\ & + \frac{1}{4\pi}\sigma_{\nu}(s) \int_{\Omega'} P(\cos \theta_0)I_{\nu}(s, \mathbf{\Omega}', t) d\Omega' \end{aligned} \quad (2-11)$$

and equation (2-11) is the radiative transfer equation (RTE) in its most general form for our purposes.

For practically all atmospheric propagation problems, the first term on the left-hand side of equation (2-11) is many orders of magnitude smaller than the other terms, and can safely be dropped from further discussion.

The term $j_{\nu}^e(s, t)$, which represents energy added to the emerging beam by emission, and the integral scattering term, which represents energy added to the emerging beam through scattering, are usually combined to give what is usually referred to as the *source term*, j_{ν} , which represents the total energy added to the beam by emission and in-scattering:

$$j_{\nu} = j_{\nu}^e(s, t) + \frac{1}{4\pi}\sigma_{\nu}(s) \int_{\Omega'} P(\cos \theta_0)I_{\nu}(s, \mathbf{\Omega}', t) d\Omega' \quad (2-12)$$

and hence, we can write equation (2-11) in the form

$$\frac{dI_\nu(s, \Omega)}{ds} = j_\nu - K_\nu(s)I_\nu(s, \Omega) - \sigma_\nu(s)I_\nu(s, \Omega) \quad (2-13)$$

in which the time-dependent term has been dropped. Note that we have switched to a total derivative notation in equation (2-13). This is not strictly correct, as I_ν is a function of more than one variable. However, this is a convention that has been adopted in the RTE literature, and hence will be adopted here.

Finally, we divide through $K_\nu(s) + \sigma_\nu(s)$ and write equation (2-13) as

$$\frac{1}{K_\nu(s) + \sigma_\nu(s)} \frac{dI_\nu(s, \Omega)}{ds} + I_\nu(s, \Omega) = J_\nu(s, \Omega) \quad (2-14)$$

where

$$J_\nu = \frac{j_\nu}{K_\nu(s) + \sigma_\nu(s)} \quad (2-15)$$

is referred to as the *source function*.

Equation (2-14) is very general. We now make a very important assumption, namely, that the volume element is in *local thermodynamic equilibrium* (LTE) with the surrounding medium. This LTE assumption is valid in most atmospheric problems, at least below 30 to 50 km. Then, Kirchhoff's law allows us to define j_ν^e in terms of the Planck function, $B_\nu(T)$,

$$j_\nu^e = K_\nu(s)B_\nu(T) \quad (2-16)$$

where T is the absolute temperature of the medium in the volume element $dA ds$. The source term then becomes

$$j_\nu = K_\nu(s)B_\nu(T) + \frac{1}{4\pi} \sigma_\nu(s) \int_{\Omega'} P(\cos \theta_0) I_\nu(s, \Omega') d\Omega' \quad (2-17)$$

Define the *spectral volumetric extinction coefficient*,

$$\beta_\nu(s) = K_\nu(s) + \sigma_\nu(s) \quad (2-18)$$

and the ratio

$$\tilde{\omega}_\nu = \frac{\sigma_\nu(s)}{\beta_\nu(s)} \quad (2-19)$$

$\tilde{\omega}_\nu$ is called the *single-scattering albedo*, or the *particle albedo*, and expresses the fraction of the attenuated beam which is lost to scattering alone. In terms of $\tilde{\omega}_\nu$,

$$\frac{K_\nu(s)}{\beta_\nu(s)} = 1 - \tilde{\omega}_\nu \quad (2-20)$$

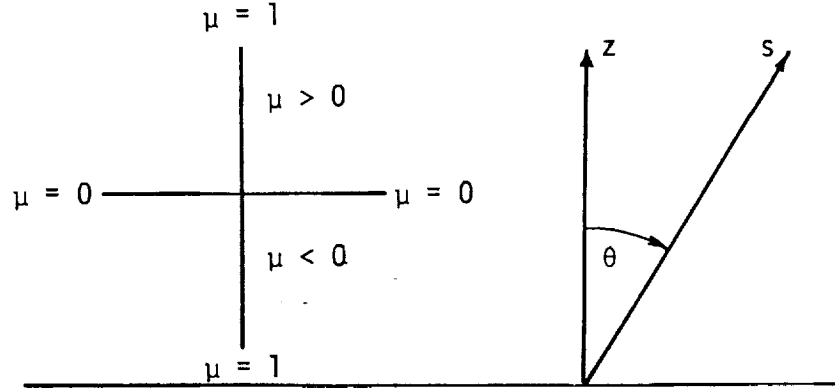

Figure 2-2. Geometry of plane-parallel atmosphere. The direction z is measured upward from the planet surface. Positive μ denotes upward-traveling radiation.

and hence, we can write equation (2-14) as

$$\frac{1}{\beta_\nu(s)} \frac{dI_\nu(s, \Omega)}{ds} + I_\nu(s, \Omega) = J_\nu(s, \Omega) \quad (2-21)$$

where the source function is

$$J_\nu(s, \Omega) = (1 - \tilde{\omega}_\nu)B(T) + \frac{\tilde{\omega}_\nu}{4\pi} \int_{\Omega'} P(\cos \theta) I_\nu(s, \Omega') d\Omega' \quad (2-22)$$

The RTE in Plane-Parallel Atmospheres

We now further confine our attention to the passage of radiation through a plane-parallel medium. This is a medium which is stratified in planes perpendicular to a given direction z , such that the optical properties of the medium are functions of z and ν only. Since the thickness of a planetary atmosphere is generally small compared with its radius, this assumption is almost universally made in applications of the RTE to atmospheric radiation studies. Now, $d(\)/ds = \cos \theta d(\)/dz = \mu d(\)/dz$ (see fig. 2-2), so that we can rewrite equations (2-21) and (2-22) in terms of z , μ , and ϕ :

$$\frac{\mu}{\beta_\nu(z)} \frac{dI_\nu(z, \mu, \phi)}{dz} + I_\nu(z, \mu, \phi) = J_\nu(z, \mu, \phi) \quad (2-23)$$

Here, in J_ν ,

$$d\Omega' = \sin \theta' d\theta' d\phi' = -d\mu' d\phi' \quad (2-24)$$

so that

$$J_\nu(z, \mu, \phi) = (1 - \tilde{\omega}_\nu) B_\nu[T(z)] - \frac{\tilde{\omega}_\nu}{4\pi} \int_0^{2\pi} \int_{+1}^{-1} P(\cos \theta_0) I_\nu(z, \mu', \phi') d\mu' d\phi' \quad (2-25)$$

It is also convenient at this time to introduce the concept of *optical depth*, τ_ν , defined to be

$$\tau_\nu = \int_z^\infty \beta_\nu(z') dz' \quad d\tau_\nu = -\beta_\nu(z) dz \quad (2-26)$$

Note that the optical depth is defined to be zero at the *top* of the atmosphere, and increases as one descends through the atmosphere, in the opposite direction from that in which z is defined. This convention is a carry-over from the astrophysical literature, where, in studying the radiative properties of stellar atmospheres, distance and optical parameters are measured positive from the surface of the star inwards. Since much of radiative transfer theory has been developed and published in connection with studies of stellar interiors, this convention has, for the most part, been adhered to in applications of radiative transfer theory to planetary atmospheres.

If the height variable z is replaced with the optical depth τ_ν , in equation (2-23) (see fig. 2-3), then

$$-\mu \frac{dI_\nu(\tau_\nu, \mu, \phi)}{d\tau_\nu} + I_\nu(\tau_\nu, \mu, \phi) = J_\nu(\tau_\nu, \mu, \phi)$$

or

$$\mu \frac{dI_\nu(\tau_\nu, \mu, \phi)}{d\tau_\nu} = I_\nu(\tau_\nu, \mu, \phi) - J_\nu(\tau_\nu, \mu, \phi) \quad (2-27)$$

with

$$J_\nu(\tau_\nu, \mu, \phi) = (1 - \tilde{\omega}_\nu) B_\nu[T(\tau_\nu)] + \frac{\tilde{\omega}_\nu}{4\pi} \int_0^{2\pi} \int_{-1}^1 P(\cos \theta_0) I_\nu(\tau_\nu, \mu', \phi') d\mu' d\phi' \quad (2-28)$$

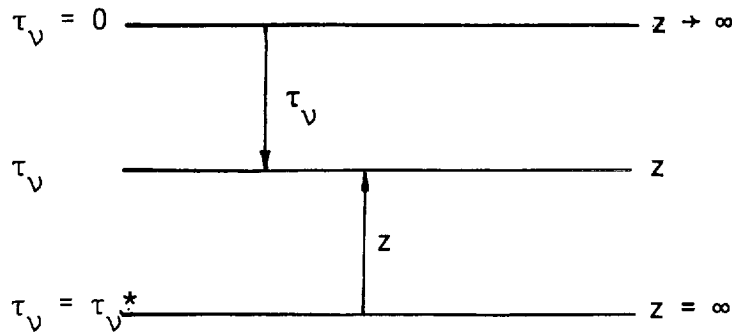

Figure 2-3. Sketch showing the relationship between the vertical coordinate z and the optical depth, τ_ν .

Further Specialized Forms

Two further specializations of equations (2-27) and (2-28) are frequently encountered.

First is the case where the emission term, $B_\nu [T(\tau_\nu)]$, is small and can be neglected. In this case, only scattering and absorption are included in the transfer process; this is the situation usually encountered in studying radiation emitted directly by the Sun. This radiation is absorbed and scattered by the Earth's atmosphere, but the atmosphere itself is cold compared to the Sun, and thus, at solar wavelengths its radiation is small compared with that emitted by the Sun. Thus, when the emission term is small, equations (2-27) and (2-28) are usually written as the single equation

$$\begin{aligned} \mu \frac{dI_\nu(\tau_\nu, \mu, \phi)}{d\tau_\nu} \\ = I_\nu(\tau_\nu, \mu, \phi) - \frac{\tilde{\omega}_\nu}{4\pi} \int_0^{2\pi} \int_{-1}^1 P(\cos\theta_0) I_\nu(\tau_\nu, \mu', \phi') d\mu' d\phi' \quad (2-29) \end{aligned}$$

Equation (2-29) and sundry of its equivalent forms will be the starting equation in much of what follows in these notes.

The second specialized case for equations (2-27) and (2-28) occurs in the IR spectral region, where it is the scattering which can be neglected (except in clouds). In the case of measuring IR radiation from the Earth's atmosphere, the emission term is the only source of radiation, and hence must be included. For this case, $\tilde{\omega}_\nu = 0$, and equations (2-27)

and (2-28) become

$$\mu \frac{dI_\nu(\tau_\nu, \mu, \phi)}{d\tau_\nu} = I_\nu(\tau_\nu, \mu, \phi) + B_\nu [T(\tau_\nu)] \quad (2-30)$$

Expansion of the RTE into Legendre Polynomials

Equation (2-29) is still extremely difficult to solve. Part of this difficulty is due to the azimuthal dependence of I_ν through the phase function. By expanding the phase function in a Legendre polynomial series, the azimuthally dependent terms in the function can be uncoupled. The form of the expansion will then suggest that the radiance should be expanded as a Fourier cosine series. The result of substituting these expansions in equation (2-29) is a set of uncoupled linear integro-differential equations for the various orders of expansion. From this, we will show that only the azimuthally independent equation contributes to the *flux* calculations. Since this is the parameter of greatest interest in most atmospheric applications, we can then confine our future attention to the solution of only this azimuthally independent equation.

First, we expand the phase function, equation (1-29), in a Legendre polynomial series of order N :

$$P(\cos \theta_0) = \sum_{j=0}^N \tilde{\omega}_j P_j(\cos \theta_0) \quad (\tilde{\omega}_0 = 1) \quad (2-31)$$

where $\cos \theta_0$ is given by equation (1-33). Then by the addition theorem for Legendre polynomials we can write equation (2-31) in terms of $\mu, \mu', \phi,$ and ϕ' :

$$P(\mu, \mu', \phi, \phi') = \sum_{m=0}^N \sum_{\ell=m}^N \tilde{\omega}_\ell^m P_\ell^m(\mu) P_\ell^m(\mu') \cos[m(\phi' - \phi)] \quad (2-32)$$

where

$$\tilde{\omega}_\ell^m = \tilde{\omega}_\ell (2 - \delta_0^m) \frac{(\ell - m)!}{(\ell + m)!} \quad \left(\begin{array}{l} 0 \leq m \leq N \\ \ell = m, m + 1, \dots, N \end{array} \right)$$

Substitute equation (2-32) into equation (2-29)

$$\begin{aligned} \frac{dI_\nu(\tau_\nu, \mu, \phi)}{d\tau_\nu} &= I_\nu(\tau_\nu, \mu, \phi) - \frac{\tilde{\omega}_\nu}{4\pi} \sum_{m=0}^N \sum_{\ell=m}^N \tilde{\omega}_\ell^m P_\ell^m(\mu) \\ &\times \int_0^{2\pi} \int_{-1}^1 P_\ell^m(\mu') I_\nu(\tau_\nu, \mu', \phi') \cos[m(\phi' - \phi)] d\mu' d\phi' \quad (2-33) \end{aligned}$$

Note that the phase function has separated into the product of a function of μ and μ' only, times a function of $(\phi' - \phi)$ in each term. This suggests that if we expand $I_\nu(\tau_\nu, \mu, \phi)$ in a Fourier cosine series in ϕ , we ought to be able to separate the azimuthally dependent terms from the azimuthally independent terms by equating like coefficients of $\cos m(\phi' - \phi)$. The direct sunlight, which is usually taken to be the source of the radiation in the atmosphere, is assumed to be directionally defined by the angles (θ_0, ϕ_0) (see fig. 2-4). Since most of the radiation will be along this direction, let us expand about this unit vector

$$I_\nu(\tau_\nu, \mu, \phi) = \sum_{m=0}^N I_\nu^m(\tau_\nu, \mu) \cos[m(\phi_0 - \phi)] \quad (2-34)$$

where the coefficient I_ν^m is a function only of τ_ν and μ but *not* of ϕ .

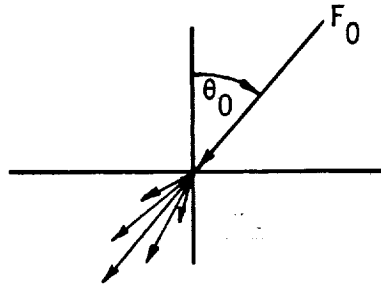

Figure 2-4. Sketch showing the scattering of an incoming collimated beam of solar radiation.

Substitute equation (2-34) into equation (2-33)

$$\begin{aligned}
 & \sum_{m=0}^N \mu \frac{dI_{\nu}^m(\tau_{\nu}, \mu)}{d\tau_{\nu}} \cos[m(\phi_0 - \phi)] \\
 &= \sum_{m=0}^N I_{\nu}^m(\tau_{\nu}, \mu) \cos[m(\phi_0 - \phi)] - \frac{\tilde{\omega}_{\nu}}{4\pi} \sum_{m=0}^N \sum_{\ell=m}^N \tilde{\omega}_{\ell}^m P_{\ell}^m(\mu) \int_0^{2\pi} \int_{-1}^1 P_{\ell}^m(\mu') \\
 & \quad \times \sum_{p=0}^N I_{\nu}^p(\tau_{\nu}, \mu') \cos[p(\phi_0 - \phi')] \cos[m(\phi' - \phi)] d\mu' d\phi' \quad (2-35)
 \end{aligned}$$

Examine the integral term of equation (2-35)

$$\begin{aligned}
 & \int_0^{2\pi} \int_{-1}^1 P_{\ell}^m(\mu') \sum_{p=0}^N I_{\nu}^p(\tau_{\nu}, \mu') \cos[p(\phi_0 - \phi')] \cos[m(\phi' - \phi)] d\mu' d\phi' \\
 &= \sum_{p=0}^N \int_{-1}^1 P_{\ell}^m(\mu') I_{\nu}^p(\tau_{\nu}, \mu') d\mu' \int_0^{2\pi} \cos[p(\phi_0 - \phi')] \cos[m(\phi' - \phi)] d\phi' \quad (2-36)
 \end{aligned}$$

Now

$$\begin{aligned}
 & \int_0^{2\pi} \cos[p(\phi_0 - \phi')] \cos[m(\phi' - \phi)] d\phi' \\
 &= 2\pi \quad (p = m = 0) \\
 &= \pi \cos m(\phi_0 - \phi) \quad (p = m \neq 0) \\
 &= 0 \quad (p \neq m)
 \end{aligned}$$

Thus, we are able to write the right-hand side of equation (2-36) as

$$(1 + \delta_0^m) \pi \cos m(\phi_0 - \phi) \int_{-1}^1 P_{\ell}^m(\mu') I_{\nu}^m(\tau_{\nu}, \mu') d\mu' \quad (2-37)$$

If we now substitute equation (2-37) into equation (2-35) and equate coefficients of $\cos[m(\phi_0 - \phi)]$ on both sides of the equation, we can write for the I_{ν}^m component

$$\begin{aligned}
 \mu \frac{dI_{\nu}^m(\tau_{\nu}, \mu)}{d\tau_{\nu}} &= I_{\nu}^m(\tau_{\nu}, \mu) - \frac{\tilde{\omega}_{\nu}}{4} (1 + \delta_0^m) \sum_{\ell=m}^N \tilde{\omega}_{\ell}^m P_{\ell}^m(\mu) \\
 & \quad \times \int_{-1}^1 P_{\ell}^m(\mu') I_{\nu}^m(\tau_{\nu}, \mu') d\mu' \quad (2-38)
 \end{aligned}$$

The definition of spectral flux, equation (1-14), can be written as

$$F_\nu(\tau_\nu) = \int_0^{2\pi} \int_0^\pi I_\nu(\tau_\nu, \theta, \phi) \cos \theta \sin \theta \, d\theta \, d\phi$$

or

$$F_\nu(\tau_\nu) = - \int_0^{2\pi} \int_{-1}^{-1} \mu' I_\nu(\tau_\nu, \mu', \phi') \, d\mu' \, d\phi' = \int_0^{2\pi} \int_{-1}^1 \mu' I_\nu(\tau_\nu, \mu', \phi') \, d\mu' \, d\phi' \quad (2-39)$$

Substitute equation (2-34) into equation (2-39)

$$\begin{aligned} F_\nu(\tau_\nu) &= \int_0^{2\pi} \int_{-1}^1 \mu \sum_{m=0}^N I_\nu^m(\tau_\nu, \mu) \cos[m(\phi_0 - \phi)] \, d\mu \, d\phi \\ &= \sum_{m=0}^N \int_{-1}^1 \mu I_\nu^m(\tau_\nu, \mu) \, d\mu \int_0^{2\pi} \cos[m(\phi_0 - \phi)] \, d\phi \end{aligned}$$

But this vanishes unless $m = 0$, in which case we get

$$F_\nu(\tau_\nu) = 2\pi \int_{-1}^1 \mu I_\nu^0(\tau_\nu, \mu) \, d\mu \quad (2-40)$$

This demonstrates that the flux depends only on the $m = 0$ term—that is, the azimuthally independent term of equation (2-38). So, we will now restrict all future developments to equation (2-38) with $m = 0$ and drop all the superscripts:

$$\mu \frac{dI_\nu(\tau_\nu, \mu)}{d\tau_\nu} = I_\nu(\tau_\nu, \mu) - \frac{\tilde{\omega}_\nu}{2} \sum_{\ell=0}^N \tilde{\omega}_\ell P_\ell(\mu) \int_{-1}^1 P_\ell(\mu') I_\nu(\tau_\nu, \mu') \, d\mu'$$

or in a somewhat prettier form

$$\mu \frac{dI_\nu(\tau_\nu, \mu)}{d\tau_\nu} = I_\nu(\tau_\nu, \mu) - \frac{\tilde{\omega}_\nu}{2} \int_{-1}^1 I_\nu(\tau_\nu, \mu') P(\mu, \mu') \, d\mu' \quad (2-41)$$

where

$$P(\mu, \mu') = \sum_{\ell=0}^N \tilde{\omega}_\ell P_\ell(\mu) P_\ell(\mu') \quad (2-42)$$

Equations (2-41) and (2-42) are the forms most frequently seen in the literature. Remember the restrictions, however:

1. No thermal emission,
2. plane-parallel atmosphere,
3. phase function expandable in Legendre polynomial series, and
4. azimuthal symmetry.

RTE for Diffuse Component Only

We now derive one other form frequently seen in the literature. In the preceding development, the term I_ν was considered to be the *total* spectral intensity. In problems of atmospheric physics, the assumption is usually made that the Sun's rays consist of a parallel, or collimated, beam of radiation hitting the top of the atmosphere at some direction specified by the angles θ_0 and ϕ_0 . Some of this radiation is multiply scattered and appears at various values of τ_ν in the form of *diffuse* radiation; i.e., radiation which has been multiply scattered and is now traveling in all directions. Another portion of the incoming solar beam is absorbed by the intervening atmosphere between the entry point and the current value of τ_ν . The remainder appears at τ_ν as *attenuated* solar radiation. This component is referred to as the *direct* component, traveling in the same direction as the incoming beam. In analysis, it is frequently convenient to separate these two components in equation (2-29) so that the resulting equations describe the behavior of the diffuse component only. This also simplifies in many ways the application of the boundary conditions.

So, let us write

$$I_\nu = I_\nu^D + I_\nu^S \quad (\text{diffuse} + \text{solar}) \quad (2-43)$$

As indicated above, the direct beam consists of photons which were originally in the incoming solar beam. These represent what is left over after all the scattering and absorption has taken place. It does *not* include photons which have been scattered out of the incoming beam and then scattered back into the original direction—these are part of the diffuse component. It also does not include photons emitted by the layers of the atmosphere above it—these are also part of the diffuse beam when, rarely, the emission terms are included in the RTE. Thus, the direct, or solar, beam satisfies its own differential equation, of the form

$$\mu \frac{dI_\nu^S(\tau_\nu, \mu, \phi)}{d\tau_\nu} = I_\nu^S(\tau_\nu, \mu, \phi) \quad (2-44a)$$

with the upper boundary condition prescribing the incident radiance to be a beam collimated in the direction (θ_0, ϕ_0)

$$I_\nu^S(0, -\mu_0, \phi_0) = \pi F_0 \delta(\mu - \mu_0) \delta(\phi - \phi_0)$$

Solving and applying the boundary condition yields the intensity for the direct beam in terms of the incoming solar flux, πF_0

$$I_\nu^S(\tau_\nu, -\mu, \phi) = \pi F_0 e^{-\tau_\nu/\mu_0} \delta(\mu - \mu_0) \delta(\phi - \phi_0) \quad (2-44b)$$

where the δ are Dirac delta functions. The factor π is frequently introduced into the solar flux because of the way Chandrasekhar defines the flux term. He defines the flux as

$$\pi F_\nu(\tau_\nu) = \int_0^{2\pi} \int_{-1}^1 \mu I_\nu(\tau_\nu, \mu) d\mu d\phi$$

rather than our definition in equation (2-39). The reason for this is that the factor π then cancels out of both sides of many of the flux equation forms, thus eliminating the necessity of carrying the π -factor through a lot of theoretical development.

Now, put equation (2-43) into equation (2-29)

$$\begin{aligned} \mu \frac{dI_\nu^D(\tau_\nu, \mu, \phi)}{d\tau_\nu} + \mu \frac{dI_\nu^S(\tau_\nu, \mu, \phi)}{d\tau_\nu} &= I_\nu^D(\tau_\nu, \mu, \phi) + I_\nu^S(\tau_\nu, \mu, \phi) \\ &\quad - \frac{\tilde{\omega}_\nu}{4\pi} \int_0^{2\pi} \int_{-1}^1 P(\mu, \phi; \mu', \phi') \left[I_\nu^D(\tau_\nu, \mu', \phi') \right. \\ &\quad \left. + I_\nu^S(\tau_\nu, \mu', \phi') \right] d\mu' d\phi' \end{aligned} \quad (2-45)$$

From the differential equation (2-44a), the second term on the right-hand side and the second term on the left-hand side of equation (2-45) are equal. Substitute equation (2-44b) into the I_ν^S part of the integral term of equation (2-45)

$$\begin{aligned} \frac{\tilde{\omega}_\nu}{4\pi} \int_0^{2\pi} \int_{-1}^1 P(\mu, \phi; \mu', \phi') \pi F_0 e^{-\tau_\nu/\mu_0} \delta(\mu' - \mu_0) \delta(\phi' - \phi_0) d\mu' d\phi' \\ = \frac{\tilde{\omega}_\nu}{4\pi} \pi F_0 e^{-\tau_\nu/\mu_0} P(\mu, \phi; -\mu_0, \phi_0) \end{aligned} \quad (2-46)$$

Use equation (2-46) to write equation (2-45) in the following form, dropping the superscript D , where I_ν is now understood to be the diffuse component only

$$\begin{aligned} \mu \frac{dI_\nu(\tau_\nu, \mu, \phi)}{d\tau_\nu} &= I_\nu(\tau_\nu, \mu, \phi) - \frac{\tilde{\omega}_\nu}{4\pi} \int_0^{2\pi} \int_{-1}^1 P(\mu, \phi; \mu', \phi') I_\nu(\tau_\nu, \mu', \phi') d\mu' d\phi' \\ &\quad - \frac{\tilde{\omega}_\nu}{4} F_0 e^{-\tau_\nu/\mu_0} P(\mu, \phi; -\mu_0, \phi_0) \end{aligned} \quad (2-47)$$

Note that for the special case of isotropic scattering, $P(\mu, \phi; \mu', \phi') = 1$,

$$\begin{aligned} \mu \frac{dI_\nu(\tau_\nu, \mu, \phi)}{d\tau_\nu} &= I_\nu(\tau_\nu, \mu, \phi) - \frac{\tilde{\omega}_\nu}{4\pi} \int_0^{2\pi} \int_{-1}^1 I_\nu(\tau_\nu, \mu', \phi') d\mu' d\phi' \\ &\quad - \frac{\tilde{\omega}_\nu}{4} F_0 e^{-\tau_\nu/\mu_0} P(\mu, \phi; -\mu_0, \phi_0) \end{aligned} \quad (2-48)$$

and if in addition we assume azimuthal symmetry

$$\begin{aligned} \mu \frac{dI_\nu(\tau_\nu, \mu)}{d\tau_\nu} &= I_\nu(\tau_\nu, \mu) - \frac{\tilde{\omega}_\nu}{2} \int_{-1}^1 I_\nu(\tau_\nu, \mu') d\mu' \\ &\quad - \frac{\tilde{\omega}_\nu}{4} F_0 e^{-\tau_\nu/\mu_0} P(\mu, -\mu_0) \end{aligned} \quad (2-49)$$

The azimuthally symmetric form of equation (2-47) is

$$\begin{aligned} \mu \frac{dI_\nu(\tau_\nu, \mu)}{d\tau_\nu} &= I_\nu(\tau_\nu, \mu) - \frac{\tilde{\omega}_\nu}{2} \int_{-1}^1 P(\mu, \mu') I_\nu(\tau_\nu, \mu') d\mu' \\ &\quad - \frac{\tilde{\omega}_\nu}{4} F_0 e^{-\tau_\nu/\mu_0} P(\mu, -\mu_0) \end{aligned} \quad (2-50)$$

Substituting equation (2-42) in equation (2-50) gives

$$\begin{aligned} \mu \frac{dI_\nu(\tau_\nu, \mu)}{d\tau_\nu} &= I_\nu(\tau_\nu, \mu) - \frac{\tilde{\omega}_\nu}{2} \sum_{\ell=0}^N \tilde{\omega}_\ell P_\ell(\mu) \int_{-1}^1 P_\ell(\mu') I_\nu(\tau_\nu, \mu') d\mu' \\ &\quad - \frac{\tilde{\omega}_\nu}{4} F_0 e^{-\tau_\nu/\mu_0} \sum_{\ell=0}^N \tilde{\omega}_\ell P_\ell(\mu) P_\ell(-\mu_0) \end{aligned} \quad (2-51)$$

This equation is frequently used as the starting point for the development of the diffuse components of the two-stream and Eddington solutions to be derived in chapters 5 and 6.

Notice the obvious differences between the forms for the azimuthally independent equations, (2-41) and (2-50). The latter equation contains the solar flux exponential term while the former does not. The presence of this exponential term is a giveaway that the radiation term contains the *diffuse* component only, whereas the form of equation (2-41) includes both the direct and the diffuse components. This difference, while obvious now, is not always pointed out by authors in the open literature and, hence, a careless application of their equations may result in rather strange-looking results, especially when applying boundary conditions.

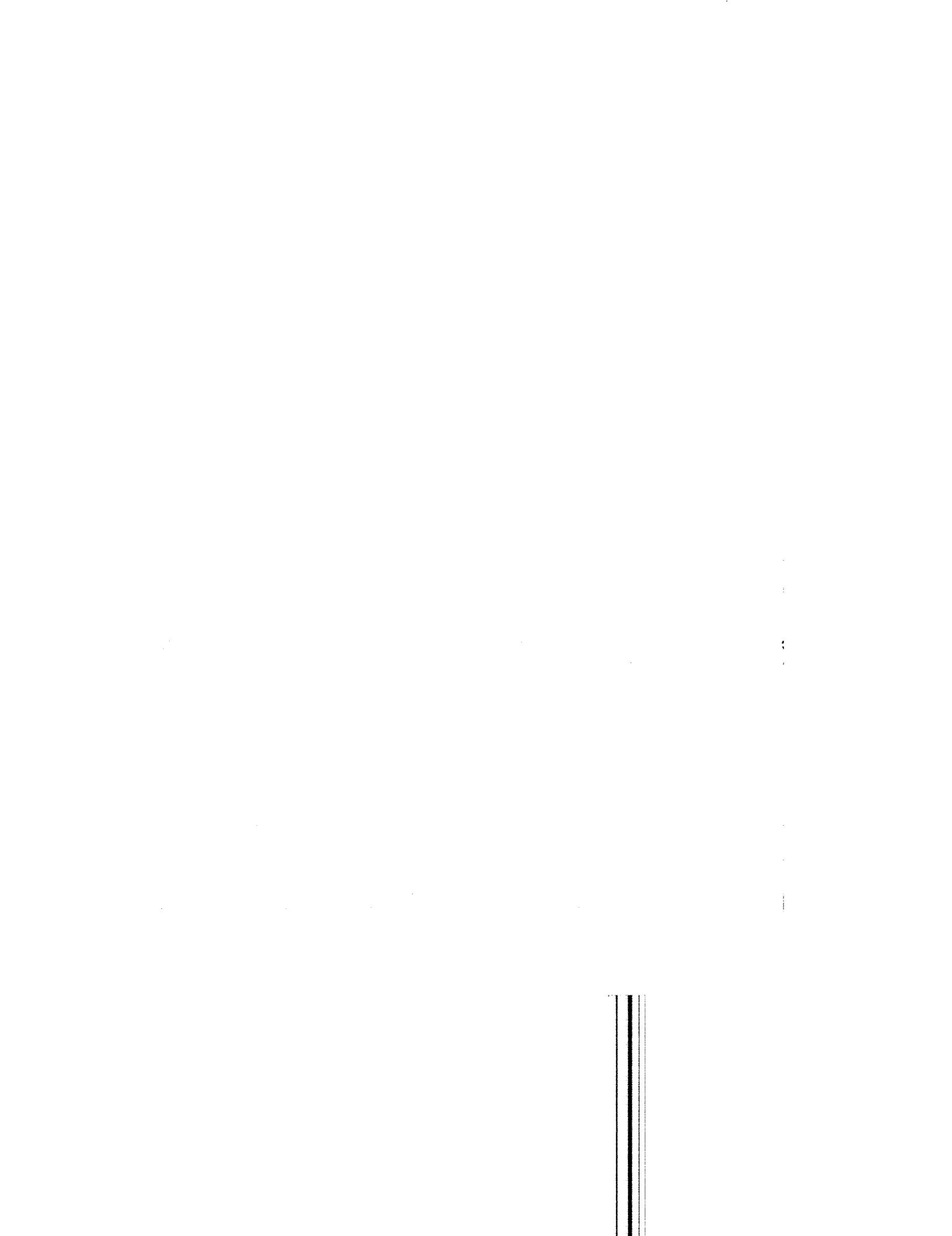

Chapter 3

Formal Solutions to the Intensity and Flux Equations

Return now to the form of the RTE in a plane-parallel atmosphere, equation (2-27)

$$\mu \frac{dI_\nu(\tau_\nu, \mu, \phi)}{d\tau_\nu} = I_\nu(\tau_\nu, \mu, \phi) - J_\nu(\tau_\nu, \mu, \phi) \quad (3-1)$$

and derive the formal solution to this equation. It should be remarked that this is not really a solution to equation (3-1) in the normal sense of being used to derive very complex numerical results. It can, in fact, be used in some very simple cases, as will be demonstrated later, but in general the coupling between the intensity and the source function precludes the formal extraction process of yielding I_ν as an explicit function of τ_ν and μ . The formal solution's utility is that it forms the starting point, either in the spectral intensity form or the flux form, both for theoretical analyses and for some elementary methods.

It is convenient to break the solution into two parts, one for the upward component

$$I_\nu^\uparrow(\tau_\nu, \mu, \phi) \quad (0 \leq \mu \leq 1)$$

and one for the downward component

$$I_\nu^\downarrow(\tau_\nu, \mu, \phi) \quad (-1 \leq \mu \leq 0)$$

with the solution subject to the boundary conditions

$$I_\nu(0, -\mu, \phi) = I_\nu^\downarrow(0, -\mu) \quad (3-2)$$

$$I_\nu(\tau_\nu^*, \mu, \phi) = I_\nu^\uparrow(\tau_\nu^*, \mu) \quad (3-3)$$

Note now that

$$\frac{d}{d\tau_\nu} \left[I_\nu(\tau_\nu, \mu, \phi) e^{-\tau_\nu/\mu} \right] = \frac{dI_\nu(\tau_\nu, \mu, \phi)}{d\tau_\nu} e^{-\tau_\nu/\mu} - \frac{1}{\mu} I_\nu(\tau_\nu, \mu, \phi) e^{-\tau_\nu/\mu}$$

so if we divide equation (3-1) by μ and multiply by $e^{-\tau_\nu/\mu}$, equation (3-1) becomes

$$\frac{d}{d\tau_\nu} \left[e^{-\tau_\nu/\mu} I_\nu(\tau_\nu, \mu, \phi) \right] = \left(-e^{-\tau_\nu/\mu} \right) \frac{J_\nu(\tau_\nu, \mu, \phi)}{\mu}$$

Let us integrate this equation between the general limits t_1 and t_2

$$e^{-t_2/\mu} I_\nu(t_2, \mu, \phi) - e^{-t_1/\mu} I_\nu(t_1, \mu, \phi) = - \int_{t_1}^{t_2} e^{-\tau'_\nu/\mu} J_\nu(\tau'_\nu, \mu, \phi) \frac{d\tau'_\nu}{\mu} \quad (3-4)$$

Now, we want to find the upward component of radiation at τ_ν . This radiation comes in part from the surface at $\tau_\nu = \tau_\nu^*$, and also from all of the infinitesimal layers of the atmosphere between τ_ν and τ_ν^* , all properly attenuated by the intervening layers of atmosphere. (See fig. 3-1.) So, in equation (3-4) we let $t_1 = \tau_\nu$ and $t_2 = \tau_\nu^*$ and solve for $I_\nu^\uparrow(\tau_\nu, \mu, \phi)$

$$I_\nu^\uparrow(\tau_\nu, \mu, \phi) = I_\nu^\uparrow(\tau_\nu^*, \mu, \phi) e^{-(\tau_\nu^* - \tau_\nu)/\mu} + \int_{\tau_\nu}^{\tau_\nu^*} e^{-(\tau'_\nu - \tau_\nu)/\mu} J_\nu(\tau'_\nu, \mu, \phi) \frac{d\tau'_\nu}{\mu} \quad (3-5)$$

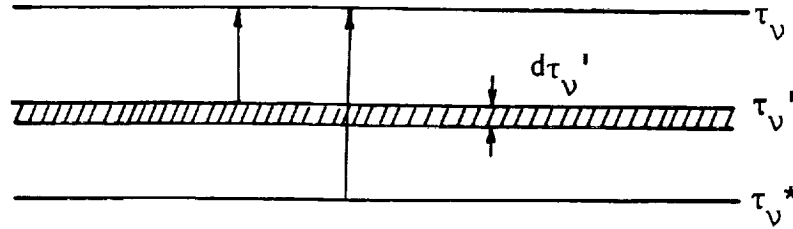

Figure 3-1. Upward radiation at τ_ν due to radiation from the surface at τ_ν^* and from intermediate layers of atmosphere at τ_ν' .

Similarly, the downward component of intensity at τ_ν is equal to the downward intensity impinging on the upper boundary at $\tau_\nu = 0$ plus all the source terms between the top layer and τ_ν , also attenuated by

the atmosphere. (See fig. 3-2.) Thus, in equation (3-4) we let $t_1 = 0$ and $t_2 = \tau_\nu$ and solve for $I_\nu^\downarrow(\tau_\nu, \mu, \phi)$

$$I_\nu^\downarrow(\tau_\nu, \mu, \phi) = I_\nu^\downarrow(0, \mu, \phi)e^{\tau_\nu/\mu} - \int_0^{\tau_\nu} e^{-(\tau'_\nu - \tau_\nu)/\mu} J_\nu(\tau'_\nu, \mu, \phi) \frac{d\tau'_\nu}{\mu} \quad (3-6)$$

in which $-1 \leq \mu \leq 0$.

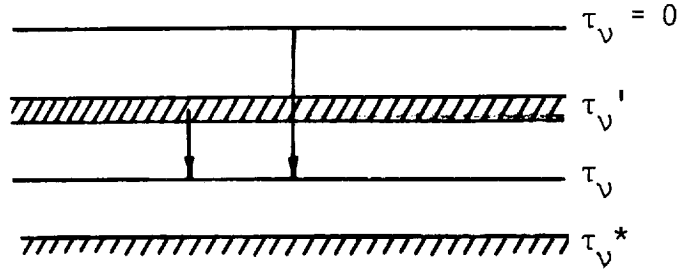

Figure 3-2. Downward radiation at τ_ν due to radiation impinging on the top surface $\tau_\nu = 0$ and the intermediate layers of atmosphere at τ'_ν .

Equations (3-5) and (3-6) demonstrate the usual exponential nature of the attenuation of monochromatic radiation with increasing optical depth. This requires, of course, a negative argument in the exponential, while equation (3-6) appears to produce a positive argument. However, μ is negative, thus giving the proper sign. So in order to make the equation *look* right, most atmospheric physicists at this point replace the μ with $-\mu$ and incorporate the minus sign explicitly in the exponential term of equation (3-6). This convention tends to complicate the interpretation of the ensuing equations to some degree, but as it is a relatively minor nuisance, and is consistently done in the literature, it will be followed here also, with appropriate caveats as the need arises. Then equation (3-6) becomes

$$I_\nu^\downarrow(\tau_\nu, -\mu, \phi) = I_\nu^\downarrow(0, -\mu, \phi)e^{-\tau_\nu/\mu} + \int_0^{\tau_\nu} e^{-(\tau_\nu - \tau'_\nu)/\mu} J_\nu(\tau'_\nu, -\mu, \phi) \frac{d\tau'_\nu}{\mu} \quad (3-7)$$

Equation (3-7) is the desired equation for the downward component of spectral intensity.

To get the flux components, we proceed from equation (2-39)

$$F_{\nu}(\tau_{\nu}) = \int_0^{2\pi} \int_{-1}^1 \mu I_{\nu}(\tau_{\nu}, \mu, \phi) d\mu d\phi \quad (3-8)$$

which we break into components as

$$F_{\nu}(\tau_{\nu}) = \int_0^{2\pi} d\phi \left[\int_{-1}^0 \mu I_{\nu}^{\downarrow}(\tau_{\nu}, \mu, \phi) d\mu + \int_0^1 \mu I_{\nu}^{\uparrow}(\tau_{\nu}, \mu, \phi) d\mu \right] \quad (3-9)$$

At this point we must be wary in the literature. If the convention $-1 \leq \mu \leq +1$ for μ is adhered to, then equation (3-9) can be continued directly as

$$F_{\nu}(\tau_{\nu}) = F_{\nu}^{\uparrow}(\tau_{\nu}) + F_{\nu}^{\downarrow}(\tau_{\nu}) \quad (3-10)$$

with

$$F_{\nu}^{\uparrow}(\tau_{\nu}) = \int_0^{2\pi} \int_0^1 \mu I_{\nu}^{\uparrow}(\tau_{\nu}, \mu, \phi) d\mu d\phi \quad (3-11)$$

and

$$F_{\nu}^{\downarrow}(\tau_{\nu}) = \int_0^{2\pi} \int_{-1}^0 \mu I_{\nu}^{\downarrow}(\tau_{\nu}, \mu, \phi) d\mu d\phi \quad (3-12)$$

But if the convention $0 \leq \mu \leq +1$ for μ is followed, and we replace μ with $-\mu$ for the downward component, then we proceed from equation (3-9) as

$$\begin{aligned} F_{\nu}(\tau_{\nu}) &= \int_0^{2\pi} \int_0^1 \mu I_{\nu}^{\uparrow}(\tau_{\nu}, \mu, \phi) d\mu d\phi + \int_0^{2\pi} \int_{-1}^0 \mu I_{\nu}^{\downarrow}(\tau_{\nu}, \mu, \phi) d\mu d\phi \\ &= \int_0^{2\pi} \int_0^1 \mu I_{\nu}^{\uparrow}(\tau_{\nu}, \mu, \phi) d\mu d\phi - \int_0^{2\pi} \int_0^{-1} \mu I_{\nu}^{\downarrow}(\tau_{\nu}, \mu, \phi) d\mu d\phi \\ &= \int_0^{2\pi} \int_0^1 \mu I_{\nu}^{\uparrow}(\tau_{\nu}, \mu, \phi) d\mu d\phi - \int_0^{2\pi} \int_0^1 \mu I_{\nu}^{\downarrow}(\tau_{\nu}, -\mu, \phi) d\mu d\phi \\ &= F_{\nu}^{\uparrow}(\tau_{\nu}) - F_{\nu}^{\downarrow}(\tau_{\nu}) \end{aligned} \quad (3-13)$$

where

$$F_{\nu}^{\uparrow}(\tau_{\nu}) = \int_0^{2\pi} \int_0^1 \mu I_{\nu}^{\uparrow}(\tau_{\nu}, \mu, \phi) d\mu d\phi \quad (3-14)$$

and

$$F_{\nu}^{\downarrow}(\tau_{\nu}) = \int_0^{2\pi} \int_0^1 \mu I_{\nu}^{\downarrow}(\tau_{\nu}, -\mu, \phi) d\mu d\phi \quad (3-15)$$

Note the difference in signs and the difference in the integration limits between equations (3-10) and (3-13). $F_{\nu}^{\uparrow}(\tau_{\nu})$ is evaluated in the same way in both cases, but $F_{\nu}^{\downarrow}(\tau_{\nu})$ is handled somewhat differently. So, we will develop $F_{\nu}^{\uparrow}(\tau_{\nu})$ first, and then develop both expressions for $F_{\nu}^{\downarrow}(\tau_{\nu})$.

$F_{\nu}^{\uparrow}(\tau_{\nu})$ is given by either equation (3-11) or equation (3-14), using $I_{\nu}(\tau_{\nu}, \mu, \phi)$ from equation (3-5)

$$F_{\nu}^{\uparrow}(\tau_{\nu}) = \int_0^{2\pi} \int_0^1 \mu I_{\nu}^{\uparrow}(\tau_{\nu}^*, \mu, \phi) e^{-(\tau_{\nu}^* - \tau_{\nu})/\mu} d\mu d\phi \\ + \int_0^{2\pi} \int_0^1 \mu \int_{\tau_{\nu}}^{\tau_{\nu}^*} e^{-(\tau'_{\nu} - \tau_{\nu})/\mu} J_{\nu}(\tau'_{\nu}, \mu, \phi) \frac{d\tau'_{\nu}}{\mu} d\mu d\phi \quad (3-16)$$

This is about as far as we can go analytically with equation (3-16) without having any knowledge about either the directional distribution of the radiance or the source function. We can proceed with this development if we make the *assumption* that the phase function, and hence the source function, are *isotropic*. This is a rather limiting restriction, and applies only to the case where the source function can be replaced by the Planck function, as in equation (2-30). This then becomes a problem of emission and not scattering. The resulting equations are not applicable to general scattering problems, but *are* applicable to studies of infrared radiation. These forms are frequently seen in the literature, and it was thought not unreasonable to present them here, even though the main thrust of these notes is with the scattering problem.

In any event, we make the above assumption and write equation (3-16) as

$$F_{\nu}^{\uparrow}(\tau_{\nu}) = 2\pi I_{\nu}^{\uparrow}(\tau_{\nu}^*) \int_0^1 e^{-(\tau_{\nu}^* - \tau_{\nu})/\mu} \mu d\mu \\ + 2\pi \int_{\tau_{\nu}}^{\tau_{\nu}^*} J_{\nu}(\tau'_{\nu}) d\tau'_{\nu} \int_0^1 e^{-(\tau'_{\nu} - \tau_{\nu})/\mu} d\mu \quad (3-17)$$

The μ -integrals are exponential integrals of various orders, where

$$E_n(x) \equiv \int_1^{\infty} \frac{e^{-xt}}{t^n} dt \quad (3-18)$$

Evaluation of the first integral:

Let

$$\mu = \frac{1}{\xi} \quad d\mu = -\frac{d\xi}{\xi^2}$$

then

$$\begin{aligned} \int_0^1 \mu e^{-(\tau_\nu^* - \tau_\nu)/\mu} d\mu &= - \int_\infty^1 \frac{1}{\xi} e^{-(\tau_\nu^* - \tau_\nu)\xi} \frac{d\xi}{\xi^2} \\ &= \int_1^\infty \frac{e^{-(\tau_\nu^* - \tau_\nu)\xi}}{\xi^3} d\xi = E_3(\tau_\nu^* - \tau_\nu) \end{aligned}$$

Evaluation of the second integral:

Let

$$\begin{aligned} \int_0^1 e^{-(\tau_\nu' - \tau_\nu)/\mu} d\mu &= - \int_\infty^1 e^{-(\tau_\nu' - \tau_\nu)\xi} \frac{d\xi}{\xi^2} \\ &= \int_1^\infty \frac{e^{-(\tau_\nu' - \tau_\nu)\xi}}{\xi^2} d\xi = E_2(\tau_\nu' - \tau_\nu) \end{aligned}$$

so that we can write:

$$F_\nu^\dagger(\tau_\nu) = 2\pi I_\nu^\dagger \tau_\nu^* E_3(\tau_\nu^* - \tau_\nu) + 2\pi \int_{\tau_\nu}^{\tau_\nu^*} E_2(\tau_\nu' - \tau_\nu) J_\nu(\tau_\nu') d\tau_\nu' \quad (3-19)$$

This equation could stand as it is, but it is more convenient to put it into another form—from equation (3-18)

$$\frac{dE_n(x)}{dx} = \int_1^\infty -t \frac{e^{-xt}}{t^n} dt = - \int_1^\infty \frac{e^{-xt}}{t^{n-1}} dt = -E_{n-1}(x)$$

Thus

$$\frac{dE_3(\tau_\nu' - \tau_\nu)}{d\tau_\nu'} = \left[\frac{dE_3(\tau_\nu' - \tau_\nu)}{d(\tau_\nu' - \tau_\nu)} \right] \left[\frac{d(\tau_\nu' - \tau_\nu)}{d\tau_\nu'} \right] = -E_2(\tau_\nu' - \tau_\nu)$$

so that we can write equation (3-19) as

$$\begin{aligned} F_\nu^\dagger(\tau_\nu) &= 2\pi I_\nu^\dagger(\tau_\nu^*) E_3(\tau_\nu^* - \tau_\nu) \\ &\quad - 2\pi \int_{\tau_\nu}^{\tau_\nu^*} J_\nu(\tau_\nu') \frac{dE_3(\tau_\nu' - \tau_\nu)}{d\tau_\nu'} d\tau_\nu' \end{aligned} \quad (3-20)$$

Integrate by parts and write equation (3-20) in the form

$$F_{\nu}^{\uparrow}(\tau_{\nu}) = 2\pi E_3(\tau_{\nu}^* - \tau_{\nu}) \left[I_{\nu}^{\uparrow}(\tau_{\nu}^*) - J_{\nu}(\tau_{\nu}^*) \right] + 2\pi J_{\nu}(\tau_{\nu}) \\ + 2\pi \int_{\tau_{\nu}}^{\tau_{\nu}^*} E_3(\tau'_{\nu} - \tau_{\nu}) \frac{dJ_{\nu}(\tau'_{\nu})}{d\tau'_{\nu}} d\tau'_{\nu} \quad (3-21)$$

The reason for bringing in the E_3 in the second integral rather than leaving the form as E_2 is that, as we will see later in equation (4-26), $2E_3(\tau_{\nu})$ is an angular integrated monochromatic transmission function, $\tilde{T}_r(\tau_{\nu})$, which, when integrated over frequency, can in some cases easily be evaluated from band transmission models. Guided by this concept then, we write equation (3-21) in final form as

$$F_{\nu}^{\uparrow}(\tau_{\nu}) = \pi \tilde{T}_r(\tau_{\nu}^* - \tau_{\nu}) \left[I_{\nu}^{\uparrow}(\tau_{\nu}^*) - J_{\nu}(\tau_{\nu}^*) \right] + 2\pi J_{\nu}(\tau_{\nu}) \\ + \pi \int_{\tau_{\nu}}^{\tau_{\nu}^*} \tilde{T}_r(\tau'_{\nu} - \tau_{\nu}) \frac{dJ_{\nu}(\tau'_{\nu})}{d\tau'_{\nu}} d\tau'_{\nu} \quad (3-22)$$

Note the physical difference between the two terms in the bracket:

$$\begin{aligned} \pi I_{\nu}^{\uparrow}(\tau_{\nu}^*) &= \text{flux from the surface at } \tau_{\nu} = \tau_{\nu}^* \\ \pi J_{\nu}(\tau_{\nu}^*) &= \text{source flux from the atmosphere immediately} \\ &\quad \text{above the surface at } \tau_{\nu} = \tau_{\nu}^* \end{aligned}$$

Now we evaluate the downward flux components. This is done exactly as above for $F_{\nu}^{\uparrow}(\tau_{\nu})$, except that there are some mildly tricky steps involved in the manipulation of the E -integrals that can easily give wrong signs if one is not very careful.

First, we will evaluate equation (3-12). Then we *must* use the $I_{\nu}^{\downarrow}(\tau_{\nu})$ defined by equation (3-6)

$$F_{\nu}^{\downarrow}(\tau_{\nu}) = \int_0^{2\pi} \int_{-1}^0 \mu \left[I_{\nu}^{\downarrow}(0, \mu, \phi) e^{\tau_{\nu}/\mu} - \int_0^{\tau_{\nu}} e^{-(\tau'_{\nu} - \tau_{\nu})/\mu} J_{\nu}(\tau'_{\nu}, \mu, \phi) \frac{d\tau'_{\nu}}{\mu} \right] d\mu d\phi \quad (3-23)$$

and if we make the isotropic assumption on I_{ν} and J_{ν} this reduces to

$$F_{\nu}^{\downarrow}(\tau_{\nu}) = 2\pi I_{\nu}^{\downarrow}(0) \int_{-1}^0 \mu e^{\tau_{\nu}/\mu} d\mu - 2\pi \int_0^{\tau_{\nu}} J_{\nu}(\tau'_{\nu}) d\tau'_{\nu} \int_{-1}^0 e^{-(\tau'_{\nu} - \tau_{\nu})/\mu} d\mu \quad (3-24)$$

Evaluate the first integral:

$$\int_{-1}^0 \mu e^{\tau\nu/\mu} d\mu$$

Let

$$\mu = -\frac{1}{\xi} \quad d\mu = \frac{d\xi}{\xi^2}$$

$$\int_{-1}^0 \mu e^{\tau\nu/\mu} d\mu = \int_1^{\infty} \left(-\frac{1}{\xi}\right) e^{-\tau\nu\xi} \frac{d\xi}{\xi^2} = -E_3(\tau\nu)$$

Evaluate the μ -dependent part of the second integral:

$$\int_{-1}^0 e^{-(\tau'_\nu - \tau\nu)/\mu} d\mu = \int_1^{\infty} e^{(\tau'_\nu - \tau\nu)\xi} \frac{d\xi}{\xi^2} = \int_1^{\infty} \frac{e^{-(\tau\nu - \tau'_\nu)\xi}}{\xi^2} d\xi = E_2(\tau\nu - \tau'_\nu)$$

Again convert E_2 to an E_3 derivative:

$$\frac{dE_3(\tau\nu - \tau'_\nu)}{d\tau'_\nu} = \frac{dE_3(\tau\nu - \tau'_\nu)}{d(\tau\nu - \tau'_\nu)} \frac{d(\tau\nu - \tau'_\nu)}{d\tau'_\nu} = E_2(\tau\nu - \tau'_\nu)$$

Hence, equation (3-24) becomes

$$F_\nu^\downarrow(\tau\nu) = -2\pi I_\nu^\downarrow(0)E_3(\tau\nu) - 2\pi \int_0^{\tau\nu} J_\nu(\tau'_\nu) \frac{dE_3(\tau\nu - \tau'_\nu)}{d\tau'_\nu} d\tau'_\nu \quad (3-25)$$

Integrate by parts and write equation (3-25) as

$$F_\nu^\downarrow(\tau\nu) = -2\pi I_\nu^\downarrow(\tau\nu)E_3(\tau\nu) - 2\pi J_\nu(\tau\nu) + 2\pi J_\nu(0)E_3(\tau\nu) \\ + 2\pi \int_0^{\tau\nu} E_3(\tau\nu - \tau'_\nu) \frac{dJ_\nu(\tau'_\nu)}{d\tau'_\nu} d\tau'_\nu \quad (3-26)$$

or, in terms of the transmission function

$$F_\nu^\downarrow(\tau\nu) = -\pi \tilde{T}_r(\tau\nu) \left[I_\nu^\downarrow(0) - J_\nu(0) \right] - 2\pi J_\nu(\tau\nu) \\ + \pi \int_0^{\tau\nu} \tilde{T}_r(\tau\nu - \tau'_\nu) \frac{dJ_\nu(\tau'_\nu)}{d\tau'_\nu} d\tau'_\nu \quad (3-27)$$

The net flux follows from equation (3-10), using equations (3-22) and (3-27)

$$\begin{aligned}
 F_{\nu}(\tau_{\nu}) &= \pi \tilde{T}_r(\tau_{\nu}^* - \tau_{\nu}) \left[I_{\nu}^{\uparrow}(\tau_{\nu}^*) - J_{\nu}(\tau_{\nu}^*) \right] \\
 &\quad - \pi \tilde{T}_r(\tau_{\nu}) \left[I_{\nu}^{\downarrow}(0) - J_{\nu}(0) \right] + \pi \int_0^{\tau_{\nu}} \tilde{T}_r(\tau_{\nu} - \tau'_{\nu}) \frac{dJ_{\nu}(\tau'_{\nu})}{d\tau'_{\nu}} d\tau'_{\nu} \\
 &\quad + \pi \int_{\tau_{\nu}}^{\tau_{\nu}^*} \tilde{T}_r(\tau'_{\nu} - \tau_{\nu}) \frac{dJ_{\nu}(\tau'_{\nu})}{d\tau'_{\nu}} d\tau'_{\nu}
 \end{aligned}$$

Now, $\tilde{T}_r(\tau_{\nu} - \tau'_{\nu}) = T_r(\tau'_{\nu} - \tau_{\nu})$, since these are transmission functions between the optical depths τ_{ν} and τ'_{ν} , and are assumed to be the same numerical value when taken in either direction. Thus, we get

$$\begin{aligned}
 F_{\nu}(\tau_{\nu}) &= \pi \tilde{T}_r(\tau_{\nu}^* - \tau_{\nu}) \left[I_{\nu}^{\uparrow}(\tau_{\nu}^*) - J_{\nu}(\tau_{\nu}^*) \right] \\
 &\quad - \pi \tilde{T}_r(\tau_{\nu}) \left[I_{\nu}^{\downarrow}(0) - J_{\nu}(0) \right] \\
 &\quad + \pi \int_0^{\tau_{\nu}^*} \tilde{T}_r(\tau_{\nu} - \tau'_{\nu}) \frac{dJ_{\nu}(\tau'_{\nu})}{d\tau'_{\nu}} d\tau'_{\nu} \quad (3-28)
 \end{aligned}$$

This equation for the net flux forms the starting point for many studies of the temperature structure of the Earth's atmosphere, and is used to describe the infrared cooling part of this structure. See, for example, Rodgers and Walshaw (1966).

Now, we develop $F_{\nu}^{\downarrow}(\tau_{\nu})$ from equation (3-15), where in this case we must use equation (3-7) to define $I_{\nu}^{\downarrow}(\tau_{\nu}, -\mu, \phi)$

$$\begin{aligned}
 F_{\nu}^{\downarrow}(\tau_{\nu}) &= \int_0^{2\pi} \int_0^1 \mu \left[I_{\nu}^{\downarrow}(0) e^{-\tau_{\nu}/\mu} d\mu + \int_0^{\tau_{\nu}} e^{-(\tau_{\nu}-\tau'_{\nu})/\mu} J_{\nu}(\tau'_{\nu}, -\mu, \phi) \frac{d\tau'_{\nu}}{\mu} \right] d\mu d\phi \\
 &= 2\pi I_{\nu}^{\downarrow}(0) \int_0^1 \mu e^{-\tau_{\nu}/\mu} d\mu + 2\pi \int_0^{\tau_{\nu}} J_{\nu}(\tau'_{\nu}) d\tau'_{\nu} \int_0^1 e^{-(\tau_{\nu}-\tau'_{\nu})/\mu} d\mu \quad (3-29)
 \end{aligned}$$

Evaluate the first integral:

$$\mu = -1/\xi$$

$$\int_0^1 \mu e^{-\tau_{\nu}/\mu} d\mu = E_3(\tau_{\nu})$$

Evaluate the μ -dependent part of the second integral:

$$\int_0^1 e^{-(\tau_\nu - \tau'_\nu)/\mu} d\mu = E_2(\tau_\nu - \tau'_\nu)$$

so that equation (3-29) becomes

$$F_\nu^\downarrow(\tau_\nu) = 2\pi I_\nu^\downarrow(0)E_3(\tau_\nu) + 2\pi \int_0^{\tau_\nu} J_\nu(\tau'_\nu) \frac{dE_3(\tau_\nu - \tau'_\nu)}{d\tau'_\nu} d\tau'_\nu \quad (3-30)$$

Integrate by parts and equation (3-30) becomes

$$\begin{aligned} F_\nu^\downarrow(\tau_\nu) &= 2\pi E_3(\tau_\nu) \left[I_\nu^\downarrow(0) - J_\nu(0) \right] + 2\pi J_\nu(\tau_\nu) \\ &\quad - 2\pi \int_0^{\tau_\nu} E_3(\tau_\nu - \tau'_\nu) \frac{dJ_\nu(\tau'_\nu)}{d\tau'_\nu} d\tau'_\nu \end{aligned} \quad (3-31)$$

or

$$\begin{aligned} F_\nu^\downarrow(\tau_\nu) &= \pi \tilde{T}_r(\tau_\nu) \left[I_\nu^\downarrow(0) - J_\nu(0) \right] + 2\pi J_\nu(\tau_\nu) \\ &\quad - \pi \int_0^{\tau_\nu} \tilde{T}_r(\tau_\nu - \tau'_\nu) \frac{dJ_\nu(\tau'_\nu)}{d\tau'_\nu} d\tau'_\nu \end{aligned} \quad (3-32)$$

It can be seen that equation (3-32) is exactly the negative of equation (3-27)—which is extremely fortunate or we would have a serious problem in computing the net flux—and hence, the net flux, given now by equation (3-13), also produces equation (3-28).

The message here is that, when reading the literature, one's attention must be drawn to the way the author defines the downward flux; i.e., whether with $-1 \leq \mu \leq 0$ or with $0 \leq \mu \leq +1$, and, hence, whether the net flux is defined by equation (3-10) or equation (3-13).

Chapter 4

Reflection and Transmission Coefficients, Surface Effects, and Albedo

In many applications of radiative transfer theory, we are not particularly interested in what goes on in the interior of the atmosphere, or inside a finite thickness of the atmosphere. For instance, we may be interested only in what comes out of the top of the atmosphere at $\tau_\nu = 0$, or what comes out of the bottom at $\tau_\nu = \tau_\nu^*$. In order to simplify the extraction of these data from the radiation field, a theoretical approach known as the *principle of invariance* was developed by Ambartsumyan (1958), and further developed and clarified by Chandrasekhar (1960).

We mention this principle here in order to provide a springboard for introducing the concepts of *reflection* and *transmission* functions, to which this chapter is devoted. The principle of invariance will be discussed in detail in chapter 8. For now, we merely state that if the reflection and transmission properties of two thin slabs of optical material are known, then the principle allows us to determine the overall reflection and transmission properties of a composite slab made by placing the two thin slabs face to face. The solution to the radiative transfer equation for a thin slab is relatively simple (see chap. 5). Thus, when working with atmospheric problems we could divide the atmosphere into a number of thin layers, use the thin-layer solutions for the RTE to determine the transmission and reflection properties of the thin layers, and then use the principle of invariance to build up the atmosphere layer by layer, and thus compute the reflection and transmission properties for the finite-thickness atmosphere without having to solve the complete form of the RTE. This is a particularly useful concept in deriving numerical results for both homogeneous and nonhomogeneous atmospheres.

We proceed now with the introduction of the transmission and reflection functions.

Chandrasekhar defines the *scattering* function,

$$S(\tau^* : \mu, \phi, \mu_0, \phi_0)$$

and the *transmission* function

$$\tilde{T}(\tau^* : \mu, \phi, \mu_0, \phi_0)$$

by the following equations

$$I_{\text{REF}}(0, \mu, \phi) = \frac{1}{4\pi\mu} \int_0^{2\pi} \int_0^1 S(\tau^* : \mu, \phi, \mu', \phi') I_{\text{INC}}(\mu', \phi') d\mu' d\phi' \quad (4-1)$$

$$I_{\text{TRANS}}(\tau^*, -\mu, \phi) = \frac{1}{4\pi\mu} \int_0^{2\pi} \int_0^1 \tilde{T}(\tau^* : \mu, \phi, \mu', \phi') I_{\text{INC}}(\mu', \phi') d\mu' d\phi' \quad (4-2)$$

where I_{REF} is the reflected diffuse radiation, I_{TRANS} is the transmitted diffuse radiation, and I_{INC} is the incident radiation. Both S and \tilde{T} are explicit functions of the total optical depth, τ_v^* . The factor $1/\mu$ was introduced to secure the symmetry of S and \tilde{T} in the pairs of variables (μ, ϕ) and (μ_0, ϕ_0) ; i.e.,

$$\begin{aligned} S(\tau^* : \mu, \phi, \mu_0, \phi_0) &= S(\tau^* : \mu_0, \phi_0, \mu, \phi) \\ \tilde{T}(\tau^* : \mu, \phi, \mu_0, \phi_0) &= \tilde{T}(\tau^* : \mu_0, \phi_0, \mu, \phi) \end{aligned}$$

If the incident radiation is considered to be solar radiation, entering the atmosphere in a parallel, or collimated, beam, then we can write (see eqs. (2-44))

$$I_{\text{INC}}(\mu', \phi') = \pi F_0 \delta(\mu' - \mu_0) \delta(\phi' - \phi_0) \quad (4-3)$$

where πF_0 is the solar flux, and the δ are Dirac delta functions. Substitution of equation (4-3) into equations (4-1) and (4-2) gives, for a collimated incident beam,

$$I_{\text{REF}}(0, \mu, \phi) = \frac{F_0}{4\mu} S(\tau^* : \mu, \phi, \mu_0, \phi_0) \quad (4-4)$$

$$I_{\text{TRANS}}(\tau^*, -\mu, \phi) = \frac{F_0}{4\mu} \tilde{T}(\tau^* : \mu, \phi, \mu_0, \phi_0) \quad (4-5)$$

Note that \tilde{T} defines the *diffuse* component of the transmission only. The reduced direct component, $\pi F_0 e^{-\tau/\mu_0}$, is not included in \tilde{T} .

There is another set of definitions of reflection and transmission coefficients which appears frequently in the literature (e.g., Liou, 1980),

which is defined by the relations

$$I_{\text{REF}}(0, \mu, \phi) = \frac{1}{\pi} \int_0^{2\pi} \int_0^1 R(\mu, \phi : \mu', \phi') I_{\text{INC}}(-\mu', \phi') \mu' d\mu' d\phi' \quad (4-6)$$

$$I_{\text{TRANS}}(\tau^*, -\mu, \phi) = \frac{1}{\pi} \int_0^{2\pi} \int_0^1 T(\mu, \phi : \mu', \phi') I_{\text{INC}}(-\mu', \phi') \mu' d\mu' d\phi' \quad (4-7)$$

Note that these differ from S and \tilde{T} in that they drop the $1/\mu$ in front of the integrals, but include a μ under the integral. Thus, the integrals in equations (4-6) and (4-7) are closely related to flux integrals. This is the reason for the $1/\pi$ factor, changing the integral from flux to radiance, as required by the left-hand side.

If we again use equation (4-3) for the incoming flux, we get

$$I_{\text{REF}}(0, \mu, \phi) = \mu_0 F_0 R(\mu, \phi : \mu_0, \phi_0) \quad (4-8)$$

$$I_{\text{TRANS}}(\tau^*, -\mu, \phi) = \mu_0 F_0 T(\mu, \phi : \mu_0, \phi_0) \quad (4-9)$$

Comparison of equations (4-4) and (4-5) with equations (4-8) and (4-9) gives the correspondences between the two sets of coefficients

$$R = \frac{S}{4\mu_0\mu} \quad (4-10)$$

$$T = \frac{\tilde{T}}{4\mu_0\mu} \quad (4-11)$$

Frankly, it is not at all obvious which set, if either, is better to use— R and T , or S and \tilde{T} . There seem to be some small practical advantages in using R and T , since they are defined in terms of fluxes rather than radiances, and since the albedos are generally also defined in terms of flux quantities. The set S and \tilde{T} seems to be used more frequently in high-powered theoretical developments than does the set R and T , but this may be due more to the impetus given these parameters by Chandrasekhar's studies and influence than to any inherent advantage of their own.

From the definitions of equations (4-6) and (4-7) we can immediately write expressions for the diffusely reflected flux and the diffusely transmitted flux

$$F_{\text{REF}}(0, \mu, \phi) = \int_0^{2\pi} \int_0^1 R(\mu, \phi : \mu', \phi') I_{\text{INC}}(-\mu', \phi') \mu' d\mu' d\phi' \quad (4-12)$$

$$F_{\text{TRANS}}(\tau^*, -\mu, \phi) = \int_0^{2\pi} \int_0^1 T(\mu, \phi : \mu', \phi') I_{\text{INC}}(-\mu', \phi') \mu' d\mu' d\phi' \quad (4-13)$$

We define the *planetary* or *local albedo* as the ratio of the total outgoing flux at the top of the atmosphere to the total flux entering the atmosphere at the angles θ_0 and ϕ_0 . The total incoming flux is

$$F_{\text{INC}} = \int_0^{2\pi} \int_0^1 I_{\text{INC}}(-\mu', \phi') \mu' d\mu' d\phi'$$

and for the collimated beam of equation (4-3)

$$F_{\text{INC}} = \pi F_0 \mu_0 \quad (4-14)$$

The total outgoing flux is found by integrating equation (4-8) over all angles μ and ϕ :

$$F_{\text{REF}} = \mu_0 F_0 \int_0^{2\pi} \int_0^1 \mu R(\mu, \phi : \mu_0, \phi_0) d\mu d\phi \quad (4-15)$$

and hence, the planetary albedo, $r(\mu_0)$, is given by

$$r(\mu_0) = \frac{F_{\text{REF}}(0, \mu, \phi)}{F_{\text{INC}}} = \frac{1}{\pi} \int_0^{2\pi} \int_0^1 R(\mu, \phi : \mu_0, \phi_0) \mu d\mu d\phi \quad (4-17)$$

Similarly, the diffuse transmission function, $t(\mu_0)$, is written

$$t(\mu_0) = \frac{F_{\text{TRANS}}(\tau^*, -\mu, \phi)}{F_{\text{INC}}} \quad (4-18)$$

$$= \frac{1}{\pi} \int_0^{2\pi} \int_0^1 T(\mu, \phi : \mu_0, \phi_0) \mu d\mu d\phi \quad (4-19)$$

Again, for emphasis, equation (4-19) describes the *diffuse* transmission function only. The direct transmission function is given by $e^{-\tau^*/\mu_0}$. However, the more fundamental definition in equation (4-18) may include both transmission components.

For the special case of azimuthal symmetry, equations (4-17) and (4-19) reduce to

$$r(\mu_0) = 2 \int_0^1 R(\mu, \mu_0) \mu d\mu \quad (4-20)$$

and

$$t(\mu_0) = 2 \int_0^1 T(\mu, \mu_0) \mu \, d\mu \quad (4-21)$$

respectively.

The *spherical albedo* is defined for a planetary atmosphere as the ratio of the total flux reflected at all angles by the planet to the total flux incident on the planet. If we let the radius of the planet be a , the total flux incident on it is

$$(\pi F_0)(\pi a^2) \quad (4-22)$$

We want to find the total flux reflected by the planet. Let dA be the area of the elemental ring on the surface of the planet as shown in figure 4-1.

$$dA = 2\pi a^2 \sin \theta_0 \, d\theta_0$$

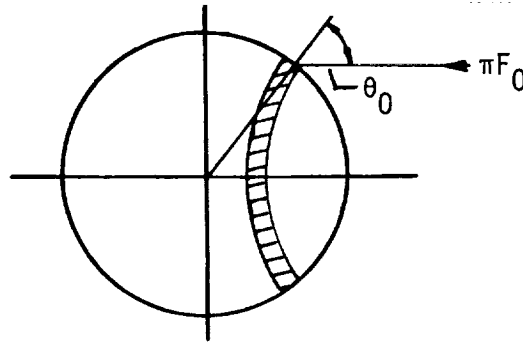

Figure 4-1. Sketch of the geometry involved in computing the spherical albedo.

The elemental area *normal* to the incoming rays is

$$dA \cos \theta_0 = 2\pi a^2 \sin \theta_0 \cos \theta_0 \, d\theta_0$$

or, with $\mu_0 = \cos \theta_0$

$$\mu_0 \, dA = -2a^2 \mu_0 \, d\mu_0$$

Thus, the total flux reflected by the element dA is

$$(-2\pi a^2 \mu_0 \, d\mu_0) [\pi F_0 r(\mu_0)]$$

and integrating over μ_0 from 1 to 0

$$F_{\text{REF}} = (2\pi a^2)\pi F_0 \int_0^1 \mu_0 \tau(\mu_0) d\mu_0 \quad (4-23)$$

The spherical albedo, $\bar{\tau}$, then becomes

$$\begin{aligned} \bar{\tau} &= \frac{(2\pi a^2)\pi F_0 \int_0^1 \mu_0 \tau(\mu_0) d\mu_0}{\pi a^2 \cdot \pi F_0} \\ \bar{\tau} &= 2 \int_0^1 \mu_0 \tau(\mu_0) d\mu_0 \end{aligned} \quad (4-24)$$

In a similar manner we can define a spherical transmission function

$$\bar{t} = 2 \int_0^1 \mu_0 t(\mu_0) d\mu_0 \quad (4-25)$$

The spherical transmission function for the *direct* component is

$$\bar{t}_0 = 2 \int_0^1 \mu_0 e^{-\tau^*/\mu_0} d\mu_0 = 2E_3(\tau^*) \quad (4-26)$$

(See eq. (3-18).) We see that E_3 is related to the direct transmission and that this is the reason for changing from E_2 to E_3 in the development of the flux equations in the last chapter.

Inclusion of Surface Effects

The reflection functions and albedos we have derived so far are for the atmosphere alone. If the atmosphere is bounded below by a reflecting surface, as it obviously is, then the reflection function and the albedo of the total system must be modified somehow by the presence of the surface. We now consider this problem, and use the approach of Tanré (1982). This approach permits us to work the atmospheric problem alone, without considering the surface effects, and then add the surface effects separately. Thus, the optically thin atmosphere and the single-scattering solutions introduced in the next chapter acquire considerable importance.

Consider an atmosphere of optical depth τ^* bounded below by a Lambertian surface; i.e., a surface which reflects equally in all directions. Assume that each point of the surface is Lambertian with a reflectance ρ_s , and that each part of the surface receives the same downward flux. The solar flux at the top of the atmosphere is, as

usual, denoted by πF_0 , and it enters the atmosphere at the angles μ_0 and ϕ_0 . The total flux received by each surface element is the sum of three separate components (as shown in fig. (4-2):

1. A direct flux component—the incoming solar flux attenuated along the slant path,

$$\pi \mu_0 F_0 e^{-\tau^*/\mu_0} \quad (4-27)$$

2. A diffuse transmission component, arriving at the surface after multiple scattering (see eq. (4-19))

$$\pi \mu_0 F_0 t(-\mu_0) \quad (4-28)$$

3. A diffuse component arriving at the surface after multiple scatterings and reflections between the atmosphere and the surface.

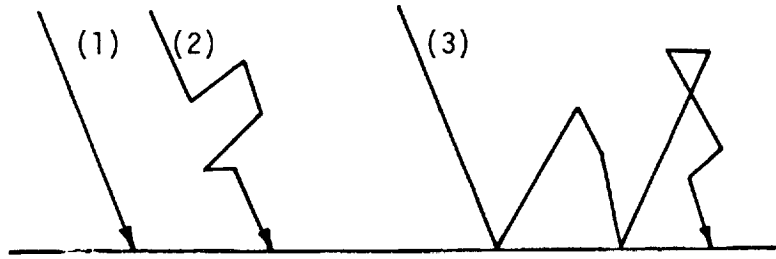

Figure 4-2. Sketch illustrating the three ways a specific photon can interact with the surface.

Write the total transmission through the atmosphere as

$$T_r(-\mu_0) = t(-\mu) + e^{-\tau^*/\mu_0} \quad (4-29)$$

Then, the total flux which reaches the surface *before any surface reflection occurs* is

$$\pi \mu_0 F_0 T_r(-\mu_0) \quad (4-30)$$

and the total flux reaching the surface *after multiple reflections and scatterings* between the surface and the atmosphere is

$$\pi \mu_0 F_0 T_r(-\mu_0) \left[\rho_s \bar{r} + \rho_s^2 \bar{r}^2 + \rho_s^3 \bar{r}^3 + \dots \right] \quad (4-31)$$

where \bar{r} is the spherical albedo of the atmosphere alone. (Note that the relative simplicity of this expression stems from the assumed Lambertian character of the surface. If the surface were not Lambertian, this

would be a much more complex problem—see Tanré.) The first term in the bracket represents flux which has been reflected once from the surface, and then scattered back down to the surface. The second term represents flux which is reflected upward from the surface, scattered down by the atmosphere, reflected back upwards by the surface, and finally scattered back downward by the atmosphere. The remaining terms are interpreted similarly as multiple reflections and scatterings between the surface and the atmosphere.

The total flux which reaches the surface from the multiple scattering, then, is the sum of equations (4-30) and (4-31)

$$\begin{aligned} F_T(\mu_0) &= \pi\mu_0 F_0 T_r(-\mu_0) \left[1 + \rho_s \bar{\tau} + \rho_s^2 \bar{\tau}^2 + \rho_s^3 \bar{\tau}^3 + \dots \right] \\ &= \frac{\pi\mu_0 F_0 T_r(-\mu_0)}{1 - \rho_s \bar{\tau}} \end{aligned} \quad (4-32)$$

since $\rho_s \bar{\tau} < 1$.

Since the surface is assumed to be Lambertian, the total flux reflected by the surface is

$$F_{\text{REF}}(\mu_0) = \rho_s F_T(\mu_0) = \frac{\pi\mu_0 F_0 \rho_s T_r(-\mu_0)}{1 - \rho_s \bar{\tau}} \quad (4-33)$$

Now, look at the total flux leaving the top of the atmosphere in the *specific direction* $\cos^{-1} \mu$. This too is composed of three parts (as shown in fig. 4-3):

1. A component of the incoming solar flux which is directly scattered into the direction $\cos^{-1} \mu$ before it reaches the surface

$$\pi\mu_0 F_0 R(\mu, \mu_0) \quad (4-34)$$

2. The total flux received at the surface, reflected by the surface, and *directly* attenuated by the atmosphere

$$\frac{\pi\mu_0 F_0 \rho_s T_r(-\mu_0)}{1 - \rho_s \bar{\tau}} e^{-\tau^*/\mu} \quad (4-35)$$

3. The total flux received at the surface, reflected by the surface, and *diffusely* attenuated by the atmosphere

$$\frac{\pi\mu_0 F_0 \rho_s T_r(-\mu_0)}{1 - \rho_s \bar{\tau}} t(\mu) \quad (4-36)$$

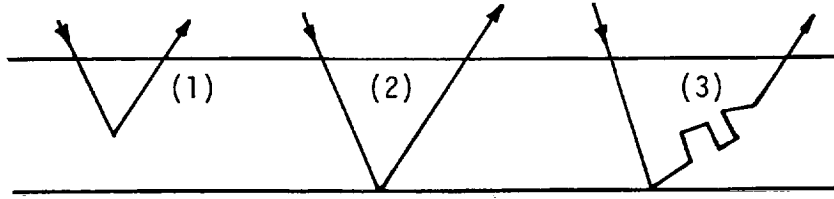

Figure 4-3. Sketch of some of the ways a given incoming photon can interact with the atmosphere and surface and finally escape.

Thus, writing

$$T_r(\mu) = t(\mu) + e^{-\tau^*}/\mu \quad (4-37)$$

we can write the total flux leaving the top of the atmosphere in the direction defined by μ as

$$F_{\text{REF}}(\mu, \mu_0) = \pi\mu_0 F_0 R(\mu, \mu_0) + \frac{\pi\mu_0 F_0 \rho_s T_r(-\mu_0) T_r(\mu)}{1 - \rho_s \bar{r}} \quad (4-38)$$

Following equation (4-16), we can define the total *bidirectional reflectance* of the atmosphere-surface as

$$r^*(\mu, \mu_0) = \frac{F_{\text{REF}}(\mu, \mu_0)}{F_{\text{INC}}} = R(\mu, \mu_0) + \frac{\rho_s T_r(-\mu_0) T_r(\mu)}{1 - \rho_s \bar{r}} \quad (4-39)$$

(Note again the symmetry $r^*(\mu, \mu_0) = r^*(\mu_0, \mu)$.) Then, by analogy with equation (4-20), if we multiply equation (4-39) by $2\mu d\mu$ and integrate over all μ , we get the planar albedo of the atmosphere and surface system,

$$r^*(\mu_0) = r(\mu_0) + \frac{\rho_s T_r(-\mu_0) \bar{T}_r}{1 - \rho_s \bar{r}} \quad (4-40)$$

where

$$\bar{T}_r = 2 \int_0^1 \mu T_r(\mu) d\mu \quad (4-41)$$

Finally, the spherical albedo is obtained from equation (4-40) by integrating over μ_0 :

$$\bar{r}^* = \bar{r} + \frac{\rho_s \bar{T}_r^2}{1 - \rho_s \bar{r}} \quad (4-42)$$

Liou (1980) develops these same relations in a much more rigorous way by applying the basic definitions of the R and T functions to the RTE. It is felt, however, that the more heuristic approach given here, following Tanré, brings the physics of the process more directly into

the derivation, and, hence, may be more appealing to the reader, who wants to see physically how the various terms react with each other.

Liou's development should not be ignored, however, as it permits one to derive the same results by a more rigorous manipulation of the basic definitions and concepts and, hence, to attain some fluency in the use of these more formal statements. In this same context, see also section 72 of Chandrasekhar (1960).

It should be pointed out that for homogeneous atmospheres $t(\mu) = t(-\mu)$, but this is not generally true for nonhomogeneous atmospheres; i.e., the upward transmission function for a nonhomogeneous atmosphere is not, in general, equal to the downward transmission.

Chapter 5

Approximate Analytical Solutions to the RTE

There are a number of approximate solutions to the various forms of the RTE we have developed so far, and considering their simplicity, for the Earth's atmosphere many of them are surprisingly accurate when compared with "exact" solutions. The reason for this is that, except in the cases of radiation through clouds, heavy fog, or haze, the Earth's atmosphere is optically thin. Many of the approximate solutions are based on thin atmospheres, which allow only very low orders of scattering to dominate, and thus, when applied to many problems or studies in the Earth's atmosphere, yield numerical solutions which compare very favorably in accuracy with much more sophisticated "exact" solutions. However, some care must be taken to insure that the solutions presented in this chapter are only applied under the conditions for which they were derived. Long-term familiarity with, and perhaps daily application of such solutions, frequently causes even the expert to forget the regions of applicability, so one must be wary of trying to apply these approximate results to problems for which the generating assumptions are not valid.

The first two solutions covered in this chapter—the thin-atmosphere approximation, and the single-scattering solution—are either applicable *only* to, or are generally more accurate when applied to, a thin atmosphere; i.e., an atmosphere dominated by low orders of scattering. This can occur in an atmosphere of small optical depth, or in an atmosphere of large optical depth if its absorption is also large—i.e., $\tilde{\omega}_\nu \ll 1$. (See the discussion in Irvine, 1968, or Irvine and Lenoble, 1973.) The sundry forms of the two-stream solution are applicable to atmospheres of any thickness.

The two-stream solutions, presented later in this chapter, and the Eddington solutions of the next chapter, are examples of a frequently recurring theme in RTE work, namely, the directional averaging of the radiance in order to achieve computationally tractable results. The methods of Schuster-Schwartzschild, Sagan-Pollack, and Coakley-Chylek all use different directional averaging devices to reduce the

radiances in the upper and lower hemispheres to constant parameters independent of direction. This process results in a pair of coupled linear differential equations with constant coefficients (for homogeneous atmospheres), one for the upward intensity and one for the downward intensity.

Thin-Atmosphere Approximation

The thin-atmosphere approximation is probably the most direct and simplest solution of the RTE. (We assume here only the azimuthally symmetric case.) It can be obtained directly from the RTE by simply assuming that the atmosphere is so thin optically that the derivatives

$$\frac{dI_\nu(\tau_\nu, \mu)}{d\tau_\nu}$$

can be replaced by their finite difference forms—see equations (5-7) and (5-8) and Coakley and Chylek, 1975.

Start from equation (2-41)

$$\mu \frac{dI_\nu(\tau_\nu, \mu)}{d\tau_\nu} = I_\nu(\tau_\nu, \mu) - \frac{\tilde{\omega}_\nu}{2} \int_{-1}^1 I_\nu(\tau_\nu, \mu') P(\mu, \mu') d\mu' \quad (5-1)$$

with the normalized, azimuthally averaged phase function

$$\frac{1}{2} \int_{-1}^1 P(\mu, \mu') = 1 \quad (5-2)$$

Recall from the discussion in chapter 2 that equation (5-1) contains both the direct and diffuse radiation components.

Separate the integral in equation (5-1) into the upward and downward components

$$\begin{aligned} \mu \frac{dI_\nu(\tau_\nu, \mu)}{d\tau_\nu} &= I_\nu(\tau_\nu, \mu) - \frac{\tilde{\omega}_\nu}{2} \int_{-1}^0 I_\nu(\tau_\nu, \mu') P(\mu, \mu') d\mu' \\ &\quad - \frac{\tilde{\omega}_\nu}{2} \int_0^1 I_\nu(\tau_\nu, \mu') P(\mu, \mu') d\mu' \end{aligned}$$

or

$$\begin{aligned} \mu \frac{dI_\nu(\tau_\nu, \mu)}{d\tau_\nu} &= I_\nu(\tau_\nu, \mu) - \frac{\tilde{\omega}_\nu}{2} \int_0^1 I_\nu(\tau_\nu, \mu') P(\mu, \mu') d\mu' \\ &\quad - \frac{\tilde{\omega}_\nu}{2} \int_0^1 I_\nu(\tau_\nu, -\mu') P(\mu, -\mu') d\mu' \end{aligned} \quad (5-3)$$

Now, let us distinguish the upward and downward components of intensity by the symbols

$$\begin{aligned} I_{\nu}^{\uparrow}(\tau_{\nu}, \mu) &= I_{\nu}(\tau_{\nu}, \mu) \\ I_{\nu}^{\downarrow}(\tau_{\nu}, \mu) &= I_{\nu}(\tau_{\nu}, -\mu) \end{aligned}$$

and then write equation (5-3) for each component separately. For the upward component

$$\begin{aligned} \mu \frac{dI_{\nu}^{\uparrow}(\tau_{\nu}, \mu)}{d\tau_{\nu}} &= I_{\nu}^{\uparrow}(\tau_{\nu}, \mu) - \frac{\tilde{\omega}_{\nu}}{2} \int_0^1 I_{\nu}^{\uparrow}(\tau_{\nu}, \mu') P(\mu, \mu') d\mu' \\ &\quad - \frac{\tilde{\omega}_{\nu}}{2} \int_0^1 I_{\nu}^{\downarrow}(\tau_{\nu}, \mu') P(\mu, -\mu') d\mu' \end{aligned} \quad (5-4)$$

To get the downward component, replace μ with $-\mu$ in the first, second, and fourth terms of equation (5-4). This is not necessary for I_{ν}^{\uparrow} in the third term, as this is the upward component of intensity which is scattered downward:

$$\begin{aligned} -\mu \frac{dI_{\nu}^{\downarrow}(\tau_{\nu}, \mu)}{d\tau_{\nu}} &= I_{\nu}^{\downarrow}(\tau_{\nu}, \mu) - \frac{\tilde{\omega}_{\nu}}{2} \int_0^1 I_{\nu}^{\uparrow}(\tau_{\nu}, \mu') P(-\mu, \mu') d\mu' \\ &\quad - \frac{\tilde{\omega}_{\nu}}{2} \int_0^1 I_{\nu}^{\downarrow}(\tau_{\nu}, \mu') P(-\mu, -\mu') d\mu' \end{aligned} \quad (5-5)$$

Recognizing that

$$P(-\mu, -\mu') = P(\mu, \mu')$$

(see eq. (1-43)) we can write equation (5-5) as

$$\begin{aligned} -\mu \frac{dI_{\nu}^{\downarrow}(\tau_{\nu}, \mu)}{d\tau_{\nu}} &= I_{\nu}^{\downarrow}(\tau_{\nu}, \mu) - \frac{\tilde{\omega}_{\nu}}{2} \int_0^1 I_{\nu}^{\uparrow}(\tau_{\nu}, \mu') P(-\mu, \mu') d\mu' \\ &\quad - \frac{\tilde{\omega}_{\nu}}{2} \int_0^1 I_{\nu}^{\downarrow}(\tau_{\nu}, \mu') P(\mu, \mu') d\mu' \end{aligned} \quad (5-6)$$

Now, replace the derivatives with the finite difference forms

$$\frac{dI_{\nu}^{\uparrow}(\tau_{\nu}, \mu)}{d\tau_{\nu}} \approx \frac{I_{\nu}^{\uparrow}(\tau_{\nu}, \mu) - I_{\nu}^{\uparrow}(0, \mu)}{\tau_{\nu}} \quad (5-7)$$

and

$$\frac{dI_{\nu}^{\downarrow}(\tau_{\nu}, \mu)}{d\tau_{\nu}} \approx \frac{I_{\nu}^{\downarrow}(\tau_{\nu}, \mu) - I_{\nu}^{\downarrow}(0, \mu)}{\tau_{\nu}} \quad (5-8)$$

Put equation (5-7) into equation (5-4) and solve for $I_{\nu}^{\uparrow}(0, \mu)$

$$I_{\nu}^{\uparrow}(0, \mu) = \left(1 - \frac{\tau_{\nu}}{\mu}\right) I_{\nu}^{\uparrow}(\tau_{\nu}, \mu) + \frac{\tau_{\nu} \tilde{\omega}_{\nu}}{2 \mu} \int_0^1 I_{\nu}^{\uparrow}(\tau_{\nu}, \mu') P(\mu, \mu') d\mu' + \frac{\tau_{\nu} \tilde{\omega}_{\nu}}{\mu} \int_0^1 I_{\nu}^{\downarrow}(\tau_{\nu}, \mu') P(\mu, -\mu') d\mu' \quad (5-9)$$

Note the physical significance of the terms in equation (5-9) as sketched in figure 5-1. The first term on the right-hand side is the upward intensity at τ_{ν} in the direction μ which is not scattered—it only undergoes absorption along the slant path from τ_{ν} to $\tau_{\nu} = 0$:

$$e^{-\tau_{\nu}/\mu} \approx 1 - \frac{\tau_{\nu}}{\mu} \quad \left(\frac{\tau_{\nu}}{\mu} \ll 1\right)$$

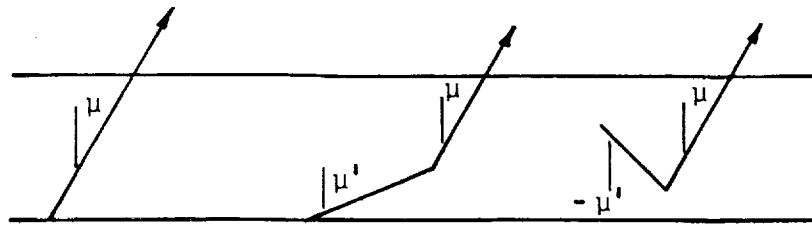

Figure 5-1. Sketch illustrating the physical interpretation of the terms of equation (5-9).

The second term is the upward intensity at τ_{ν} in the upward direction μ' which is scattered into the direction μ , and the third term is the downward intensity at τ_{ν} in the direction $-\mu'$ which is scattered upward into the direction μ .

Now, we want to eliminate the I_{ν}^{\downarrow} term in the second integral of equation (5-9). So we substitute equation (5-8) into equation (5-6) and solve for $I_{\nu}^{\downarrow}(\tau_{\nu}, \mu)$

$$I_{\nu}^{\downarrow}(\tau_{\nu}, \mu) = I_{\nu}^{\downarrow}(0, \mu) \left(1 - \frac{\tau_{\nu}}{\mu}\right) + \frac{\tau_{\nu} \tilde{\omega}_{\nu}}{\mu} \int_0^1 I_{\nu}^{\uparrow}(\tau_{\nu}, \mu') P(-\mu, \mu') d\mu' + \frac{\tau_{\nu} \tilde{\omega}_{\nu}}{\mu} \int_0^1 I_{\nu}^{\downarrow}(\tau_{\nu}, \mu') P(\mu, \mu') d\mu' \quad (5-10)$$

The terms in equation (5-10) have a similar interpretation to those of equation (5-9). If equation (5-10) is substituted into equation (5-9) and

only first-order terms in τ_ν are retained, then

$$I_\nu^\downarrow(\tau_\nu, \mu) \rightarrow I_\nu^\downarrow(0, \mu)$$

and equation (5-9) becomes

$$\begin{aligned} I_\nu^\uparrow(0, \mu) = & \left(1 - \frac{\tau_\nu}{\mu}\right) I_\nu^\uparrow(\tau_\nu, \mu) + \frac{\tau_\nu \tilde{\omega}_\nu}{\mu} \int_0^1 I_\nu^\uparrow(\tau_\nu, \mu') P(\mu, \mu') d\mu' \\ & + \frac{\tau_\nu \tilde{\omega}_\nu}{\mu} \int_0^1 I_\nu^\downarrow(0, \mu') P(\mu, -\mu') d\mu' \end{aligned} \quad (5-11)$$

We can get the reflection and transmission coefficients of a thin atmosphere directly from equation (5-11) (see Coakley and Chylek, 1975). To get the reflection function, assume a solar beam incident on the top of the atmosphere

$$2\pi I_\nu^\downarrow(0, \mu_0) = \pi F_0 \delta(\mu - \mu_0) \quad (5-12)$$

(the factor 2π arises from the azimuthal integration) and assume the incident diffuse radiation at the bottom of the atmosphere

$$2\pi I_\nu^\uparrow(\tau_\nu, \mu) = 0 \quad (5-13)$$

Then equation (5-11) becomes for this case

$$I_\nu^\uparrow(0, \mu) = \frac{\tau_\nu \tilde{\omega}_\nu F_0}{\mu} \frac{1}{2} P(\mu, -\mu_0) \quad (5-14)$$

The reflected flux is given by

$$F_\nu^\uparrow(\mu) = 2\pi \int_0^1 \mu I_\nu^\uparrow(0, \mu) d\mu = \frac{\pi}{2} \tau_\nu \tilde{\omega}_\nu F_0 \int_0^1 P(\mu, -\mu_0) d\mu \quad (5-15)$$

and from equation (4-17) the planetary albedo is

$$\tau(\mu_0) = \frac{1}{2} \frac{\tau_\nu \tilde{\omega}_\nu}{\mu_0} \int_0^1 P(\mu, -\mu_0) d\mu \quad (5-16)$$

We can use equation (5-11) to find the transmission function, $T(\mu_0)$, even though equation (5-11) describes the upward intensity component, by the simple artifice of letting the solar flux impinge on the *bottom* of the layer and examining the flux emerging from the *top* of the layer. Note that we use $T(\mu_0)$ rather than $t(\mu_0)$ to denote the transmission

function, as here we are determining the *total* transmission function and not just the diffuse component.

We have the boundary conditions

$$2\pi I_{\nu}^{\uparrow}(\tau_{\nu}, \mu) = \pi F_0 \delta(\mu - \mu_0) \quad (5-17)$$

and

$$2\pi I_{\nu}^{\downarrow}(0, \mu) = 0 \quad (5-18)$$

Put these into equation (5-11) to get

$$I_{\nu}^{\uparrow}(0, \mu) = \left(1 - \frac{\tau_{\nu}}{\mu}\right) \frac{F_0}{2} \delta(\mu - \mu_0) + \frac{\tau_{\nu}}{\mu} \frac{\tilde{\omega}_{\nu}}{2} \frac{F_0}{2} P(\mu, \mu_0)$$

Again the flux is given by equation (5-15)

$$F_{\nu}^{\uparrow}(0) = 2\pi\mu_0 \left(1 - \frac{\tau_{\nu}}{\mu}\right) \frac{F_0}{2} + 2\pi\tau_{\nu} \frac{\tilde{\omega}_{\nu}}{2} \frac{F_0}{2} \int_0^1 P(\mu', \mu_0) d\mu'$$

The transmission function is gotten from equation (4-19)

$$T(\mu) = \left(1 - \frac{\tau_{\nu}}{\mu_0}\right) + \frac{\tau_{\nu}}{\mu_0} \frac{\tilde{\omega}_{\nu}}{2} \int_0^1 P(\mu', \mu_0) d\mu' \quad (5-19)$$

The first term on the right-hand side of equation (5-19) represents the contribution of the direct transmission

$$e^{-\tau_{\nu}/\mu_0} \approx 1 - \frac{\tau_{\nu}}{\mu_0} \quad \left(\frac{\tau_{\nu}}{\mu_0} \ll 1\right)$$

and the second term, which is analogous to equation (5-16), is the transmission function for the diffuse term.

We can use the normalized property of the phase function, equation (1-27), to write this in another form. From equation (1-27) and azimuthal symmetry, we have

$$\frac{1}{2} \int_{-1}^1 P(\mu, \mu') d\mu' = 1$$

or

$$\begin{aligned} \frac{1}{2} \int_{-1}^0 P(\mu, \mu') d\mu' + \frac{1}{2} \int_0^1 P(\mu, \mu') d\mu' &= 1 \\ \frac{1}{2} \int_0^1 P(\mu, -\mu') d\mu' + \frac{1}{2} \int_0^1 P(\mu, \mu') d\mu' &= 1 \end{aligned}$$

and since

$$\begin{aligned} P(\mu, \mu') &= P(\mu', \mu) \\ P(\mu, -\mu') &= P(-\mu, \mu') \end{aligned}$$

we can write the integral form of equation (5-19) as

$$\frac{1}{2} \int_0^1 P(\mu', \mu_0) d\mu' = 1 - \frac{1}{2} \int_0^1 P(\mu', -\mu_0) d\mu'$$

and hence write equation (5-19) as

$$T(\mu_0) = 1 - \frac{\tau_\nu}{\mu_0} \left[1 - \tilde{\omega}_\nu + \frac{\tilde{\omega}_\nu}{2} \int_0^1 P(\mu, -\mu_0) d\mu \right] \quad (5-20)$$

Equations (5-16) and (5-20) show that for a thin atmosphere, both the albedo and the transmission functions are linear functions of optical depth.

Define

$$\beta(\mu_0) = \frac{1}{2} \int_0^1 P(\mu, -\mu_0) d\mu \quad (5-21)$$

Then from equation (5-16)

$$r(\mu_0) = \frac{\tau_\nu}{\mu_0} \tilde{\omega}_\nu \beta(\mu_0) \quad (5-22)$$

And from equation (5-20)

$$T(\mu_0) = 1 - \frac{\tau_\nu}{\mu_0} [1 - \tilde{\omega}_\nu + \tilde{\omega}_\nu \beta(\mu_0)] \quad (5-23)$$

Finally, if we define

$$\bar{\beta} = \int_0^1 \beta(\mu_0) d\mu_0 \quad (5-24)$$

we can get the spherical albedo and spherical transmission function by using equations (5-22) and (5-23) in equations (4-24) and (4-25)

$$\bar{r} = 2\tau_\nu \tilde{\omega}_\nu \bar{\beta} \quad (5-25)$$

$$\bar{T} = 1 - 2\tau_\nu (1 - \tilde{\omega}_\nu + \tilde{\omega}_\nu \bar{\beta}) \quad (5-26)$$

The quantities $\beta(\mu_0)$ and $\bar{\beta}$ are used quite extensively in the literature, especially that pertaining to the derivation of approximate solutions to the RTE. The quantity $\beta(\mu_0)$ is the *backscatter fraction* for a

beam of radiation entering the atmosphere at the angle $\cos^{-1} \mu_0$. This is geometrically proportional to the fraction of the total surface area of the phase function above the horizontal plane through the scattering center, as sketched in figure 5-2. The quantity $\bar{\beta}$ is the *integrated backscatter fraction* over the whole range of entry angles. Azimuthal symmetry has been assumed throughout this section, and hence, also in the definition of $\beta(\mu_0)$ and $\bar{\beta}$.

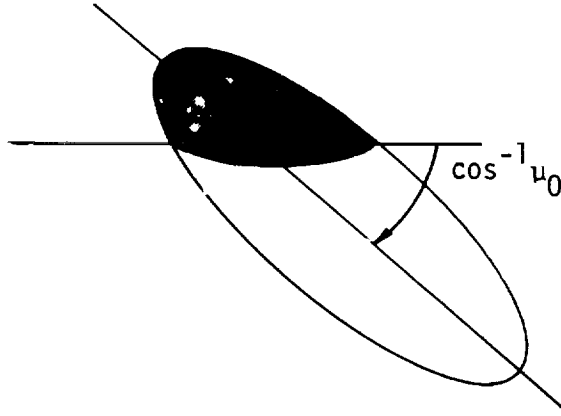

Figure 5-2. Interpretation of the backscatter fraction. The phase function is the Henyey-Greenstein type for small asymmetry parameter, g .

Wiscombe and Grams (1976) discuss these backscatter fractions in detail and give integral methods of evaluating them for general phase functions. Table 5-1 shows $\beta(\mu_0)$ computed by their method for various values of g (asymmetrical parameter) and μ_0 , and table 5-2 shows values of $\bar{\beta}$. Both tables are for the Henyey-Greenstein phase function. The table data are also plotted in two accompanying figures (figs. 5-3 and 5-4).

The tables reflect one's intuition about the behavior of $\beta(\mu_0)$ and $\bar{\beta}$. For isotropic scattering, $\beta(\mu_0) = \bar{\beta} = 1/2$ for all μ_0 (one-half of the radiation is scattered forward and one-half is scattered backward for any entry angle). For very elongated phase functions (g near 1), most of the radiation is scattered in the forward direction. Hence, both $\beta(\mu)$ and $\bar{\beta}$ approach zero (very little backscattering). For very low incidence angles near 90 degrees ($\mu \rightarrow 0$) a somewhat higher fraction is backscattered than for near-normal incidence angles, $\beta(\mu = 1) > \beta(\mu_0 = 0)$.

The reflection and transmission functions from equations (5-22) and (5-23) are compared with some exact computations using the doubling method (Liou, 1973) in figures 5-5 and 5-6. Note that, as expected,

TABLE 5-1. VALUES OF $\beta(\mu_0)$ vs. g FOR VARIOUS μ_0
 [For the Henyey-Greenstein phase function]

g	$\mu_0 = 0.1$	$\mu_0 = 0.2$	$\mu_0 = 0.3$	$\mu_0 = 0.4$	$\mu_0 = 0.5$
0.00	0.500	0.500	0.500	0.500	0.500
.05	.496	.492	.489	.485	.481
.10	.492	.485	.477	.470	.462
.15	.489	.477	.466	.454	.443
.20	.484	.469	.454	.438	.423
.25	.480	.460	.441	.422	.403
.30	.476	.451	.428	.404	.382
.35	.471	.442	.413	.386	.360
.40	.465	.431	.398	.367	.337
.45	.459	.419	.381	.346	.313
.50	.452	.405	.362	.323	.288
.55	.443	.390	.341	.298	.262
.60	.434	.372	.318	.272	.234
.65	.421	.350	.291	.243	.205
.70	.406	.324	.260	.211	.174
.75	.385	.292	.225	.177	.144
.80	.356	.252	.185	.142	.113
.85	.314	.202	.141	.105	.085
.90	.247	.141	.094	.069	.053
.95	.141	.072	.046	.033	.026
1.00	.0	.0	.0	.0	.0

the solutions (5-22) and (5-23) for the thin atmosphere ($\tau = 0.0625$) show better agreement with the exact calculations than do those for the thicker atmosphere ($\tau = 0.25$). For both thicknesses, the agreement is also better for steep incidence angles ($\mu_0 \approx 1$) than for shallow incidence angles ($\mu_0 \approx 0$), because for steep entries there is less chance for multiple scattering to occur.

Single-Scatter Solution

The single-scattering solution to the intensity equation is probably the next simplest solution to the RTE. In this solution, we permit the incoming solar radiation to be scattered only once, and compute the resulting upward and downward intensities resulting from this single scatter.

Many phenomena involving atmospheric scattering can be adequately represented by the single-scattering approximation, the most

TABLE 5-1. Concluded

g	$\mu_0 = 0.6$	$\mu_0 = 0.7$	$\mu_0 = 0.8$	$\mu_0 = 0.9$	$\mu_0 = 1.0$
0.00	0.500	0.500	0.500	0.500	0.500
.05	.477	.474	.470	.466	.463
.10	.455	.440	.433	.425	.423
.15	.432	.421	.410	.399	.389
.20	.409	.394	.380	.367	.353
.25	.385	.368	.351	.334	.319
.30	.361	.340	.321	.303	.286
.35	.336	.313	.292	.273	.255
.40	.311	.286	.263	.243	.225
.45	.284	.258	.236	.215	.197
.50	.258	.231	.208	.188	.171
.55	.230	.204	.181	.163	.147
.60	.203	.177	.156	.139	.124
.65	.175	.151	.132	.116	.103
.70	.147	.125	.109	.095	.084
.75	.119	.101	.087	.076	.067
.80	.093	.078	.066	.058	.051
.85	.067	.056	.048	.041	.036
.90	.043	.036	.030	.026	.023
.95	.021	.017	.014	.012	.011
1.00	.0	.0	.0	.0	.0

notable exceptions being the scattering characteristics of clouds, heavy haze, and fog, and possibly heavy aerosol concentrations. The extinction coefficient for background aerosols in the stratosphere, for example, is of the order of 2×10^{-4} km. Thus, the mean free path for stratospheric aerosol extinction is of the order of 5000 km, and the single-scattering solution should suffice for all but the most shallow solar flux entry angles, along which the possibility of more than one scatter might take place (see Buglia, 1982). In the troposphere, a clear-day extinction coefficient might be of the order of 2×10^{-2} km, giving a mean free path of the order of 50 km, so that even here the single-scatter solution might be used for some problems. In a heavy fog or haze, the extinction coefficient might be of the order of 1 to 10 km, and obviously one could *not* try to use the single-scatter solution under these conditions.

We start with the formal solutions for the upward and downward intensities, equations (3-5) and (3-7), which we now write, dropping the

TABLE 5-2. VALUE OF $\bar{\beta}$ vs. g
 [For the Henyey-Greenstein phase function]

g	$\bar{\beta}$	g	$\bar{\beta}$
0.00	0.500	0.55	0.283
.05	.481	.60	.261
.10	.462	.65	.238
.15	.444	.70	.214
.20	.425	.75	.188
.25	.405	.80	.161
.30	.386	.85	.131
.35	.366	.90	.098
.40	.346	.95	.058
.45	.326	1.00	.000
.50	.305		

ν subscript, as

$$I(\tau, \mu, \phi) = I(\tau^*, \mu, \phi)e^{-(\tau^* - \tau)/\mu} + \int_{\tau}^{\tau^*} J(\tau', \mu, \phi)e^{-(\tau' - \tau)/\mu} \frac{d\tau'}{\mu} \quad (5-27)$$

$$I(\tau, -\mu, \phi) = I(0, -\mu, \phi)e^{-\tau/\mu} + \int_0^{\tau} J(\tau', -\mu, \phi)e^{-(\tau - \tau')/\mu} \frac{d\tau'}{\mu} \quad (5-28)$$

The source function, $J(\tau, \mu, \phi)$, is the singly scattered incoming solar radiance, which we write as

$$J(\tau, \mu, \phi) = \pi F_0 e^{-\tau/\mu_0} \tilde{\omega} \frac{P(\mu, \phi; -\mu_0, \phi_0)}{4\pi} \quad (5-29)$$

and which is the product of three terms:

- $\pi F_0 e^{-\tau/\mu_0}$ the incoming direct solar intensity attenuated to the level τ
- $\tilde{\omega}$ the single-scattering albedo; i.e., the fraction of the incoming solar radiance which undergoes scattering
- $\frac{P(\mu, \phi; -\mu_0, \phi_0)}{4\pi}$ the fraction of the scattered radiance which is scattered from the direction $(-\mu_0, \phi_0)$ into the direction (μ, ϕ) .

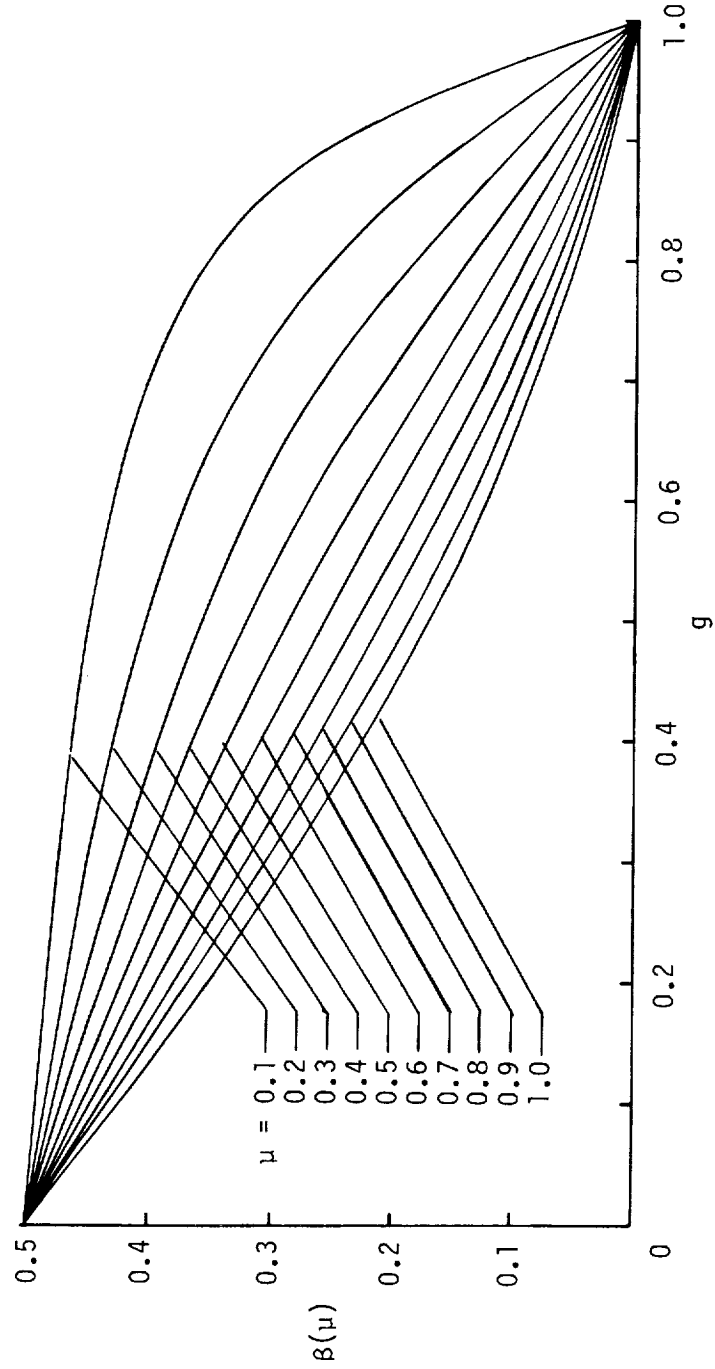

Figure 5-3. Backscatter fraction, $\beta(\mu)$, for the Henyey-Greenstein phase function vs. g for various values of the incoming beam direction, $\cos^{-1} \mu$.

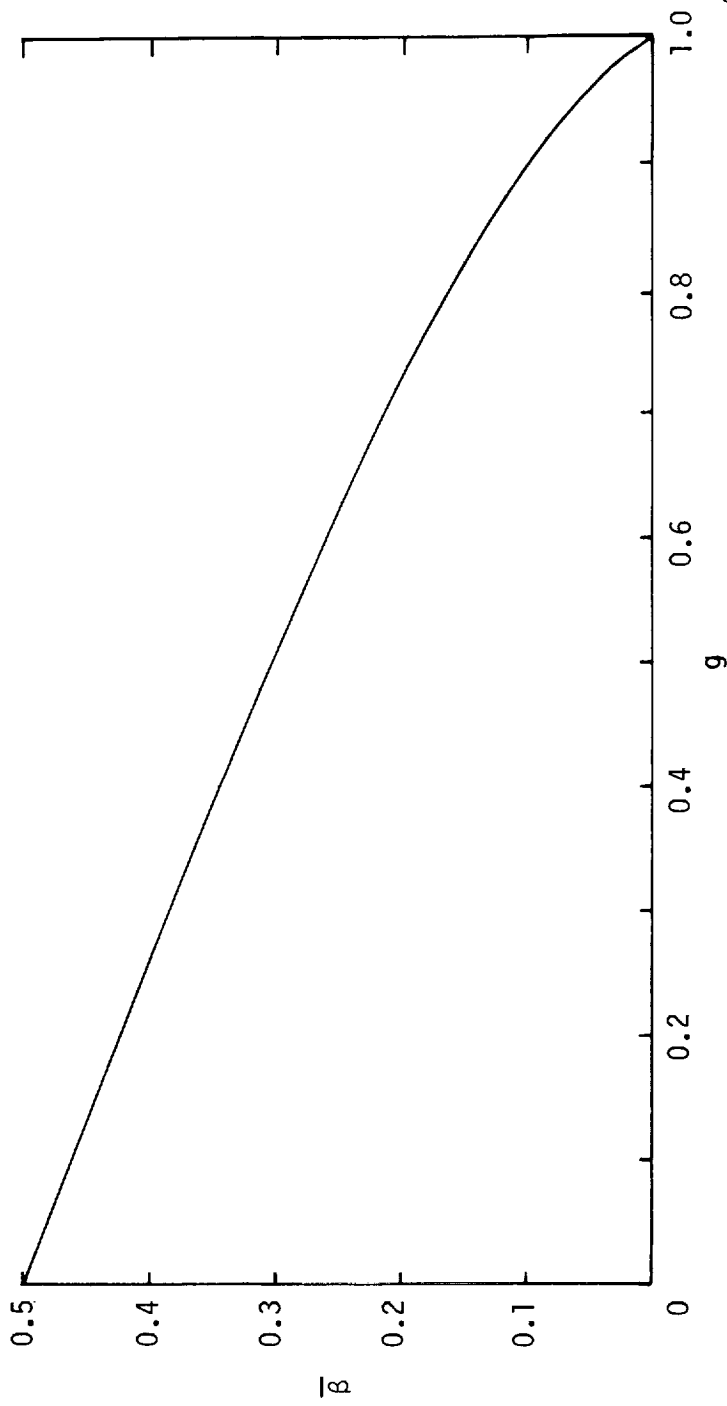

Figure 5-4. Integrated backscatter fraction, $\bar{\beta}$, for the Henyey-Greenstein phase function vs. g .

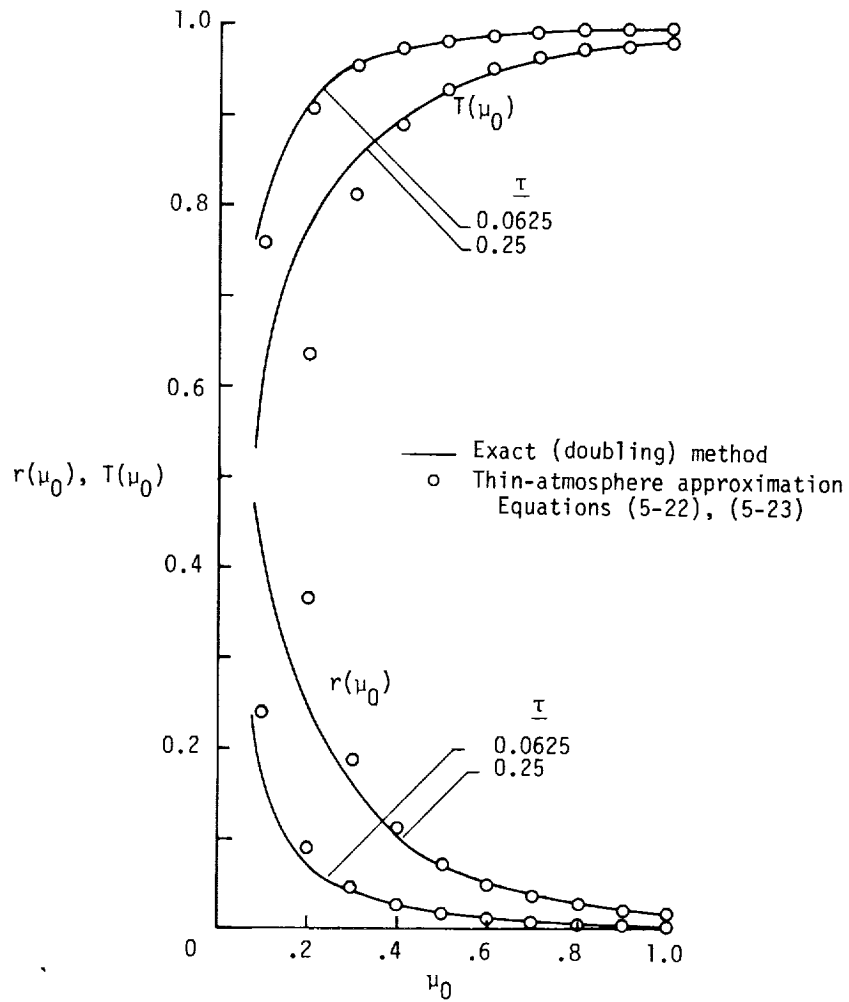

Figure 5-5. Comparison of the thin-atmosphere approximation, equations (5-22) and (5-23), with the exact (doubling) method for two values of the optical depth, $\tau = 0.0625$ and $\tau = 0.25$. The Henyey-Greenstein phase function was used with $g = 0.75$, $\tilde{\omega}_0 = 1.0$.

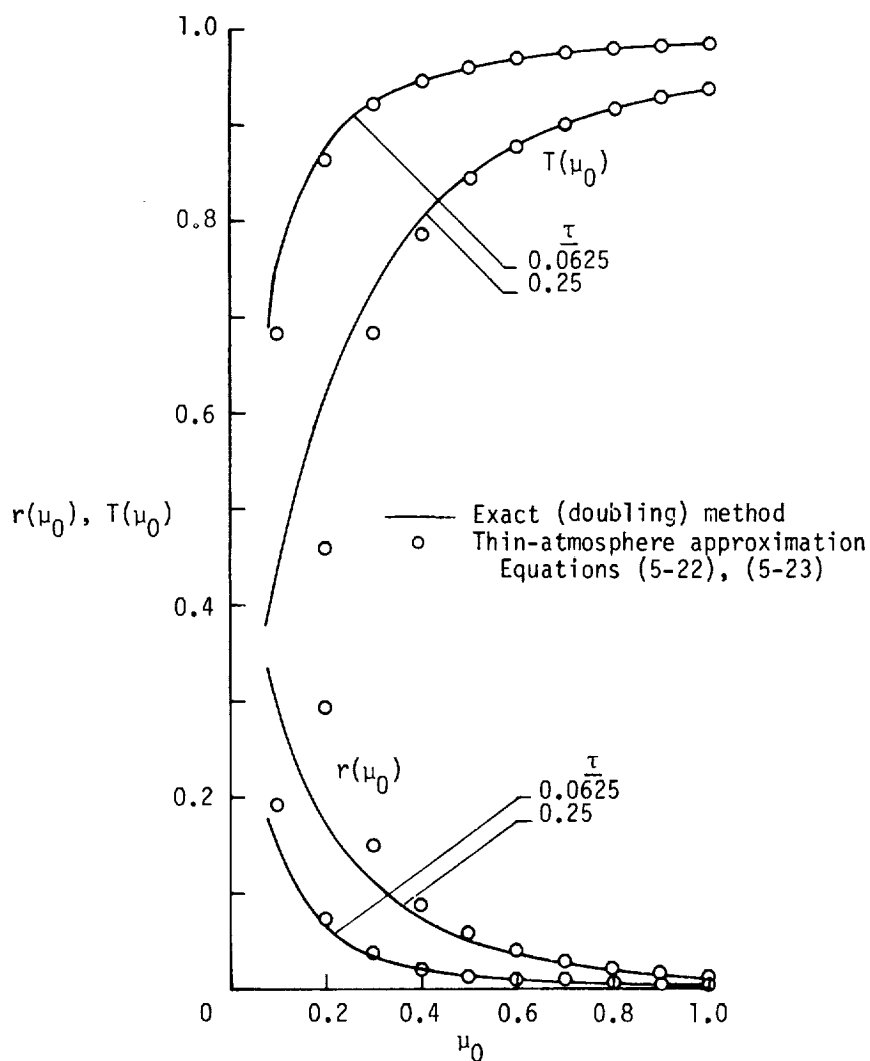

Figure 5-6. Comparison of the thin-atmosphere approximation, equations (5-22) and (5-23), with the exact (doubling) method for two values of the optical depth, $\tau = 0.0625$ and $\tau = 0.25$. The Henyey-Greenstein phase function was used with $g = 0.75$, $\tilde{\omega}_0 = 0.8$.

We assume as boundary conditions

$$I(0, -\mu, \phi) = 0 \quad (5-30)$$

$$I(\tau^*, \mu, \phi) = 0 \quad (5-31)$$

i.e., no *diffuse* radiation enters the top or bottom of the atmosphere.

From equation (5-27), with equation (5-29) and the boundary conditions

$$\begin{aligned} I(\tau, \mu, \phi) &= \left(\frac{\tilde{\omega}}{4\pi}\right) \pi F_0 P(\mu, \phi : -\mu_0, \phi_0) \int_{\tau}^{\tau^*} e^{-\tau'/\mu} e^{-(\tau'-\tau)/\mu} \frac{d\tau'}{\mu} \\ &= \frac{\tilde{\omega}}{4} F_0 P(\mu, \phi : -\mu_0, \phi_0) \frac{\mu_0}{\mu + \mu_0} e^{\tau/\mu} \\ &\quad \times \left[e^{-\tau\left(\frac{1}{\mu_0} + \frac{1}{\mu}\right)} - e^{-\tau^*\left(\frac{1}{\mu_0} + \frac{1}{\mu}\right)} \right] \end{aligned} \quad (5-32)$$

In particular, at the top of the atmosphere $\tau = 0$, and we get

$$I(0, \mu, \phi) = \frac{\tilde{\omega}\mu_0 F_0}{4(\mu + \mu_0)} P(\mu, \phi : -\mu_0, \phi_0) \left[1 - e^{-\tau^*\left(\frac{1}{\mu_0} + \frac{1}{\mu}\right)} \right] \quad (5-33a)$$

Comparison of equation (5-33a) with equation (4-8) shows that we can write the reflection coefficient for single scattering as

$$R(\mu, \mu_0) = \frac{\tilde{\omega}}{4} \frac{P(\mu, -\mu_0)}{\mu + \mu_0} \left[1 - e^{-\tau^*\left(\frac{1}{\mu_0} + \frac{1}{\mu}\right)} \right] \quad (5-33b)$$

In a similar way, we get the downward component of the intensity by substituting equation (5-29) and the boundary conditions into equation (5-28)

$$\begin{aligned} I(\tau, -\mu, \phi) &= \left(\frac{\tilde{\omega}}{4\pi}\right) \pi F_0 P(-\mu, \phi : -\mu_0, \phi_0) \int_0^{\tau} e^{-\tau'/\mu} e^{-(\tau-\tau')/\mu} \frac{d\tau'}{\mu} \\ &= \frac{\tilde{\omega}}{4} F_0 P(-\mu, \phi : -\mu_0, \phi_0) \frac{e^{-\tau/\mu}}{\mu} \int_0^{\tau} e^{-\tau'\left(\frac{1}{\mu_0} - \frac{1}{\mu}\right)} d\tau' \end{aligned}$$

Here, we must distinguish between two cases:

1. $\mu = \mu_0$, and
2. $\mu \neq \mu_0$.

For case 1 we get immediately

$$I_1(\tau, -\mu, \phi) = \frac{\tilde{\omega}}{4} F_0 P(-\mu, \phi : -\mu_0, \phi_0) \frac{\tau}{\mu_0} e^{-\tau/\mu_0} \quad (5-34)$$

and for case 2,

$$I_2(\tau, -\mu, \phi) = \frac{\tilde{\omega}}{4} \frac{\mu_0 F_0}{\mu - \mu_0} P(-\mu, \phi : -\mu_0, \phi_0) \left[e^{-\tau/\mu} - e^{-\tau/\mu_0} \right] \quad (5-35)$$

Emerging from the bottom of the atmosphere

$$I_1(\tau^*, -\mu, \phi) = \frac{\tilde{\omega}}{4} F_0 P(-\mu, \phi : -\mu_0, \phi_0) \frac{\tau^*}{\mu_0} e^{-\tau^*/\mu_0} \quad (5-36a)$$

$$I_2(\tau^*, -\mu, \phi) = \frac{\tilde{\omega}}{4} \frac{\mu_0 F_0}{\mu - \mu_0} P(-\mu, \phi : -\mu_0, \phi_0) \left[e^{-\tau^*/\mu} - e^{-\tau^*/\mu_0} \right] \quad (5-36b)$$

Comparing equation (5-36b) with equation (4-9) gives the diffuse transmission coefficient for single scattering

$$t_2(\mu, \mu_0) = \frac{\tilde{\omega}}{4} \frac{P(-\mu, -\mu_0)}{\mu - \mu_0} \left[e^{-\tau^*/\mu} - e^{-\tau^*/\mu_0} \right] \quad (\mu \neq \mu_0) \quad (5-37a)$$

The direct component of the transmission coefficient is, of course,

$$e^{-\tau^*/\mu_0}$$

For case 1 ($\mu = \mu_0$), the diffuse part of the transmission function is

$$t_1(\mu, \mu_0) = \frac{\tilde{\omega}}{4} \frac{\tau^*}{\mu_0^2} e^{-\tau^*/\mu_0} P(-\mu_0, \phi_0 : -\mu_0, \phi_0) \quad (\mu = \mu_0) \quad (5-37b)$$

We can now easily show that for a thin atmosphere, $\tau^* \ll 1$, equations (5-32) and (5-35) reduce to the thin-atmosphere solution derived earlier. For $\tau^* \ll 1$, we get from equation (5-32)

$$I(\tau, \mu, \phi) = \frac{\tilde{\omega}}{4} \frac{F_0 \tau^*}{\mu} P(\mu, \phi : -\mu_0, \phi_0) \quad (5-38)$$

Assuming azimuthal symmetry the upward flux at $\tau = 0$ is

$$F^\uparrow(0) = 2\pi \int_0^1 \mu \frac{\tilde{\omega}}{4} F_0 \frac{\tau^*}{\mu} P(\mu, -\mu_0) d\mu = \pi \tilde{\omega} F_0 \tau^* \beta(\mu_0)$$

which is identical to equation (5-15), derived from the thin-atmosphere assumption.

The direct component of the downward flux is

$$F^\downarrow(\tau^*) = \pi F_0 \mu_0 e^{-\tau^*/\mu_0} \approx \pi F_0 \mu_0 \left(1 - \frac{\tau^*}{\mu_0}\right) \quad (5-39)$$

The diffuse downward component of intensity becomes, from equation (5-36b)

$$I(\tau^*, -\mu, \phi) = \frac{\tilde{\omega}}{4} \frac{\mu_0 F_0}{\mu - \mu_0} P(-\mu, \phi; -\mu_0, \phi_0) \left[1 - \frac{\tau^*}{\mu} - 1 + \frac{\tau^*}{\mu_0}\right] = \frac{\tilde{\omega}}{4} F_0 \frac{\tau^*}{\mu} P(-\mu, -\mu_0)$$

and the diffuse component of the downward flux becomes

$$F^\downarrow(\tau^*) = 2\pi \int_0^1 \mu \frac{\tilde{\omega}}{4} F_0 \frac{\tau^*}{\mu} P(-\mu, -\mu_0) d\mu = \pi \tilde{\omega} F_0 \tau^* [1 - \beta(\mu_0)]$$

The total downward flux is thus

$$F^\downarrow(\tau^*) = \pi F_0 \mu_0 \left(1 - \frac{\tau^*}{\mu_0}\right) + \pi F_0 \tilde{\omega} \tau^* [1 - \beta(\mu_0)]$$

From this, the total transmission function emerges as

$$T(\mu_0) = 1 - \frac{\tau^*}{\mu_0} [1 - \tilde{\omega} + \tilde{\omega} \beta(\mu_0)]$$

which is identical to equation (5-23). Note the difference between the thin-atmosphere and single-scattering solutions. The single-scattering solution makes no assumptions about the thickness of the atmosphere—it only assumes that the photons are scattered only once.

Two-Stream Solutions

The two-stream solutions are, in general, arrived at by writing the RTE for the upward and downward components separately, and assuming that the upward intensity is constant over the upper hemisphere and independent of the angle μ , and that the downward component is a different constant over the lower hemisphere, also independent of μ . The differential equations each involve an integral, and the method of approximating the integral leads to a set of two linear differential equations. These equations have constant coefficients when applied to homogeneous atmospheres, as they are here.

We consider in this chapter three such methods of approximating the integral mentioned above. These lead to well-known approximate solutions—the Schuster-Schwartzschild approximation, the Sagan-Pollack approximation, and the Coakley-Chylek approximation. This third form, the C-C approximation, appears to have a slightly less rigorous formulation than the others, but it retains the dependence of the solution on the solar incidence angle, μ_0 . When appropriately applied, these equations all give numerical results which are in good agreement with other solutions.

The differential equations resulting from these three approaches are identical in algebraic form, the only differences appearing in the terms making up the constant numerical coefficients.

These three sets of two-stream approximations will be derived in this subsection. The reader is invited to examine the excellent review article by Meador and Weaver (1980), in which a number of well-known approximations, including other than the classical two-stream solutions developed here, are discussed and compared. Meador and Weaver neatly identify the theoretical thread common to all of these methods and show that they all reduce to the same algebraic form, except for the grouping and definition of some constant algebraic parameters. The paper by Lyzenga (1973) is also worthy reading, in that he shows that the Sagan and Pollack formulation can in fact be rigorously derived by assuming a two-point Gaussian quadrature formula to approximate the integrals mentioned above. He also shows that a single transformation relates the two-stream and the Eddington approximation discussed in the next chapter. Lyzenga's approach is used below to derive the Sagan-Pollack equations.

The two-stream analysis is applied to the azimuthally symmetric form of the RTE, for either the total intensity (direct plus diffuse, eq. (2-41)), or for the diffuse component only (eq. (2-50)). We will not derive in detail all the possible combinations here, as the repetition would serve no purpose, but will derive one total intensity solution and one diffuse intensity solution. Some limited numerical comparisons will also be given.

The Schuster-Schwartzschild (S-S), the Sagan-Pollack (S-P), and the Coakley-Chylek (C-C) equations can all be reduced to the same differential equation form. These three forms will be derived separately below, and the general form of the solution given.

Schuster-Schwartzschild (ref. e.g., *Özisik, 1973*). Start with the form of equation (2-41) and write the upward and downward components separately, as in equations (5-4) and (5-6). We will drop

the subscript ν from the I , the τ , and the $\tilde{\omega}$, but must keep in mind that these developments are for monochromatic radiation only.

$$\begin{aligned} \mu \frac{dI^\uparrow(\tau, \mu)}{d\tau} &= I^\uparrow(\tau, \mu) - \frac{\tilde{\omega}}{2} \int_0^1 I^\uparrow(\tau, \mu') P(\mu, \mu') d\mu' \\ &\quad - \frac{\tilde{\omega}}{2} \int_0^1 I^\downarrow(\tau, \mu') P(\mu, -\mu') d\mu' \end{aligned} \quad (5-40)$$

$$\begin{aligned} -\mu \frac{dI^\downarrow(\tau, \mu)}{d\tau} &= I^\downarrow(\tau, \mu) - \frac{\tilde{\omega}}{2} \int_0^1 I^\uparrow(\tau, \mu') P(\mu, -\mu') d\mu' \\ &\quad - \frac{\tilde{\omega}}{2} \int_0^1 I^\downarrow(\tau, \mu') P(\mu, \mu') d\mu' \end{aligned} \quad (5-41)$$

Multiply equation (5-40) by $d\mu$ and integrate from 0 to 1

$$\begin{aligned} \frac{d}{d\tau} \int_0^1 \mu I^\uparrow(\tau, \mu) d\mu &= \int_0^1 I^\uparrow(\tau, \mu) d\mu - \frac{\tilde{\omega}}{2} \int_0^1 d\mu \int_0^1 I^\uparrow(\tau, \mu') P(\mu, \mu') d\mu' \\ &\quad - \frac{\tilde{\omega}}{2} \int_0^1 d\mu \int_0^1 I^\downarrow(\tau, \mu') P(\mu, -\mu') d\mu' \end{aligned} \quad (5-42)$$

Interchange the order of integration in the last two terms

$$\begin{aligned} \frac{d}{d\tau} \int_0^1 \mu I^\uparrow(\tau, \mu) d\mu &= \int_0^1 I^\uparrow(\tau, \mu) d\mu - \frac{\tilde{\omega}}{2} \int_0^1 I^\uparrow(\tau, \mu') d\mu' \int_0^1 P(\mu, \mu') d\mu \\ &\quad - \frac{\tilde{\omega}}{2} \int_0^1 I^\downarrow(\tau, \mu') P(\mu, -\mu') d\mu' \end{aligned} \quad (5-43)$$

Since by equation (1-33) and the symmetry in μ, μ' ,

$$P(\mu, -\mu') = P(-\mu, \mu')$$

we have with the definition of equation (5-21)

$$\begin{aligned} \frac{d}{d\tau} \int_0^1 \mu I^\uparrow(\tau, \mu) d\mu &= \int_0^1 I^\uparrow(\tau, \mu) d\mu - \tilde{\omega}[1 - \beta(\mu)] \int_0^1 I^\uparrow(\tau, \mu') d\mu' \\ &\quad - \tilde{\omega}\beta(\mu) \int_0^1 I^\downarrow(\tau, \mu') d\mu' \end{aligned} \quad (5-44)$$

To this point, equation (5-44) is exact—at least insofar as the differential equation (5-40) is exact. Now, we make one of the approximations

mentioned above—we assume I to be independent of μ in each hemisphere, so that $I^\uparrow(\tau, \mu) \rightarrow I^\uparrow(\tau)$ (and similarly for I^\downarrow). This gives the S-S approximation

$$\int_0^1 \mu I^\uparrow(\tau, \mu) d\mu \approx \frac{1}{2} I^\uparrow(\tau) \quad (5-45)$$

and we write equation (5-44) in the form

$$\frac{1}{2} \frac{dI^\uparrow(\tau)}{d\tau} = I^\uparrow(\tau) - \tilde{\omega}[I - \beta(\mu)]I^\uparrow(\tau) - \tilde{\omega}\beta(\mu)I^\downarrow(\tau) \quad (5-46)$$

In a similar manner we can develop equation (5-41) to the form

$$-\frac{1}{2} \frac{dI^\downarrow(\tau)}{d\tau} = I^\downarrow(\tau) - \tilde{\omega}\beta(\mu)I^\uparrow(\tau) - \tilde{\omega}[I - \beta(\mu)]I^\downarrow(\tau) \quad (5-47)$$

Equations (5-46) and (5-47) are the S-S form of the differential equations describing the upward and downward components of the total intensity fields in the two-stream approximation.

Sagan-Pollack (Sagan and Pollack, 1967; see also Lyzenga, 1973).

Again we start with equation (2-41) with the subscript ν dropped from I , τ , and $\tilde{\omega}$

$$\mu \frac{dI(\tau, \mu)}{d\tau} = I(\tau, \mu) - \frac{\tilde{\omega}}{2} \int_{-1}^1 I(\tau, \mu') P(\mu, \mu') d\mu' \quad (5-48)$$

Lyzenga argues that instead of taking I^\uparrow and I^\downarrow to be some average value of I over their respective hemispheres, it is more appropriate to be guided by the two-point Gaussian quadrature method of numerical integration, and take for the average value of I that value which would be obtained if we solved equation (5-48) along the ray given by $\mu = \pm 1/\sqrt{3}$. This conclusion can be substantiated more formally from equation (2-41), if we replace the integral with a two-point Gaussian quadrature and write our equation for each ray separately. This gives the pair of equations

$$\frac{1}{\sqrt{3}} \frac{dI^\uparrow(\tau)}{d\tau} = I^\uparrow(\tau) - \frac{\tilde{\omega}}{2} \int_{-1}^1 I(\tau, \mu') P\left(\frac{1}{\sqrt{3}}, \mu'\right) d\mu' \quad (5-49)$$

and

$$-\frac{1}{\sqrt{3}} \frac{dI^\downarrow(\tau)}{d\tau} = I^\downarrow(\tau) - \frac{\tilde{\omega}}{2} \int_{-1}^1 I(\tau, \mu') P\left(-\frac{1}{\sqrt{3}}, \mu'\right) d\mu' \quad (5-50)$$

Apply the Gaussian two-point quadrature formula to the integrals in equations (5-49) and (5-50)

$$\int_{-1}^1 I(\tau, \mu') P\left(\frac{1}{\sqrt{3}}, \mu'\right) d\mu' \approx I^\uparrow(\tau) P\left(\frac{1}{\sqrt{3}}, \frac{1}{\sqrt{3}}\right) + I^\downarrow(\tau) P\left(\frac{1}{\sqrt{3}}, -\frac{1}{\sqrt{3}}\right) \quad (5-51)$$

$$\int_{-1}^1 I(\tau, \mu') P\left(-\frac{1}{\sqrt{3}}, \mu'\right) d\mu' \approx I^\uparrow(\tau) P\left(-\frac{1}{\sqrt{3}}, \frac{1}{\sqrt{3}}\right) + I^\downarrow(\tau) P\left(-\frac{1}{\sqrt{3}}, -\frac{1}{\sqrt{3}}\right) \quad (5-52)$$

If we use the two-term expansion of the phase function, equation (2-42), we get

$$P(\mu, \mu') = 1 + \tilde{\omega}_1 P_1(\mu) P_1(\mu')$$

and hence, the integrals in equations (5-51) and (5-52) become, respectively,

$$I^\uparrow(\tau) \left(1 + \frac{\tilde{\omega}_1}{3}\right) + I^\downarrow(\tau) \left(1 - \frac{\tilde{\omega}_1}{3}\right)$$

and

$$I^\uparrow(\tau) \left(1 - \frac{\tilde{\omega}_1}{3}\right) + I^\downarrow(\tau) \left(1 + \frac{\tilde{\omega}_1}{3}\right)$$

and equations (5-49) and (5-50) become

$$\frac{1}{\sqrt{3}} \frac{dI^\uparrow(\tau)}{d\tau} = I^\uparrow(\tau) - \tilde{\omega}(1-b)I^\uparrow(\tau) - \tilde{\omega}bI^\downarrow(\tau) \quad (5-53)$$

and

$$-\frac{1}{\sqrt{3}} \frac{dI^\downarrow(\tau)}{d\tau} = I^\downarrow(\tau) - \tilde{\omega}bI^\uparrow(\tau) - \tilde{\omega}(1-b)I^\downarrow(\tau) \quad (5-54)$$

in both of which

$$b = \frac{1}{2} \left(1 - \frac{\tilde{\omega}_1}{3}\right) \quad (5-55)$$

These are the S-P forms of the two-stream equations. We can further evaluate $\tilde{\omega}_1$ in terms of the more familiar asymmetry factor, g , which is the first moment of the phase function (see eqs. (1-46) and (1-47))

$$g = \frac{1}{2} \int_{-1}^1 \mu P(\mu) d\mu \quad (5-56)$$

and with equation (2-31) we get

$$\begin{aligned}
 g &= \frac{1}{2} \int_{-1}^1 \mu \sum_{j=0}^N \tilde{\omega}_j P_j(\mu) d\mu \\
 &= \frac{1}{2} \sum_{j=1}^N \tilde{\omega}_j \int_{-1}^1 \mu P_j(\mu) d\mu \\
 &= \frac{1}{2} \sum_{j=1}^N \tilde{\omega}_j \int_{-1}^1 P_1(\mu) P_j(\mu) d\mu = 0 \quad (j \neq 1) \\
 &= \frac{1}{2} \tilde{\omega}_1 \int_{-1}^1 \mu^2 d\mu = \frac{\tilde{\omega}_1}{3} \quad (j = 1) \quad (5-57)
 \end{aligned}$$

Hence, we can define b in the more familiar way

$$b = \frac{1}{2}(1 - g) \quad (5-58)$$

Coakley-Chylek (Coakley and Chylek, 1975). The C-C form of the two-stream equations is found directly from equations (5-4) and (5-6) simply by assuming that I^\uparrow and I^\downarrow are independent of μ , and using the definition of equation (5-21). This gives immediately the pair of equations

$$\mu \frac{dI^\uparrow(\tau)}{d\tau} = I^\uparrow(\tau) - \tilde{\omega}[1 - \beta(\mu)]I^\uparrow(\tau) - \tilde{\omega}\beta(\mu)I^\downarrow(\tau) \quad (5-59)$$

$$-\mu \frac{dI^\downarrow(\tau)}{d\tau} = I^\downarrow(\tau) - \tilde{\omega}\beta(\mu)I^\uparrow(\tau) - \tilde{\omega}[1 - \beta(\mu)]I^\downarrow(\tau) \quad (5-60)$$

Solution of the Two-Stream Equations

Comparison of equation (5-46) with equation (5-47), equation (5-53) with equation (5-54), and equation (5-59) with equation (5-60) shows that they all can be put into the same algebraic form

$$\mu_1 \frac{dI^\uparrow(\tau)}{d\tau} = I^\uparrow(\tau) - \tilde{\omega}(1 - \gamma)I^\uparrow(\tau) - \tilde{\omega}\gamma I^\downarrow(\tau) \quad (5-61)$$

$$-\mu_1 \frac{dI^\downarrow(\tau)}{d\tau} = I^\downarrow(\tau) - \tilde{\omega}\gamma I^\uparrow(\tau) - \tilde{\omega}(1-\gamma)I^\downarrow(\tau) \quad (5-62)$$

in which we have the correspondences recorded in table 5-3.

TABLE 5-3. COMPARISON BETWEEN μ_1 AND γ FOR THE THREE SOLUTION METHODS

Solution method	μ_1	γ
S-S	1/2	$\beta(\mu)$
S-P	$1/\sqrt{3}$	b
C-C	μ	$\beta(\mu)$

It is comforting to note that equations (5-61) and (5-62) satisfy our physical intuition. For example, let us look at equation (5-61) at some altitude. If we increase z to $z + dz$, then τ decreases by $d\tau$. If we write equation (5-61) in the form

$$\mu_1 \frac{dI^\uparrow(\tau)}{d\tau} = (1 - \tilde{\omega})I^\uparrow(\tau) + \tilde{\omega}\gamma I^\uparrow(\tau) - \tilde{\omega}\gamma I^\downarrow(\tau)$$

we see that $I^\uparrow(z + dz)$ is reduced by the first right-hand-side term, the absorption of the upward radiance between z and $z + dz$, as well as by the second right-hand-side term, the radiance backscattered out of the upward beam, and that it is increased by the last term, the part of the downward beam which is backscattered in the upward direction.

Equations (5-61) and (5-62) can be solved by any number of standard techniques. We select here the operator approach. Put equations (5-61) and (5-62) into the form

$$\left\{ \mu_1 \frac{d}{d\tau} - [1 - \tilde{\omega}(1 - \gamma)] \right\} I^\uparrow(\tau) = -\tilde{\omega}\gamma I^\downarrow(\tau) \quad (5-63)$$

$$\left\{ \mu_1 \frac{d}{d\tau} + [1 - \tilde{\omega}(1 - \gamma)] \right\} I^\downarrow(\tau) = \tilde{\omega}\gamma I^\uparrow(\tau) \quad (5-64)$$

Solve equation (5-64) for $I^\downarrow(\tau)$. Substitute into equation (5-63) and expand the operator to get

$$\left(\frac{d^2}{d\tau^2} - \xi^2 \right) I^\uparrow(\tau) = 0 \quad (5-65)$$

where

$$\xi^2 = \alpha^2 - \beta^2 \quad (5-66)$$

$$\alpha = \frac{1 - \tilde{\omega}(1 - \gamma)}{\mu_1} \quad (5-67)$$

$$\beta = \frac{\tilde{\omega}\gamma}{\mu_1} \quad (5-68)$$

Equation (5-65) then solves immediately as

$$I^\uparrow(\tau) = Ae^{\xi\tau} + Be^{-\xi\tau} \quad (5-69)$$

where A and B are constants of integration. Put equation (5-69) into equation (5-63) and solve for $I^\downarrow(\tau)$,

$$I^\downarrow(\tau) = Awe^{\xi\tau} + Bve^{-\xi\tau} \quad (5-70)$$

where

$$w = \frac{\alpha - \xi}{\beta} \quad (5-71)$$

and

$$v = \frac{\alpha + \xi}{\beta} \quad (5-72)$$

Finally, apply the boundary conditions

$$I^\downarrow(0) = I_0 \quad (5-73)$$

$$I^\uparrow(\tau^*) = 0 \quad (5-74)$$

where τ^* is the total optical thickness of the atmosphere. Solve the resulting expressions for A and B to give the intensity solutions in final form

$$I^\uparrow(\tau) = I_0 \left[\frac{e^{-\xi(\tau^* - \tau)} - e^{\xi(\tau^* - \tau)}}{we^{-\xi\tau^*} - ve^{\xi\tau^*}} \right] \quad (5-75)$$

$$I^\downarrow(\tau) = I_0 \left[\frac{we^{-\xi(\tau^* - \tau)} - ve^{\xi(\tau^* - \tau)}}{we^{-\xi\tau^*} - ve^{\xi\tau^*}} \right] \quad (5-76)$$

From these, the reflection and transmission functions are found to be

$$R = \frac{I^\uparrow(0)}{I_0} = \frac{e^{-\xi\tau^*} - e^{\xi\tau^*}}{we^{-\xi\tau^*} - ve^{\xi\tau^*}} \quad (5-77)$$

and

$$T = \frac{I^\downarrow(\tau^*)}{I_0} = \frac{w - v}{we^{-\xi\tau^*} - ve^{\xi\tau^*}} \quad (5-78)$$

Thus, if we for instance use the S-P parameters from table 5-3, the resulting expressions may be algebraically different from those of Sagan and Pollack (1967), but the results will be numerically identical to theirs.

Solution for conservative scattering, $\tilde{\omega} = 1$. The case of conservative scattering, $\tilde{\omega} = 1$, cannot be found directly from the solutions of equations (5-75) and (5-76) simply by setting $\tilde{\omega} = 1$, because $\xi = 0$ for $\tilde{\omega} = 1$, and the solution falls apart. The conservative scattering case must be gotten by starting with the differential equations (5-61) and (5-62) and setting $\tilde{\omega} = 1$

$$\mu_1 \frac{dI^\uparrow(\tau)}{d\tau} = \gamma I^\uparrow(\tau) - \gamma I^\downarrow(\tau) \quad (5-79)$$

$$-\mu_1 \frac{dI^\downarrow(\tau)}{d\tau} = \gamma I^\downarrow(\tau) - \gamma I^\uparrow(\tau) \quad (5-80)$$

The right-hand sides of these equations are identical and must, therefore, be constant

$$\gamma I^\uparrow(\tau) - \gamma I^\downarrow(\tau) = M \quad (5-81)$$

M is a constant. Equation (5-79) has the immediate solution

$$I^\uparrow(\tau) = \frac{M\tau}{\mu_1} + B \quad (5-82)$$

where B is again a constant of integration (not the same B as we just used earlier). Similarly, equation (5-80) gives

$$I^\downarrow(\tau) = \frac{M\tau}{\mu_1} + B' \quad (5-83)$$

Substitute equations (5-82) and (5-83) into equation (5-81) to evaluate the constant M . Since M is constant for all τ , it is most conveniently evaluated at $\tau = 0$. This gives

$$M = \gamma(B - B')$$

and equations (5-82) and (5-83) are rewritten as

$$I^\uparrow(\tau) = B \left(1 + \frac{\gamma\tau}{\mu_1} \right) - \frac{\gamma\tau}{\mu_1} B' \quad (5-84)$$

$$I^\downarrow(\tau) = \frac{\gamma\tau}{\mu_1} B + \left(1 - \frac{\gamma\tau}{\mu_1} \right) B' \quad (5-85)$$

The constants B and B' are evaluated from the boundary conditions of equations (5-73) and (5-74), and hence, the final solutions for the two-stream conservative scattering case can be written as

$$I^\uparrow(\tau) = I_0 \left[\frac{\frac{\gamma}{\mu_1}(\tau^* - \tau)}{1 + \frac{\gamma\tau^*}{\mu_1}} \right] \quad (5-86)$$

$$I^\downarrow(\tau) = I_0 \left[1 - \frac{\frac{\gamma\tau}{\mu_1}}{1 + \frac{\gamma\tau^*}{\mu_1}} \right] \quad (5-87)$$

The reflection and transmission functions become

$$R = \frac{I^\uparrow(0)}{I_0} = \frac{\frac{\gamma\tau^*}{\mu_1}}{1 + \frac{\gamma\tau^*}{\mu_1}} \quad (5-88)$$

$$T = \frac{I^\downarrow(\tau^*)}{I_0} = \frac{1}{1 + \frac{\gamma\tau^*}{\mu_1}} \quad (5-89)$$

Note in this case that $R + T = 1$, as there is no absorption in the case of conservative scattering. Also, in the limit as $\tau^* \rightarrow \infty$ for $\tilde{\omega} = 1$,

$$R(\tau^* \rightarrow \infty) = 1 \quad (\tilde{\omega} = 1)$$

$$T(\tau^* \rightarrow \infty) = 0 \quad (\tilde{\omega} = 1)$$

Since there is no absorption, all of the incoming radiation eventually escapes from the atmosphere ($R = 1$), and obviously, nothing passes through the infinite optical depth ($T = 0$).

The two-stream flux equations are simply obtained from the radiance solutions

$$F^\uparrow(\tau) = 2\pi \int_0^1 \mu I^\uparrow(\tau) d\mu = 2\pi\mu_1 I^\uparrow(\tau) \quad (5-90)$$

$$F^\downarrow(\tau) = 2\pi \int_0^1 \mu I^\downarrow(\tau) d\mu = 2\pi \mu_1 I^\downarrow(\tau) \quad (5-91)$$

Solution for diffuse component only. The two-stream solutions presented thus far have involved the total intensity—the diffuse plus the direct components. Liou (1980) presents a solution for the diffuse component only. The solution closely parallels the development given above, so just the barest outline will be given here. Start with equation (2-51) and evaluate the integral by the Gauss method:

$$\int_{-1}^1 f(x) dx \approx \sum_{j=-n}^n a_j f(x_j) \quad (5-92)$$

(e.g., Abramowitz and Stegun, 1970), where the weights

$$a_j = \frac{1}{P'_{2n}(x_j)} \int_{-1}^1 \frac{P_{2n}(x)}{x - x_j} dx$$

and the x_j are the zeros of the even-numbered Legendre polynomials. Also, we have

$$a_{-j} = a_j \quad x_{-j} = -x_j \quad \sum_{j=-n}^n a_j = 2$$

and thus can write equation (2-51) for a ray defined by μ_i as

$$\begin{aligned} \mu_i \frac{dI(\tau, \mu_i)}{d\tau} = & I(\tau, \mu_i) - \frac{\tilde{\omega}}{2} \sum_{\ell=0}^N \tilde{\omega}_\ell P_\ell(\mu) \sum_{j=-n}^n a_j P_\ell(\mu_i) I(\tau, \mu_j) \\ & - \frac{\tilde{\omega}}{4} F_0 \sum_{\ell=0}^N (-1)^\ell \tilde{\omega}_\ell P_\ell(\mu_i) P_\ell(-\mu_0) e^{-\tau/\mu_0} \end{aligned} \quad (5-93)$$

in which we have used the property of Legendre polynomials

$$P_n(-x) = (-1)^n P_n(x)$$

For the two-stream solution, we take $i = \pm 1$. Then since $\mu_1 = 3^{-1/2}$ and $a_1 = a_{-1}$ (Abramowitz and Stegun, 1970) we can break equation (5-93) into two equations

$$\begin{aligned} \mu_1 \frac{dI^\uparrow(\tau)}{d\tau} &= I^\uparrow(\tau) - \tilde{\omega}(1-b)I^\uparrow(\tau) - \tilde{\omega}bI^\downarrow(\tau) \\ &\quad - \frac{\tilde{\omega}}{4}F_0(1-3g\mu_0\mu_1)e^{-\tau/\mu_0} \end{aligned} \quad (5-94)$$

$$\begin{aligned} -\mu_1 \frac{dI^\downarrow(\tau)}{d\tau} &= I^\downarrow(\tau) - \tilde{\omega}(1-b)I^\downarrow(\tau) - \tilde{\omega}bI^\uparrow(\tau) \\ &\quad - \frac{\tilde{\omega}}{4}F_0(1+3g\mu_0\mu_1)e^{-\tau/\mu_0} \end{aligned} \quad (5-95)$$

Proceeding as before, writing equations (5-94) and (5-95) in operator notation, we find after some messy but straightforward algebra that

$$I^\uparrow(\tau) = Ave^{k\tau} + Bue^{-k\tau} + \epsilon e^{-\tau/\mu_0} \quad (5-96)$$

$$I^\downarrow(\tau) = Aue^{k\tau} + Bve^{-k\tau} + \lambda e^{-\tau/\mu_0} \quad (5-97)$$

where the following definitions hold:

$$u = \frac{1-a}{2} \quad v = \frac{1+a}{2} \quad \lambda = \frac{\alpha-\beta}{2} \quad \epsilon = \frac{\alpha+\beta}{2} \quad a^2 = \frac{1-\tilde{\omega}}{1-\tilde{\omega}g}$$

$$\alpha = \frac{z_1\mu_0^2}{1-k^2\mu_0^2} \quad \beta = \frac{z_2\mu_0^2}{1-k^2\mu_0^2} \quad k^2 = \frac{(1-\tilde{\omega}g)(1-\tilde{\omega})}{\mu_1^2}$$

$$z_1 = \frac{-(1-\tilde{\omega}g)(s^- + s^+)}{\mu_1^2} + \frac{(s^- - s^+)}{\mu_0\mu_1}$$

$$z_2 = \frac{-(1-\tilde{\omega})(s^- - s^+)}{\mu_1^2} + \frac{(s^- + s^+)}{\mu_0\mu_1}$$

$$s^\pm = \frac{\tilde{\omega}}{4}F_0(1 \pm 3g\mu_0\mu_1)$$

The application of the boundary conditions usually used with the diffuse component

$$I^\downarrow(0) = I^\uparrow(\tau^*) = 0$$

gives the constants

$$A = \frac{\epsilon v e^{-\tau^*/\mu_0} - \lambda u e^{-k\tau^*}}{u^2 e^{-k\tau^*} - v^2 e^{k\tau^*}}$$

$$B = \frac{\lambda v e^{k\tau^*} - \epsilon u e^{-\tau^*/\mu_0}}{u^2 e^{-k\tau^*} - v^2 e^{k\tau^*}}$$

With the fluxes determined from equations (5-90) and (5-91), the planetary albedo is given by equation (4-16) with the incoming colimated flux by equation (4-14). From these, after some algebraic reduction,

$$\begin{aligned} r(\mu_0) &= \frac{F^\uparrow(0)}{\pi F_0 \mu_0} \\ &= \frac{2\mu_1}{D} \left[(v^2 - u^2) \left(\frac{G_2 - G_1}{2} \right) e^{-\tau^*/\mu_0} \right. \\ &\quad \left. + uv \left(\frac{G_1 + G_2}{2} \right) (e^{-k\tau^*} - e^{k\tau^*}) \right] + 2\mu_1 \left(\frac{G_2 - G_1}{2} \right) \end{aligned} \quad (5-98)$$

in which

$$G_1 = \frac{\tilde{\omega} \mu_0}{1 - k^2 \mu_0^2} \left[\left(\frac{3}{2} \right) g + \frac{(1 - \tilde{\omega} g)}{2\mu_1^2} \right]$$

$$G_2 = \frac{\tilde{\omega}}{1 - k^2 \mu_0^2} \left[\frac{1}{2\mu_1} + \left(\frac{3}{2} \right) g \frac{\mu_0^2}{\mu_1} (1 - \tilde{\omega}) \right]$$

$$D = u^2 e^{-k\tau^*} - v^2 e^{k\tau^*}$$

The diffuse transmission coefficient can similarly be written as

$$\begin{aligned} t(\mu_0) &= \frac{F^\uparrow(\tau^*)}{\pi F_0 \mu_0} \\ &= \frac{2\mu_1}{D} \left\{ uv \left(\frac{G_2 - G_1}{2} \right) \left[e^{-\tau^* \left(\frac{1}{\mu_0} - k \right)} - e^{\tau^* \left(\frac{1}{\mu_0} + k \right)} \right] \right. \\ &\quad \left. + (u^2 - v^2) \left(\frac{G_2 + G_1}{2} \right) \right\} \\ &\quad - 2\mu_1 \left(\frac{G_2 + G_1}{2} \right) e^{-\tau^*/\mu_0} \end{aligned}$$

The total transmission coefficient, diffuse plus direct is, of course,

$$T(\mu_0) = t(\mu_0) + e^{-\tau^*/\mu_0} \quad (5-99)$$

If we consider the special case of an infinitely thick atmosphere, $\tau^* \rightarrow \infty$, we find that in the limit, the albedo of an infinitely thick atmosphere becomes

$$r(\mu_0) = 2\mu_1 \left[\left(\frac{G_2 - G_1}{2} \right) + \frac{u}{v} \left(\frac{G_2 + G_1}{2} \right) \right] \quad (5-100)$$

Note that this is not unity, as we found before for the conservative atmosphere case. Here, $\tilde{\omega} \neq 1$ and there is absorption present, so not all of the incident radiation escapes from the top of the atmosphere.

In the next chapter, results from equations (5-98) to (5-100) will be compared with those from the Eddington approximation.

The conservative solution, in which $\tilde{\omega} = 1$, also proceeds from equations (5-94) and (5-95)

$$\mu_1 \frac{dI^\uparrow(\tau)}{d\tau} = bI^\uparrow(\tau) - bI^\downarrow(\tau) - s^- e^{-\tau/\mu_0} \quad (5-101)$$

$$\mu_1 \frac{dI^\downarrow(\tau)}{d\tau} = bI^\uparrow(\tau) - bI^\downarrow(\tau) + s^+ e^{-\tau/\mu_0} \quad (5-102)$$

the solutions to which are

$$I^\uparrow(\tau) = B_1 \left(1 + \frac{b\tau}{\mu_1} \right) - B_2 \frac{b\tau}{\mu_1} + \alpha_1 F_0 e^{-\tau/\mu_0} \quad (5-103)$$

$$I^\downarrow(\tau) = B_1 \frac{b\tau}{\mu_1} + B_2 \left(1 - \frac{b\tau}{\mu_1} \right) + \beta_1 F_0 e^{-\tau/\mu_0} \quad (5-104)$$

in which

$$B_1 = \frac{-\left(\frac{\beta_1 F_0 b\tau^*}{\mu_1} + \alpha_1 F_0 e^{-\tau^*/\mu_0} \right)}{1 + \frac{b\tau^*}{\mu_1}}$$

$$B_2 = -\beta_1 F_0$$

and

$$\alpha_1 = \frac{1}{4} \frac{\mu_0}{\mu_1} \left(1 - 3g\mu_0\mu_1 - 2b\frac{\mu_0}{\mu_1} \right)$$

$$\beta_1 = -\frac{1}{4} \frac{\mu_0}{\mu_1} \left(1 + 3g\mu_0\mu_1 + 2b\frac{\mu_0}{\mu_1} \right)$$

The fluxes, as before, are given by equations (5-90) and (5-91). The upward flux at the top of the atmosphere is

$$F^\uparrow(0) = \frac{2\pi\mu_0\mu_1 F_0 \left[\frac{b\tau^*}{2\mu_1^2} + \frac{\alpha_1}{\mu_0} (1 - e^{-\tau^*/\mu_0}) \right]}{1 + \frac{b\tau^*}{\mu_1}} \quad (5-105)$$

and hence, the planetary albedo becomes

$$r(\mu_0) = \frac{\frac{b\tau^*}{\mu_1} + \frac{1}{2} \left(1 - 3g\mu_0\mu_1 - 2b\frac{\mu_0}{\mu_1} \right) (1 - e^{-\tau^*/\mu_0})}{1 + \frac{b\tau^*}{\mu_1}} \quad (5-106)$$

As it should, this also approaches 1 as τ^* becomes infinite.

Similarly, the downward flux at the surface, $\tau = \tau^*$, becomes

$$F^\downarrow(\tau^*) = 2\pi\mu_1 \left[B_1 \frac{b\tau^*}{\mu_1} + B_2 \left(1 - \frac{b\tau^*}{\mu_1} \right) + \beta_1 F_0 e^{-\tau^*/\mu_0} \right]$$

and since the scattering is conservative

$$t(\mu_0) = 1 - r(\mu_0) \quad (5-107)$$

from which the diffuse transmission function can be found.

There is a very interesting extension of the Schuster two-stream method to n streams in a paper by Acquista, House, and Jafolla (1981). No azimuthal symmetry is assumed, and instead of just considering an upper and a lower hemisphere, as done above, the authors break each hemisphere into an arbitrary number of nonoverlapping patches and compute the radiance stream for each patch. No numerical data are presented, but it is reasonably claimed that computational costs are substantially less than for other more nearly exact methods for a given accuracy, and great flexibility in the choice of patches is claimed, for minimizing computational costs for particular applications.

Chapter 6

The Eddington Solution

The basic differential equations describing the Eddington approximation are derived somewhat differently from those of the two-stream solutions. However, the mathematical technique leading to the solution is quite similar, and hence, will not be given in the same detail as in the preceding chapter.

The Eddington solution begins by assuming that the intensity, instead of being approximated by different upward and downward constants, can be approximated by a *linear* function of μ of the form

$$I(\tau, \mu) = I_0(\tau) + \mu I_1(\tau) \quad (6-1)$$

where I_0 and I_1 are functions of τ only, and not of μ . Now, if we apply the same two-stream approximation to equation (2-51), i.e., let $N = 1$, we get

$$\begin{aligned} \mu \frac{dI(\tau, \mu)}{d\tau} = & I(\tau, \mu) - \frac{\tilde{\omega}}{2} \left[\tilde{\omega}_0 P_0(\mu) \int_{-1}^1 P_0(\mu') I(\tau, \mu') d\mu' \right. \\ & \left. + \tilde{\omega}_1 P_1(\mu) \int_{-1}^1 P_1(\mu') I(\tau, \mu') d\mu' \right] \\ & - \frac{\tilde{\omega}}{4} F_0 e^{-\tau/\mu_0} [\tilde{\omega}_0 P_0(\mu) P_0(-\mu_0) + \tilde{\omega}_1 P_1(\mu) P_1(-\mu_0)] \end{aligned}$$

or

$$\begin{aligned} \mu \frac{dI(\tau, \mu)}{d\tau} = & I(\tau, \mu) - \frac{\tilde{\omega}}{2} \left[\int_{-1}^1 I(\tau, \mu') d\mu' + \tilde{\omega}_1 \mu \int_{-1}^1 \mu' I(\tau, \mu') d\mu' \right] \\ & - \frac{\tilde{\omega}}{4} F_0 e^{-\tau/\mu_0} (1 - \tilde{\omega}_1 \mu \mu_0) \end{aligned} \quad (6-2)$$

which is identical to assuming a two-term expansion of the phase function directly in equation (2-50)

$$P(\mu, \mu') \approx 1 + \tilde{\omega}_1 \mu \mu'$$

The Eddington method for solving the RTE also leads to a two-stream type of solution, but as indicated earlier, and discussed in detail below, begins in a completely different manner. It will be seen that the *intensity* boundary conditions cannot be completely satisfied at either surface, although the *flux* boundary conditions can be at least formally, if not exactly, physically satisfied. For this reason, the Eddington solution is more accurate for very thick optical depths. It also uses a two-term expansion for the phase function, resulting in a solution that is most accurate for scattering, which is close to isotropic. This occurs well inside an optically thick atmosphere, after multiple scatterings have taken place (see Irvine, 1968). Multiple scattering deep in the interior effectively smooths out the phase function in that the sharp maxima and minima usually present in the phase function disappear, and the scattering becomes more nearly isotropic.

The integrals in equation (6-2) can be evaluated with the use of the Eddington assumption, equation (6-1)

$$\int_{-1}^1 I(\tau, \mu') d\mu' = 2I_0(\tau)$$

$$\int_{-1}^1 \mu' I(\tau, \mu') d\mu' = \frac{2}{3}I_1(\tau)$$

and with equation (5-57), equation (6-2) can be written as

$$\begin{aligned} \mu \frac{d}{d\tau} [I_0(\tau) + \mu I_1(\tau)] = & I_0(\tau) + \mu I_1(\tau) - \tilde{\omega} [I_0(\tau) + g\mu I_1(\tau)] \\ & - \frac{\tilde{\omega}}{4} F_0 e^{-\tau/\mu_0} (1 - 3g\mu\mu_0) \end{aligned} \quad (6-3)$$

Equation (6-3) can be broken up into two equations for $I_1(\tau)$ and $I_0(\tau)$ as follows: multiply equation (6-3) by $d\mu$ and integrate from -1 to $+1$.

$$\frac{dI_1(\tau)}{d\tau} = 3(1 - \tilde{\omega})I_0(\tau) - \frac{3}{4}\tilde{\omega}F_0e^{-\tau/\mu_0} \quad (6-4)$$

Now, multiply equation (6-3) by $\mu d\mu$ and integrate over the same limits

$$\frac{dI_0(\tau)}{d\tau} = (1 - \tilde{\omega}g)I_1(\tau) + \frac{3}{4}\tilde{\omega}F_0g\mu_0e^{-\tau/\mu_0} \quad (6-5)$$

We now again have two coupled linear ordinary differential equations with constant coefficients. These are solved the same way as for the

two-stream solution, and give

$$I_0(\tau) = Ae^{k\tau} + Be^{-k\tau} + \alpha e^{-\tau/\mu_0} \quad (6-6)$$

$$I_1(\tau) = aAe^{k\tau} - aBe^{-k\tau} + \beta e^{-\tau/\mu_0} \quad (6-7)$$

in which the following definitions hold

$$a^2 = \frac{3(1-\tilde{\omega})}{1-\tilde{\omega}g}$$

$$\alpha = -\frac{3}{4}\tilde{\omega}F_0 \left(\frac{G_0\mu_0^2}{1-k^2\mu_0^2} \right), \beta = \frac{3}{4}\tilde{\omega}F_0 \left(\frac{G_1\mu_0^2}{1-k^2\mu_0^2} \right)$$

$$k^2 = 3(1-\tilde{\omega})(1-\tilde{\omega}g)$$

and

$$G_0 = 1 - \tilde{\omega}g + g$$

$$G_1 = 3(1-\tilde{\omega})g\mu_0 + \frac{1}{\mu_0}$$

Note that here we cannot apply the boundary conditions

$$I^\downarrow(0) = 0, I^\uparrow(\tau^*) = 0$$

since to do so would result in two equations in four unknowns. The reason for this is that equation (6-1) is really the first two terms of a Legendre polynomial expansion for the radiance, $I(\tau, \mu)$

$$I(\tau, \mu) = I_0(\tau)P_0(\mu) + I_1(\tau)P_1(\mu)$$

and we cannot depict a *constant* function (constant zero flux at all entry angles μ_0) with only a two-term expansion. However, we can at least formally apply the boundary conditions to the *flux* form of the solution. Using equation (6-1) in the flux definition

$$F^\uparrow(\tau) = 2\pi \int_0^1 \mu I(\tau, \mu) d\mu = \pi \left[I_0(\tau) + \frac{2}{3}I_1(\tau) \right] \quad (6-8)$$

$$F^\downarrow(\tau) = 2\pi \int_{-1}^0 \mu I(\tau, \mu) d\mu = \pi \left[I_0(\tau) - \frac{2}{3}I_1(\tau) \right] \quad (6-9)$$

Insert equations (6-6) and (6-7) into equations (6-8) and (6-9)

$$F^\uparrow(\tau) = A\alpha e^{k\tau} + B\alpha e^{-k\tau} + \epsilon e^{-\tau/\mu_0} \quad (6-10)$$

$$F^\downarrow(\tau) = Aue^{k\tau} + Bve^{-k\tau} + \gamma e^{-\tau/\mu_0} \quad (6-11)$$

where

$$v = \pi \left(1 + \frac{2}{3}a \right)$$

$$u = \pi \left(1 - \frac{2}{3}a \right)$$

$$\epsilon = \pi \left(\alpha + \frac{2}{3}\beta \right)$$

$$\gamma = \pi \left(\alpha - \frac{2}{3}\beta \right)$$

Then, from the *flux* boundary conditions

$$F^\downarrow(\tau^*) = 0 \quad F^\downarrow(0) = 0$$

$$A = \frac{v\epsilon e^{-\tau^*/\mu_0} - \gamma u e^{-k\tau^*}}{u^2 e^{-k\tau^*} - v^2 e^{k\tau^*}}$$

$$B = \frac{v\gamma e^{-k\tau^*} - u\epsilon e^{-\tau^*/\mu_0}}{u^2 e^{-k\tau^*} - v^2 e^{k\tau^*}}$$

Just as we did in chapter 5 for the two-stream case, we can write the reflection and diffuse transmission coefficients for the Eddington solution as

$$r(\mu_0) = \frac{1}{D} \left[L_1 (v^2 - u^2) e^{-\tau^*/\mu_0} - L_2 uv (e^{-k\tau^*} - e^{+k\tau^*}) \right] + L_1 \quad (6-12)$$

$$t(\mu_0) = \frac{1}{D} \left[L_2 (v^2 - u^2) + L_1 uv \left(e^{-\tau^* (\frac{1}{\mu_0} - k)} - e^{-\tau^* (\frac{1}{\mu_0} + k)} \right) \right] + L_2 e^{-\tau^*/\mu_0} \quad (6-13)$$

where

$$L_1 = \frac{\tilde{\omega}}{2} \left[\frac{3(1 - \tilde{\omega})g\mu_0^2 + 1 - \frac{3}{2}(1 - \tilde{\omega}g + g)\mu_0}{1 - k^2\mu_0^2} \right]$$

$$L_2 = \frac{\tilde{\omega}}{2} \left[\frac{3(1 - \tilde{\omega})g\mu_0^2 + 1 + \frac{3}{2}(1 - \tilde{\omega}g + g)\mu_0}{1 - k^2\mu_0^2} \right]$$

$$D = u^2 e^{-k\tau^*} - v^2 e^{k\tau^*}$$

For a semi-infinite atmosphere

$$r(\mu_0) = \frac{L_1 v - L_2 u}{v} \quad (6-14)$$

The case of conservative scattering, $\tilde{\omega} = 1$, must again be handled separately. Start with equations (6-4) and (6-5) and set $\tilde{\omega} = 1$

$$\frac{dI_1(\tau)}{d\tau} = -\frac{3}{4}F_0 e^{-\tau/\mu_0} \quad (6-15)$$

and

$$\frac{dI_0(\tau)}{d\tau} = (1-g)I_1(\tau) + \frac{3}{4}F_0 g \mu_0 e^{-\tau/\mu_0} \quad (6-16)$$

Equation (6-15) immediately integrates to

$$I_1(\tau) = \frac{3}{4}F_0 \mu_0 e^{-\tau/\mu_0} + K \quad (6-17)$$

where K is a constant of integration. Substituting equation (6-17) into equation (6-16), and integrating, yields

$$I_0(\tau) = -\frac{3}{4}F_0 \mu_0^2 e^{-\tau/\mu_0} + (1-g)K\tau + H \quad (6-18)$$

where H is another constant of integration.

If now equations (6-17) and (6-18) are put into the flux equations (6-8) and (6-9), and the same boundary conditions are applied, we get finally

$$H = \frac{F_0 \mu_0}{2} \left(1 + \frac{3}{2}\mu_0\right) + \frac{2}{3}K \quad (6-19)$$

with

$$K = \frac{-\frac{3}{2}F_0 \mu_0 \left[1 + \frac{3}{2}\mu_0 + \left(1 - \frac{3}{2}\mu_0\right) e^{-\tau^*/\mu_0}\right]}{3(1-g)\tau^* + 4} \quad (6-20)$$

From these results, the albedo for conservative scattering in the Eddington approximation becomes

$$r(\mu_0) = 1 - \frac{2L(\tau^*, \mu_0)}{3(1-g)\tau^* + 4} \quad (6-21)$$

where

$$L(\tau^*, \mu_0) = 1 + \frac{3}{2}\mu_0 + \left(1 - \frac{3}{2}\mu_0\right) e^{-\tau^*/\mu_0} \quad (6-22)$$

Two-Stream and Eddington Solutions for Semi-Infinite Atmospheres

For an infinitely thick atmosphere, $\tau^* \rightarrow \infty$, the two-stream albedo is given by equation (5-100) and the Eddington solution by equation (6-14).

The two-stream and Eddington solutions for a semi-infinite atmosphere are compared in figure 6-1. (The figure also shows other solutions—including the delta-Eddington which is discussed below.) The particular numerical values were selected to permit comparison with numerical results in Irvine (1968). We can see that, in general, the agreement is quite good, with the Eddington albedo being slightly lower than that given by the two-stream solution in all cases. For an excellent discussion of the relative accuracy of these two methods, compared with some exact results, see the review article by Irvine and Lenoble (1973).

The Delta-Eddington Method

Possibly the most challenging problem to be faced in radiative transfer theory is how to handle very asymmetric phase functions. Neither the simple two-stream approximation nor the Eddington solution can adequately cope with a phase function with a sharply scattered forward peak, which is the type usually encountered in aerosol and cloud studies.

The delta-Eddington method was devised by Joseph, Wiscombe, and Weinman (1976) to allow the computationally simple Eddington method to be applied to sharply peaked forward-scattered phase functions. They approximate the phase function by a Dirac delta to account for a portion of the forward peak, and a two-term expansion for the rest of the phase function. The two-term expansion of $P(\cos \theta)$ follows from equation (2-31) as

$$P(\cos \theta) \approx 1 + \tilde{\omega}_1 P_1(\cos \theta)$$

and with the definition of the asymmetry factor g of equation (5-57) this becomes

$$P(\cos \theta) = 1 + 3g P_1(\cos \theta)$$

The delta-Eddington phase function can now be written as

$$P(\cos \theta) = 2f\delta(1 - \cos \theta) + (1 - f)(1 + 3g \cos \theta) \quad (6-23)$$



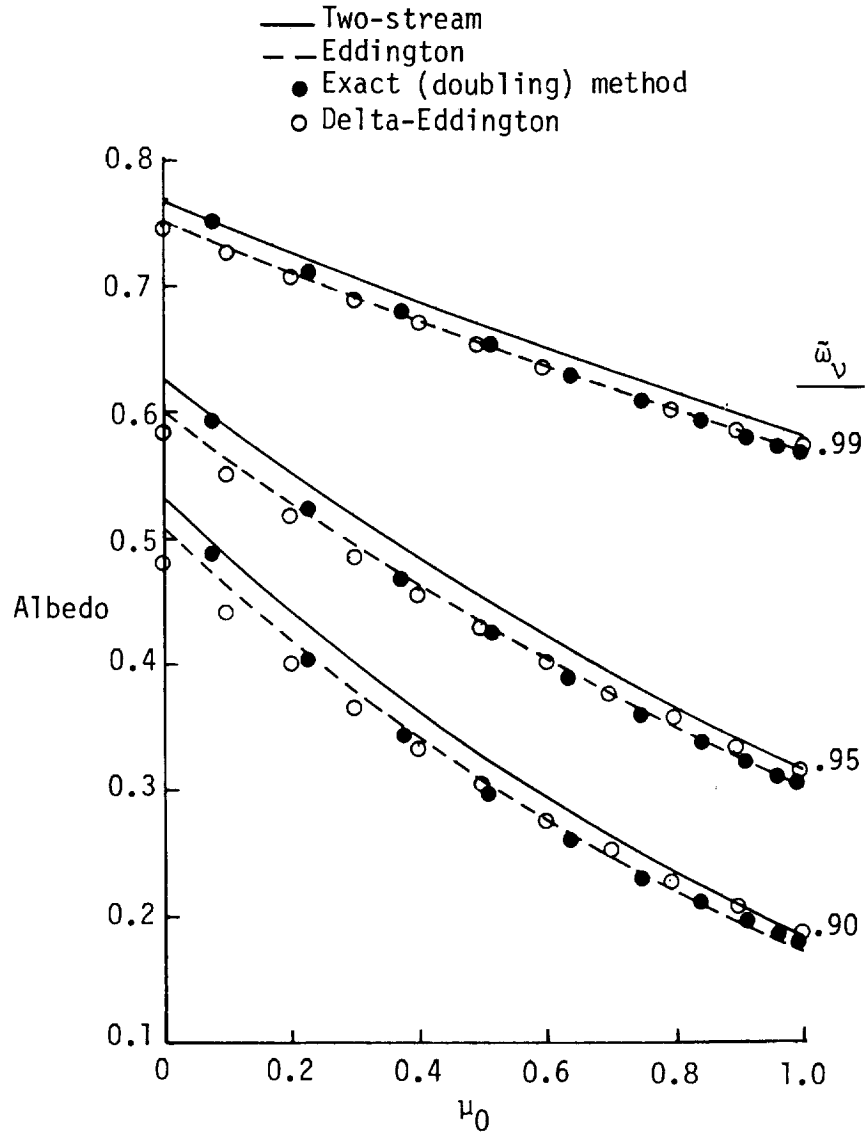

Figure 6-1. Comparison among four methods for a semi-infinite atmosphere. The dark circles are for the exact (doubling) method. Heney-Greenstein phase function with $g = 0.5$.

where f is the fraction of the radiation scattered into the forward peak. The azimuthal averaging of the phase function follows as

$$\bar{P}(\mu, \mu') = \frac{1}{2\pi} \int_0^{2\pi} P(\cos \theta) d\phi \quad (6-24)$$

and using equation (1-33) with

$$\delta(1 - \cos \theta) = 2\pi \delta(\mu - \mu') \delta(\phi - \phi')$$

we write equation (6-24) as

$$\bar{P}(\mu, \mu') = 2f\delta(\mu - \mu') + (1 - f)(1 + 3g\mu\mu') \quad (6-25)$$

Now, from the azimuthally averaged form of the RTE, equation (2-41)

$$\begin{aligned} \mu \frac{dI(\tau, \mu)}{d\tau} - I(\tau, \mu) &= \frac{\tilde{\omega}}{2} \int_{-1}^1 2f\delta(\mu - \mu') I(\tau, \mu') d\mu' \\ &\quad + \frac{\tilde{\omega}}{2} \int_{-1}^1 (1 - f)(1 + 3g\mu\mu') I(\tau, \mu') d\mu' \\ &= \tilde{\omega}fI(\tau, \mu) + \frac{\tilde{\omega}(1 - f)}{2} \int_{-1}^1 (1 + 3g\mu\mu') I(\tau, \mu') d\mu' \end{aligned}$$

which can be rearranged to give

$$\mu \frac{dI(\tau, \mu)}{(1 - \tilde{\omega}f) d\tau} - I(\tau, \mu) = \frac{\tilde{\omega}}{2} \int_{-1}^1 \frac{(1 - f)}{1 - \tilde{\omega}f} (1 + 3g\mu\mu') I(\tau, \mu') d\mu' \quad (6-26)$$

But this is precisely the form of the RTE, equation (6-2), if we define

$$\tau' = (1 - \tilde{\omega}f)\tau \quad (6-27)$$

and

$$\tilde{\omega}' = \frac{(1 - f)\tilde{\omega}}{1 - \tilde{\omega}f} \quad (6-28)$$

Joseph et al. also show that for the delta-Eddington phase function to have the same asymmetry factor as the original phase function (the one we are trying to approximate), then

$$g = f + (1 - f)g'$$

or

$$g' = \frac{g - f}{1 - f} \quad (6-29)$$

Finally, if the Henyey-Greenstein phase function is used, which does indeed produce reasonable results for many applications, they show that

$$f = g^2 \quad (6-30)$$

and hence, equation (6-29) becomes

$$g' = \frac{g}{1 + g} \quad (6-31)$$

Thus, the same equations derived earlier for the Eddington solution may be used if we replace $\tilde{\omega}$, τ , and g with $\tilde{\omega}'$, τ' , and g' .

Comparison of Two-Stream and Eddington Results

The two-stream, Eddington, and delta-Eddington solutions are compared with the exact (doubling) method (Liou, 1980) in figures 6-2 to 6-5, for the case of conservative scattering ($\tilde{\omega} = 1$) and one case of nonconservative scattering ($\tilde{\omega} = 0.8$) for two optical depths, $\tau^* = 4.0$ and $\tau^* = 0.25$, with $g = 0.25$ used in both cases. The superiority of the delta-Eddington method is clearly evident, especially at the more nearly vertical incident angles ($\mu \approx 1.0$).

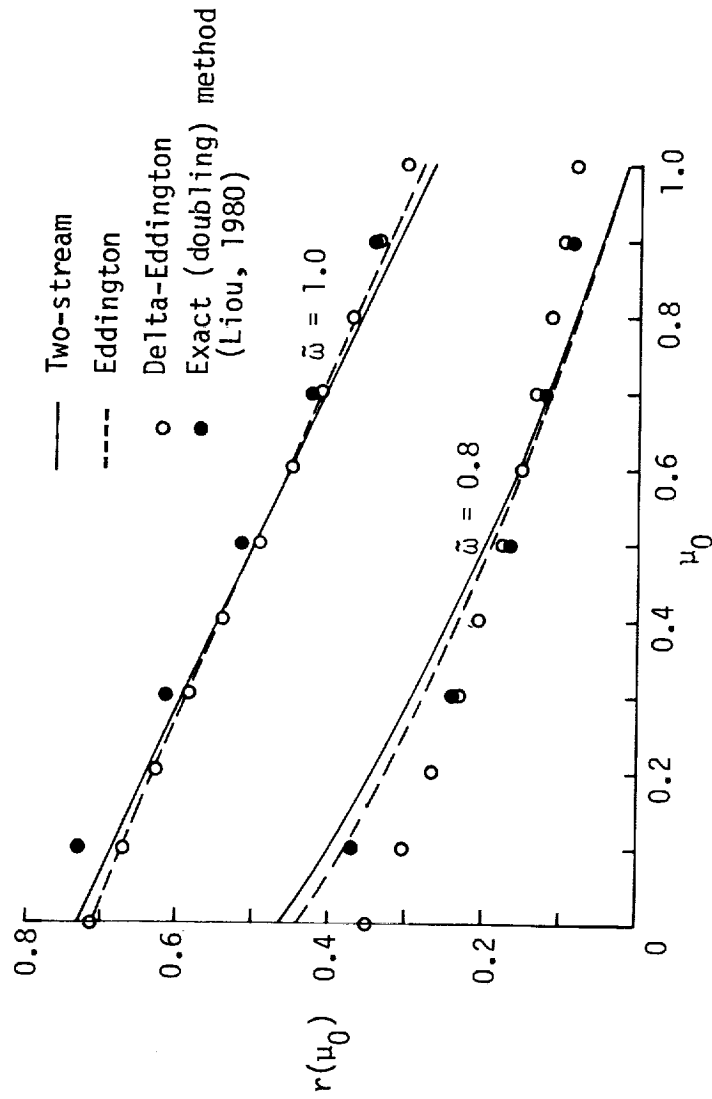

Figure 6-2. Comparison of the two-stream, Eddington, and delta-Eddington methods for a finite atmosphere. The dark circles are for the exact (doubling) method. (Heney-Greenstein phase function with $\tau^* = 4.0$ and $g = 0.25$.)

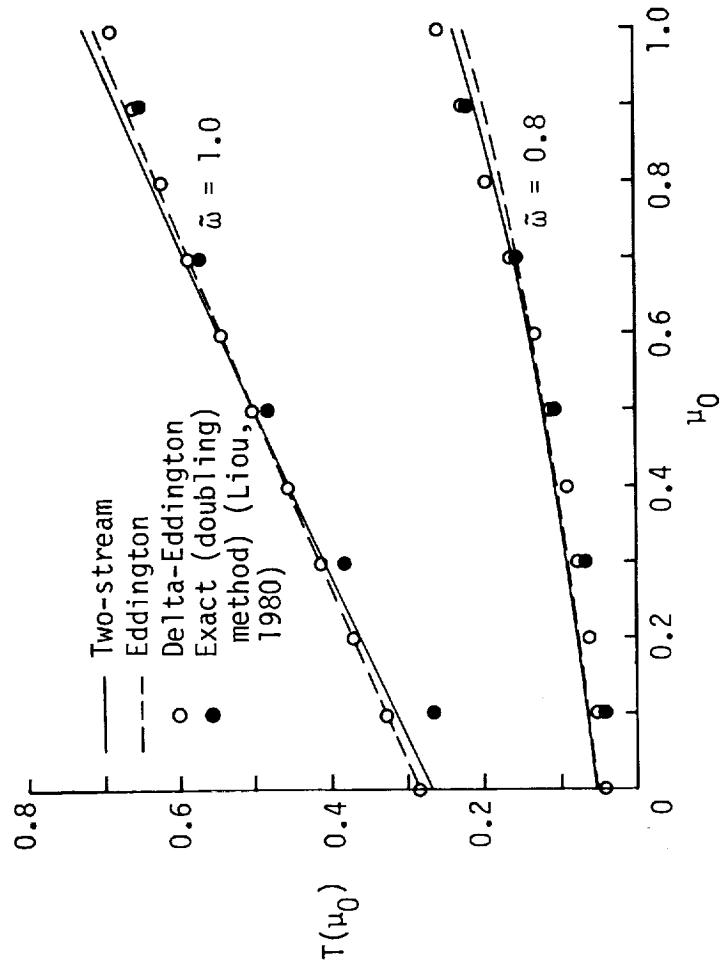

Figure 6-3. Total transmission coefficient for same case as figure 6-2.

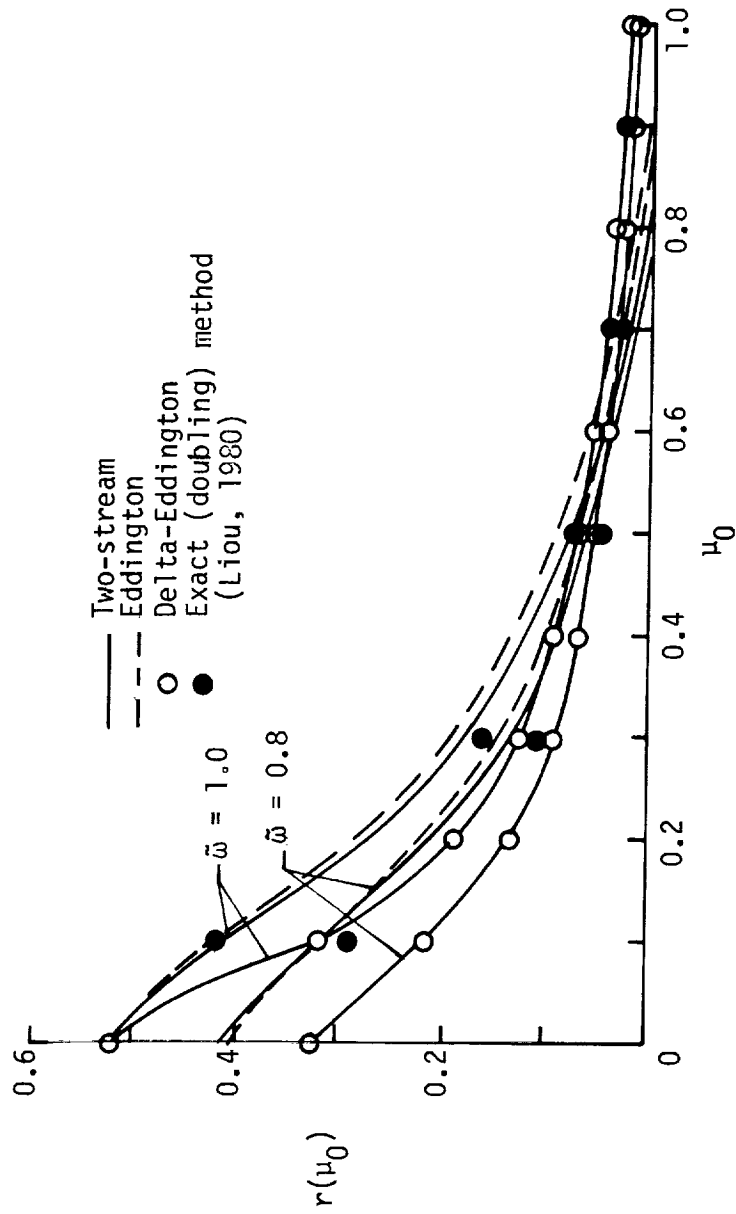

Figure 6-4. Comparison of the two-stream, Eddington, and delta-Eddington methods for a finite atmosphere. The dark circles are for the exact (doubling) method. (Henye-Greenstein phase function with $\tau^* = 0.25$ and $g = 0.25$.)

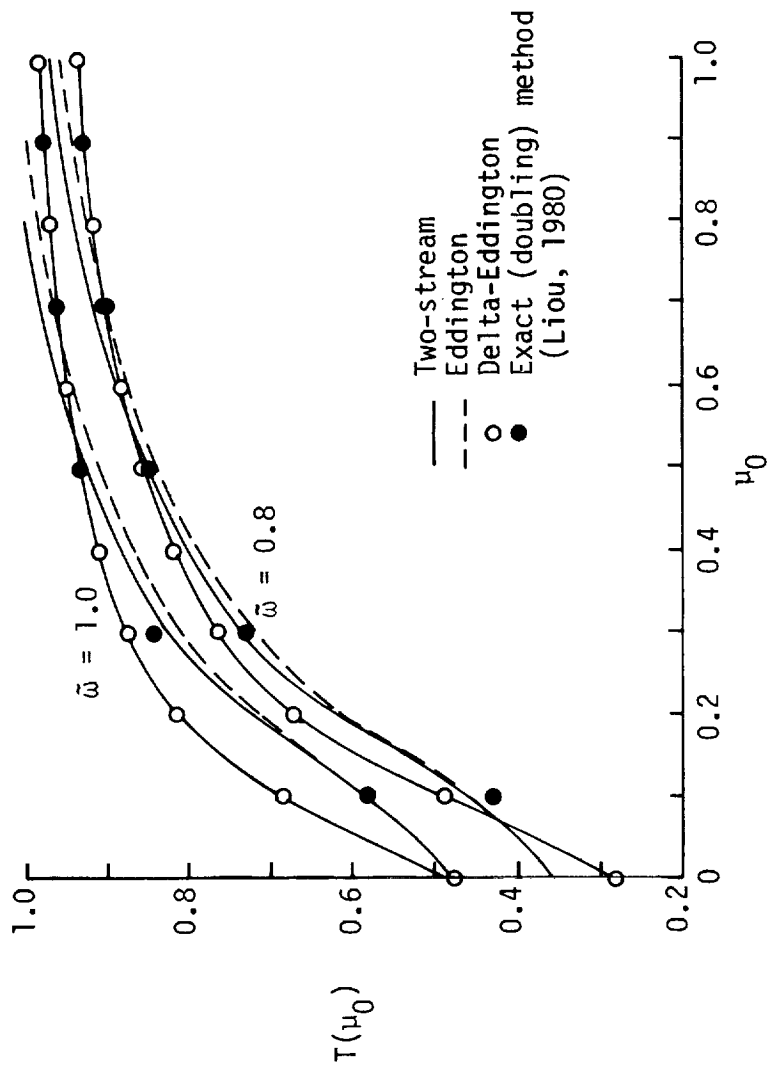

Figure 6-5. Total transmission coefficient for same case as figure 6-4.



Chapter 7

Discrete Ordinates Method

The discrete ordinates method is a very powerful analytic approach to solving the RTE. This method was developed by, or at least perfected and popularized by, Chandrasekhar. The procedure can be used to extract numerical results for the simpler forms of the phase function, and has been used for numerical studies of nonhomogeneous atmospheres.

Its greatest utility, however, seems to be a starting point for many theoretical attacks on the RTE. The theory has been developed to a very high degree of sophistication, and for that reason, it is worth spending some detailed effort in introducing this approach. The mathematics appears formidable at first glance, but once the reader gets into it, it emerges much simpler than imagined.

The analysis here is confined to homogeneous semi-infinite atmospheres, and is carried far enough to permit the introduction of the well-known H -function of Chandrasekhar. The *principle of invariance* for semi-infinite atmospheres is introduced and the integral-equation formulation of the H -function derived. The zeroth and first-order solutions to the integral equation are also derived, and some numerical results are given for higher-order approximations. Finally, some elementary applications are presented.

The extension to finite atmospheres is not given here, as it would be far beyond the intended scope of these notes. However, once the semi-infinite atmosphere case is understood, the reader will have little difficulty extrapolating to the finite atmosphere development, and the X - and Y -functions, which are the finite atmosphere analogues to the H -function, will no longer seem quite so formidable or incomprehensible.

The analysis to be presented here follows chapter 3 of Chandrasekhar very closely, and merely supplies some of the missing steps in his development, although his text is so well written that it is difficult, even within the confines of the present supplement, to improve on it much. The analysis is restricted to two cases: (1) conservative isotropic scattering, and (2) nonconservative isotropic scattering. Again, his

results for nonisotropic scattering can easily be followed once the isotropic case is understood.

To repeat something stated earlier, the isotropic case should not be dismissed lightly. As discussed in Irvine and Lenoble (1973) and Sobolev (1975), it is possible to develop *similarity relations* which can be used in some cases to approximately reduce an anisotropic scatter problem to an equivalent isotropic one. These relations allow an equivalent isotropic optical depth and single-scatter albedo to be defined in terms of the real anisotropic parameters. The isotropic problem is then solved and the solution transformed back to the "real" problem space. Similarity relations will be discussed briefly at the end of the chapter.

Gaussian Integration

We first present a few identities derived from Gaussian integration, as some of these results are needed in later developments.

Basically, the integral of a continuous function is replaced by a finite sum

$$\int_{-1}^1 f(x) dx \approx \sum_{j=-m}^m a_j f(x_j) \quad (7-1)$$

where the weights a_j are given by

$$a_j = \frac{1}{P'_m(x_j)} \int_{-1}^1 \frac{P_m(x)}{x - x_j} dx \quad (7-2)$$

and the ordinates x_j are the zeros of the Legendre polynomials, $P_m(x)$. For our present needs, it is convenient to restrict ourselves to the zeros of the even-numbered polynomials, $P_{2m}(x)$. (See the discussion in Chandrasekhar for more details as to why this is so.) For these divisions

$$a_i = a_{-i}, x_{-i} = -x_i \quad (7-3)$$

For the case in which $f(x) = x^m$ we get

$$\begin{aligned} \int_{-1}^1 x^m dx &= \frac{2}{m+1} && \text{(for } m \text{ even)} \\ &= 0 && \text{(for } m \text{ odd)} \end{aligned}$$

Then, since

$$\int_{-1}^1 x^m dx = \sum_{j=-n}^n a_j x_j^m$$

$$\sum_{j=-n}^n a_j x_j^m = \frac{2}{m+1} \quad (\text{for } m \text{ even}) \quad (7-4)$$

$$= 0 \quad (\text{for } m \text{ odd})$$

Abramowitz and Stegun (1970) give tables of a_j and x_j for a number of orders n . See Chandrasekhar, or any good text on numerical methods, for more details of the Gaussian method.

RTE for Conservative, Isotropic Scattering

The governing equation for this problem is equation (2-41), with $\tilde{\omega} = 1$ and $P(\cos\theta) = 1$

$$\mu \frac{dI(\tau, \mu)}{d\tau} = I(\tau, \mu) - \frac{1}{2} \int_{-1}^1 I(\tau, \mu') d\mu' \quad (7-5)$$

Replace the integral with the Gaussian approximation and evaluate equation (7-5) at each of the $2n$ streams defined by the Gaussian quadrature points (see fig. 7-1).

$$\mu_i \frac{dI_i}{d\tau} = I_i - \frac{1}{2} \sum_{j=-n}^n a_j I_j \quad (7-6)$$

Thus, equation (7-6) becomes a system of $2n$ linear equations with constant coefficients. As usual with systems of differential equations of this type, assume a set of exponential solutions

$$I_i = g_i e^{-k\tau} \quad (i = 1, 2, \dots, n) \quad (7-7)$$

where the g_i are unknown constant coefficients. Substitute equation (7-7) into equation (7-6) and reduce

$$g_i(1 + \mu_i k) = \frac{1}{2} \sum_{j=-n}^n a_j g_j \quad (7-8)$$

Now, even though we do not know what the numerical values of the g_i are, they are *constants*, and the right-hand side of equation (7-8) directs us to sum over *all* these constants. Thus, the right-hand side of equation (7-8) is also a constant, K , and therefore, the g_i must be of the form

$$g_i = \frac{K}{1 + \mu_i k} \quad (7-9)$$

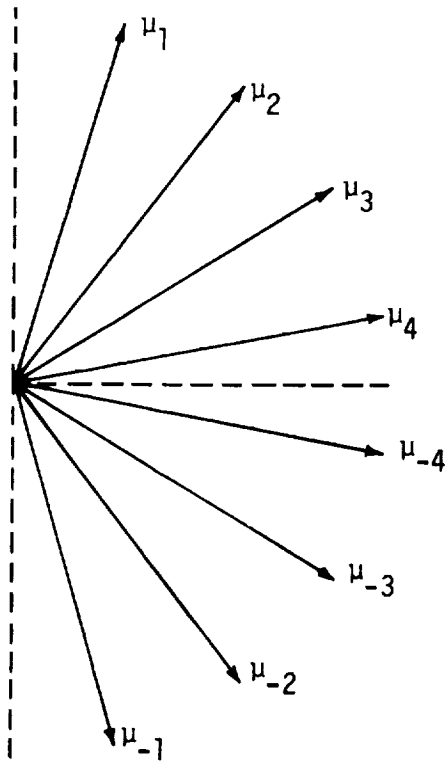

Figure 7-1. Sketch showing the ray directions for the $n = 4$ case discussed in the text as the running numerical example.

If we substitute equation (7-9) back into equation (7-8), we get

$$\frac{1}{2} \sum_{j=-n}^n \frac{a_j}{1 + \mu_j k} = 1 \quad (7-10)$$

Now, the limits on the sum are from $-n$ to $+n$. We can use equation (7-3) to simplify equation (7-10) and write it in a neater form. If we expand equation (7-10) and look at the $j = m$ term

$$1 = \frac{1}{2} \left[\dots + \frac{a_{-m}}{1 + \mu_m k} + \dots + \frac{a_m}{1 - \mu_m k} + \dots \right]$$

Since each j produces a pair of terms like this, we can write, using equation (7-3)

$$1 = \frac{1}{2} \left[\cdots + \frac{2a_m}{1 - \mu_m^2 k^2} + \cdots \right]$$

so that we can write equation (7-10) as

$$\sum_{j=1}^n \frac{a_j}{1 - \mu_j^2 k^2} = 1 \quad (7-11)$$

This is the characteristic equation for the equation set (7-6), from which we can get the $2n$ eigenvalues, k_α . Equation (7-11) is of degree n in k_α^2 , and, thus, it can be seen that the eigenvalues occur in pairs, $\pm k_\alpha$. For $k^2 = 0$, we have from equation (7-11)

$$\sum_{j=1}^n a_j = 1$$

while equation (7-4) gives, for $m = 0$

$$\sum_{j=-n}^n a_j = 2 \Rightarrow \sum_{j=1}^n a_j = 1$$

and hence, $k^2 = 0$, or $k = 0$ is also a double root of equation (7-11). Note that this results from the assumed conservative scattering.

Note that equation (7-11) has n vertical asymptotes (see, for example, fig. 7-2)—namely those values that occur at $k = 1/\mu_i$. If we write

$$F(k) = \sum_{j=1}^n \frac{a_j}{1 - \mu_j^2 k^2} - 1$$

we see that $F(0) = 0$, and for $k \ll 1$, $F(k) > 0$. Also,

$$\lim_{k \rightarrow 0} F(k) = -1$$

Thus, $F(k)$ plots as shown in figure 7-2, where we have used $n = 4$ as an example. (The 4-point Gaussian example will be carried throughout this chapter.) Since $\mu (= \cos \theta) \leq 1$, the eigenvalues are positive, with one root at $k = 0$. The roots can be found by the Newton-Raphson method

$$k_{n+1} = k_n - \frac{F(k_n)}{F'(k_n)} \quad (7-12)$$

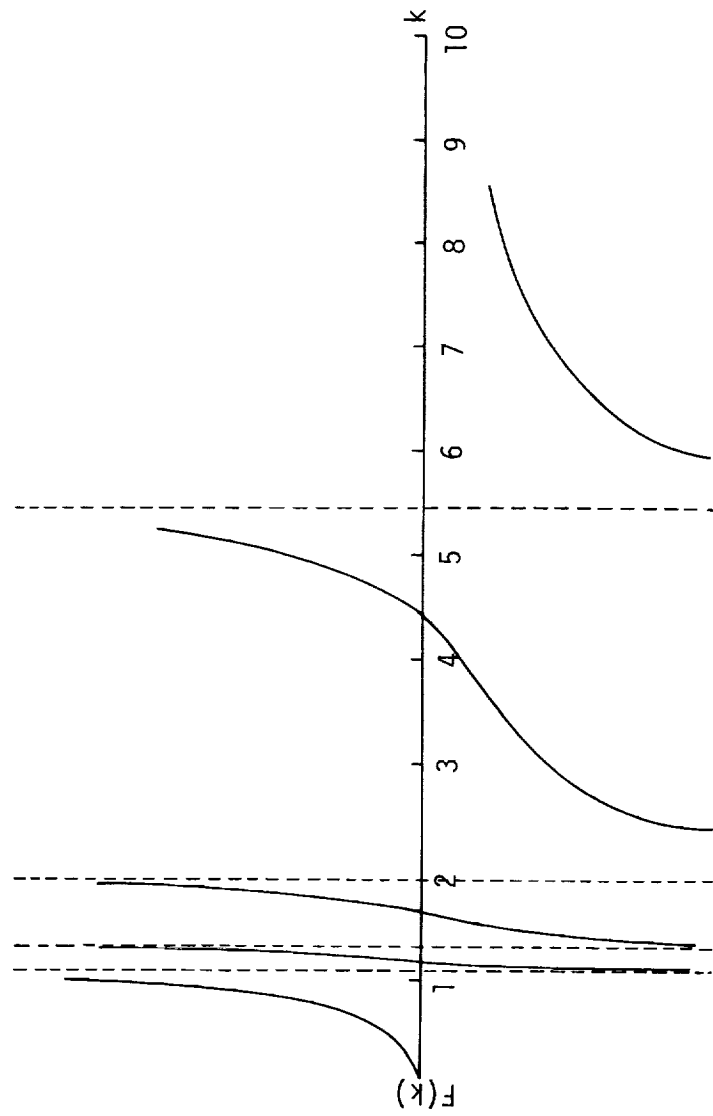

Figure 7-2. $F(k)$ vs. k for the $n = 4$ case. The asymptotes occur at $k = 1/\mu_4$ and the eigenvalues at $F(k) = 0$.

where the starting values can be taken as $(1/\mu + \epsilon)$, where ϵ is some small number.

For $n = 4$ (4-point Gaussian quadrature), Abramowitz and Stegun (1970) give the following:

$$\begin{aligned} \mu_1 &= 0.1834346425 & a_1 &= 0.3626837834 \\ \mu_2 &= 0.5255324099 & a_2 &= 0.3137066459 \\ \mu_3 &= 0.7966664774 & a_3 &= 0.2223810345 \\ \mu_4 &= 0.9602898565 & a_4 &= 0.1012285363 \end{aligned}$$

Using equation (7-12), we get the roots in table 7-1.

TABLE 7-1. ROOTS FROM EQUATION (7-12)

α	k_α
0	0.
1	1.103185321
2	1.591778876
3	4.458085719

With the k_α now given, equation (7-7) gives the complete solution for I_i as

$$I_i = \sum_{\alpha=1}^{n-1} \left(\frac{L_\alpha e^{-k_\alpha \tau}}{1 + \mu_i k_\alpha} \right) + \sum_{\alpha=1}^{n-1} \left(\frac{L_{-\alpha} e^{k_\alpha \tau}}{1 - \mu_i k_\alpha} \right) \quad (7-13)$$

where L_α and $L_{-\alpha}$ are constants of integration.

But, we have not yet included the $k = 0$ root. Guided by the grey Eddington solution (see e.g., Kourganoff, 1963), we assume for I_i the solution

$$I_i = b(\tau + q_i) \quad (7-14)$$

with b and q_i constants. Substitute equation (7-14) into equation (7-6)

$$\mu_i = q_i - \frac{1}{2} \sum_{j=-n}^n a_j q_j \quad (7-15)$$

and these equations can be satisfied if we let

$$q_i = Q + \mu_i \quad (7-16)$$

where Q is another constant. Thus, with equation (7-13), the complete solution to equation (7-5) is

$$I_i = b \left[\sum_{\alpha=1}^{n-1} \left(\frac{L_{\alpha} e^{-k_{\alpha} \tau}}{1 + \mu_i k_{\alpha}} \right) + \sum_{\alpha=1}^{n-1} \left(\frac{L_{-\alpha} e^{k_{\alpha} \tau}}{1 - \mu_i k_{\alpha}} \right) + \tau + \mu_i + Q \right] \quad (7-17)$$

In equation (7-17), the b , Q , and $L_{\pm\alpha}$ ($\alpha = 1, 2, \dots, n-1$) are the $2n$ constants of integration.

We can eliminate some of these immediately. The radiance should not, of course, become infinite as $\tau \rightarrow \infty$. Thus, all the $L_{-\alpha}$ must vanish, and equation (7-17) reduces to

$$I_i = b \left[\sum_{\alpha=1}^{n-1} \left(\frac{L_{\alpha} e^{-k_{\alpha} \tau}}{1 + \mu_i k_{\alpha}} \right) + \tau + \mu_i + Q \right] \quad (7-18)$$

One relation among the remaining constants can be found by applying the boundary condition that the incoming diffuse radiation at the top of the atmosphere ($\tau = 0$) be zero for all the $-\mu_i$. This gives, for equation (7-18),

$$0 = \sum_{\alpha=1}^{n-1} \frac{L_{\alpha}}{1 + \mu_i k_{\alpha}} - \mu_i + Q \quad (7-19)$$

Equation (7-19) gives n equations in n unknowns, Q and $n-1$ values of L_{α} . The constant b is not as yet found—it is left arbitrary for now. Thus, of the $2n$ original constants of integration, $n-1$ are found to be zero by the requirement that I_i remain finite as $\tau \rightarrow \infty$, n are found from equation (7-19), and b is as yet unknown.

Somewhat later in his text, Chandrasekhar goes to great lengths to develop a direct and simple way to determine numerical values for the constants L_{α} and Q —probably because at the time his original text was written, there were no efficient and accurate methods for inverting large matrices or for solving large systems of linear equations. With modern computers and numerical techniques, these sophisticated algebraic methods are no longer needed and will not be developed in these notes. Instead, we will solve directly the system of equation (7-19).

For the 4-point Gaussian example, equation (7-19) gives the system of equations

$$\begin{aligned} 1.253703L_1 + 1.412414L_2 + 5.487454L_3 + Q &= 0.1834346 \\ 2.379598L_1 + 6.117365L_2 - 0.744676L_3 + Q &= 0.5255324 \\ 8.255792L_1 - 3.729726L_2 - 0.391910L_3 + Q &= 0.7966655 \\ -16.840604L_1 - 1.891903L_2 - 0.304781L_3 + Q &= 0.9602899 \end{aligned}$$

The solution to these equations gives

$$\begin{aligned} L_1 &= -0.009461126 \\ L_2 &= -0.036186730 \\ L_3 &= -0.083921097 \\ Q &= 0.706919484 \end{aligned}$$

(The values in Chandrasekhar are inadvertently given in reverse order. A note found in Kourganoff, 1963, p. 104, points out this reversal.)

Some Elementary Identities

Note that the solution of equation (7-18) contains a term similar to

$$\sum_{\alpha=1}^{n-1} \frac{1}{1 + \mu_i k_\alpha}$$

It will be convenient to generalize this to a *continuous* function, and define the moments

$$D_m(x) = \sum_i \frac{a_i \mu_i^m}{1 + \mu_i x} \quad (7-20)$$

We can derive a recursion formula for $D_m(x)$

$$\begin{aligned} D_{m-1}(x) &= \sum_i \frac{a_i \mu_i^{m-1}}{1 + \mu_i x} = \sum_i a_i \mu_i^{m-1} \left(1 - \frac{\mu_i x}{1 + \mu_i x} \right) \\ &= \sum_i a_i \mu_i^{m-1} - \sum_i \frac{a_i \mu_i^m x}{1 + \mu_i x} \end{aligned}$$

But by equation (7-4)

$$\sum_i a_i \mu_i^{m-1} = \frac{2\delta}{m} \quad (\delta = 0 \text{ for } m \text{ even})$$

$$(\delta = 1 \text{ for } m \text{ odd})$$

hence

$$D_{m-1}(x) = \frac{2\delta}{m} - x \sum_i \frac{a_i \mu_i^m}{1 + \mu_i x} = \frac{2\delta}{m} - x D_m(x)$$

or

$$D_m(x) = \frac{1}{x} \left[\frac{2\delta}{m} - D_{m-1}(x) \right] \quad (7-21)$$

is the required recursion equation. Thus we get, for m odd

$$D_{2j-1}(x) = \frac{1}{x} \left[\frac{2}{2j-1} - D_{2j-2}(x) \right] \quad (7-22)$$

and for m even

$$D_{2j}(x) = \frac{-1}{x} D_{2j-1}(x) \quad (7-23)$$

By comparing equation (7-20), with $m = 0$, to equation (7-10)

$$D_0(x_j) = \sum_{j=-n}^n \frac{a_j}{1 + \mu_j x_j} = 2 \quad (7-24)$$

and, thus, from equations (7-22) and (7-23) we get the sequence

$$\begin{aligned} D_0(x) &= 2 \\ D_1(x) &= 0 \\ D_2(x) &= 0 \\ D_3(x) &= \frac{2}{3x} \\ &\vdots \end{aligned}$$

By repeated application of equations (7-22) and (7-23), with the above, it is possible to establish the general formulas (see Chandrasekhar), since k is a root of the characteristic equation.

$$D_{2j-1}(k) = \frac{2}{(2j-1)k} + \frac{2}{(2j-3)k^2} + \cdots + \frac{2}{3k^{2j-3}} \quad (7-25)$$

$$D_{2j}(k) = \frac{-2}{(2j-1)k^2} - \frac{2}{(2j-3)k^4} - \dots - \frac{2}{3k^{2j-2}} \quad (7-26)$$

where $j = 2, 3, \dots, n$.

The even Legendre polynomials can always be written in the form

$$P_{2n}(\mu) = \sum_{j=0}^n p_{2j} \mu^{2j} \quad (7-27)$$

where the p_{2j} are constant coefficients.

Consider the expansion

$$\begin{aligned} \sum_{j=0}^n p_{2j} D_{2j}(k) &= \sum_{i=0}^m p_{2i} \sum_{j=-n}^n \frac{a_j \mu_j^{2i}}{1 + \mu_i k} \\ &= \sum_{j=-n}^n \frac{a_j}{1 + \mu_k k} \sum_{i=0}^m p_{2i} \mu_j^{2i} \\ &= \sum_{j=-n}^n \frac{a_j}{1 + \mu_j k} \sum_{i=0}^m P_{2i}(\mu_j) \end{aligned}$$

But, by the Gaussian quadrature procedure we have adopted, the μ_j are zeros of the even-numbered Legendre polynomials. Hence, the right-hand side of the above equation is equal to zero, and we have

$$\sum_{j=0}^n p_{2j} D_{2j}(k) = 0 \quad (7-28)$$

From this Chandrasekhar derives an equation which is used in several places in the remaining development

$$(k_1, k_2, \dots, k_{n-1})(\mu_1, \mu_2, \dots, \mu_n) = \frac{1}{\sqrt{3}} \quad (7-29)$$

(Note the different ranges on the subscripts of equation (7-29).)

The Flux Equation

The flux is defined as before, for azimuthally symmetric radiation

$$F(\tau) = 2\pi \int_{-1}^1 \mu I(\tau, \mu) d\mu$$

Or, in the Gaussian approximation

$$F(\tau) = 2\pi \sum_{j=-n}^n a_j I_j \mu_j \quad (7-30)$$

If we substitute the solution (7-18) into equation (7-30)

$$F(\tau) = 2\pi b \left[\sum_{\alpha=1}^{n-1} L_\alpha e^{-k_\alpha \tau} \sum_{i=-n}^n \frac{a_i \mu_i}{1 + \mu_i k_\alpha} + (\tau + Q) \sum_{i=-n}^n a_i \mu_i + \sum_{i=-n}^n a_i \mu_i^2 \right]$$

From the definitions of $D_m(x)$ in equation (7-20) this becomes

$$F(\tau) = 2\pi b \left[\sum_{\alpha=1}^{n-1} L_\alpha e^{-k_\alpha \tau} D_1(k_\alpha) + (\tau + Q) \sum_{i=-n}^n a_i \mu_i + \sum_{i=-n}^n a_i \mu_i^2 \right]$$

But $D_1(k_\alpha) = 0$, and from equation (7-4)

$$\sum_i a_i \mu_i = 0$$

$$\sum_i a_i \mu_i^2 = \frac{2}{3}$$

and thus we get

$$F(\tau) = \frac{4}{3} \pi b \quad (7-31)$$

Since b is a constant, this equation says that the flux is constant at all τ —which is indeed true for this problem. (Since we have considered the equilibrium problem of conservative scattering in a semi-infinite atmosphere, the net flux *in* must equal the net flux *out*, and the net flux is conserved at all altitudes because there is no absorption or emission.) Equation (7-31) allows us now to evaluate the constant b

$$b = \frac{3}{4} \pi F$$

and, hence, this establishes our final constant of integration. The solution of equation (7-18) becomes

$$I_i = \frac{3}{4} \pi F \left[\sum_{\alpha=1}^{n-1} \left(\frac{L_\alpha e^{-k_\alpha \tau}}{1 + \mu_i k_\alpha} \right) + \tau + \mu_i + Q \right] \quad (7-32)$$

in which all the constants are now known.

The Source Function

From differential equation (7-5), the source function for this problem is written in the Gaussian quadrature form

$$J = \frac{1}{2} \int_{-1}^1 I(\tau, \mu) d\mu \approx \frac{1}{2} \sum_{i=-n}^n a_i I_i \quad (7-33)$$

Insert the solution equation (7-32) into equation (7-33) and proceed as in the F -integral; i.e., interchange orders of summation and use the $D_M(x)$ definitions, and we find that J reduces to

$$J = \frac{3}{4} \pi F \left(\sum_{\alpha=1}^{n-1} L_\alpha e^{-k_\alpha \tau} + \tau + Q \right) \quad (7-34)$$

Following Chandrasekhar, define

$$q(\tau) = \sum_{\alpha=1}^{n-1} L_\alpha e^{-k_\alpha \tau} + Q \quad (7-35)$$

and we can write the source function in the Eddington form

$$J = \frac{3}{4} \pi F [\tau + q(\tau)] \quad (7-36)$$

Inserting our numerical values in equation (7-35), we get

$$q(\tau) = 0.706919 - 0.009461 \exp(-1.103188\tau) - 0.036187 \exp(-1.591778\tau) \\ - 0.83921 \exp(-4.45808\tau)$$

See table 7-2.

Given the source function, we can now use equations (3-5) and (3-6) to get the intensity at *any* τ, μ (assuming, of course, the same boundary conditions and symmetry in $\mu = -\mu$). Thus, we write equations (3-5) and (3-6) as

$$I(\tau, \mu) = \int_{\tau}^{\infty} J(t) e^{-(t-\tau)/\mu} \frac{dt}{\mu}$$

$$I(\tau, -\mu) = \int_0^\tau J(t) e^{-(\tau-t)/\mu} \frac{dt}{\mu}$$

Substitution of equation (7-34) into the above and integrating poses no major problems. The results are

$$I(\tau, \mu) = \frac{3}{4} \pi F \left(\sum_{\alpha=1}^{n-1} L_\alpha \frac{e^{-k_\alpha \tau}}{1 + k_\alpha \mu} + \tau + \mu + Q \right) \quad (7-37)$$

$$I(\tau, -\mu) = \frac{3}{4} \pi F \left[\sum_{\alpha=1}^{n-1} \frac{L_\alpha}{1 - k_\alpha \mu} (e^{-k_\alpha \tau} - e^{-\tau/\mu}) + \tau + (Q - \mu)(1 - e^{-\tau/\mu}) \right] \quad (7-38)$$

TABLE 7-2. VALUES OF $q(\tau)$ FROM EQUATION (7-35)

τ	$q(\tau)$
0.	0.577350
0.1	0.613849
1.0	0.695441
3.0	0.706268
5.0	0.706868
10.0	0.706919
∞	Q

These are the final forms for the upward and downward radiance components in the n th approximation. Note that this is the intensity in direction μ based on a $2n$ -stream approximation for the source function.

The Law of Darkening

By putting $\tau = 0$ in equation (7-37), we get the angular distribution of the radiation emerging from the top of the atmosphere; i.e., the *law of darkening* or the *limb darkening equation*

$$I(0, \mu) = \frac{3}{4} \pi F \left(\sum_{\alpha=1}^{n-1} \frac{L_\alpha}{1 + k_\alpha \mu} + \mu + Q \right) \quad (7-39)$$

From our numerical example, we get

$$\frac{I(0, \mu)}{\pi F} = \frac{3}{4} \left[\frac{-0.009461}{1 + 1.103188\mu} - \frac{0.036187}{1 + 1.159178\mu} - \frac{0.083921}{1 + 4.458080\mu} + \mu + 0.706919 \right]$$

TABLE 7-3. VALUES FROM EQUATION (7-39)

μ	$\frac{I(0,\mu)}{\pi F}$	$\frac{I(0,\mu)}{I(0,1)}$
0.0	0.433013	0.345082
0.1	0.531852	0.423850
0.2	0.620516	0.494509
0.3	0.704562	0.561488
0.4	0.786070	0.626444
0.5	0.866012	0.690152
0.6	0.944910	0.753029
0.7	1.023094	0.815321
0.8	1.100699	0.877182
0.9	1.177915	0.938718
1.0	1.254812	1.0

See table 7-3.

Compare equation (7-18), a set of equations with a discrete argument, μ_i , with the parenthetically enclosed term of equation (7-39), which is a continuous function of μ . These are identical in form, except for the sign of the μ . As a lead-in to the H -functions, we define the *continuous* function

$$S(\mu) = \sum_{\alpha=1}^{n-1} \frac{L_{\alpha}}{1 - k_{\alpha}\mu} - \mu + Q \quad (7-40)$$

From this, we can write the boundary conditions (7-19) as

$$S(\mu_i) = 0 \quad (i = 1, 2, \dots, n) \quad (7-41)$$

and the law of darkening, equation (7-39), can be put into the form

$$I(0, \mu) = \frac{3}{4} \pi F S(-\mu) \quad (7-42)$$

a form which will be found to be more useful after we have derived the H -function. Note that the quantity $3\pi S(-\mu)/4$ can be to some extent interpreted from equation (7-42) as a diffuse reflection coefficient; i.e., it gives the angular distribution of the reflected radiance in terms of the incoming flux, F .

The H -Functions

Note from the definition of equation (7-40) that the S -function is defined in terms of the L_α and Q . These must in turn be obtained by solving a set of linear equations, equation (7-19). Knowledge of the L_α and Q permits us to determine the intensity and flux components at any point within the atmosphere. However, in many cases we are not concerned about the detailed structure of the radiation field *inside* the medium, but really need to know only what comes out of the top and/or what comes out of the bottom of the atmosphere. Chandrasekhar presents a method for doing just this, and this analysis leads to the definition of the H -functions, a set of functions which, for a given phase function, can be computed once and for all and tabulated. Note carefully the distinction between emission and scattering in the following development. Equation (7-51) expresses emission in terms of the H -function, while equation (7-84) expresses scattering in terms of the H -function with two different arguments. We proceed now with this derivation.

The summation in equation (7-40) contains the expression $(1 - k_\alpha\mu)$ in the denominator of each term. If we define the function

$$R(\mu) = \prod_{\alpha=1}^{n-1} (1 - k_\alpha\mu) \quad (7-43)$$

then, by multiplying $S(\mu)$ by $R(\mu)$, we get a function which is clear of fractions.

$$S(\mu)R(\mu) = \prod_{\alpha=1}^{n-1} (1 - k_\alpha\mu) \left(\sum_{\alpha=1}^{n-1} \frac{L_\alpha}{1 - k_\alpha\mu} - \mu + Q \right) \quad (7-44)$$

Since $R(\mu)$ is a polynomial of degree $(n - 1)$ in μ , the presence of the μ -term in the parentheses of equation (7-44) means that the product $S(\mu)R(\mu)$ is a polynomial of degree n in μ . Also notice that $S(\mu)R(\mu)$ vanishes for $\mu = \mu_i, i = 1, 2, \dots, n$, since by equation (7-41) S vanishes for these values.

Define the polynomial

$$P(\mu) = \prod_{i=1}^n (\mu - \mu_i) \quad (7-45)$$

which is also a polynomial of degree n in μ . Since $P(\mu)$ and $S(\mu)R(\mu)$ are both of degree n in μ , and have the same roots, μ_i , they can differ from each other by, at most, a multiplicative constant; i.e.,

$$S(\mu)R(\mu) = KP(\mu) \quad (7-46)$$

The constant K can be determined by comparing any power of μ on both sides of equation (7-46). In this case, it is easiest to compare coefficients of the highest power; i.e., of μ^n . From equation (7-44), it can be seen that the coefficient of μ^n on the left-hand side is

$$(-1)^n k_1 k_2 \dots k_{n-1}$$

while the coefficient of μ^n on the right-hand side is unity. Thus

$$K = (-1)^n k_1 k_2 \dots k_{n-1}$$

and hence, from equation (7-46)

$$S(\mu) = (-1)^n k_1 k_2 \dots k_{n-1} \frac{P(\mu)}{R(\mu)} \quad (7-47)$$

With the definition equations (7-43) and (7-45), and equation (7-29), this can all be put into the form (changing the sign of μ)

$$S(-\mu) = \frac{1}{\sqrt{3}} \frac{1}{\mu_1 \mu_2 \dots \mu_n} \frac{\prod_{i=1}^n (\mu + \mu_i)}{\prod_{\alpha=1}^{n-1} (1 + k_\alpha \mu)} \quad (7-48)$$

which now only contains the discrete coordinates, μ_i , and the eigenvalues, k_α , of the original system of equations. From equation (7-48) comes the discrete form of the definition of the H -function

$$H(\mu) = \frac{1}{\mu_1 \mu_2 \dots \mu_n} \frac{\prod_{i=1}^n (\mu + \mu_i)}{\prod_{\alpha=1}^{n-1} (1 + k_\alpha \mu)} \quad (7-49)$$

The equation (7-48) can be written

$$S(-\mu) = \frac{1}{\sqrt{3}}H(\mu) \quad (7-50)$$

and the law of darkening, equation (7-42), becomes

$$I(0, \mu) = \frac{\sqrt{3}}{4}\pi FH(\mu) \quad (7-51)$$

For our numerical example, in which $n = 4$, we get from equation (7-49)

$$H(\mu) = \frac{1}{0.073749} \left[\frac{(\mu + 0.18343)(\mu + 0.52553)(\mu + 0.79667)(\mu + 0.96029)}{(1 + 1.10319\mu)(1 + 1.59178\mu)(1 + 4.45808\mu)} \right]$$

See table 7-4.

TABLE 7-4. VALUES FROM EQUATION (7-49)

μ	$H(\mu)_{n=4}$	$H(\mu)_{\text{exact}}$
0.0	1.000000	1.0000
0.1	1.228240	1.2474
0.2	1.433003	1.4503
0.3	1.627100	1.6425
0.4	1.815335	1.8293
0.5	1.999953	2.0128
0.6	2.182162	2.1941
0.7	2.362674	2.3740
0.8	2.541940	2.5527
0.9	2.720262	2.7306
1.0	2.897849	2.9078

The exact solutions were computed from an integral equation to be developed later. It can be seen, however, that the fourth-order solution is not too bad, considering the relatively simple arithmetic involved.

As mentioned earlier, Chandrasekhar goes to great lengths to develop expressions similar to equation (7-47) for the constants L_α and Q . These derivations will not be repeated here, for reasons already

stated, but his results will be given for completeness and reference. Define the polynomial

$$R_\alpha(\mu) = \prod_{\substack{\beta=1 \\ \beta \neq \alpha}}^{n-1} (1 - k_\beta \mu) \quad (7-52)$$

Then the constants L_α and Q can be found without having to invert any matrices, from the relations

$$L_\alpha = (-1)^n k_1 k_2 \dots k_{n-1} \frac{P(1/k_\alpha)}{R_\alpha(1/k_\alpha)} \quad (7-53)$$

with $P(x)$ given by equation (7-45), and

$$Q = \sum_{i=1}^n \mu_i - \sum_{\alpha=1}^{n-1} \frac{1}{k_\alpha} \quad (7-54)$$

From our numerical example, we get

$$P(1/k_1) = -0.00162775$$

$$P(1/k_2) = 0.00255488$$

$$P(1/k_3) = -0.00518676$$

$$R_1(1/k_1) = 1.346865$$

$$R_2(1/k_2) = -0.552715$$

$$R_3(1/k_3) = 0.483843$$

We also get $k_1 k_2 k_3 = 7.828524$. Then, using equations (7-53) and (7-54) we get

$$L_1 = -0.0094611411$$

$$L_2 = -0.0361860937$$

$$L_3 = -0.0839211267$$

$$Q = 0.70691923070$$

which can be compared with the values found earlier, following equation (7-19), by inverting a 4- by 4-matrix.

Chandrasekhar also derives an accuracy check

$$Q + \sum_{\alpha=1}^{n-1} L_\alpha = \frac{1}{\sqrt{3}} \quad (7-55)$$

and, using our numerical data, we get for the left-hand side 0.5773508692 compared with the exact value of 0.5773502692.

So far, we have achieved a number of significant goals:

1. We have completely solved the simple case of the radiant field for which the net flux is constant, and a conservative, isotropic scattering medium.
2. We have gotten some numerical values—in the fourth-order approximation—for some of our expressions. These do not seem quite so frightening any more.
3. We have developed some basic concepts and ideas which will be of more use later on—specifically the S - and H -functions.
4. We have solved the limb darkening case for this simple problem.

Now, we consider a somewhat more difficult and useful problem.

Diffuse Radiation With Non-Conservative, Isotropic Scattering

We will now consider the problem of the scattering of a collimated beam into a semi-infinite atmosphere; i.e., the scattering of sunlight by a planetary atmosphere. Our starting equation is equation (2-50), which, for isotropic scattering, becomes

$$\mu \frac{dI(\tau, \mu)}{d\tau} = I(\tau, \mu) - \frac{\tilde{\omega}}{2} \int_{-1}^1 I(\tau, \mu) d\mu - \frac{\pi}{4} \tilde{\omega} F e^{-(\tau/\mu_0)} \quad (7-56)$$

Here, $\tilde{\omega}$ is the single-scattering albedo, and it is assumed that a parallel beam of solar radiation of flux F is hitting the top of the atmosphere at the angle $\theta_0 = \cos^{-1} \mu_0$.

The development given here will be somewhat sketchier than that in the earlier part of this chapter, as they are very similar and should not now pose any difficulty.

Again we discretize the integral and solve equation (7-56) along the discrete rays defined by μ_i ,

$$\mu_i \frac{dI_i}{d\tau} = I_i - \frac{1}{2} \tilde{\omega} \sum_{j=-n}^n I_j a_j - \frac{\pi}{4} \tilde{\omega} F e^{-\tau/\mu_0} \quad (i = \pm 1, \pm 2, \dots, \pm n) \quad (7-57)$$

We first solve the homogeneous system

$$\mu_i \frac{dI_i}{d\tau} = I_i - \frac{1}{2} \tilde{\omega} \sum_{j=-n}^n a_j I_j \quad (7-58)$$

by assuming, as before,

$$I_i = g_i e^{-kt}$$

If we put this into equation (7-58) and reduce, we get the characteristic equation for this problem

$$\tilde{\omega} \sum_{j=1}^n \frac{a_j}{1 - \mu_j^2 k^2} = 1 \quad (7-59)$$

This is identical to equation (7-11), except for the presence of the $\tilde{\omega}$. But this is a big "except," for now there are no roots at $k = 0$, and it will not now be necessary to introduce the somewhat artificial solution (7-14) into the system. The complete solution follows directly.

The asymptotes of equation (7-59) occur at the same place as those of equation (7-11), but the roots are somewhat larger, depending on the value of $\tilde{\omega}$, since

$$\sum_{i=1}^n \frac{a_j}{1 - \mu_i^2 k^2} = \frac{1}{\tilde{\omega}} \geq 1$$

The roots of equation (7-59) can be found for any $\tilde{\omega}$ in the same way as before. For the $n = 4$ case the data are as in table 7-5.

TABLE 7-5. ROOTS OF EQUATION (7-59)

$\tilde{\omega}$	$\alpha = 1$	$\alpha = 2$	$\alpha = 3$	$\alpha = 4$
1.0	0.	1.103186	1.591779	4.458086
0.9	0.525430	1.108937	1.615640	4.554851
0.8	0.710413	1.116799	1.642629	4.652965
0.7	0.828671	1.127655	1.672473	4.752078
0.6	0.907693	1.142395	1.704602	4.851871
0.5	0.959481	1.160900	1.738275	4.952060
0.4	0.992327	1.181880	1.772515	5.052401
0.3	1.012963	1.203057	1.806656	5.152683
0.2	1.026230	1.222732	1.840027	5.252727
0.1	1.035120	1.240155	1.872179	5.352384

So, a set of solutions to the homogeneous equations is

$$I_i = \sum_{j=1}^n \left(\frac{L'_j e^{-k_j \tau}}{1 + \mu_i k_j} \right) + \sum_{j=1}^n \left(\frac{L'_{-j} e^{k_j \tau}}{1 - \mu_i k_j} \right) \quad (7-60)$$

Now, we need a particular solution to equation (7-57). Assume one of the form

$$I_i = \frac{\pi}{4} \tilde{\omega} F h_i e^{-\tau/\mu_0} \quad (7-61)$$

where the h_i are constants. Substitute into equation (7-57) and we find that the h_i must satisfy

$$h_i \left(1 + \frac{\mu_i}{\mu_0} \right) = \frac{1}{2} \tilde{\omega} \sum_{j=-n}^n a_j h_j + 1 \quad (7-62)$$

and hence the h_i must have the form

$$h_i = \frac{\gamma}{1 + \frac{\mu_i}{\mu_0}} \quad (7-63)$$

where γ is an unknown constant. Put this back into equation (7-62)

$$\frac{1}{\gamma} = 1 - \tilde{\omega} \sum_{j=1}^n \left[\frac{a_j}{1 - (\mu_j^2/\mu_0^2)} \right] \quad (7-64)$$

Put equation (7-63) into equation (7-61) and combine with equation (7-60), and we get the complete solution to the system of equations (7-57)

$$I_i = \sum_{\alpha=1}^n \frac{L'_\alpha e^{-k_\alpha \tau}}{1 + \mu_i k_\alpha} + \sum_{\alpha=1}^n \frac{L'_{-\alpha} e^{k_\alpha \tau}}{1 - \mu_i k_\alpha} + \frac{\pi}{4} \tilde{\omega} F \frac{\gamma e^{-\tau/\mu_0}}{1 + (\mu_i/\mu_0)} \quad (7-65)$$

As before, in order to bound the radiance as $\tau \rightarrow \infty$, we must require that all the $L'_{-\alpha} = 0$, which leaves

$$I_i = \frac{\pi}{4} \tilde{\omega} F \left[\sum_{\alpha=1}^n \frac{L_\alpha e^{-k_\alpha \tau}}{1 + \mu_i k_\alpha} + \frac{\gamma e^{-\tau/\mu_0}}{1 + (\mu_i/\mu_0)} \right] \quad (7-66)$$

We apply the same boundary conditions at the top of the atmosphere—the incoming *diffuse* radiation at $\tau = 0$ is zero along the rays $-\mu_i$, and we get the system of equations for the n remaining constants L_α .

$$\sum_{\alpha=1}^n \frac{L_\alpha}{1 - \mu_i k_\alpha} + \frac{\gamma}{1 - (\mu_i/\mu_0)} = 0 \quad (7-67)$$

As a matter of comparison, note the difference between equation (7-67) and equation (7-19) for the conservative scattering case. In equation (7-67) the α -summation goes from 1 to n rather than from 1 to $(n - 1)$, and there is no Q constant. As pointed out above, these differences result from the fact that $K = 0$ is not a root. All the solutions we need are contained in equation (7-67).

With γ defined by equation (7-64), equation (7-67) again provides us with n equations in the n unknowns L_α . We can solve this system just as before to get the complete solution for the total radiation field. However, if we only want the law of darkening for the emerging field at the top of the atmosphere, this can again be expressed in terms of the H -function, and we need not evaluate the L_α . However, to carry along the numerical example, we will evaluate equation (7-67) for the $n = 4$ case we have been using. We will put arbitrarily $\tilde{\omega} = 0.8$ and get

$$\begin{aligned} \gamma &= 0.947722 \\ L_1 &= 0.516131 \\ L_2 &= 0.046078 \\ L_3 &= 0.246943 \\ L_4 &= -0.402956 \end{aligned}$$

This source function for this problem in the Gaussian approximation is, from equations (7-57),

$$J(\tau) = \frac{1}{2} \tilde{\omega} \sum_{j=-n}^n a_j I_j + \frac{\pi}{4} \tilde{\omega} F e^{-\tau/\mu_0}$$

If we substitute equation (7-65) into the above and reduce,

$$J(\tau) = \frac{\pi}{4} \tilde{\omega} F \left(\sum_{\alpha=1}^n L_\alpha e^{-k_\alpha \tau} + \gamma e^{-\tau/\mu_0} \right)$$

If we substitute this into equations (3-5) and (3-6) as before, with zero boundary conditions on the incoming diffuse radiation, we get for the complete solution to the radiation field at any τ, μ

$$I(\tau, \mu) = \frac{\pi}{4} \tilde{\omega} F \left(\sum_{\alpha=1}^n \frac{L_{\alpha} e^{-k_{\alpha} \tau}}{1 + k_{\alpha} \mu} + \frac{\gamma \mu_0 e^{-\tau/\mu_0}}{\mu_0 + \mu} \right) \quad (7-68)$$

$$I(\tau, -\mu) = \frac{\pi}{4} \tilde{\omega} F \left[\sum_{\alpha=1}^n \frac{L_{\alpha}}{1 - k_{\alpha} \mu} (e^{-k_{\alpha} \tau} - e^{-\tau/\mu_0}) + \frac{\gamma}{1 - \mu/\mu_0} (e^{-\tau/\mu_0} - e^{-\tau/\mu}) \right] \quad (7-69)$$

The law of darkening follows from equation (7-68) with $\tau = 0$

$$I(0, \mu) = \frac{\pi}{4} \tilde{\omega} F \left(\sum_{\alpha=1}^n \frac{L_{\alpha}}{1 + k_{\alpha} \mu} + \frac{\gamma \mu_0}{\mu_0 + \mu} \right) \quad (7-70)$$

We would like to write equation (7-70) in terms of the H -function as we did before. Again guided by the form of the characteristic equation, putting $z = 1/k$ we write for equation (7-59)

$$1 = \tilde{\omega} \sum_{j=1}^n \left[\frac{a_j}{1 - (\mu_j^2/z^2)} \right] = \tilde{\omega} z^2 \sum_{j=1}^n \frac{a_j}{z^2 - \mu_j^2} \quad (7-71)$$

and define the continuous function

$$T(z) = 1 - \tilde{\omega} z^2 \sum_{j=1}^n \frac{a_j}{z^2 - \mu_j^2} \quad (7-72)$$

Obviously, this must vanish for $z = 1/k$, since k is a root of the characteristic equation.

Now, $T(z)$ is a polynomial of degree zero. Thus,

$$T(z) \prod_{j=1}^n (z^2 - \mu_j^2)$$

is a polynomial of degree n in z with roots $\pm 1/k_{\alpha}$, $\alpha = 1, 2, \dots, n$. The polynomial

$$\prod_{j=1}^n (1 - k_{\alpha}^2 z^2)$$

is also of degree n in z with roots $\pm 1/k_\alpha$. Thus, as before, these two polynomials can differ by at most a multiplicative constant

$$T(z) \prod_{j=1}^n (z^2 - \mu_j^2) = K \prod_{j=1}^n (1 - k_\alpha^2 z^2) \quad (7-73)$$

From equation (7-72) we see that $T(0) = 1$, and hence if we set $z = 0$ in equation (7-73)

$$K = (-1)^n \mu_1^2 \mu_2^2 \cdots \mu_n^2$$

and, thus, from equation (7-73) we can write $T(z)$ as

$$\begin{aligned} T(z) &= (-1)^n \mu_1^2 \mu_2^2 \cdots \mu_n^2 \frac{\prod_{\alpha=1}^n (1 - k_\alpha z)^2}{\prod_{\alpha=1}^n (z^2 - \mu_\alpha^2)} \\ &= (-1)^n (\mu_1 \mu_2 \cdots \mu_n)^2 \frac{\prod_{\alpha=1}^n (1 - k_\alpha z) \prod_{\alpha=1}^n (1 + k_\alpha z)}{(-1)^n \prod_{\alpha=1}^n (\mu_\alpha - z) \prod_{\alpha=1}^n (\mu_\alpha + z)} \end{aligned} \quad (7-74)$$

But from the defining equation (7-49), this can be written

$$T(z) = \frac{1}{H(z)H(-z)} \quad (7-75)$$

If we let $z = \mu_0$ in equation (7-72)

$$T(\mu_0) = 1 - \tilde{\omega} \mu_0^2 \sum_{j=1}^n \frac{a_j}{\mu_0^2 - \mu_j^2} = 1 - \tilde{\omega} \sum_{j=1}^n \frac{a_j}{1 - (\mu_j^2/\mu_0^2)}$$

But this is exactly equal to the denominator of equation (7-64); thus, we get

$$\gamma = \frac{1}{T(\mu_0)} = H(\mu_0)H(-\mu_0) \quad (7-76)$$

giving us the unknown constant γ in terms of the H -functions.

Now, again repeating the earlier procedure, we can be guided by the form of the law of darkening, equation (7-70), and with equation (7-76) define the continuous function

$$S(\mu) = \sum_{\alpha=1}^n \frac{L_{\alpha}}{1 - k_{\alpha}\mu} + \frac{H(\mu_0)H(-\mu_0)}{1 - (\mu/\mu_0)} \quad (7-77)$$

in which again $S(\mu_i) = 0$, $i = 1, 2, \dots, n$. The law of darkening becomes

$$I(0, \mu) = \frac{\pi}{4} \tilde{\omega} F S(-\mu) \quad (7-78)$$

which we want to write in terms of the H -functions. The function

$$\left(1 - \frac{\mu}{\mu_0}\right) S(\mu) \prod_{\alpha=1}^n (1 - k_{\alpha}\mu) \quad (7-79)$$

is a polynomial of degree n in μ , which vanishes for $\mu = \mu_i$ because $S(\mu_i) = 0$. Thus we can write

$$\left(1 - \frac{\mu}{\mu_0}\right) S(\mu) \prod_{\alpha=1}^n (1 - k_{\alpha}\mu) = K' \prod_{\alpha=1}^n (\mu - \mu_{\alpha}) \quad (7-80)$$

or

$$S(\mu) = \frac{K' \prod_{\alpha=1}^n (\mu - \mu_{\alpha})}{1 - (\mu/\mu_0) \prod_{\alpha=1}^n (1 - k_{\alpha}\mu)} \quad (7-81)$$

Comparison of equation (7-81) with equation (7-48) shows that this is almost in the right form. If we redefine the constant K'

$$K' = K \frac{(-1)^n}{\mu_1 \mu_2 \cdots \mu_n}$$

then equation (7-81) can be manipulated to the form

$$S(\mu) = \frac{KH(-\mu)}{1 - (\mu/\mu_0)} \quad (7-82)$$

in which we now need to evaluate K . From equation (7-77)

$$\left(1 - \frac{\mu}{\mu_0}\right) S(\mu) = \left(1 - \frac{\mu}{\mu_0}\right) \sum_{\alpha=1}^n \frac{L_{\alpha}}{1 - k_{\alpha}\mu} + H(\mu_0)H(-\mu_0)$$

and from this we can see that as μ approaches μ_0

$$\lim_{\mu \rightarrow \mu_0} \left(1 - \frac{\mu}{\mu_0}\right) S(\mu) = H(\mu_0)H(-\mu_0)$$

while from equation (7-82)

$$\lim_{\mu \rightarrow \mu_0} \left(1 - \frac{\mu}{\mu_0}\right) S(\mu) = KH(-\mu_0)$$

and, thus, we find that $K = H(\mu_0)$, and equation (7-82) becomes

$$S(\mu) = \frac{H(\mu_0)H(-\mu)}{1 - (\mu/\mu_0)} \quad (7-83)$$

and the law of darkening, equation (7-78), becomes

$$I(0, \mu) = \frac{\pi}{4} \tilde{\omega} F \frac{\mu_0}{\mu_0 + \mu} H(\mu_0)H(\mu) \quad (7-84)$$

Recall Chandrasekhar's definition of the scattering function, equation (4-4)

$$I(0, \mu) = \frac{\pi F}{4\mu} S(\mu, \mu_0) \quad (7-85)$$

(The π comes in because of the way we have defined the incoming solar flux—Chandrasekhar defines it to be πF , while we have defined it as just F .)

If we compare equation (7-85) with equation (7-84), we find

$$\frac{\pi}{4} \tilde{\omega} F \frac{\mu_0}{\mu_0 + \mu} H(\mu_0)H(\mu) = \frac{\pi F}{4\mu} S(\mu, \mu_0)$$

or

$$\left(\frac{1}{\mu} + \frac{1}{\mu_0}\right) S(\mu, \mu_0) = \tilde{\omega} H(\mu_0)H(\mu) \quad (7-86)$$

which gives the scattering function in terms of the tabulated H -functions.

Use of equation (4-10) allows the reflection function $R(\mu, \mu_0)$ also to be written in terms of the H -function

$$\left(\frac{1}{\mu} + \frac{1}{\mu_0}\right) R(\mu, \mu_0) = \frac{\tilde{\omega}}{4\mu\mu_0} H(\mu_0)H(\mu) \quad (7-87)$$

We note that interchanging μ and μ_0 in equations (7-86) and (7-87) gives

$$S(\mu, \mu_0) = S(\mu_0, \mu)$$

$$R(\mu, \mu_0) = R(\mu_0, \mu)$$

which are examples of the *law of reciprocity*, a concept which occurs frequently and is much used in theoretical analyses.

Applying our numerical example to equation (7-70), with $\mu_0 = 0.4$, $\tilde{\omega} = 0.8$, and $n = 4$, we get the following comparison in table 7-6 with Chandrasekhar's exact results for the reflection function. Again we note that the $n = 4$ approximation is reasonably good, the maximum error being about 1 percent at $\mu = 0.5$.

TABLE 7-6. VALUES FROM EQUATION (7-70)

μ	$\left(\frac{I(0,\tau)}{\pi F}\right)_{n=4}$	$\left(\frac{I(0,\tau)}{\pi F}\right)_{\text{exact}}$
0.0	0.270783	0.272217
.1	.243725	.248014
.2	.219711	.222972
.3	.199753	.202310
.4	.183164	.185255
.5	.169225	.170984
.6	.157331	.158864
.7	.147081	.148436
.8	.138144	.139359
.9	.130277	.131380
1.0	.123693	.124303

Similarity Relations

We can note from our earlier developments that the radiation field is essentially characterized by three basic quantities—the phase function, the single-scattering albedo, and the optical thickness. A change in any of these quantities produces a change in the radiation field. The question thus arises: Can we change these parameters simultaneously in such a way that the radiation field remains at least approximately fixed? In particular, can we relate a given set of parameters $P(\mu, \mu')$, $\tilde{\omega}$, and τ to an equivalent set of isotropic parameters?

The answer is obviously yes, or we would not have raised the question here, and this section would not have been written. We have already

seen one example of such transformations in the discussion of the delta-Eddington method of chapter 6, in that equations (6-27) and (6-28) give a transformation which relates the delta-Eddington solution to the classical Eddington solution.

As pointed out by Sobolev (1975), the approximate similarity of the radiation field in an atmosphere with anisotropic scattering to the corresponding field in an atmosphere with isotropic scattering will take place only after a large number of scatterings; i.e., large optical thickness and $\tilde{\omega} \approx 1$. Also, similarity can only be discussed in connection with azimuthally averaged fields, since the isotropic radiance is azimuthally independent.

The diffuse radiation field in a plane-parallel atmosphere follows the now-familiar equation (2-29)

$$\mu \frac{dI}{d\tau} = I - \frac{\tilde{\omega}}{4\pi} \int I(\tau) P(\cos \theta) d\Omega \quad (7-88)$$

Suppose now we assume that the fraction r of the radiance is scattered isotropically (i.e., $P(\cos \theta) = 1$), and the remainder $(1 - r)$ is approximated by a Dirac delta function, so that we can write for the phase function

$$P(\cos \theta) = r + (1 - r)\delta \quad (7-89)$$

If we put equation (7-89) into equation (7-88)

$$\begin{aligned} \mu \frac{dI}{d\tau} &= I - \frac{\tilde{\omega}}{4\pi} \int I(\tau) [r + (1 - r)\delta] d\Omega \\ &= I - \frac{\tilde{\omega}}{4\pi} r \int I(\tau) d\Omega - \frac{\tilde{\omega}}{4\pi} (1 - r) 4\pi I \\ &= I [I - \tilde{\omega}(1 - r)] - \frac{\tilde{\omega}}{4\pi} r \int I(\tau) d\Omega \end{aligned} \quad (7-90)$$

If we divide through by $[I - \tilde{\omega}(1 - r)]$

$$\mu \frac{dI}{[I - \tilde{\omega}(1 - r)] d\tau} = I - \frac{\tilde{\omega}}{4\pi} \frac{r}{1 - \tilde{\omega}(1 - r)} \int I(\tau) d\Omega \quad (7-91)$$

and thus, by defining

$$\tau_I = [1 - \tilde{\omega}(1 - r)]\tau \quad (7-92)$$

and

$$\tilde{\omega}_I = \frac{\tilde{\omega}r}{1 - \tilde{\omega}(1 - r)} \quad (7-93)$$

we can write equation (7-91) in the form

$$\mu \frac{dI}{d\tau_I} = I - \frac{\tilde{\omega}_I}{4\pi} \int I(\tau) d\Omega \quad (7-94)$$

Equation (7-94) is therefore identical in form to equation (7-88) with $P(\cos\theta) = 1$, which thus describes isotropic scattering. In this way, equations (7-92) and (7-93) can be considered to be *similarity* relations which transform the anisotropic problem of equation (7-88) to the equivalent isotropic problem of equation (7-94), under the assumption in equation (7-89).

We now have to determine the quantity r in equation (7-89). The more forward scattering we have, the smaller the value of r . We have seen earlier that, in the Henyey-Greenstein phase function, the factor g controls the size of the forward-scattering peak; the larger the amount of forward scatter the more nearly g approached unity. Thus, if we *choose*

$$r = 1 - g \quad (7-95)$$

then we get

$$\tau_1 = (1 - \tilde{\omega}g)\tau \quad (7-96)$$

and

$$\tilde{\omega}_1 = \frac{\tilde{\omega}(1 - g)}{1 - \tilde{\omega}g} \quad (7-97)$$

as our set of similarity relations.

The discussions in Sobolev (1975) and Irvine (1975) indicate that equations (7-96) and (7-97) produce solutions that agree well with more nearly exact solutions in most cases, the agreement generally being better for integrated quantities, such as total albedo or the atmospheric flux, rather than quantities such as radiance. Again, this is because the integration, after multiple scattering, tends to smooth out the effects of the phase function.

The similarity solutions for one of the cases given earlier for the two-stream and Eddington methods are presented below and in figure 7-3. The $H(\mu_0)$ were interpolated in the tables of H -functions at the end of chapter 8. The similarity relations give the correspondences in table 7-7. The correspondences in table 7-7 in turn give the values for the reflection function shown in table 7-8.

TABLE 7-7. CORRESPONDENCES

$\tilde{\omega}$	$\bar{\omega}_2$
0.99	0.9802
.95	.9048
.90	.8182

TABLE 7-8. $r(\mu_0)$, SIMILARITY SOLUTIONS

μ_0	$\tilde{\omega} = 0.99$	$\tilde{\omega} = 0.95$	$\tilde{\omega} = 0.90$
0.0	0.8593	0.6915	0.5736
.1	.8285	.6377	.5121
.2	.8048	.6003	.4718
.3	.7835	.5688	.4392
.4	.7635	.5414	.4116
.5	.7447	.5169	.3877
.6	.7268	.4947	.3667
.7	.7098	.4746	.3479
.8	.6971	.4561	.3311
.9	.6772	.4391	.3159
1.0	.6616	.4234	.3020

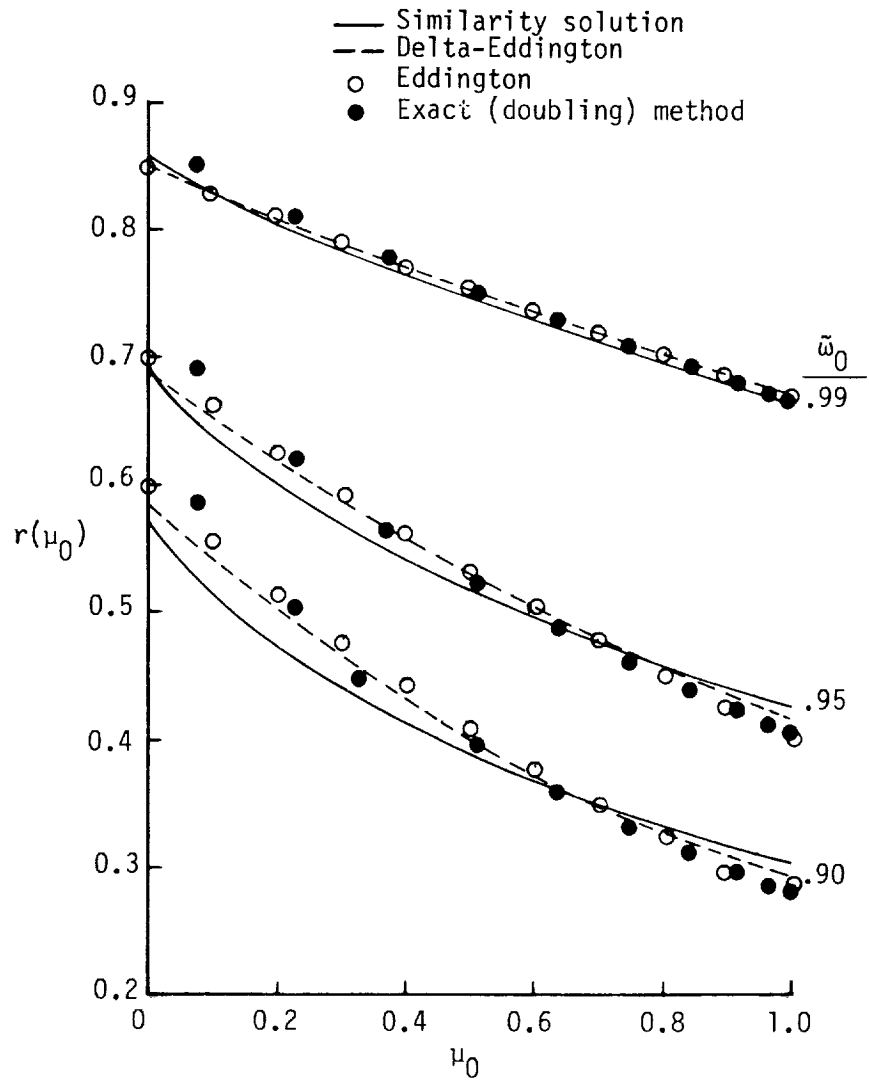

Figure 7-3. The similarity relations equations (7-92) and (7-93) used for the same case as figure 6-1.

Chapter 8

The Principle of Invariance

The principle of invariance is a very elegant concept that was first put forth by Ambartsumyan (1958) and later perfected by Chandrasekhar and others. The principle is deceptively simple and will be applied here to the case of a semi-infinite, homogeneous atmosphere. It allows us to derive a single integral equation for a function which can be identified with the H -function. This linear equation permits the exact computation of the H -function. (The numerical solution is an iterative one. Thus, it is exact only in the limit, but practically converges to 6 to 8 decimals in a few iterations for small values of the single-scattering albedo. The convergence is slower as the single-scattering albedo approaches unity.)

The principle of invariance for an infinitely thick atmosphere can be stated as follows: we are given the infinitely thick atmosphere with certain reflection and absorption properties. If we add an additional layer of the same optical properties to the top of the atmosphere, we do not change the overall reflective and absorptance characteristics of the atmosphere. By adding a *thin* layer, we can compute the differential change in reflection and absorption and set these changes to zero. The result is a linear integral equation for a function which we can relate to the H -function derived in the last chapter.

We will follow essentially the development of Liou, and use his definition of the reflection and transmission functions, and then relate the final equation to the form developed by Chandrasekhar.

We assume that the added layer is so thin that at most a single scatter can occur in it. Then, for a given photon which is reflected out of the top of the atmosphere, only one of the five histories sketched in figure 8-1 can occur:

1. The photon can penetrate the thin layer and be reflected from the infinitely thick layer (ITL).
2. The photon can be singly scattered upward from the thin layer before it reaches the ITL.

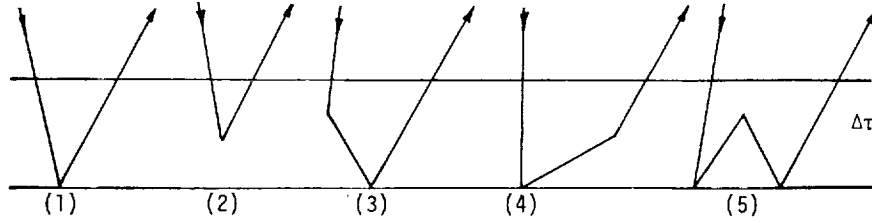

Figure 8-1. Sketch showing the five single-scatter scenarios between the added thin layer and the infinitely thick layer (ITL).

3. The photon can be singly scattered downward by the thin layer, then reflect upward from the ITL.
4. The photon can penetrate the thin layer, reflect from the ITL, and then be singly scattered upward by the thin layer.
5. The photon can penetrate the thin layer, reflect upward from the ITL, and then be singly scattered downward by the thin layer to be once more reflected up and out by the ITL.

We assume that $\Delta\tau$, the thickness of the thin layer, is $\ll 1$, and hence only terms linear in $\Delta\tau$ will be retained. The single-scattering albedo determines the fraction of the incoming photons which are scattered. In the thin layer, it is assumed that there is no absorption along a path which involves a single scatter, but that there is absorption along a path which penetrates the thin layer and along which there is no scatter. In other words, we assume that a given photon may be either absorbed or scattered, but not both.

For azimuthal symmetry, Liou's definition for the reflection function follows from equation (4-6)

$$I(0, \mu) = 2 \int_0^1 R(\mu, \mu') I(0, -\mu') \mu' d\mu' \quad (8-1)$$

The reflection coefficient for an infinitely thin layer can be obtained from the single-scattering solution given by equation (5-33b), which for $\tau^* = \Delta\tau \ll 1$ reduces to

$$I(0, \mu) = \frac{\tilde{\omega} \Delta\tau}{4\mu\mu_0} P(\mu, -\mu_0) \mu_0 F_0 \quad (8-2)$$

and hence, the reflection coefficient becomes

$$R(\mu, \mu_0) = \frac{\tilde{\omega} \Delta\tau}{4\mu\mu_0} P(\mu, -\mu_0) \quad (8-3)$$

For thin layers, the transmission function reduces to

$$e^{-\Delta\tau/\mu} \approx 1 - \frac{\Delta\tau}{\mu}$$

The simplest way the writer has found to derive the differential changes in R due to the addition of the thin layer is to start with the emergent beam and work backwards to the source. This will be done in the five parts of figure 8-1 for each of the five scenarios sketched above.

In figure 8-1(a), reflection from the ITL,

$$\begin{aligned} I(-\Delta\tau, \mu) &= (1 - \Delta\tau/\mu)I(0, \mu) \\ I(0, \mu) &= I(0, -\mu_0)R(\mu, \mu_0) \\ I(0, -\mu_0) &= (1 - \Delta\tau/\mu_0)\mu_0 F_0 \end{aligned}$$

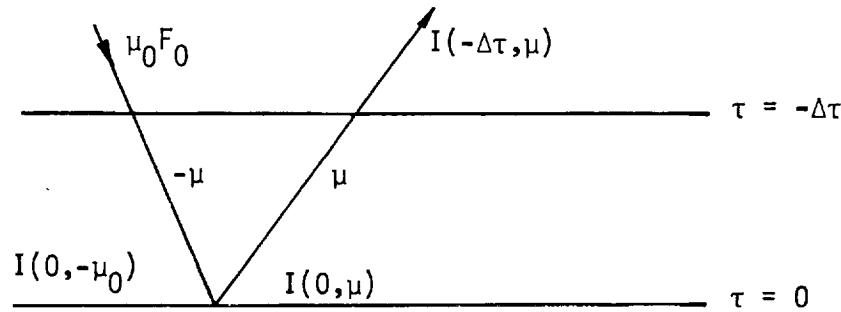

Figure 8-1(a). Sketch of the first event, reflection from the ITL.

Put all these together

$$I(-\Delta\tau, \mu) = (1 - \Delta\tau/\mu)R(\mu, \mu_0)(1 - \Delta\tau/\mu_0)\mu_0 F_0$$

Expand and retain only terms to first order in $\Delta\tau$

$$I(-\Delta\tau, \mu)/\mu_0 F_0 = R(\mu, \mu_0) - R(\mu, \mu_0)(\Delta\tau/\mu + \Delta\tau/\mu_0)$$

But this is the *new* reflection coefficient, and hence the *change* in the reflection coefficient due to this first event is

$$\Delta R_1(\mu, \mu_0) = -R(\mu, \mu_0) \Delta\tau (1/\mu_0 + 1/\mu) \quad (8-4)$$

In figure 8-1(b), single upward scatter from the *thin* layer,

$$I(-\Delta\tau, \mu) = R(\mu, \mu_0)\mu_0 F_0$$

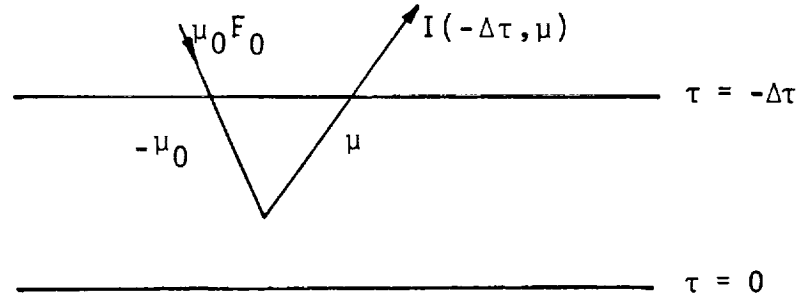

Figure 8-1(b). Sketch of the second event, single upward scatter from the *thin* layer.

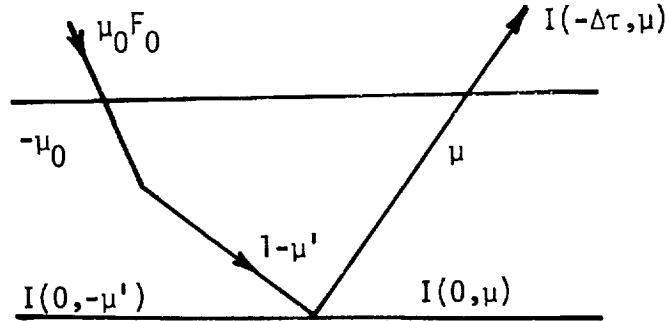

Figure 8-1(c). Sketch of the third event, single scatter from the thin layer followed by a reflection from the ITL.

and from equation (8-3)

$$I(-\Delta\tau, \mu) = \frac{\tilde{\omega} \Delta\tau}{4\mu\mu_0} P(\mu, -\mu_0) \mu_0 F_0$$

and hence,

$$\Delta R_2(\mu, \mu_0) = \frac{\tilde{\omega} \Delta\tau}{4\mu\mu_0} P(\mu, -\mu_0) \quad (8-5)$$

In figure 8-1(c), single scatter from the thin layer followed by a reflection from the ITL,

$$\begin{aligned} I(-\Delta\tau, \mu) &= (1 - \Delta\tau/\mu) I(0, \mu) \\ I(0, \mu) &= R(\mu, \mu') I(0, -\mu') \\ I(0, -\mu') &= \left(\frac{\tilde{\omega} \Delta\tau}{4\mu'\mu_0} \right) P(-\mu', -\mu_0) \mu_0 F_0 \end{aligned}$$

But since all possible μ' must be included, we must use equation (8-1)

$$\begin{aligned} I(-\Delta\tau, \mu) &= 2 \int_0^1 \mu' d\mu' \left(1 - \frac{\Delta\tau}{\mu}\right) R(\mu, \mu') \mu_0 F_0 \frac{\tilde{\omega} \Delta\tau}{4\mu\mu'} P(-\mu', -\mu_0) \\ &= \mu_0 F_0 \frac{\tilde{\omega} \Delta\tau}{2\mu_0} \left(1 - \frac{\Delta\tau}{\mu}\right) \int_0^1 R(\mu, \mu') P(-\mu', -\mu_0) d\mu' \end{aligned}$$

and so to order $\Delta\tau$

$$\Delta R_3(\mu, \mu_0) = \frac{\tilde{\omega} \Delta\tau}{2\mu_0} \int_0^1 R(\mu, \mu') P(-\mu', -\mu_0) d\mu' \quad (8-6)$$

In figure 8-1(d), reflection from the ITL followed by an upward scatter from the thin layer,

$$\begin{aligned} I(-\Delta\tau, \mu) &= \left(\frac{\tilde{\omega} \Delta\tau}{4\mu\mu'}\right) P(\mu, \mu') I(0, \mu') \\ I(0, \mu') &= R(\mu', -\mu_0) I(0, -\mu_0) \\ I(0, -\mu_0) &= (1 - \Delta\tau/\mu_0) \mu_0 F_0 \end{aligned}$$

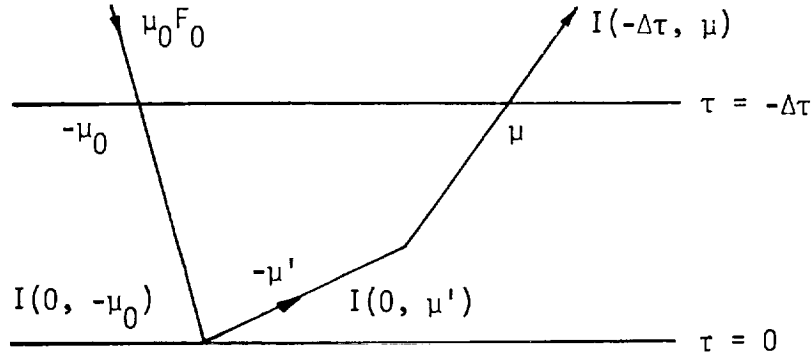

Figure 8-1(d). Sketch of the fourth event, reflection from the ITL followed by an upward scatter from the thin layer.

Again, using equation (8-1) we get

$$I(-\Delta\tau, \mu) = \frac{\tilde{\omega} \Delta\tau}{2\mu} \mu_0 F_0 \left(1 - \frac{\Delta\tau}{\mu_0}\right) \int_0^1 R(\mu', -\mu_0) P(\mu, \mu') d\mu'$$

or

$$\Delta R_4(\mu, \mu_0) = \frac{\tilde{\omega} \Delta\tau}{2\mu} \int_0^1 R(\mu', -\mu_0) P(\mu, \mu') d\mu' \quad (8-7)$$

In figure 8-1(e), reflection from the ITL, followed by a downward scatter from the thin layer, and a final reflection from the ITL,

$$\begin{aligned} I(-\Delta\tau, \mu) &= (1 - \Delta\tau/\mu)I(0, \mu) \\ I(0, \mu) &= R(\mu, \mu')I(0, -\mu') \end{aligned}$$

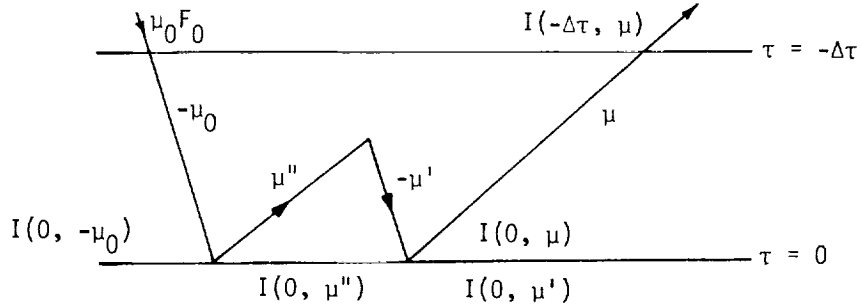

Figure 8-1(e). Sketch of the fifth event, reflection from the ITL, followed by a downward scatter from the thin layer, and a final reflection from the ITL.

and hence, integrating over all μ' ,

$$I(0, \mu) = 2 \int_0^1 \mu' R(\mu, \mu') I(0, -\mu') d\mu'$$

Now,

$$I(0, \mu') = \frac{\tilde{\omega} \Delta\tau}{4\mu' \mu''} P(-\mu', \mu'') I(0, \mu'')$$

and we can write $I(0, \mu)$ as

$$I(0, \mu) = \frac{\tilde{\omega} \Delta\tau}{2\mu''} I(0, \mu'') \int_0^1 R(\mu, \mu') P(-\mu', \mu'') d\mu'$$

and to order $\Delta\tau$

$$I(-\Delta\tau, \mu) = \frac{\tilde{\omega} \Delta\tau}{2\mu''} I(0, \mu'') \int_0^1 R(\mu, \mu') P(-\mu', \mu'') d\mu'$$

But now,

$$I(0, \mu'') = I(0, -\mu_0)R(\mu'', -\mu_0) = \left(1 - \frac{\Delta\tau}{\mu_0}\right) R(\mu'', -\mu_0)\mu_0 F_0$$

But this must be integrated once more, this time over all μ'' , and we get

$$I(-\Delta\tau, \mu) = 2(\mu_0 F_0) \int_0^1 \mu'' d\mu'' \frac{\tilde{\omega} \Delta\tau}{2\mu''} R(\mu'', -\mu_0) \int_0^1 R(\mu, \mu') P(-\mu', \mu'') d\mu'$$

or, regrouping the integrals

$$\Delta R_5(\mu, \mu_0) = \tilde{\omega} \Delta\tau \int_0^1 R(\mu, \mu') d\mu' \int_0^1 R(\mu'', -\mu_0) P(-\mu', \mu'') d\mu'' \quad (8-8)$$

Now, according to the principle of invariance

$$\Delta R_1 + \Delta R_2 + \Delta R_3 + \Delta R_4 + \Delta R_5 = 0 \quad (8-9)$$

and so, from equation (8-4) to equation (8-8) in equation (8-9), we divide out the $\Delta\tau$ and factor out $\tilde{\omega}/4\mu\mu_0$, and write

$$\begin{aligned} \left(\frac{1}{\mu_0} + \frac{1}{\mu}\right) R(\mu, \mu_0) = \frac{\tilde{\omega}}{4\mu\mu_0} & \left\{ P(-\mu, \mu_0) + 2\mu \int_0^1 P(-\mu', -\mu_0) R(\mu, \mu') d\mu' \right. \\ & + 2\mu_0 \int_0^1 P(\mu, \mu') R(\mu', \mu_0) d\mu' \\ & + \left[2\mu \int_0^1 R(\mu, \mu') d\mu' \right] \\ & \left. \times \left[2\mu_0 \int_0^1 P(-\mu', \mu'') R(\mu'', \mu_0) d\mu'' \right] \right\} \quad (8-10) \end{aligned}$$

which is the desired integral equation for $R(\mu, \mu_0)$. Note that this equation is nonlinear. The only restrictions on equation (8-10) are that the atmosphere must be homogeneous, plane-parallel, and semi-infinite.

Now, let us consider the case of isotropic scattering. Then all of the phase functions in equation (8-10) are equal to unity, and

$$\begin{aligned} \left(\frac{1}{\mu_0} + \frac{1}{\mu}\right) R(\mu, \mu_0) = \frac{\tilde{\omega}}{4\mu\mu_0} & \left[1 + 2\mu \int_0^1 R(\mu, \mu') d\mu' + 2\mu_0 \int_0^1 R(\mu', \mu_0) d\mu' \right. \\ & \left. + 4\mu\mu_0 \int_0^1 R(\mu, \mu') d\mu' \int_0^1 R(\mu'', \mu_0) d\mu'' \right] \quad (8-11) \end{aligned}$$

If we interchange μ and μ_0 in equation (8-11), we get the same expression, indicating that $R(\mu, \mu_0)$ and $R(\mu_0, \mu)$ both satisfy equation (8-11). This does not prove, of course, that $R(\mu, \mu_0) = R(\mu_0, \mu)$. As it turns out, this is indeed equality, but since its validity can only be established by a rather lengthy analysis (Chandrasekhar), we will accept without proof

$$R(\mu, \mu_0) = R(\mu_0, \mu) \quad (8-12)$$

as another manifestation of the principle of reciprocity.

Equation (8-11) can be factored to give

$$\left(\frac{1}{\mu_0} + \frac{1}{\mu}\right) R(\mu, \mu_0) = \frac{\tilde{\omega}}{4\mu\mu_0} \left[1 + 2\mu \int_0^1 R(\mu, \mu') d\mu'\right] \left[1 + 2\mu_0 \int_0^1 R(\mu', \mu_0) d\mu'\right] \quad (8-13)$$

Guided by the form of equation (7-87) we can define

$$H(\mu) = 1 + 2\mu \int_0^1 R(\mu, \mu') d\mu' \quad (8-14)$$

and write equation (8-13) as

$$\left(\frac{1}{\mu_0} + \frac{1}{\mu}\right) R(\mu, \mu_0) = \frac{\tilde{\omega}}{4\mu\mu_0} H(\mu)H(\mu_0) \quad (8-15)$$

and we see that equation (8-14) is another definition of the H -function. Equation (8-14) is exact in that it does not involve any orders of approximation.

If we write equation (8-15) as

$$R(\mu, \mu_0) = \frac{\tilde{\omega}}{4} \frac{H(\mu)H(\mu_0)}{\mu + \mu_0} \quad (8-16)$$

and substitute equation (8-16) back into equation (8-14), we get

$$H(\mu) = 1 + \frac{\tilde{\omega}}{2} \mu H(\mu) \int_0^1 \frac{H(\mu') d\mu'}{\mu + \mu'} \quad (8-17)$$

which is the integral equation for H promised earlier. Equation (8-17) can be solved iteratively to determine $H(\mu)$ to any degree of accuracy.

Chandrasekhar presents a much more sophisticated derivation of equation (8-13) and the succeeding relations, resulting in an equation very similar to equation (8-11) for his scatter function; his equation

can, of course, be obtained from our equation (8-11) by using the correspondence equation (4-10). Once the physics of our derivation of equation (8-11) is fully understood, it can be of great benefit to review Chandrasekhar's analysis, from the point of view of gaining facility in manipulating the fundamental definitions and using the integral form of the RTE to develop our results.

The mean value of $H(\mu)$, H_0 , is a useful starting point for the iterative solution of equation (8-17). Define

$$H_0 = \int_0^1 H(\mu) d\mu \quad (8-18)$$

Multiply equation (8-17) by $d\mu$ and integrate

$$\int_0^1 H(\mu) d\mu = 1 + \frac{\tilde{\omega}}{2} \int_0^1 \int_0^1 \frac{H(\mu)H(\mu')\mu'}{\mu + \mu'} d\mu' d\mu$$

Interchange μ and μ' in the above and add the two results together

$$\begin{aligned} 2 \int_0^1 H(\mu) d\mu &= 2 + \frac{\tilde{\omega}}{2} \left[\int_0^1 \int_0^1 \frac{H(\mu)H(\mu')\mu'}{\mu + \mu'} d\mu' d\mu \right. \\ &\quad \left. + \int_0^1 \int_0^1 \frac{H(\mu')H(\mu)\mu}{\mu' + \mu} d\mu d\mu' \right] \\ &= 2 + \frac{\tilde{\omega}}{2} \left[\int_0^1 \int_0^1 H(\mu)H(\mu') d\mu d\mu' \right] \end{aligned}$$

or

$$H_0 = 1 + \frac{\tilde{\omega}}{4} H_0^2$$

from which

$$H_0 = \frac{2}{\tilde{\omega}} \left(1 - \sqrt{1 - \tilde{\omega}} \right) \quad (8-19)$$

We now write equation (4-17) for the planetary albedo for the model atmosphere in terms of the H -functions

$$r(\mu_0) = 2 \int_0^1 R(\mu, \mu_0)\mu d\mu$$

and using equation (8-16)

$$\begin{aligned} r(\mu_0) &= \frac{\tilde{\omega}}{2} H(\mu_0) \int_0^1 H(\mu) \left(1 - \frac{\mu_0}{\mu_0 + \mu}\right) d\mu \\ &= \frac{\tilde{\omega}}{2} H(\mu_0) \left[\int_0^1 H(\mu) d\mu - \mu_0 \int_0^1 \frac{H(\mu)}{\mu_0 + \mu} d\mu \right] \end{aligned}$$

By use of equation (8-17) the integral can be eliminated to give, along with equation (8-19)

$$r(\mu_0) = 1 - H(\mu_0) \sqrt{1 - \tilde{\omega}} \quad (8-20)$$

Equation (8-20) is plotted in figure 8-2 for various values of $\tilde{\omega}$. The spherical albedo follows from equation (4-24)

$$\bar{r} = 1 - 2\sqrt{1 - \tilde{\omega}} \int_0^1 \mu_0 H(\mu_0) d\mu_0 \quad (8-21)$$

The first-moment integral in equation (8-21) was evaluated numerically from the H -function tables, and \bar{r} vs. $\tilde{\omega}$ is plotted in figure 8-3.

We can get an approximate analytic form for the H -function, and thus the reflection coefficient from the two-stream solution. For the two-stream case, $n = 1$, $\mu = 1/\sqrt{3}$, $a_1 = 1$, and the eigenvalues follow immediately from equation (7-59)

$$k = \sqrt{3(1 - \tilde{\omega})}$$

From the definition of the H -function, equation (7-49)

$$H(\mu) = \frac{1 + \mu\sqrt{3}}{1 + \mu\sqrt{3(1 - \tilde{\omega})}} \quad (8-22)$$

and thus the reflection function becomes

$$R(\mu, \mu_0) = \frac{\tilde{\omega}}{4(\mu + \mu_0)} \frac{(1 + \mu\sqrt{3})(1 + \mu_0\sqrt{3})}{\left[1 + \mu\sqrt{3(1 - \tilde{\omega})}\right] \left[1 + \mu_0\sqrt{3(1 - \tilde{\omega})}\right]} \quad (8-23)$$

If we evaluate $H(\mu)$ for the $n = 4$ case used as our example, we get for $\mu = 0.5$, $\tilde{\omega} = 0.8$, the data in table 8-1.

It can be seen that going from a two-stream to an eight-stream model significantly improves the accuracy of evaluating the H -functions, and hence also the reflection functions.

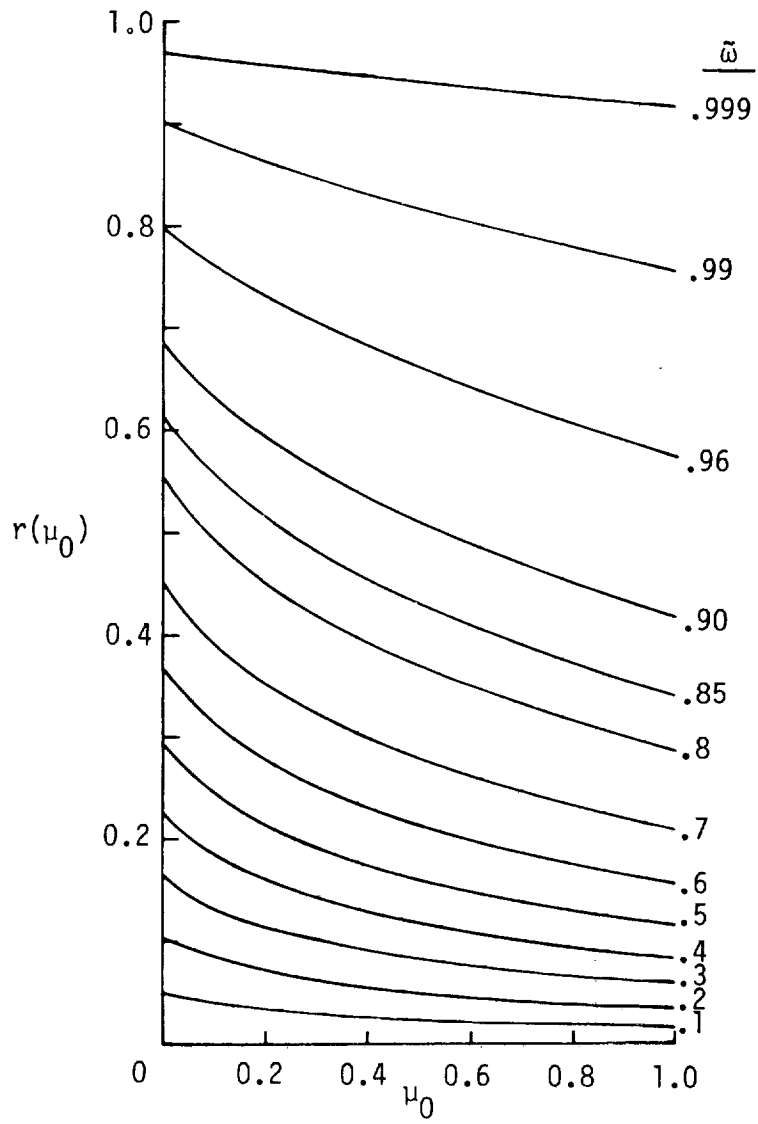

Figure 8-2. Reflection coefficient for an isotropic semi-infinite atmosphere, computed from the Chandrasekhar H -functions.

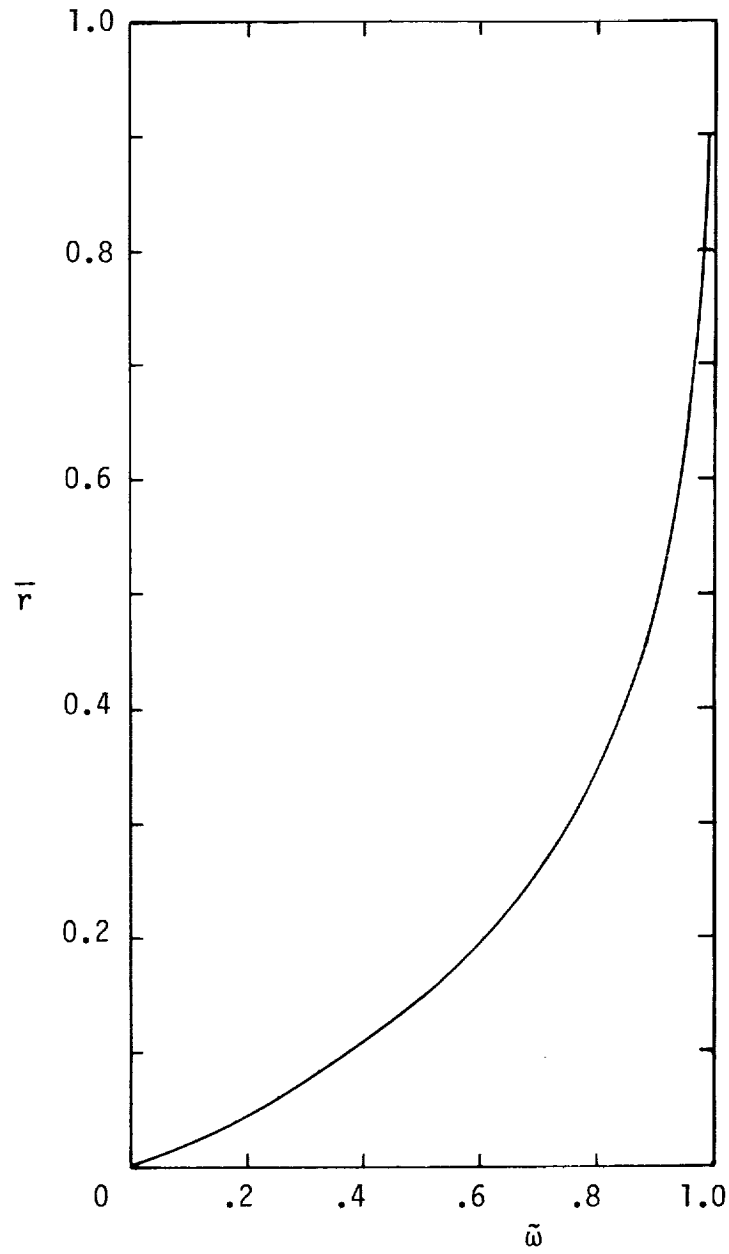

Figure 8-3. Spherical albedo for isotropic scattering. Exact from H -function.



TABLE 8-1. $R(\mu, \mu_0)$

μ	2-Stream	8-Stream	Exact
0.0	0.53803	0.56256	0.56528
0.1	.49378	.52749	.53645
0.2	.46589	.48915	.49607
0.3	.44759	.45399	.45950
0.4	.43529	.42289	.42745
0.5	.42689	.39559	.39943
0.6	.42112	.37152	.37488
0.7	.41717	.35022	.35318
0.8	.41450	.33124	.33391
0.9	.41276	.31423	.31666
1.0	.41169	.29891	.30114

First-Order Solution for the H -Function

The zeroth-order solution for $H(\mu)$ is given by equation (8-19). If we use this in the right-hand side of equation (8-17), as the first guess of $H(\mu)$, we get the first-order solution

$$\begin{aligned}
 H_1(\mu) &= 1 + \frac{\tilde{\omega}}{2} \mu H_0^2 \int_0^1 \frac{d\mu'}{\mu + \mu'} \\
 H_1(\mu) &= 1 + \frac{\tilde{\omega}}{2} \mu H_0^2 \ln \left(\frac{1 + \mu}{\mu} \right) \quad (8-24a)
 \end{aligned}$$

A somewhat better approximation can be obtained by first solving equation (8-17) for $H(\mu)$ to give

$$H(\mu) = \left[1 - \frac{\tilde{\omega}}{2} \mu \int_0^1 \frac{H(\mu') d\mu'}{\mu + \mu'} \right]^{-1}$$

and then solving this by substituting H_0 for $H(\mu)$ on the right-hand side. This gives

$$H_1(\mu) = \left[1 - \frac{\tilde{\omega}}{2} \mu H_0 \ln \left(\frac{1 + \mu}{\mu} \right) \right]^{-1} \quad (8-24b)$$

For $\tilde{\omega} = 0.5$, reflection coefficients computed from equation (8-20), using the first-order solutions for H from both equations (8-24a) and (8-24b),

are compared in figure 8-4 with the exact solution using the exact H -functions tabulated at the end of this chapter. Both approximations are adequate for large absorption ($\tilde{\omega} \ll 1$), but equation (8-24b) gives decidedly better results for larger $\tilde{\omega}$ (nearly conservative scattering). Whether either approximation is adequate depends, of course, on the application.

Equation (8-24a) or equation (8-24b) could, in turn, be resubstituted into equation (8-17) and a second-order solution derived. The algebra, however, becomes quite messy, and it is probably advisable to evaluate the resulting integrals numerically if this order of approximation is required.

Table 8-2 compares results computed for equations (8-24a) and (8-24b) with the exact results.

TABLE 8-2. VALUES OF $H_1(\mu)$

μ	Equation (8-24a)	Equation (8-24b)	Exact
0.0	1.00000	1.00000	1.00000
0.1	1.07935	1.07554	1.07241
0.2	1.11315	1.11727	1.11349
0.3	1.13281	1.14790	1.14391
0.4	1.14615	1.17202	1.16800
0.5	1.15721	1.19174	1.18776
0.6	1.16848	1.20826	1.20436
0.7	1.18146	1.22237	1.21858
0.8	1.19706	1.23459	1.23091
0.9	1.21578	1.24528	1.24171
1.0	1.23785	1.25473	1.25128

The iteration procedure for computing $H(\mu)$ uses H_0 , equations (8-24), as the first guess and proceeds from equation (8-17). The solution converges fairly rapidly for small $\tilde{\omega}$, but more and more iterations are needed as $\tilde{\omega} \rightarrow 1$. Tables of the H -function for isotropic scattering are included at the end of this chapter (table 8-3).

If one uses equation (8-17) directly, the convergence proceeds somewhat as shown in figure 8-5.

Chandrasekhar, recognizing the slowness of the convergence of equation (8-17), gives an alternate integral equation form for $H(\mu)$

$$\frac{1}{H(\mu)} = \sqrt{1 - \tilde{\omega}} + \frac{\tilde{\omega}}{2} \int_0^1 \frac{\mu' H(\mu')}{\mu + \mu'} d\mu' \quad (8-25)$$

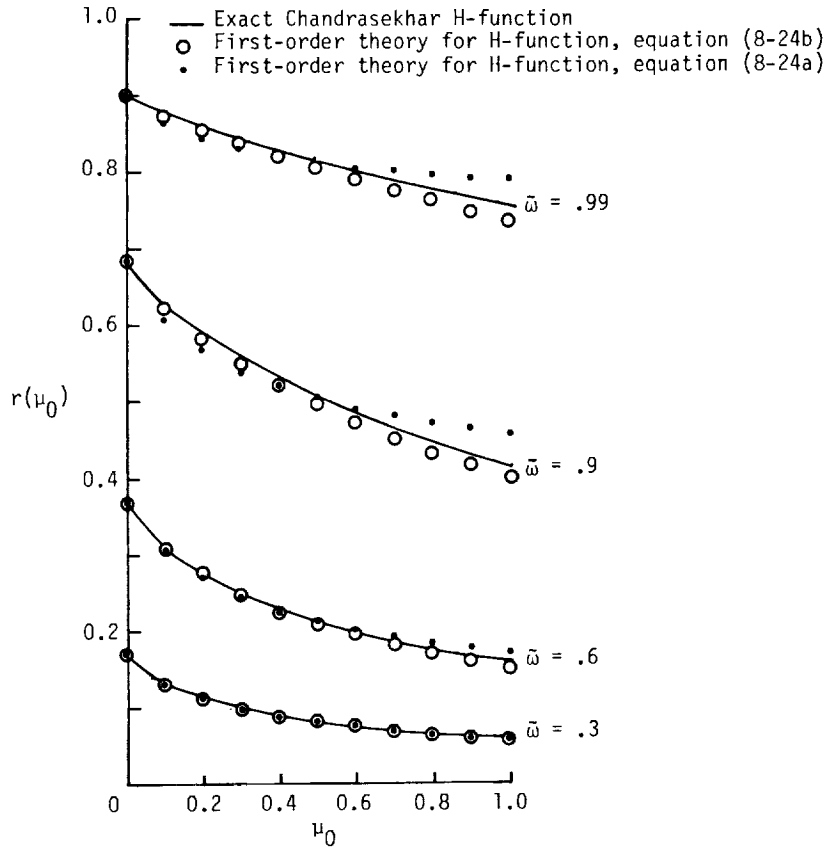

Figure 8-4. Selected single-scatter albedo solution from figure 8-2 showing the accuracy of two of the approximate solutions, equations (8-24a) and (8-24b).

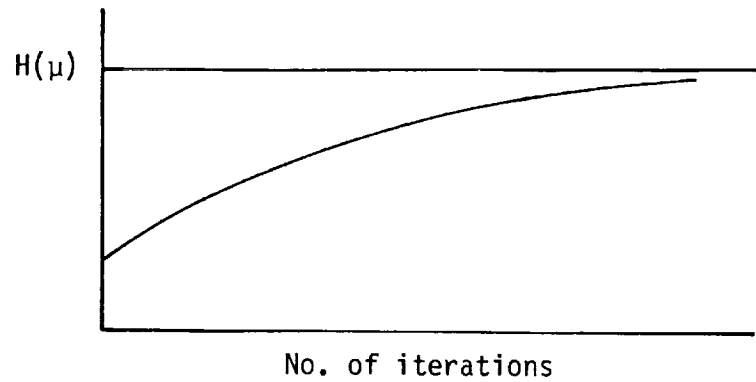

Figure 8-5. Sketch illustrating the iterative behavior of equation (8-17).

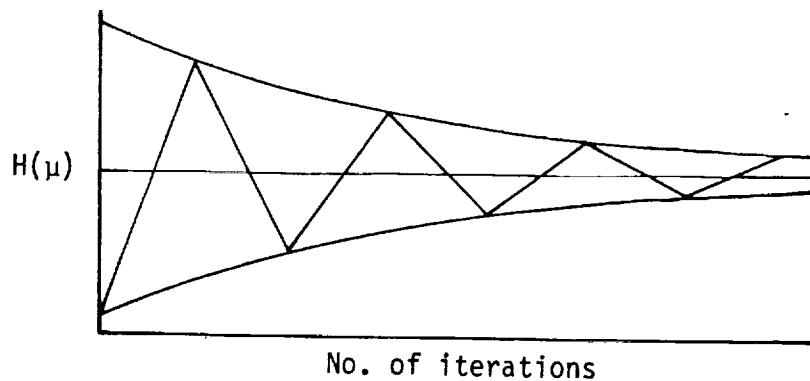

Figure 8-6. Sketch illustrating the iterative behavior of equation (8-25).

By a straight application of equation (8-25), however, no significant improvement in the rate of convergence is noticed, although Chandrasekhar claims that it is decidedly superior to equation (8-17). Its convergence proceeds as sketched in figure 8-6. Convergence could perhaps be speeded up somewhat if we take, for example, the mean of the zeroth and first iterations as the second guess, the mean of the second and third iterations as the fourth guess, etc. This was not tried by the writer. Chandrasekhar's iterative procedure is not discussed in his text, but perhaps this is the method he used to increase the rate of convergence. The problem is, of course, academic, as numerical solutions are available for all $\tilde{\omega}$, and the job is finished.

TABLE 8-3. *H*-FUNCTIONS FOR ISOTROPIC SCATTERING

μ	$\tilde{\omega} = 0.1$	$\tilde{\omega} = 0.2$	$\tilde{\omega} = 0.3$	$\tilde{\omega} = 0.4$	$\tilde{\omega} = 0.5$
0.00	1.000000	1.000000	1.000000	1.000000	1.000000
0.05	1.007841	1.016118	1.024902	1.034293	1.044428
0.10	1.012385	1.025632	1.039895	1.055387	1.072402
0.15	1.015844	1.032948	1.051553	1.071988	1.094720
0.20	1.018645	1.038919	1.061149	1.085784	1.113465
0.25	1.020993	1.043956	1.069300	1.097594	1.129654
0.30	1.023006	1.048296	1.076365	1.107899	1.143889
0.35	1.024760	1.052095	1.082581	1.117017	1.156568
0.40	1.026306	1.055459	1.088110	1.125169	1.167971
0.45	1.027685	1.058467	1.093072	1.132519	1.178306
0.50	1.028922	1.061177	1.097559	1.139192	1.187734
0.55	1.030042	1.063634	1.101641	1.145285	1.196381
0.60	1.031060	1.065875	1.105375	1.150876	1.204347
0.65	1.031991	1.067929	1.108805	1.156030	1.211717
0.70	1.032846	1.069820	1.111971	1.160799	1.218559
0.75	1.033635	1.071567	1.114903	1.165227	1.224932
0.80	1.034365	1.073187	1.117626	1.169352	1.230885
0.85	1.035043	1.074694	1.120165	1.173203	1.236459
0.90	1.035674	1.076099	1.122536	1.176810	1.241693
0.95	1.036264	1.077413	1.124758	1.180196	1.246617
1.00	1.036816	1.078645	1.126844	1.183380	1.251259
Mean	1.026334	1.055728	1.088933	1.127017	1.171573
1st mom.	0.515611	0.533155	0.553122	0.576214	0.603486

TABLE 8-3. Continued

μ	$\tilde{\omega} = 0.6$	$\tilde{\omega} = 0.7$	$\tilde{\omega} = 0.8$	$\tilde{\omega} = 0.85$	$\tilde{\omega} = 0.90$
0.00	1.000000	1.000000	1.000000	1.000000	1.000000
0.05	1.055513	1.067885	1.082180	1.090455	1.099980
0.10	1.091388	1.113078	1.138860	1.154176	1.172201
0.15	1.120454	1.150357	1.186654	1.208633	1.234933
0.20	1.145168	1.182519	1.228642	1.257015	1.291436
0.25	1.166734	1.210934	1.266321	1.300861	1.343268
0.30	1.185867	1.236418	1.300586	1.341086	1.391346
0.35	1.203043	1.259515	1.332031	1.378299	1.436276
0.40	1.218599	1.280617	1.361086	1.412937	1.478491
0.45	1.232788	1.300016	1.388077	1.445334	1.518322
0.50	1.245806	1.317943	1.413259	1.475753	1.556029
0.55	1.257807	1.334580	1.436839	1.504405	1.591821
0.60	1.268919	1.350077	1.458986	1.531467	1.625876
0.65	1.279244	1.364560	1.479845	1.557089	1.658340
0.70	1.288870	1.378134	1.499537	1.581397	1.689343
0.75	1.297870	1.390887	1.518166	1.604501	1.718996
0.80	1.306306	1.402899	1.535825	1.626499	1.747398
0.85	1.314234	1.414235	1.552593	1.647475	1.774634
0.90	1.321700	1.424955	1.568540	1.667505	1.800784
0.95	1.328745	1.435109	1.583730	1.686656	1.825916
1.00	1.335406	1.444745	1.598217	1.704989	1.850095
Mean	1.225148	1.292221	1.381966	1.441651	1.519494
1st mom.	0.636634	0.678670	0.735817	0.774378	0.825317

TABLE 8-3. Continued

μ	$\tilde{\omega} = 0.92$	$\tilde{\omega} = 0.94$	$\tilde{\omega} = 0.96$	$\tilde{\omega} = 0.98$	$\tilde{\omega} = 0.99$
0.00	1.000000	1.000000	1.000000	1.000000	1.000000
0.05	1.104330	1.109161	1.114731	1.121700	1.126408
0.10	1.180588	1.190025	1.201077	1.215196	1.224940
0.15	1.247339	1.261434	1.278137	1.299801	1.314988
0.20	1.307860	1.326672	1.349186	1.378764	1.399768
0.25	1.363707	1.387286	1.415750	1.453571	1.480738
0.30	1.415788	1.444169	1.478699	1.525056	1.558707
0.35	1.464702	1.497907	1.538598	1.593750	1.634178
0.40	1.510876	1.548914	1.595842	1.660019	1.707496
0.45	1.554634	1.597502	1.650726	1.724130	1.778906
0.50	1.596228	1.643917	1.703480	1.786286	1.848594
0.55	1.635867	1.688357	1.754287	1.846650	1.916703
0.60	1.673720	1.730986	1.803301	1.905354	1.983349
0.65	1.709935	1.771944	1.850652	1.962507	2.048627
0.70	1.744637	1.811351	1.896449	2.018205	2.112617
0.75	1.777935	1.849314	1.940791	2.072528	2.175388
0.80	1.809926	1.885924	1.983763	2.125549	2.236997
0.85	1.840696	1.921266	2.025441	2.177330	2.297498
0.90	1.870323	1.955413	2.065896	2.227929	2.356936
0.95	1.898876	1.988434	2.105188	2.277398	2.415353
1.00	1.926417	2.020389	2.143376	2.325784	2.472787
Mean	1.559038	1.606492	1.666667	1.752201	1.818182
1st mom.	0.851467	0.883087	0.923548	0.981749	1.027182

TABLE 8-3. Concluded

μ	$\tilde{\omega} = 0.995$	$\tilde{\omega} = 0.999$
0.00	1.000000	1.000000
0.05	1.129618	1.133736
0.10	1.231690	1.240491
0.15	1.325628	1.339664
0.20	1.414627	1.434417
0.25	1.500122	1.526160
0.30	1.582903	1.615664
0.35	1.663460	1.703400
0.40	1.742120	1.789679
0.45	1.819117	1.874719
0.50	1.894621	1.958680
0.55	1.968765	2.041679
0.60	2.041654	2.123810
0.65	2.113372	2.205145
0.70	2.183989	2.285743
0.75	2.253563	2.365652
0.80	2.322145	2.444913
0.85	2.389778	2.523558
0.90	2.456500	2.601616
0.95	2.522344	2.679111
1.00	2.587341	2.756066
Mean	1.867918	1.938693
1st mom.	1.061731	1.111331

Chapter 9

Additional Topics

There are a great number of problems contained in radiative transfer theory that were not addressed at all in these notes. We will mention just a few of these here as a conclusion to the text, describe them briefly, and indicate some references which perhaps address them more thoroughly.

Determination of Optical Parameters

All of the methods discussed in the text have assumed that the optical parameters used in the equations, such as optical depth, phase function, asymmetry parameter, single-scattering albedo, etc., were all known. These parameters can be computed to an acceptable degree of accuracy, in most cases, by the use of well established numerical or theoretical methods or both. The complete repertoire of procedures again consists of both "exact" and approximate methods, but unfortunately, it would take another text larger than the present one to describe them in sufficient detail.

For homogeneous atmospheres, the optical depth can be computed for a single frequency and along a given slant path with little difficulty. Unfortunately, all measuring devices measure radiation in a finite band of frequencies, with a variable response across the band. The absorption coefficient varies very rapidly with frequency, and at a single frequency, many tens of nearby lines may contribute to the monochromatic absorption coefficient. Thus, a great deal of data concerning the positions of line centers, line strengths, and line shapes must be available. Additionally, since the lines are generally spaced such that they overlap to varying degrees, a very fine grid spacing in wavelength must be used to get the total absorption in a given finite bandwidth. This problem is further complicated by the fact that the line optical parameters vary strongly with altitude (i.e., pressure and temperature) and with frequency, and hence, the absorption changes in a strongly nonlinear fashion with these parameters. As a result, generally three nontrivial

integrations are required to completely describe the absorption characteristics of radiation; i.e., over wavelength, angle, and altitude.

Band models attempt to reduce the frequency integration to a tractable problem. Some assumptions concerning the distribution of line centers and the distribution of line strengths are made to reduce the frequency integral to one which can be evaluated in terms of elementary functions. This scheme has produced a number of popular band models which have been used in a number of atmospheric physics applications, such as climate modeling and studies of the thermal structure of the atmosphere. Three excellent references for band model derivations and applications are those by Goody (1964), Rodgers (1976), and Anding (1969).

The scattering optical properties can also be determined, at least for spherical particles. The scatter properties of particles which are very small relative to the wavelength of the incident radiation (i.e., molecular scattering) can be accurately described by the Rayleigh theory (Liou, 1980, van de Hulst, 1957), while for very large particles, ray tracing techniques are generally used (Liou, 1980). Particles in the intermediate size range are the ones which cause most of the computational problems. The most general theory here is the Mie theory (Liou, 1980, van de Hulst, 1957, Stratton, 1947). However, as stated earlier, this theory is complete only for spherical particles, although some success with cylinders and flat plate particles has been reported (Liou, 1980, van de Hulst, 1957, Kerker, 1969). The optical properties such as phase function, and scatter and absorption cross sections are functions of only two parameters—the ratio of the wavelength of the incident light to the particle radius, and the complex index of refraction of the material from which the particles are made—and are independent of pressure and temperature.

If the particle size distribution is known (number density of particles as a function of particle radius, for example), the overall properties of a unit volume of scatterers (polydispersion) can be computed (Liou, 1980, Deirmendjian, 1969). Since both the total number of particles per unit volume and their size distribution may in general vary with altitude, there is thus a strong altitude dependence built into the scattering properties of a polydispersed conglomerate of particles.

As mentioned above, these computational procedures are well defined and are used extensively in the literature, although the computational details are quite involved and time consuming, and in some cases tax even the most modern of high-speed computers.

Some approximations to the Mie results have been reported in the literature, and may be profitably used in studies in which the ultimate in accuracy is not needed—e.g., in studies of climate modeling and the

effects of aerosols on global climate (van de Hulst, 1957, Penndorf, 1962, Plass, 1966).

Finite Homogeneous Atmospheres

The discrete ordinates method (chap. 7) and the principle of invariance (chap. 8), as discussed in the text, are applicable only to semi-infinite homogeneous atmospheres with isotropic scattering. Chandrasekhar (1960) and Sobolev (1975) extend these techniques in elegant mathematical fashion to finite homogeneous atmospheres with arbitrary (to some extent) phase functions.

The principle of invariance can be simply stated for a finite atmosphere. If we add an infinitely thin layer of the same optical properties to the *top* of a finite atmosphere, then the changes in the reflection function and the transmission function for this incremented atmosphere can be computed. Similarly, if we add an infinitely thin layer to the *bottom* of the atmosphere, these changes can again be computed. The two sets of change must be equal; equating them, one arrives at two coupled nonlinear integro-differential equations for the reflection and transmission functions for the finite atmosphere, equations quite similar to equation (8-10). By rearranging terms and factoring as we did earlier, two functions can be defined which are similar in utility to the H -functions. These are the famous X - and Y -functions of Chandrasekhar, which describe the reflection and transmission of isotropic radiation in finite atmospheres. Further manipulation yields a coupled set of integral equations for these functions similar to equation (8-17). Then the angular distribution of the radiant energies from both the top and the bottom of the atmosphere can be described in equations similar to equation (7-84).

The X - and Y -functions can be computed and tabulated (see Chandrasekhar), just as we did for the H -functions, for specific phase functions.

As the thickness of the finite atmosphere increases, approaching the semi-infinite case, the X -function approaches the H -function and the Y -function goes to zero. Thus, the X -function is related to the reflection properties of the finite atmosphere, while the Y -function is related to its transmission properties.

For very thin atmospheres, the X -function approaches unity and the Y -function approaches $e^{-\tau^*}/\mu_0$, and the resultant equations for the radiance reduce to the single-scattering solution we found in chapter 5.

Anisotropic Scattering

In chapter 1 it was pointed out that the phase function can in many cases be described by a Legendre polynomial expansion in the scattering

angle. In both the semi-infinite and finite atmospheres, if this is done and the principle of invariance applied, the result is one (for semi-infinite atmospheres) or two (for finite atmospheres) integral equations for an H -function or for the X - and Y -functions, for *each term* of the Legendre expansion, and these are in general horribly coupled. The numerical problems thus generated are so enormous, that, to this writer's knowledge, no one has generated general tables of these functions except for isotropic scattering and some limited results for Rayleigh scattering. However, even for the relatively simple cases of the two-term expansion and the two-term Rayleigh expansion, the computational difficulties are such that even Chandrasekhar only presents a limited number of numerical tables.

Similarity may be applied in some cases. However, in general some other numerical technique, such as the adding or doubling methods to be described later, is usually used. The discrete ordinates method, and the related spherical harmonics methods, have been successfully applied numerically in some limited cases, even for nonhomogeneous atmospheres, but it is generally conceded that the other procedures are numerically and computationally superior for these applications.

Effect of Surface Albedo

In our analysis of the inclusion of surface effects in chapter 4, it was assumed that the reflective surface was Lambertian (i.e., isotropic scatter from the surface) and was the same for all parts of the surface plane. This is in general not a realistic approximation, but again the numerical results may be accurate enough for some applications. Little work has been done on other than Lambertian surfaces, but some results are available for specularly reflecting surfaces. See the thesis by Tanré and the paper by Deschamps et al. in Deepak, 1980.

Other Computational Techniques

There are a number of so-called "exact" methods available in the literature, which are comparable to or somewhat better than the discrete ordinates method for nonisotropic scattering. These methods are exact in the sense of some limiting process as described with the discrete ordinates method covered in chapter 7. A few of these methods will be discussed in this subsection.

Adding and doubling methods. These methods are similar and are both based on the following premise: suppose we have two slabs of optically active material, and suppose that we know the reflective and transmission properties of each slab separately. If we place the two slabs together, face to face, then by considering the multiple transmissions and

reflections between the two slabs, it is possible to determine the overall transmission and reflective properties of the composite slab considered as a unit. In its most fundamental form, we can show this as follows in figures 9-1 and 9-2, where the slabs are shown separated for clarity only. We let the reflectance and transmission coefficients be denoted by R and T , respectively, with subscript 1 referring to the upper slab and subscript 2 referring to the lower.

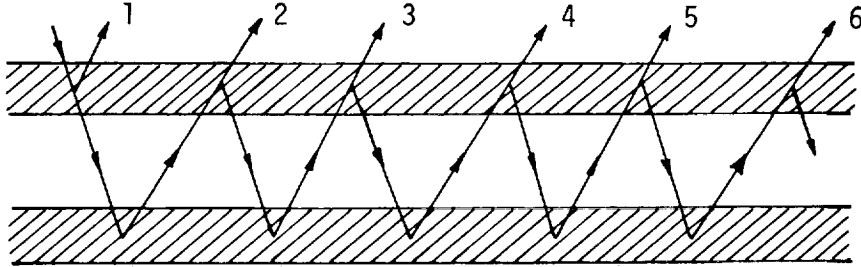

Figure 9-1. Illustration of the various orders of scattering between two finite thick layers. The layers are shown separated for clarity only.

The following rays emerge from the top of the composite slab:

1. Ray 1 is simply the reflection from the upper slab, R_1 .
2. Ray 2 is a ray transmitted through the upper slab, reflected from the lower slab, and transmitted through the upper slab, $T_1 R_2 T_1$.
3. Ray 3 is transmitted through 1, reflected from 2, reflected back down from 1, reflected again from 2, and transmitted out through 1, $T_1 R_2 R_1 R_2 T_1$.
4. For the remaining rays, there are similar multiple reflections between 1 and 2 and transmissions through 1.

Collect all these together, and we have for the total reflection from the top of layer 1

$$R_{12} = R_1 + T_1 R_2 T_1 + T_1 R_2 R_1 R_2 T_1 + T_1 R_2 R_1 R_2 R_1 R_2 T_1 + \dots$$

and these can be collected to give

$$R_{12} = R_1 + T_1 R_2 T_1 (1 + R_1 R_2 + R_1^2 R_2^2 + \dots)$$

Since $R_1 R_2 < 1$ we can write this last as

$$R_{12} = R_1 + \frac{R_1 T_1^2}{1 - R_1 R_2} \quad (9-1)$$

Transmission is handled the same way, as shown in figure 9-2, and the composite transmission function can be written

$$\begin{aligned}
 T_{12} &= T_1 T_2 + T_1 R_2 R_1 T_2 + T_1 R_2 R_1 R_2 R_1 T_2 + \dots \\
 &= T_1 T_2 (1 + R_1 R_2 + R_1^2 R_2^2 + \dots)
 \end{aligned}$$

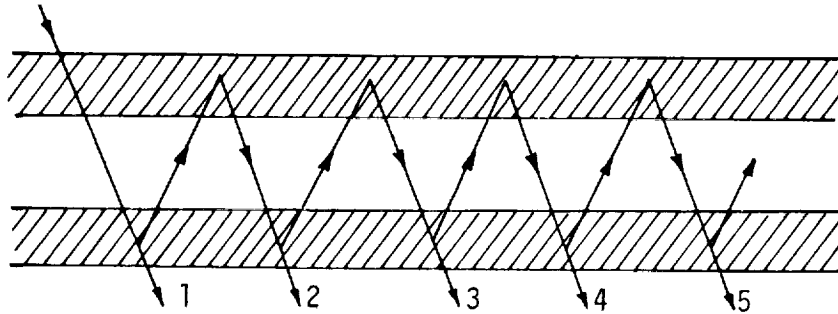

Figure 9-2. Same as figure 9-1 except showing the various orders of scattering involved in diffuse transmission.

or

$$T_{12} = \frac{T_1 T_2}{1 - R_1 R_2} \tag{9-2}$$

The similarity between equation (9-1) and equation (4-39) or equation (4-40) cannot have escaped the reader's attention.

In more realistic application, the order of multiplication in equations (9-1) and (9-2) must be preserved, and the simple products are replaced by integral functions over all directions (see, e.g., Liou, 1980). Another approach is to construct the R and T as matrices whose elements are in general integrals of sundry combinations of the directional representations of the reflection and transmission coefficients. This approach is directly oriented toward computer application; see, for example, the excellent paper by Twomey, Jacobowitz, and Howell (1966); see also van de Hulst (1963), the highly mathematical series of papers by Grant and Hunt (1968a, 1968b, 1969), and the paper by Hunt and Grant (1969).

Both the adding and the doubling methods use the generalized form of equations (9-1) and (9-2).

The doubling method is applicable to homogeneous atmospheres. A very thin slab is selected, say $\Delta\tau = 2 \times 10^{-20}$ or so, and the reflection and transmission coefficients are computed by one of the thin-atmosphere solutions covered in chapter 5, say the thin-atmosphere

solutions, equations (5-16) and (5-19). Now, if we assume two slabs of the same thickness and same R and T , then the generalized forms of equations (9-1) and (9-2) can be used to compute R and T for the thickness $2 \Delta\tau$. These R and T then can be used in turn to compute a pair of R and T for a thickness $4 \Delta\tau$, $8 \Delta\tau$, etc., doubling the thickness with each application of equations (9-1) and (9-2) until the desired total optical thickness is reached. Obviously, the doubling method can only be used for homogeneous optical slabs.

The adding method is similar and can be used for inhomogeneous atmospheres. Suppose the inhomogeneous layer is divided into a number of thin layers, and the thin-atmosphere solution (or indeed, the doubling method!) is used to compute the R and T for each layer separately. Then, the appropriate forms of equations (9-1) and (9-2) can be used to get R_{12} and T_{12} . Then the third layer can be added to this to yield R_{123} and T_{123} , and then the fourth and succeeding layers until the entire atmosphere is completed. Liou (1980) presents some very useful tables of reflection and transmission coefficients computed from both the discrete ordinates method and the doubling method.

Coakley, Cess, and Yurevich (1983) present an interesting method of using reflection and transmission coefficients computed from the delta-Eddington method with the adding and doubling methods.

The spherical harmonics method. The spherical harmonics method is very similar to the discrete ordinates method; in fact, the discrete ordinates method is a specialized form of the spherical harmonics method. In this method, shown here for the azimuthally symmetric case, it is assumed that the intensity itself as well as the phase function can be expanded in a series of Legendre polynomials

$$I(\tau, \mu) = \sum_{m=0}^N \frac{2m+1}{4\pi} P_m(\mu) \psi_m(\tau) \quad (9-3)$$

where the $\psi_m(\tau)$ are coefficients which are functions of τ only, and the phase function is expanded as

$$P(\mu, \mu') = \sum_{n=0}^N (2n+1) f_n P_n(\mu) P_n(\mu') \quad (9-4)$$

After substituting into the RTE and simplifying, one gets a system of differential equations for the $\psi_m(\tau)$,

$$\begin{aligned} (m+1)\frac{d\psi_{m+1}}{d\tau} + m\frac{d\psi_{m-1}}{d\tau} + (2m-1)(1-\tilde{\omega}f_m)\psi_m \\ = 4\pi(1-\tilde{\omega})B(T)\delta_0m \quad (f_0=1) \end{aligned} \quad (9-5)$$

where $B(T)$ is the Planck function. For isotropic scattering, all the $f_m = 0$ except for $f_0 = 1$. If one retains N terms of the expansion equation (9-3) (the P_n -approximation), then equation (9-5) yields a set of $N + 1$ simultaneous, linear ordinary differential equations for the $\psi_0, \psi_1, \dots, \psi_n$ (ψ_{n+1} is set to zero), which when substituted back into equation (9-3), give the intensity at any τ, μ .

The boundary conditions for the P_n -method are difficult to satisfy exactly, and in general some approximation must be used. We have seen this earlier in connection with the Eddington method, and in fact the spherical harmonics method with $N = 0$ and $N = 1$ yields precisely the Eddington equations. See Özisik (1973) for an elementary discussion of the P_n -method and for some schemes for handling the boundary conditions. See also the discussions in Kourganoff (1963) and Lenoble (1977).

Monte Carlo method. This is perhaps the only method known which can be applied to *any* radiative transfer problem regardless of asymmetry, nonhomogeneity, or any other anomaly, and is the only method which can really be called "exact." However, as in other applications, there is no "free lunch," and one must pay a heavy price in computer costs—mostly time—for this flexibility and general utility.

Basically, in the Monte Carlo method one injects a series of single photons into the medium and follows one photon at a time in space and time as it travels through the three-dimensional medium. Whenever the photon encounters an absorber or scatterer, a suitable probability is used to determine whether an actual interaction occurs and what type. If the interaction is an absorption, the computations stop here and the energy of the photon is used to increment the total energy of the medium, and another photon is injected into the medium and followed. If the interaction is a scattering, the direction into which the photon is scattered is determined probabilistically from the phase function. The photon is followed through ensuing scatterings or absorptions or until it escapes through the top of the atmosphere. It is apparent that a great many photons must be tracked (orders of hundreds of thousands) to provide a reliable sample size from which to determine reflection, transmission, and absorption distributions, and therefore a great deal

of computer time is required. A number of computational schemes have evolved to shorten the computational time and retain the accuracy of this method, but the expense has precluded its wide application for radiative transfer studies. Its utility seems to be in the areas where absolutely nothing else works, and to provide some limited benchmark results against which to compare the results of more rapid but perhaps less precise analyses.

See the most interesting discussions of this method in Irvine and Lenoble (1973) and in the paper by Hansen and Travis (1974). The papers by Kattawar and Plass (1968) and Plass and Kattawar (1968) best describe the application of this method to radiative transfer problems.

There are, of course, many other methods not mentioned here for solving the RTE to greater or lesser degrees of approximation. These include the method of successive orders of scattering, which is an extension of the single-scatter method derived in chapter 5, the eigenvalue expansion method of Case, the Gauss-Seidel method (a numerical technique), and many others. Some of these are briefly discussed in Irvine and Lenoble (1973), where specific references are given, as well as in the paper by Hansen and Travis (1974), and the text by Özisik (1973). A much more comprehensive discussion is given in Lenoble (1977), with many references and the basic equations.

Non-Homogeneous Atmospheres

Practically all of the methods discussed in the present text are restricted to solutions in a homogeneous atmosphere. There has been much more effort expended in applying these methods approximately to nonhomogeneous atmospheres. What is generally done is to divide the atmosphere into a number of thin layers and treat each layer by, for example, the discrete ordinates method. The main difference between this technique and the approach we have taken is in the application of the boundary conditions. Here, one can use the zero diffuse radiation boundary condition only at the top of the uppermost layer and at the bottom of the lowest layer. In between, the boundary conditions must be set up to insure continuity of flux or energy *across* each boundary. This procedure generally leads to a set of simultaneous algebraic equations which must be solved for a set of constant coefficients for each layer considered (e.g., the constants A and B of equations (5-69) and (5-70) would be different in each layer). Liou (1973) has done this using the discrete ordinates method, and Wiscombe (1977) has used the delta-Eddington method in the same way. Comparisons with the more nearly exact adding method indicate that good accuracy can be obtained with these schemes.

Other Problems

Finally, there are many other problems in radiative transfer theory which are seldom mentioned in the literature. There is, for example, the inclusion of horizontal inhomogeneities in the plane-parallel atmosphere we have been using (e.g., finite clouds or actual differences in optical properties due to climatic or meteorological effects), or the revision of the plane-parallel assumption itself, i.e., considering spherical atmospheres. Some of these problems have been addressed by neutron physicists, since the travel of neutrons through absorbing and scattering media is described by an equation very similar to our radiative transfer equations—the main difference being that the neutrons can travel with different speeds, while our photons all travel at the speed of light.

Other problems include the *shadow effect*, in which the shadowing of one particle by another prevents the second particle from interacting fully with the incident field—it is shielded to some extent by the particles in front of it. This can occur, according to van de Hulst (1957), if the mean spacing between particles becomes less than four or five particle diameters. This problem practically never arises in atmospheric applications of radiative transfer theory, but can arise in neutron theory.

Another major problem area, which just over the last ten years or so has begun to receive attention in the literature, is the problem of the transfer of *polarized* radiation components and their use in studying the properties of atmospheric components, and particularly in the study of radiation from the surface of the oceans and clouds. In most cases, this can be handled both numerically and analytically by replacing the scalar equation we have been using with a vector equation; i.e., the intensity scalar becomes a four-component vector whose components are usually the *Stokes* parameters (see Deirmendjian, 1969, van de Hulst, 1957, Hansen and Travis, 1974), and the phase function becomes a 4×4 phase *matrix*, whose components characterize the polarization produced by a single act of scattering. Many of the numerical techniques discussed in this chapter (adding, doubling, etc.) can be used to analyze polarized fields, but little analytic work has been done in this area (see Irvine and Lenoble, 1973, and Lenoble, 1977). Polarization for Rayleigh scattering has been considered by Chandrasekhar (1960), and some work has been done by Sekera (see Lenoble, 1977).

References

- Abramowitz, Milton; and Stegun, Irene A., eds.: *Handbook of Mathematical Functions*. Dover Publ., Inc., 1970.
- Acquista, Charles; House, Frederick; and Jafolla, James: N-Stream Approximations to Radiative Transfer. *J. Atmos. Sci.*, vol. 38, July 1981, pp. 1446-1451.
- Ambartsumyan, V. A., ed. (J. B. Sykes, transl.): *Theoretical Astrophysics*. Pergamon Press, Inc., c.1958.
- Anding, David: Band-Model Methods for Computing Atmospheric Slant-Path Molecular Absorption and Emission: A Course in Infrared Detection. Univ. of Michigan, 1969.
- Buglia, James J.: *A Tutorial Solution to Scattering of Radiation in a Thin Atmosphere Bounded Below by a Diffusely Reflecting, Absorbing Surface*. NASA TP-2077, 1982.
- Chandrasekhar, S.: *Radiative Transfer*. Dover Publ., Inc., c.1960.
- Coakley, James A., Jr.; and Chylek, Petr: The Two-Stream Approximation in Radiative Transfer: Including the Angle of the Incident Radiation. *J. Atmos. Sci.*, vol. 32, no. 2, Feb. 1975, pp. 409-418.
- Coakley, James A., Jr.; Cess, Robert D.; and Yurevich, Franz B.: The Effect of Tropospheric Aerosols on the Earth's Radiation Budget: A Parameterization for Climate Models. *J. Atmos. Sci.*, vol. 40, no. 1, Jan. 1983, pp. 116-138.
- Deepak, Adarsh, ed.: *Remote Sensing of Atmospheres and Oceans*. Academic Press, Inc., 1980.
- Deirmendjian, D.: *Electromagnetic Scattering on Spherical Polydispersions*. American Elsevier Pub. Co., 1969.
- Goody, R. M.: *Atmospheric Radiation. I: Theoretical Basis*. Oxford Univ. Press, 1964.
- Grant, I. P.; and Hunt, G. E.: Solution of Radiative Transfer Problems Using the Invariant S_n Method. *Mon. Not. R. Astron. Soc.*, vol. 141, no. 1, 1968a, pp. 27-41.

Introduction to the Theory of Atmospheric Radiative Transfer

- Grant, I. P.; and Hunt, G. E.: Solution of Radiative Transfer Problems in Planetary Atmospheres. *Icarus*, vol. 9, no. 3, Nov. 1968b, pp. 526-534.
- Grant, I. P.; and Hunt, G. E.: Discrete Space Theory of Radiative Transfer. Parts I and II - Fundamentals, Stability and Non-Negativity. *Proc. R. Soc. London*, vol. 313, no. 1513, Oct. 21, 1969, pp. 183-197 and 199-216.
- Hansen, James E.; and Travis, Larry D.: Light Scattering in Planetary Atmospheres. *Space Sci. Rev.*, vol. 16, no. 4, Oct. 1974, pp. 527-610.
- Hunt, G. E.; and Grant, I. P.: Discrete Space Theory of Radiative Transfer and Its Application to Problems in Planetary Atmospheres. *J. Atmos. Sci.*, vol. 26, no. 5, pt. 1, Sept. 1969, pp. 963-972.
- Irvine, William M.: Multiple Scattering by Large Particles. II. Optically Thick Layers. *Astron. J.*, vol. 152, no. 3, pt. 1, June 1968, pp. 823-834.
- Irvine, William M.: Multiple Scattering in Planetary Atmospheres. *Icarus*, vol. 25, no. 2, June 1975, pp. 175-204.
- Irvine, William M.; and Lenoble, J.: Solving Multiple Scattering Problems in Planetary Atmospheres. Proceedings - The UCLA International Conference on Radiation and Remote Probing of the Atmosphere, Jacob G. Kuriyan, ed., Dep. Meteorol., Univ. of California, Aug. 1973, pp. 1-57.
- Joseph, J. H.; Wiscombe, W. J.; and Weinman, J. A.: The Delta-Eddington Approximation for Radiative Flux Transfer. *J. Atmos. Sci.*, vol. 33, no. 12, Dec. 1976, pp. 2452-2459.
- Kattawar, George W.; and Plass, Gilbert N.: Radiance and Polarization of Multiple Scattered Light From Haze and Clouds. *Appl. Opt.*, vol. 7, no. 8, Aug. 1968, pp. 1519-1527.
- Kerker, M.: *The Scattering of Light and Other Electromagnetic Radiation*. Academic Press, Inc., 1969.
- Kourganoff, V.: *Basic Methods in Transfer Problems*. Dover Publ., Inc., c.1963.
- Lenoble, Jacqueline, ed.: *Standard Procedures To Compute Atmospheric Radiative Transfer in a Scattering Atmosphere*. International Association of Meteorology and Atmospheric Physics (IAMAP) Radiation Commission, July 1977.
- Liou, Kuo-Nan: Transfer of Solar Irradiance Through Cirrus Cloud Layers. *J. Geophys. Res.*, vol. 78, no. 9, Mar. 20, 1973, pp. 1409-1418.

- Liou, Kuo-Nan: *An Introduction to Atmospheric Radiation*. Academic Press, Inc., 1980.
- Lyzenga, D. R.: Note on the Modified Two-Stream Approximation of Sagan and Pollack. *Icarus*, vol. 19, no. 2, June 1973, pp. 240-243.
- Meador, W. E.; and Weaver, W. R.: Two-Stream Approximations to Radiative Transfer in Planetary Atmospheres: A Unified Description of Existing Methods and a New Improvement. *J. Atmos. Sci.*, vol. 37, no. 3, Mar. 1980, pp. 630-643.
- Özsisik, M. Necati: *Radiative Transfer*. John Wiley & Sons, Inc., c.1973.
- Penndorf, Rudolf B.: Scattering and Extinction Coefficients for Small Absorbing and Nonabsorbing Aerosols. *J. Opt. Soc. America*, vol. 52, no. 8, Aug. 1962, pp. 896-904.
- Plass, Gilbert N.: Mie Scattering and Absorption Cross Sections for Absorbing Particles. *Appl. Opt.*, vol. 5, no. 2, Feb. 1966, pp. 279-285.
- Plass, Gilbert N.; and Kattawar, George W.: Monte Carlo Calculations of Light Scattering From Clouds. *Appl. Opt.*, vol. 7, no. 3, Mar. 1968, pp. 415-419.
- Rodgers, C. D.: *Approximate Methods of Calculating Transmission by Bands of Spectral Lines*. NCAR/TN-116+1A (Contract NSF C-760), Mar. 1976. (Available from NTIS as PB 252 367.)
- Rodgers, C. D.; and Walshaw, C. D.: The Computation of Infra-Red Cooling Rate in Planetary Atmospheres. *Q. J. R. Meteorol. Soc.*, vol. 92, no. 391, Jan. 1966, pp. 67-92.
- Sagan, Carl; and Pollack, James B.: Anisotropic Nonconservative Scattering and the Clouds of Venus. *J. Geophys. Res.*, vol. 72, no. 2, Jan. 1967, pp. 469-477.
- Sobolev, V. V. (William M. Irvine, transl.): *Light Scattering in Planetary Atmospheres*. Pergamon Press, c.1975.
- Sparrow, E. M.; and Cess, R. D.: *Radiation Heat Transfer*. Brooks/Cole Pub. Co., c.1966.
- Stratton, Julius Adams: *Electromagnetic Theory*. McGraw-Hill Book Co., Inc., 1941.
- Tanré, Didier: Interaction Rayonnement - Aerosols Applications à la Teledetection et au Calcul du Bilan Radiatif. Docteur des Sciences Physiques Thèse, L'Université des Sciences et Techniques de Lille (France), Mar. 1982.
- Twomey, S.; Jacobowitz, H.; and Howell, H. B.: Matrix Methods for Multiple-Scattering Problems. *J. Atmos. Sci.*, vol. 23, no. 3, May 1966, pp. 289-296.

Introduction to the Theory of Atmospheric Radiative Transfer

- Wiscombe, W. J.: *The Delta-Eddington Approximation for a Vertically Inhomogeneous Atmosphere*. NCAR/TN-121+STR (Contract ATM 72-10157), July 1977. (Available from NTIS as PB 270 618.)
- Wiscombe, W. J.; and Grams, G. W.: The Backscattered Fraction in Two-Stream Approximations. *J. Atmos. Sci.*, vol. 33, no. 12, Dec. 1976, pp. 2440-2451.
- Van de Hulst, H. C.: *Light Scattering by Small Particles*. John Wiley & Sons, Inc., c.1957.
- Van de Hulst, H. C.: A New Look at Multiple Scattering. NASA Goddard Institute for Space Studies, Goddard Space Flight Center (New York, N.Y.), Jan. 1963.

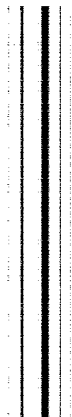



1. Report No. NASA RP-1156	2. Government Accession No.	3. Recipient's Catalog No.	
4. Title and Subtitle Introduction to the Theory of Atmospheric Radiative Transfer		5. Report Date July 1986	
		6. Performing Organization Code 619-12-30-21	
7. Author(s) James J. Buglia		8. Performing Organization Report No. L-16068	
9. Performing Organization Name and Address NASA Langley Research Center Hampton, VA 23665-5225		10. Work Unit No.	
		11. Contract or Grant No.	
12. Sponsoring Agency Name and Address National Aeronautics and Space Administration, Washington, DC 20546-0001		13. Type of Report and Period Covered Reference Publication	
		14. Sponsoring Agency Code	
15. Supplementary Notes			
16. Abstract The fundamental physical and mathematical principles governing the transmission of radiation through the atmosphere are presented, with emphasis on the scattering of visible and near-IR radiation. The classical two-stream, thin-atmosphere, and Eddington approximations, along with some of their offspring, are developed in detail, along with the discrete ordinates method of Chandrasekhar. The adding and doubling methods are discussed from basic principles, and references for further reading are suggested.			
17. Key Words (Suggested by Author(s)) Radiation transfer Scattering Two-stream Eddington Discrete ordinates		18. Distribution Statement Unclassified - Unlimited Subject Category 46	
19. Security Classif. (of this report) Unclassified	20. Security Classif. (of this page) Unclassified	21. No. of Pages 175	22. Price A08

For sale by the National Technical Information Service, Springfield, Virginia 22161

NASA-Langley, 1986