

1N-37

67 pages

5105-146
Solar Thermal Power Systems Project
Parabolic Dish Systems Development

DOE/JPL-1060-92
Distribution Category UC-62

Bearing Development Program for a 25-kWe Solar-Powered Organic Rankine-Cycle Engine

B. Nesmith

1N-14296

(NASA-CR-177156) BEARING DEVELOPMENT
PROGRAM FOR A 25 kWe SOLAR-POWERED ORGANIC
RANKINE-CYCLE ENGINE (Jet Propulsion Lab.)
67 p HC A04/MF A01
N86-28432
CSSL 13I
Unclas
G3/37 43403



September 15, 1985

Prepared for
U.S. Department of Energy
Through an Agreement with
National Aeronautics and Space Administration
by
Jet Propulsion Laboratory
California Institute of Technology
Pasadena, California

JPL Publication 85-81

5105-146
Solar Thermal Power Systems Project
Parabolic Dish Systems Development

DOE/JPL-1060-92
Distribution Category UC-62

Bearing Development Program for a 25-kWe Solar-Powered Organic Rankine-Cycle Engine

B. Nesmith

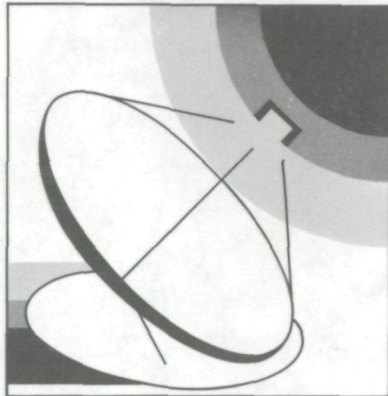

September 15, 1985

Prepared for
U.S. Department of Energy
Through an Agreement with
National Aeronautics and Space Administration
by
Jet Propulsion Laboratory
California Institute of Technology
Pasadena, California

JPL Publication 85-81

Prepared by the Jet Propulsion Laboratory, California Institute of Technology,
for the U.S. Department of Energy through an agreement with the National
Aeronautics and Space Administration.

This report was prepared as an account of work sponsored by an agency of the
United States Government. Neither the United States Government nor any
agency thereof, nor any of their employees, makes any warranty, express or
implied, or assumes any legal liability or responsibility for the accuracy, com-
pleteness, or usefulness of any information, apparatus, product, or process
disclosed, or represents that its use would not infringe privately owned rights.

Reference herein to any specific commercial product, process, or service by trade
name, trademark, manufacturer, or otherwise, does not necessarily constitute or
imply its endorsement, recommendation, or favoring by the United States
Government or any agency thereof. The views and opinions of authors
expressed herein do not necessarily state or reflect those of the United States
Government or any agency thereof.

ABSTRACT

This report summarizes the bearing development program for a 25-kWe power conversion subsystem (PCS) consisting of an organic Rankine-cycle engine, permanent magnet alternator (PMA) and rectifier to be used in a 100-kWe point-focusing distributed receiver solar power plant. The engine and alternator were hermetically sealed and used toluene as the working fluid. The turbine, alternator, and feed pump (TAP) were mounted on a single shaft operating at speeds up to 60,000 rev/min. Net thermal-to-electric efficiencies in the range of 21 to 23% were demonstrated at the maximum working fluid temperature of 400°C (750°F).

A chronological summary of the bearing development program is presented. The primary causes of bearing wear problems were traced to a combination of rotordynamic instability and electrodynamic discharge across the bearing surfaces caused by recirculating currents from the PMA. These problems were resolved by implementing an externally supplied, flooded-bearing lubrication system and by electrically insulating all bearings from the TAP housing. This program resulted in the successful development of a stable, high-speed, toluene-lubricated five-pad tilting-pad journal bearing and Rayleigh step thrust bearing system capable of operating at all inclinations between horizontal and vertical.

ACKNOWLEDGMENT

The design, fabrication, development, and test of this power conversion subsystem (PCS) was completed under the direction of the following persons:

T. Kiceniuk	Jet Propulsion Laboratory	Manager, Small Community Solar Thermal Power Experiment
B. Nesmith	Jet Propulsion Laboratory	Cognizant Engineer, Receiver/PCS
F. Boda	Ford Aerospace and Communications Corp.	Cognizant Engineer, PCS
R. Barber	Barber-Nichols (B-N)	Project Manager, PCS
R. Blakemore	Barber-Nichols	Project Engineer, PCS

Special recognition goes to the engineers and technicians of B-N who were responsible for the design, fabrication, and test of the organic Rankine-cycle (ORC) engine. J. Anderson provided valuable analysis and recommendations throughout the program in the areas of bearing design and lubrication. D. Pautz (Waukesha) provided design support for the five-pad tilting-pad journal bearings that were ultimately selected and also provided insight into the electrodynamic discharge phenomenon. Other contributors in the development of rotor bearing systems included A.J. Acosta and T.K. Caughey (California Institute of Technology); R.L. Hamm and S.B. Malanoski (Mechanical Technology, Inc.); and N.F. Rieger (Stress Technology, Inc.).

The successful completion of this development program would not have been possible without these individuals and numerous other subcontractors and laboratory personnel.

The work described herein was conducted by the Jet Propulsion Laboratory, California Institute of Technology, for the U.S. Department of Energy through an agreement with the National Aeronautics and Space Administration (NASA Task RE-152, Amendment 327; DOE/ALO/NASA Interagency Agreement No. DE-AM04-80AL13137).

In memory of
Frank P. Boda,
a special friend and co-worker

CONTENTS

I. INTRODUCTION 1-1

II. ORIGINAL BEARING DESIGN AND DEVELOPMENT MODIFICATIONS 2-1

III. BEARING TESTS IN THE COMPLETED POWER CONVERSION SUBSYSTEM 3-1

IV. POWER CONVERSION ASSEMBLY AND INVERTER TESTS 4-1

V. ON-SUN POWER CONVERSION ASSEMBLY AND UTILITY INTERFACE
SYSTEM TESTS AT THE PARABOLIC DISH TEST SITE 5-1

VI. SECOND-GENERATION BEARING TEST STAND RESULTS 6-1

VII. TAP TEST STAND COMPONENT PERFORMANCE EVALUATION 7-1

VIII. COMPLETE POWER CONVERSION SUBSYSTEM 100-h TEST
AT BARBER-NICHOLS 8-1

IX. CONCLUSIONS 9-1

X. REFERENCES 10-1

PRECEDING PAGE BLANK NOT FILMED

SECTION I

INTRODUCTION

The Small Community Solar Thermal Power Experiment (SCSE) was an engineering experiment funded by the U.S. Department of Energy (DOE) and monitored by the Jet Propulsion Laboratory (JPL) with the purpose of designing, deploying, and gathering technical information on a 100-kWe solar thermal power plant. Ford Aerospace and Communications Corporation (FACC) was selected as the system integrator at the conclusion of the Phase I study contract with their parabolic dish collector and focus-mounted engine/alternator concept. The SCSE Phase II contract called for the design, development, installation, and test of a single module consisting of a parabolic dish collector and power conversion subsystem (PCS). SCSE Phase III specified construction and operation of a four-module 100-kWe plant located in Osage City, Kansas.

The concentrator selected was a 12-m-diameter altitude over azimuth mounted parabolic dish designed by General Electric (GE) and eventually fabricated by FACC. This type of tracking design made it necessary for the rotor bearing system to operate between 5- and 90-deg altitude angles. The concentrator was designed to deliver a maximum thermal input of 92.4 kWt (direct normal insolation = 1100 W/m^2), with the maximum weight at the focus being 680 kg (1500 lb), of which 396 kg (860 lb) was allotted to the PCS weight.

The energy conversion subsystem selected for the SCSE PCS (Figure 1-1) was a forced-air-cooled organic Rankine-cycle (ORC) engine. Other requirements imposed on the PCS included a design which used technology that approached a 30-year life similar to conventional power plants and a net thermal-to-electric efficiency of 24 to 25%. Barber-Nichols Engineering (B-N), under contract to FACC, was selected to provide the PCS. To meet the efficiency requirements, B-N proposed a high-speed (60,000 rev/min) high-temperature (400°C, 750°F) axial-flow, full-admission impulse turbine. The turbine/alternator/pump (TAP) assembly is shown in Figure 1-2. Toluene was selected as the working fluid because of its thermal stability and high cycle efficiencies at these temperatures. Hermetic sealing of the PCS was specified to eliminate the chemical breakdown of the toluene when exposed to oxygen at temperatures above 205°C (400°F). The efficiency and hermetic sealing requirements, combined with the long-life specification, made toluene-lubricated hydrodynamic fluid film bearings the most attractive approach. Requirements to operate at altitude angles up to 90 deg made tilting-pad journal bearings desirable for maximum rotordynamic stability.

Details of the development and testing of the organic Rankine-cycle module for SCSE are contained in References 1-1 and 1-2.

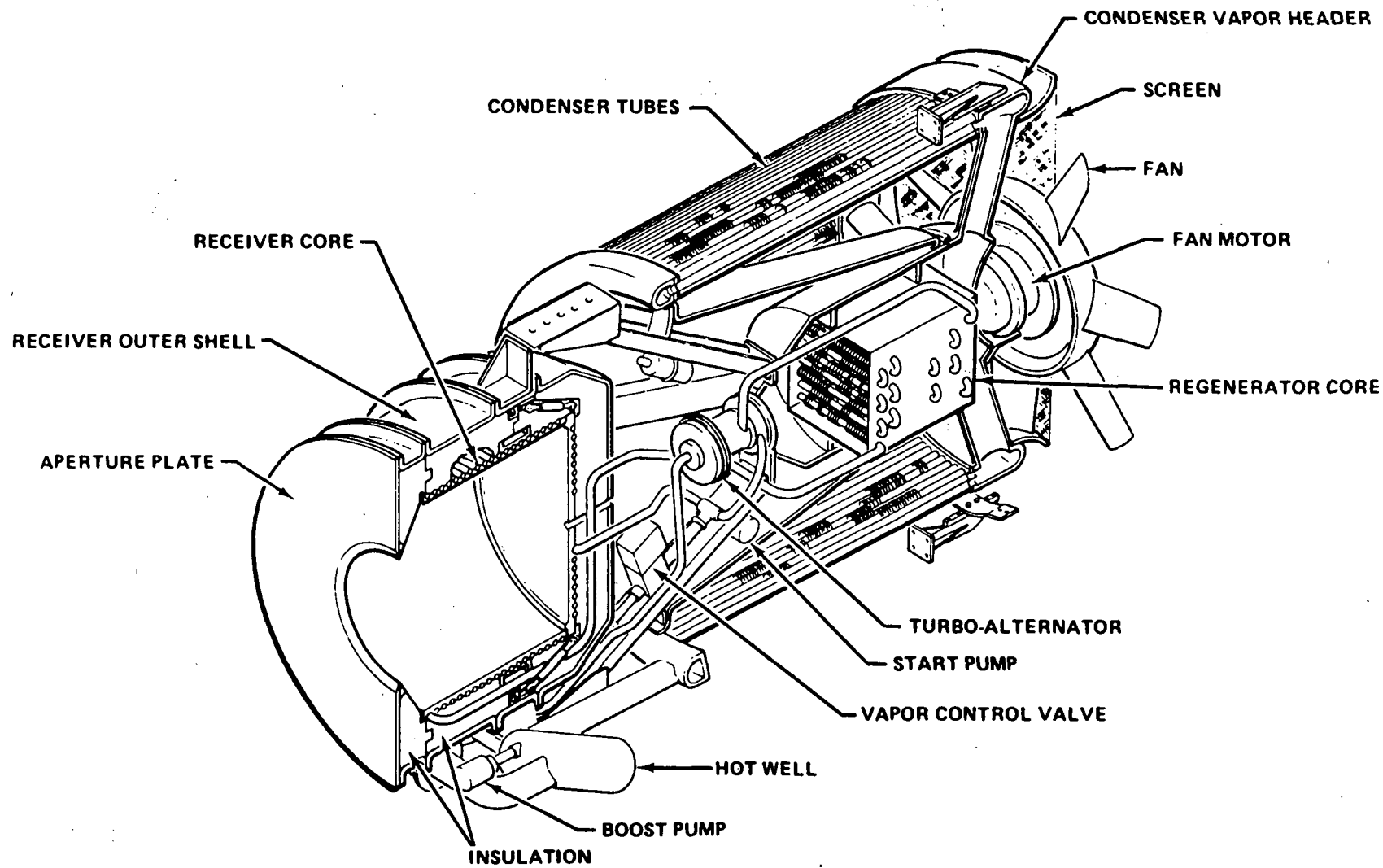

Figure 1-1. Power Conversion Subsystem

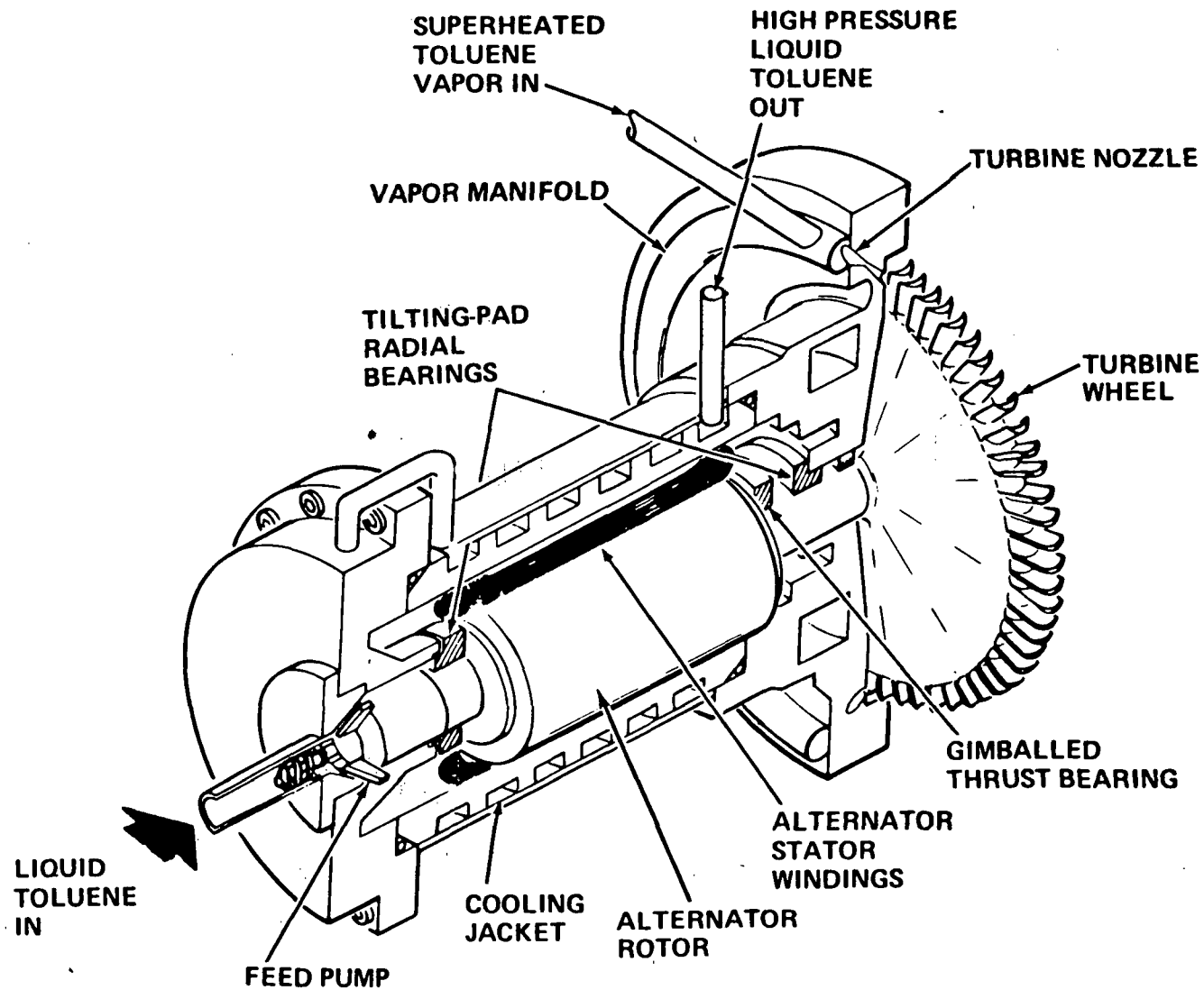

Figure 1-2. Turbine/Alternator/Pump (TAP) Assembly

SECTION II

ORIGINAL BEARING DESIGN AND DEVELOPMENT MODIFICATIONS

Barber-Nichols selected three-pad tilting-pad journal bearings (Figure 2-1) and flat-pad thermal wedge (Fogg) thrust bearings (Figure 2-2) in their original design concept. All bearings were to be self-aligning (to compensate for any build misalignment) and made of tuframe-coated aluminum. Spherical pivots on the back of each journal bearing pad provided both pivoting and self-aligning capabilities. Self alignment in the thrust bearings was accomplished with a gimballed mounting ring. B-N recommended their own previously demonstrated bearing lubrication technique (Figure 2-3) in which bearing lubricant entered an axial hole at the pump end of the shaft on the shaft center line and flowed axially down the spinning shaft to both pump end bearings. Under each pump end bearing, both radial and thrust, a single radial hole was drilled completely through the shaft to provide two holes to centrifugally deliver fluid to each bearing. Beyond the pump end radial and thrust bearings, the lubricant passed radially into a larger annular section to cool the alternator rotor then reduced back to a smaller diameter on the shaft centerline to lubricate the turbine end bearings.

Development and compatibility testing of the original bearing and lubrication design were conducted in a first-generation bearing test rig (Figure 2-4) that operated at various speeds and altitude angles and simulated the rotor mass and dimensions without a permanent magnet alternator (PMA) rotor. Several bearing materials, shaft materials, shaft coatings, and lubricants were tested, including some simple journal bearings, before bronze three-pad tilting-pad journal and bronze Fogg thrust bearings were selected to operate on a 4140 steel shaft and 304 stainless steel thrust runners. Each tilting pad was 0.380 in. wide running on a 0.625-in.-diameter shaft with ball-and-socket pivots located 65% behind the rounded leading edge. Both thrust bearings were 1.18 in. in diameter and located at opposite ends of the alternator rotor. Figure 2-5 shows the complete TAP rotor. Outboard and adjacent to each thrust bearing was a journal bearing with an overhung feed pump impeller and overhung turbine wheel at either end of the shaft. With the successful results from the first-generation bearing test rig, the decision was made to proceed with complete PCS testing.

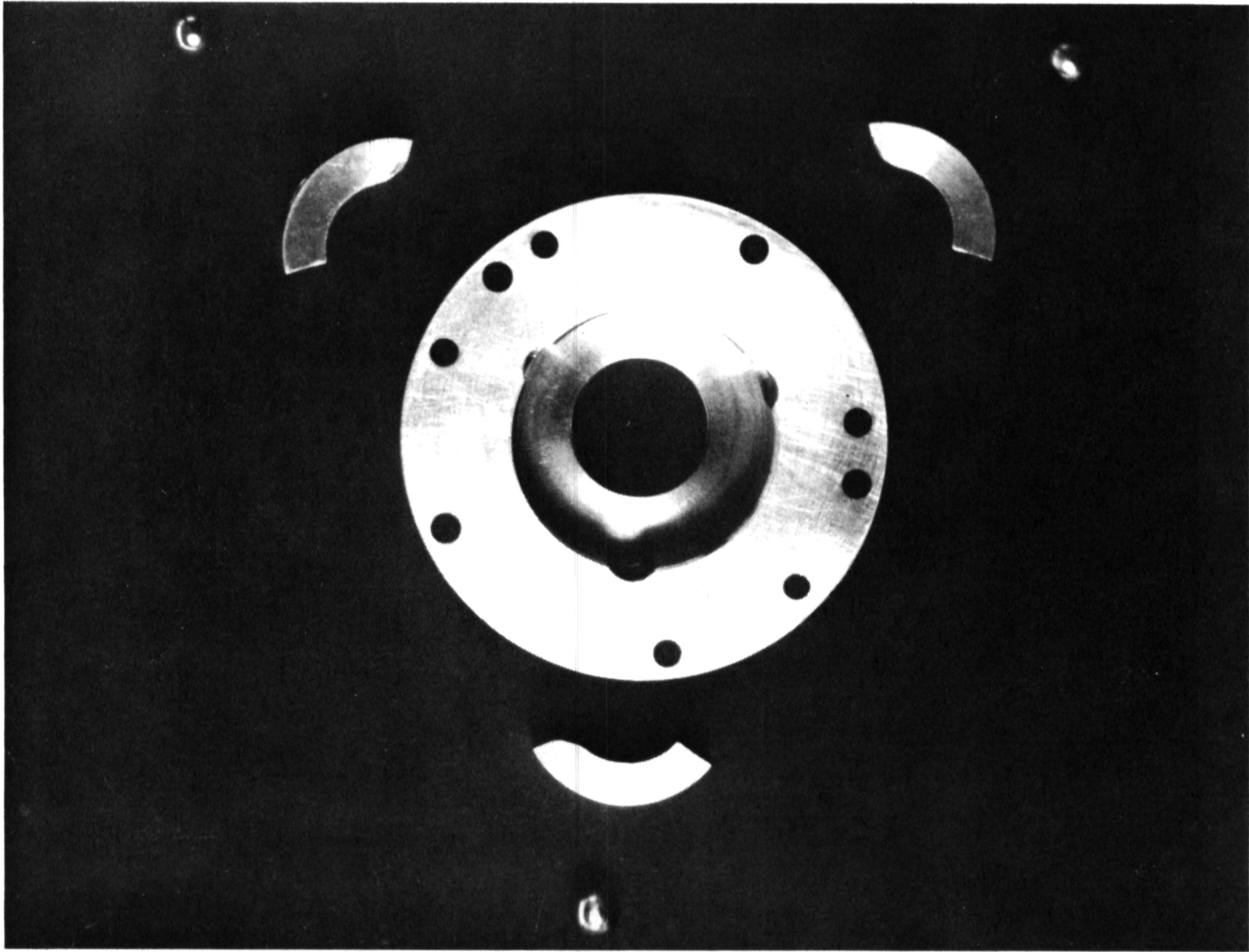

Figure 2-1. Original Design (Barber-Nichols) Three-Pad Spherical Pivot Tilting-Pad Journal Bearing

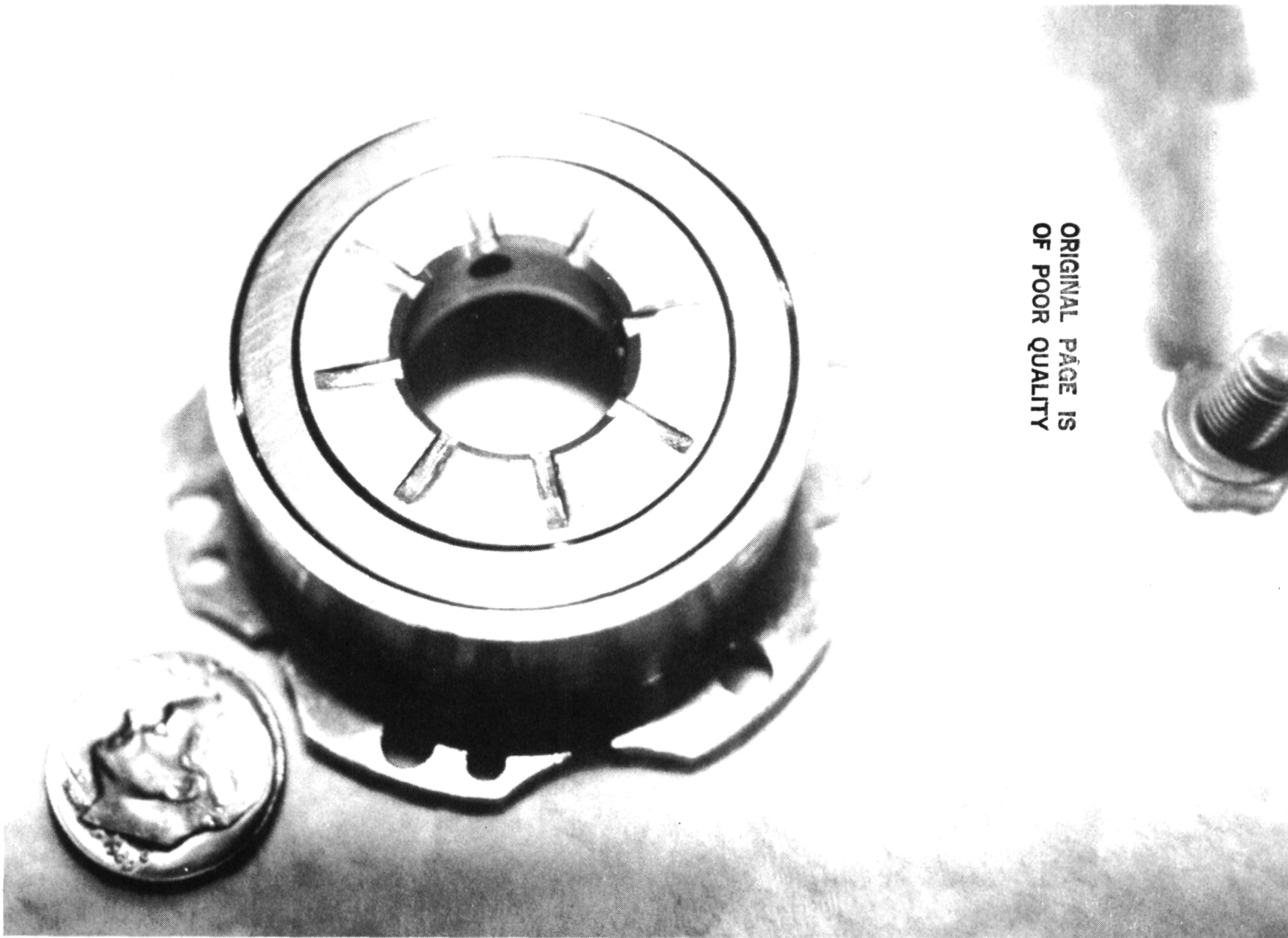

Figure 2-2. Original Design (Barber-Nichols) of a Gimbal-Mounted Flat Pad Thermal Wedge (Fogg) Thrust Bearing

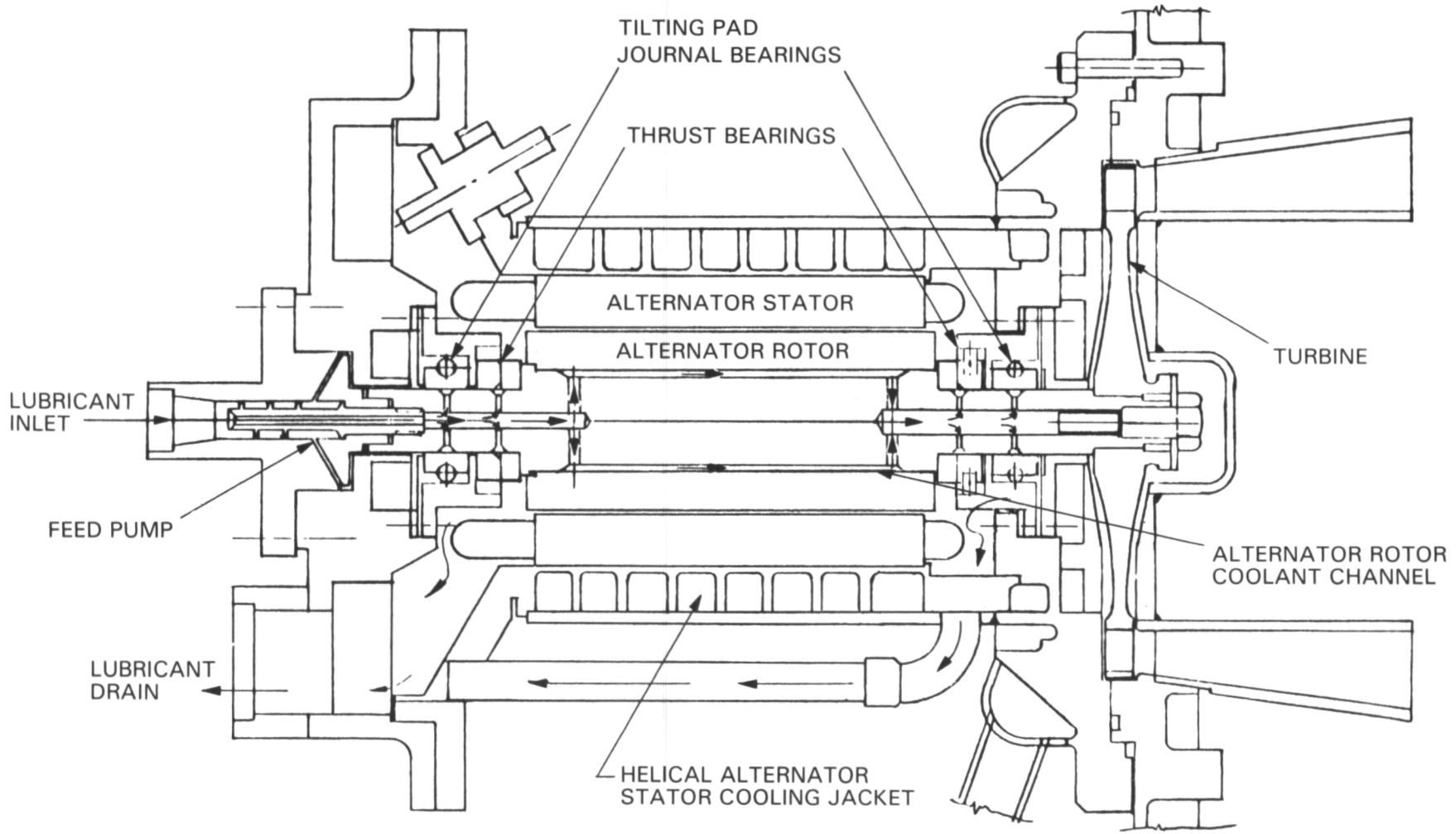

Figure 2-3. Original Bearing Lubrication Design (Barber-Nichols)

ORIGINAL PAGE IS
OF POOR QUALITY

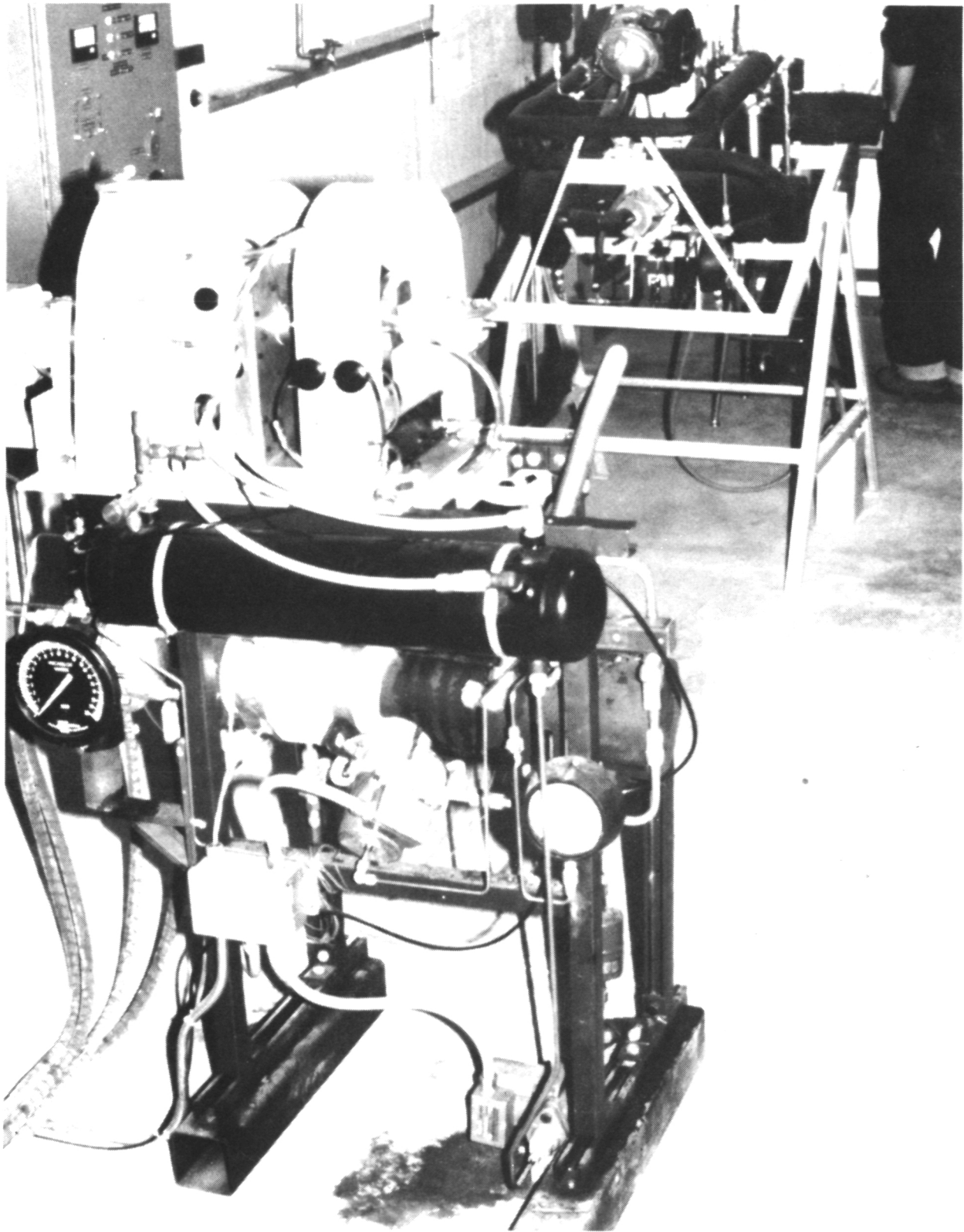

Figure 2-4. First-Generation Bearing Test Rig

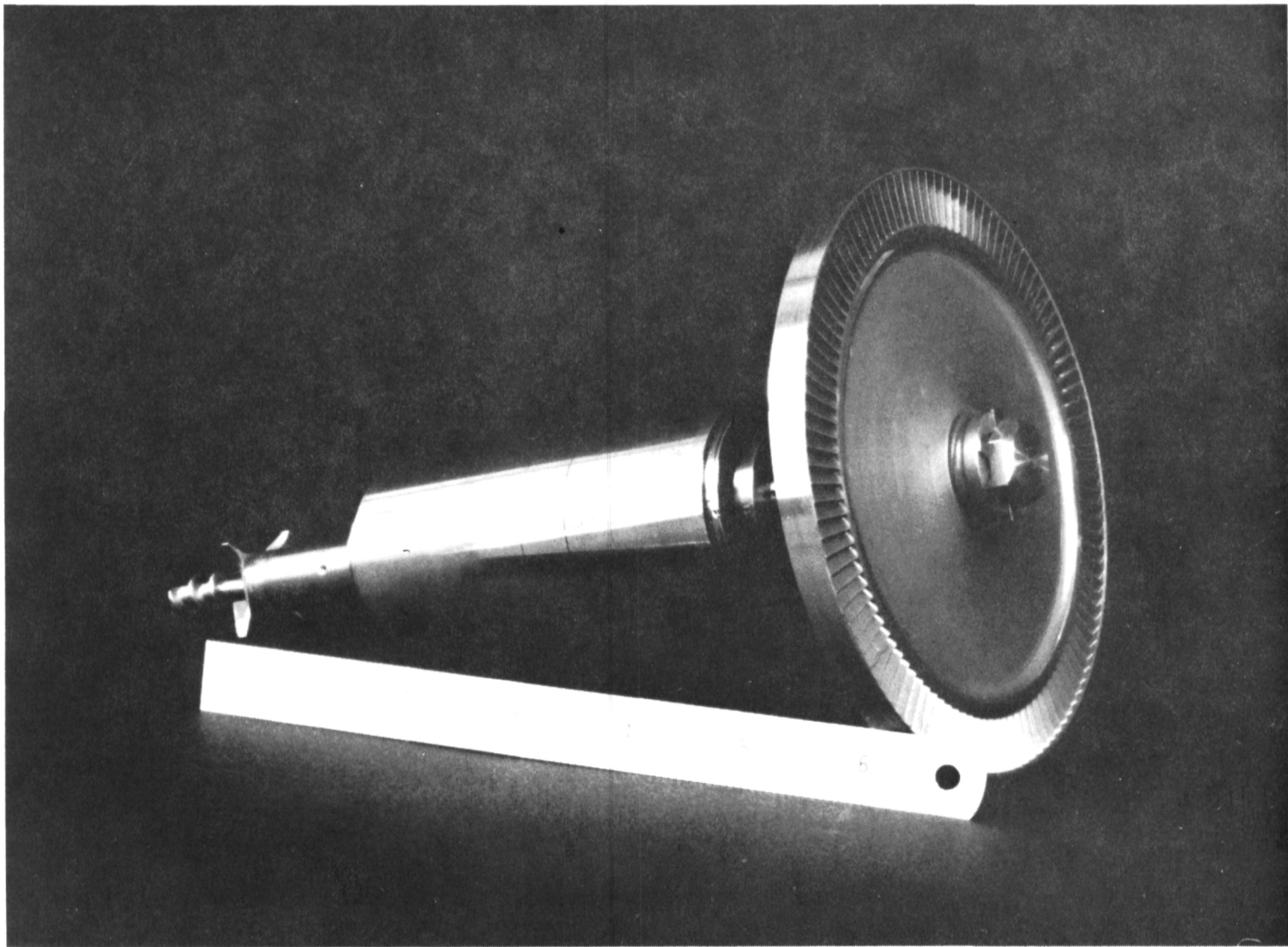

Figure 2-5. Complete TAP Rotor with Turbine, Alternator, Pump, and Thrust Runners. Note that one lubricant exit hole is visible between the pump and alternator on the shaft

SECTION III

BEARING TESTS IN THE COMPLETED POWER CONVERSION SUBSYSTEM

The bearing system described in Section II was installed in the complete PCS and tested at a 45-deg altitude angle (Figure 3-1). An electric resistance boiler was used as the engine heat source for these tests at B-N. Turbine/alternator/pump (TAP) build 1 showed severe radial bearing wear, tilting-pad pivot seat damage, minor thrust bearing wear, and a rotor imbalance problem at the conclusion of only 3.5 h of operation. Because a significant percentage of the 3.5 h was at low turbine speeds, it was suspected that the bearings were not lifting off properly or were overloaded for this speed range. Build 2 duplicated build 1, but tests were run at nominal operating speeds. Unfortunately, the results were the same with the addition of a single large pit on the turbine end thrust bearing at the conclusion of 3 h of operation. It was suspected that this pit was either a single material imperfection or the result of electrostatic discharge.

A number of modifications were incorporated into TAP build 3. A grounding strap was attached to the shaft to eliminate the possibility of electrostatic discharge across the bearings to the grounded engine. Helical screw pump-out seals were added to the alternator rotor to eliminate the possibility of liquid hold-up between the PMA rotor and stator and thus to improve the relatively low observed engine efficiency. Each tilting pad was reduced in mass by making linear angular cuts on the backside of the pads from the pivot point socket to the leading and trailing edges, and the rounded leading edge of each pad was replaced with a 10-deg chamfer (Figure 3-2). The lower mass pads would be less susceptible to dynamic problems, and the small chamfer would increase the effective bearing area and provide a more uniform leading edge. Side clearances on each pad were reduced to correct observed edge wear (Figure 3-3), which resembled patterns expected with excessive yaw of the pad. Each pivot ball was spring-loaded to ensure proper orientation during engine start-up.

Severe pump end radial and varying amounts of turbine end thrust and radial bearing wear was observed as well as the imbalance in the rotor at the conclusion of each run through TAP build 5. Many tests, including bake-out of the alternator rotor, were conducted to explain why the rotor was balanced before each test and out of balance after each test. Modifications to TAP build 4 included a turbine end dynamic slinger ring to prevent the possibility of liquid toluene entering the turbine housing along the shaft and to improve the low PCS efficiency. The shaft diameter was reground from 0.625 to 0.615 in. to clean the surface, and an original radial bearing set was installed to reduce downtime and to continue performance mapping in TAP build 5. TAP build 6 incorporated the more recent low-mass pad concept with a new 0.560-in.-wide tilting pad design made of 52100 steel with a tin-antimony flame-sprayed babbitt coating. The wider pad design increased the load-carrying capability of the bearing by increasing effective load-carrying area. Selecting 52100 steel increased the load capacity of the ball-and-socket pad pivot that seemed to be displaying some type of surface-loading distress on the bronze pads.



Figure 3-1. Power Conversion Subsystem Test at Barber-Nichols Using (a) an Electrical Resistance Toluene Vapor Generator

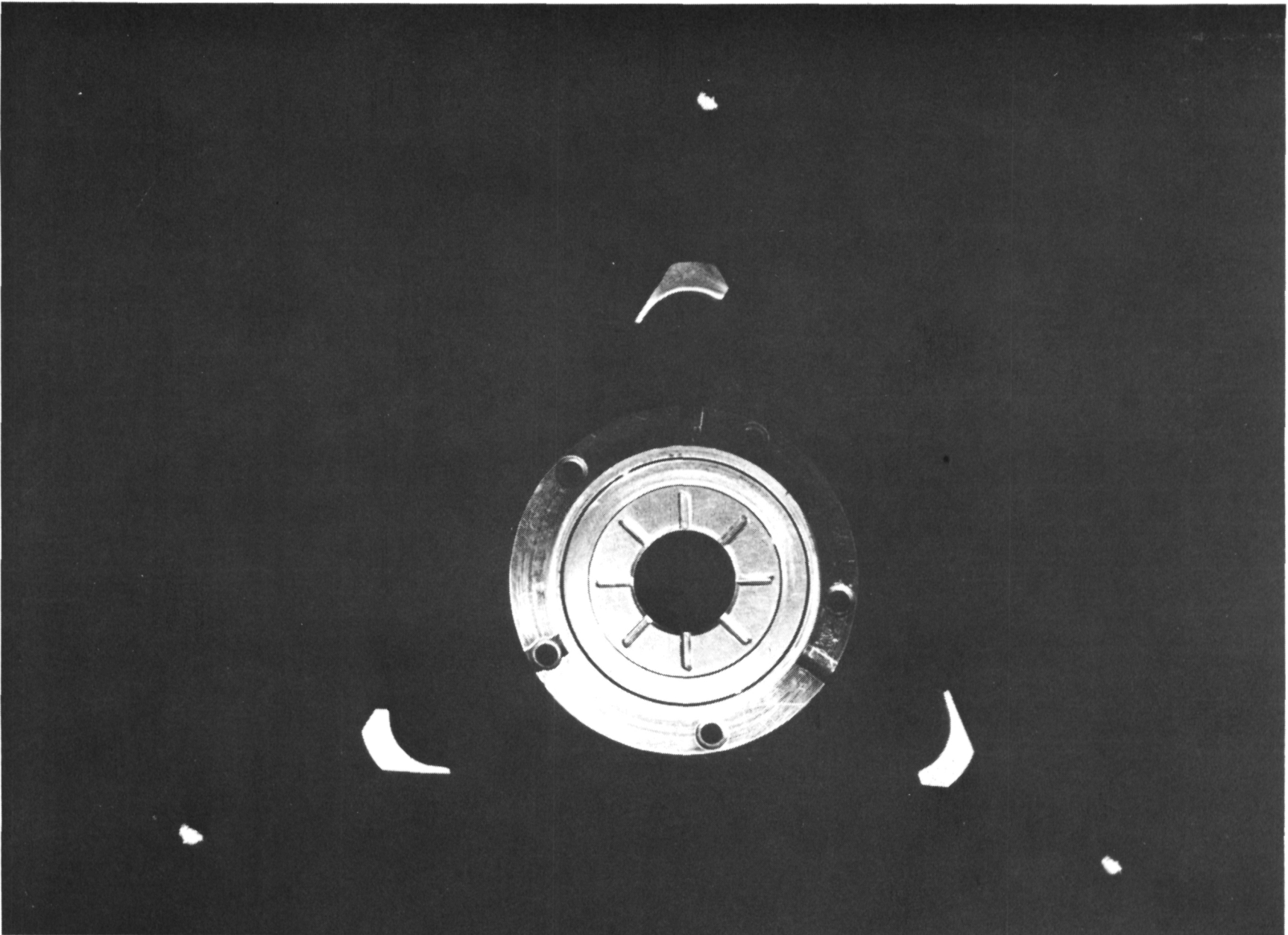

Figure 3-2. Reduced-Mass Tilting Pads with 10-deg Leading Edge Chamfer

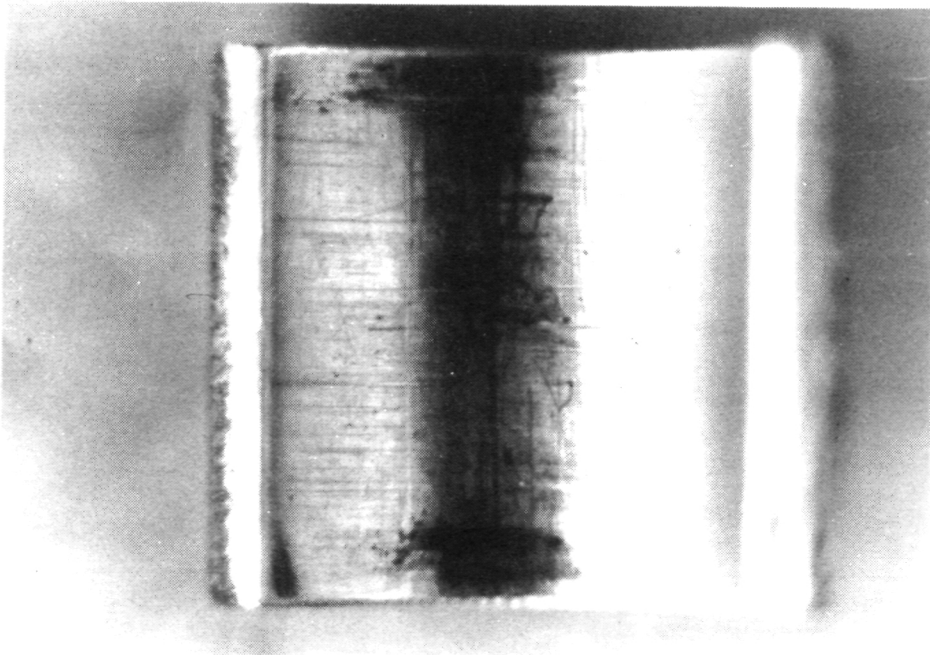
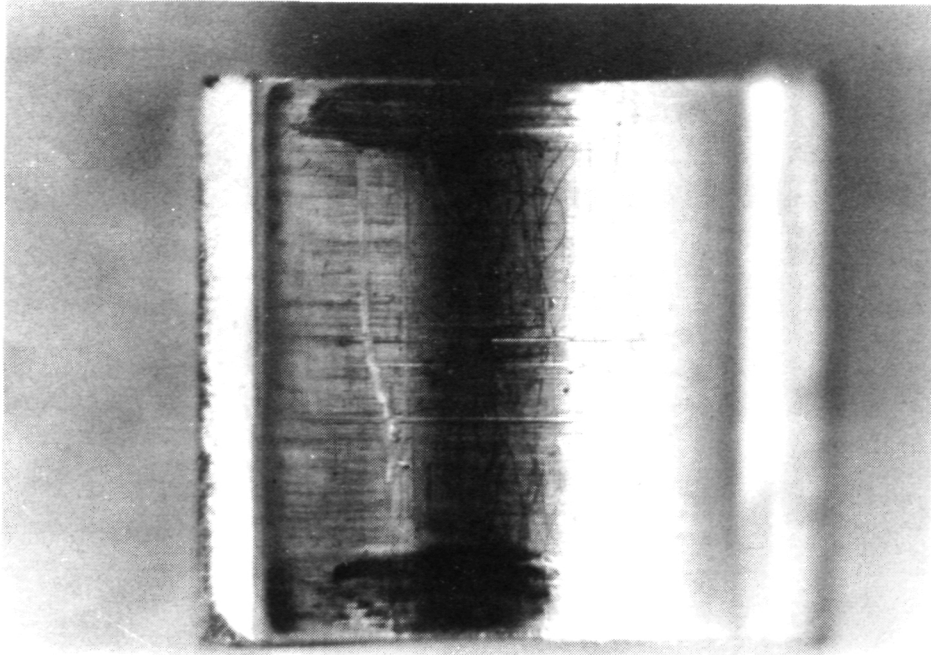

Figure 3-3. Edge Wear on Tilting Pads, Possibly Caused by Excessive Yaw Motion

Tin-antimony babbitt provided a more forgiving metal-to-metal contact surface than bronze for initial start-up and lift-off of the pads. The two most severe wear patterns on the turbine end thrust bearing coincided with the two gimbal pin locations on the bearing. This raised a suspicion that the thrust bearing was deflected under load at all locations except where supported by the gimbal pins. The locations of the thrust bearing gimbal pins were changed so that they would not coincide with the lubrication grooves in each thrust bearing. Because there was no measurable improvement in PCS performance in builds 4 or 5, the slinger ring was removed. Immediately upon reaching design speed for the first run of TAP build 6, the turbine wheel rubbed the turbine housing because of plastic deformation of the wheel at high speed. Apparently at high operating speeds the wheel plastically deformed and redistributed the mass of the wheel, thus continuously changing the rotor balance. The excessive imbalance caused severe bearing loads that resulted in pounded and worn journal bearings. Barber-Nichols followed the Inconel 718 supplier's recommendations by heat treating and brazing the turbine wheel and shroud in two separate consecutive processes; unfortunately, this technique resulted in excessive grain growth and an overall reduction in material strength. The process was corrected by simultaneously heat treating and brazing in a single process to minimize grain growth and increase material strength.

Although all of the bearing design modifications incorporated between TAP builds 1 through 6 tended to improve the bearing design and increase the load-carrying capability of the bearings, it was decided to confirm the capabilities of the existing bearing design in the first-generation bearing test rig. These bearings successfully completed 8 h of test in the bearing test rig and were installed in the complete PCS with a new properly brazed and heat-treated turbine wheel. Accelerometers were installed on the TAP housing in an attempt to monitor vibration resulting from rotordynamic instability.

Inspection of TAP build 7 after 11.6 h of test revealed minimal wear on the journal bearings and severe wear on the turbine end thrust bearing that resulted in wear on the back side of the pump impeller because of significant axial displacement. During normal operation, the net axial force on the rotor tended to load the turbine end thrust bearing regardless of TAP orientation. The pump end thrust bearing was only loaded briefly during engine start-up and shutdown and therefore was never damaged.

All accelerometer measurements were extremely high and fluctuating both in frequency and amplitude, making conclusive results impossible. In TAP build 8 the turbine end thrust bearing was redesigned to increase the diameter from 1.19 to 1.5 in., and the bearing material was changed from bronze to flame-sprayed babbitt on 52100 steel (Figure 3-4). The thrust runner diameter was also increased, and the material was changed from 304 stainless to 17-4 PH steel. A silver flash coating was applied over the babbitt on the journal bearing pads in an effort to further minimize start-up and shutdown contact wear.

TAP build 8 was unsuccessful because the silver coating on the journal bearings separated from the babbitt and redeposited on the trailing edge of each pad. The journal bearings were returned to their previous design of flame-sprayed babbitt on steel without a silver coating in TAP build 9 and tested. TAP build 9 operated for 28 h at B-N with minimal noise and vibration observed.

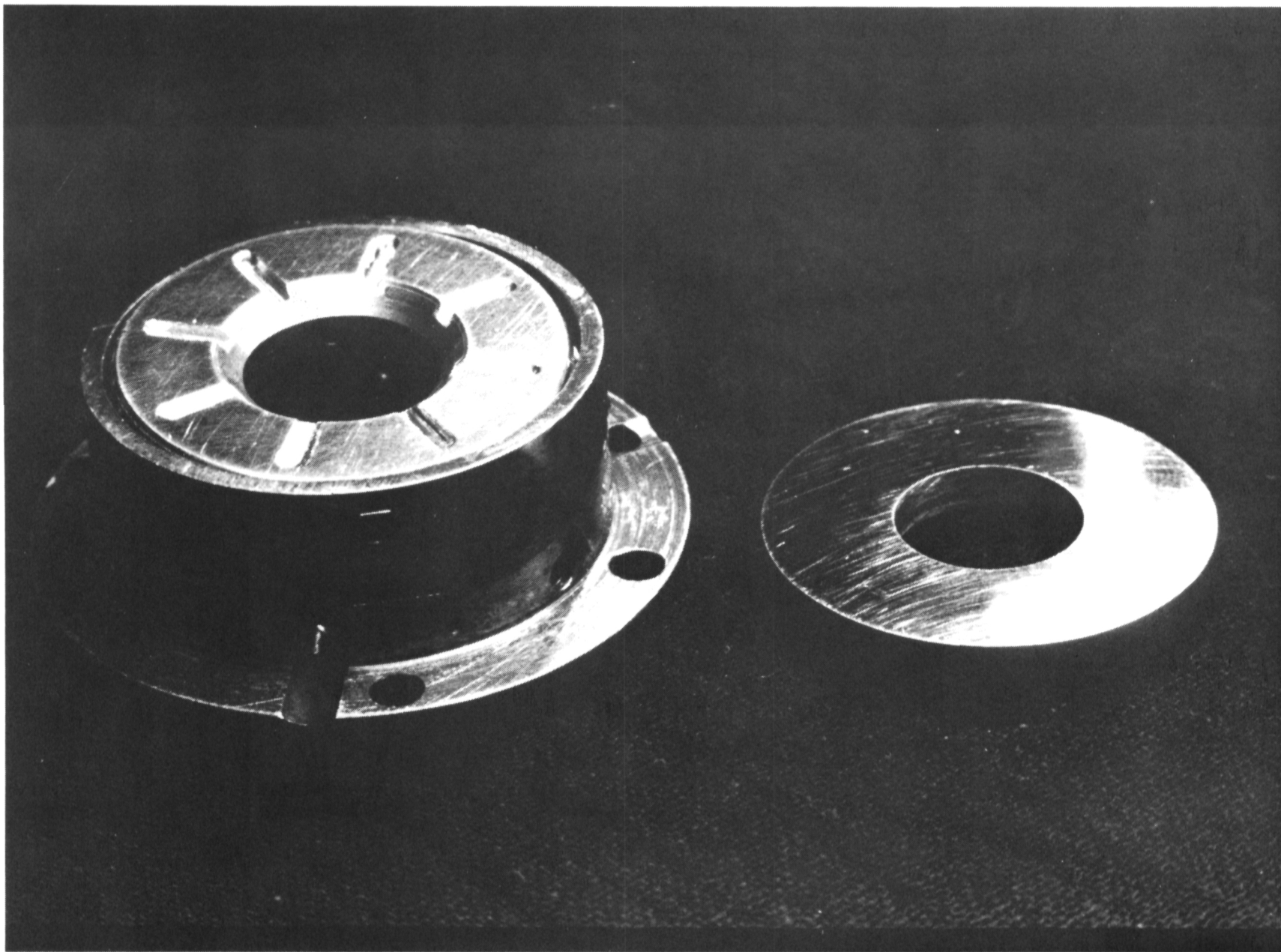

Figure 3-4. Thermal Wedge (Fogg) Turbine End Thrust Bearing (left) made of 52100 Steel with Flame-Sprayed Babbitt Surface and Thrust Runner (1.5-in. diameter) made of 17-4 PH Steel

A major decision had to be made to either continue development testing at B-N to obtain additional confidence in the design or to ship the PCS to FACC for testing with the receiver and inverter. FACC personnel had completed the test setup and were prepared to mate the engine, receiver, and inverter. The electric resistance heater used in previous receiver tests was already in the test cell as was the computer control system, data acquisition system, and resistive load bank for the inverter output. The desire to complete checkout tests of these components as soon as possible in a complete system became the principal criterion. Any problems discovered in other subsystems would need immediate attention to support the even more important follow-on tests on-sun, delivering power to the utility grid at the Parabolic Dish Test Site (PDTS). It was decided that any additional modifications to the PCS could be incorporated on-site or by returning the TAP to B-N. With all of these considerations in mind, the decision was made to ship the PCS to FACC for testing.

SECTION IV

POWER CONVERSION ASSEMBLY AND INVERTER TESTS

The PCS and receiver were mated together¹ and installed in a test cell at FACC (Newport Beach, California). Heat was delivered to the receiver cavity using a 112-kWe resistance heater with silicon carbide heating elements (Figure 4-1). Electrical output from the PCS rectifier was delivered to the inverter, which then dissipated the power in a resistive load bank. Figure 4-2 shows the PCA in the FACC test cell.

Toluene samples from the PCS revealed traces of mineral oil and dioctylphthalate contaminants. After any repair that required breaking the hermetic seal, a vacuum pump was used to remove air, thus minimizing condenser pressure, condenser temperature, and toluene degradation. It was suspected at this time that the PCA vacuum had drawn some vacuum pump oil into the system because of improper valve sequencing. New procedures were written and implemented for evacuating the system of non-condensibles and preventing accidental transfer of vacuum pump oil into the PCA.

TAP build 9 operated for 25 and 28 h at FACC and B-N, respectively. Excessive noise from the TAP prompted the decision to disassemble and inspect. Severe damage to the TAP turbine end thrust bearing was discovered. The turbine end thrust bearing and thrust runner were so severely worn that axial displacement of the shaft resulted in the back surface of the feed pump impeller being worn away against the TAP housing. The turbine wheel hub and shroud suffered only minor wear as a result of significant axial movement and contacting of adjacent housing surfaces. It was speculated that insufficient lubrication to the pump end radial and turbine end thrust bearing caused the failure because these two bearings were the most severely worn.

A number of TAP and PCS modifications were incorporated into build 10 in an attempt to correct the bearing wear problem. Four radial lubrication holes were added at the turbine end thrust bearing and two were added at the pump end radial bearing for TAP build 10. An additional boost pump was added to the system in series with the original boost pump to double the inlet pressure to the feed pump and lubricant flow path entrance. This higher pressure would tend to eliminate any possibility of feed pump cavitation and increase the lubricant flowrate to all bearings. The turbine wheel, feed pump impeller, and turbine end thrust bearing were replaced with identical components; however, the turbine end thrust runner was fabricated from 4140 instead of 17-4 PH steel. TAP build 10 operated for 4.8 h before a decision was made to disassemble and inspect the hardware. This decision was prompted by the very low-level random noises heard propagating from inside the TAP and the desire to observe the failure mechanism from inception rather than after major damage had occurred. Inspection of TAP build 10 revealed severe wear on the turbine end thrust bearing and minor thrust runner wear. Contact occurred between the back of the pump impeller and TAP housing. At the conclusion of this test,

¹The ORC engine and PMA plus receiver is called the power conversion assembly (PCA).

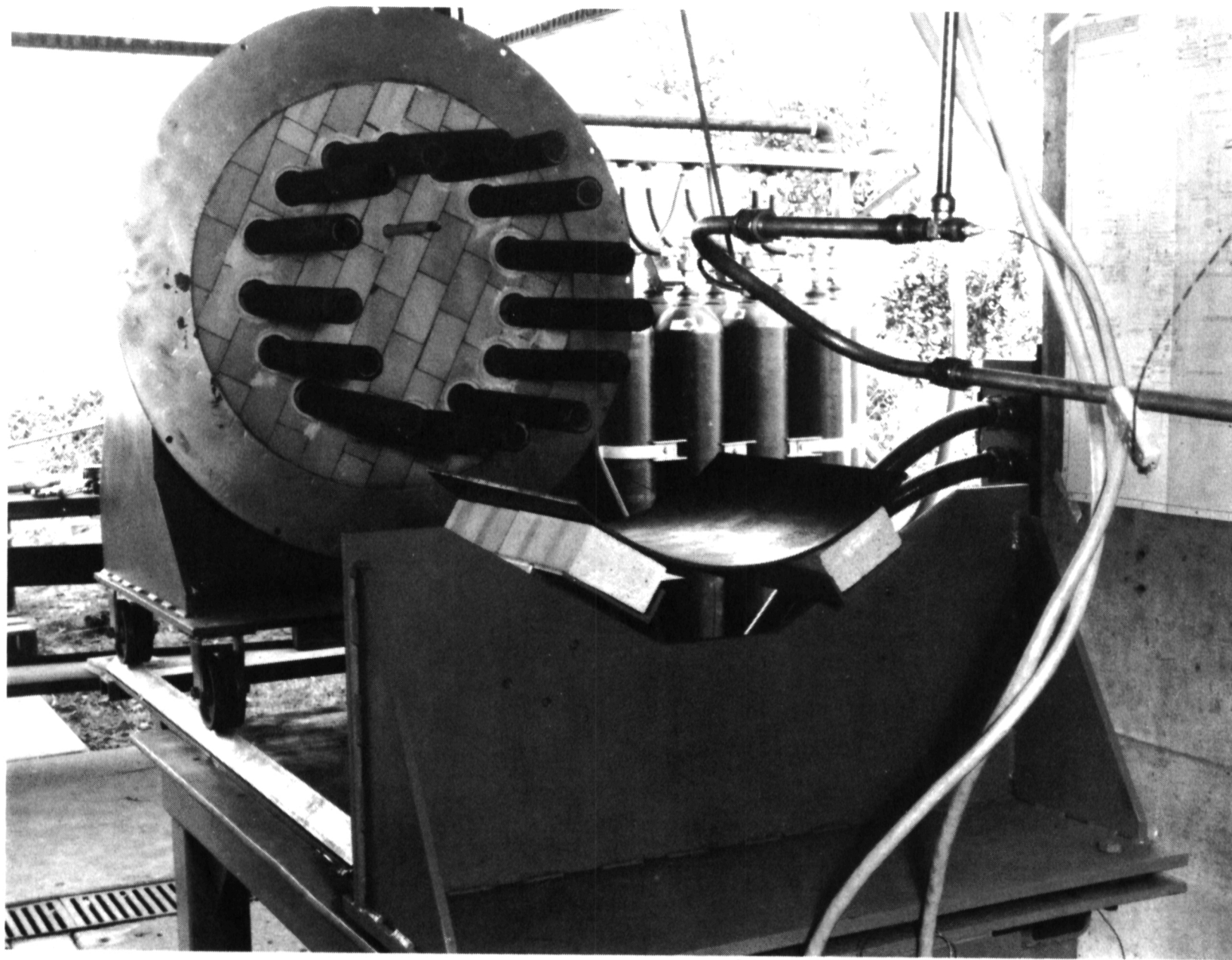

ORIGINAL PAGE IS
OF POOR QUALITY

Figure 4-1. Electric Resistance Receiver Heater Used at Ford Aerospace and Communications Corporation

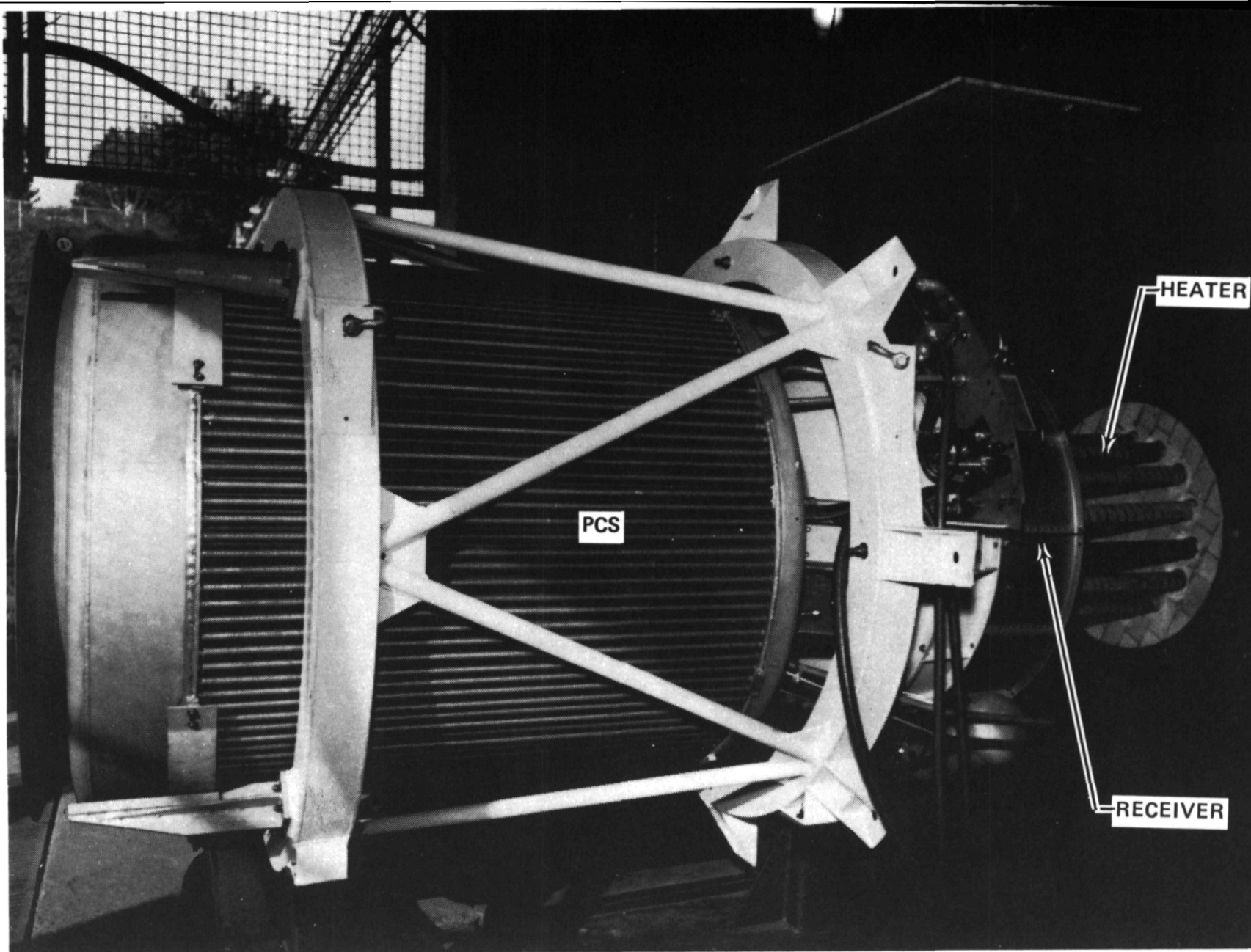

Figure 4-2. Power Conversion Assembly On-Test at Ford Aerospace and Communications Corporation (Source: SCSE Test Report, PCS/Receiver Compatibility Tests at Ford Aerospace, Contract 955637, CDRL Item No. 34, FACC, April 16, 1982)

proper quantities and distribution of lubrication to the bearings and TAP assembly quality control were the primary concerns. Assembly quality control was suspect because the original built-in clearances could not be reconciled with the quantity of wear on the pump impeller.

Proper functional operation of the receiver, control system, PCS, inverter, and load bank were demonstrated at this time in the FACC test bay. It was decided that with the exception of the PCS bearings, the system was ready to be tested on a solar test bed concentrator delivering power to the load bank or electric utility grid. The consensus was that modifications to and development of the bearings could be incorporated with the solar concentrator and utility interface demonstration tests. Design modifications were made in TAP build 11, and all hardware was shipped to the JPL Parabolic Dish Test Site at Edwards AFB, California.

SECTION V

ON-SUN POWER CONVERSION ASSEMBLY AND UTILITY INTERFACE SYSTEM TESTS AT THE PARABOLIC DISH TEST SITE

TAP build 11 used for the PDTs tests included modifications to the bearing lubrication system, the feed-pump inducer, and a general emphasis on quality control. Modifications to the lubrication system required the fabrication of a shaft with two radial lubrication holes at the pump end thrust bearing and four radial holes at all other bearings. The chamfer at the inside diameter of the turbine end thrust bearing was enlarged to function as a reservoir to provide additional immediately available lubrication to the bearing. The turbine end thrust bearing surface was improved to a 6-microinch finish. The shaft lubricant channel was made into a single straight-through shaft centerline hole (Figure 5-1) by boring through the shaft from the turbine end until the hole connected with the pump end center line channel. Both PMA rotor cooling holes were plugged except for a sacrificial bleed into the larger diameter annulus to cool the rotor (Figure 5-2). A small jet pump was installed at the shaft lubricant inlet that extracts fluid from the feed pump to increase the total lubricant flow to the bearings. The feed pump housing (Figure 5-3) shows the jet pump nozzle in the center and the off-center extraction port. The feed pump inducer was changed from a single to a double helix with a smooth entrance to increase load and flow symmetry (Figure 5-4).

A total of 33.6 h of operation on a PDTs test bed concentrator (Figure 5-5) was completed on-sun in all operating conditions, both normal and emergency, without any major problems (Reference 2). Toluene samples taken during these tests indicated that mineral oil and dioctylphthalate were present. It was suspected that the mineral oil came from the vacuum pump used to evacuate the system after breaking the hermetic seal for repairs. A cold trap was added to the vacuum pump to prevent vacuum pump oil diffusion into the system. Subsequent to these tests, it was suspected that the source of the dioctylphthalate was from the viton bladders in the accumulators, which use dioctylphthalate as a plasticizer. The bladder accumulators were eventually replaced with piston-type accumulators, thus significantly reducing the amount of viton exposed to toluene. Total engine and generator efficiencies of 21 to 23% were demonstrated as well as well-controlled, stable system operation. Accelerometer readings were low amplitude, well-defined single frequency values that were exact multiples of the synchronous frequency. There was no evidence of subsynchronous frequency vibrations. There were no disconcerting noises heard, only the normal high-frequency whine of the turbine. Power was delivered to the utility grid for 0.5 h before a grid transient occurred and an error in the inverter logic design caused an inverter failure. Because of the extended delivery on inverter parts, the TAP was removed and disassembled for a routine inspection. There was no reason to suspect that the bearings would be damaged prior to inspection.

Inspection of TAP build 11 revealed severe electrical arcing between the PMA stator end turns and the outside diameter of the turbine end thrust bearing (Figure 5-6). The arcing was severe enough to melt and remove a section of the turbine end bearing carrier. The outer diameter surface of the thrust bearing was severely worn, and deep pits were observed in the center of

the radial bearing pads. The back of the feed pump impeller had rubbed against the TAP housing. Subsequent analysis of PCS performance indicated a substantially lower power output of the TAP compared to the predicted output at all thermal input levels.

A number of concurrent tasks were initiated to resolve the problems discovered in TAP build 11. A Rayleigh step thrust bearing was designed and installed on the turbine end for all future builds to replace the relatively lower load-carrying flat pad (Fogg) bearing currently used. A second-generation bearing test stand was fabricated to verify the maximum load-carrying capacity of both radial and thrust bearing designs with internal shaft-fed lubrication and with external flooded lubrication. The failed PMA stator was rewound with upgraded insulation wire, potted with insulating material, and finally encapsulated in an additional toluene-resistant black stycast 2850 material (Figure 5-7). The unused spare PMA stator was only encapsulated in stycast material for future use. A TAP test stand was developed that could measure the applied torque on the tap, which in turn could be used to derive the efficiency of each tap component as it is added or removed to determine the cause of the lower-than-predicted performance. The feed pump was to be performance-tested with various back clearances to determine the effect of increased clearance on pump efficiency. It was hoped that the larger feed pump impeller back clearance would reduce the probability of contacting the TAP housing without significantly reducing the pump efficiency.

5-3

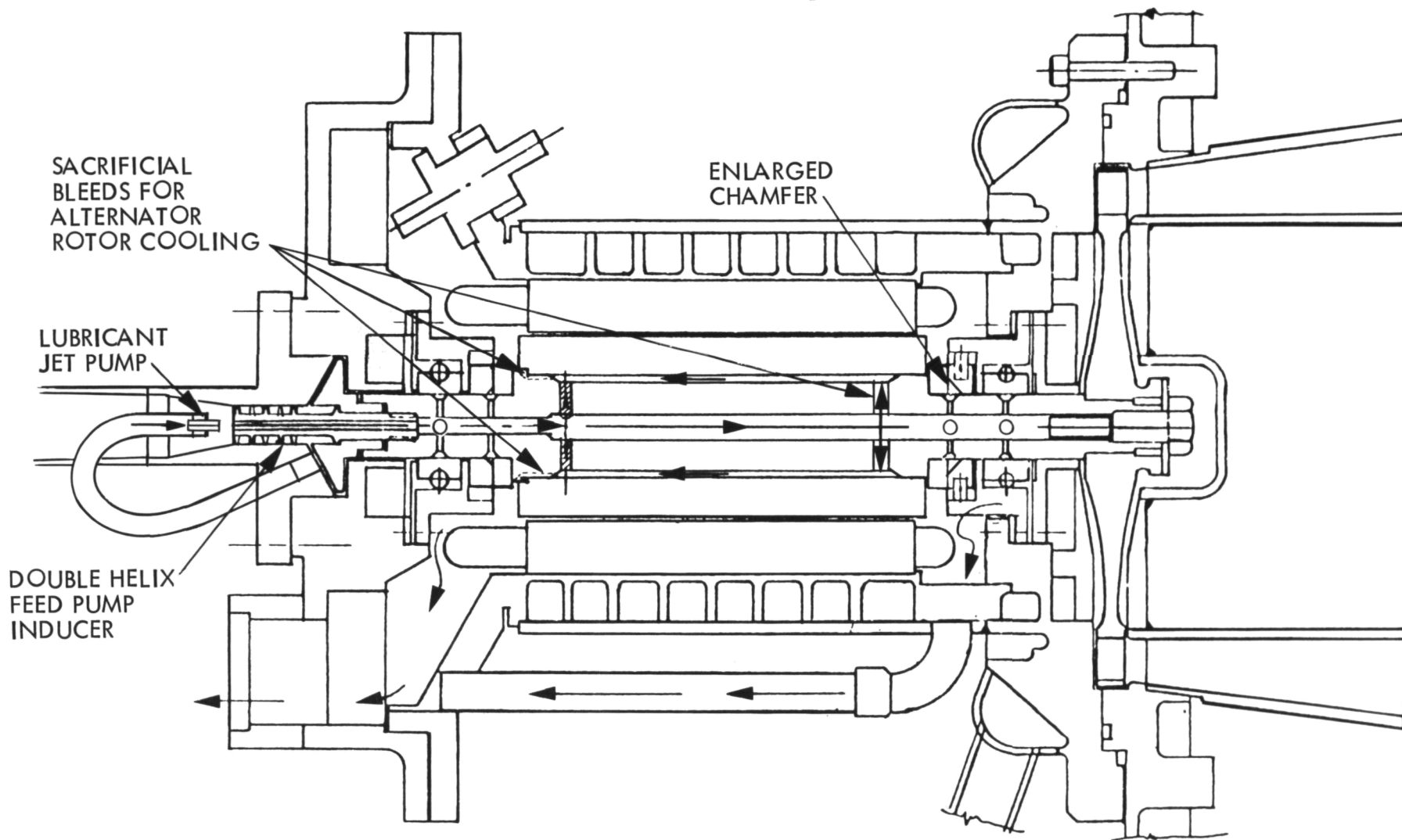
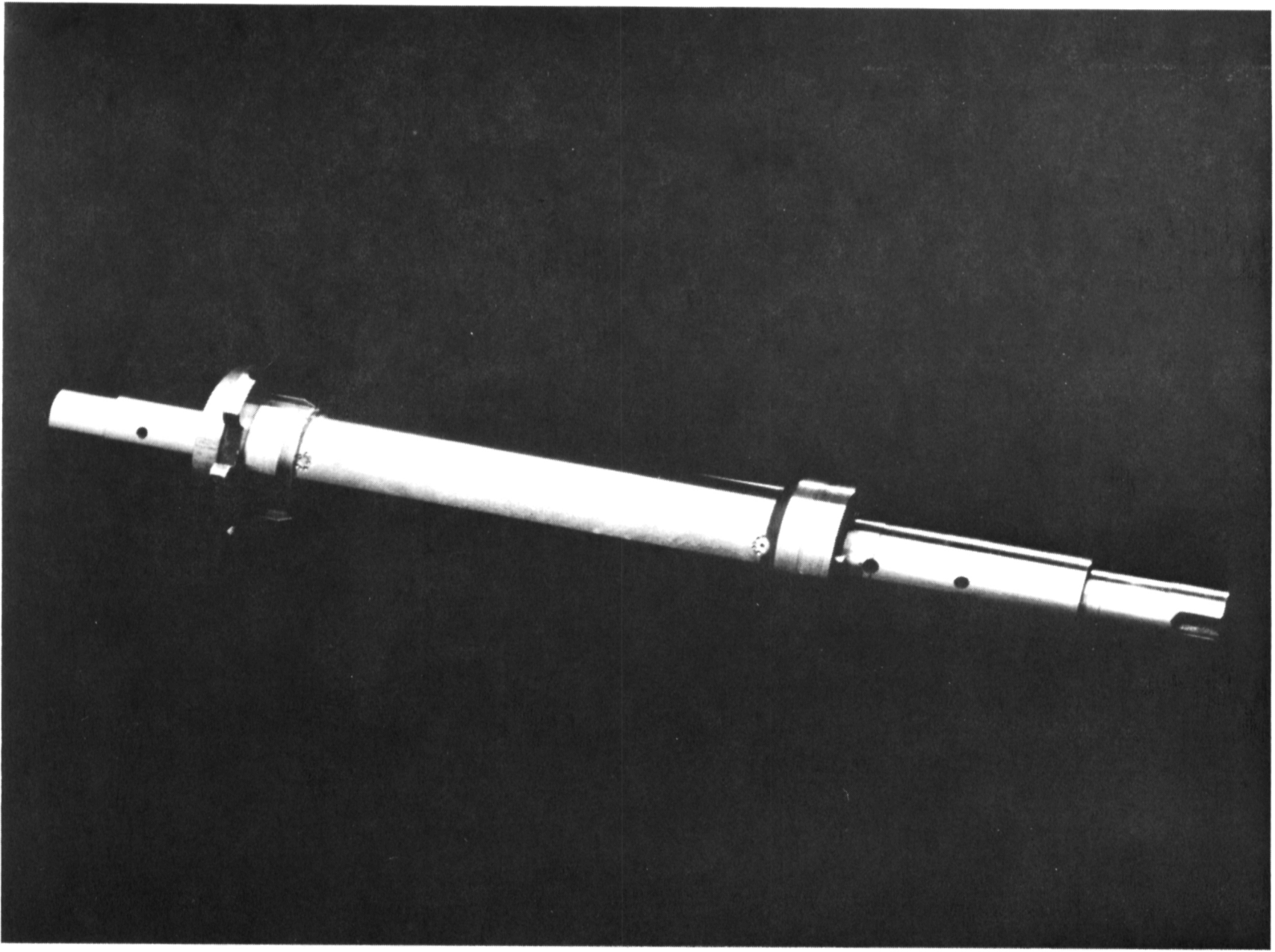

Figure 5-1. Shaft with Straight-Through Center Line Lubrication Channel (TAP Build 11)

ORIGINAL PAGE IS
OF POOR QUALITY



5-4

Figure 5-2. Shaft Showing both Rotor Coolant Holes Plugged and a Single Bleed Hole in One Plug

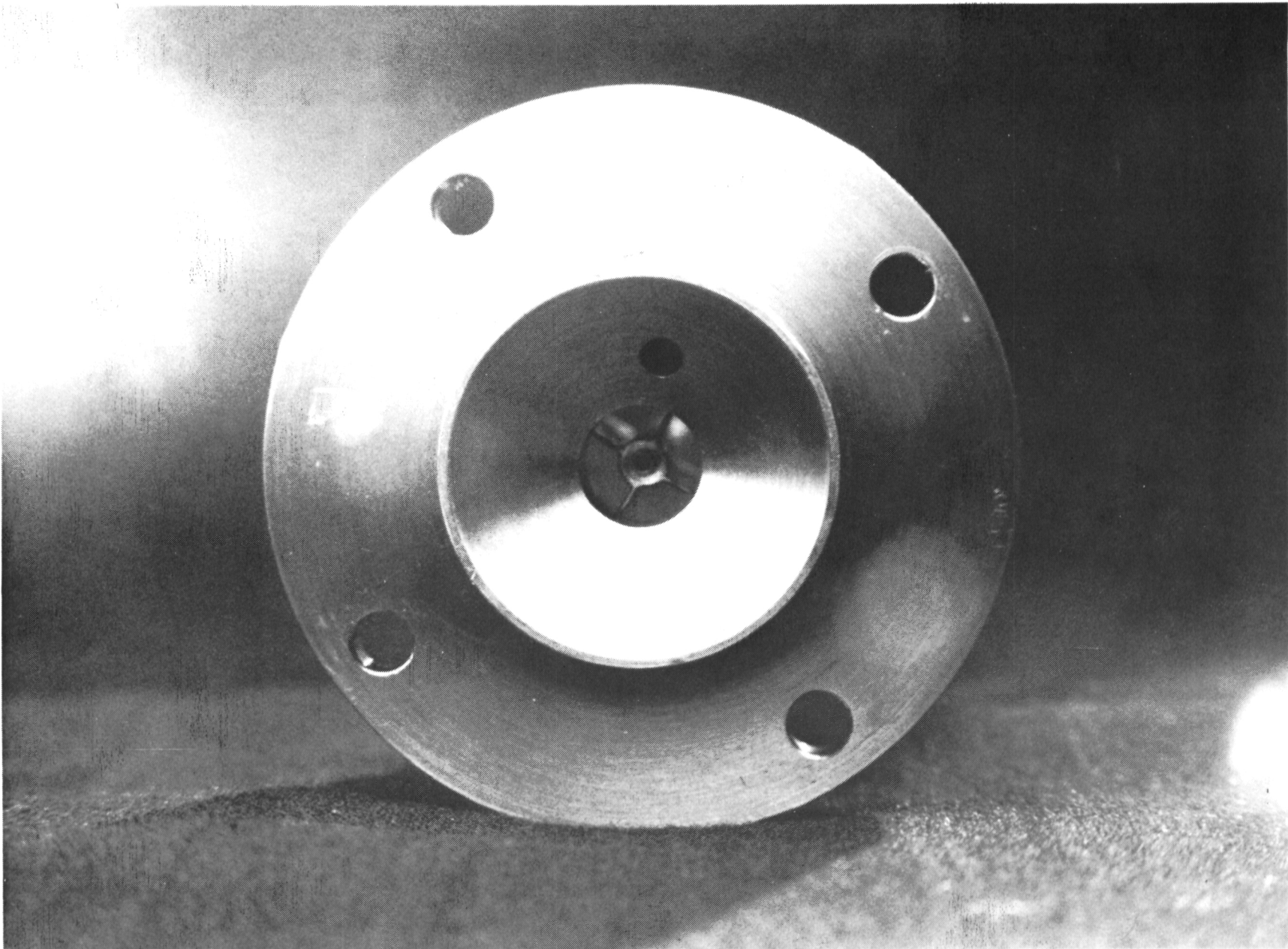

ORIGINAL PAGE IS
OF POOR QUALITY

Figure 5-3. Feed Pump Housing with Jet Pump Nozzle and Extraction Port

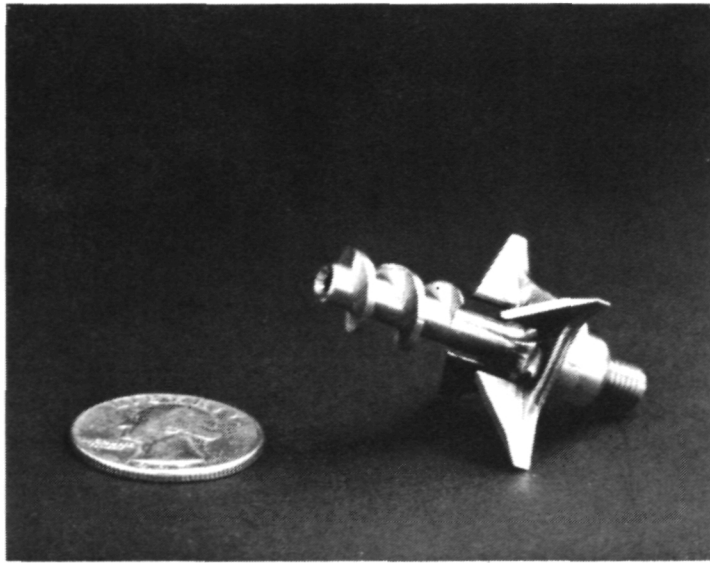

(a)

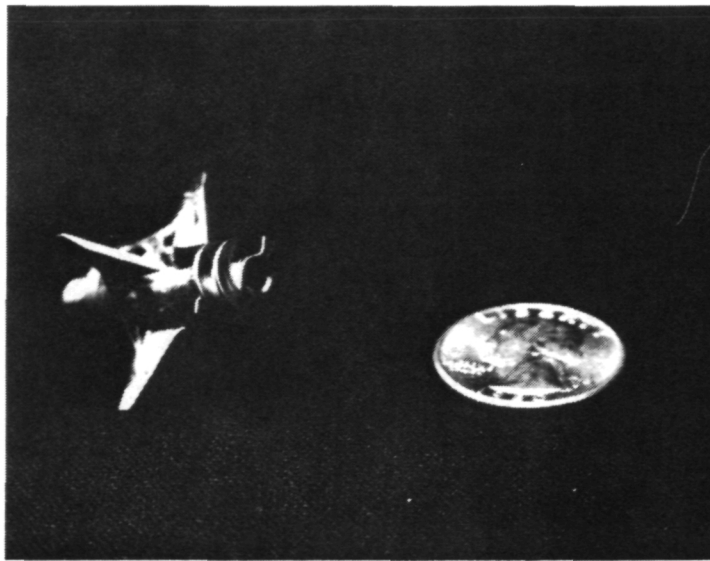

(b)

Figure 5-4. Single Helix (a) and Double Helix (b) Feed Pump Inducer

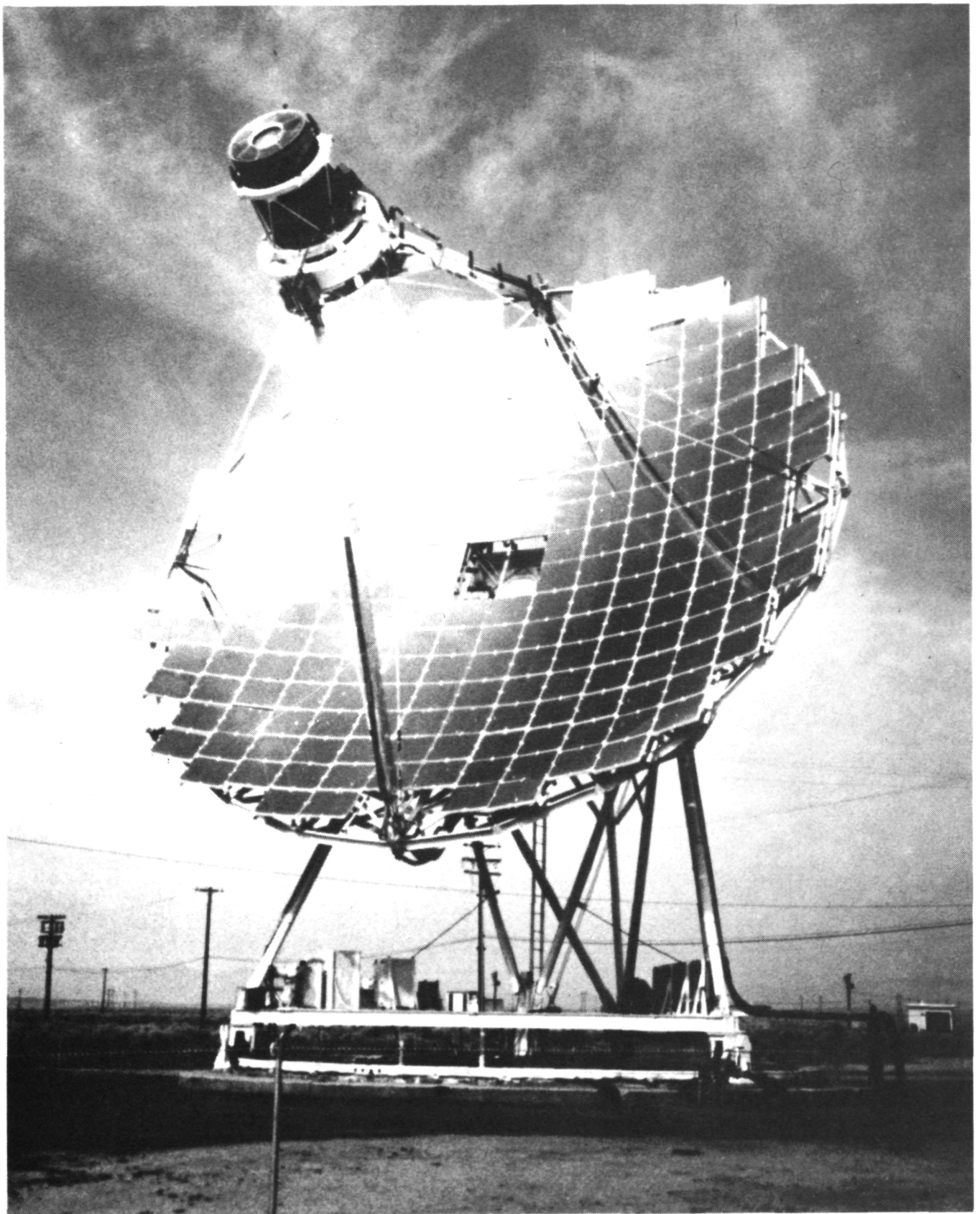
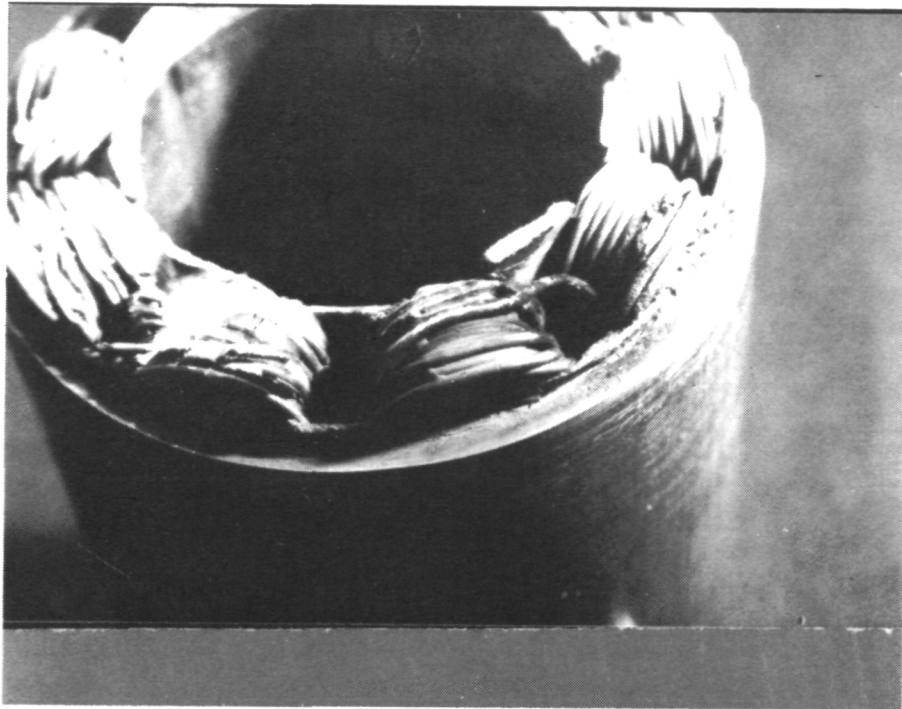
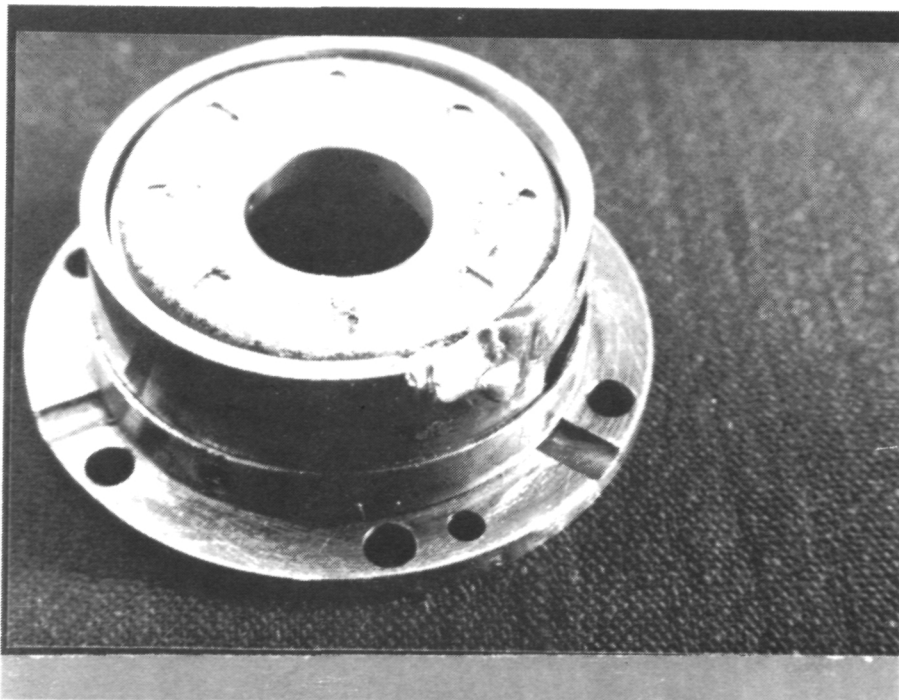

Figure 5-5. Power Conversion Assembly On-Sun Test at Edwards AFB, California



(a)



(b)

Figure 5-6. Electrical Arcing Damage between (a) the PMA End Turns and (b) the Turbine End Thrust Bearing Carrier

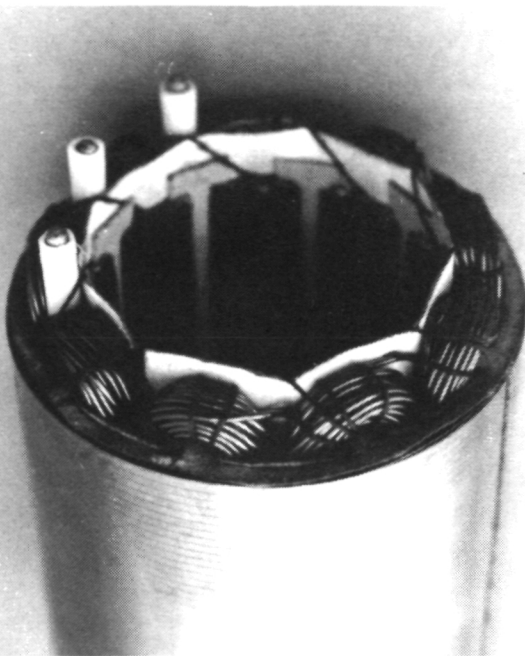

(a)



(b)

Figure 5-7. (a) Rewound Stator and (b) Rewound Stator after Potting and Encapsulation

SECTION VI

SECOND-GENERATION BEARING TEST STAND RESULTS

The second-generation bearing test rig consisted of a rotating stub shaft capable of either loading radial bearings up to 40 lb or loading thrust bearings up to 60 lb at speeds between 40,000 and 60,000 rev/min. Configurations tested included the current tilting-pad journal, Fogg thrust bearings, and Raleigh step thrust bearings, each with internal shaft supplied and external flooded lubrication. All configurations were successful at the maximum load capacity of the test stand, which was several times greater than the predicted design loads. The internally lubricated bearings were operated at 10% of their design lubricant flow rate at maximum load without damage. From these tests, it became apparent that the failures probably were not inherent to the specific bearing design or to the method of introducing the lubricant to the bearing, but were instead a TAP system-level problem.

SECTION VII

TAP TEST STAND COMPONENT PERFORMANCE EVALUATION

The purpose of the TAP test stand (Figure 7-1) was to determine the cause of the lower-than-predicted efficiency (25%) of the PCS and to establish the cause of the repeated bearing failures. The sources of both of these problems were isolated to the TAP system by various analytical and experimental results. Instrumentation of the TAP was simplified, and the time required to conduct tests was reduced by testing on the TAP test stand rather than by testing in the PCS.

The TAP test stand simulated every aspect of the TAP operating in the PCS with the exception of the shaft being externally mechanically driven rather than by supplying hot toluene vapor to the turbine. The external mechanical drive consisted of an electric motor and hydraulic pump driving a hydraulic motor and step-up gear box attached to a quill shaft on the turbine end of the TAP. Toluene was heated and pumped to the appropriate temperature and pressure, then supplied to the TAP at the proper flow rates. Tests were run at all inclinations between horizontal and vertical. Input power to the TAP was determined by mounting the TAP to low friction surfaces and measuring the reaction torque on the housing and shaft speed. Performance testing results indicated that the feed pump and PMA were operating substantially below their predicted efficiencies. The partial emission pump performance was improved by reducing the throat length of the diffuser. Increasing the pump back clearance from 10 to 20 mils resulted in no apparent reduction in performance; therefore, all future builds incorporated the larger clearance to prevent pump impeller contact and wear. Analysis by Maginetics indicated a complete PMA redesign would be required to correct its performance deficiencies.

TAP builds 12 and 13 incorporated the Rayleigh step thrust bearing and the rewound PMA with improved insulation encapsulated in a stycast material. The journal bearings were worn at the conclusion of tests on both TAP builds 12 and 13. This was as encouraging as a failure could be: Apparently, the same bearing failure that occurred in the PCS had been reproduced on the TAP test stand for the first time. This reproduced failure also reinforced the suspicion that the problem was within the TAP subsystem.

The bearing lubrication and rotor coolant channels within the rotating shaft were the most obvious unconventional aspect of the TAP design and were extensively analyzed by B-N, FACC, and JPL personnel. Because of the extreme complexity of the fluid dynamics, only a few general conclusions were made. Cavitation was occurring at the entrance of each radial bearing lube hole and limiting the amount of fluid delivered to each bearing. The combination of cavitation and fluid momentum introducing vapor and dividing the hydrodynamic film under the pad may have significantly altered the stiffness and damping of the bearings and thus introduced rotordynamic instabilities. Modifications made to reduce this possibility were: (1) to install small orifices at the exit of each radial lube hole to minimize cavitation in the lube channels (Figure 7-2), (2) to enlarge the jet pump exit and shaft lubricant inlet to

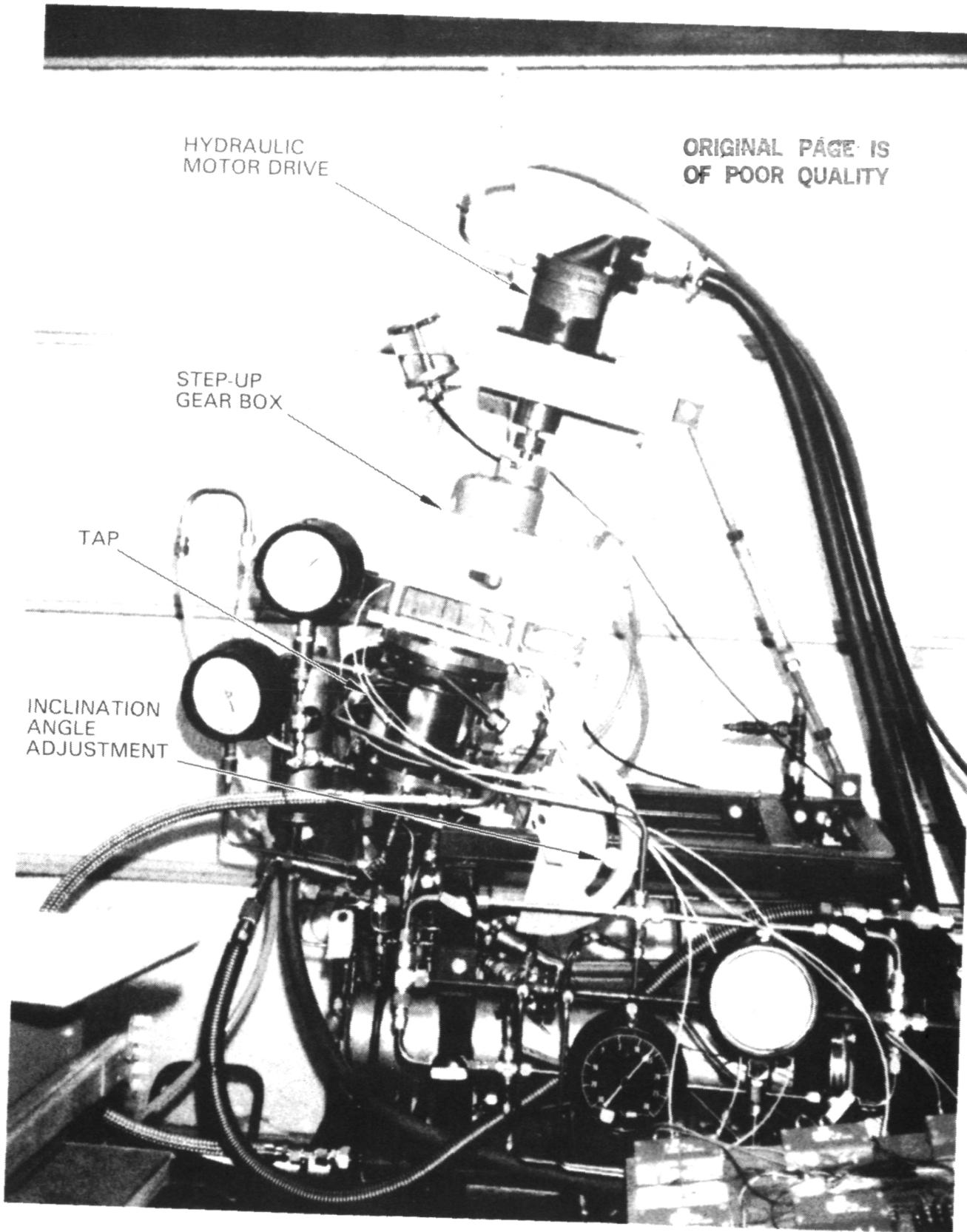

HYDRAULIC
MOTOR DRIVE

ORIGINAL PAGE IS
OF POOR QUALITY

STEP-UP
GEAR BOX

TAP

INCLINATION
ANGLE
ADJUSTMENT

Figure 7-1. TAP Test Stand

7-3

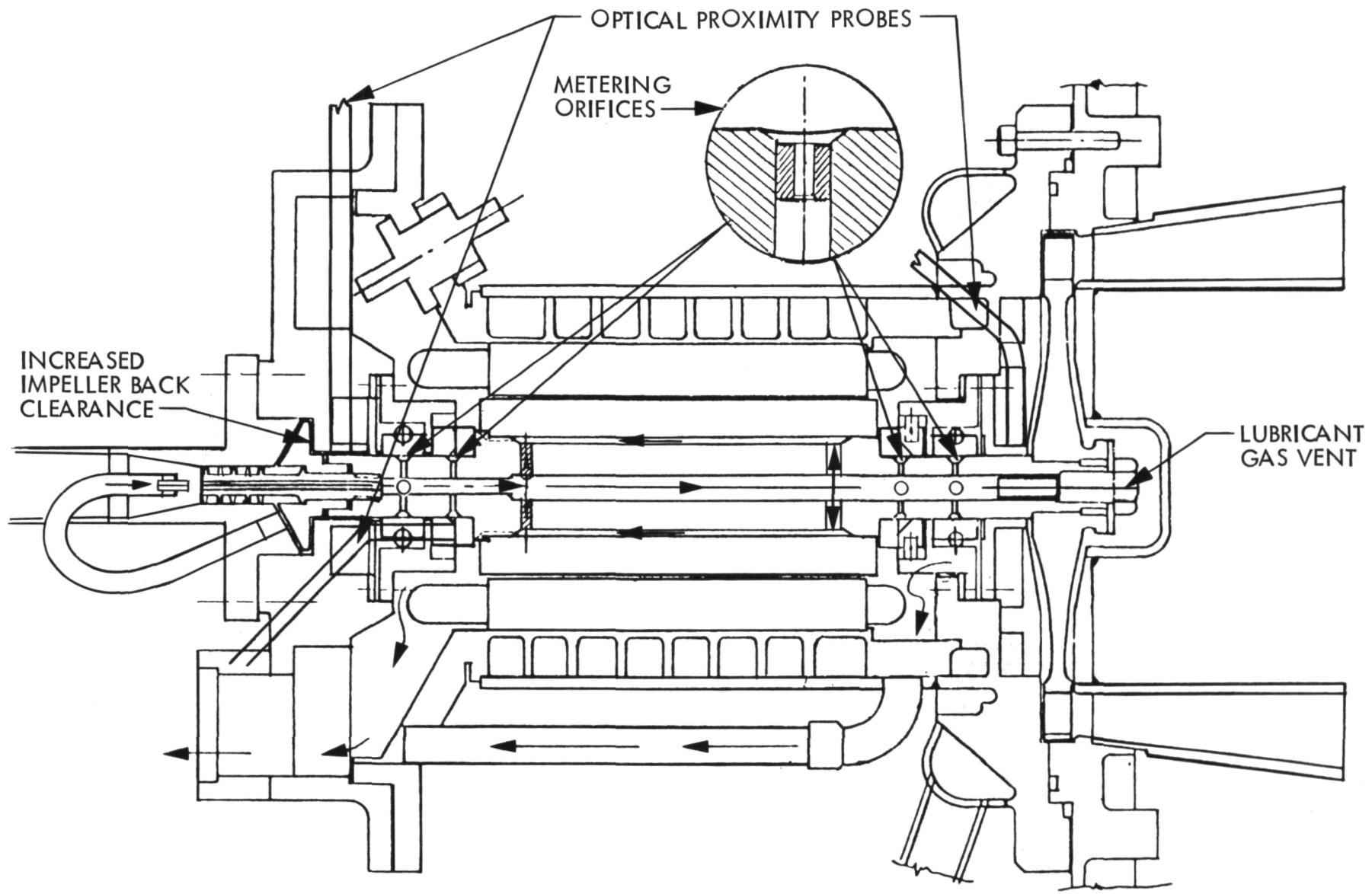

Figure 7-2. Metering Orifices Installed in each Radial Lubricant Hole (TAP Build 14)

increase total flow and pressure, and (3) to install a small vent on the shaft centerline at the turbine end to eliminate any possibility of trapped gases restricting flow to the bearings.

During this time, PMA performance was analyzed by Maginetics, and a number of design changes were recommended to improve the efficiency. Maginetic's recommendations included increasing the rotor diameter from 2.86 to 3.25 or 3.5 in. and changing from Inconel to carbon bands supporting the rotor magnets. Recommended modifications to the stator included increasing the slots from 9 to 18, reducing the lamination thickness from 5 to 2 mils, and changing to a Magnesil-N or Metglas alloy 2605. Efficiencies greater than 98% were predicted with these changes.

Feed pump modifications and additional instrumentation were incorporated into TAP build 14 to improve performance and monitor PMA and bearing conditions. Five optical proximity probes were installed at the recommendation of Caltech to track shaft position. Proximity probe outputs were recorded and evaluated on a spectrum analyzer. Two thermocouples were installed in the PMA stator and one thermocouple was placed in each radial and turbine end thrust bearing. As previously mentioned, modifications to the pump for TAP build 14 included an increased back clearance from 10 to 20 mils and a shorter diffuser throat for improved efficiency.

During operation of TAP build 14, the proximity probe data indicated a serious subsynchronous rotordynamic instability. Figure 7-3 gives the spectrum plot from a TAP optical proximity probe showing this effect. Disassembly and inspection revealed wear on the trailing edge of each tilting pad and polishing on the turbine end thrust bearing.

After extensive analysis of the proximity probe data, three concurrent courses of action were initiated in an attempt to resolve the rotordynamic instability problem. The squeeze-film-damped journal bearings (designed, installed, and tested by B-N) were the first to be tested because they had the shortest lead time (Figure 7-4). It was thought that by providing the proper amount of external damping to a simple journal bearing, the rotor bearing system could be stabilized. This was considered to be only a temporary fix to continue testing because vertical operation eventually would be required, and the journal bearing would probably be unstable in that position. The second parallel approach was a fully flooded five-pad tilting-pad journal bearing (from Waukesha Bearings Corporation) that was lubricated by externally supplied fluid from a dedicated bearing lube pump. This more conventional approach would eliminate all bearing and shaft dynamic uncertainties introduced by the lubrication system. A final backup approach was for Mechanical Technology, Inc. (MTI) to analyze and design a four-pad tilting-pad bearing and deliver drawings to Centritek for fabrication if the first two approaches failed.

TAP builds 15 through 19 incorporated two squeeze-film-damped journal bearings with external lubrication (Figure 7-5) and two internally lubricated thrust bearings.

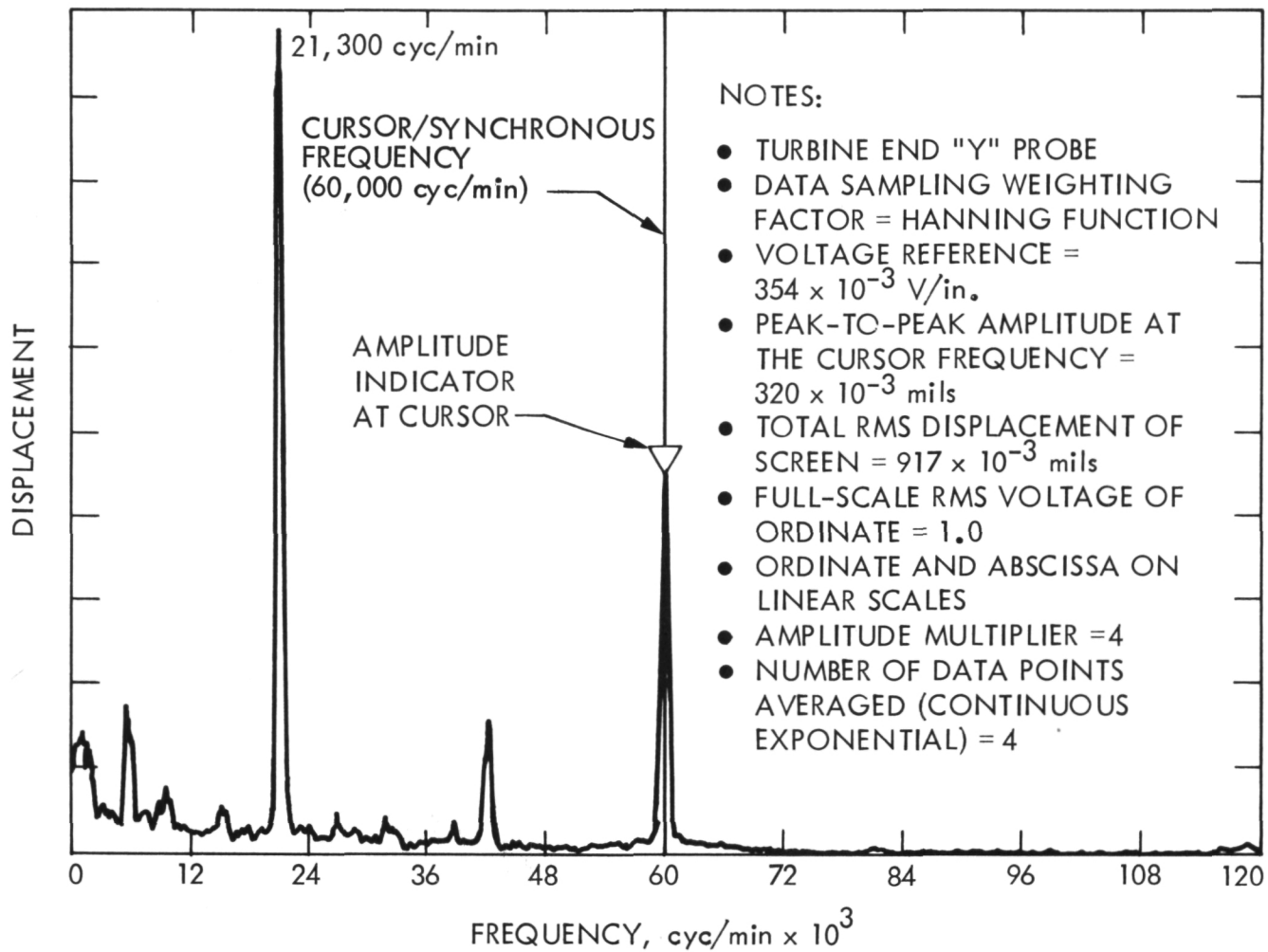
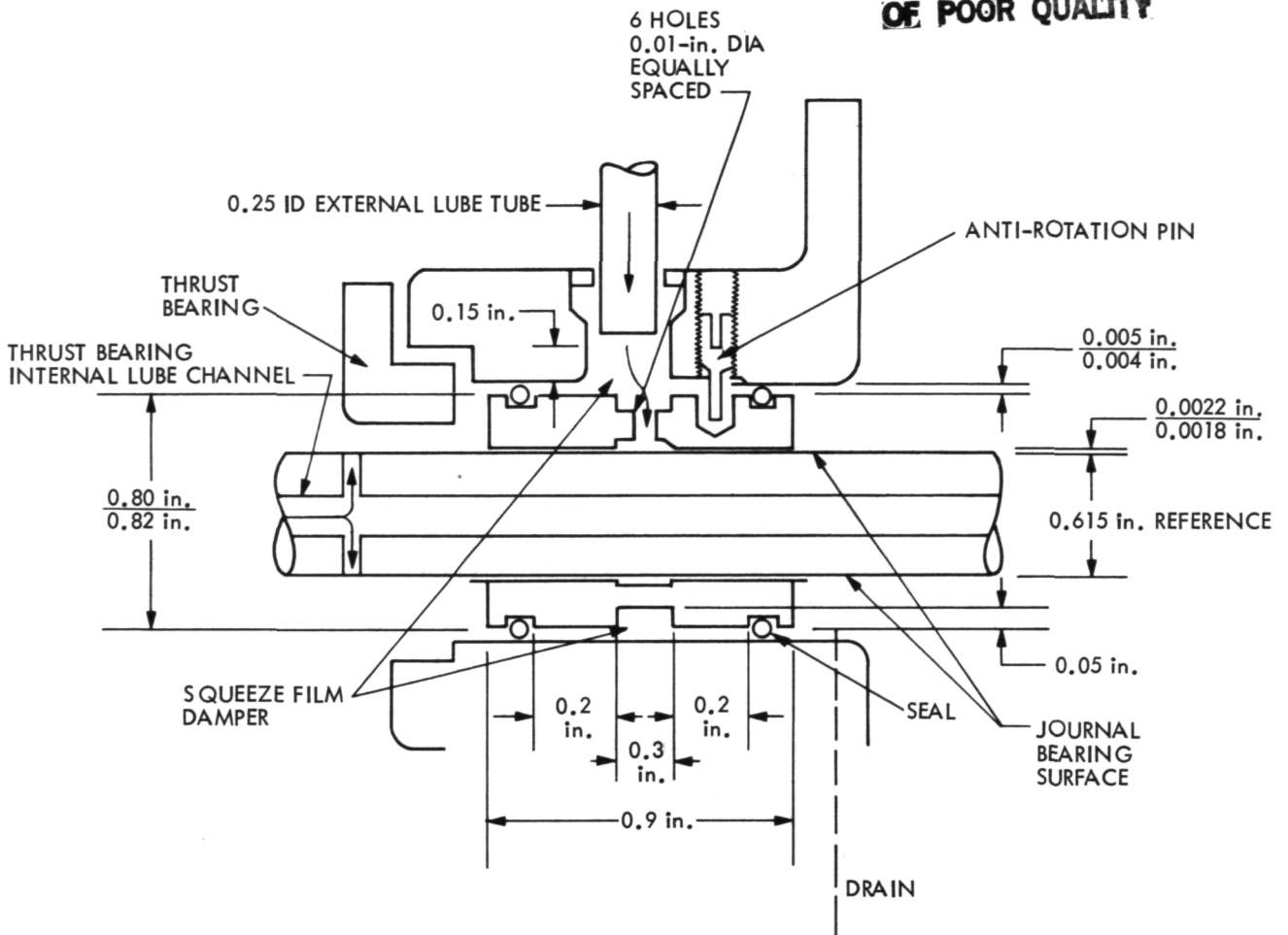

Figure 7-3. Spectrum Plot from Tests of a Barber-Nichols Three-Pad Tilting-Pad Bearing

ORIGINAL PAGE IS
OF POOR QUALITY



(a)



(b)



(c)

Figure 7-4. Squeeze-Film-Damped Journal Bearing (Stabilized Bearing)
(a) Schematic, (b) Journal Bearing with Elastic Damper Seals Attached, and (c) Complete Bearing and Carrier

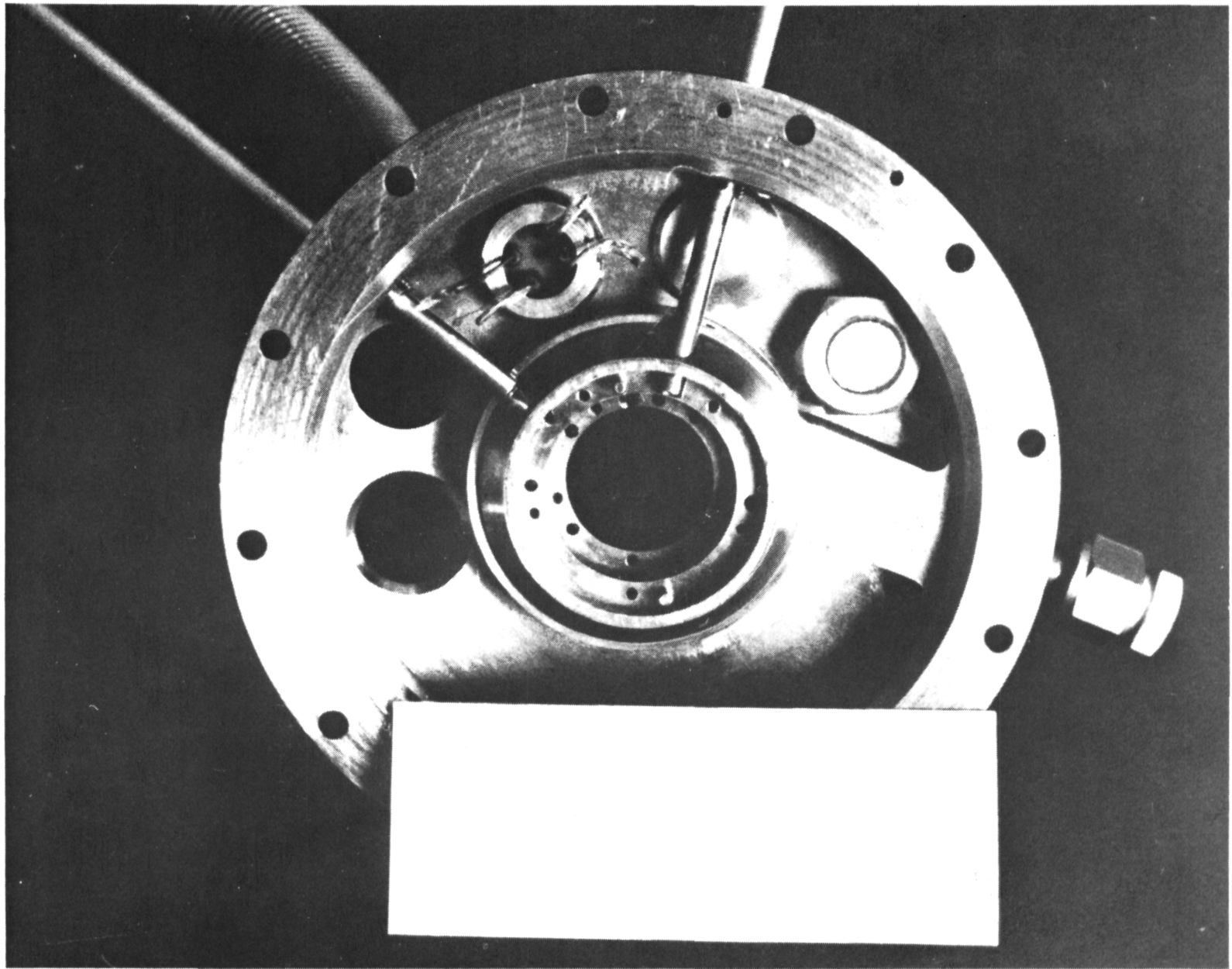

ORIGINAL PAGE IS
OF POOR QUALITY

Figure 7-5. Method of External Lubrication for Stabilized Bearings

The damping coefficient of the journal bearings was adjusted by changing the fluid leakage resistance path out of the damper section. This was essentially a trial-and-error process to minimize the total shaft displacement, which was a strong function of shaft speed and loading. Radial displacements as high as 8 mils observed in build 15 were reduced to between 1 and 2 mils in build 19 (Figure 7-6). The subsynchronous instability was never eliminated; however, the frequency and amplitude were decreased by adjustments to the squeeze-film-damped journal bearings. The compliance in the damper made the total displacement of the shaft greater for the squeeze-film-damped journal bearing than for the tilting-pad bearing. This resulted in thrust bearing wear caused by excessive angular displacement of the shaft.

Another problem observed was localized wear on the bearing surface, probably from unbalanced forces from the anti-rotation pin. Some surface distress was observed inside the damper section, possibly because of electrical discharge or cavitation. During operation of build 18 the PMA stator failed because of arcing between adjacent stator coils, which hurled a portion of the stycast material into the gap (Figure 7-7). The spare PMA was installed while a failure analysis was conducted by FACC (Reference 7-1). The arcing presumably was caused by sharp corners of interconnecting wire bundles cutting through insulating sleeves and subsequently damaging wire insulation. Because of the thrust bearing wear, surface distress in the damper, uncertainties with vertical operation, and availability of the alternative bearings, the squeeze-film-damped journal bearing tests were temporarily halted.

Tap builds 20 to 23 were tested, using fully externally lubricated thrust and Waukesha-supplied, five-pad tilting-pad journal bearings (Figure 7-8). Figure 7-9 shows how holes were placed in the lubrication grooves in the pump and turbine end thrust bearings, thus allowing flow from the flooded journal bearing lubricant reservoir onto the thrust bearing surfaces. Figure 7-10 shows both sides of the Waukesha five-pad tilting-pad journal bearing housing with one bronze end seal removed for better viewing. The five radial tubes delivered lubricant near the leading edge of each pad and maintained a fully flooded bearing housing. The same five tubes also functioned as anti-rotation pins for each pad. The two smaller pins in the figure are end seal anti-rotation pins. Figure 7-11 shows a pad from a Waukesha-designed five-pad tilting-pad journal bearing before and after testing. Waukesha fabricated the original pads and B-N duplicated their manufacturing capabilities for subsequent pads.

TAP build 20 was completed and set up; however, it was never operated, because of a decision to make additional modifications to the pump end bearing seal rings. After these modifications, now designated build 21, the TAP was operated 10 min when a facility circuit breaker powering the lubricant pumps opened. Lubrication flow to the bearings was interrupted while the drive system on a separate circuit breaker continued to operate for 5 to 10 s. The scheduled 1-h test was continued after additional power-loss preventive measures were incorporated with the hope that the bearings were not destroyed during the test anomaly. The proximity probe data indicated no subsynchronous whirl problem before or after the loss of lubricant. This was observed when identical proximity probe signatures were obtained before and after the failure. Unfortunately, the bearings were damaged, making it impossible to determine if the actual cause was attributable to some aspect of the bearing design or to the temporary loss of lubricant to the bearings.

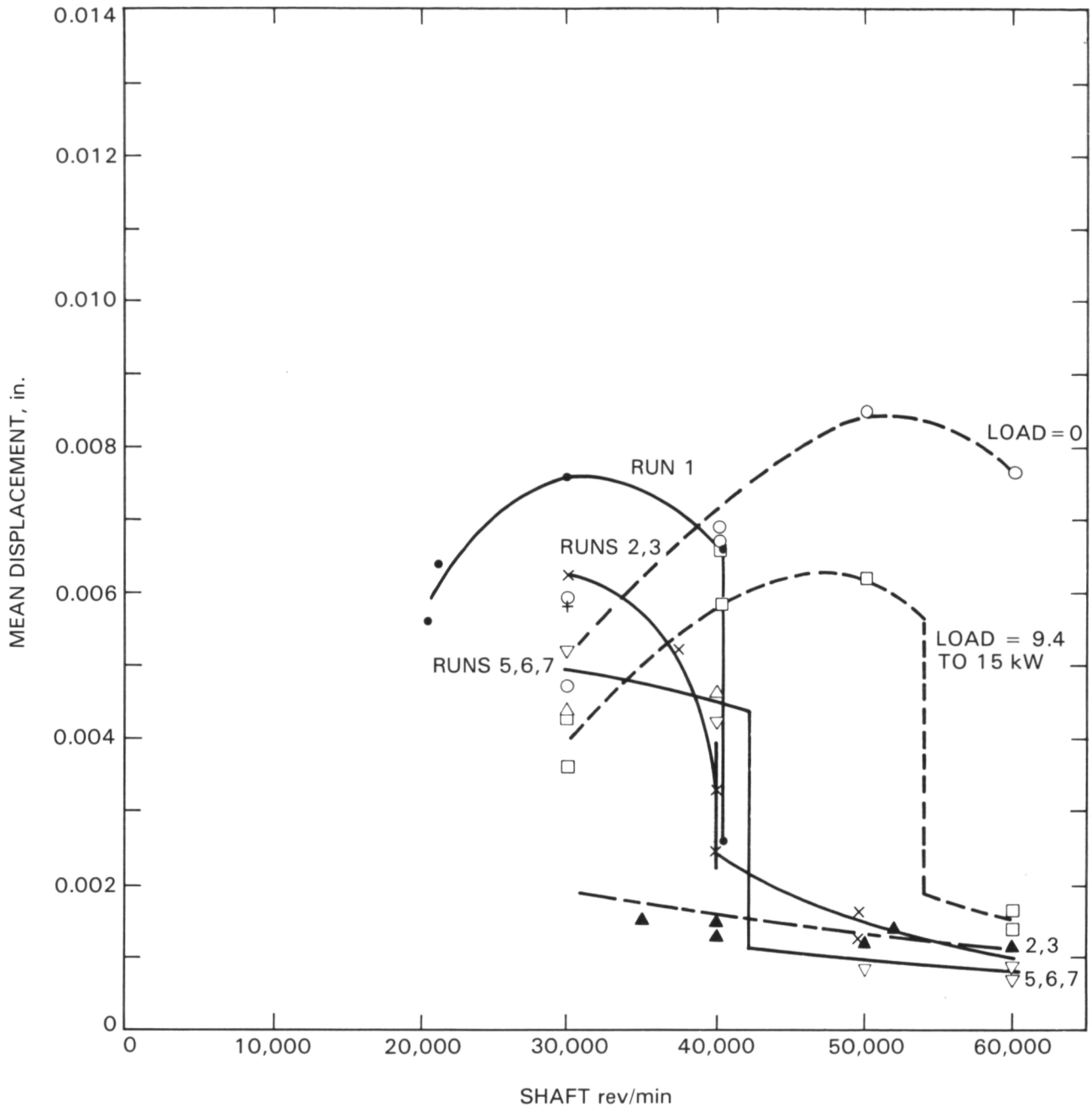

BUILD 17

- RUN 1 HOR LOAD = 0
- × RUN 2 HOR LOAD = 9.4 kW_e
- + RUN 3 HOR "
- △ RUN 5 VERT (75°) "
- ▽ RUNS 6,7 VERT (75°) "
- 1 BOOST PUMP

BUILD 15

- RUN 2 HOR LOAD = 0
- RUN 2 HOR LOAD = 9.4 TO 15 kW_e
- 1 BOOST PUMP
- ▲ BUILD 19 VERT (75°) LOAD = 9.4 kW_e

Figure 7-6. Total Shaft Displacement with the Squeeze-Film-Damped Journal Bearing

ORIGINAL PAGE IS
OF POOR QUALITY

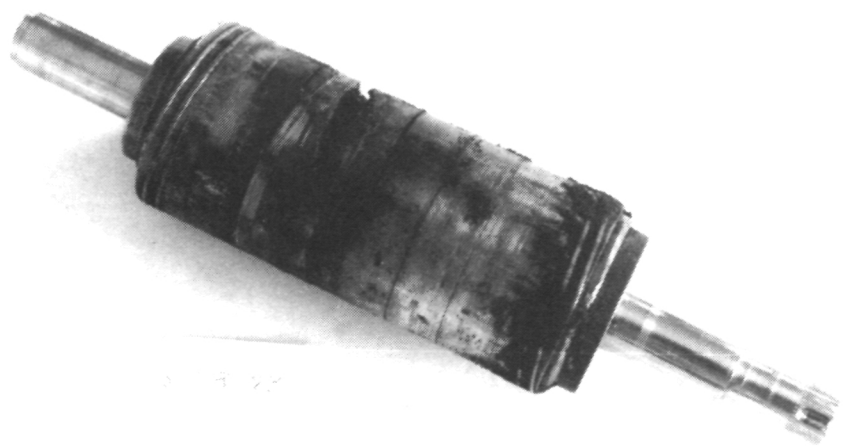
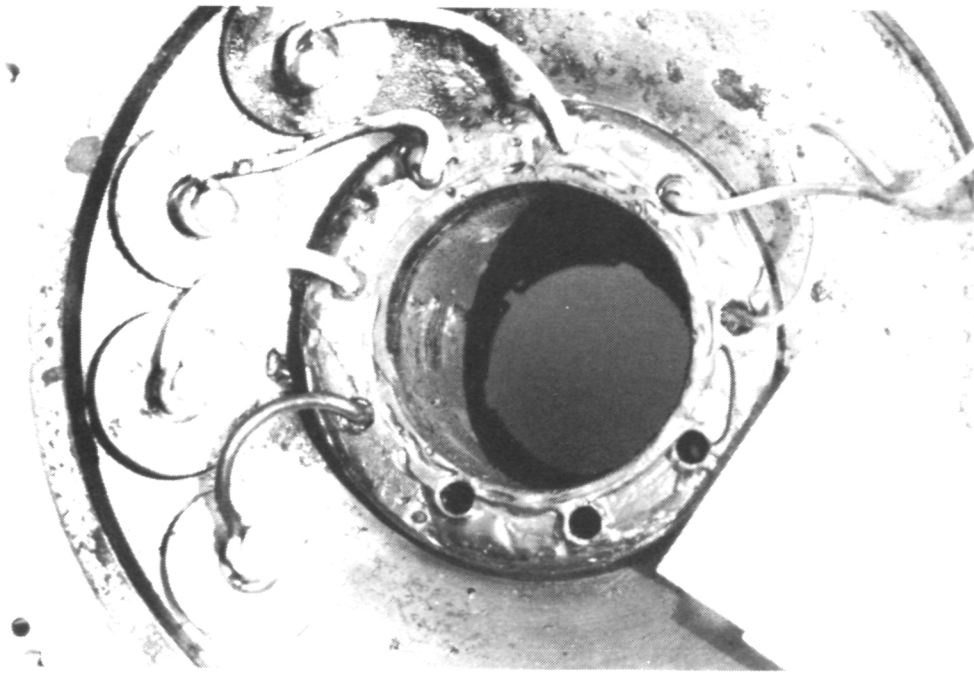

Figure 7-7. Permanent Magnet Alternator Failure Caused by Arcing between Adjacent Stator Coils

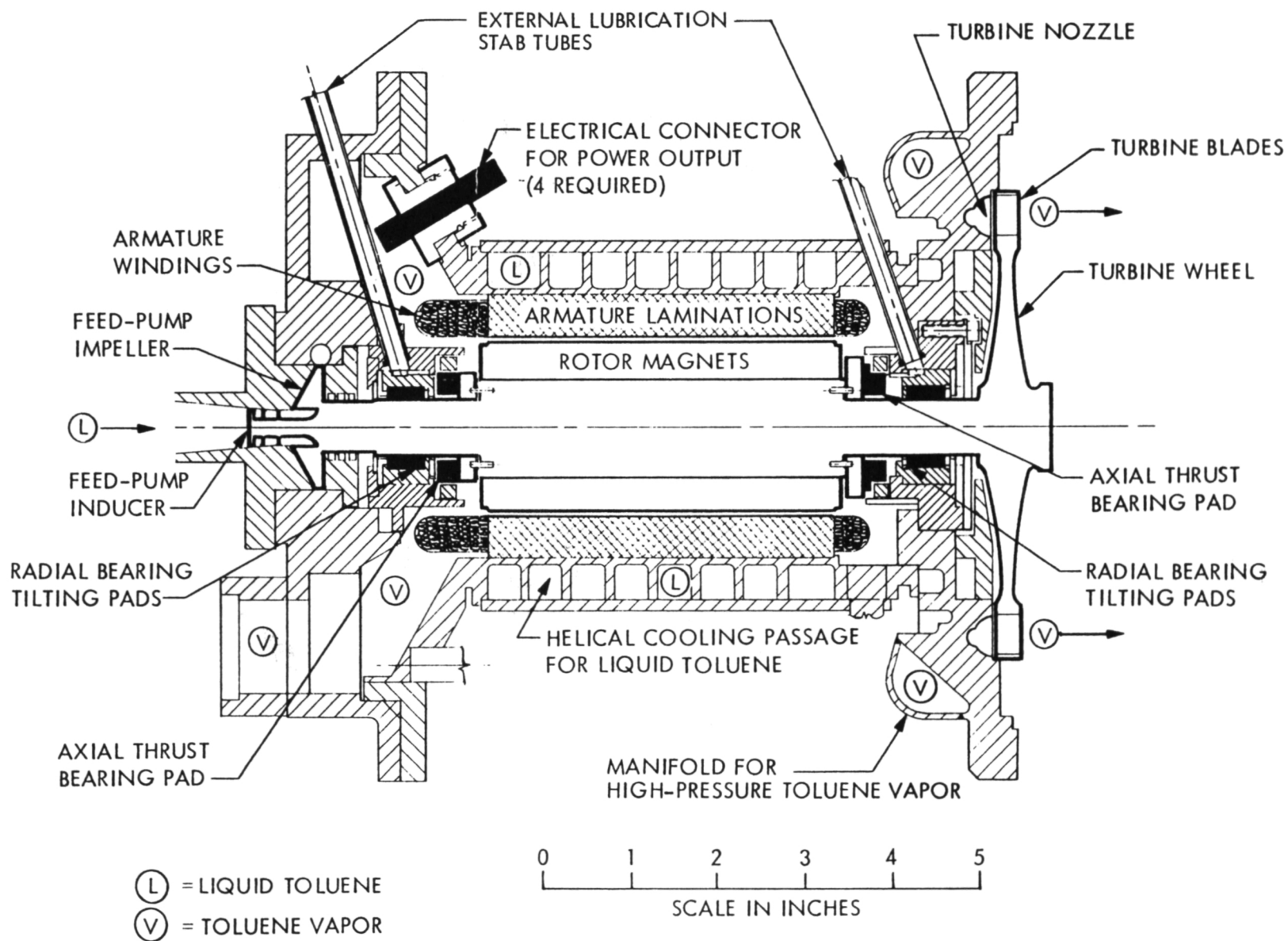

Figure 7-8. Externally Lubricated: Waukesha Five-Pad Tilting-Pad Journal Bearings and Fogg Flat Pad/Raleigh Step Thrust Bearings

ORIGINAL PAGE IS
OF POOR QUALITY

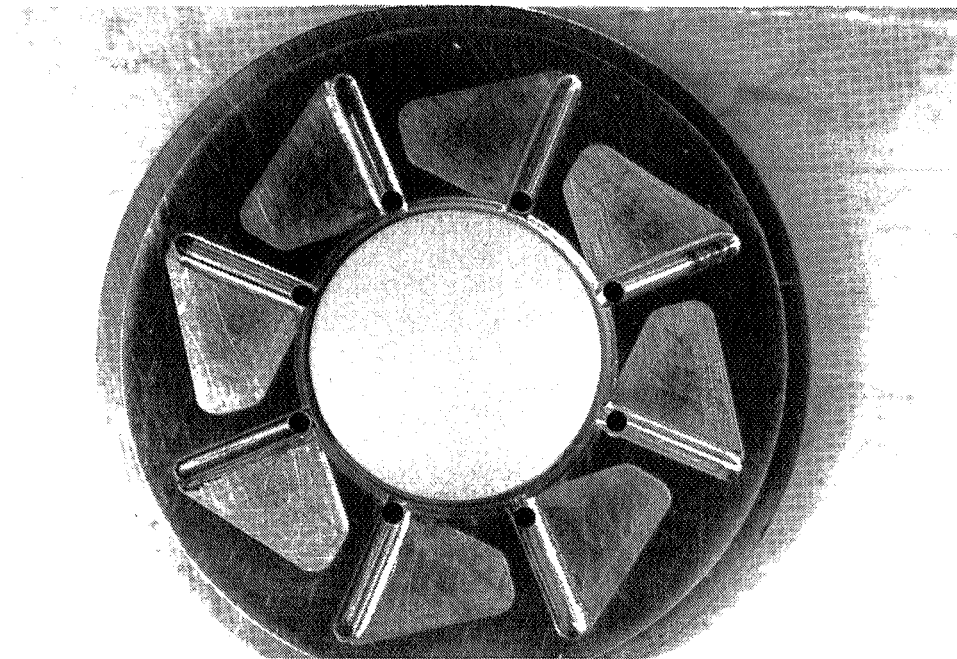
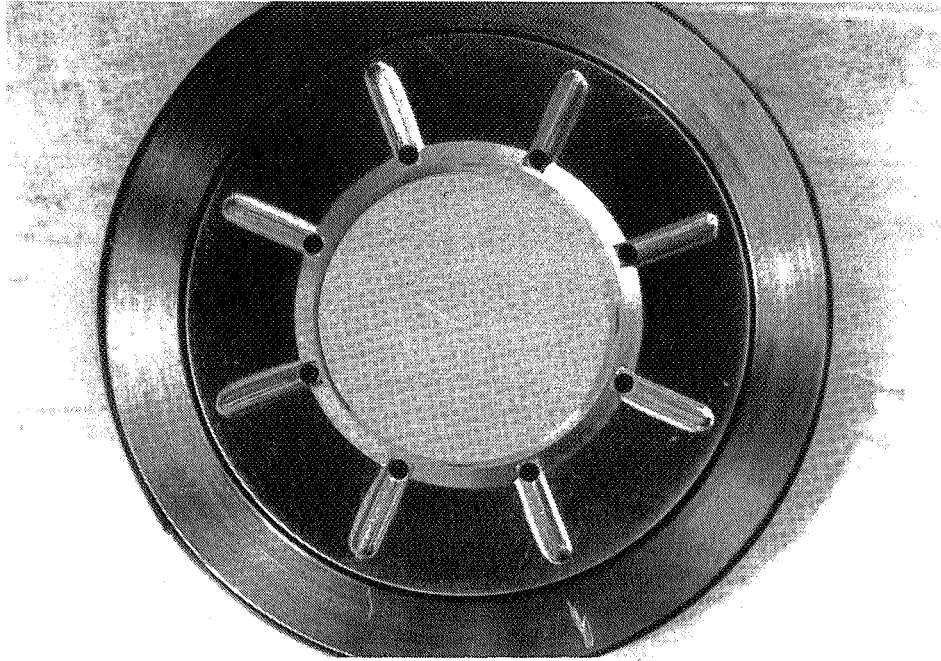
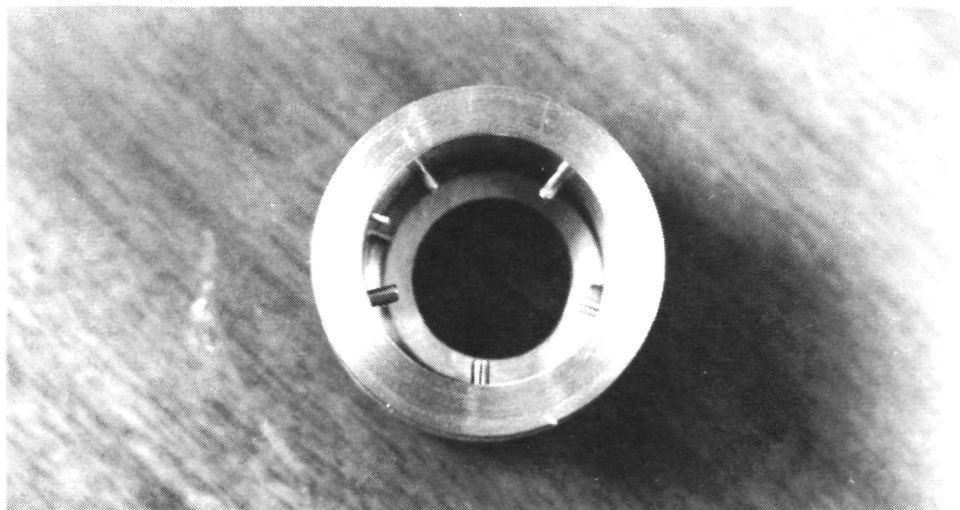

Figure 7-9. Externally Lubricated Thrust Bearings

ORIGINAL PAGE IS
OF POOR QUALITY



(a)



(b)

Figure 7-10. Waukesha Five-Pad Tilting-Pad Journal Bearing Housing

7-14

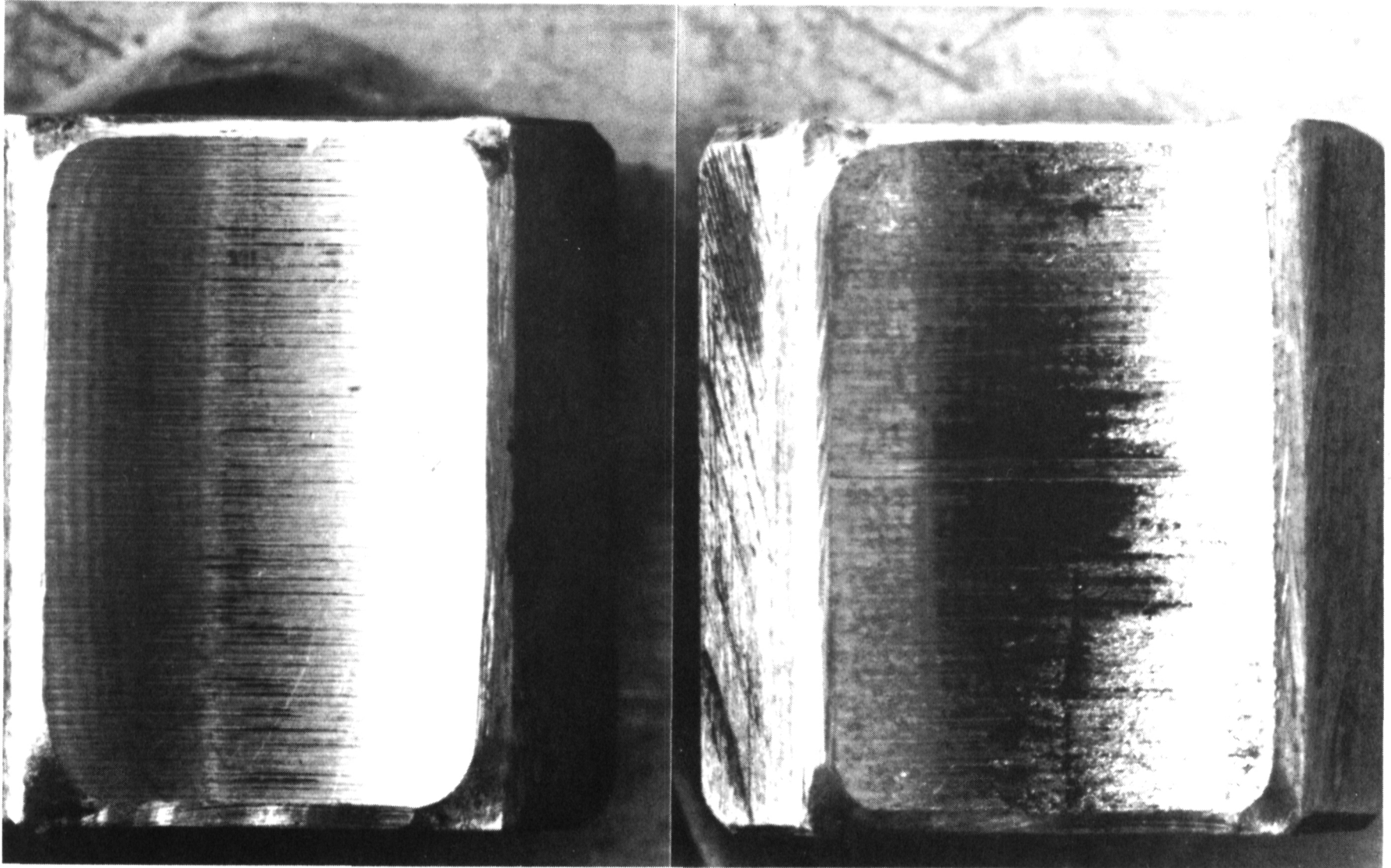

(a)

(b)

Figure 7-11. Waukesha Journal Bearing Pad (a) Before and (b) After Testing

ORIGINAL PAGE IS
OF POOR QUALITY

An extensive analysis of the build 21 damaged bearing surfaces was conducted by FACC using an electron beam microscope. The damaged surface on each pad had a frosted appearance, which was determined to be a number of separate but closely packed pits. Figures 7-12 and 7-13 show various magnifications of the pitted surfaces and compare them to unpitted zones. A chemical analysis inside the pits revealed high concentrations of zinc and chlorine, which were not present in the virgin babbitt or bearing material. This change is shown in Figure 7-14 where the virgin material analysis and an analysis inside a single pit are compared on one plot.

Determining the source and mechanism of transferring zinc to the bearing surface became the primary concern (a grounding strap was placed on the shaft turbine end center line prior to TAP build 2, and it remained intact for all PCS tests). Similarly, all test stand testing required an external drive shaft, which was grounded to the test stand. These two facts were the primary reasons for dismissing electrical discharge as a failure mechanism in earlier TAP builds. It also seemed apparent that the subsynchronous whirl and subsequent bearing wear may have destroyed most of the evidence of the frosted and pitted surface. The evidence was overwhelming, pointing to some form of electrical discharge as the mechanism of zinc transfer and the source of the material seemed to be the brass end seals. These seals maintained the lubricant around the bearings and operated in close proximity to the rotating shaft and the non-rotating bearings. Further analysis indicated that the grounded shaft would prevent electrostatic buildup and discharge but would not necessarily prevent electrodynamic discharges generated by the PMA. It was suspected that the PMA was generating and circulating stray current around a closed loop from the PMA stator to one set of bearings, to the shaft (or ground) to the other set of bearings, then back to the PMA stator.

One possible method of isolating the PMA as a cause of the bearing failure was to operate the TAP with a non-magnetic rotor. TAP build 22 was identical to TAP build 21 with the exception that a non-magnetic PMA rotor was installed. Tests were run over a wide speed range and zero electrical load due to the non-magnetic rotor with very small well-behaved shaft orbits. There were no signs of rotordynamic instabilities in the proximity probe data. Inspection of the bearings at the conclusion of the tests revealed no wear or damage to the bearing pads. Because TAP build 22 was successful without a magnetic rotor and no loss of lubricant to the bearings, it was still necessary to verify that the bearing failure in TAP build 21 with a magnetic rotor was or was not caused by loss of lubricant to the bearings.

TAP build 23 was assembled with a magnetic rotor in place and tested for 5 min at 40,000 rev/min delivering 9.4 kWe. Proximity probe data indicated no rotordynamic instabilities were present and that shaft orbits were very small. Five minutes into the run, two or three apparently high electrical loads jolted the TAP severely, thereby reducing the operating speed and causing extreme excursions in the shaft orbit. Subsequent disassembly and inspection revealed a failure of two of the four electrical feed-throughs on the interior side of the hermetically sealed system (Figure 7-15). These glass feed-throughs passed the three phases and a neutral wire from the toluene vapor environment to the outside cabling. Because the two failed feed-throughs were vertically in line with one another, a number of failure scenarios were developed in which (because of electrical resistance overheating or of overheating while soldering the exterior connection) the

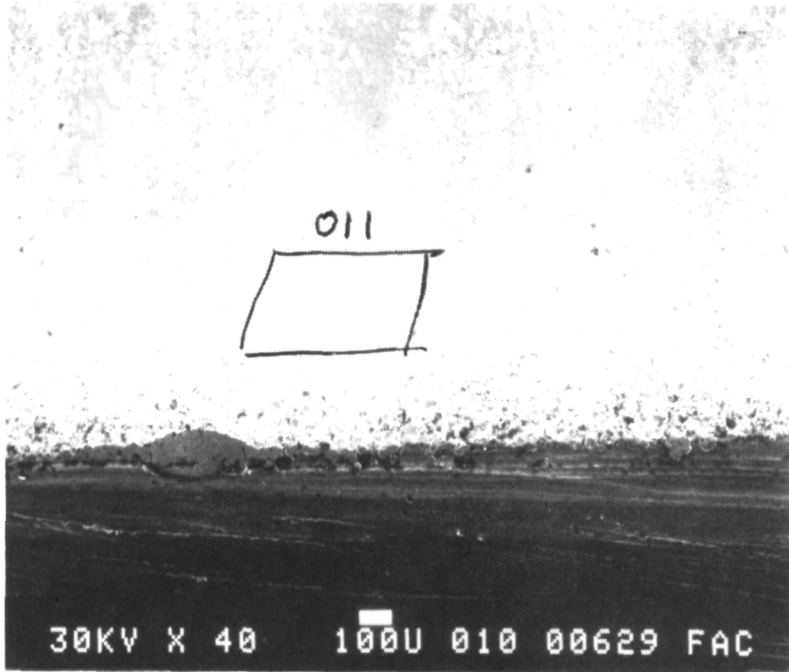

MAGNIFICATION: 40x

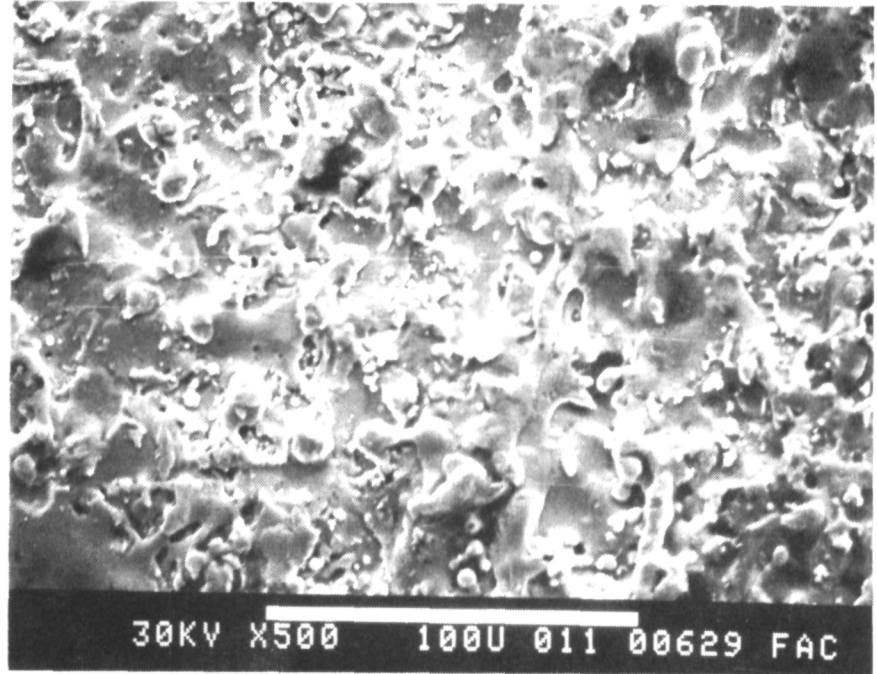

MAGNIFICATION: 500x

Figure 7-12. Trailing Edge Surface of a Waukesha Pad with Electrical Discharge Pitting

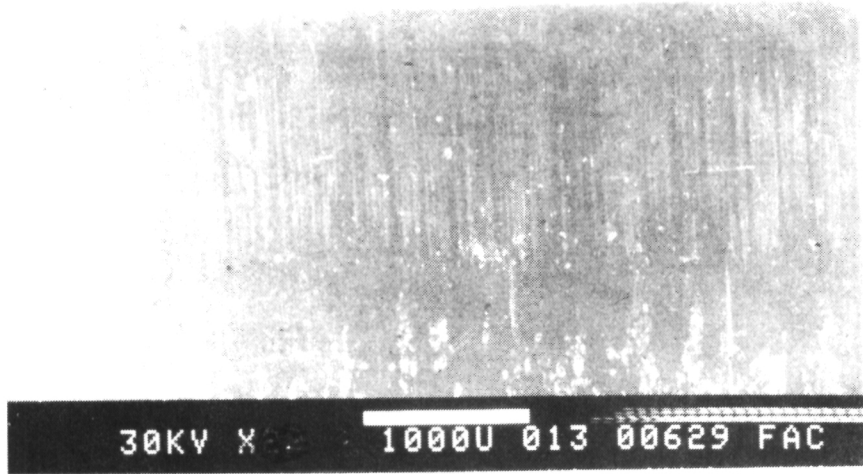

MAGNIFICATION: 44x

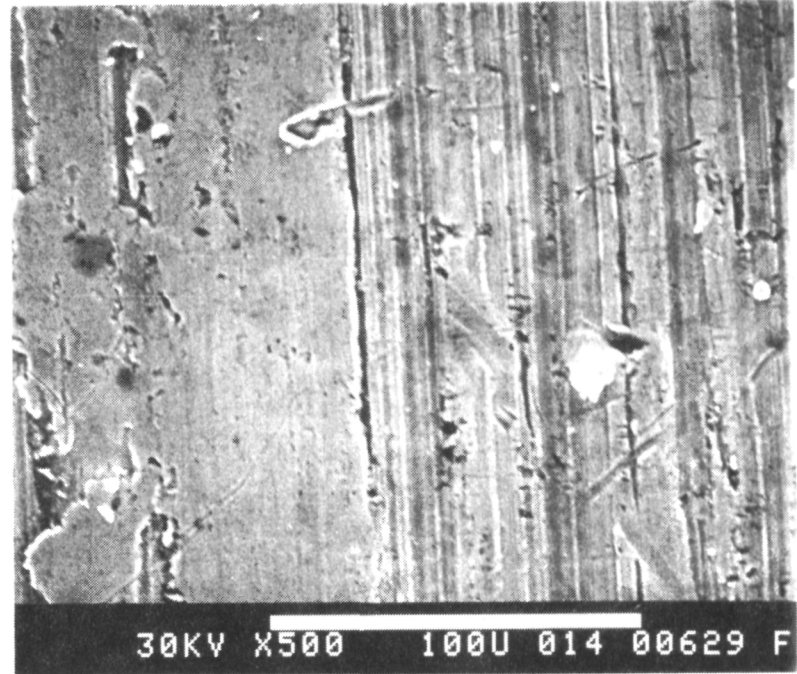

MAGNIFICATION: 500x

Figure 7-13. Leading Edge Surface of a Waukesha Pad without Electrical Discharge Pitting

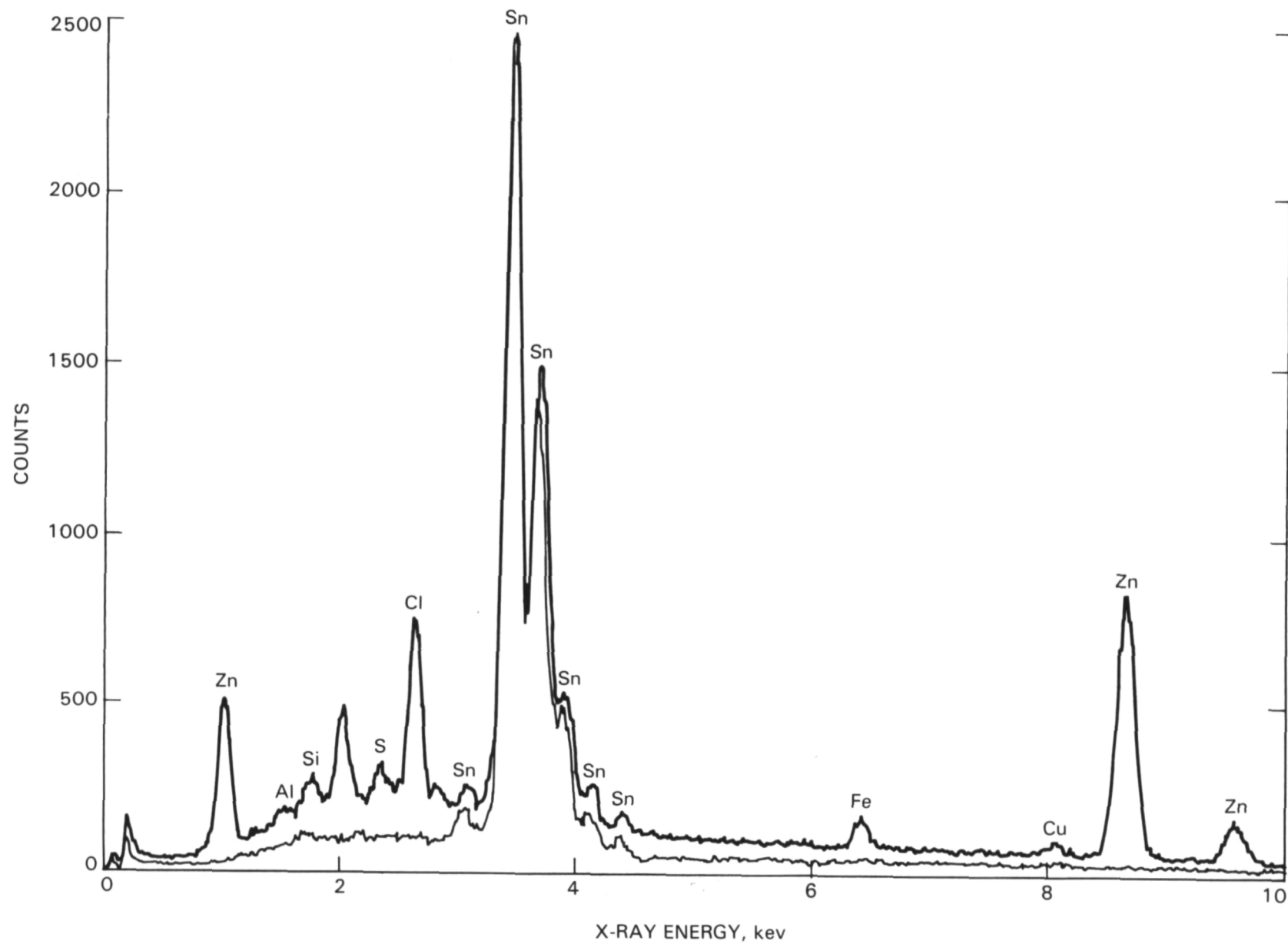
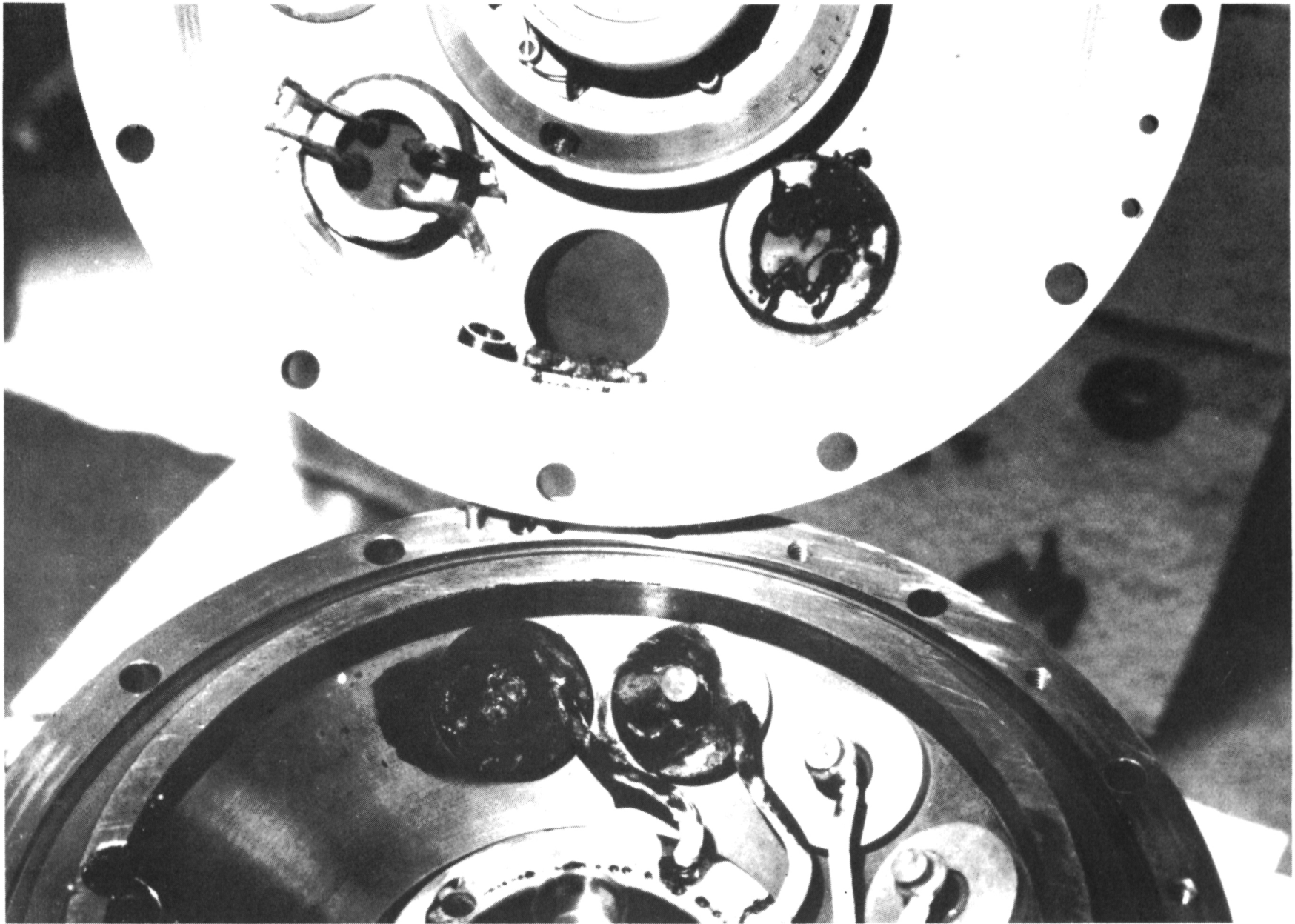

Figure 7-14. Comparison of Pitted (upper line) and Unpitted (lower line) Surface X-ray Spectrums from a Scanning Electron Microscope in Spot Mode. Note the Higher Zn and Cl Concentration in Pitted Surface



ORIGINAL PAGE IS
OF POOR QUALITY.

Figure 7-15. TAP Build 23 Electrical Feed-Through Failures of the Neutral and One of Three Phases from the Permanent Magnet Alternator

power phase may have dripped material onto the neutral, causing a simultaneous failure. Unfortunately, the failure damaged the bearings and invalidated the test to determine if and in what manner the magnetic rotor effected bearing wear.

Immediately following the inspection of TAP build 23, B-N was directed to terminate all work on 5-27-83 because of funding constraints. The stop-work order remained in effect for approximately 12 weeks, during which time B-N, under its own funding, resumed testing the squeeze-film-damped journal bearings. B-N took this approach because this bearing was viewed as a potential near-term, low-cost solution to the bearing problem. The disadvantages of these bearings were the probable reduced bearing life because of failure of the elastic liquid damper seals and the uncertainty of stable operation of these bearings in the vertical shaft position. Half-speed whirl instabilities are a common problem in simple journal bearings when operated with no load, as is experienced in the vertical shaft position. There is no reason to believe that a squeeze-film-damped journal bearing would not be susceptible to the same problem. TAP build 24 was run in the horizontal position with the B-N-designed, squeeze-film-damped journal bearings and a non-magnetic alternator rotor but without the feed pump. Inspection of the bearings at the conclusion of the test revealed no bearing wear with a non-magnetic rotor. Absence of bearing wear in TAP build 24 was consistent with TAP build 22 test results with the fully externally lubricated Waukesha bearings and a non-magnetic rotor. When the non-magnetic rotor was replaced with a magnetic rotor (as was done in TAP build 25), bearing wear and distress were observed. This was the first time a set of fully externally lubricated bearings had been tested in the TAP with a non-magnetic and magnetic rotor with no test anomalies. Successful bearing test results with a non-magnetic rotor and failed bearings following an identical test with a magnetic rotor indicated the remaining bearing problems were electromagnetic-related.

The previously described process of electrical discharge across bearing surfaces was addressed in TAP build 26. A set of electrically insulated bearing carriers was fabricated. A copper grounding strap was added to further ensure that the shaft was grounded independently of the shaft drive system. Inspection of the TAP, following 1.1 h of horizontal operation delivering electrical power, revealed no bearing wear; however, an unrelated problem discovered was a small portion of the PMA coating material (stycast) separated from the stator and coated one-third of the rotor.

In TAP build 27 the rotor and stator were cleaned and checked, and the feed pump was reinstalled. After 1.3 h of testing, TAP inspection revealed no bearing damage; however, electrical arcing occurred between the pump back shroud and a pump end journal bearing seal. A new pump back shroud was fabricated, and the pump end bearing seal and proximity probes were removed for TAP build 28. Inspection of TAP build 28 (after 1 h of operation) revealed no change in the bearings or any other component.

TAP build 29 was identical to 28 and was run for 1 h in a horizontal position (0°) and 1 h at an altitude angle of 75° , again with no bearing wear or component damage. This was the final test of the B-N-designed, squeeze-film-damped journal bearing because of uncertainties of operation in the vertical-shaft position and lifetime of the elastic damper seals.

ORIGINAL PAGE IS
OF POOR QUALITY

The five-pad Waukesha tilting-pad bearings, using B-N-fabricated pads and mounted in an electrically insulated nylon bearing carrier (Figure 7-16), were used in TAP builds 30 to 35 with essentially no changes. Figure 7-17 shows the pump and turbine end thrust bearings mounted on the insulated bearing carriers and provides a good view of the grooves that disperse the lubricant over the bearing face and the holes supplying fluid from the flooded bearing reservoir to the grooves. A total of approximately 21 h of operation were accumulated on these builds with no bearing distress or electrical arcing. The success of these tests at various altitude angles from horizontal to vertical and various powers and speeds indicated that the bearings were ready for hot testing in the engine.

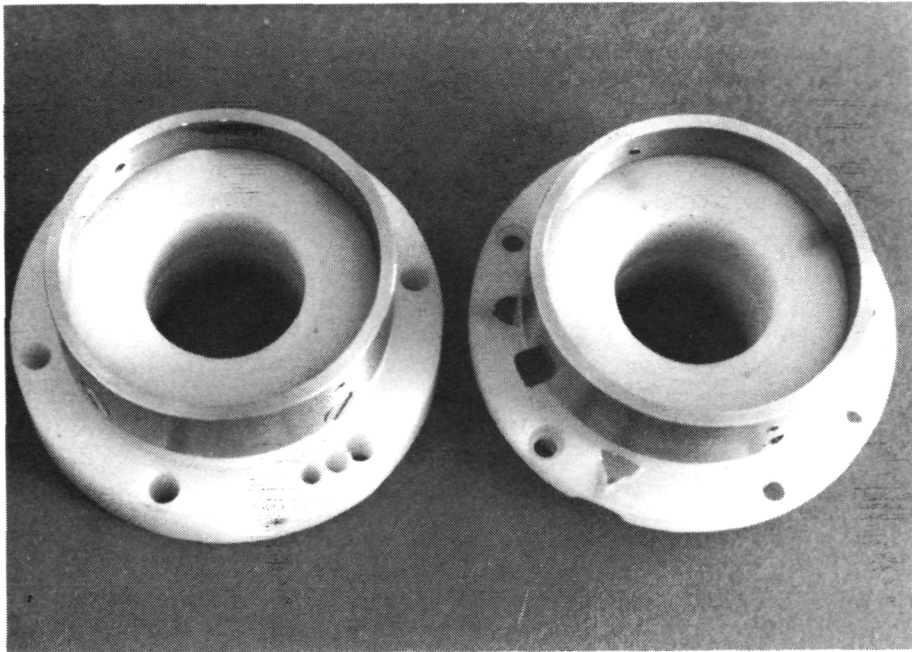
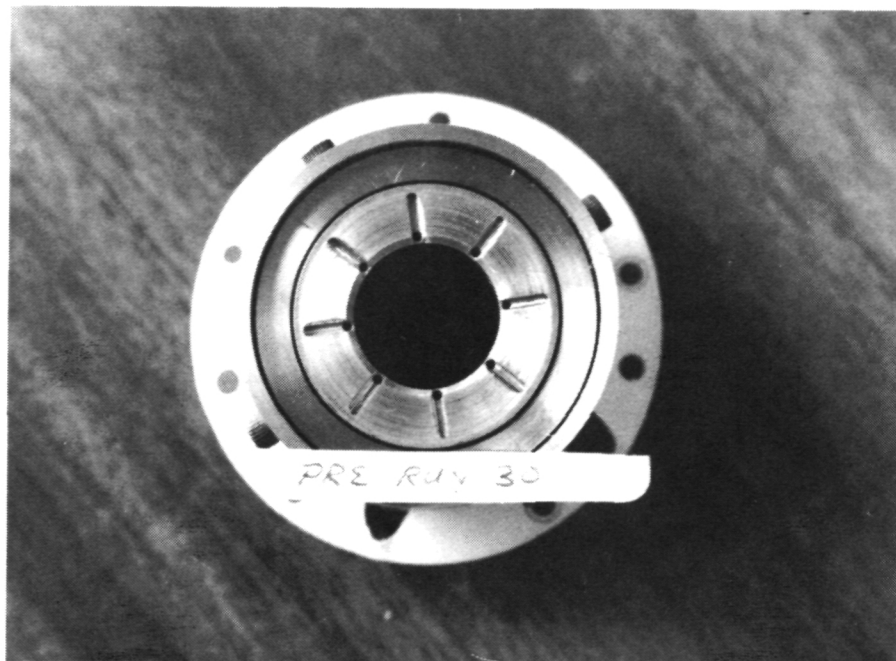

Figure 7-16. Electrically Insulated Bearing Carriers

ORIGINAL PAGE IS
OF POOR QUALITY



(a)



(a)

Figure 7-17. Electrically Insulated Bearing Carriers with (a) Pump End and (b) Turbine End Thrust Bearings Mounted

SECTION VIII

COMPLETE POWER CONVERSION SUBSYSTEM 100-h TEST AT BARBER-NICHOLS

In these tests the primary objective was to operate the PCS for 100 h to simulate as closely as possible the actual operating conditions of the bearings during on-sun operation. These tests were conducted at B-N using the electrical resistance toluene boiler with upgraded insulation. Test goals and accomplishments are shown in Table 8-1. The time spent at power levels above and below 70 kWt, at idle, and at various altitude angles are representative of typical conditions on a solar concentrator. The numerous hot and cold starts were conducted to demonstrate bearing lift-off capabilities and start-up transient operation. Numerous full-speed emergency stops using the electrical break demonstrate another transient bearing loading condition that required testing. Detailed test results and photographs of the actual hardware can be found in Reference 8-1.

TAP build 36 was tested in the complete engine inclined at 45 deg with hot toluene supplied by an electrical resistance boiler. Waukesha-fabricated bearings and pads were used, and new thrust bearings were fabricated to begin the test with all new bearings. These bearings were mounted into a new electrically insulated bearing carrier fabricated from Ryton PPS (polyphosphazene sulfide), which is a high-temperature toluene compatible bakelite material from Philips. A copper beryllium grounding strap was placed in contact with the button on the center line of the shaft at the turbine end. The engine operated for 5 min when a loud 15-s screech was heard, and the engine was shut down. The screech appeared on the proximity probe data at a frequency just below synchronous. Disassembly and inspection revealed no damage to bearings or any other component. Some type of feed pump instability was suspected as the cause of the noise.

TAP build 37 incorporated (1) an additional boost pump to prevent pump instabilities and (2) the B-N-fabricated pads used in the previous 21-h TAP test stand tests (TAP builds 30 through 35). An accelerometer was installed to monitor any additional vibrations. TAP build 37 was operated for 20 h at 45-deg inclination with no problems. Disassembly and inspection revealed no bearing wear or other component failures.

TAP build 38 was identical to the previous build and operated for 34 h in the vertical shaft position. No bearing wear was observed at the conclusion of this test, but two of the pump-end bearing pads seemed to have an inadequate bond between the steel shoe and the babbitt surface coating. This was apparently due to a processing problem and was not related to the testing.

TAP build 39 was identical to the previous build with the exception that two of the pump end bearing pads with a process bonding problem were replaced. The engine was operated for 4 to 7 h at an inclination angle of 5 deg. This completed the 100-h test plan, with the only deviation being in the distribution of hours between the various altitude angles. This change was made so that one additional disassembly and inspection could be eliminated,

Table 8-1. Power Conversion Subsystem 100-h Test Accomplishments

	GOAL	ACCOMPLISHMENT
TOTAL RUN TIME	100 HOURS	101 HOURS
RUN TIME AT AN INPUT POWER LEVEL $>70 \text{ kW}_{\text{TH}}$	60 HOURS	60.4 HOURS
RUN TIME AT AN INPUT POWER LEVEL $<70 \text{ kW}_{\text{TH}}$	35 HOURS	35.6 HOURS
RUN TIME AT IDLE CONDITION (35,000 RPM AND NO ELECTRIC LOAD)	5 HOURS	5 HOURS
TOTAL NUMBER OF STARTS	50	52
TOTAL NUMBER OF COLD STARTS	10 (MINIMUM)	11
TOTAL NUMBER OF HOT STARTS	25 (MINIMUM)	41
RUN TIME AT PCS ATTITUDE OF 45°	50 HOURS	20 HOURS
RUN TIME AT PCS ATTITUDE OF 90°	25 HOURS	34.4 HOURS
RUN TIME AT PCS ATTITUDE OF 5°	25 HOURS	46.8 HOURS
FULL SPEED STOPS USING OVERSPEED BRAKE	5 (MINIMUM)	9

allowing the 100-h test results to be available for the November 1, 1983, DOE-scheduled ORC review. The only effect this had was that additional hours were run at 5 and 90 deg, and fewer hours were run at 45 deg. Figures 8-1 and 8-2 are shaft displacement amplitude versus frequency for TAP builds 38 and 39 (90- and 5-deg inclination) using comparable amplitude scales. Results of the test showed inclination angle does not seem to affect shaft dynamics and no bearing wear or component damage was observed.

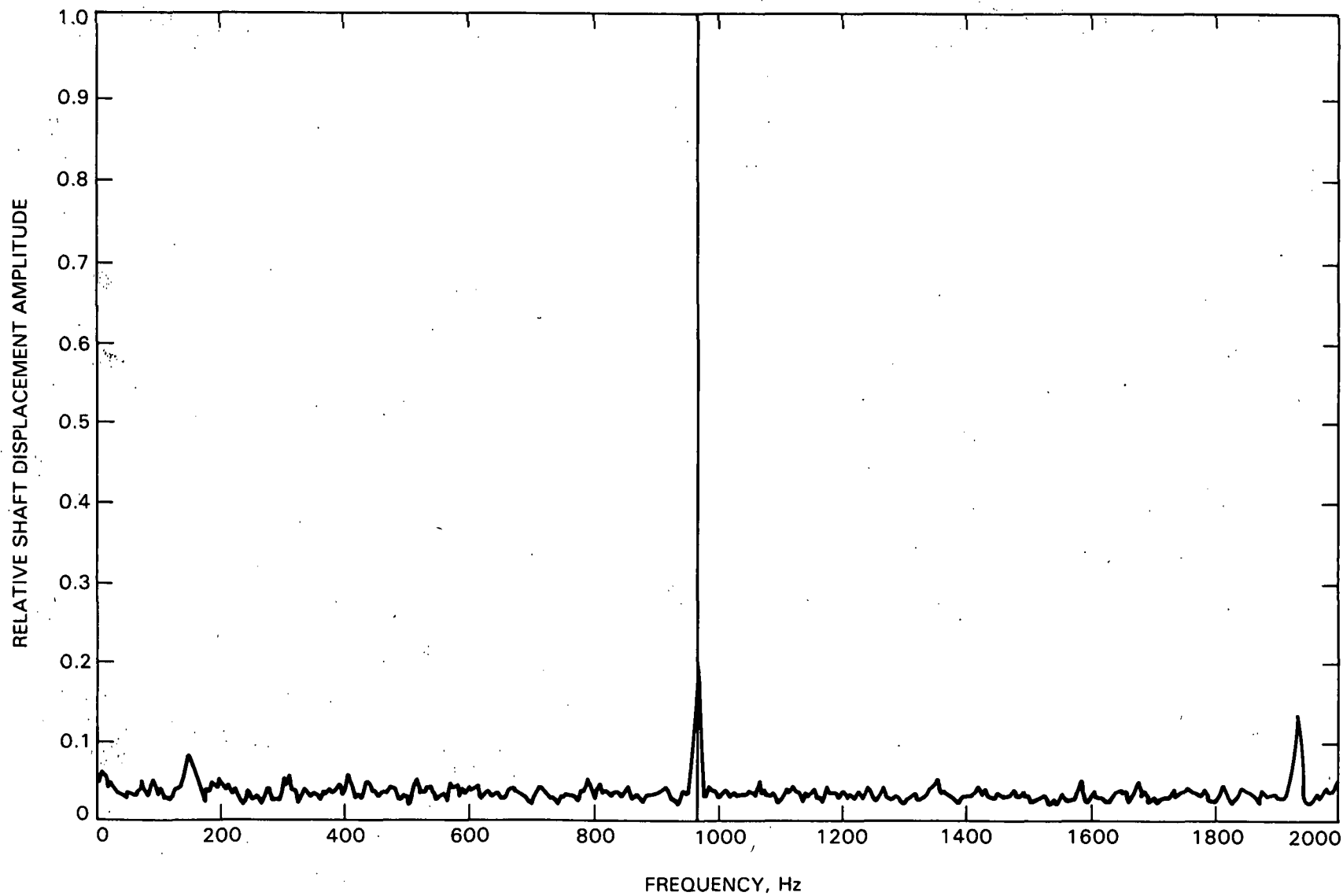

Figure 8-1. Typical Shaft Displacement Spectrum of Waukesha Five-Pad Bearing at 90 deg on October 19, 1983 (Pump End "Y" Probe, TAP Build 38).

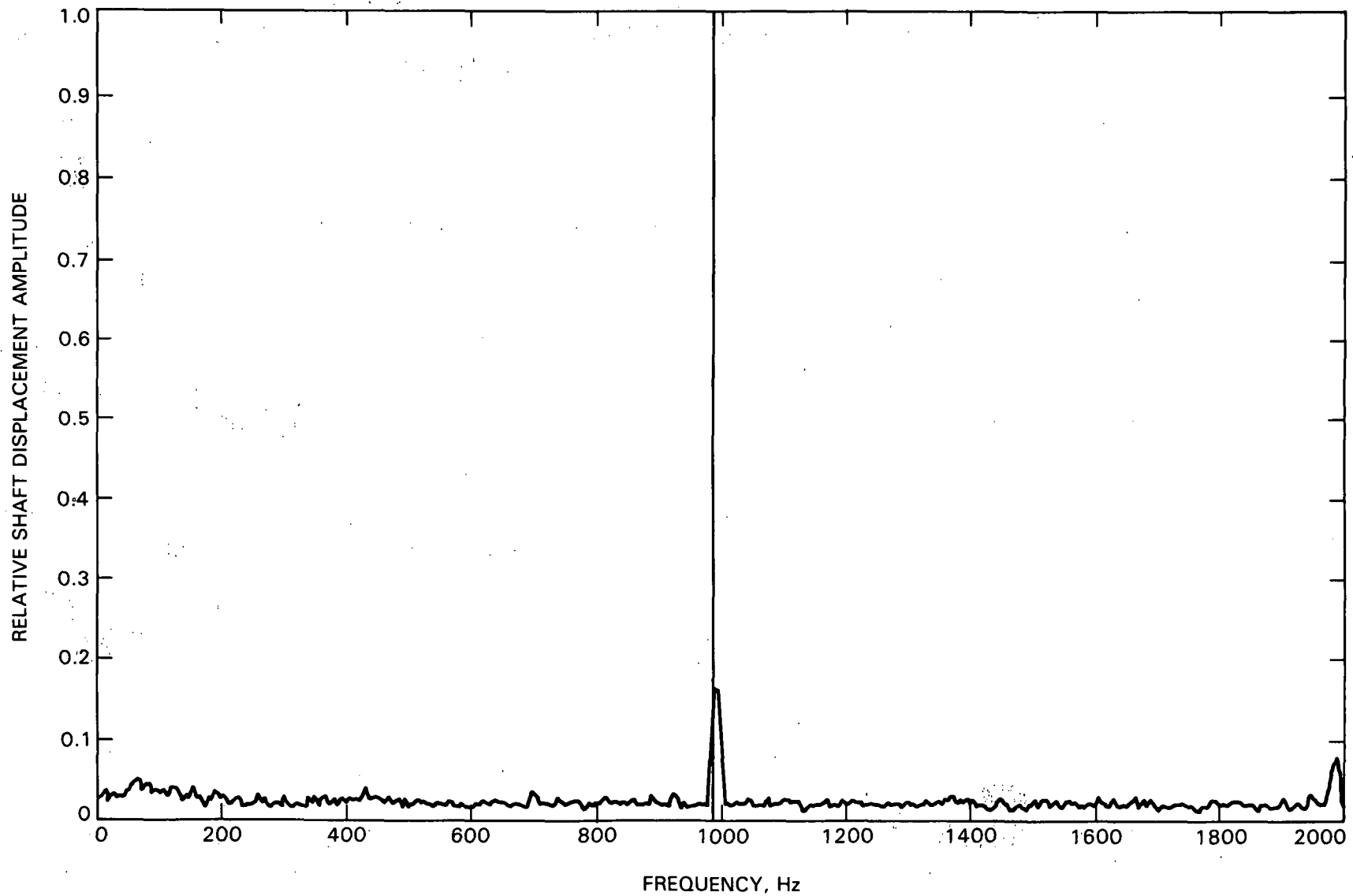

Figure 8-2. Typical Shaft Displacement Spectrum of Waukesha Five-Pad Bearing at 5 deg on October 29, 1983 (Pump End "X" Probe, TAP Build 39)

SECTION IX

CONCLUSIONS

The Small Community Solar Thermal Power Experiment (SCSE) organic Rankine-cycle (ORC) turbine/alternator/pump (TAP) readiness review board assembled by DOE determined that the engine was ready for field testing at Osage City, Kansas, because of the success of the 100-h test. The project was then assigned to Sandia National Laboratories, Albuquerque, New Mexico, where an additional 200 h of testing was accumulated without failure. A complete set of engine drawings was delivered to JPL, and all hardware was sent to Sandia. Unfortunately, the computer control system for the engine that performed so successfully at the Parabolic Dish Test Site was not used by Sandia, nor was the Nova-supplied inverter repaired and used.

The rotor bearing problems experienced in this high-speed, toluene-lubricated bearing high-power density engine development program resulted from combined rotordynamic instability and electrical dynamic discharge across the bearing surfaces. The rotordynamic instability was observed to varying degrees in all TAP builds with the lubricant flowing down the center line of the shaft and discharging fluid radially out onto the bearing surfaces. This instability phenomenon is easily seen when shaft proximity probe amplitude versus frequency plots are compared for TAP build 14 (Figure 9-1) and TAP builds 38 and 39 (see Figures 8-1 and 8-2). All three of these figures are on directly comparable amplitude scales, and the largest peak in Figure 9-1 represents a rotordynamic instability. Fully externally lubricated five-pad tilting-pad journal bearings, a Rayleigh step turbine end, and a Fogg flat pad pump end thrust bearing were included in the final design. The effects of the electrical discharge across the bearing surfaces are readily observable even after the rotordynamic instability was corrected (see Figures 7-11 and 7-12). The solution to the electrical discharge problem was to mount all bearings onto an electrically insulated bearing carrier. This design interrupted the electrodynamic circuit through the PMA stator, bearings, and shaft and forced all stray currents to flow through their respective grounding straps.

This program culminated with the successful demonstration and test of a high-temperature 400°C (750°F) air-cooled toluene Rankine-cycle engine hermetically sealed with a PMA. This high-speed (60,000 rev/min) engine was capable of delivering 25 kWe at a 21 to 23% thermal-to-electric efficiency in a relatively compact configuration (1-m diameter by 1.5-m length) with a mass of less than 396 kg.

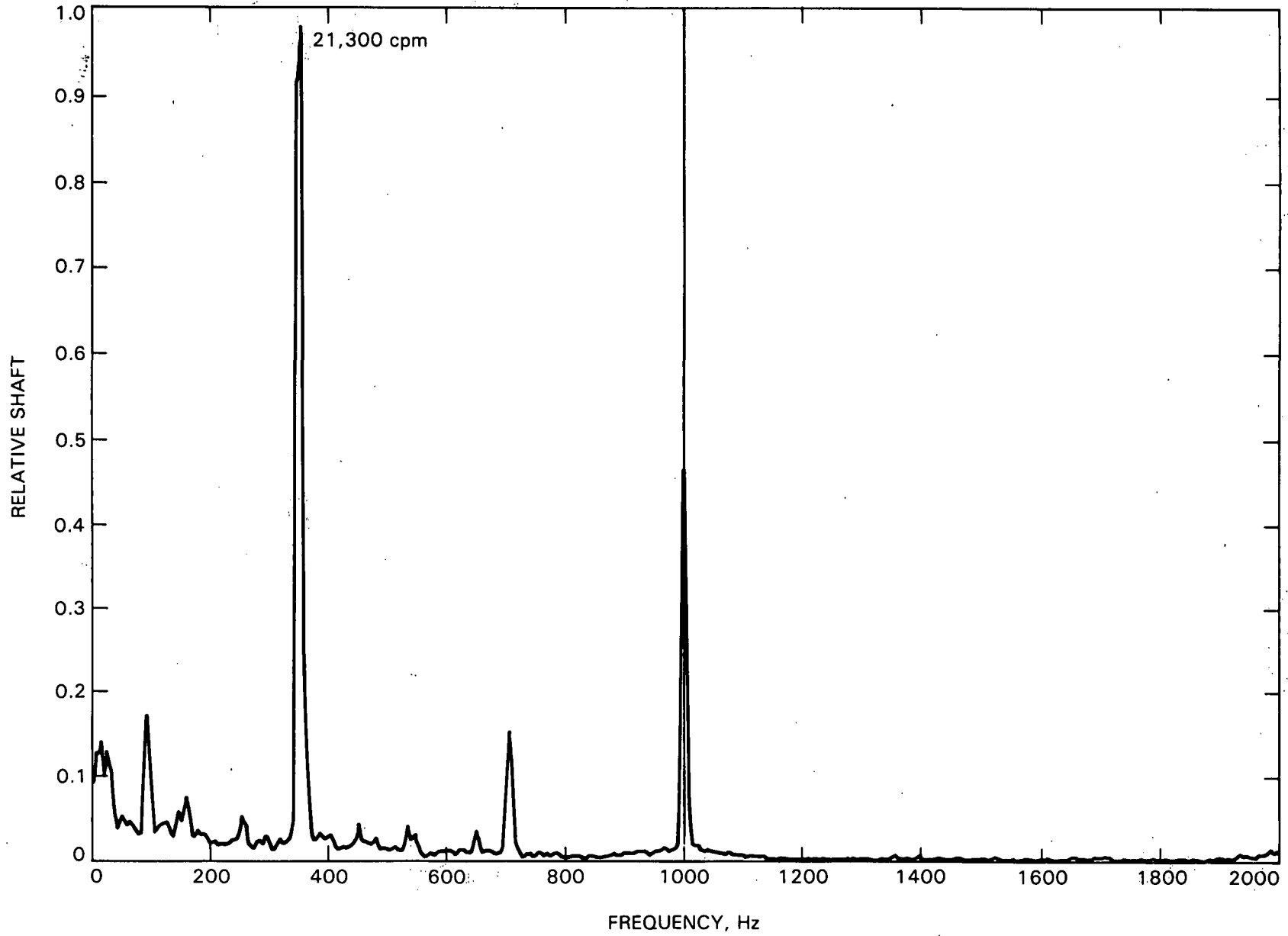

Figure 9-1. Typical Shaft Displacement Spectrum of Barber-Nichols Three-Pad Bearings, December 1982 (Turbine End "Y" Probe, TAP Build 14)

SECTION X

REFERENCES

- 1-1. Kiceniuk, T., Development of an Organic Rankine-Cycle Power Module for a Small Community Solar Thermal Power Experiment, JPL Publication 85-3, DOE/JPL-1060-80, Jet Propulsion Laboratory, Pasadena, California, January 15, 1985.
- 1-2. Clark, T. B., Test Results of an Organic Rankine-Cycle Power Module for a Small Community Solar Thermal Power Experiment, JPL 9950-995, DOE/JPL-1060-83, prepared for Jet Propulsion Laboratory by Ford Aerospace and Communications Corporation, Newport Beach, California, January 15, 1985.
- 7-1. Lewis, A., Failure Analysis Report CTS 0440R of 44962 Turbo Alternator, FACC, FAR No. CTS 0440R, Ford Aerospace and Communications Corporation, Newport Beach, California, March 30, 1983.
- 8-1. Elliott, T. J., Preliminary Final Report 100-hour PCS Test: Bearing Demonstration, Barber-Nichols Engineering Company, Arvada, Colorado, December 19, 1983.

1. Report No. 85-81	2. Government Accession No.	3. Recipient's Catalog No.	
4. Title and Subtitle Bearing Development Program for a 25-kWe Solar-Powered Organic Rankine-Cycle Engine		5. Report Date September 15, 1985	6. Performing Organization Code
7. Author(s) B. Nesmith		8. Performing Organization Report No.	
9. Performing Organization Name and Address JET PROPULSION LABORATORY California Institute of Technology 4800 Oak Grove Drive Pasadena, California 91109 JFS7450		10. Work Unit No.	11. Contract or Grant No. NAS7-918
12. Sponsoring Agency Name and Address NATIONAL AERONAUTICS AND SPACE ADMINISTRATION Washington, D.C. 20546		13. Type of Report and Period Covered JPL Publication	
15. Supplementary Notes Sponsored by the U.S. Department of Energy through Interagency Agreement DE-AM04-80A113137 with NASA; also identified as DOE/JPL 1060-92 and as JPL Project No. 5105-146 (RTOP or Customer Code 776-81-62).		14. Sponsoring Agency Code	
<p>16. Abstract</p> <p><i>(A)</i> This report summarizes ^{is summarized} The bearing development program for a 25-kWe power conversion subsystem (PCS) consisting of an organic Rankine-cycle engine, permanent magnet alternator (PMA) and rectifier to be used in a 100-kWe point-focusing distributed receiver solar power plant. The engine and alternator were hermetically sealed and used toluene as the working fluid. The turbine, alternator, and feed pump (TAP) were mounted on a single shaft operating at speeds up to 60,000 rev/min. Net thermal-to-electric efficiencies in the range of 21 to 23% were demonstrated at the maximum working fluid temperature of 400°C (750°F).</p> <p>A chronological summary of the bearing development program is presented. The primary causes of bearing wear problems were traced to a combination of rotordynamic instability and electrodynamic discharge across the bearing surfaces caused by recirculating currents from the PMA. These problems were resolved by implementing an externally supplied, flooded-bearing lubrication system and by electrically insulating all bearings from the TAP housing. This program resulted in the successful development of a stable, high-speed, toluene-lubricated five-pad tilting-pad journal bearing and Rayleigh step thrust bearing system capable of operating at all inclinations between horizontal and vertical.</p> <p><i>@ABA: Author</i></p>			
17. Key Words (Selected by Author(s)) Power Sources Systems Analysis		18. Distribution Statement Unclassified-Unlimited	
19. Security Classif. (of this report) Unclassified	20. Security Classif. (of this page) Unclassified	21. No. of Pages 74	22. Price