

NASA CR-175, 108  
N86-28729

NASA-CR-175108  
19860019257

CR 175108  
R86AEB267

# 1700° C OPTICAL TEMPERATURE SENSOR

Final Report  
July 1986

Contract No. NAS3-24085

Prepared for

R.J. Baumbick  
NASA-Lewis Research Center  
Cleveland, Ohio 44135

JUL 14 1987  
LANGLEY RESEARCH CENTER  
LIBRARY, NASA  
HAMPTON, VIRGINIA

By

P.W. Mossey, Principal Investigator  
W.M. Shaffernocker, Project Manager  
A.R. Mulukutla, Program Administrator



Aircraft Engine Business Group  
Advanced Technology Programs Dept.  
Cincinnati, Ohio 45215

Trade names or manufacturer's names are used in this report for identification only. This usage does not constitute an official endorsement, either expressed or implied, by the National Aeronautics and Space Administration, or by the General Electric Company.

1. Report No. CR-175108	2. Government Accession No.	3. Recipient's Catalog No.	
4. Title and Subtitle  1700° C Optical Temperature Sensor		5. Report Date March 1986	6. Performing Organization Code
		8. Performing Organization Report No. R86AEB267	
7. Author(s) P.W. Mossey		10. Work Unit No.	
9. Performing Organization Name and Address General Electric Company Aircraft Engine Business Group 1 Neumann Way Cincinnati, OH 45215		11. Contract or Grant No. NAS3-24085	
		13. Type of Report and Period Covered Final Report Sep. 1983 to Feb. 1986	
12. Sponsoring Agency Name and Address NASA-Lewis Research Center 21000 Brookpark Road Cleveland, OH 44135		14. Sponsoring Agency Code	
		15. Supplementary Notes	
16. Abstract  A new gas temperature sensor was developed that shows promise of sufficient ruggedness to be useful as a gas turbine temperature sensor. The sensor is in the form of a single-crystal aluminum oxide ceramic, ground to a cone shape and given an emissive coating. A lens and an optical fiber conduct the thermally emitted light to a remote and near-infrared photodetector assembly. Being optically coupled and passive, the sensor is highly immune to all types of electrical interference. Candidate sensors were analyzed for optical sensor performance, heat transfer characteristics, stress from gas loading. This led to the selection of the conical shape as the most promising for the gas turbine environment. One uncoated and two coated sensing elements were prepared for testing. Testing was conducted to an indicated 1750° C in a propane-air flame. Comparison with the referee optical pyrometer shows an accuracy of $\pm 25^\circ$ C at 1700° C for this initial development. One hundred cycles from temperature to 1700° C left the sapphire cone intact, but some loss of the platinum, 6% rhodium coating was observed. Several areas for improving the overall performance and durability are identified.			
17. Key Words (Suggested by Author(s)) Gas temperature sensor Optical sensor Turbine inlet temperature Fiber optics Gas turbine instrumentation		18. Distribution Statement	
19. Security Classif. (of this report)	20. Security Classif. (of this page)	21. No. of Pages	22. Price*

\* For sale by the National Technical Information Service, Springfield, Virginia 22161

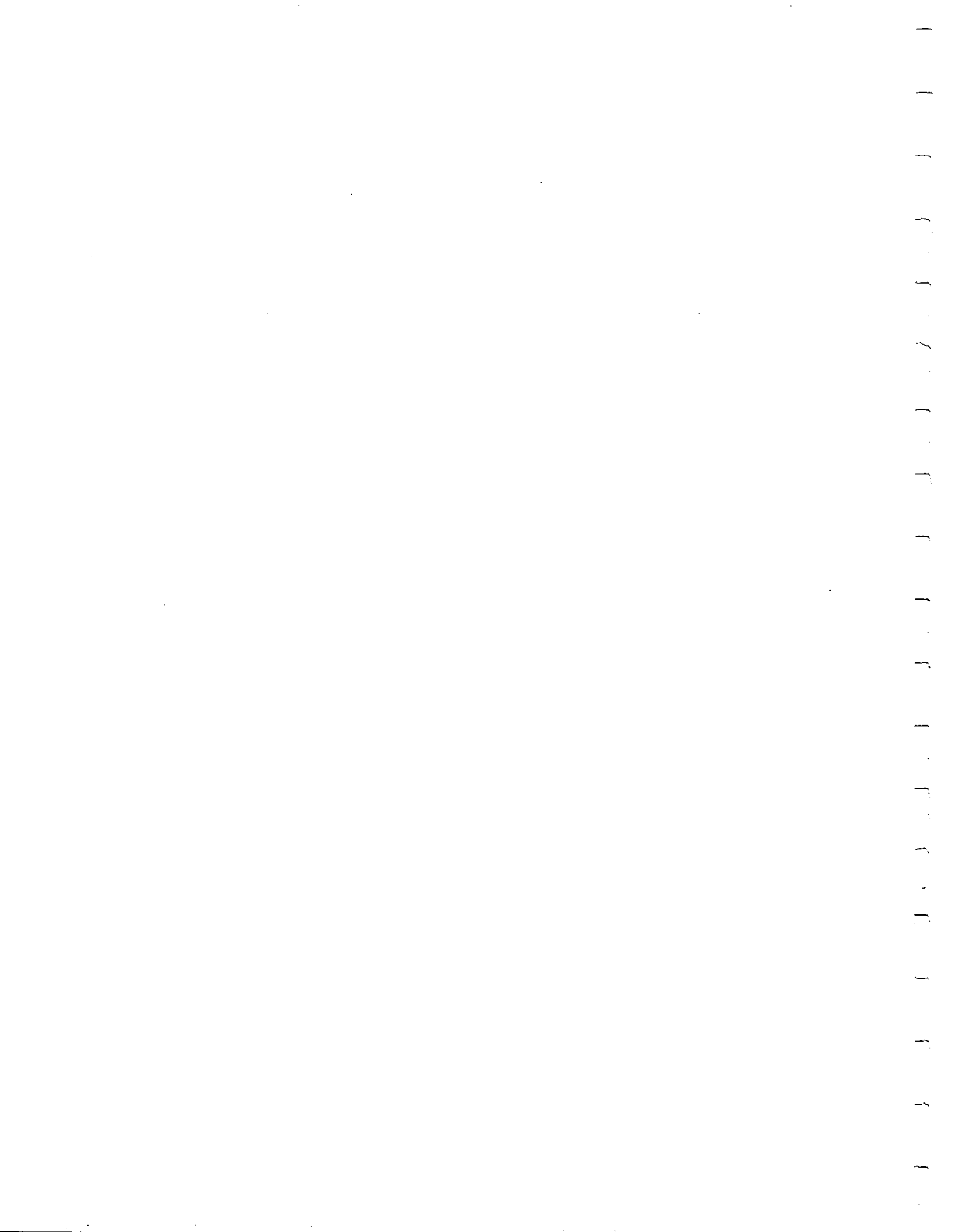

## TABLE OF CONTENTS

<u>Section</u>		<u>Page</u>
1.0	SUMMARY	1
2.0	INTRODUCTION	1
3.0	PRELIMINARY DESIGN	2
	3.1 Brainstorm Session	2
	3.2 Literature Search	2
	3.3 Evaluation Criteria	2
	3.4 Vendor Evaluation Criteria and Expert Contacts	5
	3.5 Analytical Studies	6
	3.6 Lab Tests	14
	3.7 Evaluation of Candidate Techniques	14
	3.8 Selection of Candidate Pyrometer	24
4.0	DESIGN AND FABRICATION	29
	4.1 Sensor Structural Integrity and Optical Properties	29
	4.1.1 Cylindrical Sensor	29
	4.1.2 Conical Sensor	29
	4.1.3 Preferred Design	29
	4.2 Sensor Holder	30
	4.2.1 Thermal	30
	4.2.2 Optical, Fiber Optic, and Connectors	30
	4.3 Electronics	30
	4.3.1 Detector	35
	4.3.2 Amplifiers	37
	4.3.3 Analog to Digital Converter	37
	4.3.4 Computer, Display, and Printer	37
	4.3.5 Computer Programs	38
5.0	CALIBRATIONS	39
	5.1 Spectral Response Calibrations	40
	5.2 Precision Radiometric Calibrations	40
6.0	TESTING	40
	6.1 Flame Powered Cavity Furnace	40
	6.2 Vacuum Aspirated Furnace	40
	6.3 Sensor and Coating Integrity Tests	40
	6.4 Summary of Tests	47
7.0	RESULTS AND EVALUATION	52
8.0	DISCUSSION	55

TABLE OF CONTENTS (Concluded)

<u>Section</u>	<u>Page</u>
9.0 RECOMMENDATIONS	57
9.1 Sensor	57
9.2 Fiber Optic	59
9.3 Detector Package	59
10.0 REFERENCES	60
APPENDIX A - Brainstorm Session For New Sensor Ideas	62
APPENDIX B - Key Word List - Optical Gas Temperature Sensor	65
APPENDIX C - Annotated Bibliography	66
APPENDIX D - Computer Programs	71
APPENDIX E - Sensor Structural and Optical Analysis: Cylindrical Versus Conical	142
APPENDIX F - Mechanical Detail of Sensor Assembly	148
APPENDIX G - Electronic Diagrams and Component and Panel Layout	149
APPENDIX H - Photocurrent Calculations	155
APPENDIX I - Operating Instructions	156
APPENDIX J - Scanning Electron Micrographs	157

## LIST OF ILLUSTRATIONS

<u>Figure</u>		<u>Page</u>
1.	Preliminary Design Outline.	3
2.	Heat Transfer to Temperature-Sensing Object Immersed in a Gas Flow.	9
3.	Calculated Temperature Difference Between Sensing Probe and Gas Stream.	10
4.	Temperature Sensor in Typical Gas Turbine Combustor Showing View Angles.	11
5.	Calculated Temperature Difference Between Sensing Probe and Gas Stream, Versus Gas Temperature.	13
6.	Gas Band Radiation Pyrometer and Particle Radiation Pyrometer.	15
7.	Hot Target Aspirated Ceramic Pyrometer.	18
8.	Hot Target Unshielded Metal Pyrometer.	19
9.	Sapphire Crystal Thermometer.	21
10.	Protected Iridium-Tipped Light Pipe.	22
11.	A Shielded Gas Temperature Measuring Probe and System.	23
12.	Optical Gas Temperature Sensor and Holder Assembly.	31
13.	Photo of the Sensor Assembly with Uncoated Cone Next to Uninstalled Coated Cone.	33
14.	1700° C Gas Temperature System-Electronics Block Diagram.	34
15.	Spectral Response Calibration.	41
16.	Precision Radiometric Calibration.	42
17.	Photo of Precision Radiometric Calibration.	43
18.	Flame Heated Cavity Furnace Test Arrangement.	45
19.	Vacuum Aspirated Furnace.	46
20.	Coating Integrity Test Configuration.	48
21.	Sputter Coating of Two Sapphire Cones.	50
22.	Hollow Refractory Material Cone for Use as a Sensing Element.	58

LIST OF ILLUSTRATIONS (Concluded)

<u>Figure</u>		<u>Page</u>
E-1.	Cylindrical Sensor.	145
E-2.	Conical Sensor.	145
E-3.	Conical Sensor Operation.	147
F-1.	Optical Gas Temperature Sensor and Holder Assembly.	148
G-1.	Front Panel Layout.	150
G-2.	Rear Panel Layout.	150
G-3.	Component Layout.	151
G-4.	Schematic Diagram of 1700° C Gas Temperature Sensor.	153
J-1.	Cone Element No. 1 Tip.	158
J-2.	Cone Element No. 1 Tip.	158
J-3.	Cone Element No. 3 Tip.	159
J-4.	Cone Element No. 3 Tip.	159
J-5.	Cone Element No. 3 Side.	160
J-6.	Cone Element No. 3 Side.	160



## LIST OF TABLES

<u>Table</u>		<u>Page</u>
1.	Evaluation Criteria - Parameter Value.	4
2.	Evaluation Criteria - Candidate Techniques Rating.	5
3.	Environmental Parameters for Figures 1 and 2.	12
4.	Parameters Used at Two Throttle Extremes for Calculating Temperature Difference Between Probe and Gas Stream.	12
5.	1700° C Optical Gas Temperature Sensor Candidate Evaluation Chart - First Version.	25
6.	1700° C Optical Gas Temperature Sensor Candidate Evaluation Chart - Second Version.	26
7.	1700° C Optical Gas Temperature Sensor Candidate Evaluation Chart - Third Version.	27
8.	1700° C Optical Gas Temperature Sensor Candidate Evaluation Chart - Fourth Version.	28
9.	Sensor and Holder Parts, Description and Specification.	32
10.	Electronics for 1700° C Temperature Sensor.	36
11.	Test Summary Chart.	49
12.	Test and Evaluation Results.	53
13.	Constant Input Data.	54
14.	Gas Temperature Calculations.	54
E-1.	Stresses in a Cylindrical Sensing Element Due to Gas Flow Loading.	143
H-1.	Photocurrent and Ratio Versus Temperature.	155

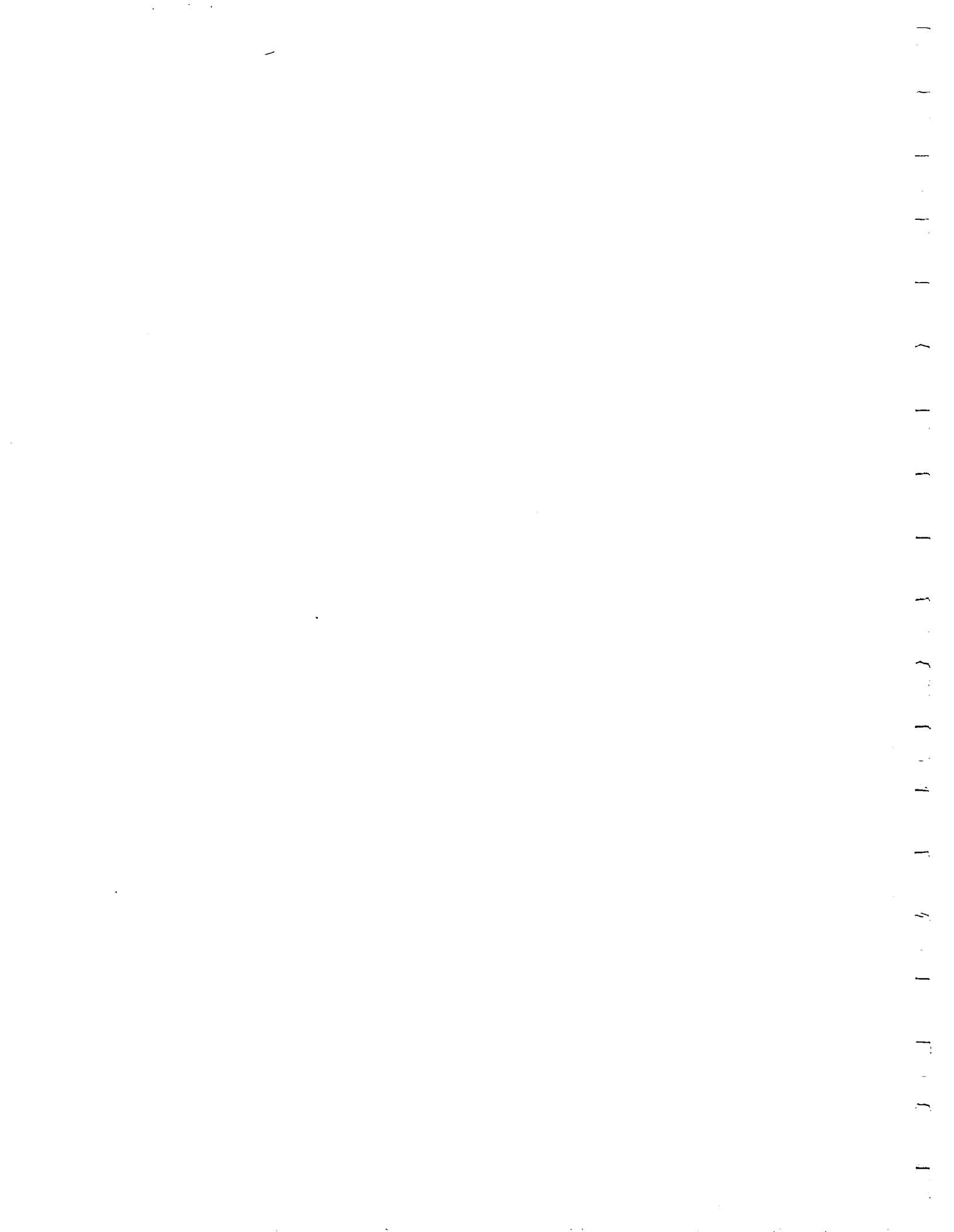

## 1.0 SUMMARY

A new gas temperature sensor was developed that shows promise of sufficient ruggedness to be useful as a gas turbine temperature sensor. The sensor is in the form of a single crystal aluminum oxide ceramic, ground to a cone shape, and given an emission coating. A lens and an optical fiber conduct the thermally emitted light to a remote, near-infrared, photodetector assembly. Being optically coupled and passive, the sensor is highly immune to all types of electrical interference. Candidate sensors were analyzed for optical sensor performance, heat transfer characteristics and stress from gas loading. This led to the selection of the conical shape as the most promising for the gas turbine environment. One uncoated, and two coated, sensing elements were prepared for testing. Testing was conducted to an indicated 1750° C in a propane-air flame. Comparison with the referee optical pyrometer shows an accuracy of  $\pm 25^\circ$  C at 1700° C for this initial development. One hundred cycles from room temperature to 1700° C left the sapphire cone intact, but some loss of the platinum 6% rhodium coating was observed. Several areas for improving the overall performance and durability are identified.

## 2.0 INTRODUCTION

Current gas temperature measurements in the hot flowpath of gas turbine engines has been limited by material properties and cooling techniques to approximately 1300° C. Recent advances in optical methods and refractory materials showed strong promise for extension of this temperature limit of the sensor itself. The use of fiber optic coupling was encouraged to provide the system with greatly improved immunity to electrical interference from nearby lightning strikes, radar pulses, and other noise sources.

The program was planned to design, fabricate, and test an optical temperature sensor capable of measuring gas temperatures to an upper limit goal of 1700° C. The program was carried out in four tasks:

- Task I - Preliminary Design
- Task II - Design and Fabrication
- Task III - Testing
- Task IV - Reporting

### 3.0 PRELIMINARY DESIGN

The various elements that made up this first task are shown graphically in Figure 1, "Preliminary Design Outline."

#### 3.1 BRAINSTORM SESSION

A technical meeting was held to "brainstorm" various configurations and techniques to measure gas temperatures to 1700° C in a gas turbine engine. This resulted in the generation of additional sensor and configuration concepts beyond that described in the proposal. See Appendix A, "Brainstorm Session for New Sensor Ideas."

A second result of this meeting was a list of key words and phrases that were used for an engineering literature search and for inquiries to vendors. See Appendix B, "Key Word List - Optical Gas Temperature Sensor."

#### 3.2 LITERATURE SEARCH

From a review of approximately 700 abstracts, approximately 40 full reports and several patents were ordered and studied. The abstracts of the more important items are included, along with comments and criticism, as Appendix C, "Annotated Bibliography." Two subject areas are included: Gas Temperature Measurement and Refractory Materials.

#### 3.3 EVALUATION CRITERIA

A criteria was developed for the purpose of placing both a value and an importance factor on each of the goals (parameters). The candidate sensor techniques were rated on a scale from zero to four on each parameter and value.

Table 1 is the final version of the chart that was mutually worked out by the customer and contractor. Based on current and future gas turbine engine requirements, three temperature ranges were deemed of interest. Temperatures below 600° C are usually sub-idle and are of less importance than 600° to 1700° C. Future engines may use combustion discharge temperatures up to 2230° C. Although not included in the original contract goals, this elevated temperature range was included because of its future significance. In each range, the two levels of accuracy reflect both the original contract goals and a second, more realistic goal based on state-of-the-art temperature standards.

Two time responses are listed. Parameter 13 is a control system figure based on usual turbine discharge thermocouple characteristics. Parameter 14 is a much faster (0.2 seconds) response goal that could be used for an engine stall evasion and recovery control loop. On other parameters on the chart,

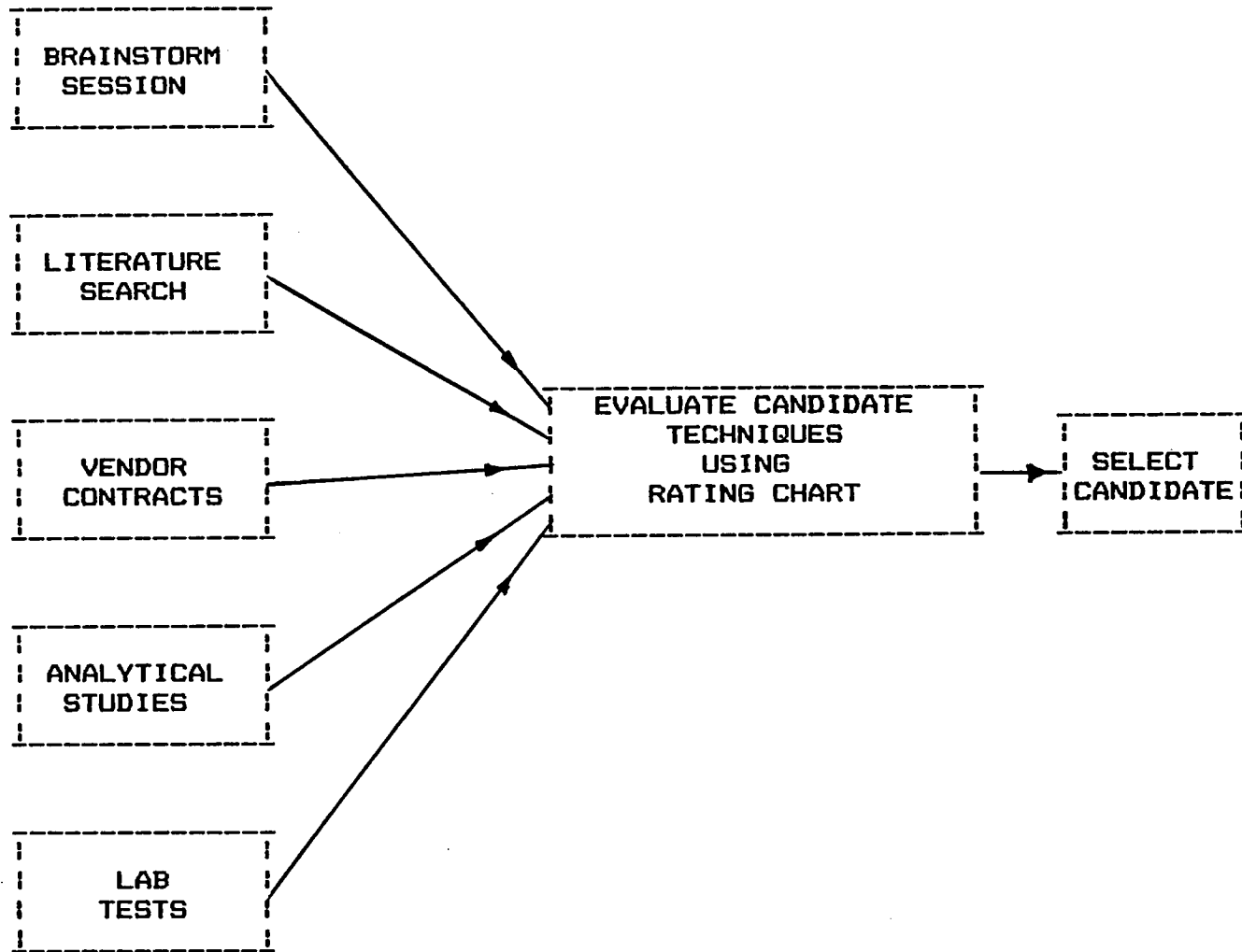

Figure 1. Preliminary Design Outline.

Table 1. Evaluation Criteria - Parameter Value.

<u>No.</u>	<u>Parameter</u>	<u>Value</u>	<u>Importance:</u> <u>Highest = 10</u> <u>Lowest = 0</u>
1	Temperature Range, Subidle	170° to 600° C	5
2	Accuracy	± 1° C	5
3		± 10° C	5
4	Temperature Range, Idle to	600° to 1700° C	10
5	Full Power	± 1° C	7
6	Accuracy	± 2° C	10
7	Temperature Range, Future	1700° to 2230° C	5
8	Engines	± 3° C	6
9	Accuracy	± 10° C	5
10	Resolution	± 1° C	10
	Linearity*		
	Repeatability*		
	Hysteresis*		
11	Environment: Oxidizing,	Mach No. 0.5	6
12	Oxidizing 25 Atmos.	Mach No. 0.2	10
13	Time Response 3 Sec. for 63% of Step Changes		10
14	0.2 Sec. for 63% Step Change (Stall evasion/recovery)		8
15	Endurance: 100 cycles RT to 1700° C		10
16	Installed Life	30,000 hours	5
17		1,000 hours	10
18	Source/Detector & Elec.	Room Temp.	10
19		-54 to 121° C	5
20	Induced Engine Losses	0.05% Maximum	6
21	Low Risk to Engine (Foreign Object Damage)		8
22	Vibration Endurance		6
23	Low Installed Cost		4
24	Low Operating Cost		4

\* Each of these items is included under the "umbrella" of Accuracy and will not be separately rated.

two or more value listings represent either a different engine application or a contrast between the ideal and the practical application of the gas temperature sensor.

Table 2 was applied to each of the sensor candidates and for each parameter and value. To be considered a candidate optical gas temperature sensor, the technique had to use a fiber optic cable(s), with connectors, for signal and power transmission.

Table 2. Evaluation Criteria - Candidate Techniques Rating.

<u>How Well Are Parameter and Value Satisfied?</u>	<u>Rating</u>
Full Satisfied (Excellent)	4
Satisfies Over Most of Range (Very Good)	3
Comes Fairly Close to Value (Good)	2
Barely Useful (Marginal)	1
Cannot Come Usefully Close (Poor)	0

The candidates' final score was based on the sum of the products of the value and the rating. This is more fully explained in the section titled "Evaluation of Candidate Techniques."

### 3.4 VENDOR EVALUATION CRITERIA-AND EXPERT CONTACTS

The companies in the sensor market were reviewed. One company (Mikron Instrument Company) markets a fiber optic coupled radiation pyrometer, intended for surface temperature measurement in protected areas. Another company (Luxtron Company) sells a fiber sensor system that uses a phosphor coating on the tip of the optical fiber. The upper temperature limit is 200° C. Finally, Dr. Ray Dils was just launching the Accufiber Company to manufacture and sell the optical fiber thermometer product that he developed while at NBS.

Dr. Kenneth Kreider and Dr. Martin Reilly at the National Bureau of Standards were contacted. Dr. Kreider was continuing the work on development of the sapphire crystal thermometer to two areas: molten metal temperature determination (by immersion) and surface temperature measurement by direct contact to the surface.

Dr. Reilly was investigating the sapphire crystal thermometer for use as a replacement for the platinum thermometer as used in precision melting point furnaces.

Helpful literature was received from Dr. Warshawsky of the NASA Lewis Research Center on the physics of gas temperature measurement.

Several sources were helpful in the collection of single crystal aluminum oxide (sapphire) properties. Mr. Peter Warren of the Electronic Materials Division of the Union Carbide Corporation supplied a very extensive set of literature and referred the writer to Professor Arthur H. Heuer of the Department of Metallurgy and Materials Science at Case Western Reserve University. Professor Heuer supplied considerable data on the high-temperature strength properties of sapphire. His recent laboratory investigations confirm the highly directional flow stress phenomena that stem from the rhombohedral structure of the crystal. This information has allowed a "worst case" stress limit to be found for a particular orientation of the crystal.

### 3.5 ANALYTICAL STUDIES

Two types of gas-temperature measurement methods have been used in the industry: those that measure gas temperature directly from a thermodynamic property and those that measure indirectly from a secondary effect such as the heating of an immersed object (thermometer). The physical and chemical effects that underlie these two types of measurements are quite different and will be briefly summarized below.

#### Direct Methods

Sodium Line Reversal - An early direct method, sodium line reversal, is still used today as a standard. The method requires a source on one side of the gas and a spectrally sensitive detector on the other side. The method offers the feature of gas-path averaging, but it requires the presence of sodium (or other alkali metal salt) in the gas (Reference 2). The method has even been used in a probe to narrow the view to a localized region in a hypersonic tunnel (References 3 and 4).

Gas Molecular Band Radiation - This method is sometimes referred to as the emission absorption technique. It estimates temperature by measuring radiation in the optically active bands of the common gases, such as CO<sub>2</sub> or H<sub>2</sub>O, which are present in combustion gas. Long-path averaging is a feature of this method (References 2, 3, and 5).

Carbon Particle Emission - This method is similar to the gas molecular band method, but is useful over a broader range of the visible/infrared spectrum. A disadvantage is that modern fuel-efficient combustors do not generate enough carbon particles. Some unique applications of this method have been developed (References 6 and 7).

Raman Scattering - Raman scattering has been demonstrated as a powerful research tool for flame diagnostics and combustor modeling. The method is suited to medium- or short-path averaging and can be tailored to microsecond transients or several seconds averaging. The equipment is expensive and delicate at the present time, and performance is limited in the presence of particulates (References 8 and 9).



Velocity of Sound - Measuring the velocity of sound has been demonstrated as a potential method of long-path, gas-temperature measurement. The hardware is fairly rugged, but accuracy is highly dependent on knowledge of the gas constituents, which will depend on the local fuel-air ratio (Reference 10).

To summarize, direct methods of gas-properties measurement involve some intrinsic property of the gas or some seeded tracer element or compound in the gas. The advantage of these methods is that no equipment must be maintained at the high gas temperature; they are truly noncontact methods. The difficulty is usually in the complex equipment needed to generate and/or detect and process the signals.

### Indirect Methods

Indirect methods involve the immersion of an object in the gas flow, attempting to cause the object to "reach" the gas-stream temperature and then measuring the temperature of the object by one of several means.

Thermocouple - These devices are widely used (References 1 and 11). In the best probe designs they are placed in a holder to provide thermodynamic conditions that reduce the object-to-gas-stream temperature difference to an acceptable value.

Other Sensors - Other devices have used properties such as thermal expansion of bimetal elements or (recently) of the Fabry-Perot cell (Reference 12), the velocity of sound waves (Reference 13), and the velocity of light in an optical fiber (Reference 14). An optical absorption technique using rare earth doped glass optical fibers has been demonstrated (Reference 14). The most accurate and reliable method, potentially, is the measurement of thermal radiation from a near-blackbody cavity. This is the technique used to interpolate and extrapolate the international temperature scale (References 15 and 16).

The advantage of indirect methods is in the relative simplicity of the hardware to acquire and process the temperature information. The difficulty (challenge) lies in two parts: first, setting up and controlling the heat-transfer conditions from gas to sensor and, second, accurately measuring the sensor (object) temperature.

Considering the first challenge, the temperature attained by an object immersed in a stream of hot gas generally is not identical with the temperature of the gas; instead, it is characteristic of a steady-state condition at which the rate of heat transfer to the object is equal to the rate of heat transfer away from the object. The steady-state difference between object and gas temperature is commonly called an "error," but actually it represents the balancing of six well-defined phenomena:

1. Heat transfer from the gas stream to the object by convection
2. Heat transfer from the object to the combustor walls or probe shield (and vice versa) by radiation
3. Heat transfer along the object by conduction
4. Conversion of kinetic energy to thermal energy at the boundary layer around the object described by the recovery factor,  $\gamma$ )
5. Heat transfer to the object by chemical reactions on the surface
6. Heat transfer from the gas stream to the object by radiation from the gas stream.

These processes are illustrated in Figure 2.

Analytical studies of the heat transfer environment of various probe configurations were made. A computer program, normally used for gas temperature thermocouple data reduction and analysis, was found to be suitable for analysis of any cylindrical probe in one of two possible orientations to the gas stream; that is, either end-on flow or sideways (crossflow).

The program calculates the difference in temperature between the gas stream and the probe tip, taking into account convective heat input and radiation gains and losses, as well as conduction loss. A complete copy of the program is included in Appendix D.

The first case selected for analysis was that of an unshielded, simple cylinder shape placed in a flowing gas stream in crossflow. The gas temperature was given as 1682.5° C. The mass flow parameter was varied. The cylinder diameter was also varied in binary steps, maintaining approximately 17 diameters of length. Figure 3 shows the probe orientation and computer results. Note that the temperature difference is dependent on both mass flow and diameter. For any given mass flow, the smaller probe "reads closer" to the true gas temperature. This is considered beneficial since the smaller diameter probe also has lower aerodynamic blockage, and it would also do less damage if it broke off during engine use. Note also that the smaller diameter probe has a smaller change in the computed temperature difference for a given change in the mass flow parameter.

Past experimenters have employed two different diameter probes, exposed to the same gas conditions, in an attempt to calculate the true gas temperature, given only the probe-indicated temperature, when the mass flow is unknown. However, with known mass flow, the need for two probes is reduced.

Figure 4 shows the probe in a cross section of a gas turbine combustor to better illustrate the radiation view factors that influence the computed temperature difference. The probe receives radiation from the very intense primary zone of the combustor, taken in this example to be at 1927° C. However, the view angle factor is only 0.05 of a sphere. Wall radiation

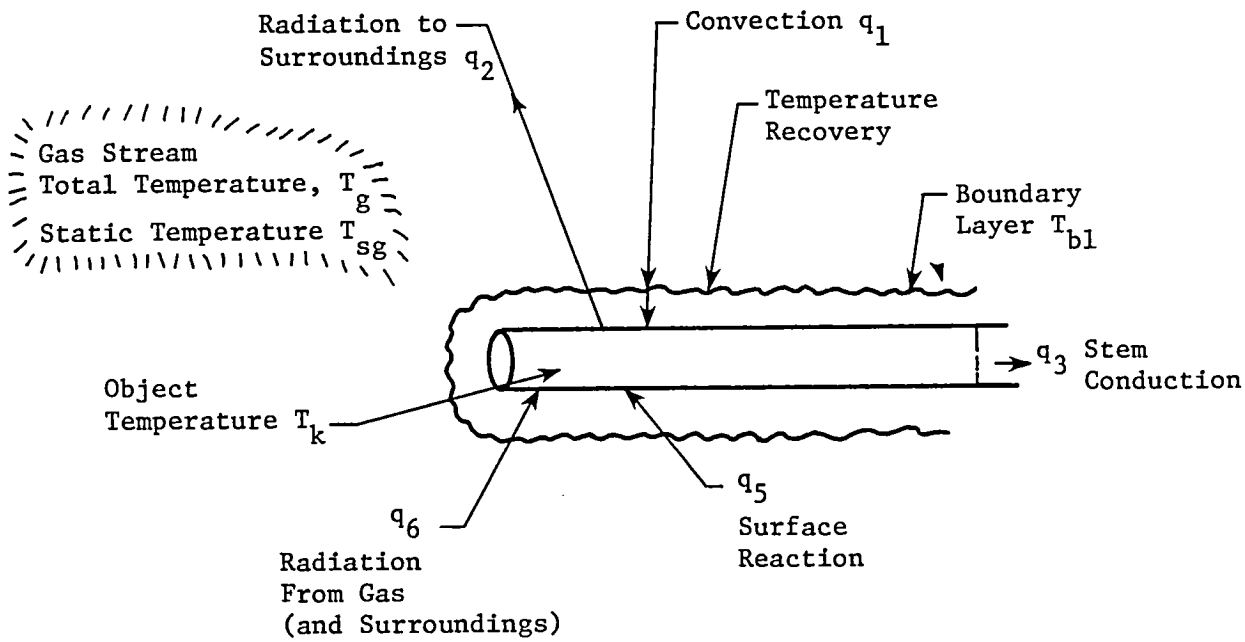

Figure 2. Heat Transfer to Temperature-Sensing Object Immersed in a Gas Flow.

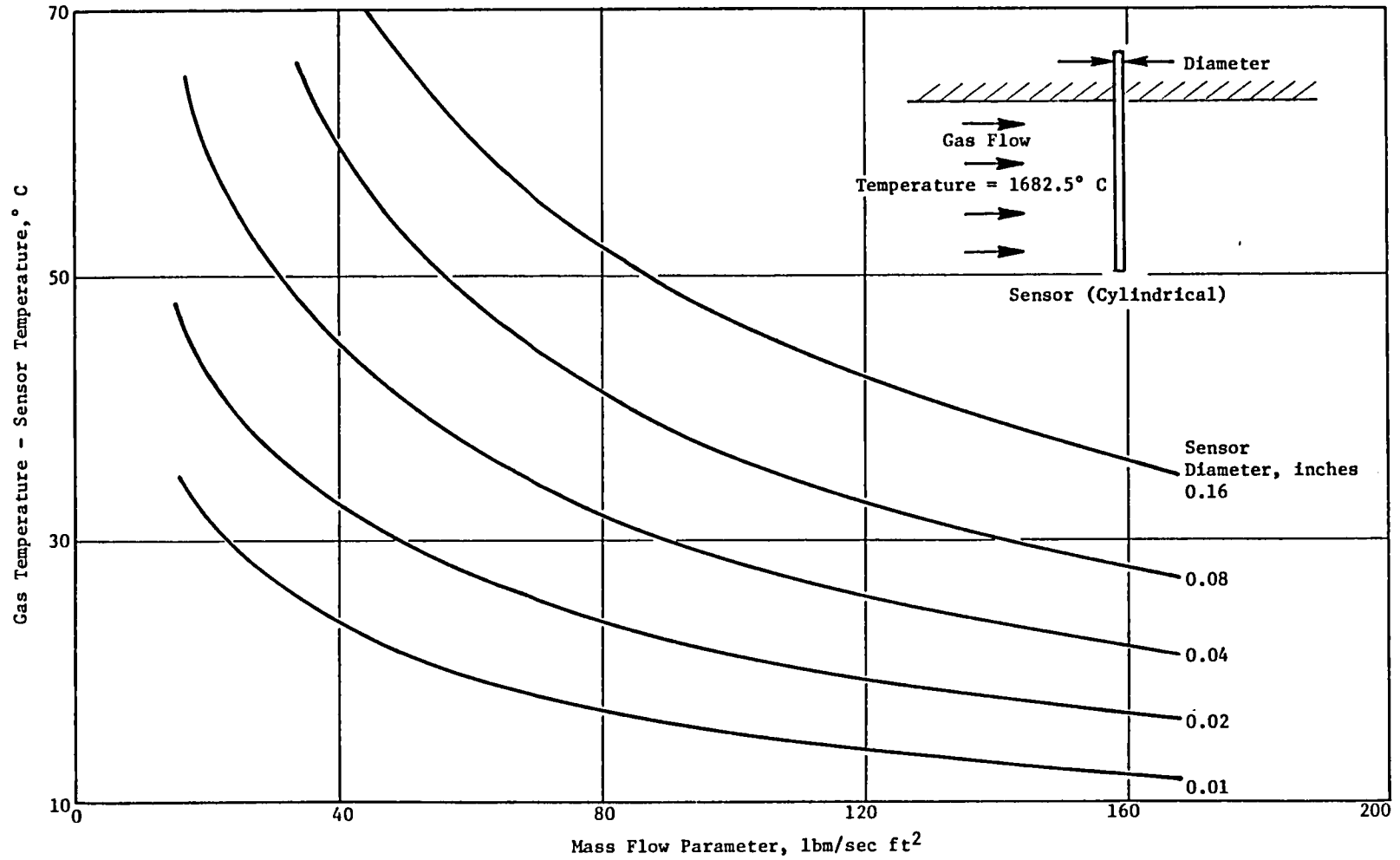

Figure 3. Calculated Temperature Difference Between Sensing Probe and Gas Stream.

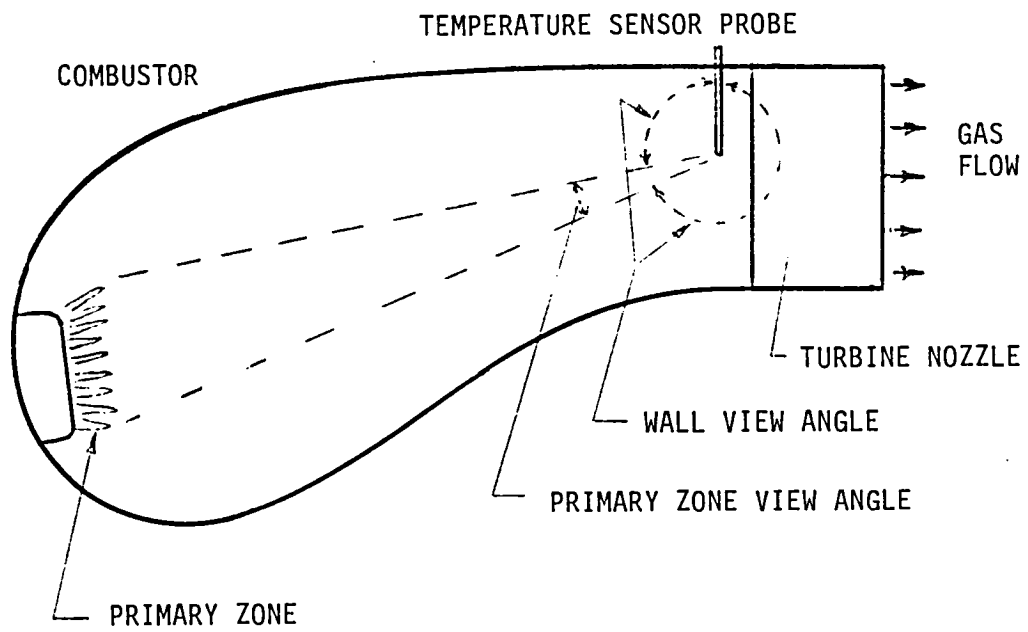

Figure 4. Temperature Sensor in Typical Gas Turbine Combustor Showing View Angles.

represents a much larger view angle factor of 0.80, but the wall temperature is assumed to be at 949° C. The wall would consist of the combustor liner and the high pressure turbine nozzle assembly. The remaining view factor of 0.15 represents the probe's view of itself; that is, the stem. This view factor has a neutral (zero) contribution of net radiation exchange. The environmental and assumed parameters are listed in Table 3.

Table 3. Environmental Parameters for Figures 1 and 2.

Gas Flow Temperature	1682.5° C
Gas Properties Used	Air Table
Primary Zone Radiation Temperature	1927° C
Probe's View Angle Factor of Primary Zone	0.05
Wall Radiation Temperature	949° C
Probe's View Angle Factor of Wall	0.80
Probe Emittance Factor	0.30
Probe Thermal Conductivity	4 Btu/hr ft° R
Calculated Temperature at	Tip

The above analysis shows clearly the effect of mass flow on the temperature difference between sensor and gas. It was also important to look at this temperature difference as a function of throttle position on a hypothetical engine. This is plotted as Figure 5, where a unique mass flow was used at each gas temperature, simulating a typical gas turbine engine cycle at throttle positions from idle to full throttle. Table 4 shows the parameters used at the two throttle extremes. At intermediate throttle settings, the gas temperature and the mass flow were each linearly interpolated

Table 4. Parameters Used at Two Throttle Extremes for Calculating Temperature Difference Between Probe and Gas Stream.

Engine Throttle Setting	Average Gas Temp ° C	Mass Flow lb/sec /Ft. <sup>2</sup>	Wall Temp. ° C	Primary Zone Temp ° C	View Factor, Primary Zone
Full	1700	169	871	1927	0.05
Idle	520	25	315	1281	0.02

It can be seen from Figure 5 that the temperature difference is a strongly nonlinear function of gas temperature.

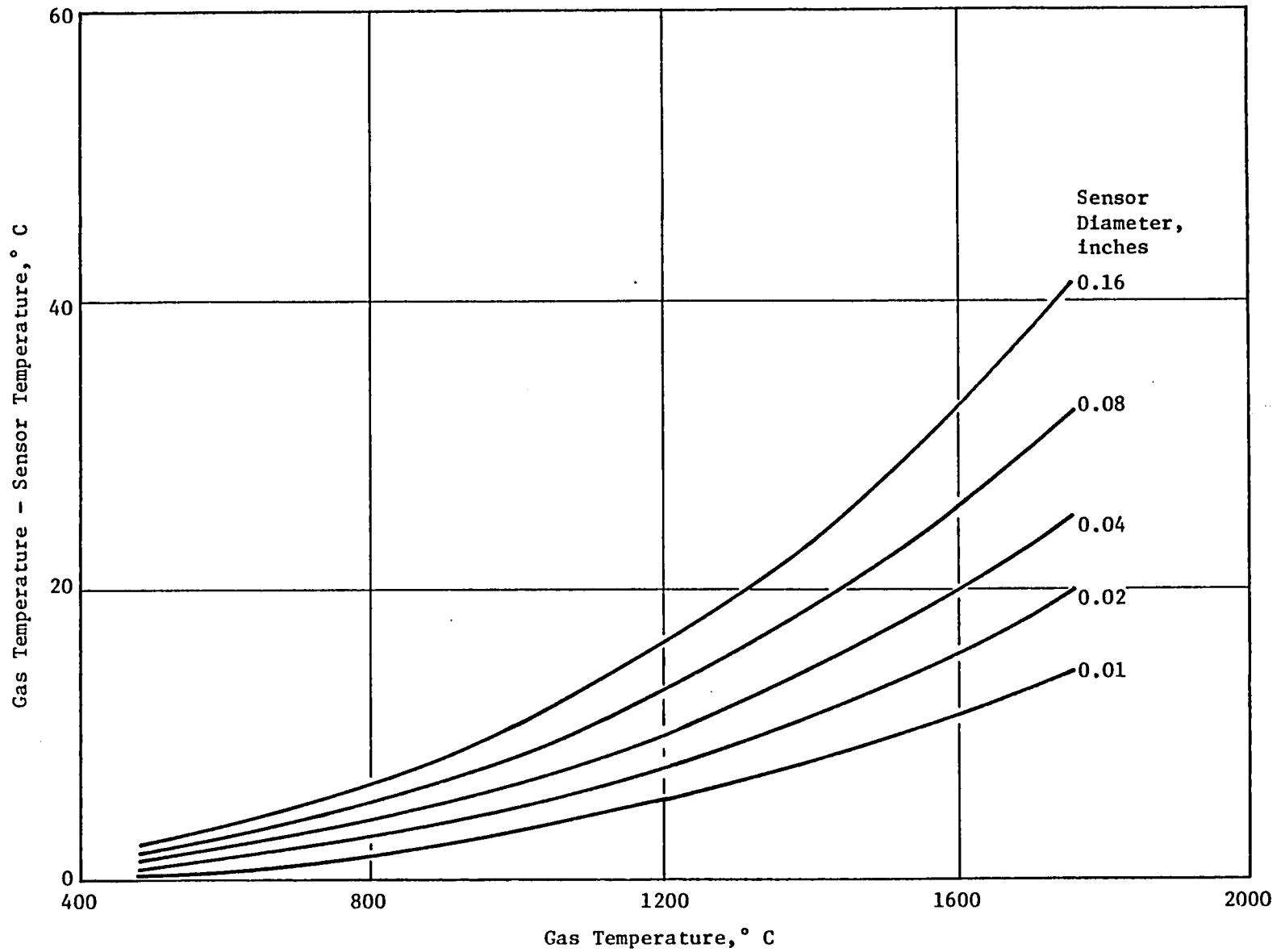

Figure 5. Calculated Temperature Difference Between Sensing Probe and Gas Stream Versus Gas Temperature.

### 3.6 LAB TESTS

No lab tests were done in Task I, Preliminary Design.

### 3.7 EVALUATION OF CANDIDATE TECHNIQUES

The Brainstorm Session, Literature Search, Vendor and Expert Contacts, and Analytical Studies were all brought together for the purpose of selecting a set of the most valuable and promising candidate temperature measurement techniques. Five candidate temperature sensors were chosen from the general field of sensors. All techniques appear to be usable with fiber optic cable for signal and power transmission.

Two of the five candidates are of the direct type, in that a temperature-related property of the gas stream is directly measured. No physical probe is immersed in the gas stream. Instead, the sensor for the two direct methods receives infrared radiation from the combustor discharge region of the engine. The two direct sensor candidates are:

- Gas Band Radiation Pyrometer
- Particle Radiation Pyrometer

Three of the five candidates are indirect types, which involves the immersion of an object in the gas flow, with the expectation that the object (probe) will "reach" the gas stream temperature. Some intrinsic property of the probe is then used to measure its temperature. For the three selected, this would be visible and/or infrared radiation. The three indirect sensor candidates are:

- Hot Target Aspirated Ceramic
- Hot Target Unshielded Metal
- Sapphire Crystal Thermometer

Each of the five candidate techniques will be discussed in detail. The first five characteristics listed under each discussion may be compared between each of the candidate techniques.

#### Gas Band Radiation Pyrometer

This gas temperature sensor uses infrared emissive radiation from the gas itself. Either the molecular CO<sub>2</sub> or H<sub>2</sub>O infrared bands are sensed. This is a direct-type sensor, in that no physical probe is immersed in the gas stream. See Figure 6. Infrared radiation is collected by the lens and focussed on a fiber optic cable. The cable conducts the energy to the Signal Processor and Display where a detector converts the energy to an electrical signal. Appropriate spectral filtering must be used in order to minimize the interfering



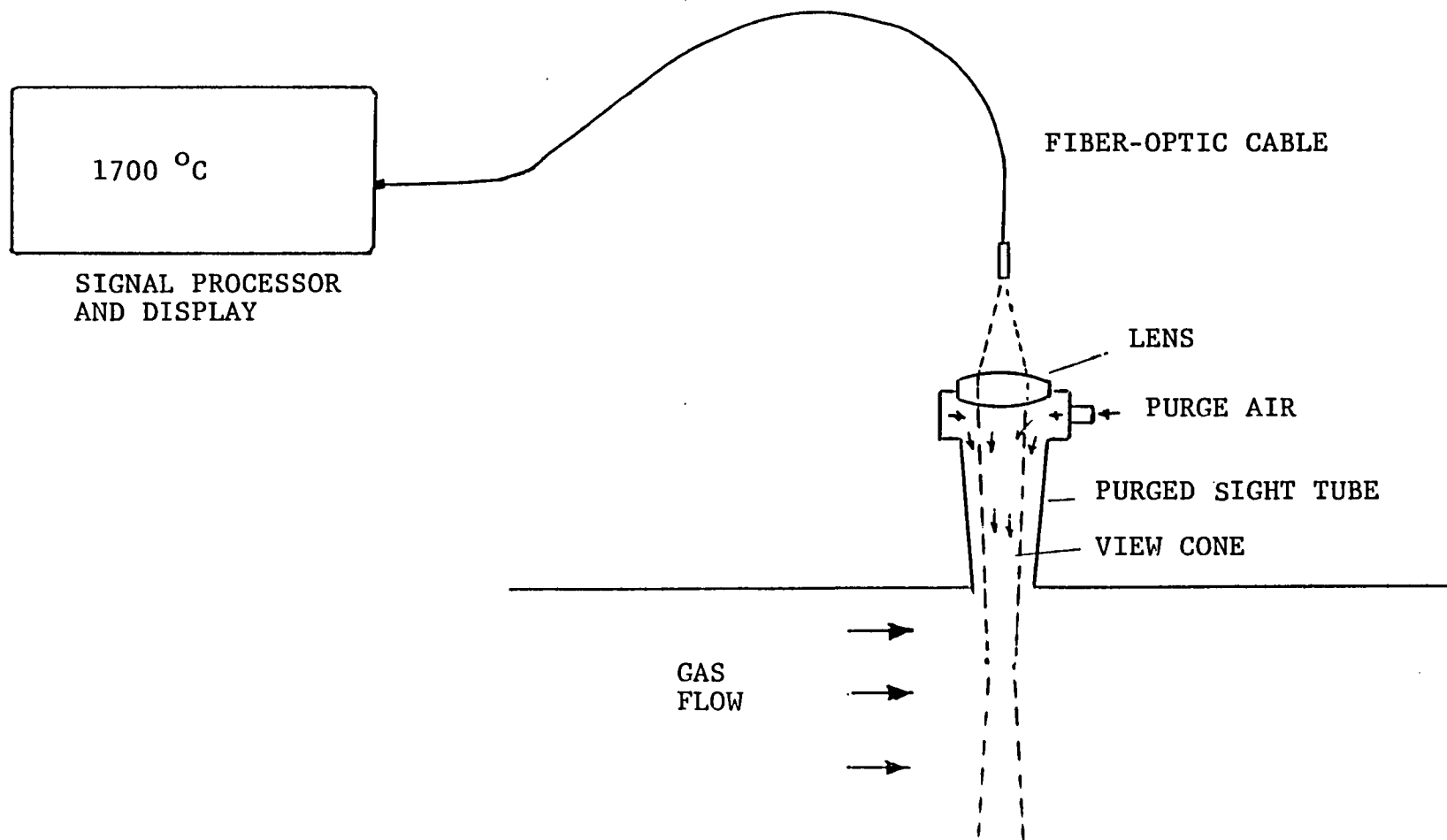

Figure 6. Gas Band Radiation Pyrometer and Particle Radiation Pyrometer.

radiation of metal engine parts. A purged sight tube is used to maintain lens cleanliness. Characteristics of the technique are:

- Direct Measurements
- Noncontact
- Uses infrared emission from CO<sub>2</sub> and H<sub>2</sub>O bands
- May be applied as a monochromatic (single-band) or as a polychromatic (two or more infrared bands) system.
- Straight path averaging characteristics, but limited by absorption.
- Background metal surfaces present problem of biasing the measurement.
- Cool boundary layer may also cause bias.
- Species concentration and pressure level will affect spectral emittance and require calibration unique to engine model and sensor installation.
- Longwave nature of infrared radiation may require a special fiber optic.

#### Particle Radiation Pyrometer

This gas temperature sensor uses infrared radiation from particles in the gas to measure gas temperature. There are two main sources of particles: externally and internally generated. The level of particles existing in the air inducted into the engine tends to vary with time and location. The internally generated particles would be carbon from the combustion process. Figure 6 shows the basic components needed: a protected lens, a fiber conduit for the collected radiation, and a signal processor and display. A potential problem in the application of this technique is the uncertainty of having sufficient particle concentration. Engine designers are improving the combustion process with a goal of eliminating particulate emissions. Characteristics of the technique are:

- Direct Measurement
- Noncontact
- Uses infrared emission of suspended particles
- Particles are small and stay close to the gas stream temperature.

- May be applied as single color or two-color technique.
- Straight path averaging characteristics, but limited at high particle concentration due to extinction.
- Hot background metal surfaces present potential problem of biasing the measurement.
- Near-infrared available spectrum allows use of current glass or silica fiber optics.
- Particle concentration may not be sufficient at all power settings to obtain an accurate measurement.

#### Hot Target Aspirated Ceramic Pyrometer

This device measures the gas temperature indirectly, by aspirating a sample of the gas through a porous target of refractory material, and measuring the target radiometrically. Figure 7, Hot Target Aspirated Ceramic Pyrometer, shows the general arrangement. This has been reproduced from Reference 17. The figure shows a photodiode could be located remotely and coupled by a fiber optic cable. The walls of the sensors could be cooled by compressor discharge air. However, some energy is used in both the aspiration and cooling processes. Characteristics of the sensor are:

- Indirect Measurement
- Immersed probe with some disturbance on the measured gas stream
- Uses infrared radiation from a heated target.
- Use of single color or two-color detection of the target radiance is possible.
- Local sample of gas only
- Can be ruggedly constructed, but depends on air cooling to prevent melting and loss.
- Aspirated passage and cooling passage may need periodic cleaning maintenance.

#### Hot Target Unshielded Metal Pyrometer

This sensor measures the gas temperature indirectly by immersion of the sensor in the gas stream. Figure 8 shows the arrangement. The metal jacket, closed at the outboard end, is heated by the gas flow and the interior becomes a radiating cavity. A sapphire crystal is used as a high temperature light pipe to conduct the internal tip radiation to a fiber optic cable in a cooler

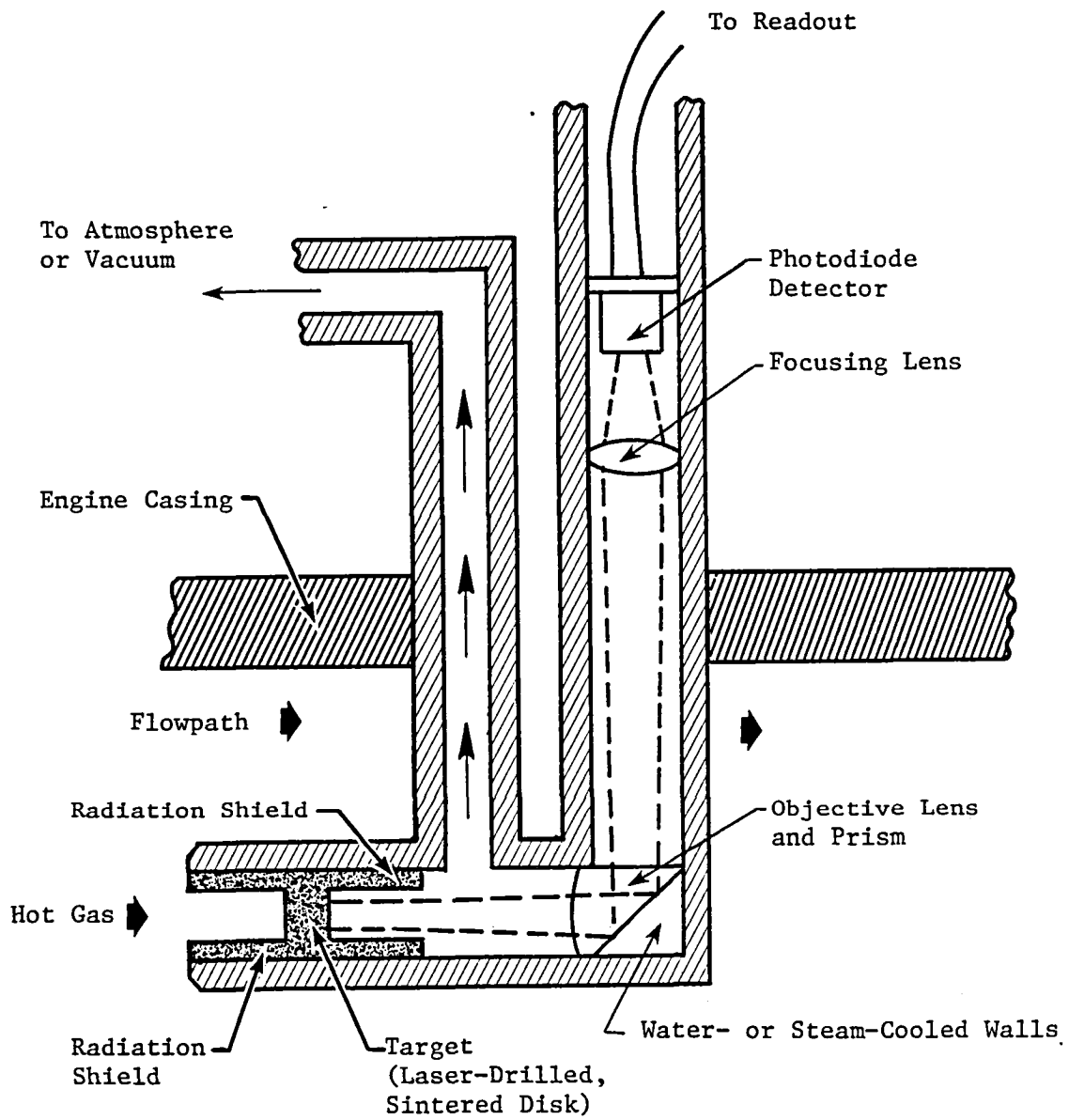

Figure 7. Hot Target Aspirated Ceramic Pyrometer.

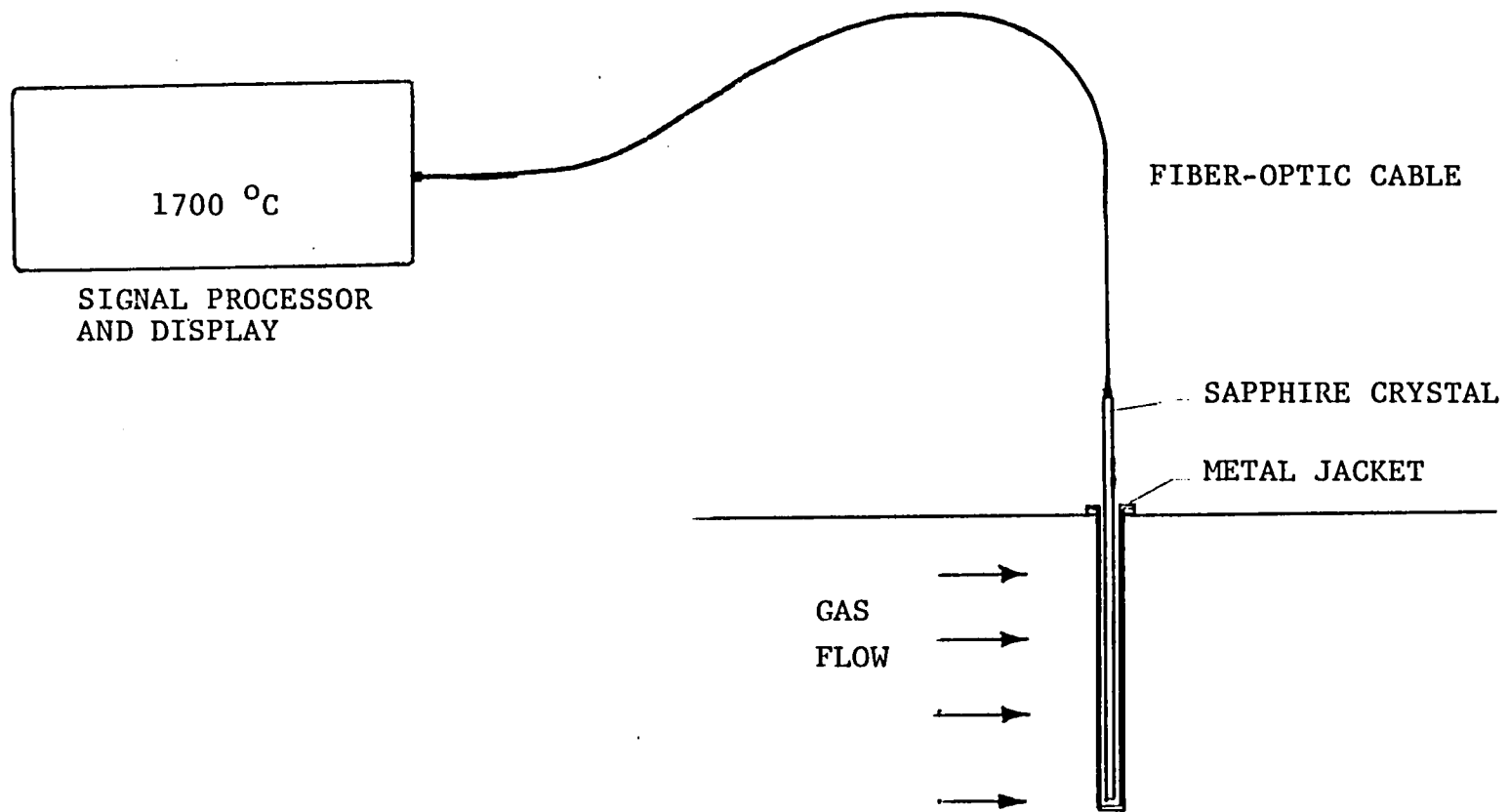

Figure 8. Hot Target Unshielded Metal Pyrometer.

region. The radiant energy is detected and processed at the Signal Processor and Display.

The metal jacket could be made of a platinum-family alloy which has good impact energy absorption at elevated temperatures. However, these alloys have low creep strength and also must be protected against loss due to volatile oxide formation. Characteristics of the sensors are:

- Indirect Measurement
- Immersed probe with local (but small) disturbance on gas stream
- Uses infrared radiation from protected cavity in the metal jacket.
- Single-color or two-color detection is possible.
- Local sample of gas only
- Mechanically simple design, but materials selection and protection are critical to success.
- Sapphire bulk optical properties may affect high temperature accuracy.

#### Sapphire Crystal Thermometer

This candidate sensor is similar to the hot target unshielded metal sensor except that the radiating cavity is formed on the tip of the light pipe. Figure 9 shows the simplest arrangement possible. Here, no protection or aspiration is used. Figure 10 shows the cavity-forming coating and various other coatings to protect the cavity and to protect the light pipe properties. No shield would be used.

An alternative configuration would be to place the sensing element in a shielded aspirated housing (Figure 11). This housing also provides protection against particle impact. This configuration is mechanically complex; thus, materials selection presents a problem. For this reason, the first configuration discussed above (the unshielded crystal) is preferred and was selected as one of the five candidates. Its characteristics are:

- Indirect Measurement
- Immersed probe with very small local disturbance on gas stream
- Uses infrared radiation from cavity on tip of light pipe.
- Single-color or two-color detection is possible.
- Local sample of gas only.

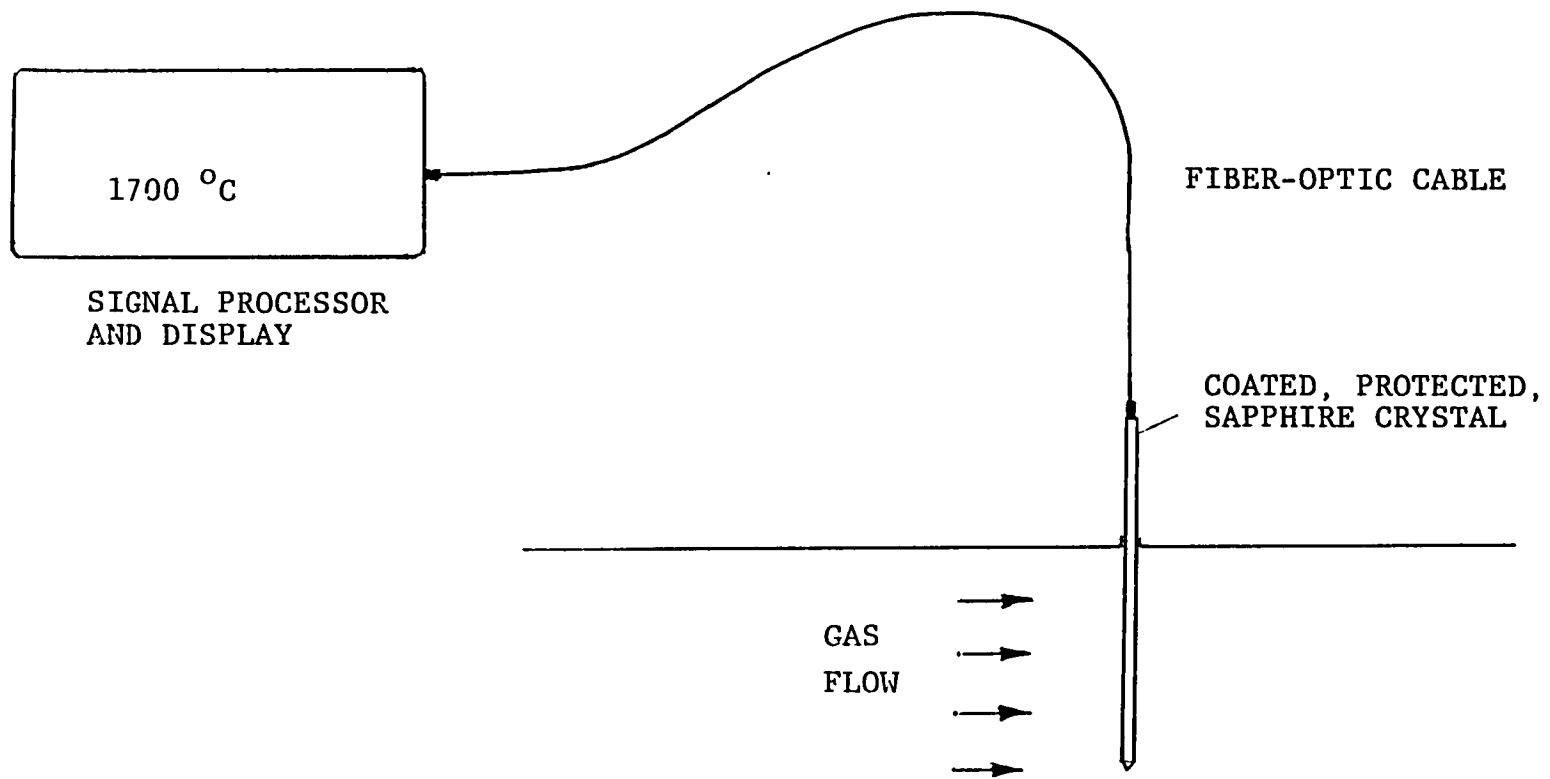

Figure 9. Sapphire Crystal Thermometer.

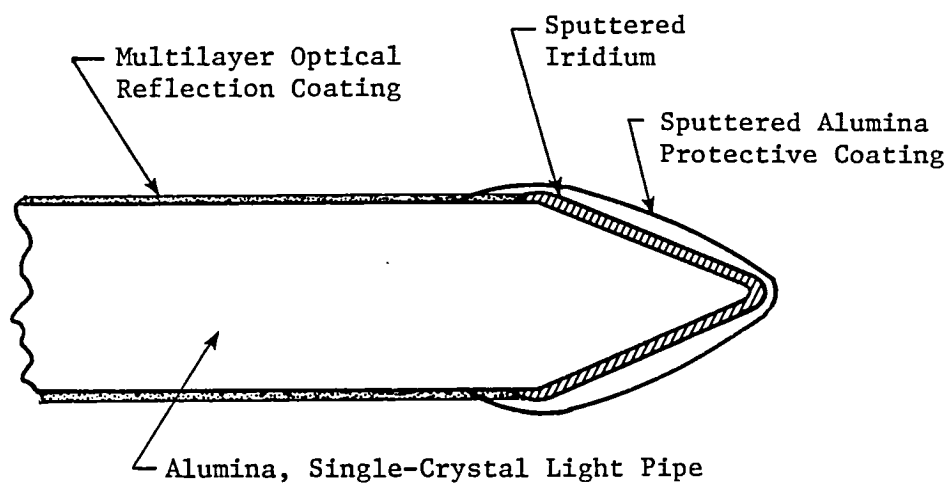

Figure 10. Protected Iridium-Tipped Light Pipe.



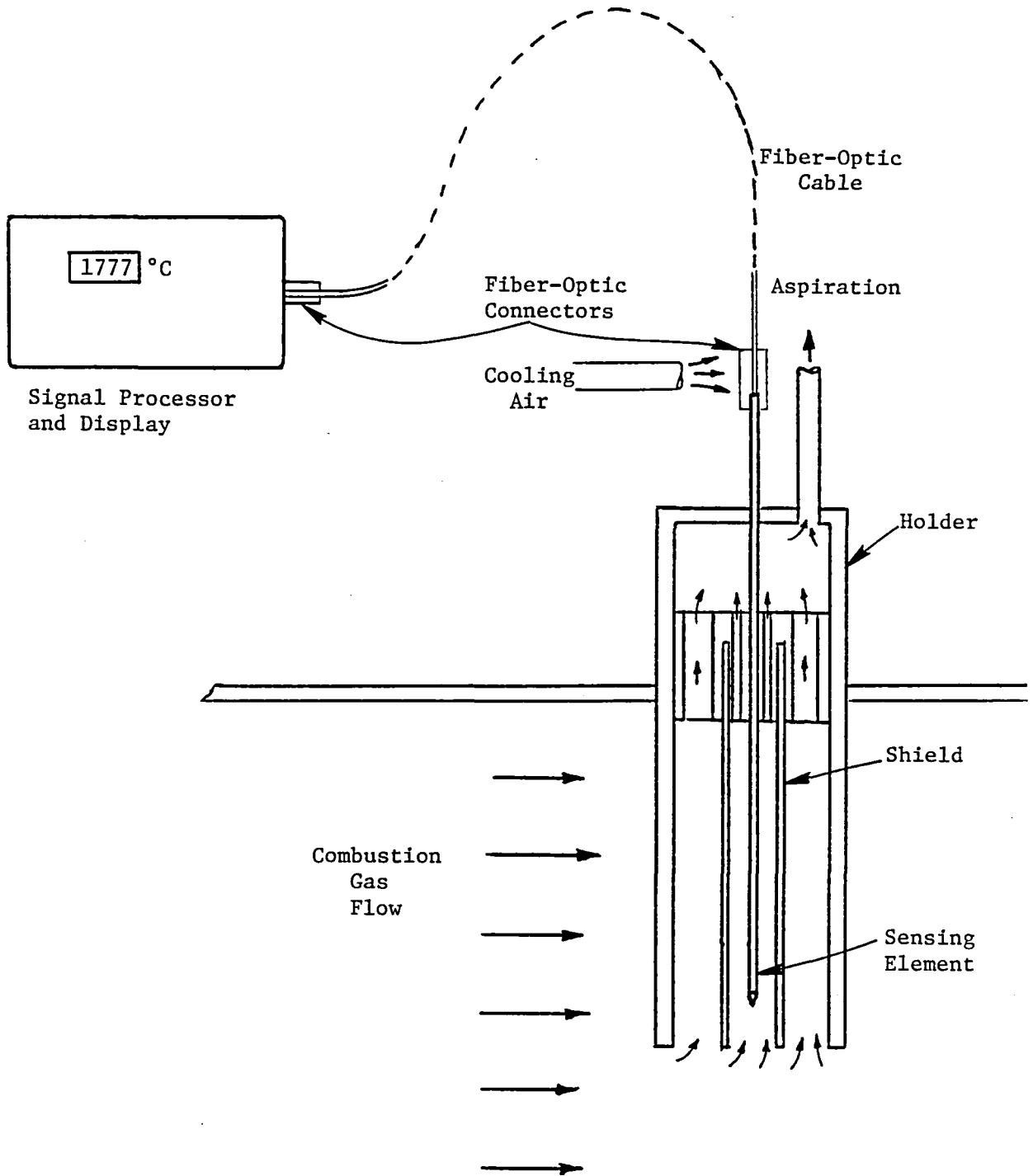

Figure 11. A Shielded Gas Temperature Measuring Probe and System.

- Mechanically simple design, but materials selection and protection is critical to success.
- Sapphire bulk optical properties may affect high temperature accuracy.

Table 5, the First Version Candidate Evaluation Chart, is explained as follows: The PARAMETER column (on the left) contains numbers that refer to Table 1, Evaluation Criteria-Parameter Value. The next column, IMPORTANCE, is a number between zero and 10, and appears on the right column of Table 1. Under each candidate are two columns. The left column of the pair is the rating number, between zero and four, that shows how well the parameter is satisfied by that particular candidate. The right column of the pair is the product of the importance number and the rating number. All products for a given candidate are summed to give a total score for that candidate. The candidate with the highest score, the Sapphire Crystal Thermometer, is 22 points above the second highest.

At the Review of April 1984, it was brought out that the Ratings for both the Gas Band and Particle Radiation Pyrometers may be too high. The wall radiation interference problem in the Gas Band Pyrometer could be more fairly rated in the temperature range Parameters 1, 4, and 7 by using ratings of 2, 2, and 2 in place of the 3, 4, and 4 ratings in Table 5.

Likewise, the anticipated lack of sufficient particles in the gas stream should be reflected in a reduced rating in the temperature range Parameters 1, 4, and 7 for the Particle Radiation Pyrometer. This could be more fairly rated by use of a 1, 1, 1 rating in place of the 3, 4, 4 rating in Table 5.

Three new Candidate Evaluation Charts were prepared with the above rating changes made. The three charts differ in the importance given to the Subidle Temperature Range and the Future Engine Temperature Range. Table 6 gives zero importance to both these ranges. Table 7 gives zero importance to the future engine temperature range, only. Table 8 uses the same importance for all temperature ranges as was used in Table 5.

### 3.8 SELECTION OF CANDIDATE PYROMETER

The contractor and customer mutually agreed upon completion of the Task I Review to pursue the Sapphire Crystal Thermometer as the selected candidate pyrometer.

Table 5. 1700° Optical Gas Temperature Sensor.

Candidate Evaluation Chart - First Version

Parameter	Importance	Gas Band Radiation Pyrometer		Particle Radiation Pyrometer		Hot Target Aspirated Ceramic		Hot Target Unshielded Metal		Sapphire Crystal Thermometer	
1	5	3	15	3	15	3	15	3	15	3	15
2	5	1	5	0	0	3	15	3	15	3	15
3	5	2	10	2	10	4	20	4	20	4	20
4	10	4	40	4	40	4	40	4	40	4	40
5	7	1	7	1	7	3	21	3	21	3	21
6	10	2	20	2	20	4	40	4	40	4	40
7	5	4	20	4	20	3	15	2	10	2	10
8	6	1	6	1	6	3	18	3	18	3	18
9	5	2	10	2	10	4	20	3	15	3	15
10	10	3	30	3	30	4	40	4	40	4	40
11	6	4	24	4	24	3	18	2	12	4	24
12	10	4	40	4	40	3	30	2	20	4	40
13	10	4	40	4	40	4	40	4	40	4	40
14	8	4	32	4	32	3	24	3	24	3	24
15	10	4	40	4	40	3	30	3	30	3	30
16	5	1	5	1	5	1	5	1	5	1	5
17	10	2	20	2	20	1	10	1	10	1	10
18	10	4	40	4	40	4	40	4	40	4	40
19	5	2	10	2	10	3	15	3	15	3	15
20	6	3	18	3	18	2	12	4	24	4	24
21	8	3	24	3	24	3	24	3	24	3	24
22	6	3	18	3	18	2	12	2	12	2	12
23	4	2	8	2	8	2	8	3	12	3	12
24	4	3	12	3	12	2	8	2	8	2	8
Total Score		494		489		520		510		542	
<p>Note: First Column: Rating (0 to 4)            Second Column: Product (Importance x Rating)            Total Score Line: Sum of Products for Candidate</p>											

Table 6. 1700° Optical Gas Temperature Sensor.

## Candidate Evaluation Chart - Second Version

Parameter	Importance	Gas Band Radiation Pyrometer		Particle Radiation Pyrometer		Hot Target Aspirated Ceramic		Hot Target Unshielded Metal		Sapphire Crystal Thermometer	
1	0	2	0	1	0	3	0	3	0	3	0
2	0	1	0	0	0	3	0	3	0	3	0
3	0	2	0	2	0	4	0	4	0	4	0
4	10	2	20	1	10	4	40	4	40	4	40
5	7	1	7	1	7	3	21	3	21	3	21
6	10	2	20	2	20	4	40	4	40	4	40
7	0	2	0	1	0	3	0	2	0	2	0
8	0	1	0	1	0	3	0	3	0	3	0
9	0	2	0	2	0	4	0	3	0	3	0
10	10	3	30	3	30	4	40	4	40	4	40
11	6	4	24	4	24	3	18	2	12	4	24
12	10	4	40	4	40	3	30	2	20	4	40
13	10	4	40	4	40	4	40	4	40	4	40
14	8	4	32	4	32	3	24	3	24	3	24
15	10	4	40	4	40	3	30	3	30	3	30
16	5	1	5	1	5	1	5	1	5	1	5
17	10	2	20	2	20	1	10	1	10	1	10
18	10	4	40	4	40	4	40	4	40	4	40
19	5	2	10	2	10	3	15	3	15	3	15
20	6	3	18	3	18	2	12	4	24	4	24
21	8	3	24	3	24	3	24	3	24	3	24
22	6	3	18	3	18	2	12	2	12	2	12
23	4	2	8	2	8	2	8	3	12	3	12
24	4	3	12	2	12	2	8	2	8	2	8
Total Score		408		398		417		417		449	

Table 7. 1700° Optical Gas Temperature Sensor.

Candidate Evaluation Chart - Third Version

Parameter	Importance	Gas Band Radiation Pyrometer		Particle Radiation Pyrometer		Hot Target Aspirated Ceramic		Hot Target Unshielded Metal		Sapphire Crystal Thermometer	
1	5	2	10	1	5	3	15	3	15	3	15
2	5	1	5	0	0	3	15	3	15	3	15
3	5	2	10	2	10	4	20	4	20	4	20
4	10	2	20	1	10	4	40	4	40	4	40
5	7	1	7	1	7	3	21	3	21	3	21
6	10	2	20	2	20	4	40	4	40	4	40
7	0	2	0	1	0	3	0	2	0	2	0
8	0	1	0	1	0	3	0	3	0	3	0
9	0	2	0	2	0	4	0	3	0	3	0
10	10	3	30	3	30	4	40	4	40	4	40
11	6	4	24	4	24	3	18	2	12	4	24
12	10	4	40	4	40	3	30	2	20	4	40
13	10	4	40	4	40	4	40	4	40	4	40
14	8	4	32	4	32	3	24	3	24	3	24
15	10	4	40	4	40	3	30	3	30	3	30
16	5	1	5	1	5	1	5	1	5	1	5
17	10	2	20	2	20	1	10	1	10	1	10
18	10	4	40	4	40	4	40	4	40	4	40
19	5	2	10	2	10	3	15	3	15	3	15
20	6	3	18	3	18	2	12	4	24	4	24
21	8	3	24	3	24	3	24	3	24	3	24
22	6	3	18	3	18	2	12	2	12	2	12
23	4	2	8	2	8	2	8	3	12	3	12
24	4	3	12	3	12	2	8	2	8	2	8
Total Score		433		413		467		467		499	

Table 8. 1700° Optical Gas Temperature Sensor.

## Candidate Evaluation Chart - Fourth Version

Parameter	Importance	Gas Band Radiation Pyrometer		Particle Radiation Pyrometer		Hot Target Aspirated Ceramic		Hot Target Unshielded Metal		Sapphire Crystal Thermometer	
1	5	2	10	1	5	3	15	3	15	3	15
2	5	1	5	0	0	3	15	3	15	3	15
3	5	2	10	2	10	4	20	4	20	4	20
4	10	2	20	1	10	4	40	4	40	4	40
5	7	1	7	1	7	3	21	3	21	3	21
6	10	2	20	2	20	4	40	4	40	4	40
7	5	2	10	1	5	3	15	2	10	2	10
8	6	1	6	1	6	3	18	3	18	3	18
9	5	2	10	2	10	4	20	3	15	3	15
10	10	3	30	3	30	4	40	4	40	4	40
11	6	4	24	4	24	3	18	2	12	4	24
12	10	4	40	4	40	3	30	2	20	4	40
13	10	4	40	4	40	4	40	4	40	4	40
14	8	4	32	4	32	3	24	3	24	3	24
15	10	4	40	4	40	3	30	3	30	3	30
16	5	1	5	1	5	1	5	1	5	1	5
17	10	2	20	2	20	1	10	1	10	1	10
18	10	4	40	4	40	4	40	4	40	4	40
19	5	2	10	2	10	3	15	3	15	3	15
20	6	3	18	3	18	2	12	4	24	4	24
21	8	3	24	3	24	3	24	3	24	3	24
22	6	3	18	3	18	2	12	2	12	2	12
23	4	2	8	2	8	2	8	3	12	3	12
24	4	3	12	3	12	2	8	2	8	2	8
Total Score		459		434		520		510		542	

## 4.0 DESIGN AND FABRICATION

### 4.1 SENSOR STRUCTURAL INTEGRITY AND OPTICAL PROPERTIES

Any indirect, immersed-type of sensing element will have to withstand the load of the flowing gas stream, engine vibration, and occasional particle impact. In addition, for the sapphire crystal thermometer the light pipe property of the crystal must be maintained.

An in-depth analysis of structural loading stress and the strength of two designs was performed and is presented in Appendix E. The cylindrical sensor was analyzed first. Problems foreseen in the cylindrical sensor led to the invention of a conical shaped sensor, which was also analyzed both mechanically and optically. The thermal characteristics, found to be applicable to the cylindrical and conical sensors, was analyzed and presented in Preliminary Design, Analytical Studies. Thermal commonality is reviewed in Appendix E.

#### 4.1.1 Cylindrical Sensor

The analysis in Appendix E showed that, for an immersion of 1 inch and a diameter of 0.040 inch, the stress at the base would approach 42,840 psi tensile. See Figure E-1. A shear stress of 570 psi was calculated. The cylindrical sensor depends on the light-pipe effect to provide the transmission of light from the tip cavity to the fiber optic cable. In turn, the light pipe effect works only with a clean or protected surface.

#### 4.1.2 Conical Sensor

The structural analysis given in Appendix E was for 1 inch immersion, a cone angle of 6.25 degrees, and the same gas stream conditions of Mach 0.2 and 400 psia. The maximum tensile stress was calculated to be 1016 psi. The shear stress was calculated to be 76 psi. See Figure E-2 of Appendix E. Optically, the conical sensor does not depend on the light-pipe effect but rather, the cone becomes a window for an image of the tip to be focused on the fiber optic cable tip. See Figure E-3 and the attendant text of Appendix E.

#### 4.1.3 Preferred Design

The conical sensor was preferred over the cylindrical sensor for the following reasons:

- Lower stress (40 times lower for the selected case)
- Freedom from calibration changes due to deposits on the surface exposed to the gas stream.

## 4.2 SENSOR HOLDER

The sensor holder supports the sensing element in the hot gas stream, supports the interfacing optic element(s), and the fiber optic cable. The assembly is supported by a cylindrical fitting. This is shown in Figure 12.

### 4.2.1 Thermal

In an engine application, cooling air would be available to limit the holder temperature. The actual temperature limit would be dependent on the engine model and cooling air source. For design purpose, the holder end nearest the combustion gas flow will be assumed to be hottest at up to 538° C (1,000° F) and the fiber optic termination will be limited to 80° C (176° F) so that plastic clad silica fiber may be used.

### 4.2.2 Optical, Fiber Optic and Connector

The theory behind the conical sensor was explained in Appendix E. The main elements, as shown in Figure E-3 "Conical Sensor Operation" may be compared with the cross-sectional illustration of Figure 12. In Figure 12, the fiber optic cable, 1, is threaded to attach to end piece, 3, with locking by nut, 2. The housing, 8, carries the solid single crystal aluminum oxide cone element 7, the aperture-spacer ring 6, the lens 5, and the image aperture - spacer ring 4. Housing 8 is attached to the simulated combustor wall 10 by compression fitting 9. A compliant sleeve of ceramic paper, 11, is positioned between the cone element 7, and the housing, 8. The tip of the cone element, 12, is the actual sensing zone. This zone is 0.35 inches long and has a sputtered refractory metal coating with an aluminum oxide protective overcoat. The measured temperature will be the average temperature along the 0.35" length of this sensing zone. However, it should be pointed out that sapphire exhibits bulk optical absorption properties that may be significant at high temperature. This was reported in reference 20. This could have the effect of extending the sensing zone.

Table 9 is a parts-list description and a specification for sensor and holder. Where a vendor part is listed, it is understood that an equivalent item from an alternative vendor could also be used. Figure 13 is a photo of the sensor assembled with uncoated cone next to uninstalled coated cone. A detailed mechanical drawing of the sensor assembly is shown in Appendix F.

## 4.3 ELECTRONICS

The electronics block diagram for the 1700° C gas temperature system is shown in Figure 14. The fiber optic cable from the sensor assembly terminates in an SMA style standard connector at the detector, a commercial two-color device, having two separate outputs. Each output is connected to an amplifier module. Module outputs are converted from analog to digital and input to a



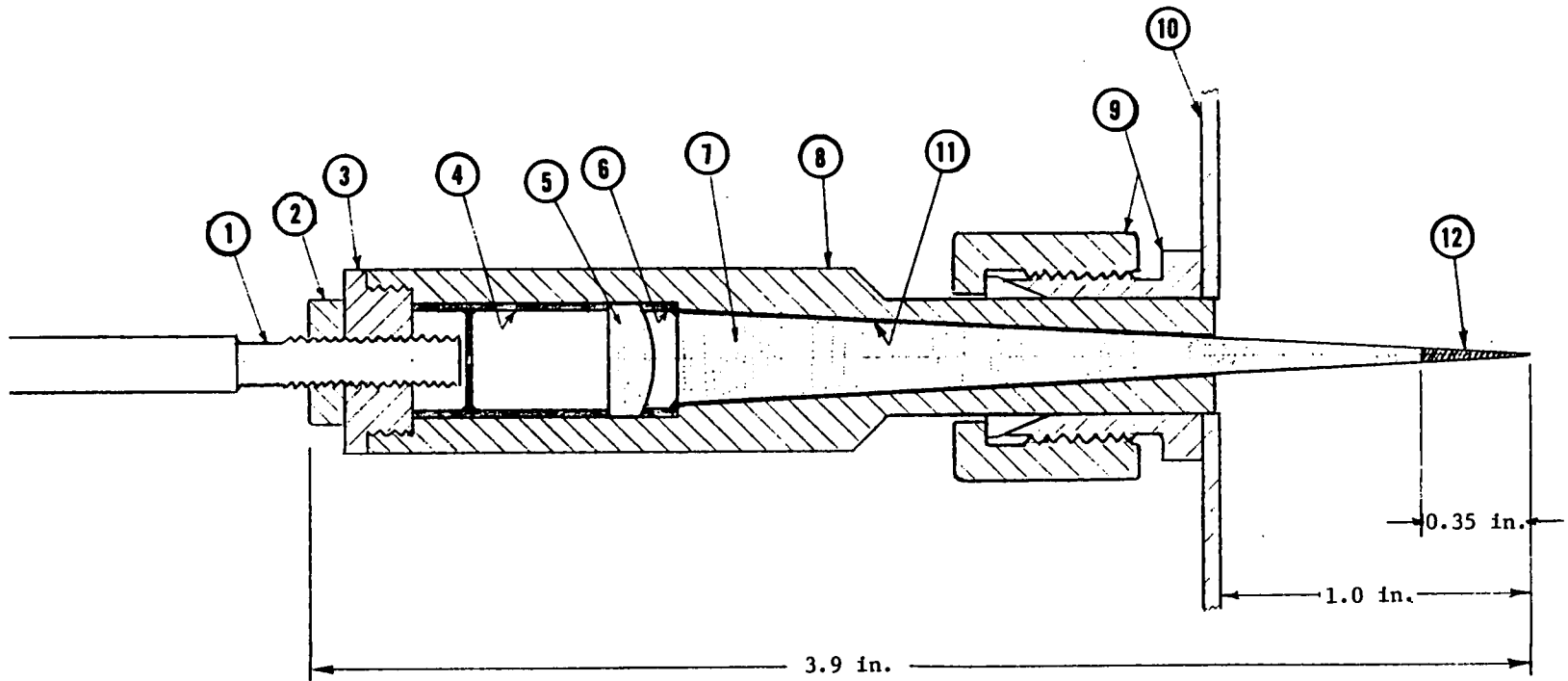

Figure 12. Optical Gas Temperature Sensor and Holder Assembly.

Table 9. Sensor and Holder Parts, Description and Specification.

<u>Part No.</u>	<u>Name</u>	<u>Description/Specification</u>
1	Fiber Optic Cable	200 micrometer core plastic clad silica, SMA style connectors, Newport Corp., part FCC-PC-2 (2 meters), FCC-PC-10 (10 meters), or equivalent.
2	Lock Nut	Part of inline adaptor, Newport part F-CA-001, or equivalent.
3	End Piece	Stainless steel 300 series.
4	Image Aperture- Spacer Ring	Stainless steel 300 series, 0.370 inch diameter, 0.630 inch long, aperture 0.007 to 0.010 inch diameter to match lens used.
5	Lens	Plano-convex, fused silica, diameter 0.30 inch, focal length 0.44 to 0.47 inch.
6	Aperture-Spacer Ring	Stainless 300 series, 0.370 inch diameter, 0.125 inch long, 0.260 inch aperture.
7	Cone Element	Sapphire, low scatter optical grade, 0.300 inch base, 2.74 inch height, zero degree orientation base flat to one wave vis. yellow, 80-50 polish. Cone side to be left fine-ground. Tip truncated 0.000 to 0.020 inch on height.
8	Housing	Stainless 300 series, 2.72 inches length, 0.60 inch maximum diameter.
9	Compression Fitting	Make from standard commercial 3/8 inch fitting stainless 300 series.
10	Simulated Combustor Wall	Stainless 300 series, 0.062 inch nominal thickness, size to fit bench experiment.
11	Sleeve	Ceramic paper, 1/32-inch thickness free-standing, Cotronics Corp. No. 300-020 or equivalent cut to provide one layer against cone element.
12	Tip	Length 0.35 inch nominal, defined by sputtered iridium coating with aluminum oxide overcoat.

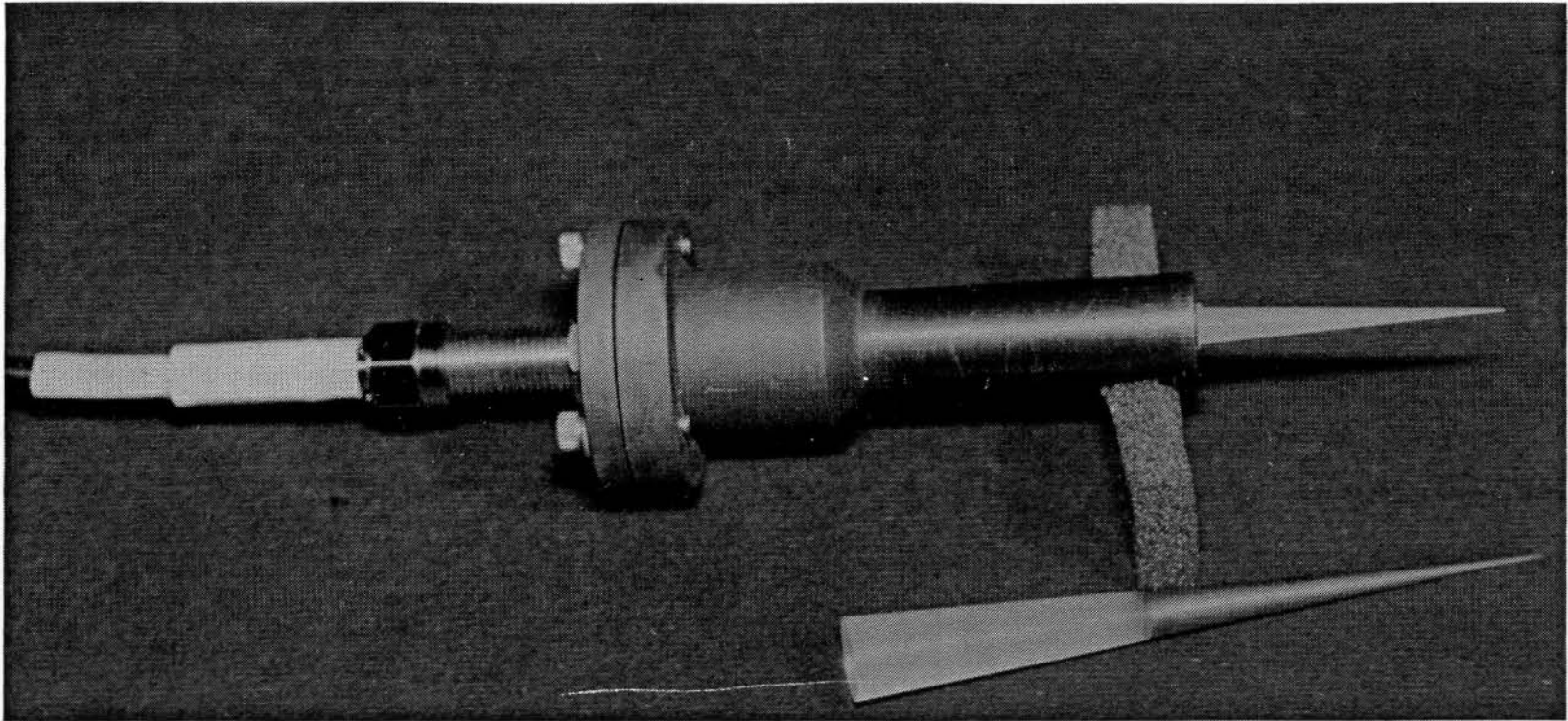

Figure 13. Photo of Sensor Assembly With Uncoated Cone Next to Uninstalled Coated Cone.

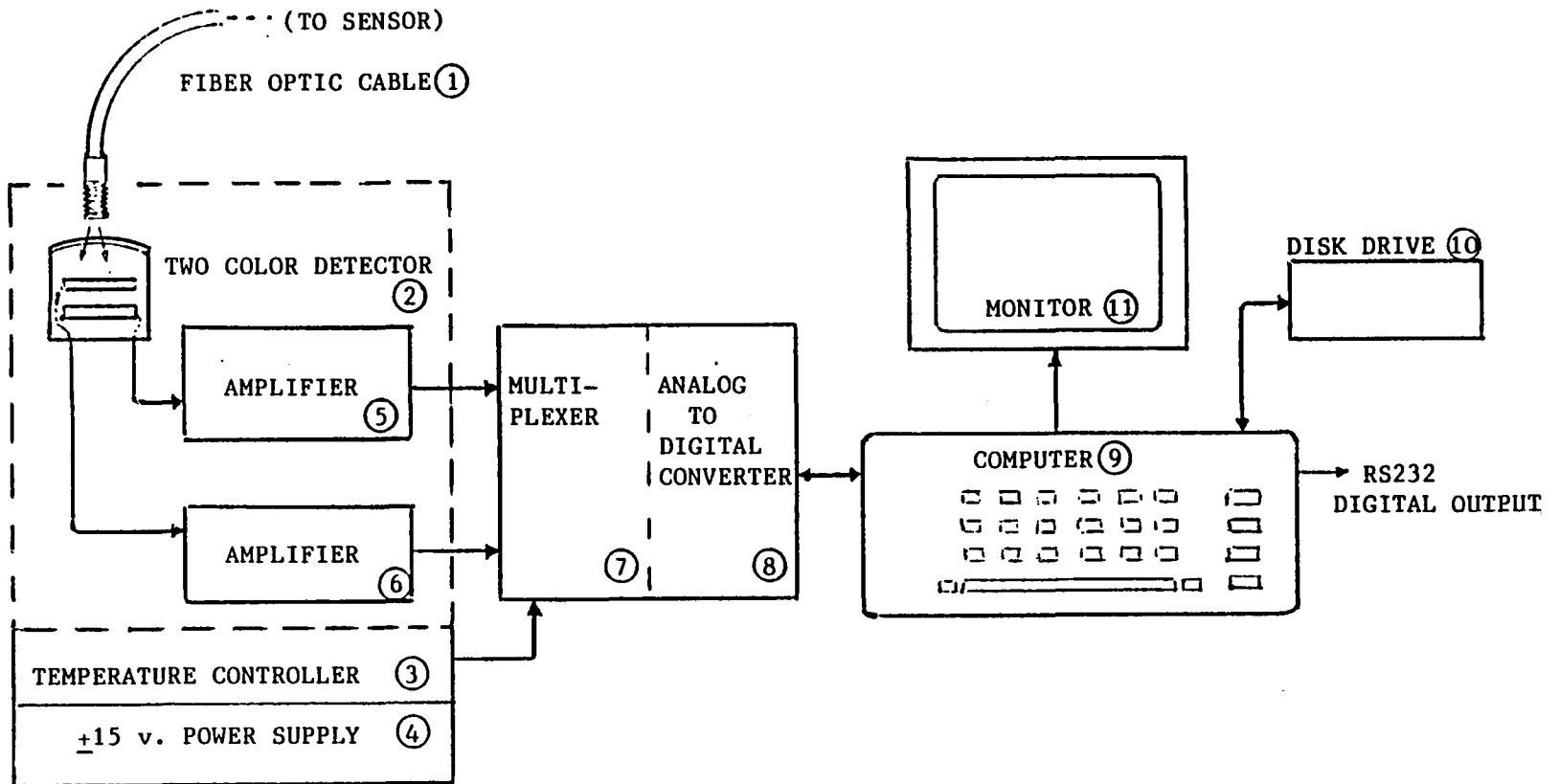

Figure 14. 1700° C Gas Temperature System - Electronics Block Diagram.

conversion program in a computer. The computer calculates the sensor temperature based on the sensor calibration data and then calculates the gas temperature for the given heat transfer environment of the sensor.

The components of this signal processing and computing system are listed in Table 10 with description and specifications. Where a specific manufacturer's model number is used, it should be recognized that an equivalent item from an alternate vendor could also be used. An electronics diagram in detailed form is presented in Appendix G.

#### 4.3.1 Detector

Several requirements became evident for the detector system. These are listed here:

- Efficient use of infrared/visible spectrum for adequate signal strength at engine idle of 520° C
- Spectrum within range of available fiber optics such as fused silica, 0.3 to 2.0 microns
- Wide dynamic range of signal processing capability due to the temperature span of 520 to 1700° C
- Capable of single or dual wavelength operation
- Stable optically, electrically, and mechanically.

The silicon detector for the above temperature range was chosen as having the best stability and other desirable features such as good linearity over a seven decade range. Stable operation from -55 to +150° C appears to be possible. Two methods are available to achieve dual wavelength (two color or color ratio) operation: one uses external filters such as dielectric interference types. The second method uses the window property of the silicon slice. This second method appears to have the advantage of superior long-term stability. The near infrared filters needed for the first method are not stable in high temperature and/or high humidity environments.

The selected detector uses the window filter property (second method). One vendor, EG+G Electro-Optics, has been manufacturing a product called "Two Color Detector" for several years. This unit has tandem silicon photodiodes in a hermetically sealed TO-5 package. Each photodiode has separate output wires. The top diode has a spectral range of 0.40 to 1.10 microns. This diode also acts as a window-filter for the second or bottom diode which has effectively a 0.95 to 1.10 micron spectral range. Overall, this detector is very efficient - it does not waste radiant energy in the 0.4 to 1.1 micron range.

The long wavelength cutoff is environmentally temperature dependent, as is true for all detectors. This amounts to about a +1% signal output change

Table 10. Electronics for 1700° C Temperature Sensor.

<u>Part No.</u>	<u>Name</u>	<u>Description/Specification</u>
1	Fiber Optic Cable	See Table 9.
2	Two-Color Detector	Tandem silicon photodiodes, TO-5 package, parallel outputs EG+G, Electro-Optics Div., or equivalent.
3	Temperature Controller	Feedback loop based on AD590 Temperature Transducer Analog Devices Corp. or equivalent.
4	Power Supply	±15 volt d.c. supply, Acopian DB15-20 or equivalent.
5, 6	Amplifier	Input range 1pA to 1mA, Analog Devices AD515LH or equivalent.
7	Multiplexer	16-channel analog input, part of DIADAC 1, Microtech Co. or equivalent.
8	A to D Converter	12-bit, memory mapped, part of DIADAC 1, Microtech Co. or equivalent.
9	Computer	BASIC in ROM, keyboard, accessories bus, 64K RAM, RS232-type output, Commodore C64 or equivalent.
10	Disk Drive	Single drive, 5-1/4-inch flexible disk Commodore 1541 or equivalent.
11	Monitor/Display	CRT based, audio speaker, Commodore 1702 or equivalent.

per degree C (diode case temperature) at 1.04 microns. Roughly, a 1° C change in diode case temperature would appear as a 1° C change in target (sensor tip) temperature when the target is at 1100° C. Thus, it is apparent that the diode case temperature must be either controlled or sensed and accounted for in the calculation of sensor tip temperature. Temperature control has been selected for this design.

#### 4.3.2 Amplifiers

The dynamic signal range is expected to be approximately 250,000 to 1 for the target temperature range of 520 to 1700° C. Even a 16-bit A to D converter cannot handle this dynamic range, being limited to one part resolution in about 65,000 parts. Two options are available: range changing and range compression. Range changing makes use of either switched amplifiers of various gains or switched gain on one amplifier. Range compression makes use of a nonlinear, but stable, device such as a diode- or transistor-based logarithmic amplifier. Range compression has the advantage of no discontinuities in time or calibration data since no switching is used. But a logarithmic amplifier with an input current capability as low as 1.0E-11 amperes was not available. Therefore, range changing was used by the technique of switching the gain on a state-of-the-art low input current amplifier. Supporting calculations of photodiode current versus temperature appears in Appendix H. The amplifiers were placed on the same temperature controlled-plate that holds the detector. Gain ranges are completely computer controlled or they may be controlled manually. Details appear in Appendix G.

#### 4.3.3 Analog to Digital Converter

A 12-bit analog to digital converter was used to convert the log amplifier outputs to digital form. A resolution of one-third of a degree C was expected over the 520 to 1700° C range. The A to D converter card also included a 16-channel multiplexer for analog inputs, a 12-bit digital to analog output converter, a battery-backed clock calendar, and 12-digital input/output lines.

#### 4.3.4 Computer, Display, and Printer

A personal computer, single-disk drive and CRT monitor, has been selected as the most efficient and versatile method to calibrate the gas temperature sensor and to provide the conversion from volts to degrees C. The computer also has the capacity to calculate the actual gas temperature from the sensor temperature when the sensors heat transfer environment is known. Note that the gas temperature will be equal to the sensor temperature only if the surrounding wall temperature is close to or equal to the gas temperature. This could be the case for an uncooled turbine, but it is not true for an engine area having cooled metal parts. Refer to the section on Analytical Studies and Figures 2 through 5 for a discussion and example calculations. A dot matrix printer was added in order to make permanent records of programs and data.

#### 4.3.5 Computer Programs

Four programs were used in the development of the temperature sensor. These will be briefly described here. Complete listings of the programs and remarks corresponding to program line numbers are included in Appendix D. All programs will run as-is on the C64 computer.

RESP-96D - This program is used to enter component calibration data from detectors, fiber optics, and spectrometer wavelength dial readings. The program also calculates spectral transmission of the individual fiber optics and detectors under test. The program was written by Paul M. Clark under this contract.

WAT-CA96D - This program takes the calculated spectral transmission data generated in RESP-96D and combines this data to yield system calibration curves. Since the spectral data is in small increments (0.01 micrometers), Planck's equation can be used to calculate system output versus target temperature. This is explained in the CALIBRATION section of this report. This program was written under contract by Paul M. Clark.

A/D READ M10 - This program operates the input multiplexer, the analog to digital converter, and looks up an indicated temperature using the system calibration curves. The program also looks up the time and date corresponding to the data acquisition cycle; it prints to either display monitor screen or to the dot matrix printer. This program is the only one needed to operate a probe that is already characterized. The program was written under contract by Paul M. Clark.

PM-TEMP4A - This program takes the indicated probe temperature and calculates the gas temperature based on input of the probe heat transfer environment. The program has the capability to be used in reverse. If the gas temperature and heat transfer environment are put into the program, the probe-indicated temperature will be calculated. This program was adapted for the C64 computer by Paul M. Clark from the thermocouple heat transfer correction program written (not under this contract) by Robert C. Williamson of General Electric Company. See Reference 11, Williamson and Stanforth, for a complete description of this work. It should be noted that this program was written for corrections to cylinder-shaped sensors in either pure perpendicular or pure cross flow. The application to a conical-shaped sensor was done by approximating the conical tip to a cylinder. A better approach would be to calculate the heat transfer environment to a cone using finite element methods, but this approach was beyond the scope of this contract.



## 5.0 CALIBRATION

Two approaches could be used to calibrate the sensor. Since the sensor uses radiant energy from a cavity to measure the temperature of the cavity, Planck's equation, which describes the radiant power at a given wavelength, could be used. This is the first approach. An alternate approach would be to calibrate the sensor against a reference sensor over the range. This alternate approach allows no extension of the calibration outside of the temperature range of the reference sensor.

The first approach was chosen because it not only allows extension (extrapolation) outside of the reference sensor temperature range, but it provides a self-check within the reference sensor temperature range. This will be described in detail. For the method to work correctly, Planck's equation must be applied over the entire spectral range of response - wavelength by wavelength.

The calculated detector output is found from the sum of every spectral wavelength contribution to the photocurrent as follows:

$$I_{TOT} = K \int_{\lambda_1}^{\lambda_2} D_{\lambda} (F_{\lambda}) W_{\lambda} \quad \text{Total Photocurrent Equation}$$

$$W_{\lambda} = \frac{C_1}{\lambda^5} \left( e^{\frac{C_2}{\lambda T}} - 1 \right)^{-1} \quad \text{Planck's Equation}$$

where

$I_{TOT}$  is detector output photocurrent, amperes

K is the system overall efficiency constant (dimensionless)

$D_{\lambda}$  is the detector spectral response function (dimensionless)

$F_{\lambda}$  is the fiber optic spectral response (dimensionless)

$W_{\lambda}$  is Planck's equation for spectral radiation: Watts/CM<sup>2</sup>/CM

$\lambda$  is the wavelength in centimeters (CM)

T = temperature, Kelvin degrees

$C_1 = 3.7413 \times 10^{-12}$  watt CM<sup>2</sup>

$C_2 = 1.4388$  CM degree

## 5.1 SPECTRAL RESPONSE CALIBRATIONS

Although manufacturers usually give "typical" spectral response curves, these have been found to be not sufficiently accurate for use in calibration of a precision sensor. Therefore, the spectral response was calibrated using the system shown in Figure 15. A tungsten strip filament lamp, GE 18AT10, was operated on a regulated direct-current supply. A condensing lens illuminated the entrance slit of a Bausch & Lomb Model 33-86-25-03 Grating Monochromator. At the exit slit is a Kodak No. 89B filter to block overlapping orders from the grating. This equipment was calibrated in terms of radiant power versus wavelength, using an EG&G detector SGD-100A Serial No. 01-03-008 which has an NBS traceable spectral calibration. Once calibrated, the spectral response of the holder, fiber optic, detector, and amplifier (as a system) was measured. The detector/amplifier system was then separately characterized. Both a 5-meter and a 10-meter length fiber-optic cable were characterized.

Computer program RESP-96D, described under the Design and Fabrication section and in the detailed listing in Appendix D, was written and used to enter the spectral data from the components in computer file form.

## 5.2 PRECISION RADIOMETRIC CALIBRATIONS

Next, the system overall efficiency constant, K, was found. This is illustrated in Figure 16. Figure 17 is a photo of the equipment set up to perform the precision radiometric calibration. The holder (without the crystal in place), fiber optic cable, and detector/amplifier were set up to view a blackbody radiation standard. The standard used was the Electro-Optical Industries Model WS154, having a 1-inch-diameter port and an 11-degree field of view. A type "S" thermocouple system, Kaye Instruments Ice Point Reference, and Medistor A-75A Precision Millivolt Potentiometer were used to set the radiation standard to the NBS traceable temperature levels.

When the constant K from the above equation has been found at one known temperature, the radiation standard was reset to a different temperature and the 1700° C system output indicated the temperature was compared. This calibration physically does the total spectral integration called for in the Total Photocurrent Equation above. The blackbody radiation standard effectively substitutes for the crystal, thereby providing the most accurate source of radiant temperature outside of melting point standards. This testing has given information on the tracking accuracy of the computed temperature calibration curve versus the actual data. The two methods agree to about 5° C.

The testing has also shown a repeatability of 2° to 3° C at 1000° C. Some temperature sensitivity on the optical fiber was discovered. This is correctable by proper design of optical stops and is discussed in the Results and Evaluation section.

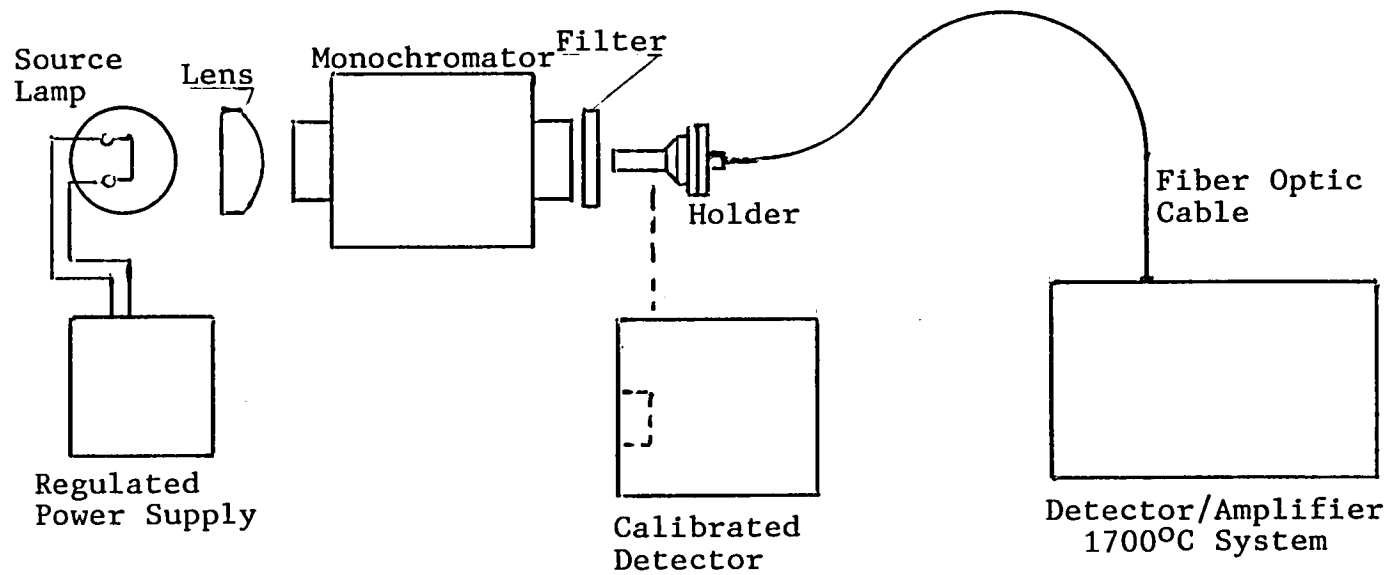

Figure 15. Spectral Response Calibration.

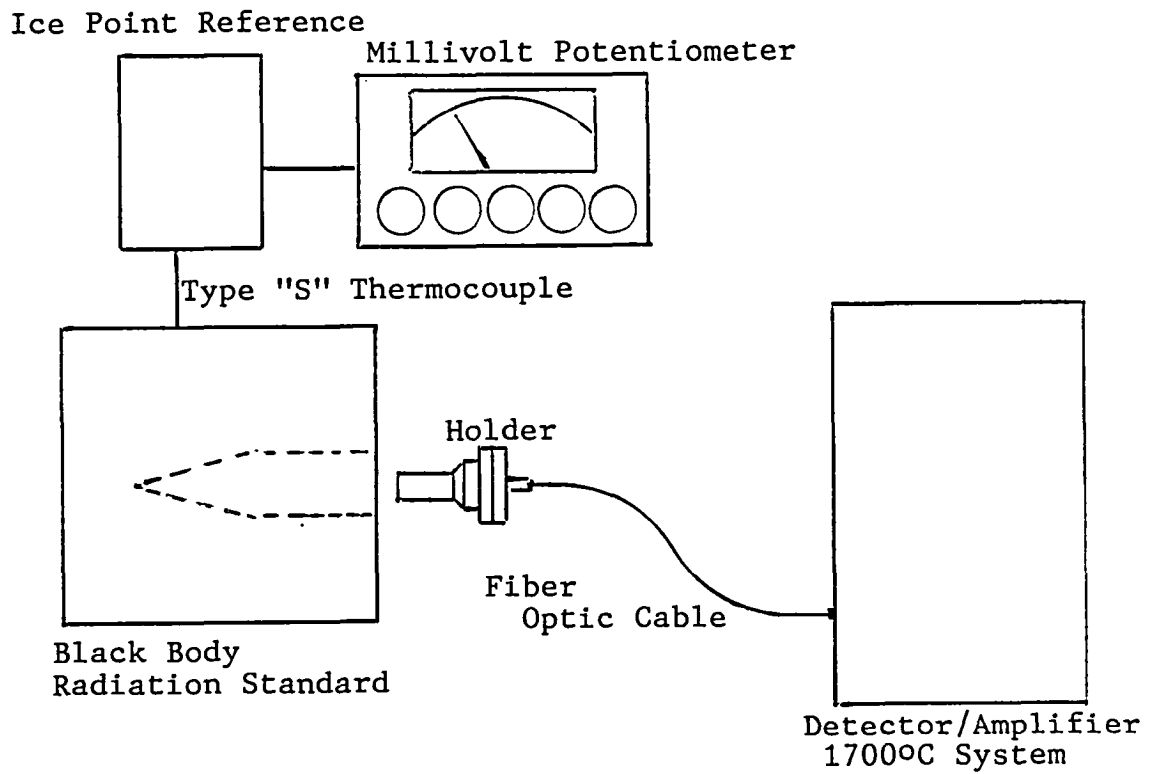

Figure 16. Precision Radiometric Calibration.

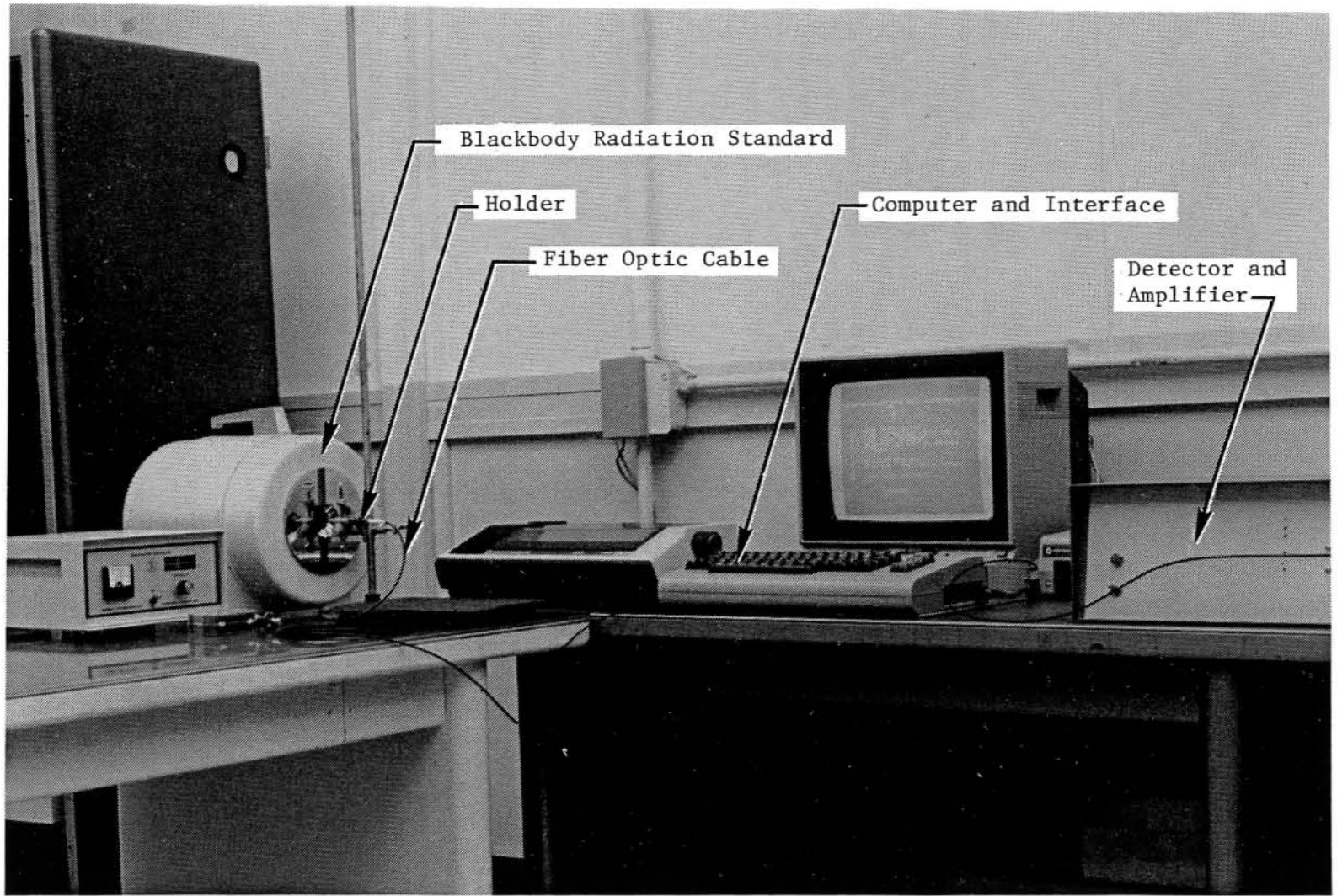

Figure 17. Photograph of Precision Radiometric Calibration.

## 6.0 TESTING

Tests were performed on components and on the system for the 1700° C gas temperature sensor. Several types of tests were considered necessary to fully characterize and evaluate the sensor. Two furnaces were constructed and a device to evaluate the coating integrity was built. These items will be described below.

### 6.1 FLAME-POWERED CAVITY FURNACE

An insulated furnace was built for the purpose of heating the sensor gradually and evenly. Figure 18 shows the setup used for testing. A propane-air burner was used for heating. A disappearing filament optical pyrometer was used to obtain a reference tip temperature. The Micro-Optical model by Pyrometer Instruments Company is designed to obtain radiant temperatures from very small targets, such as the tip of the cone sensor (0.005 to 0.015 inch diameter). This pyrometer has an NBS traceable calibration. The furnace operates by free convection with an internal velocity of 15 to 20 feet per second. The maximum temperature that the cone could be heated was 1350° C, even though the adiabatic flame temperature is 1920° C. This is because the low velocity results in a low coefficient of convective heat transfer. A second furnace was built for the purpose of heating the sensor in the range of 1350° to +1700° C. This will be described next.

### 6.2 VACUUM ASPIRATED FURNACE

This furnace was built to achieve an improved convective heat transfer coefficient on the sensing element. Figure 19 shows the general arrangement. The sensor tip was placed in a ceramic nozzle attached to a steel chamber. The chamber was attached to a vacuum pump. A propane-air torch was located to fill the flow entering the nozzle. The reference optical pyrometer was located to sight on the tip. A cool air source kept the fiber optic cable at a safe temperature. A differential pressure gage was used to monitor and control the vacuum applied and, thus, the flow velocity in the nozzle. The furnace was operated at about 220 feet per second; testing with a sapphire cone element achieved 1750° C. It was observed that the sensor tip temperature was very stable with time. Time response testing was done by chopping the torch flame with an aluminum plate "flag."

### 6.3 SENSOR AND COATING INTEGRITY TESTS

The purpose of the coating on the sapphire crystal cone element is to provide the blackbody radiation cavity. When this coating is applied correctly, it will have a very low light transmission. That is, it will be opaque. One can simply hold the cone against a uniform light source and check

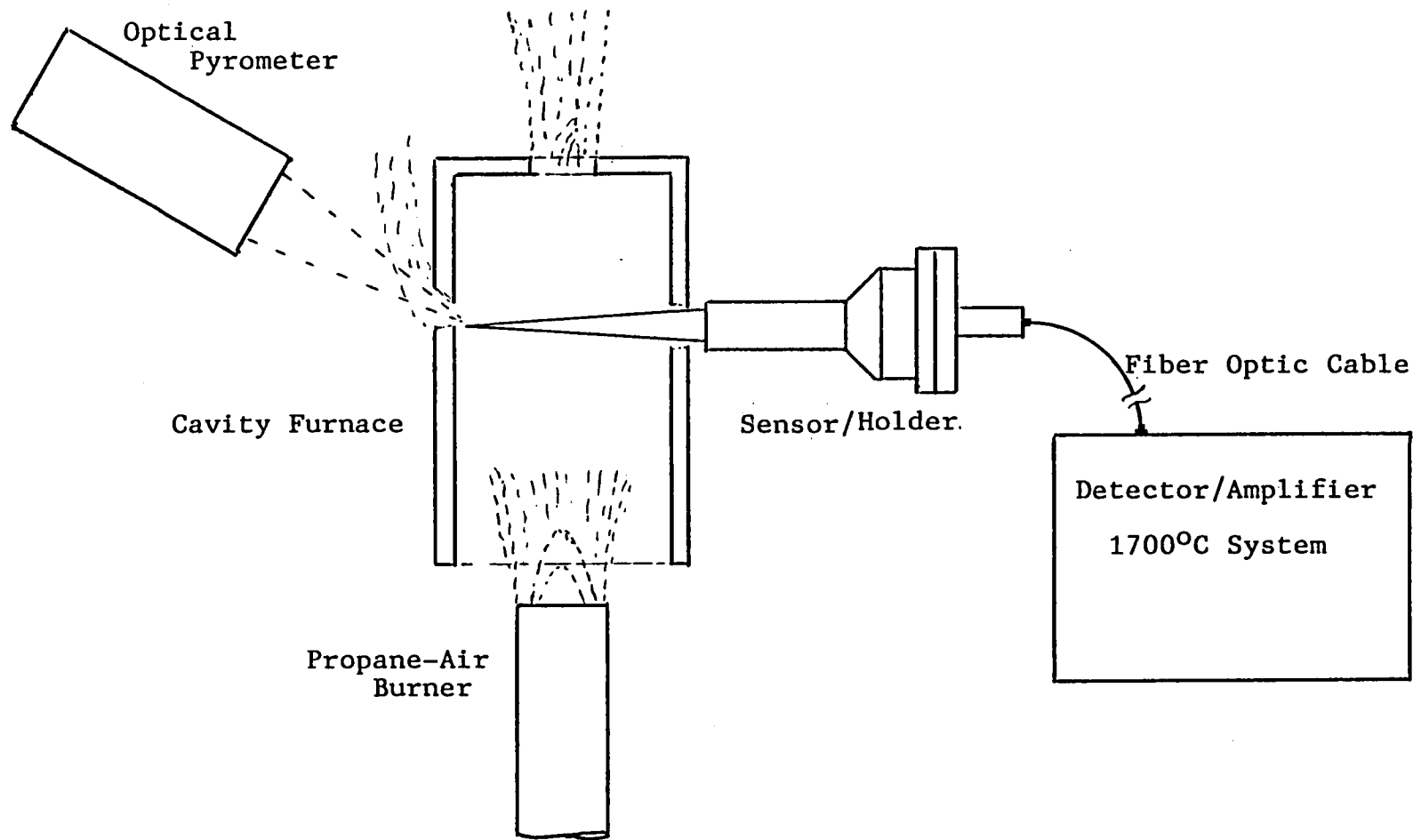

Figure 18. Flame-Heated Cavity Furnace Test Arrangement.

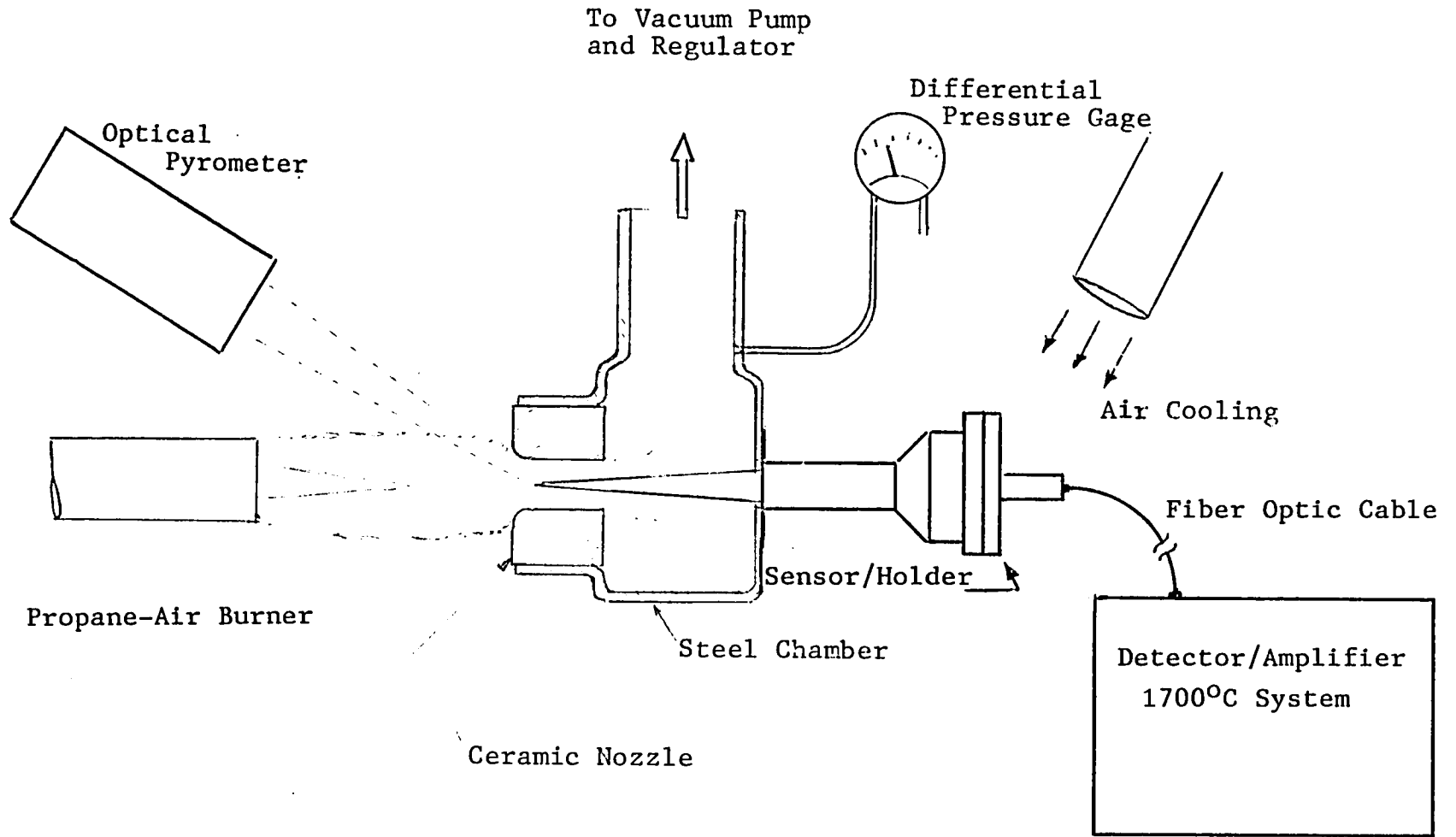

Figure 19. Vacuum Aspirated Furnace.



for transmission. However, it was desired to quantify this optical property, and a small fixture was designed. This is shown in Figure 20. A light source of high-intensity illumination projects light at an angle to the tip. A black paper mask prevents light from entering the cone in the uncoated region. A calibrated photodetector receives light from the base of the cone. An uncoated cone of the same dimensions was used to provide a benchmark. It was necessary to supply regulated power to the lamp to avoid false changes due to line voltage fluctuations.

Other coating integrity tests or evaluations used successfully were examined by optical stereo microscope and by scanning electron microscope. Direct weighing was attempted but was unsuccessful for the following reason: the weight of the film was estimated to be 50 to 100 micrograms. For the 3.8 gram cone, the electronic weight scale used exhibited a least count corresponding to 100 micrograms. Therefore, it became apparent that film weight loss or gain would be undetectable.

#### 6.4 SUMMARY OF TESTS

Four sapphire crystal cone elements were procured. Each element was nearly identical in length, cone angle, and weight. All had an optically polished base and a fine-ground cone side. Two elements were given a nominal 0.2 micron-thick platinum, 30% rhodium coating with a 1.5 micron aluminum oxide overcoat. The third element was given a 0.35 micron-thick platinum, 6% rhodium coating with no overcoat. The fourth element was left as-is for control purposes and was not coated. The tests are summarized in Table 11 and will be described here in chronological order.

Referring to Table 11, the cone elements Number 1 and 2 were given coatings as specified in Figure 21. The subcontracted vendor used continuous rotation in the sputtering chamber. The coated cones had a very uniform appearance, but were not optically opaque.

The as-received coated cone elements were tested for light transmission by comparing them to the light transmitted by an uncoated cone. One of these coated cones, Number 2 in Table 11, was set aside for use as a control.

The other coated cone element, Number 1 in Table 11, was given a progressive elevated temperature heat treatment. Gradual heating was done first in an argon atmosphere to 1000° C, then in an air atmosphere, also to 1000° C. The cone was weighed before and after heat treatment. The change was not significant (see discussion above). However, a light transmission measurement showed increased transparency after the heating. Under the microscope, no cracks, chips, or spalling could be found. The coating appeared to be adherent but thinner optically.

The system was tested with the heat treated, coated cone element No. 1 installed in the probe holder. A propane-air burner was used to provide a variable temperature source. A muffle furnace was used to create a uniform cavity so that a reference optical pyrometer could be used. Testing was done

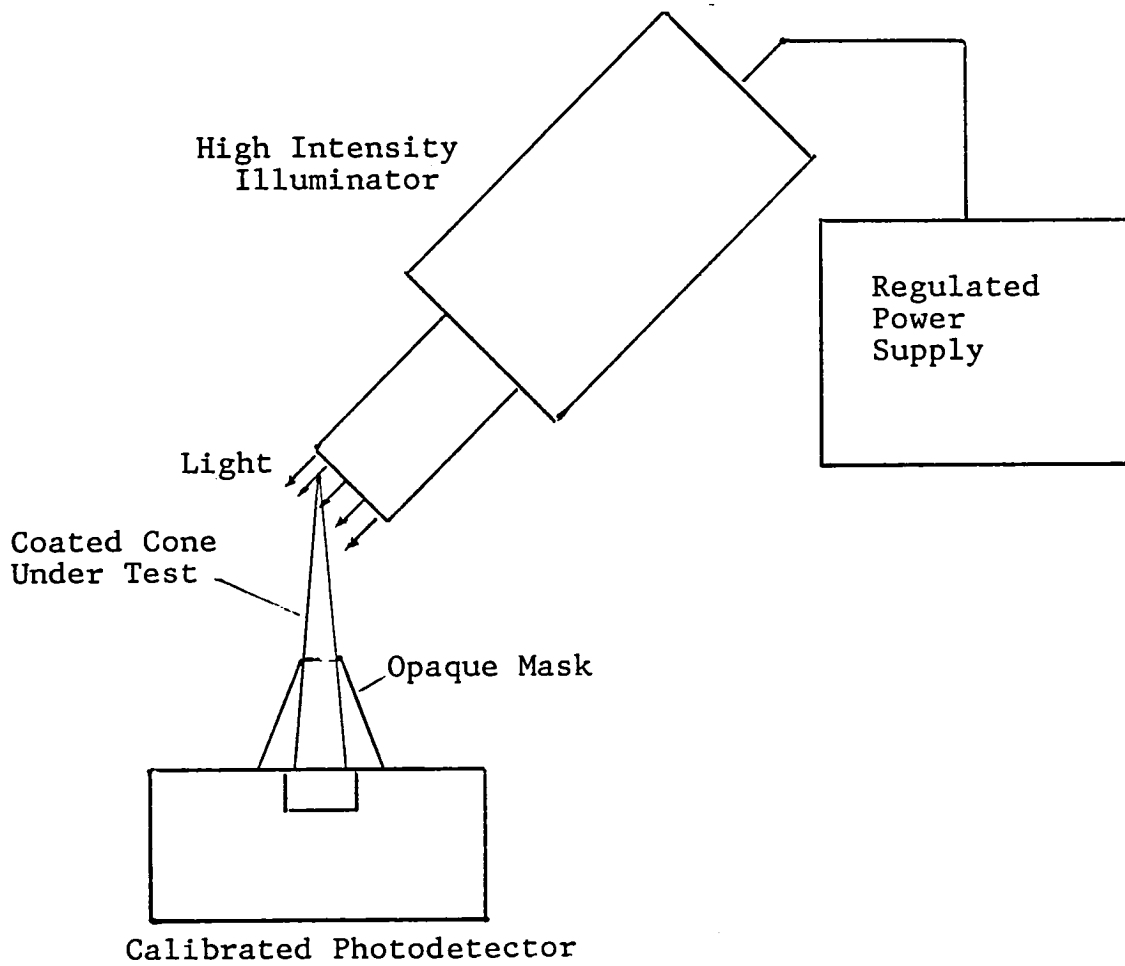
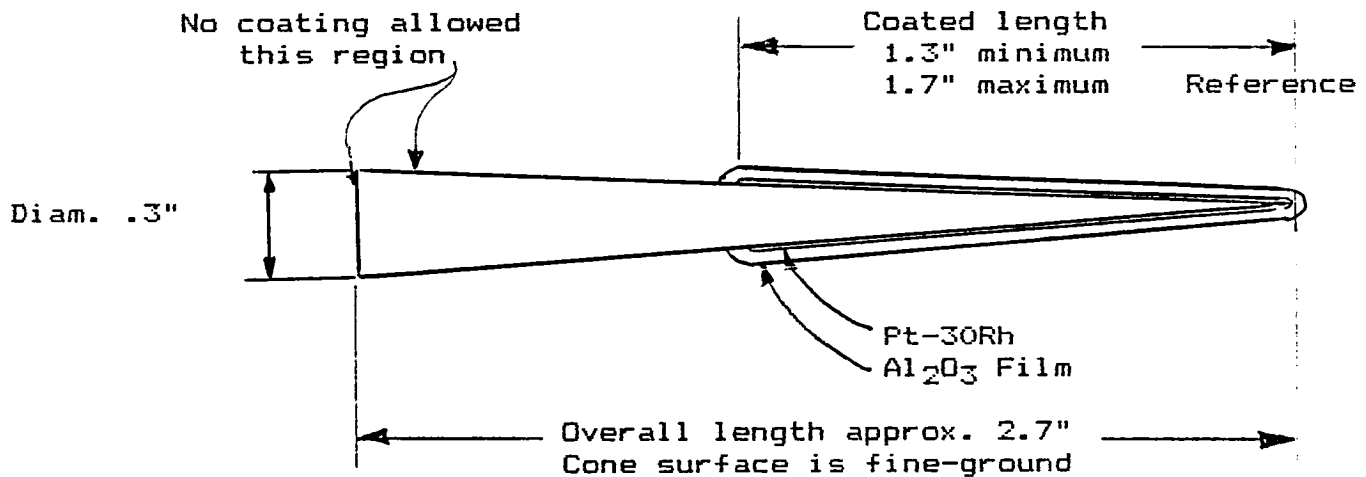

Figure 20. Coating Integrity Test Configuration.

Table 11. Test Summary Chart.

Cone Element	Coating/Overcoat Applied	C-C	Oven Argon at 1 ATM	C-C	Oven Air at 1 ATM	C-C	Propane Air Flame	C-C
1	0.2 Microns PT-30% RH/ 1.5 Microns Al <sub>2</sub> O <sub>3</sub>  *Continuous Rotation in Coating Chamber	G	RT to 760° C and Hold 1 Hour RT to 871° C and Hold 1 Hour RT to 982° C and Hold 1 Hour	G  F	RT to 871° C and Hold 1 Hour RT to 982° C and Hold 1 Hour	F  G	Heated in Steps to 1350°	P
2	Same as No. 1	G	None		None		None	
			Set Aside for use as a Control Sample)					
3	0.35 Microns PT-6% RH/ No Overcoat  *Two Positions in Coating Chamber, July 1985	E	None		RT to 260° C and Hold 1 Hour RT to 538° C and Hold 1 Hour RT to 816° C and Hold 1 Hour RT to 1000° C and Hold 1 Hour	E  E  E  E	Heated in One Step to 1750° C Heated RT to 1700° C and Return to RT Total of 107 Cycles	G  F
4	No Coatings		None		None		Heated to 1700° C and Return to RT Minimum of 25 Cycles	G
<p><u>C-C: Condition-Code</u></p> <p>E = Excellent G = Good F = Fair P = Poor</p>								



Objective: Apply uniform and adherent coatings of Pt-30Rh (2000 Å) ±20% thickness and overcoated with a thick coating of Al<sub>2</sub>O<sub>3</sub> (1.5 microns minimum thickness to provide protection of Pt-30Rh film from oxidation).

- Notes:
1. Masking must be provided to keep coatings confined to tip side of cones as shown.
  2. Vendor to be responsible for cleaning process.
  3. Samples should be rotated or, at a minimum, be manually turned at least once for each coating.

Figure 21. Sputter Coating of Two Sapphire Cones.

in steps up to about 1350° C. The platinum, 30% rhodium coating was examined visually after each temperature step (allowing the probe to cool first). Some increased transparency was noted after each step. The most significant change was seen after the immersion at 1350°C. It is believed that the coating oxidized and evaporated. The original specification called for a thickness of 0.2 microns. Based on the results so far, this may be too thin for the environment. There was some suspicion that the coating may have reversed sputtered, resulting in a thickness of less than the specified 0.2 microns. This thickness could not be measured without destroying the part.

One of the sapphire crystal cone elements, Number 3 in Table 11, was successfully coated in a new in-house facility. A platinum, 6% rhodium alloy was used. No alumina overcoat was used, so that the adhesion of the metallic coating could be evaluated. Some pinholes and scratches were evident, but are not in a location that would cause problems with the operation of the sensor. Coating was done with one manual rotation. Visually, a minor circular nonuniformity could be seen, but only under high intensity illumination internally.

This coated sensor, Number 3 described above, was given an elevated temperature soaking in air at four temperatures up to and including 1000° C. The holding period was one hour at each temperature. Preliminary inspection showed no distress from the heating.

The Number 3 coated cone sensor was next tested in the new vacuum aspirated furnace. The sensor indicated that a temperature of about 1750° C was reached. The optical pyrometer used as a reference indicated the tip temperature was within about 25° C of this value. After this, 107 cycles from room temperature to 1700° C were run. The platinum, 6% rhodium coating was examined under the stereo microscope. The coating appeared to have become thinner and darker.

Next, the sensor was examined with the aid of a scanning electron microscope. The pictures confirm that the coating is adherent and free of chips, spalls, and cracks. It was desired to obtain thickness information from the SEM pictures, but this could not be accomplished without cutting and polishing a section of the sapphire cone. This was considered undesirable because the cone sensor would be unusable if cut. The SEM pictures are reproduced in Appendix J.

Time-response tests were also run using the aluminum plate flag and the vacuum aspirated furnace. See the Results and Evaluation section.

## 7.0 RESULTS AND EVALUATION

Tests were designed to evaluate the parameters as listed in Table 12. Under "Accuracy" (Parameter 3) is included linearity, repeatability, and hysteresis. This table includes results in two columns: Evaluation Rating and Best Estimate and Comments. The evaluation rating is explained in the Preliminary Design section of this report.

### Calculation of Gas Temperature

An example calculation of gas temperature was done by using sensor (indicated) temperature from a particular reading taken during the tests in the vacuum aspirated furnace. Table 13 is a compilation of sensor mechanical data and known heat transfer environment data. From this set, program PM-TEMP4A was used to calculate the gas temperature for various combinations of equivalent sensor diameter and sensor emittance. Table 14 shows the results. In this example calculation, it can be seen that the gas temperature as calculated shows 80° C difference from extreme values taken for sensor external emittance and sensor equivalent diameter. In an actual engine, the mass flow parameter would be much higher than the 5 lbm/sec sq ft used here, and the range of calculated gas temperature would likely narrow to less than 10° C. This is evident in Figure 5, appearing earlier in this report, where the mass flow parameter reached a value of over 160 inside the engine at full throttle calculation.

Table 12. Test and Evaluation Results.

Parameter	Range or Goal	Evaluation Rating (See Table 2)	Best Estimate and Comments
1. Temperature	170° to 1700° C Emphasizing the 600° to 1700° C Range	3	510 to 1750° C
2. Resolution	± 1° C	4	± 0.1° C
3. Accuracy	± 2° C	2	± 25° C
4. Environment			
a. Media	Combustion Products of Hydrocarbon Fuel and Air	3	Some Loss of Coating Observed
b. Velocity, Pressure	Mach 0.2, 25 atm	3	Gas Loading Calculations
5. Time Response	3 Seconds for 63% of Step Change	4	Less than 0.25 Seconds
6. Endurance	100 Cycles, Room Temperature to 1700° C	2	Some Loss of Coating Observed
7. Installed	1000 Hours or More	1	Additional Devel- opment of Coating Needed
8. Induced Engine Losses	0.05% Maximum	4	Very Low Aerody- namic Blockage, Area Ratio 0.0003
9. Risk to Engine (Foreign Object Damage)	Estimate from Strength of Materials Used	3	Low Risk Predicted from the Stress Analysis
10. Vibration Endurance	Estimate Only	3	Thermal
11. Fiber Optic Coupling	6 Meters	4	5- and 10-Meter Lengths Used and Compared, a 6-Meter Length Would Have No Problem With Attenuation

Table 13. Constant Input Data.

Sensor Equivalent Diameter	Variable (See Table 14)
Sensor Equivalent Length	0.25 inch
Sensor Emittance (External)	Variable (See Table 14)
Flame Angle Factor	0.05
Flame Emittance	1.0
Mass Flow	5.0 lbm/sec sq ft
Wall Temperature	3281° R (1549° C)
Sensor (Indicated) Temperature	3581° R (1716° C)

Table 14. Gas Temperature Calculations.

Sensor Emittance, External	Equivalent Diameter, inches	Calculated Gas Temperature	
		° R	° C
0.4	0.016	3721	1794
0.5	0.016	3754	1812
0.6	0.016	3786	1830
0.4	0.032	3780	1827
0.5	0.032	3824	1851
0.6	0.032	3865	1874



## 8.0 DISCUSSION

The temperature range (see Table 12) found on this first sensor was 510° to 1750° C. The lower limit was determined by the decreasing signal strength; the upper limit is due to the melting point of the platinum, 6% rhodium coating, approximately 1830° C. This range will be well suited for gas turbine engine combustor discharge conditions at idle throttle and above.

The resolution result of 1° C is a good feature and stems from the low system noise and the use of the computer-controlled multiple-ranging amplifier and a 12-bit analog to digital converter. This is a real advantage over thermoelectric sensors where the very low output voltage makes the amplifier and system noise resolution-limiting.

The accuracy estimate of  $\pm 25^\circ$  C represents the difference between the reference pyrometer and the sensor taken at 90% confidence limit of error. This number is made up of several sources of error. This includes amplifier gain changes, noise, optical fiber temperature and stress effects, calibration coarseness, emissive coating physical changes, and sapphire crystal optical absorption effects. There are likely other effects present. The optical fiber temperature effect found was related to the particular fiber specification and the sensor optic design. It was discovered that the fiber transmission changed with fiber and end-fitting temperatures. It is theorized that the numerical aperture (NA) of the fiber was smaller than the NA of the sensor holder coupling lens and the two-color detector. Therefore, a change in the NA of the fiber due to temperature (or stress) would come right through the system. However, due to the characteristics of the two-color detector, most if not all of the transmission change is "cancelled" with regard to the indicated temperature. The residual effect seen was about 1° C of indicated target temperature change per 1° C of fiber optic temperature change. This problem has a solution which is described in the Recommendations section of this report.

Another effect on accuracy could come from the bulk optical absorption properties of sapphire (mentioned in the Design and Fabrication section of this report). The effect could be to extend the sensing zone beyond the emissive coated region of the sensing element. This possibility was not tested or analyzed, but it may have a significance, depending on the temperature gradient on the sensor.

The environment parameter consists of the media that the sensor is immersed in (combustion products) and the velocity/pressure effects that lead to physical stress. Generally, some loss of the emissive coating was observed in proportion to the time the sensor was immersed in the flame. The survivability of the sensor in a dense, high-velocity gas stream was estimated from gas loading calculations.

The time response was found by using a strip-chart recorder with a servopen. A 63% step change was seen as 0.25 seconds; this is also the nominal

response time of the recorder. It must be concluded that the sensor response time is less than 0.25 seconds.

The endurance and installed life goals fell short primarily due to the loss of emissive coating. There are several possibilities to improve coating durability; these are discussed in the Recommendations section.

The induced engine losses goal of 0.05% was met based on the calculated blockage area ratio of 0.0003.

The risk to engine (foreign object damage) of this sensor (due to breakage) is very low because of the low stress of the cone design. For the same reason the vibration endurance would appear to be good.

The fiber optic coupling requirement of 6 meters is quite acceptable, based on the low losses seen on both the 5- and the 10-meter fiber optic lengths.

## 9.0 RECOMMENDATIONS

The gas temperature measurement technique pursued in this contract uses infrared pyrometry techniques to sense the temperature of a small probe. The probe must be in good thermal contact with the gas stream for accurate measurement. This measurement technique was selected at the end of the preliminary design phase of the contract as the best choice. At this time of completion of the contract, there is no evidence that would change the evaluation criteria, or the rating that resulted, such that another technique would be favored. Nor has any novel technique emerged that would compete significantly with the chosen system. It is recommended, therefore, to not change from this measurement system approach.

Within this measurement system approach, however, changes or improvements are recommended to two of the three components: the sensor and the fiber optic. An option of increasing the low-end temperature measurements range is suggested for the third component, the detector package. These ideas will be discussed.

### 9.1 SENSOR

- A. For a solid sapphire sensing element, the effect of bulk optical absorption on the sensing zone length should be investigated.
- B. A more exact heat transfer analysis should be done for a conical-shaped sensor to improve the calculation of gas temperature.
- C. The durability of the sensor at elevated temperatures should be improved by one of the following approaches:
  - Use a thicker metallic emissive coating on the sapphire cone. Investigate protective coating(s) for the metallic coating.
  - Use an emissive material that is diffused into the sapphire instead of a coating.
  - Use a hollow refractory material cone instead of the solid cone of sapphire.

The third idea will be discussed in some detail. This concept has the potential of greatly extending the upper temperature limit of the sensor, while at the same time being more durable. The hollow refractory material cone for use as a sensing element is shown in Figure 22. The air or gas within the cone conducts the light rays (one is shown) that are emitted from inside the tip region of the cone. Just as in the solid sapphire cone, a lens collects and focuses the rays onto the optical fiber face. If the cone is not made of opaque material, then an emissive (and opaque) coating would be put on

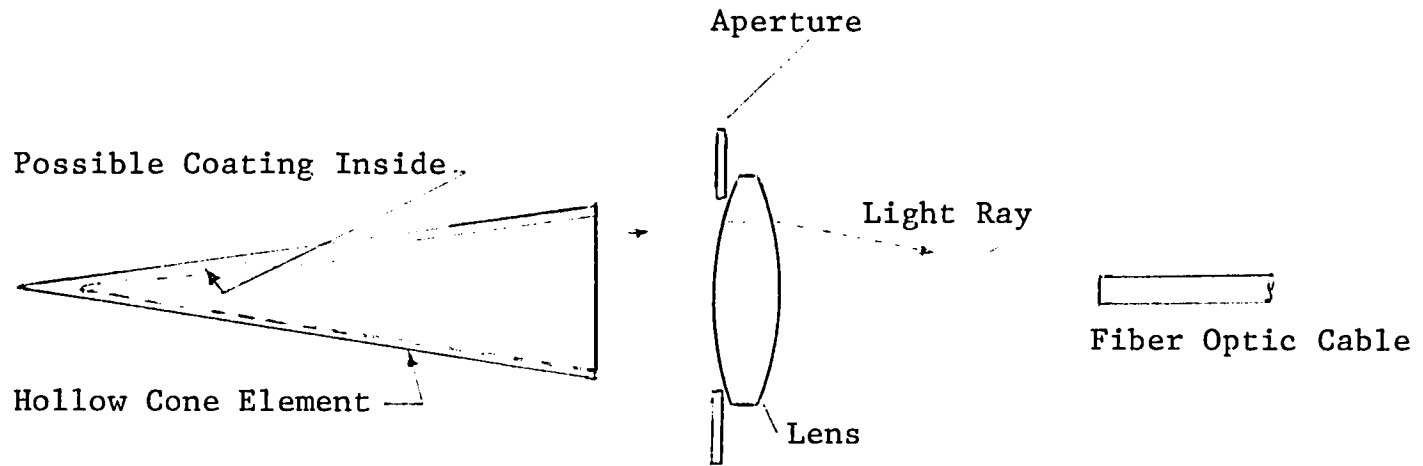

Figure 22. Hollow Refractory Material Cone for Use as a Sensing Element.

the inside of the tip region. This coating, if used, would be well protected since it is on the inside.

A great extension in both the upper temperature limit and in durability would come about by making this hollow cone of a refractory ceramic such as yttria-stablized zirconia. With a melting point of 2590° C, the material could be usable to possibly as high as 2450° C. This would amount to an extension of 500° C over the usable limit of 1950° C for a sapphire solid cone.

## 9.2 FIBER OPTIC

The fiber optic energy coupling should be improved by design so as to reduce or eliminate temperature effects on the energy transmission. From analysis of the current design, this improvement could happen by redesign of the optical stops, particularly the final stop at the detector. The goal would be to make the final stop numerical aperture slightly less than the optical fiber's lowest value of numerical aperture.

## 9.3 DETECTOR PACKAGE

An option of extending the lower temperature limit is available. This limit could be extended downward by substituting a longer wavelength detector. The spectral response of the detector must still be compatible with the optical fiber spectral transmission.

As an example, an indium-gallium-arsenide detector was chosen for calculation purposes. This detector is beginning to be used with certain fiber optics. It has a long-wavelength cutoff wavelength of 1.7 microns compared to the silicon longwave cutoff of 1.0 microns. Using this optical detector would extend the lower temperature limit downward to about 260° C. The current system with the silicon detector operates down to 510° C (see Table 12).

## 10.0 REFERENCES

1. Glawe, G.E., Johnson, R.C., and Krause, L.N., "Intercomparison of Several Pyrometers in a High Temperature Gas Stream," Temperature, Its Measurement and Control in Science and Industry, Reinhold Publishing Corporation, N.Y., 1962.
2. Bundy, F.P., and Strong, H.M., "Measurement of Flame Temperature, Pressure and Velocity," Physical Measurement in Gas Dynamics and Combustion Volume IX of the High Speed Dynamics and Jet Propulsion series, Princeton University Press, N.J., pp 343-388, 1954.
3. Kenworthy, M.J., Stanforth, C.M., Mossey, P.W., et al., "Investigation of Instrumentation and Simulation Techniques for the Supersonic Combustion Process," U.S. Air Force Aero Propulsion Laboratory, AFAPL-TR-66-76, October 1966.
4. Mossey, P.W., "Optical Ports," U.S. Patent No. 3,464,441 assigned to the U.S. Government as represented by the U.S. Air Force.
5. Buchele, D.R., "Computer Program for Calculation of a Gas Temperature Profile by Infrared Emission Absorption Spectroscopy," NASA TM 73848, 1977.
6. Mossey, P.W., "Experimental Pyrometer for Turbine Blade Temperature Measurement," SAE Paper 690431, National Air Transportation Meeting, New York, N.Y., April 1969.
7. Mossey, P.W., "Weighted Optical Temperature of Rotating Turbomachinery," U.S. Patent No. 3,696,678 assigned to General Electric Company.
8. Lapp, M., and Penney, C.M., Laser Raman Gas Diagnostics, a Project Squid Workshop, Schenectady, N.Y., 1973, Published by Plenum Press, 1974.
9. Salzman, J.A., Masica, W.J., and Coney, T.A., "Determination of Gas Temperatures from Laser-Raman Scattering," NASA TN D-6336, 1971.
10. Lynnworth, L.C., and Carnevale, E.H., "Ultrasonic Thermometry Using Pulse Techniques," Temperature, Its Measurement and Control in Science and Industry, Volume 4, Part 1, Published by Instrument Society of America, 1972.
11. Williamson, R.C., and Stanforth, C.M., "Measurement of Jet Engine Combustion Temperature by Use of Thermocouples and Gas Analysis," SAE Paper No. 690433, National Air Transportation Meeting, New York, N.Y., April 21-24, 1969.
12. James, K.A., Quick, W.J., and Strahan, V.H., "Analysis and Preliminary Design of Optical Sensors for Propulsion Control," NASA CR-159519, January 1979.

13. Bell, J.F.W., "Ultrasonic Thermometry Using Resonance Techniques," Temperature, Its Measurement and Control in Science and Industry, Volume 4, Part 1, Published by Instrument Society of America, 1972.
14. Glenn, W.H., Morey, W.W., and Snitzer, E., "Analysis and Preliminary Design of Optical Sensors for Propulsion Control," NASA CR-159468, March 1979.
15. Hall, J.A., "The International Temperature Scale," Temperature, Its Measurement and Control in Science and Industry, Proceedings of Symposia 2, pp 115-139, 1955.
16. Ksotkowski, Lee, Quinn, et al., "Intercomparison of the IPT568 Above 1064° C by Four National Laboratories," Paper 36, Temperature, Its Measurement and Control in Science and Industry, Volume 4, Part 1, Published by the Instrument Society of America, 1972.
17. Stanforth, C.M., Engel, M.E., and Hall, R.L., "Hot Target Sensor for High Temperature Gas Measurements," General Electric Company, TIS R73AEG483, December 1973.
18. Timoshenko, S., "Strength of Materials," Part I, Third Edition, D. Van Nostrand Company, Inc., 1973.
19. Keenan and Kaye, "Gas Tables," John Wiley and Sons, Inc., 1957.
20. Gryvnak, D.A., and Burch, D.E., "Optical and Improved Properties of Aluminum Oxide at Elevated Temperatures," Journal of the Optical Society of America, Volume 55, Number 6, pp 625, June 1965.

## APPENDIX A - BRAINSTORM SESSION FOR NEW SENSOR IDEAS

A brainstorm session was held on October 14, 1983 to look at all possible approaches to measuring the combustor discharge gas temperature in current aircraft gas turbine engines. Present at, and contributing to the list of ideas and concepts at this meeting, were Paul Clark, Paul Mossey, Ramayya Mulukutla, Wayne Shaffernocker, Chuck Stanforth, Bruce Stowe, and Bill Stowell.

The list of ideas was sorted after the session (without dropping any ideas) into the following grouping:

1. Basic Method:
  - A. Direct (Thermodynamic property to gas or trace particle)
  - B. Indirect (Immersed probe use)
2. Modification, Addition, Improvement, or Materials

### Basic Method, Direct

- Direct radiation of gas stream
- Carbon particle temperature
- Use CO<sub>2</sub> at a narrow spectral region of maximum optical absorption and shield pocket to obtain special resolution
- Use the temperature dependence of the infrared emission spectral line width of CO<sub>2</sub> or H<sub>2</sub>O
- Equilibria of NO<sub>2</sub> concentration (reference Jim Few or McGregor at AEDC)
- IR line reversal (like Na "D" line).

### Basic Method, Indirect

- Sapphire fiber blackbody concept as published by R.R. Dils
- Porous plug hot target - laser drilled
- Temperature-dependent fluorescent effect in a crystal
- Quarter wave stunt on end of sapphire
- Solid state Fabry-Perrot (Rockwell Company)
- Index of refraction versus temperature



- Optical transit in fiber or crystal
- Panametrics, Inc., work on ultrasonic temperature sensor
- Johnson Noise probe made with Pt Rh alloys or SiC or SiN<sub>x</sub>
- Bimetal effect, but use ceramics
- Thermal expansion effect measured by optical interferometry (Fenwick)
- Pulse probe with optical temperature sensor
- Fiber doped with sodium, and use line reversal.

Modification, Addition, Improvement, or Materials

- Single crystal of Si, Ge, or --- for long IR operation
- Time and temperature stability of doped target?
- Need shield material for sapphire fiber thermometer
  - Thoriated dispersed platinum
  - Sapphire fiber strengthened (dispersed in) platinum
  - Sapphire tube
  - Silicon carbide tube
  - Silicomp<sup>c</sup> or silicon nitride
- Doped sapphire to make end opaque (as a cavity)
- Contaminate the sputtering chamber to put opaque coating on fiber
- Sapphire fiber C-axis oriented, then cut the end at an angle
- Grown special end on sapphire fiber
- Do fiber endurance test early
- Flexible sapphire
- A.D. Little's work (bent crystal during pulling)
- Polarization effects of infrared
- Long wave infrared fibers that are flexible

- Convert polycrystalline refractory material to single crystal for use as light pipe
- Jointed mirrors in tubes for use as (long wave) light pipe

APPENDIX B - KEY WORD LIST - OPTICAL GAS TEMPERATURE SENSOR

- Gas Thermometer
- Refractory Optical Material
- High Temperature Optical Sensor
- High Temperature Optics
- High Temperature Fiber Optics
- High Temperature Optical Coating
- Optical Temperature Measurement
- Optical Temperature Sensor
- Gas Temperature Sensor (Measurement)
- Optical Sensor (s)
- Spectroscopic Temperature Measurement
- Passive Optical Sensor
- Electromagnetic Interference (EMI)
- Fiber Optic Sensor(s)
- Infrared Radiation Thermometer
- Gas Radiation Temperature
- Sapphire Crystal Thermometer
- Hot Target Sensor
- Turbine Inlet Temperature

## APPENDIX C - ANNOTATED BIBLIOGRAPHY

### Gas Temperature Measurement

1. Beretta, F., Cavliere, A., and Dalessio, A., "Visible and Ultraviolet Spectral Emission and Extinction Measurements in Oil Spray Flame," *Combustion Science*, April, 1980, p 1. Flame emittance and temperature profile were obtained with optical techniques. Spectral regions included the OH, CH, and continuum in absorption and emission from 0.28 to 0.8 microns wavelength. A swirling burner with Number 2 fuel oil was used.
2. Bundy, F.P., and Strong, H.M., "Measurement of Flame Temperature Pressure and Velocity," Physical Measurement in Gas Dynamics and Combustion, Volume IX of the High Speed Aerodynamics and Jet Propulsion series, pp 343-388, Princeton University Press, New Jersey, 1954. The use of the sodium "D" spectroscopic lines for temperature measurement, as well as pressure measurement is given. References important works relating to noncontact optical techniques.
3. Coleman, H.W., Hardesty, D.R., and Cattolica, R.J., "Diagnostics Assessment for Advanced Power Systems: Interim Report," Sandia Report SAND-77-8216, March 1977. Discussion and comparison of optical and nonoptical temperature measurements in hot gasses. Emphasis on Raman and CARS. Application towards pulverized coal and heavy residual fuel fired gas turbines.
4. Daily, J.W., and Kruger, C.H., "Effects of Cold Boundary Layers on Spectroscopic Temperature Measurements in Combustion Gas Flows," AIAA Paper 76-134, January 1976. This is an in-depth study of the use of spectral line reversal in gas temperature gradients. A valuable paper in this field.
5. Davis, L.B., Farrell, R.A., and Hill, W.E., "Total Flame Radiation and Two Color Flame Temperature in Industrial Gas Turbine Combustion Systems," ASME Paper 76-HT-57, August 1976. The method used assumes the flame to be a "gray body" in the radiation spectrum due to carbon particles present in the flame. Commercial pyrometer used.
6. Dils, R.R., "High-Temperature Optical Fiber Thermometer," *Journal of Applied Physics*, Volume 54 (3), March 1983, p 1198. This paper describes a thermometer with sensor made from a single crystal sapphire fiber, approximately one mm in diameter. A blackbody cavity is sputtered on the end of the fiber. A flexible glass fiber conducts the cavity radiation to a detector. A temperature range of 600° to 2000° C with precision of better than 1° C is claimed.
7. Engel, M.E., "An Investigation of the Thermal Characteristics of the Hot Target Sensor for High Temperature Gas Measurements," Master's Thesis, Department of Aerospace Engineering, University of Cincinnati, 1972. A detailed analysis of the heat transfer to and from the sensing element.

8. Entine, G., "Turbine Inlet Temperature Sensors," Final Report, Contract N00140-74-C-0583, Naval Air Propulsion Test Center, Trenton, New Jersey, 08628, August, 1974, by Tyco Laboratories, Incorporated, Waltham, Massachusetts, 02154. A sapphire light pipe, immersed in the hot gas, becomes incandescent and emits light. The light is transmitted through the sapphire pipe itself to the photosensor. The claim is made that the emission comes not from the surface of the probe tip but from the crystal bulk, making surface contamination have "little effect." In the general case, this is not true since light pipe operation is impeded by surface contamination. The claimed "little effect" could only happen under a special case of uniform temperature along the length of crystal subjected to surface contamination. Even with this flaw, the report deserves a special mention because it was apparently a pioneering work that, unfortunately, did not receive attention in this industry.
9. Fu, T., and Quan, M., "Gas-Temperature Measurement with Minimal Perturbation," NASA Tech Briefs, Spring 1983, p 305. This brief describes the method using two total heat flux calorimeters in contact with the gas and a third calorimeter that senses radiation only. The devices in contact with the gas are at differing temperatures. The measured gas temperature would be that at the calorimeter location, not out in the free stream. It would also seem important that the total calorimeters be physically located in such a way that each experiences a nearly equal heat transfer coefficient.
10. Ghezzi, U., Zizak, G., and Coghe, A., "Local Flame Temperature Measurements by Radiative Methods," AGARD Paper AD229, February 1978, p 35-1. Local flame temperature measurement at atomic fluorescence spectrometry. Line intensity ratios used. Gas stream seeded with gallium or indium or thallium. Typical errors of 2% to 4% of temperature were observed.
11. Glawe, G.E., Johnson, R.C., and Krause, L.N., "Intercomparison of Several Pyrometers in a High Temperature Gas Stream," Temperature, Its Measurement and Control in Science and Industry, Reinhold Publishing Corporation, New York, 1962. (1) The potential and limitations of several types of pyrometers for gas temperature measurement are given. Discusses sources of errors for each of the techniques.
12. Gottlieb, M., and Brandt, G.B., "Hot Spot Detection in Generators with Optical Fibers," ASME Paper 81-JPGC-PWR-18, October 1981. A joint EPRI-Westinghouse program led to the development of several methods of using optical fibers to detect the presence of thermal hot spots in remote locations in turbine generators. The fiber itself is used as the temperature sensor and also as the data transmission mechanism. One and two color pyrometry used. No test data.
13. Gottlieb, M., and Brandt, G.B., "Fiber Optic Temperature Sensor Based on Internally Generated Thermal Radiation," Applied Optics, October 1981, p 3408. This article is similar to the ASME paper, but it gives more detailed equations and actual test data using a germanium detector, starting at 140° C, and a silicon detector, starting at 240° C. A lead-sulfide detector was also proposed but not tested.

14. Goulard, R., Mellor, A.M., and Bilger, R.W., "Combustion Measurements in Air-Breathing Propulsion Engines: Survey and Research Needs," Combustion Science, November 1976, p 195. General discussions of a broad range of combustion measurements. Extensive references given. Refers to Project SQUID workshop at Purdue University, May 1975, and published as "Combustion Measurements," R. Goulard, editor, Academic Press, New York, 1976.
15. Hall, J.A., "The Internal Temperature Scale," Temperature, Its Measurement and Control in Science and Industry, Proceedings of Symposia 2, 1955, pp 115-139.
16. Hill, W.E., and Dibelius, N.R., "Measurement of Flame Temperature and Emittance in Gas Turbine Combustors," ASME Paper 70-GT-19, May 1970. An experimental method for measuring the temperature of luminous flames with a two-color pyrometer. Comparison with iridium versus iridium, 50% rhodium thermocouples. Emittance was calculated, various fuels were used from light through bunker "C."
17. Kayukawa, N., Aoki, Y., and Ozawa, Y., "Application of Light Polarization Techniques to the Generalized Line-Reversal Method for Gaseous Temperature Measurements," Review of Scientific Instruments, November 1982, p 1653. An improved line-reversal method, intended for fast transients, such as shock tubes.
18. Kostkowski, Lee, Quinn, et al., "Intercomparison of the IPT568 above 1064° C by Four National Laboratories," Paper 36, Temperature, Its Measurement and Control in Science and Industry, Volume 4, Part 1, Published by the Instrument Society of America, 1972. This paper is devoted to the high temperature end of the standards available. Correct and current values of all the melting point standards given.
19. Lynnworth, L.C., and Carnevale, E.H., "Ultrasonic Thermometry Using Pulse Techniques," Temperature, Its Measurement and Control in Science and Industry, Volume 4, Part 1, published by Instrument Society of America, 1972. This paper details the use of sonic velocity to measure gas temperature without immersed probes. Error sources mentioned. Transducer environmental sensitivity and delicateness a problem.
20. Mossey, P.W., "Weighted Optical Temperature Measurement of Rotating Turbomachinery," U.S. Patent No. 3,696,678, assigned to General Electric Company. This patent has claims for a method of turbine blade surface temperature measurement that rejects interference from the hot turbine gasses that intermittently contain incandescent particulates. Another claim is made for a method to measure the gas temperature by holding and processing the peaks that occur when the same particulates are present.
21. Rohy, D.A., Duffy, T.E., and Compton, W.A., "Temperature Measurements for Advanced Gas turbine Controls," AGARD Conference Proceedings, C57/AD151, February 1975, p 27-1. Eleven concepts were analyzed. The three best concepts chosen were the beta-ray sensor ( $\pm 2\%$  of temperature at best), the optical immersed target radiation pyrometer, and the ultra-

sonic air-gap. The application was for a turbine inlet gas temperature flight measurement system. No details or references given on the optical immersed target pyrometer.

22. Rohy, D.A., Seegall, M.I., and Compton, W.A., "Turbine Inlet Gas Temperature Sensor for Engine Control," Solar Division Research Report RDR-1748 (RTD FDL TR 73-49), AD765193, February 1973. A beta-ray absorption temperature sensing technique was designed, built, and tested. See comments in above Rohy reference.
23. (Sandia National Laboratories), "Ultrasonic Thermometer Measures High Temperatures," Machine Design, May 21, 1981, p 38. Thermometer measures high temperatures by sensing changes in the velocity of sound waves that travel along a thoriated tungsten wire. An accuracy of  $\pm 5^\circ \text{C}$  to  $600^\circ \text{C}$  and  $\pm 1^\circ \text{C}$  from  $1000^\circ$  to  $2845^\circ \text{C}$  is claimed.
24. Stanforth, C.M., Engel, M.E., and Hall, R.L., "Hot Target Sensor for High Temperature Gas Measurements," General Electric Company TIS R73AEB483, December 1973. Describes the design, construction, test, and analysis of the Hot Target Sensor. The most promising target material was made from yttria-stabilized zirconia. Aspiration was used to maintain moderately high gas velocity through the porous target, bringing the target temperature close to the gas temperature.
25. Tichenor, D.A., and Dils, R.R., "A Fiber Optic Probe for Measuring High Frequency Temperature Fluctuations in Combustion Gasses," SAND83-8871, Sandia National Laboratories, Livermore, California, February 1984. This report compares an analytical solution to some test data in order to assess the frequency response of the sapphire fiber thermometer.
26. Warshawsky, I., "Measurement of Rocket Exhaust-Gas Temperature," ISA Journal, Volume 5, No. 11, November 1958, p 91. A review of probe- and radiation-type temperature sensors, suitable for hot, high-velocity gasses. Error sources and temperature ranges are given for each technique.
27. Williamson, R.C., and Stanforth, C.M., "Measurement of Jet Engine Combustion Temperature by Use of Thermocouples and Gas Analysis," SAE National Air Transportation Meeting, Paper No. 690433, April 21-24, 1969. This is a comprehensive paper on high temperature measurement in gas turbine combustors. Error sources, system equations, and references are given.

#### Refractory Materials

1. Gryvnak, D.A., and Burch, D.E., "Optical and Infrared Properties of Aluminum Oxide at Elevated Temperatures," Journal of the Optical Society of America, Volume 55, Number 6, June 1965, p 625. The absorption coefficient of single crystal aluminum oxide (sapphire) is given versus temperature and versus wavelength.
2. Larsen, D.C., and Adams, J.W., "Property Screening and Evaluation of Ceramic Turbine Materials," Semiannual Interim Technical Report No. 12,

Contract No. F33615-79-C-5100, U.S. Air Force, by IIT Research Institute, Chicago, Illinois, May 1982. Strength Characteristics given for a wide variety of ceramics.

3. Materials Selector, published by Materials Engineering (Journal), Penton/IPC, Cleveland, Ohio, December 1984. Has tabular listings of significant materials properties of refractory metals and ceramics.
4. Musikant, S., "Optical Materials," Volume 6 in the Optical Engineering Series, Marcel Dekker, Inc., New York, 1985. The selection and application of materials for optical applications.
5. (Union Carbide), "Optical Properties and Application of Cz Sapphire," Electronic Materials Division, San Diego, California, 1980. This brochure compiles the most useful optical, physical, chemical, and thermodynamic properties of single crystal aluminum oxide, grown by the Czochralski (Cz) process.



APPENDIX D - COMPUTER PROGRAMS

D1 - RESP-96D

D2 - WAT-CA96D

D3 - A/D READ-M10

D4 - PM-TEMP4A

APPENDIX D1  
COMPUTER PROGRAM RESP-96D

```

2 REM PROGRAM 'RESP-96'
4 REM DATE: 4-26-85
5 REM CALC OF DETECTOR RESPONSE CURVES
6 REM 96 ITEM FILES
10 DIM A$(18,8),A(18,100),ZT(18,100),ZS(18,100)
16 GOTO100
18 PRINT"INITIALIZING TABLES PLEASE WAIT"
19 GOTO100
20 FORU=1TO18
21 PRINTU
22 FORV=1TO96
24 A(U,V)=1
26 NEXT
27 NEXT

100 PRINTCHR$(147)"***** RESP-96 MENU *****"
102 PRINT:PRINT
104 PRINT" 1 - INPUT DATA "
106 PRINT" 2 - EDIT DATA FILE"
108 PRINT" 3 - NORMALIZE DATA FILE "
110 PRINT" 4 - DIVISION OF FILES "
112 PRINT" 5 - SAVE ON DISK"
113 PRINT" 6 - LOAD FROM DISK"
114 PRINT" 7 - PRINT FILE "
115 PRINT" 8 - CALC. LIGHT PIPE TRANS"
116 PRINT" 9 - CALC. DET. RESPONSE - CUT #1"
117 PRINT"10 - EDIT FILE HEADER "
118 PRINT"11 - READ DISK ERROR CODE"
130 K=0:INPUT"COMMAND";K
132 IFK<1THEN100
134 IFK>11THEN100
136 ONK GOTO200,260,400,500,600,700,800,900,1000,1100,1200

200 PRINTCHR$(147)"***** INPUT DATA *****"
202 PRINT:PRINT
206 PRINT
208 GOSUB1200
209 PRINT
210 L$="":INPUT" FILE NUMBER = ";L$
211 IFVAL(L$)>18THENGOTO210
212 HH$="":INPUT"ENTER LETTER DESIGNATION OF FILE NUMBER ";HH$
213 L=VAL(L$):QQ$="":INPUT"INIT TABLE IF Y ";QQ$
214 GOSUB2100
216 A$(L,1)=L$:A$(L,3)="96":A$(L,2)="RESP-"+L$+HH$:W=.3
217 IFQQ$<"Y"THEN219
218 FORQ=1TO96:ZT(L,Q)=0:ZS(L,Q)=0:NEXT
219 P=1:INPUT"START AT I= ";P
220 PRINT:PRINT"INPUTS ARE:"
221 PRINT" VALUE = INCHES SCALE = VOLTS/INCH"
222 PRINT" OR"
223 PRINT" VALUE = VOLTS SCALE = MULTIPLIER"
224 PRINT:PRINT"ENTER E+LINE NO. TO MAKE CORRECTION"
225 PRINT:PRINT"LINE WAVELEN VALUE SCALE ENTRY"
226 FORI=PTO96
229 T$="":INPUT"VALUE = ";T$
230 IFLEFT$(T$,1)="E"THEN254
231 PRINT"?"TAB(15);:INPUT"SCALE = ";S$
232 IFLEFT$(S$,1)="E"THEN254
233 IFT$=""THEN238
234 W2=W+(.01*(I-1)):T=VAL(T$):S=VAL(S$)
235 A(L,I)=T*S
237 ZT(L,I)=T:ZS(L,I)=S
238 PRINT"?"
239 PRINT"?"TAB(2);:PRINTI
240 PRINT"?"TAB(6);:PRINTW2
241 PRINT"?"TAB(14);:PRINTZT(L,I)
242 PRINT"?"TAB(22);:PRINTZS(L,I)
243 PRINT"?"TAB(30);:PRINTA(L,I)
248 NEXT
249 FORK=1TO4000:NEXT
250 GOTO100
254 IFLEN(T$)<2THEN258
256 P=VAL(MID$(T$,2)):IFP>0THEN226
258 LL$="":INPUT"MENU IF Y ";LL$:IFLL$=""THEN100
259 INPUT"RESTART AT LINE ";P:GOTO226
260 PRINTCHR$(147)

```

```

261 PRINT"***** EDIT DATA FILE *****":PRINT:PRINT
262 PRINT"FILE NO = "L:INPUT"CHANGE TO ";L
263 IFL>18THENPRINT:GOTO262
264 U=1:INPUT"START AT ";U
265 PRINT"      VALUE          SCALE          ENTRY"
266 FORP=UTQU+10
267 PRINTP"      "ZT(L,P)"          "ZS(L,P)"          "A(L,P)"
268 IFP=96THEN270
269 NEXT
270 I=0:INPUT"CHANGE LINE NO ";I
271 IFI<1THEN281
272 IFI<UTHEN270
273 IFI>U+10THEN270
274 K2=0:INPUT"CHANGE VALUE ";K2
275 IFK2>0THENZT(L,I)=K2
276 K3=0:INPUT"CHANGE SCALE ";K3
277 IFK3>0THENZS(L,I)=K3
278 A(L,I)=K2*K3
279 IFK2>0THEN265
280 IFK3>0THEN265
281 LL$="":INPUT"MENU IF Y ";LL$
282 IFL$="Y"THEN100
283 U=U+11:IFU>96THEN264
284 GOTO266
288 GOTO100

```

```

400 PRINTCHR$(147)"***** NORMALIZE DATA FILE *****"
402 PRINT:PRINT
404 INPUT"ENTER SOURCE FILE NO. ";L
405 INPUT"ENTER DESTINATION FILE NO. ";LD
406 PRINT:PRINT
407 PRINT"SOURCE FILE HEADER:":PRINT
410 FORI=1TO8:PRINTI"      "A$(L,I):NEXT
420 PRINT:PRINT
422 LL$="":INPUT"MENU IF Y ";LL$
424 IFL$="Y"THEN100
430 A(L,0)=0
432 FORI=1TO96
434 IFA(L,I)>A(L,0)THENA(L,0)=A(L,I)
436 NEXT
438 PRINT:PRINT"MAXIMUM VALUE = "A(L,0)
440 IFA(L,0)=0THENPRINT"NO DATA FOUND IN FILE":GOTO472
450 FORI=1TO96
452 A(LD,I)=A(L,I)/A(L,0):PRINTI"      "A(LD,I)
454 NEXT
460 A$(LD,1)=STR$(LD)
462 A$(LD,2)=A$(L,2)+"-N"
464 A$(LD,3)=A$(L,3)
466 A$(LD,4)=A$(L,4)
470 PRINT"FILE "LD" IS NOW THE NORMALIZED VERSION OF CURVE "L
472 FORI=1TO4000:NEXT
474 GOTO100

```

```

500 PRINTCHR$(147)"***** DIVISION OF FILES *****"
502 PRINT:PRINT:L=0:INPUT"FILE NO. OF DENOMINATOR=";L
504 PRINT:LL$="":INPUT"ENTER Y FOR RECIPRICAL";LL$
506 IFL$="Y"THEN550
508 PRINT:INPUT"FILE NO. OF NUMERATOR=";LN
509 PRINT:PRINT"FILE "LN" IS TO BE DIVIDED BY FILE "L
510 PRINT:INPUT"DESTINATION FILE NO.=";LD
511 PRINT"FILE "A$(LN,2)"DIVIDED BY "A$(L,2);
512 PRINT"WILL BE LOCATED IN FILE "LD:PRINT
513 A$(LD,4)=A$(L,2)+" / "+A$(LN,2):A(LD,1)=STR$(LD):A$(LD,3)=96
514 LL$="":INPUT"MENU IF Y ";LL$
516 IFL$="Y"THEN100
520 FORI=1TO96
522 G2=A(L,I)
524 IFA(L,I)=0THENG2=1E-20
526 A(LD,I)=A(LN,I)/G2
528 PRINTI"      "A(LD,I)
530 NEXT
532 FORI=1TO4000:NEXT
540 GOTO100

```

```

550 PRINT:INPUT"DESTINATION FILE NO.=";LD
552 PRINT"RECIPRICAL OF FILE "L" IS TO BE STORED IN FILE "LD
554 PRINT"FILE "L" IS "A$(L,2)
556 LL$="":INPUT"MENU IF Y";LL$
558 IFLL$="Y"THEN100
566 FORI=1TO96
567 G2=A(L,I)
568 IFA(L,I)=0THENG2=1E-20
569 A(LD,I)=1/G2
572 PRINTI" "A(LD,I)
574 NEXT
578 FORI=1TO4000:NEXT
579 A$(LD,1)=STR$(LD):A$(LD,2)=A$(L,2)+"-R":A$(LD,3)=96
580 GOTO100

```

```

600 PRINTCHR$(147)"***** SAVE TO DISK *****"
601 PRINT:PRINT:PRINTK$" "B$:PRINT
602 GOSUB1604
620 L$="":INPUT"ENTER FILE NUMBER ";L$
622 HH$="":INPUT"ENTER LETTER DESIGNATING VERSION ";HH$
631 L=VAL(L$)
632 PRINTCHR$(147)
633 PRINT"FILE NAME IS RESP-";L$;HH$
634 PRINT:PRINT
636 PRINT"HEADER FOR FILE * "L$" * IS:" :PRINT
637 FORI=1TO8
638 PRINT"A$(I)" "A$(L,I)
639 NEXT
640 LL=0:INPUT"CHANGE LINE ";LL
641 IFLL<1THEN643
642 INPUT"ENTER CHANGE";A$(L,LL):GOTO632
643 LL$="":INPUT"MENU IF Y ";LL$:IFLL$="Y"THEN100
646 LL$="":INPUT"DELETE OLD FLIE IF Y ";LL$
647 IFLL$="Y"THEN680
648 K$="RESP-"+L$+HH$
649 L=VAL(L$)
650 OPEN15,8,15
651 OPEN2,8,2,"0:"+K$+",S,W"
652 INPUT#15,A$,B$,C$,D$
653 IFA$="00"THEN657
654 PRINTCHR$(147):PRINT:PRINT:PRINT:PRINT:PRINTTAB(12)B$
655 CLOSE2:CLOSE15:FORI=1TO3000:NEXT:GOTO600
657 FORU=1TO8
658 PRINT#2,"A"+A$(L,U)
659 NEXT
665 FORU=1TO96
667 PRINT#2,A(L,U)
668 PRINTU" "A(L,U)
669 NEXT
670 PRINT#2,"AEND"
672 CLOSE2:CLOSE15
674 GOTO100
680 OPEN15,8,15,"S:RESP-"+L$+HH$
682 CLOSE15
684 GOTO648
690 B$="":GOTO100

```

```

700 PRINTCHR$(147)"***** LOAD FROM DISK *****"
702 PRINT:PRINT:PRINTK$" "B$:PRINT
703 GOSUB1604
704 L$="":INPUT"ENTER FILE NUMBER ";L$
705 HH$="":INPUT"ENTER LETTER DESIGNATION OF VERSION ";HH$
706 LL$="":INPUT"MENU IF Y ";LL$
707 IFLL$="Y"THEN100
710 K$="RESP-"+L$+HH$
718 OPEN15,8,15
720 OPEN2,8,2,"0:"+K$+",S,R"
721 INPUT#15,A$,B$,C$,D$
722 IFA$="00"THEN725
723 PRINTCHR$(147)"*****"PRINTTAB(12)B$
724 CLOSE2:CLOSE15:FORI=1TO3000:NEXT:GOTO100

```

```

725 FORU=1TO8
726 INPUT#2,C$(U)
727 PRINTC$(U)
728 NEXT
730 CLOSE2
732 L=VAL(MID$(C$(1),2)):PRINT"FILE NO.= "L
734 PP=VAL(MID$(C$(3),2)):PRINT"FILE CONTAINS "PP" ITEMS"
740 LL$="":INPUT"MENU IF Y ";LL$
741 IFLL$="Y"THEN100
750 OPEN2,8,2,"0:"+K$+",S,R"
752 FORU=1TO8
753 INPUT#2,C$
754 A$(L,U)=MID$(C$,2)
755 NEXT
760 FORU=1TOPP
762 INPUT#2,A(L,U)
764 PRINTU"      "A(L,U)
766 NEXT
770 CLOSE2:CLOSE15
771 FORU=1TO500:NEXT
790 B$="":GOTO100

```

```

800 PRINTCHR$(147)"***** PRINT FILE *****"
802 PRINT:PRINT
804 GOSUB1600
806 B$(1)="FILE NUMBER      "
807 B$(2)="FILE NAME        "
808 B$(3)="DATA ITEMS IN FILE "
810 LL=0:INPUT"ENTER FILE NUMBER ";LL
812 P=1:INPUT"START LIST AT N= ";P
820 OPEN4,4,0:CMD4
830 PRINT"PRINTOUT OF DATA FILE ** PROGRAM * RESP-69A * "
832 PRINT:PRINT"DESCRIPTION:"
833 PRINT:PRINT:PRINT
834 FORI=1TO8:PRINTI"  "B$(I);A$(LL,I)"  " :NEXT
836 PRINT:PRINT"ITEM W/L  VALUE  "
838 FORI=PT096
840 PRINTI"  ".3+(.01*(I-1))"      "A(LL,I)
845 NEXT
848 PRINT#4:CLOSE4
850 GOTO100

```

```

900 PRINTCHR$(147)"***** CALC LIGHT PIPE TRANSMISSION *****"
902 PRINT:PRINT
904 PRINT"TOP * FILE 17 / FILE 11          DESTINATION FILE 4
905 PRINT"BOT * FILE 18 / FILE 12          DESTINATION FILE 4"
910 INPUT"LIGHT PIPE FILE";N
911 INPUT"DETECTOR FILE";D
920 A$(4,1)="4"
922 A$(4,3)="96"
924 A$(4,2)=A$(N,2)+"/"+A$(D,2)
926 A$(4,4)="FIRST CUT TRANSMISSION CALC."
940 FORI=1TO96
942 IFA(D,I)=0THENA(4,I)=0:GOTO946
944 A(4,I)=A(N,I)/A(D,I)
946 NEXT
962 GOTO100

```

```

1000 PRINTCHR$(147)"***** CALC DET. RESPONSE - CUT#1 *****"
1002 PRINT:PRINT
1004 C1=0:INPUT"DETECTOR FILE NO = ";C1
1005 PRINT:PRINT:PRINT"RB=(IB/IA)*RB"
1006 PRINT"IA IS EG&G OUTPUT FILE NO. 13"
1008 IFC1=12THENH1=9
1009 IFC1=11THENH1=10
1020 FORI=1TO96
1021 IFA(13,I)=0THEN1030
1022 A(H1,I)=(A(C1,I)/A(13,I))*A(14,I)
1028 PRINTI"      "A(H1,I)
1030 NEXT

```

```

1032 FORU=1TO1000:NEXT
1034 A$(H1,1)=MID$(STR$(H1),2)
1035 A$(H1,3)="96"
1036 A$(H1,2)="RESP-"+MID$(STR$(H1),2)
1037 A$(H1,4)="CUT ONE CALC OF RESPONSE OF DETECTOR"
1040 B$(1)=" = FILE NUMBER"
1041 B$(2)=" = FILE NAME"
1042 B$(3)=" = DATA ITEMS IN FILE"
1060 PRINT"FILE HEADER : "
1061 FORI=1TO8
1062 PRINTI" "A$(H1,I)" " "B$(I)
1064 NEXT
1068 S=0:INPUT"CHANGE LINE";S
1069 IFS>0THEN1071
1070 GOTO100
1071 K$="":INPUT"MAKE CHANGE";K$
1072 IFK$>" "THENA$(H1,S)=K$
1073 GOTO1060

```

```

1100 PRINTCHR$(147)"***** EDIT FILE HEADER *****"
1102 PRINT:PRINT
1104 C$(1)="[[[FILE NUMBER]]]";C$(2)="[[[FILE NAME]]]"
1105 C$(3)="[[[FILE LENGTH]]]";C$(4)="[[[TYPE OF DATA]]]"
1106 C$(7)="":C$(8)=" "
1107 C$(5)="[[[RESERVED FOR COMPUTER ENTRY]]]"
1108 C$(6)="[[[OPERATOR NOTES]]]"
1110 L=0:INPUT"ENTER FILE NUMBER";L
1120 FORI=1TO8
1121 PRINTC$(I)
1122 PRINTI" "A$(L,I)
1124 NEXT
1130 L8=0:INPUT"CHANGE LINE";L8
1132 IFL8>0THEN1140
1134 GOTO100
1140 LL$="":INPUT"MAKE CHANGE ";LL$
1142 A$(L,L8)=LL$
1146 GOTO1120

```

```

1206 REM ***** FILE NUMBER LIST *****
1208 PRINT"ENTER 11 FOR TOP DET. DATA"
1209 PRINT"ENTER 12 FOR BOT DET. DATA"
1210 PRINT"ENTER 13 FOR EG&G DET. DATA"
1211 PRINT"ENTER 14 FOR EG&G DET. MFG.RESP."
1212 PRINT"ENTER 15 FOR TOP DET. MFG.RESP."
1213 PRINT"ENTER 16 FOR BOT DET. MFG.RESP."
1214 PRINT"ENTER 17 FOR TOP DET. + LIGHT PIPE DATA"
1215 PRINT"ENTER 18 FOR BOT DET. + LIGHT PIPE DATA"
1219 PRINT
1230 RETURN

```

```

1280 PRINTCHR$(147)"***** DISK
1281 PRINT:PRINT:PRINT:PRINT
1282 OPEN#15,8,15
1283 INPUT#15,A$,B$,C$,D$
1284 CLOSE#15
1286 PRINTA$,B$,C$,D$
1288 INPUT"MENU ON C.R. ";%
1290 B$="":GOTO100

```

```

1600 REM ***** LIST OF FILES *****
1604 PRINT:PRINT"FILE 1 - TOP DET RESP"
1605 PRINT"FILE 2 - BOT DET RESP"
1606 PRINT"FILE 3 - LIGHT PIPE RESP"
1607 PRINT"FILE 4 - MISC. A"
1608 PRINT"FILE 5 - MISC. B"
1609 PRINT"FILE 6 - MISC. C"
1610 PRINT"FILE 7 - BOT DET INTERMEDIATE CALC #2"
1611 PRINT"FILE 8 - TOP DET INTERMEDIATE CALC #2"
1612 PRINT"FILE 9 - BOT DET INTERMEDIATE CALC #1"

```

```
1613 PRINT"FILE 10 - TOP DET INTERMEDIATE CALC #1"
1614 PRINT"FILE 11 - TOP DET DATA"
1615 PRINT"FILE 12 - BOT DET DATA"
1616 PRINT"FILE 13 - EG&G DET DATA"
1617 PRINT"FILE 14 - EG&G MFG. RESP."
1618 PRINT"FILE 15 - TOP DET MFG. RESP. DATA"
1619 PRINT"FILE 16 - BOT DET MFG. RESP. DATA"
1620 PRINT"FILE 17 - TOP DET - LIGHT PIPE DATA"
1621 PRINT"FILE 18 - BOT DET - LIGHT PIPE DATA"
1629 RETURN
```

```
2099 REM *** ASSIGN TITLE TO FILE HEADER ***
2100 IFL$="11"THEN A$(L,4)="TOP DET DATA"
2102 IFL$="12"THEN A$(L,4)="BOT DET DATA"
2103 IFL$="13"THEN A$(L,4)="EG&G DET DATA"
2104 IFL$="14"THEN A$(L,4)="EG&G MFG. RESP CURVE"
2105 IFL$="15"THEN A$(L,4)="TWO COLOR DET * TOP * MFG. RESP. DATA"
2106 IFL$="16"THEN A$(L,4)="TWO COLOR DET * BOT * MFG. RESP. DATA"
2107 IFL$="17"THEN A$(L,4)="TOP DET. ** LIGHT PIPE DATA "
2108 IFL$="18"THEN A$(L,4)="BOT DET. ** LIGHT PIPE DATA "
2120 RETURN
```



PROGRAM 'RESP-96D' - 12/09/85 - REMARKS

THE MAIN FUNCTIONS OF THE PROGRAM ARE:  
INPUT DATA.  
SAVE DATA ON DISK.  
PRINT DATA ON PAPER.

SOME OF THE MATH OPERATIONS ARE BEST DONE IN THE IMMEDIATE MODE.  
AN EXAMPLE IS THE PRODUCT OF TWO TABLES:

```
FORI=1T096:A(5,I)=A(13,I)*A(14,I):NEXT
```

THE SUPPORT PROGRAMS ARE USED TO OPERATE THE I/O PORT.  
MADE FOR A SET OF 18 FILES. SOME ARE LISTED STARTING AT LINE  
1600 IN THE PROGRAM.

EACH FILE MUST HAVE A DIFFERENT NAME. WHEN A FILE IS INPUT FROM  
WHEN RUN THESE PROGRAMS DISPLAY A LIST OF REM STATEMENTS FOR MAIN  
PROGRAMS #1 #2 & #3.  
THE REM PROGRAMS CAN BE LISTED OR RUN.  
WHEN RUN THE PROGRAM GIVES THE OPTION OF DISPLAY OR HARD COPY.

ALL FILES ARE SEQUENTIAL STARTING WITH A HEADER 8 LINES LONG  
FOLLOWED BY A 96 LINE DATA SET  
LINES 3 THROUGH 8 OF THE HEADER MAY BE USED FOR USER NOTES.  
LINE 4 IS RESERVED FOR PROGRAM USE.  
LINE 3 INDICATES THE NUMBER OF DATA ITEMS IN THE FILE.  
LINE 2 IS THE FILE NAME.  
LINE 1 IS THE FILE NUMBER - (STORAGE LOCATION IN THE PROGRAM).

WAVELENGTH - IS RELATED TO DATA LINE NUMBER AS FOLLOWS:  
 $W2=0.3+(.01*(I-1))$  WHERE I IS THE LINE NUMBER.

WHEN ENTERING DATA TWO ENTRIES ARE ASKED FOR:  
1 - SCALE IN VOLTS PER INCH  
2 - READING IN INCHES  
THIS SCHEME IS INTENDED TO FACILITATE ENTRY OF GRAPHED DATA.

IF AN INCORRECT ENTRY HAS BEEN MADE - ENTER THE CHARACTER 'E' IN  
PLACE OF THE NEXT ENTRY.  
THE PROGRAM WILL ASK FOR THE NUMBER OF THE ENTRY TO BE CORRECTED.

IT MAY BE EASIER TO MAKE CORRECTIONS WHILE IN THE EDIT FUNCTION.

\*\*\*\*\* CALCULATION OF DETECTOR RESPONSE \*\*\*\*\*

ASSUMPTIONS:

FILE 13 IS THE OUTPUT OF A SPECTROMETER AS READ BY A REFERENCE DETECTOR.

FILES 11 & 12 IS THE OUTPUT OF THE SPECTROMETER AS READ BY TOP AND THE BOTTOM DETECTOR.

FILE 14 IS THE SPECTRAL RESPONSE CURVE OF THE REFERENCE DET.

THE CALCULATION IS AS FOLLOWS:

$((\text{TOP}(\text{OR BOT.})\text{DET})/(\text{REF DET.})) * (\text{REF DET RESPONSE})$

$((\text{FILE 11})/(\text{FILE 13})) * \text{FILE 14}$

SEE LINE 1022

FILE NUMBERS:

IF THE SOURCE FILE IS NO. 11 THEN THE DESTINATION FILE IS NO.10

IF THE SOURCE FILE IS NO. 12 THEN THE DESTINATION FILE IS NO.9

\*\*\*\*\* TABLE OF FILE NUMBER ASSIGNMENTS \*\*\*\*\*

- 1 TOP DET. - NORMALIZED SPECTRAL RESPONSE.
- 2 BOT DET. - NORMALIZED RESPONSE.
- 3 NOT ASSIGNED.
- 4 LIGHT PIPE - NORMALIZED RESPONSE.
- 5 NOT ASSIGNED.
- 6 NOT ASSIGNED.
- 7 NOT ASSIGNED.
- 8 LIGHT PIPE TRANSMISSION.
- 9 BOT DET. - CALCULATED SPECTRAL RESPONSE.
- 10 TOP DET. - CALCULATED SPECTRAL RESPONSE.
- 11 TOP DET. - OUTPUT OF SPECTROMETER.
- 12 BOT DET. - OUTPUT OF SPECTROMETER.
- 13 REFERENCE DET. - OUTPUT OF SPECTROMETER.
- 14 REFERENCE DET. - SPECTRAL RESPONSE - MANUFACTURERS CAL.
- 15 TOP DET. - SPECTRAL RESPONSE - MANUFACTURERS CAL.
- 16 BOT DET. - SPECTRAL RESPONSE - MANUFACTURERS CAL.
- 17 DATA - TOP DET. READING SPECT. OUTPUT THRU LIGHT PIPE.
- 18 DATA - BOT DET. READING SPECT. OUTPUT THRU LIGHT PIPE.

NOTE: SUFFIX 'N' ON A FILE INDICATES NORMALIZED DATA.

GOTO8000  
 3 PROGRAM RESP-96D-R3

10/27/85

4 . THE FOLLOWING REMARKS ARE BY LINE NUMBERS WHICH  
 5 . CORRESPOND TO THOSE IN THE PROGRAM.  
 6 .

10 DIMENSION FOR 18 FILES OF 100 ITEMS EACH  
 16 GOTO MAIN MENU. BYPASS LINES 18 THRU 27.  
 18 .  
 20 . . SETS ALL VALUES OF ALL .  
 21 . . 18 TABLES TO 1.0 . .  
 22 . .  
 24 . . EACH TABLE IS A FILE. .  
 26 . .  
 27 . .

100 . \*\*\*\*\* MAIN MENU \*\*\*\*\*  
 102 .  
 104 .  
 106 .  
 108 .  
 110 .  
 112 .  
 114 .  
 115 .  
 116 .  
 117 .  
 118 . ↑↑↑↑↑↑↑↑ END OF MENU ↑↑↑↑↑↑↑↑  
 130 .  
 132 CHECK THAT COMMAND IS WITHIN LIMITS.  
 134 . ↑ ↑ ↑ ↑ ↑  
 136 STARTING ADDRESSES OF MENU ITEMS.

200 . \*\*\*\*\* MANUAL INPUT OF DATA \*\*\*\*\*  
 202 .  
 206 .  
 208 SUBROUTINE DISPLAYS FILE NUMBERS AND NAMES.  
 209 .  
 210 ENTER FILE NUMBER.  
 211 CHECK THAT FILE NO. IS WITHIN LIMITS.  
 212 ENTER UNIQUE NAME OR CODE DESCRIPTION.  
 213 INIT TABLE ONLY TO ERASE PREVIOUS FDATA IN FILE.  
 214 PUTS DATA TYPE IN HEADER LINE #4 FOR FILES 11 THRU 18.  
 216 LOADS FILE HEADER LINES 1, 2, & 3.  
 217 SKIP NEXT LINE IF FILE INIT NOT WANTED.  
 218 SET ALL VALUES TO ZERO.  
 219 SELECT SUBSCRIPT OF STARTING ENTRY.  
 220 .  
 221 .  
 222 .  
 223 .  
 224 .  
 225 .  
 226 P IS THE STARTING SUBSCRIPT.  
 229 VALUE IS A RAW READOUT ENTRY.  
 230 CHECK TO SEE IF ENTRY IS A REQUEST FOR A CORRECTION.  
 231 SCALE IS A MULTIPLIER OR CONVERSION NUMBER.  
 232 CHECK TO SEE IF ENTRY IS A REQUEST FOR A CORRECTION.  
 233 IF VALUE NOT ENTERED - SKIP TABLE ENTRY AND PRINT TABLE CONTENTS.  
 234 CALC. WAVELENGTH  
 235 CALC "ENTRY"  
 237 ENTER DATA INTO TABLE.  
 238 DISPLAY SUBSCRIPT  
 239 DISPLAY VALUE (ON ABOVE LINE). "J" IS CRSR UP .  
 240 DISPLAY VALUE (ON ABOVE LINE). "J" IS CRSR UP .  
 242 DISPLAY SCALE  
 243 DISPLAY  
 248 .  
 249 DELAY TO PERMIT READING OF LAST ENTRY.  
 250 GOTO MAIN MENU.  
 254 SKIP CORRECTION ROUTINE IF SUBSCRIPT NOT SPECIFIED.  
 256 SET P = TO LINE NUMBER TO BE CORRECTED.  
 258 ESCAPE TO MENU IF DESIRED.  
 259 .  
 260 CLEAR SCREEN.

261 \*\*\*\*\* EDIT DATA FILE \*\*\*\*\*  
262 SELECT ANOTHER FILE IF WANTED.  
263 CHECK INPUT.  
264 INPUT STARTING SUBSCRIPT (LINE NUMBER).  
265 .  
266 DISPLAY 10 LINES OF FILE.  
267 .  
268 CHECK FOR END OF FILE.  
269 .  
270 ENTER NUMBER OF LINE TO BE CHANGED.  
271 .  
272 BOTTOM OF DISPLAY. CHECK FOR VALID LINE NUMBER.  
273 TOP OF DISPLAY.  
274 .  
275 CHANGE VALUE ONLY IF ENTRY HAS BEEN MADE.  
276 .  
277 CHANGE VALUE ONLY IF ENTRY HAS BEEN MADE.  
278 RECALCULATE "ENTRY"  
279 DISPLAY NEW VALUES IF ENTRY HAS BEEN MADE.  
280 DISPLAY NEW VALUES IF ENTRY HAS BEEN MADE.  
281 .  
282 .  
283 SET UP TO DISPLAY NEXT SET OF LIST.  
284 .  
288 GOTO MAIN MENU.

400 \*\*\*\*\* NORMALIZE DATA FILE \*\*\*\*\*  
402 .  
404 NUMBER OF FILE TO BE NORMALIZED.  
405 NUM. OF FILE THAT WILL BE THE NORMALIZED VERSION.  
406 .  
407 .  
410 .  
420 .  
422 ESCAPE IF DESIRED.  
424 .  
430 INIT "MAX. VAL."  
432 .  
434 SEARCH FOR MAX. VAL.  
436 .  
438 .  
440 .  
450 NORMALIZE TABLE.  
452 .  
454 .  
460 PUT FILE NUM. IN HEADER LINE #1.  
462 ADD "-N" TO FILENAME IN HEADER LINE #2.  
464 ENTER NUM. OF ENTRIES IN NEW FILE.  
466 SET HEADER LINE #4 OF NEW FILE = TO OLD FILE.  
470 .  
472 TIME DELAY.

500 \*\*\*\*\* DIVISION OF FILES \*\*\*\*\*  
502 .  
504 .  
506 .  
508 .  
509 .  
510 .  
511 .  
512 .  
513 LINE #4 OF NEW FILE HEADER TELLS WHERE DATA CAME FROM.  
514 ESCAPE IF DESIRED.  
516 .  
520 START DIVISION ROUTINE.  
522 .  
524 PREVENT DIVISION BY ZERO ERROR.  
526 DIVISION.  
528 DISPLAY RESULT.  
530 .  
532 TIME DELAY.  
540 GOTO MAIN MENU.

550 .  
552 .  
554 .  
556 ESCAPE IF DESIRED.  
558 .  
566 START RECIPRICAL ROUTINE.  
567 .  
568 PREVENT DIVISION BY ZERO.  
569 .  
572 .  
574 .  
578 .  
579 INPUT DESTINATION FILE HEADER.  
580 GOTO MAIN MENU.

600 \*\*\*\*\* SAVE FILE ROUTINE \*\*\*\*\*  
601 PRINTPRINTPRINTPRINTPRINT  
602 DISPLAY LIST OF FILES.  
620 FILE NUM. TO BE SAVED.  
622 .  
631 .  
632 .  
633 DISPLAY FILE NAME.  
634 .  
636 .  
637 DISPLAY FILE HEADER.  
638 .  
639 .  
640 EDIT HEADER LINE OPTION.  
641 .  
642 EDIT LINE. THEN REDISPLAY HEADER.  
643 ESCAPE IF DESIRED.  
646 IF FILE OF SAME NAME IS ON DISK - DELETE IT.  
647 .  
648 ASSEMBLE FILE NAME.  
649 GET FILE NUMBER AS INT.  
650 OPENCOMMAND CHANNEL ON DISK.  
651 OPEN FILE.  
652 READ DISK STATUS CODES.  
653 IF NO PROBLEM - CONTINUE  
654 IF PROBLEM -. DISPLAY IT AND CLOSE FILES.  
655 START OVER.  
657 SAVE FILE HEADER.  
658 ADD CHARACTER TO EACH STRING IN CASE OF NULL STRING.  
659 .  
665 START DATA SAVE.  
667 .  
668 DISPLAY DATA.  
669 .  
670 END OF FILE MARKER.  
672 CLOSE FILES.  
674 GOTO MAIN MENU.  
680 DELETE FILE ROUTINE.  
682 DELETE FILE ROUTINE.  
684 GOTO SAVE FILE ROUTINE.  
690 CLEAR ERROR MESSAGE - GOTO MAIN MENU.

700 \*\*\*\*\* GET FILE FROM DISK ROUTINE \*\*\*\*\*  
702 .  
703 PRINT LIST OF FILES.  
704 ENTER FILE NUM. TO BE LOADED (FROM DISK)  
705 .  
706 ESCAPE IF DESIRED.  
707 .  
710 ASSEMBLE FILE NAME.  
718 OPEN ERROR CHANNEL.  
720 OPEN FILE.  
721 READ DISK STATUS.  
722 IF NO ERROR, CONTINUE LOAD.  
723 DISPLAY ERROR.  
724 CLOSE FILES - GOTO MAIN MENU.

725 INPUT FILE HEADER FOR INSPECTION  
726 FIRST CHAR. IN STRING IS NOT REMOVED SO THAT NULL STRINGS ARE OBVIOUS.  
727 .  
728 .  
730 CLOSE FILE.  
732 CHECK FILE NUMBER.  
734 CHECK NUMBER OF ITEMS IN FILE.  
740 ESCAPE IF DESIRED.  
741 .  
750 INPUT HEADER.  
753 .  
754 REMOVE FIRST CHAR. OF STRING.  
755 .  
760 INPUT DATA.  
762 .  
764 .  
766 .  
770 CLOSE FILE AND COMMAND CHAN.  
771 DELAY.  
790 INIT ERROR MESSAGE - GOTO MAIN MENU.

800 \*\*\*\*\* HARD COPY OF FILE \*\*\*\*\*802 .  
804 DISPLAY LIST OF FILES.  
806 USED BELOW.  
807 USED BELOW.  
808 USED BELOW.  
810 FILE TO BE PRINTED.  
812 CAN START AT SUBSCRIPT OTHER THAN ONE.  
820 OPEN PRINTER.  
830 .  
832 .  
833 LINES.  
834 PRINT DESCRIPTION OF FILE.  
836 .  
838 PRINT DATA.  
840 LINE -- WAVELENGTH -- VALUE.  
845 .  
848 CLOSE PRINTER.  
850 GOTO MAIN MENU.

900 \*\*\*\*\* CALC LIGHT PIPE TRANS. \*\*\*\*\*  
902 .  
904 .  
905 .  
910 INPUT ONE OF ABOVE TWO SOURCE FILES - DETECTOR OUTPUT THROUGH FIBER.  
911 INPUT FILE NO. FO DETECTOR USED FOR ABOVE MEAS.  
920 INPUT FILE HEADER INFO.  
922 INPUT FILE HEADER INFO.  
923 INPUT FILE HEADER INFO.  
924 INPUT FILE HEADER INFO.  
926 INPUT FILE HEADER INFO.  
940 CALCULATE TRANSMISSION.  
942 .  
944 .  
946 .  
962 GOTO MAIN MENU.

1000 \*\*\* FIRST STEP CALC. OF DET. RESPONSE \*\*\*  
1002 .  
1004 .  
1005 CALCULATION TO BE MADE.  
1006 .  
1008 ESTABLISH DESTINATION FILE.  
1009 ESTABLISH DESTINATION FILE.  
1020 CALC RESPONSE.  
1021 .  
1022 .  
1028 DISPLAY RESULT.  
1030 .

1032 TIME DELAY TO VIEW LAST NUM.  
1034 INPUT TO DESTINATION HEADER.  
1035 INPUT TO DESTINATION HEADER.  
1036 INPUT TO DESTINATION HEADER.  
1037 INPUT TO DESTINATION HEADER.  
1040 DISPLAY INFO.  
1041 DISPLAY INFO.  
1042 DISPLAY INFO.  
1060 DISPLAY DESTINATION FILE HEADER.  
1061 .  
1062 .  
1064 .  
1068 EDIT HEADER OPTION.  
1069 .  
1070 GOTO MAIN MENU  
1071 CHANGE CONTENTS OF LINE.  
1072 IF LINE HAS BEEN CHANGED - ENTER NEW CONTENTS.  
1073 REDISPLAY FILE HEADER.

1100 \*\*\*\*\* EDIT ANY FILE HEADER \*\*\*\*\*  
1102 CREATE HEADER DISPLAY TITLES.  
1104 . "H" IS COLOR CHANGE - CTRL 6  
1105 . PRINTPRINT  
1106 .  
1107 .  
1108 .  
1110 .  
1120 DISPLAY HEADER.  
1121 . LINE TITLE.  
1122 . HEADER LINE CONTENT.  
1124 .  
1130 .  
1132 .  
1134 IF NO LINE INDICATED ABOVE, GOTO MAIN MENU.  
1140 CHANGE LINE.  
1142 .  
1146 REDISPLAY HEADER.

1206 \*\*\* SUBROUTINE TO DISPLAY LIST OF FILES. \*\*\*  
1208 .  
1209 .  
1210 .  
1211 .  
1212 .  
1213 .  
1214 .  
1215 .  
1219 .  
1250 .

1281 \*\*\* ROUTINE TO CHECK DISK ERROR CODE \*\*\*  
1282 OPEN COMMAND CHANNEL.  
1283 READ CODES.  
1284 CLOSE CHANNEL.  
1286 DISPLAY STATUS INFO.  
1288 . HOLDS DISPLAY UNTIL READY TO GO ON.  
1290 CLEAR STATUS MESSAGE. - GOTO MAIN MENU.

1600 .  
1604 .  
1605 .  
1607 .  
1608 .  
1609 .  
1610 .  
1611 .  
1612 .

1613 .  
1614 .  
1615 .  
1617 .  
1618 .  
1619 .  
1620 .  
1621 .  
1629 .

2099 .  
2100 .  
2102 .  
2103 .  
2104 .  
2105 .  
2106 .  
2107 .  
2108 .  
2120 .

```
5001 PRINTPRINTPRINT
8000 PRINTCHR$(147):PRINT:PRINT:PRINT:PRINT
8001 PRINT"REMARKS FOR PROGRAM RESP-96D"
8002 H$="":PRINT:PRINT:PRINT:INPUT"HARD COPY IF Y ";H$
8003 IF H$="Y"THEN8050
8010 LIST
8015 END
8050 PRINT:PRINT
8052 PRINT"PLEASE CLOSE PRINTER WHEN LIST IS FINISHED"
8055 OPEN4,4,0:CMD4
8060 PRINT "***** REMARKS FOR PROGRAM RESP-96D *****"
8062 PRINT:PRINT"          10/27/85"
8070 PRINT:PRINT"THE FOLLOWING REMARKS ARE BY LINE NUMBERS WHICH"
8072 PRINT"CORRESPOND TO THOSE IN THE PROGRAM."
8075 PRINT:PRINT:PRINT
8080 LIST
```



APPENDIX D2

COMPUTER PROGRAM WAT-CA96D

```

2 REM ** WAT-CA96F ** REV. 12/09/65
3 PRINTCHR$(147)"INITIALIZING FILE AREA-----PLEASE WAIT"
5 REM CHANGED TO PERMIT DATA TABLES OF 99 ITEMS (WAVELENGTHS)
6 REM CHANGED TO PERMIT QUICK CHANGE OF CONSTANTS
7 REM BETTER HEADER EDITING ADDED
10 DIM DT(8,100),A$(8,8),B$(2,8),CC(2,85)
50 ZZ$=""
100 PRINTCHR$(147):PRINT
101 PRINT" PROBLEM ?? - TO PREVENT LOSS OF DATA RESTART WITH GOTO100"
102 PRINT:PRINT:PRINTZZ$:PRINT

```

```

103 PRINTTAB(8)"***** MAIN MENU *****":PRINT:PRINT
104 PRINTTAB(6)"1 - CALC. SYSTEM OUTPUT"
105 PRINTTAB(6)"2 - CALC. COMPOSIT RESP."
106 PRINTTAB(6)"3 - EDIT"
107 PRINTTAB(6)"4 - SAVE TO DISK"
108 PRINTTAB(6)"5 - INPUT FROM DISK"
109 PRINTTAB(6)"6 - KEYBOARD INPUT COMPONENT DATA"
110 PRINTTAB(6)"7 - PRINT TABLE DATA"
111 PRINTTAB(6)"8 - DISK DIRECTORY"
113 PRINTTAB(6)"11 - SYSTEM OUTPUT TIMES CONSTANT"
114 PRINT:PRINT:PRINTTAB(15);
115 INPUT"COMMAND ";K:IFK<1THEN100
116 IFK>11THEN100
118 ONKGOTO400,200,1000,800,1200,600,1400,130,100,1500,2400
130 GOSUB2006
131 INPUT"CONT. ON C.R. ";X
132 GOTO100
200 PRINTCHR$(147)

```

```

201 PRINT:PRINT"*** CALCULATE COMPOSIT RESPONSE ***"
202 PRINT
204 PRINT:PRINT
209 D1=0:D2=0:D3=0:D4=0:D5=0:D6=0
210 K$="":INPUT"USE DETECTOR RESPONSE IF Y ";K$:PRINT
211 IFK$="Y"THEND1=1:D2=1
214 K$="":INPUT"USE LIGHT PIPE RESP IF Y ";K$:PRINT
215 IFK$="Y"THEND3=1
218 K$="":INPUT"USE UPPER DET. TRIM IF Y ";K$:PRINT
219 IFK$="Y"THEND5=1
222 K$="":INPUT"USE LOWER DET. TRIM IF Y ";K$:PRINT
223 IFK$="Y"THEND6=1
226 K$="":INPUT"USE SYSTEM RESPONSE IF Y ";K$
227 IFK$="Y"THEND4=1
228 PRINT"D1="D1" D2="D2" D3="D3" D4="D4" D5="D5" D6="D6
240 PRINT:K$="":INPUT"MAKE CHANGES IF Y ";K$
241 IFK$="Y"THEN200
242 PRINT:PRINT:PRINT:PRINT
252 PRINT"* CALCULATING COMPOSIT RESPONSE CURVES *"
255 A$(7,4)="D1="+STR$(D1)+" D3="+STR$(D3)+" D4="+STR$(D4)+" D5="+STR$(D5)
256 A$(8,4)="D2="+STR$(D2)+" D3="+STR$(D3)+" D4="+STR$(D4)+" D6="+STR$(D6)
257 GOTO312
260 PRINTCHR$(147)"PRESENT FILE NAME IS "A$(K,2)
264 PRINT:PRINT
266 FORI=1TO8:PRINTI" "A$(K,I):NEXT
268 L=0:INPUT"CHANGE LINE ";L
269 IFL=0THENRETURN
270 PRINTA$(K,L)
271 K$="":INPUT" CHANGE TO ";K$
272 IFK$=""THENA$(K,L)=K$:GOTO260
274 RETURN
280 PRINTCHR$(147)"PRESENT FILE NAME IS "B$(0,2)
284 PRINT:PRINT
286 FORI=1TO8:PRINTI" "B$(0,I):NEXT
288 L=0:INPUT"CHANGE LINE ";L
289 IFL=0THENRETURN
290 PRINTB$(0,L)
291 K$="":INPUT" CHANGE TO ";K$
292 IFK$=""THENB$(0,L)=K$:GOTO280
294 RETURN

```

```

312 FORI=1T096
313 DT(7,I)=1
314 DT(8,I)=1
315 NEXT
320 FORI=1T096
323 IFD1=1THENDT(7,I)=DT(7,I)*DT(1,I)
325 IFD3=1THENDT(7,I)=DT(7,I)*DT(3,I)
327 IFD4=1THENDT(7,I)=DT(7,I)*DT(4,I)
329 IFD5=1THENDT(7,I)=DT(7,I)*DT(5,I)
330 PRINTI"  "DT(7,I)
331 FORL=1T0100:NEXT
332 NEXT
333 PRINT"UPPER DET. CALC. COMPLETE"
340 FORI=1T096
343 IFD2=1THENDT(8,I)=DT(8,I)*DT(2,I)
345 IFD3=1THENDT(8,I)=DT(8,I)*DT(3,I)
347 IFD4=1THENDT(8,I)=DT(8,I)*DT(4,I)
349 IFD6=1THENDT(8,I)=DT(8,I)*DT(6,I)
350 PRINTI"  "DT(8,I)
351 FORL=1T0100:NEXT
352 NEXT
353 PRINT"LOWER DET. CALC. COMPLETE"
355 FORL=1T01000:NEXT
360 ZZ$="COMPOSIT RESP. CURVES COMPLETE"
370 GOTO100

```

```

400 REM
401 PRINTCHR$(147)
402 PRINT:PRINT"*** CALCULATE SYSTEM OUTPUT CURVE ***"
403 PRINT:PRINT"DEFAULT VALUES:"
410 PRINT"STARTING TEMP. = 340 DEG. C"
411 PRINT"INTERVAL = 20 DEG. C (MINIMUM VAL.)"
412 PRINT:PRINT"ENDING TEMP = 2000 DEG. C"
413 PRINT:PRINT
416 TS=340:INPUT"ENTER STARTING TEMP. ";TS
417 PRINT:TD=20:INPUT"ENTER INCREMENT";TD
418 IFTD<20THENPRINT"USE VALUE GREATER THAN 20 ":GOTO417
419 PRINT:TE=2000:INPUT"ENTER ENDING TEMP. ";TE
420 PRINT:X7=7.114E-07:PRINT"TOP DET CONSTANT = "X7
421 INPUT"CHANGE TO ";X7
422 PRINT:X8=1.4423E-07:PRINT"BOT DET CONSTANT = "X8
423 INPUT"CHANGE TO ";X8
424 PRINT:PRINT"W9=.30 ":W9=.30:INPUT"CHANGE WAVELENGTH TO ";W9
425 PRINT:PRINT"K9=1 ":K9=1:INPUT"CHANGE CONSTANT MULT FACTOR TO ";K9
428 L=0:M=1
429 B$(0,3)="84":B$(0,4)=STR$(TS):B$(0,5)=STR$(TD):B$(0,6)=STR$(TE)
430 R=1
431 PRINT:L$="":INPUT"ENTER Y FOR PRINTOUT ";L$
432 X9=0:IFL$="Y"THENX9=4
434 IFX9=4THENOPEN4,4,0
435 PRINT"CREATING TABLE - PLEASE BE PATIENT"
436 C1=37418
437 C2=14387.9
438 GOSUB560
439 IFX9=4THENGOSUB502
440 T=TS
441 K=T+273.15
442 REM WA=TOP DET  WB=BOT DET.  W9=STARTING WAVELENGTH
443 REM ORIGINAL CONSTANT IN LINE 452 WAS 7.114E-07
444 REM CALC AMPS FOR EACH 0.1 MICRION WAVELENGTH INCREMENT
445 WT=0:WU=0
446 S7=.01*X7*K9:S8=.01*X8*K9
447 REM SPEED CALC  COMBINE CONSTANTS
448 FORD=1T096
449 Y=W9+(D-1)*.01
450 WX=(C1/Y15)/((EXP(C2/(Y*K))) - 1)
452 WA=WX*DT(7,D)*S7
453 WB=WX*DT(8,D)*S8
454 WT=WT+WA
455 WU=WU+WB
456 NEXT

```

```

458 CC(0,R)=WT
460 CC(1,R)=WU
467 IFX9=4THENGOSUB550
468 GOSUB570
474 IFT=TETHEN482
475 IFT>TETHEN482
478 T=T+TD
479 R=R+1
480 GOTO441
482 ZZ$="OUTPUT CURVES COMPLETE"
484 IFX9=4THENPRINT#4:CLOSE4
485 INPUT"CONTINUE ON C.R. ";WW:GOTO100:REM ALT TO LINE 484
490 IFI=0THENJ=7
492 IFI=1THENJ=8
494 RETURN

```

```

500 REM
502 PRINT#4,"SYSTEM OUTPUT CURVES":PRINT#4
504 PRINT"PREVIOUS FILE NAME="B$(L,2)
506 K$="":INPUT"ENTER NEW FILE NAME ";K$
507 L$="":INPUT"IF NOT OK ENTER N ";L$
508 IFL$="N"THEN506
509 IFK$=""THENK$=B$(0,2)
510 B$(0,2)=K$:B$(0,1)="0CC"
511 PRINT#4,TAB(5)"SOURCE FILES="A$(7,2)A$(8,2):PRINT
512 PRINT#4,"2 FILE NAME:"B$(0,2):PRINT#4
513 PRINT#4," COLUMN "VAL(B$(0,1))" "B$(0,3)" LINES START AT "B$(0,4);
514 PRINT#4," DELTA T "B$(0,5)" STOP AT "B$(0,6)
515 PRINT#4,"7 "B$(0,7):PRINT#4,"8 "B$(0,8)
516 PRINT#4
517 PRINT#4,"TOP DET CONSTANT (X7)="X7:PRINT#4,"BOT DET CONSTANT (X8)="X8
518 PRINT#4,"STARTING WAVELENGTH="W9" SYSTEM CONSTANT K9="K9
519 PRINT#4
520 PRINT#4,CHR$(27)CHR$(16)CHR$(0)CHR$(000)"TEMPERATURE ";
521 PRINT#4,CHR$(27)CHR$(16)CHR$(0)CHR$(100)"PHOTOCURRENT";
522 PRINT#4,CHR$(27)CHR$(16)CHR$(0)CHR$(230)"PHOTOCURRENT"
523 PRINT#4,CHR$(27)CHR$(16)CHR$(0)CHR$(000)"DEGREES C ";
524 PRINT#4,CHR$(27)CHR$(16)CHR$(0)CHR$(100)"AMPERES * TOP";
525 PRINT#4,CHR$(27)CHR$(16)CHR$(0)CHR$(230)"AMPERES * BOT";
526 PRINT#4,CHR$(27)CHR$(16)CHR$(1)CHR$(100)"RATIO"
527 PRINT#4
528 RETURN
550 PRINT#4,CHR$(27)CHR$(16)CHR$(0)CHR$(000)T;
551 PRINT#4,CHR$(27)CHR$(16)CHR$(0)CHR$(100)CC(0,R);
552 PRINT#4,CHR$(27)CHR$(16)CHR$(0)CHR$(230)CC(1,R);
553 PRINT#4,CHR$(27)CHR$(16)CHR$(1)CHR$(100)CC(0,R)/CC(1,R)
554 RETURN
560 PRINT" T TOP I BOT I RATIO"
561 RETURN
562 PRINT
564 RETURN
570 PRINTT" "CC(0,R)" "CC(1,R)" "CC(0,R)/CC(1,R)
572 PRINT
574 RETURN

```

```

600 PRINTCHR$(147)
602 PRINTTAB(3)"***** DATA TABLE MENU *****"
604 PRINT:PRINT
606 PRINTTAB(5)"1 - UPPER DETECTOR RESPONSE"
607 PRINTTAB(5)"2 - LOWER DETECTOR RESPONSE"
608 PRINTTAB(5)"3 - LIGHT PIPE RESPONSE"
609 PRINTTAB(5)"4 - SYSTEM RESPONSE"
610 PRINTTAB(5)"5 - TRIM CURVE - UPPER DET."
611 PRINTTAB(5)"6 - TRIM CURVE - LOWER DET."
612 PRINTTAB(5)"7 - INPUT FROM DISK":PRINT
613 PRINTTAB(5)"8 - EDIT DATA"
615 PRINT
616 PRINTTAB(5)"9 - MAIN MENU"
624 PRINT
626 PRINTTAB(5)"10 - SAVE DATA ON DISK"
628 PRINT:PRINT:K=0
630 PRINTTAB(12);:INPUT"COMMAND ";K

```

```

631 IFK=0THEN600
632 IFK>10THEN600
633 PRINTCHR$(147):PRINT:PRINT
634 ONKGOTO651,653,655,657,659,661,1200,1000,100,800
651 PRINT"ENTER RESPONSE OF UPPER DETECTOR":A$(K,4)="TOP DET RESP"
652 A$(1,1)="1":GOTO700
653 PRINT"ENTER RESPONSE OF LOWER DETECTOR":A$(K,4)="BOT DET RESP"
654 A$(2,1)="2":GOTO700
655 PRINT"ENTER TRANSMISSION OF LIGHT PIPE":A$(K,4)="FIBER TRANS"
656 A$(3,1)="3":GOTO700
657 PRINT"ENTER SYSTEM RESPONSE":A$(K,4)="SYSTEM RESP"
658 A$(4,1)="4":GOTO700
659 PRINT"ENTER UPPER DET. TRIM CURVE":A$(K,4)="TOP DET TRIM"
660 A$(5,1)="5":GOTO700
661 PRINT"ENTER LOWER DET. TRIM CURVE":A$(K,4)="BOT DET TRIM"
662 A$(6,1)="6":GOTO700
700 PRINT:PRINT
710 I=1
712 PRINT"I="I" "DT(K,I)" ";:Y=0:INPUT"NEW VALUE = ";Y
714 IFY>0THENDT(K,I)=Y
716 L$="":INPUT"MENU IF Y ";L$:IFL$="Y"THEN790
718 PRINT
720 I=I+1
721 IFI>96THEN100
722 GOTO712
790 Q=0:INPUT"RESTART AT I= ";Q
791 IFQ=0THEN600
792 IFQ>0THENI=Q
794 GOTO712
798 GOTO600

```

```

800 PRINTCHR$(147)
801 PRINT"***** SAVE DATA ROUTINE *****"
802 PRINT:PRINT:PRINT:PRINT:GOSUB2000
803 PRINTCHR$(147)
804 PRINTCHR$(147)"***** SAVE DATA CURVE *****"
808 PRINT
812 PRINTTAB(9)"1 - UPPER DET. RESP."
813 PRINTTAB(9)"2 - LOWER DET. RESP."
814 PRINTTAB(9)"3 - LIGHT PIPE RESP."
815 PRINTTAB(9)"4 - SYSTEM RESPONSE "
816 PRINTTAB(9)"5 - UPPER TRIM CURVE"
817 PRINTTAB(9)"6 - LOWER TRIM CURVE"
819 PRINT
824 PRINT:PRINTTAB(4)"9 - RETURN TO MAIN MENU"
826 PRINT
827 PRINT:PRINTTAB(4)"11 - RETURN TO DATA TABLE MENU"
828 PRINT:PRINTTAB(4)"12 - SAVE SYSTEM OUTPUT CURVES"
829 PRINT:PRINT
830 K=0:INPUT"SAVE CURVE NO. ";K
832 IFK=0THEN800
833 IFK>12THEN800
834 ONKGOTO836,836,836,836,836,836,900,800,100,1510,600,900
836 GOSUB260
837 PRINT:PRINT"CURRENT FILE WITH ABOVE NAME WILL BE ERASED FROM DISK"
842 PRINT:L$="":INPUT"MENU IF Y ";L$
843 IFL$="Y"THEN600
844 A$(K,1)=STR$(K):A$(K,3)="96"
845 OPEN15,8,15,"S:"+A$(K,2):INPUT#15,A$,B$,C$,D$:PRINTB$
846 CLOSE15
848 OPEN2,8,2,"0:"+A$(K,2)+",S,W"
850 FORI=1TO8
851 A$(K,I)="A"+A$(K,I):PRINT#2,A$(K,I)
852 NEXT
860 FORI=1TO96
862 PRINT#2,DT(K,I)
864 NEXT
866 PRINT#2,"END"
868 CLOSE2
870 GOTO100

```

```

900 PRINTCHR$(147)
904 PRINT:PRINT:PRINT:PRINT
906 PRINT"***** SAVE - SYSTEM OUT - CURVES *****"
908 PRINT:PRINT
910 PRINTTAB(4)"1 - ** SYSTEM OUTPUT **"
912 PRINTTAB(4)"3 - "
913 PRINTTAB(4)"4 - COMPONENT RESPONSE CURVES"
914 PRINTTAB(4)"7 - COMPOSIT RESP. - UPPER DET."
915 PRINTTAB(4)"8 - COMPOSIT RESP. - LOWER DET.":PRINT
916 PRINTTAB(4)"9 - MAIN MENU"
929 PRINT:PRINT
932 K=0:INPUT"COMMAND";K
933 IFK=0THEN900
934 IFK>10THEN900
935 GOSUB2000
936 ONKGO TO973,900,900,800,900,900,938,938,100,1520
938 PRINT"CURRENT FILE NAME IS: "A$(K,2)
939 GOSUB260
940 PRINT:PRINT"EXISTING CURVE OF THE SAME NAME WILL BE ERASED"
944 C$="":INPUT"MENU IF Y ";C$
945 IFC$="Y"THEN900
946 A$(K,1)=STR$(K):A$(K,3)="96"
947 OPEN15,8,15,"S:"+A$(K,2)
948 INPUT#15,A$,B$,C$:PRINT" B$:CLOSE15:L$="":INPUT"MENU IF Y";L$
949 IFL$="Y"THEN900
950 OPEN2,8,2,"0:"+A$(K,2)+",S,W"
954 FORI=1TO8
955 C$="A"+A$(K,I):PRINT#2,C$:PRINTC$
956 NEXT
960 FORI=1TO96
962 PRINT#2,DT(K,I):PRINTDT(K,I)
966 NEXT
970 PRINT#2,"END"
972 CLOSE2
973 GOTO900
974 GOSUB280
975 PRINT:PRINT"EXISTING CURVE OF THE SAME NAME WILL BE ERASED"
978 PRINT"FILE NAME NOW IS "B$(0,2)
980 C$="":INPUT"MENU IF Y ";C$
982 IFC$="Y"THEN900
983 B$(0,1)="0":B$(0,3)="64"
984 OPEN15,8,15,"S:"+B$(0,2)
985 INPUT#15,A$,B$,C$,D$:PRINTB$
986 CLOSE15
988 OPEN2,8,2,"0:"+B$(0,2)+",S,W"
990 FORI=1TO8
991 C$="A"+B$(0,I):PRINT#2,C$:PRINTC$
992 NEXT
993 FORI=1TO84
994 PRINT#2,CC(0,I):PRINTCC(0,I)
995 PRINT#2,CC(1,I):PRINTCC(1,I)
996 NEXT
997 PRINT#2,"END"
998 CLOSE2
999 GOTO100

```

```

1000 REM
1010 PRINTCHR$(147)
1012 PRINT"***** EDIT MENU *****"
1014 PRINT:PRINT:PRINT
1016 PRINT"1 - UPPER DET. RESP."
1017 PRINT"2 - LOWER DET. RESP."
1018 PRINT"3 - LIGHT PIPE"
1019 PRINT"4 - SYSTEM RESP."
1020 PRINT"5 - UPPER TRIM CURVE"
1021 PRINT"6 - LOWER TRIM CURVE"
1022 PRINT"7 - ** SYSTEM OUTPUT **"
1023 PRINT"8 - *** EXAMINE FILE ***"
1024 PRINT"9 - MAIN MENU":PRINT
1025 PRINT"10 - COMPOSIT RESP. * UPPER"
1028 PRINT"11 - COMPOSIT RESP. * LOWER":PRINT:PRINT
1029 K=0:INPUT"COMMAND";K

```

```

1030 IFK=8THEN3100
1032 IFK=0THEN1000
1033 IFK>11THEN1000
1034 IFK=9THEN100
1035 IFK<7THEND=96
1036 IFK=7THEND=84:GOTO1067
1037 IFK>9THENIFK<12THEND=96
1038 IFK=10THENK=7
1039 IFK=11THENK=8
1042 IFD=84THEN1067
1043 PRINTCHR$(147)
1044 PRINT
1045 PRINT"FILE: "A$(K,2)
1046 FORI=1TO8:PRINTI "A$(K,I):NEXT
1047 P=0:INPUT"CHANGE LINE NO. ";P
1048 PRINTA$(K,P)
1049 IFP=0THEN1052
1050 INPUT"CHANGE TO ";A$(K,P)
1051 GOTO1044
1052 E=0:INPUT"START AT ITEM ";E
1053 FORI=ETOE+10
1054 IFI>96THEN1060
1055 PRINTI "DT(K,I)
1058 NEXT
1060 H=0:INPUT"CHANGE LINE NO. ";H:IFH=0THEN1062
1061 INPUT"CHANGE TO ";DT(K,H)
1062 IFH<1THEN1064
1063 GOTO1053
1064 E=E+15
1065 IFI>96THEN1000
1066 GOTO1053

1067 PRINTCHR$(147)
1068 IFK=7THENK=0:PRINT"K="K
1069 FORI=1TO8:PRINTI "B$(0,I):NEXT
1071 C=0:INPUT"CHANGE LINE NO. ";C:IFC=0THEN1075
1072 PRINT B$(0,C)
1073 INPUT"ENTER CHANGE ";B$(0,C)
1074 GOTO1069
1075 C$="":INPUT"MENU IF Y ";C$:IFC$="Y"THEN1010
1076 PRINT:PRINT:E=1:INPUT"START AT ITEM NO. ";E
1078 PRINT
1079 PRINT"ITEM UPPER DET LOWER DET":PRINT" RATIO"
1080 FORI=ETOE+9
1082 IFI>84THEN1096
1084 PRINTI;
1085 PRINTTAB(4)CC(0,I);
1086 PRINTTAB(4)CC(1,I):IFCC(1,I)=0THENPRINTTAB(15)"*****":GOTO1088
1087 PRINT TAB(15)CC(K,I)/CC(K+1,I)
1088 IFI>83THEN1096
1089 NEXT
1096 D=0:INPUT"CHANGE LINE NO. ";D:IFD=0THEN1110
1097 INPUT"CHANGE UPPER VALUE TO ";CC(0,D)ADY.
1099 INPUT"CHANGE LOWER VALUE TO ";CC(1,D)
1105 PRINTCHR$(147):GOTO1079
1110 IFI>84THEN1000
1111 E=E+10
1112 C$="":INPUT"MENU IF Y ";C$
1113 IFC$="Y"THEN1000
1121 PRINTCHR$(147):PRINT:PRINT
1122 GOTO1078

1200 PRINTCHR$(147)"***** INPUT CURVE FROM DISK *****"
1203 PRINT:PRINT"TO EXAMINE DISK FILE GO TO EDIT FUNCTION OR * GOTO3100":PRINT
1204 PRINT:PRINT
1206 PRINT"DIRECTORY":PRINT
1208 GOSUB2000
1209 PRINT
1210 K$="":INPUT"ENTER FILE NAME ";K$
1220 E$="":INPUT"CORRECTION IF Y ";E$.
1221 IFE$="Y"THEN1224
1223 GOTO1230
1224 INPUT"ENTER CORRECTION ";K$
1230 E$="":INPUT"MENU IF Y ";E$
1231 IFE$="Y"THEN100

```

2-6

```

1232 OPEN15,8,15
1234 OPEN2,8,2,"0:"+K$,",S,R"
1235 FORI=1T08
1236 INPUT#2,C$(I):PRINTI"  "MID$(C$(I),2)
1237 NEXT
1238 D1=VAL(MID$(C$(1),2))
1239 D3=VAL(MID$(C$(3),2))
1240 GOTO1310
1250 OPEN2,8,2,"0:"+K$,",S,R"
1251 IFD1=0THEN1271
1254 IFD3=84THEN1271
1259 FORI=1T08:INPUT#2,C$:A$(D1,I)=MID$(C$,2):NEXT
1260 FORI=1T096
1262 INPUT#2,DT(D1,I)
1263 PRINTI"  "DT(D1,I)
1267 NEXT
1268 CLOSE2
1270 GOTO100
1271 FORI=1T08:INPUT#2,C$:B$(0,I)=MID$(C$,2):NEXT
1272 FORI=1T084
1274 INPUT#2,CC(0,I):INPUT#2,CC(1,I)
1279 NEXT
1281 CLOSE2
1284 GOTO100
1310 INPUT#15,A$,B$,C$,D$
1312 CLOSE2:CLOSE15
1314 IFA$="00"THEN1320
1316 PRINT:PRINTB$:FORI=1T02000:NEXT:GOTO1200
1320 REM
1321 E$="":INPUT"MENU IF Y ";E$:IFE$="Y"THENGOTO1200
1329 D1=VAL(MID$(C$(1),2))
1330 PRINT:PRINT"DESTINATION IS FILE NO, "D1
1332 PRINT:PRINT"FILES ARE AS FOLLOWS:"
1333 PRINTTAB(8)"0 - ** SYSTEM OUTPUT **"
1334 PRINTTAB(8)"1 - TOP DET RESP"
1335 PRINTTAB(8)"2 - BOT DET RESP"
1336 PRINTTAB(8)"3 - LIGHT PIPE RESP"
1337 PRINTTAB(8)"4 - SYSTEM RESPONSE"
1338 PRINT
1339 PRINTTAB(8)"7 - COMPOSIT RESPONSE - TOP"
1340 PRINTTAB(8)"8 - COMPOSIT RESPONSE - BOT"
1344 PRINT:PRINT"FILES GENERATED WITHIN THIS PROGRAM HAVE THE PROPER NUMBER."
1346 PRINT:INPUT"CHANGE DESTINATION TO ";D1
1348 L$="":INPUT"MENU IF Y ";L$:IFL$="Y"THEN1200
1350 GOTO1250

```

```

1400 PRINTCHR$(147)
1402 PRINT"***** PRINT DATA *****"
1404 PRINT:PRINT:PRINT
1406 PRINTTAB(6)"1 - UPPER DET. RESP."
1407 PRINTTAB(6)"2 - LOWER DET. RESP."
1408 PRINTTAB(6)"3 - LIGHT PIPE RESP."
1409 PRINTTAB(6)"4 - SYSTEM RESP."
1410 PRINTTAB(6)"5 - UPPER TRIM"
1411 PRINTTAB(6)"6 - LOWER TRIM"
1412 PRINTTAB(6)"7 - COMPOSIT RESP. - UPPER"
1413 PRINTTAB(6)"8 - COMPOSIT RESP. - LOWER"
1415 PRINTTAB(6)"9 - MENU"
1416 PRINT
1417 PRINTTAB(6)"10 - ** SYSTEM OUTPUT **"
1420 INPUT"COMMAND ";K
1422 IFK=0THEN1400
1424 IFK>10THEN1400
1426 IFK=9THEN100
1428 IFK<9THEN1434
1430 IFK=10THENK=0:GOTO1460
1434 OPEN4,4,0:CMD4
1436 PRINT"FILE: "A$(K,2):PRINT
1440 PRINT"COL "K":PRINT"  "A$(K,3)" DATA ITEMS"
1441 FORI=4T08:PRINTI"  "A$(K,I):NEXT
1442 GOTO1700
1443 PRINT:PRINT"WAVELENGTH  "AD$

```



```

1444 FORI=1T096
1446 Y=.3+(I+1)*.02
1448 PRINTYCHR$(16)CHR$(49)CHR$(53)DT(K,I)
1450 NEXT
1452 PRINT#4:CLOSE4
1456 GOTO1400
1460 OPEN4,4,0:CMD4:PRINT"SYSTEM OUTPUT CURVES":PRINT
1461 PRINT"      SOURCE CURVES="A$(7,2)" & "A$(8,2):PRINT
1462 FORI=1T08:PRINTI"  "B$(0,I):NEXT
1463 PRINT:TS=VAL(B$(0,4)):TD=VAL(B$(0,5)):TE=VAL(B$(0,6))
1464 PRINT"START AT "B$(K,4)", DELTA T "B$(K,5)", END AT "B$(K,6)
1465 PRINT
1466 PRINT"          UPPER DET.          LOWER DET. "
1468 PRINT"TEMP C.      CURREN          CURRENT          RATIO"
1470 PRINT
1472 FORI=1T084
1474 T=TS+(TD*(I-1))
1476 PRINTT;
1478 PRINTCHR$(16)CHR$(49)CHR$(49)CC(K,I);
1480 PRINTCHR$(16)CHR$(51)CHR$(49)CC(K+1,I);
1481 IFCC(1,I)=0THENCC(1,I)=1
1482 PRINTCHR$(16)CHR$(52)CHR$(45)CC(K,I)/CC(K+1,I)
1483 IFT=TETHEN1488
1484 IFT>TETHEN1488
1485 NEXT
1488 PRINT:PRINT
1490 PRINT#4:CLOSE4
1492 GOTO1400

```

```

1700 ONKGOTO171121,1712,1713,1715,1716,1717,1718,1719
1711 AD$="UPPER DET RESP.":RETURN
1712 AD$="LOWER DET RESP.":RETURN
1713 AD$="LIGHT PIPE TRANS":RETURN
1714 AD$="SYSTEM TRANS":RETURN
1715 AD$="UPPER TRIM TRANS":RETURN
1716 AD$="LOWER TRIM TRANS":RETURN
1718 AD$="COMP. RESP. UPPER":RETURN
1719 AD$="COMP. RESP. LOWER":RETURN
1730 RETURN

```

```

2000 H$="":INPUT"LIST DIRECTOPY IF Y ";H$
2002 IFH$="Y"THEN2006
2004 RETURN
2006 L$="":INPUT"IF PRINTOUT WANTED PRESS Y ";L$
2007 KK=1:REM PRINT COUNT
2008 OPEN1,8,0,"#0"
2009 IFL$="Y"THEN2015
2010 GOTO2020
2015 OPEN4,4,0
2020 GET#1,A$,B$
2030 GET#1,A$,B$
2040 GET#1,A$,B$
2050 C=0
2060 IFA$<>" "THENC=ASC(A$)
2070 IFB$<>" "THENC=C+ASC(B$)*256
2080 PRINTMID$(STR$(C),2);TAB(3);
2081 IFL$="Y"THENPRINT#4,MID$(STR$(C),2);
2090 GET#1,B$:IFST<>0THEN2200
2100 IFB$<>CHR$(34)THEN2090
2110 GET#1,B$:IFB$<>CHR$(34)THENPRINTB$;
2111 IFL$="Y"THEN2114
2112 IFB$<>CHR$(34)THEN2110
2113 GOTO2120
2114 IFB$<>CHR$(34)THENPRINT#4,CHR$(16)CHR$(000)CHR$(70)B$;GOTO2110
2120 GET#1,B$:IFB$=CHR$(32)THEN2120
2130 PRINTTAB(18);:C$=""
2140 C$=C$+B$:GET#1,B$:IFB$<>" "THEN2140
2150 PRINTLEFT$(C$,3):KK=KK+1
2151 IFL$="Y"THENPRINT#4,CHR$(16)CHR$(050)CHR$(000)LEFT$(C$,3)
2160 GETT$:IFT$<>" "THENGOSUB2300
2164 IFKK=20THENKK=1:GOTO2168
2166 GOTO2170
2168 INPUT"CONTINUE ON C.R. ";K
2170 IFST=0THEN2030

```

```

2200 PRINT" BLOCKS FREE"
2201 IFL$="Y"THENPRINT#4," BLOCKS FREE"
2205 CLOSE1
2206 IFL$="Y"THENPRINT#4:CLOSE4
2210 RETURN
2300 IFT$="Q"THENCLOSE1:GOTO2205
2310 GETT$:IFT$=""THEN2300
2320 RETURN

```

```

2400 PRINTCHR$(147)"***** SYOUT*CONSTANT *****"
2402 PRINT:PRINT
2404 PRINT"DEFAULT CONSTANT IS 1.0
2406 KT=1:KB=1
2408 INPUT"ENTER TOP CONST. ";KT
2410 INPUT"ENTER BOT CONST. ";KB
2412 A$(0,7)="KT="+STR$(KT)+"      KB="+STR$(KB)
2420 FORI=1TO84
2422 CC(0,I)=CC(0,I)*KT:CC(1,I)=CC(1,I)*KB
2423 PRINTCC(0,I)      "CC(1,I)
2424 NEXT
2425 PRINT"FINISHED"
2426 FORI=1TO800:NEXT
2460 GOTO100
3000 OPEN15,0,15
3010 INPUT#15,A$,B$,C$,D$
3020 CLOSE15
3030 PRINTA$,B$,C$,D$
3040 RETURN

```

```

3100 PRINTCHR$(147)"**** EXAMINE FILE *****":PRINT:PRINT
3110 INPUT"FILE NAME";F$
3120 INPUT"FILE TYPE";T$
3130 T$=LEFT$(T$,1)
3140 IFT$<"S"THENIFT$<"P"THENIFT$<"U"THEN3120
3145 OPEN15,0,15
3150 OPEN5,8,5,"0:"+F$+", "+T$+"R"
3160 GOSUB3200
3170 GET#5,A$
3180 IFST=0THEN3190
3185 IFST=64THENCLOSE5,15:GOTO3290
3187 PRINTST:GOTO3290
3190 PRINTA$;
3191 GOTO3170
3200 INPUT#15,A$,B$,C$,D$
3210 IFVAL(A$)>0THEN PRINTA$,B$,C$,D$
3220 RETURN
3290 INPUT"RETURN ON C.R.";X$
3291 GOTO1000

```

"WAT-CA96F"

200	370
CALCULATE COMPOSIT RESPONSE CURVES	

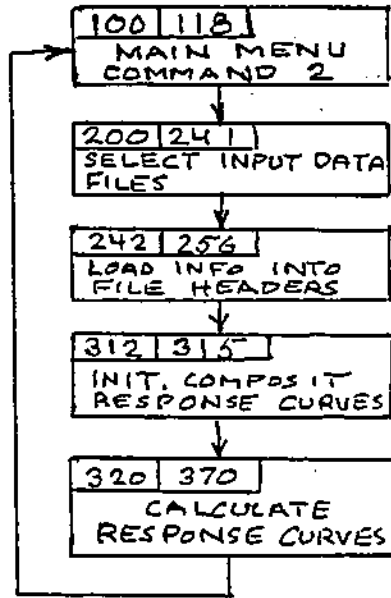

2B-2

"WAT-CA96F"

400 574  
CALCULATE SYSTEM  
OUTPUT CURVES

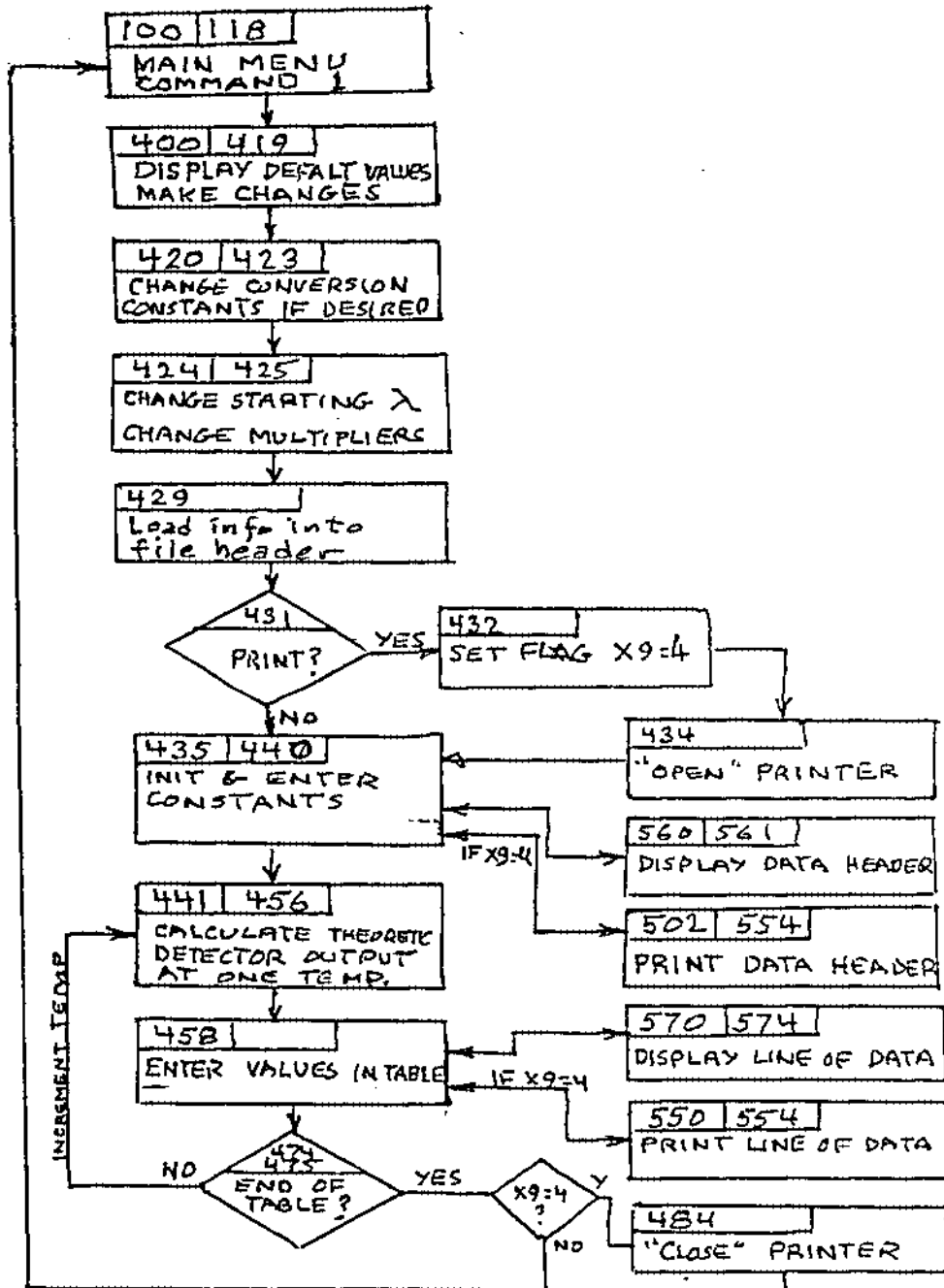

```

1 GOTO 8000 REM AUTO LIST INSTRUCTION
2 * WAT-CA96F-RD **
3 INITIALIZING DONE BY RUN COMMAND.
5 DIM STATEMENTS:
6 . DT * 8 MAIN DATA TABLES.
7 . A$ * HEADER LINES FOR ABOVE DATA TABLES.
10 . CC * SYSTEM OUTPUT CURVES.
12 . B$ * HEADER LINES FOR OUTPUT CURVES.
50 . ZZ IS A FLAG * SEE LINES 102 AND 201.
100 CHR$(147) IS CLEAR SCREEN CMD.
101 *IMPORTANT!* RESTART AT MENU TO PRESERVE DATA.
102 PRINTS * COMPOSIT CURVE COMPLETE * IF TRUE.

104 .
105 .
106 .
107 .
108 .
109 .
110 .
113 .
114 POSITION COMMAND REQUEST.
115 .
118 ADDRESSES OF MENU SELECTIONS.
130 LINE 2006 IS DIRECTORY PRINTOUT SUBROUTINE.
131 END OF DIRECTORY LISTING RETAINS SCREEN DATA.
132 .
200 .

201 .
202 .
204 .
209 INITIALIZE CURVE SELECTION FLAGS.
210 ZERO IS "DONT USE" ONE IS "USE".
211 .
212 .
214 .
215 .
218 .
219 .
222 .
223 .
226 .
227 .
228 VERIFICATION OF SELECTIONS.
240 PERMITS START OVER IN CASE OF ERROR.
241 .
242 .
252 .
255 LOADS ITEMS 7 & 8 OF HEADER WITH LIST OF CURVES USED.
256 .
257 LINE 312 IS START OF CALCULATIONS.
260 START OF A HEADER EDIT SUBROUTINE.
264 EDITS DATA FILE HEADER.
266 .
268 A$(A,B) EDIT
269 . *****
270 . * THIS SUBROUTINE CALLED *
271 . * AT LINE 836 IN - SAVE *
272 . * DATA ROUTINE : ALSO *
273 . * CALLED AT LINE 939 *
274 . *****
280 START OF HEADER EDIT SUBROUTINE
284 EDITS SYSTEM OUTPUT CURVE HEADER.
286 B$(A,B) EDIT
288 . *****
289 . * LINE 280 CALLED FROM *
290 . * LINE 973 *
291 . *****
292 .
294 .

```

```

312 INITIALIZE CURVE #7 TO 1.0
313 INITIALIZE CURVE #8 TO 1.0
314 .
315 .
320 CALCULATE VALUES FOR CURVE #7
323 UPPER DETECTOR.
325 .
327 .
329 .
330 .   DISPLAY DATA AS CALCULATED.
331 TIME DELAY FOR READABILITY.
332 .
333 .
340 CALCULATE VALUES FOR CURVE #8
343 LOWER DETECTOR.
345 .
347 .
349 .
350 DISPLAY DATA
351 TIME DELAY
352 .
353 .
355 TIME DELAY FOR VIEWING SCREEN.
360 PUT MESSAGE ON LINE 102 OF MAIN MENU.
370 .

400 .
401 .
402 .
403 .
410 DEFAULT VALUE.
411 DEFAULT VALUE.
412 DEFAULT VALUE.
413 .
416 CHANGE VALUE IF DESIRED.
417 CHANGE VALUE IF DESIRED.
418 REJECTS INPUT OF LESS THAN 20.
419 CHANGE VALUE.
420 OUTPUT CONSTANT * TOP DETECTOR * AMPS OUT PER WATT IN.
421 CHANGE IF DESIRED.
422 OUTPUT CONSTANT * BOT DETECTOR * AMPS OUT PER WATT IN.
423 CHANGE IF DESIRED.
424 W9 IS STARTING WAVELENGTH OF TABLE.
425 K9 ALTERS CURVES OF BOTH DETECTORS BY SAME MULTIPLIER.
428 .
429 PUT INFO IN HEADER LINES 3, 4, 5, & 6.
430 .
431 ENTER Y FOR HARD COPY.
432 SET HARD COPY FLAG.
434 TURN ON PRINTER * USE PRINT#4 COMMAND TO PRINT DATA.
435 .
436 C1 FOR EQUATION LINE 450.
437 C2 FOR EQUATION LINE 450.
438 DISPLAY PART OF DISPLAY HEADER.
439 ROUTINE TO PRINT HEADER INFO ON HARD COPY.
440 T = STARTING TEMPERATURE.
441 K = STARTING TEMP. IN DEG. K .
442 .
443 .
444 .
445 WT = TOP DET ACCUMULATOR * WU = BOT DET ACCUMULATOR.
446 .
447 .
448 CALCULATE DET. OUTPUTS FOR EACH TEMPERATURE.
449 CALC WAVELENGTH = Y.
450 PLANKS LAW CALC FOR BLACK BODY OUTPUT.
452 MULT BY REL RESP. AND BY RESP AT PEAK.
453 MULT BY REL RESP. AND BY RESP AT PEAK.
454 ADD TO SUBTOT.
455 ADD TO SUBTOT.
456 .

```

458 ENTER TABLE VALUE \* OUTPUT CURRENT OF TOP DET.  
460 ENTER TABLE VALUE \* OUTPUT CURRENT OF BOT DET.  
467 HARD COPY PRINTOUT.  
468 DISPLAY DATA.  
474 CHECK FOR END OF TABLE.  
475 CHECK FOR END OF TABLE.  
478 INCREMENT TEMPERATURE.  
479 INCREMENT TABLE LINE POINTER.  
480 CALCULATE NEXT VALUE IN TABLE.  
482 CHANGE DISPLAY MESSAGE FOR LINE 102.  
484 TURN PRINTER OFF IF IN USE.  
485 RETURN TO MAIN MENU WHEN READY.  
490 REM ????  
492 REM ????  
494 .

500 .  
502 START OF SUBROUTINE FOR HARD COPY OF SYS. OUTPUT CURVES.  
504 .  
506 .  
507 CHANCE TO CORRECT ERROR.  
508 .  
509 .  
510 .  
511 .  
512 .  
513 .  
514 .  
515 .  
516 .  
517 .  
518 .  
519 .  
520 . PRINTER TAB COMMANDS \* SEE BOOK.  
522 . ASSUMES USE OF COMMODORE 801 PRINTER.  
523 .  
524 .  
525 .  
526 .  
527 .  
528 END OF HEADER SUBROUTINE.  
530 .  
531 .  
532 .  
533 .  
534 END OF DATA PRINT SUBROUTINE.  
560 DISPLAY HEADER.  
561 .  
562 .  
564 .  
570 DISPLAY DATA.  
572 .  
574 .

600 CLEAR SCREEN.  
602 \*\*\*\*\* DATA TABLE MENU \*\*\*\*\*  
604 .  
606 INPUT DATA ROUTINE @ LINE 700 VIA LINE 651.  
607 INPUT DATA ROUTINE @ LINE 700 VIA LINE 653.  
608 INPUT DATA ROUTINE @ LINE 700 VIA LINE 655.  
609 INPUT DATA ROUTINE @ LINE 700 VIA LINE 657.  
610 INPUT DATA ROUTINE @ LINE 700 VIA LINE 659.  
611 INPUT DATA ROUTINE @ LINE 700 VIA LINE 661.  
612 INPUT FROM DISK @ LINE 1200  
613 TO EDIT MENU @ LINE 1000.  
615 .  
616 ↑↑↑↑↑↑↑↑ END OF MENU ↑↑↑↑↑↑↑↑↑↑↑↑  
624 .  
626 .  
628 .  
630 MAKE MENU SELECTION.

```

631 .
632 .
633 .
634 MENU SELECTION ADDRESSES.
651 ASSIGN HEADER TITLE.
652 ASSIGN FILE NUMBER.
653 ASSIGN HEADER TITLE.
654 ASSIGN FILE NUMBER.
655 ASSIGN HEADER TITLE.
656 ASSIGN FILE NUMBER.
657 ASSIGN HEADER TITLE.
658 ASSIGN FILE NUMBER.
659 ASSIGN HEADER TITLE.
660 ASSIGN FILE NUMBER.
661 ASSIGN HEADER TITLE.
662 ASSIGN FILE NUMBER.
700 ----- START DATA ENTRY ROUTINE -----
710 INIT ITEM SUBSCRIPT NUMBER.
712 INPUT VALUE.
714 KEEPS OLD VALUE IF NO ENTRY MADE.
716 ESCAPE OR MAKE CORRECTION
718 .
720 INCREMENT SUBSCRIPT.
721 TO MAIN MENU IF TABLE COMPLETE.
722 TO - ENTER NEXT LINE.
790 INPUT LINE TO BE CORRECTED.
791 IF NO ENTRY ABOVE - GOTO MENU.
792 RESET SUBSCRIPT NUMBER.
794 TO - ENTER NEXT LINE.
798 NOT NEEDED.

800 .
801 .
802 SUBROUTINE AT LINE 2000 PERMITS LISTING.
803 OR PRINTING OF THE DISK DIRECTORY.
804 *** SAVE DATA SET MENU *****
808 .
812 .
813 .
814 .
815 .
816 .
817 .
819 .
824 .
825 .
826 .
827 .
828 .
829 ↑↑↑↑↑↑↑↑ END OF MENU ↑↑↑↑↑↑↑↑
830 INPUT NUMBER OF CURVE TO BE SAVED.
832 ASK FOR COMMAND IF PREVIOUS INPUT
833 WAS OUT OF LIMITS.
834 COMMAND ADDRESSES.
836 SUBROUTINE AT 260 PERMITS CHANGE OF FILE NAME.
837 .
842 EXIT TO DATA TABLE MENU IF DESIRED.
843 .
844 ENTER VALUES IN HEADER STRINGS 1 AND 3.
845 SCRATCH FILE FROM DISK AND CHECK RESULT.
846 CLOSE COMMAND CHANNEL.
848 SET UP TO SAVE FILE.
850 SAVE FILE HEADER.
851 .
852 .
860 SAVE 96 ITEM DATA FILE.
862 .
864 .
866 END OF FILE MARKER.
868 CLOSE CHANNEL 2.
870 .

```



```

900 .
904 .
906 ***** MENU ** SAVE SYS OUT CURVES *****
908 .
910 .
912 .
914 .
915 .
916 .
929 ↑↑↑↑↑↑↑↑ END OF MENU ↑↑↑↑↑↑↑↑↑↑
932 .
933 PROTECTS AGAINST OUT OF LIMIT COMMAND.
934 .
935 CALLS DIRECTORY LIST SUBROUTINE.
936 COMMAND ADDRESSES.
938 .
939 CALLS NAME CHANGE SUBROUTINE.
940 .
944 RETURN TO ABOVE MENU OPTION.
945 .
946 PUT VALUES IN HEADER LINES 1 AND 3.
947 SCRATCH DISK FILE.
948 VERIFY AND CLOSE COMMAND CHANNEL.
949 .
950 OPEN FILE #2 TO SAVE FILE.
954 SAVE HEADER.
955 INSERT EXTRA CHARACTER IN LINE TO.
956 AVOID NULL STRING.
960 SAVE 96 ITEM DATA SET.
962 .
966 .
970 END OF FILE MARKER.
972 CLOSE FILE - RETURN TO MENU.
973 CALL HEADER EDIT ROUTINE.
974 .
975 .
978 .
980 ESCAPE TO MENU.
982 CONDITIONAL RETURN TO MENU
983 ENTER HEADER INFORMATION
984 SCRATCH EXISTING FILE
985 READ DISK DRIVE STATUS
986 CLOSE COMMAND CHAN.
988 OPEN FILE TO WRITE
990 WRITE HEADER TO DISK
991 .
992 .
993 WRITE DATA TO DISK
994 .
995 .
996 .
997 END OF RECORD MARKER
998 CLOSE FILE
999 .

```

```

1000 .
1010 .
1012 ***** EDIT MENU *****
1014 .
1016 . *****
1017 . * LIST OF ALL OF THE DATA *
1018 . * USED IN THIS PROGRAM. *
1019 . *****
1020 .
1021 .
1022 .
1023 EXAMINE FILE READS FILE FROM DISK AND
1024 DISPLAYS IT. IT IS NOT PUT INTO MEMORY.
1025 .
1028 ↑↑↑↑↑↑↑↑ END OF MENU ↑↑↑↑↑↑↑↑
1029 SELECT CURVE TO BE EDITED.

```

```

1030 .
1032 .
1033 .
1034 .
1035 . : SUBSCRIPT D IS NUMBER .
1036 . : OF DATA ITEMS IN FILE. .
1037 . : D IS USED TO SET LOOP .
1038 . : D IS USED TO SET LOOP .
1039 . : LENGTH .
1042 .
1043 .
1044 .
1045 LINE 2 OF FILE HEADER.
1046 DISPLAY FILE HEADER.
1047 .
1048 .
1049 .
1050 .
1051 .
1052 INPUT SYBSCRIPT FOR DATA LIST.
1053 DISPLAY 10 DATA ITEMS STARTING AT ABOVE SUBSCRIPT.
1054 CHECK FOR END OF LIST.
1055 .
1058 .
1060 IF NO ENTRY, DISPLAY NEXT 10 ITEMS .
1061 .
1062 .
1063 CHANGE HAS BEEN MADE - REDISPLAY ITEMS.
1064 .
1065 IF AT END OF TABLE, RETURN TO EDIT MENU.
1066 .

```

```

1067 .
1068 CHANGE COMMAND NUMBER TO FILE ID NUMBER.
1069 EDIT SYSTEM OUTPUT CURVES
1071 .
1072 .
1073 .
1074 .
1075 .
1076 .
1078 .
1079 .
1080 .
1082 .
1084 .
1085 .
1086 .
1087 .
1088 .
1089 .
1096 .
1097 .
1099 .
1105 .
1110 .
1111 .
1112 .
1113 .
1121 .
1122 ↑↑↑↑ END OF EDIT ROUTINES ↑↑↑↑

```

```

1200 ***** INPUT CURVE FROM DISK *****
1203 .
1204 .
1206 .
1208 SUBROUTINE AT 2000 LISTS DISK DIRECTORY.
1209 .
1210 .
1220 .
1221 .
1223 .
1224 .
1230 ESCAPE TO MAIN MENU IF DESIRED.
1231 .

```

1232 OPEN COMMAND CHANNEL SO THAT ERRORS CAN BE READ.  
1234 OPEN FILE FOR READ.  
1235 READ HEADER.  
1236 DISPLAY HEADER AS READ.  
1237 .  
1238 SET D1 EQUAL TO FILE NUMBER.  
1239 SET D3 EQUAL TO NUMBER OF DATA ITEMS.  
1240 SUBROUTINE AT 1310 CHECKS FOR DISK ERROR & CLOSES FILES.  
1250 OPEN FILE FOR READ.  
1251 SSELECT CORRECT READ ROUTINE.  
1254 SSELECT CORRECT READ ROUTINE.  
1258 READ HEADER.  
1260 READ DATA.  
1262 .  
1263 DISPLAY DATA AS READ.  
1267 .  
1268 .  
1270 GOTO MAIN MENU  
1271 READ HEADER.  
1272 READ DATA.  
1274 .  
1279 .  
1281 .  
1284 GOTO MAIN MENU.  
1310 SUBROUTINE - READ DISK STATUS.  
1312 CLOSE CHANNELS.  
1314 IF FILE EXISTS, CONTINUE.  
1316 IF ERROR, PRINT TYPE OF ERROR AND START OVER.  
1320 .  
1321 ESCAPE IF DESIRED.  
1329 SET D1 EQUAL TO FILE NUMBER.  
1330 VERIFY D1  
1332 .  
1333 .  
1334 . . . . . LIST OF FILES BY NUMBERS .  
1335 . . . . . AND FUNCTION. .  
1336 . . . . .  
1337 .  
1338 .  
1339 .  
1340 . ↑↑↑↑↑ END OF LIST ↑↑↑↑↑  
1344 .  
1346 .  
1348 .  
1350 INITIATE INPUT OF FILE FROM DISK.

1400 .  
1402 \*\*\*\*\* PRINT DATA MENU \*\*\*\*\*  
1404 .  
1406 .  
1407 .  
1408 .  
1409 .  
1410 .  
1411 .  
1412 .  
1413 .  
1415 .  
1416 .  
1417 ↑↑↑↑↑↑↑↑ END OF MENU ↑↑↑↑↑↑↑↑  
1420 SELECT FILE TO BE PRINTED.  
1422 CHECK FOR OUT OF RANGE.  
1424 CHECK FOR OUT OF RANGE.  
1426 .  
1428 GOTO PRINT ROUTINE FOR ALL FILES EXCEPT SYS. OUT.  
1430 GOTO PRINT ROUTINE FOR SYSTEM OUTPUT ONLY.  
1434 ENABLE PRINTER.  
1436 PRINT FILE NAME.  
1440 PRINT INFO.  
1441 PRINT FIRST 4 HEADER LINES.  
1442 SUBROUTINE AT 1700 SELECTS TITLE.  
1443 START DATA PRINTOUT.

1444 .  
1446 CALCULATE WAVELENGTH FOR DATA ENTRY.  
1448 TAB AND PRINT.  
1450 .  
1452 DISENABLE PRINTER  
1456 RETURN TO PRINT DATA MENU.  
1460 ENABLE PRINTER.  
1461 .  
1462 .  
1463 SET TEMPERATURE DATA FROM FILE HEADER.  
1464 VERIFY LIMITS AND INCREMENT OF TEMPERATURE.  
1465 .  
1466 .  
1468 .  
1470 .  
1472 START LOOP TO PRINT DATA TABLE.  
1474 CALC. TEMPERATURE.  
1476 .  
1478 TAB AND PRINT  
1480 TAB AND PRINT  
1481 CHANGE 0 TO 1 --- PREVENT DIVISION BY ZERO ERROR.  
1482 TAB AND PRINT  
1483 CHECK FOR END OF PRINTOUT.  
1484 SECOND CHECK FOR END OF PRINTOUT.  
1485 .  
1488 .  
1490 DISENABLE PRINTER.  
1492 RETURN TO PRINT DATA MENU

1700 SUBROUTINE SELECTS PROPER FILE NAME1669  
1711 FOR STRING VARIABLE.  
1712 .  
1713 .  
1714 .  
1715 .  
1716 .  
1718 .  
1719 .  
1730 ↑↑↑ END OF SUBROUTINE ↑↑↑

2000 SUBROUTINE READS DISK DIRECTORY \*\*  
2002 .  
2004 .  
2006 THIS ROUTINE WAS FOUND IN A BOOK.  
2007 NO EXPLANATIONS WERE GIVEN.  
2008 .  
2009 .  
2010 .  
2015 .  
2020 .  
2030 .  
2040 .  
2050 .  
2060 .  
2070 .  
2080 .  
2081 .  
2090 .  
2100 .  
2110 .  
2111 .  
2112 .  
2113 .  
2114 .  
2120 .  
2130 .  
2140 .  
2150 .  
2151 .  
2160 .  
2164 .  
2166 .  
2168 .  
2170 .



APPENDIX D3

COMPUTER PROGRAM A/D READ-M10

```

1 REM PROGRAM A/D READ-M10
2 REM DATE 5/17/85
3 POKE55,00:POKE56,145:REM LOWER TOP OF BASIC TO PROTECT MACODE
4 REM CHANGED ROUND OFF - AVOID STORAGE IN FLOAT PT OF FINAL ANSWER
5 REM LINES1700-1740 ARE OK NOW
7 REM ALT ROUND OFF - LINES 2000-2018
8 REM USING LINES 1700-1740 FOR ROUND OFF
9 DIM CF(20),GF(20),DD(20),B$(20),E$(12),N$(12)
10 DIM A4(255)
11 POKE57343,2
12 DIM MA(256)
14 DIM CC(3,90)
15 DIM D(18),G(18),Q$(18)
16 SK=1
17 G(0)=1
18 G(1)=1
20 G(2)=1.9531E-6
21 G(3)=1.0255E-7
22 G(4)=3.1091E-9
24 G(5)=9.3614E-2
25 G(6)=4.8603E-7
26 G(7)=2.1028E-8
27 G(8)=9.821E-10
28 G(9)=9.2525E-2
29 REM ENTRY DATE 3-12-85
30 G(12)=G(2)*G(5)
31 G(13)=G(3)*G(5)
32 G(14)=G(4)*G(5)
33 G(16)=G(6)*G(9)
34 G(17)=G(7)*G(9)
35 G(18)=G(8)*G(9)
64 B$(0)="CHAN ZERO":CF(0)=0:GF(0)=0:DD(0)=0
65 B$(1)="TOP LO*10X ":CF(1)=3:GF(1)=0:DD(1)=14
66 B$(2)="TOP LO ":CF(2)=1:GF(2)=0:DD(2)= 4
67 B$(3)="TOP MID*10X":CF(3)=3:GF(3)=1:DD(3)=13
68 B$(4)="TOP MID ":CF(4)=1:GF(4)=1:DD(4)= 3
69 B$(5)="TOP HI*10X ":CF(5)=3:GF(5)=2:DD(5)=12
70 B$(6)="TOP HI ":CF(6)=1:GF(6)=2:DD(6)= 2
71 B$(7)="BOT LO*10X ":CF(7)=4:GF(7)=0:DD(7)=18
72 B$(8)="BOT LO ":CF(8)=2:GF(8)=0:DD(8)= 8
73 B$(9)="BOT MID*10X":CF(9)=4:GF(9)=1:DD(9)=17
74 B$(10)="BOT MID ":CF(10)=2:GF(10)=1:DD(10)= 7
75 B$(11)="BOT HI*10X ":CF(11)=4:GF(11)=2:DD(11)=16
76 B$(12)="BOT HI ":CF(12)=2:GF(12)=2:DD(12)= 6
80 IF(PEEK(38143))<>7THENUU$="LD":GOTO350
81 POKE38142,1
86 GOTO200

```

```

100 PRINTCHR$(147):PRINT:PRINT:PRINT"*****";
101 PRINT" MAIN MENU *****"
102 PRINT:PRINT:PRINT
104 PRINTTAB(3)"1 - READ PROBE OUTPUT "
106 PRINTTAB(3)"2 - LOAD TEMPERATURE RATIO CURVE"
108 PRINTTAB(3)"3 - LOAD MACH. PROGRAM"
110 PRINTTAB(3)"4 - TRANSFER SEQ FILE TO ANOTHER"
111 PRINTTAB(10)"DISK":PRINT
112 PRINTTAB(3)"5 - GET ZERO READINGS "
114 PRINTTAB(3)"6 - READ A/D - ANY SINGLE CHANNEL"
116 PRINTTAB(3)"7 - PRINT ZERO READINGS"
118 PRINTTAB(3)"8 - INIT ZERO RDG. TABLE"
119 PRINTTAB(3)"9 - CONTINUOUS READ - NO HEADER"
120 PRINT:PRINT:PRINTTAB(12);:U=0:INPUT"COMMAND";U
122 IFU=0THEN100
124 IFU>9THEN100
126 ON U GOTO 180,200,300,2400,500,600,160,800,170
160 GOSUB1800
162 GOTO100
170 WW=88:FL=1
171 GOTO709
180 WW=0:FL=0
181 GOTO700

```

```

200 PRINTCHR$(147):PRINT
201 PRINT"***** LOAD TEMPERATURE RATIO CURVE *****"
202 K$="SYSOUT-02"
203 PRINTTAB(5)"FILE TO BE LOADED IS "K$
204 PRINT:PRINTTAB(5)"***** MENU *****":PRINT
205 PRINTTAB(5)" 9 - MAIN MENU"
206 PRINTTAB(5)" RETURN - CONTINUE "
207 PRINTTAB(5)" C - CHANGE FILE NAME"
208 PRINT:L$=""
209 PRINTTAB(5);:INPUT" COMMAND";L$
210 IFL$="9"THEN100
211 IFL$="C"THEN213
212 GOTO220
213 PRINT:INPUT"CHANGE NAME TO ";K$
220 INPUT"PRESS RETURN WHEN READY";R$
222 PRINT:PRINT"LOADING FILE "K$ " - PLEASE WAIT"
226 OPEN2,8,2,"0:"+K$+",S,R"
228 FORI=1TO8
230 INPUT#2,CA$
232 AW$(I)=MID$(CA$,2)
234 NEXT
235 CLOSE2
236 PRINT:IFAW$(2)<>K$THENCLOSE2:PRINT"FILE "K$" NOT FOUND":GOTO204
238 PRINT:PRINT"***** FILE HEADER *****"
239 PRINT
240 FORU=1TO8
241 PRINT"AW$(U)="AW$(U)
242 NEXT
245 OPEN2,8,2,"0:"+K$+",S,R"
246 FORI=1TO8
247 INPUT#2,CA$
249 NEXT
251 PRINT"LOADING DATA"
252 FORI=1TO84
254 INPUT#2,CC(0,I)
256 INPUT#2,CC(1,I)
258 NEXT
260 CLOSE2:PRINT"CALCULATING TABLE"
261 TS=VAL(AW$(4)):REM LO TEMP
262 TD=VAL(AW$(5)):REM TEMP INCREMENT
263 TE=VAL(AW$(6)):REM HIGH TEMP
264 FORI=1TO84
265 IFCC(1,I)=0THENCC(1,I)=1
266 CC(2,I)=TS+((I-1)*TD)
268 CC(3,I)=CC(0,I)/CC(1,I)
269 GOTO272
270 PRINTCC(2,I)" "CC(3,I)
272 IFCC(2,I)=>TETHEN275
274 NEXT
275 PRINT:PRINT
276 PRINT"RATIO AT "CC(2,1)" DEG.= "CC(3,1)
278 PRINT"RATIO AT "CC(2,I)" DEG.= "CC(3,I)
280 FORI=1TO2500:NEXT
299 GOTO100

300 PRINTCHR$(147):PRINT:PRINT:PRINT
302 PRINTTAB(3)"***** LOAD MACODE *****"
303 PRINT:PRINT:PRINT
308 PRINTTAB(5)"PRESS RETURN TO LOAD MACODE"
330 PRINTTAB(5);:K$="":INPUT"PRESS Y TO ESCAPE TO MENU";K$
332 IFK$="Y"THEN100
333 PRINT:PRINT
350 PRINT"CHECKING FOR PRESENCE OF MACODE"
351 POKE38143,7
352 OPEN2,8,2,"0:MACODE,S,R"
353 FORI=1TO8
354 INPUT#2,D$
355 A$(I)=MID$(D$,2)
356 PRINTA$(I)
357 NEXT
358 IFA$(2)<>"MACODE"THENCLOSE2:PRINT"FILE NOT FOUND":POKE38143,0:GOTO390
359 PRINT"READING DISK AND LOADING MEMORY"
360 J=37888

```



```

362 FORI=1TO255
364 INPUT#2,A4
365 POKEJ,A4:J=J+1:PRINTJ" "A4
366 NEXT
368 CLOSE2
386 IFUU$="LD"THENUU$="":GOTO81
387 GOTO100
390 PRINT:L$="":INPUT"RETRY IF Y ";L$
392 IFL$="Y"THEN350
394 GOTO100

```

```

500 PRINTCHR$(147):PRINT:PRINT
502 PRINT"***** ZERO READINGS ON ALL RANGES *****"
504 PRINT:PRINT"PLEASE WAIT"
508 FORI=1TO12
530 POKE57343,GF(I)
532 FORU=1TO450:NEXT
533 VB=0
534 FORT=1TO12
535 CH=CF(I)
536 GOSUB1145
537 IFT<3THENR4=0:GOTO542
538 VB=VB+R4
540 PRINT"R4= "R4" VOLTS"
542 NEXT
546 D(DD(I))=(VB/10)
547 PRINT"D("DD(I)")= "D(DD(I))" "B$
550 NEXT
551 FORU=1TO700:NEXT:PRINTCHR$(147):PRINT:PRINT:PRINT
552 FORI=1TO12STEP2
554 PRINTB$(I)"= "D(DD(I))" VOLTS
555 PRINTB$(I+1)"= "D(DD(I+1))" VOLTS
556 PRINT
558 NEXT
567 PRINT
569 PRINT"READING TIME":GOSUB1400
570 POKE38142,9:REM ZERO RDG. FLAG
571 ND$=YD$:NS$=HS$
572 K$="":INPUT"DO OVER IF Y ";K$
574 IFK$="Y"THENPOKE38142,0:GOTO500
576 A$="":INPUT"PRINT LIST IF Y ";A$
578 IF A$="Y"THENGOSUB1800
580 GOTO100

```

```

600 PRINTCHR$(147):PRINT
602 PRINT"***** READ A/D * INDIVIDUAL RANGES *****"
604 PRINT"***** MENU *****"
606 PRINT
610 PRINT" 0 - CHANNEL ZERO"
612 FORI=1TO12STEP2
614 PRINTI" - "B$(I)" : "I+1" - "B$(I+1)
616 NEXT
618 PRINT
620 PRINT" 90 - MAIN MENU "
621 PRINT
622 K=0:PRINTTAB(12);INPUT"COMMAND";K
624 IFK=90THEN100
625 IFK>12THEN600
641 IFK>12THEN100
642 GT=GF(K):CH=CF(K)
660 PRINT
662 GOSUB1120
666 PRINT"***** "B$(K)" RANGE *****"
668 XA=R4
669 VA=R4*G(DD(K)):VA$=STR$(VA):VB$="AMP"
670 IFK=0THENVA$="":VB$=""
671 PRINT"OUTPUT IS "XA" VOLTS":PRINT" = "VA$ "VB$
672 PRINT
680 K$="":INPUT"MAIN MENU IF Y";K$
682 IFK$="Y"THEN100
688 GOTO600

```

```

700 REM
701 PRINTCHR$(147):PRINT:PRINT:PRINT"***** READ PROBE OUTPUT *****"
702 PRINT:IFPEEK(38142)=1THENPRINT"ZERO READINGS HAVE NOT BEEN TAKEN":GOTO790
703 K$="":INPUT"PRINTOUT WANTED IF Y ";K$:PRINT
704 FL=0:IFK$="Y"THENFL=1
705 IFFL=0THEN707
706 GOSUB1565
707 PRINTTAB(3)"PRESS RETURN TO ";
708 INPUT"START READING";K$
709 PRINT:PRINT"READING - PLEASE WAIT"
710 GOSUB902
712 PRINT"TOP DET OUTPUT = "XT" AMPS"
722 PRINT"BOT DET OUTPUT = "XB" AMPS"
724 IFXB=0THENXB=1:GOTO728
726 GOTO730
728 PRINT:PRINT"DATA IN ERROR"
730 RT=XT/XB
732 BT=(INT((XT/XB)*10000))/10000
744 PRINT:PRINT"RATIO OF OUTPUTS IS "BT
745 GOSUB1200
747 GOSUB1240
748 W1$=STR$(TT):IFTT$="<"THENW1$=MID$(AW$(5),2)
749 IFTT$=">"THENW1$=MID$(AW$(6),2)
754 W2$=STR$(BB):IFBB$="<"THENW2$=MID$(AW$(5),2)
755 IFBB$=">"THENW2$=MID$(AW$(6),2)
762 IFVAL(AW$(3))<1THENW1$="NO TABL":W2$="NO TABL":TT$="":BB$=""
764 W6$=STR$(TM)
766 IFVAL(AW$(3))<1THENTM$="":W6$="NO TABL":TM$=""
767 IFTM$="<"THENW6$=MID$(AW$(4),2)
768 IFTM$=">"THENW6$=MID$(AW$(6),2)
780 PRINT"T-TOP= "TT$+W1$" T-BOT= "BB$+W2$
781 PRINT"INDICATED TEMP= "TM$+W6$
783 IFFL=0THEN786
784 GOSUB1500
785 IFWW=88THENGOTO788
786 PRINT:K$="":INPUT"MENU IF Y * OTHERWISE RESET";K$
787 IFK$="Y"THEN100
788 GOTO709
790 PRINT:PRINTTAB(10);
794 K$="":INPUT"MENU IF Y ";K$
795 IFK$="Y"THEN100
796 PRINT
797 GOTO703

```

```

800 PRINTCHR$(147)"***** INIT ZERO RDG. TABLE *****"
810 FORI=2TO4
812 D(I)=0
814 D(I+10)=0
816 NEXT
820 FORI=6TO8
822 D(I)=0
824 D(I+10)=0
826 NEXT
829 POKE38142,1
830 GOTO100

```

```

900 REM FIND BEST RANGE FOR TOP DET.
902 T=0:TH=3
904 GOSUB1100
906 IFR4>9THEN910
908 GOTO950
910 TH=1
912 GOSUB1100
914 IFR4>9THEN910
916 GOTO950
918 OT=1:TH=3
920 GOSUB1100
922 IFR4>9THEN926
924 GOTO950
926 TH=1
928 GOSUB1100
930 IFR4>9THEN934
932 GOTO950

```

```

934 GT=2:TH=3
936 GOSUB1100
938 IFR4>9THEN942
940 GOTO950
942 TH=1
944 GOSUB1100
946 IF(R2+R3)>3638THENPRINT"PUT OF RANGE"
947 GOTO950
948 FORY=1TO1000:NEXT:GOTO700
950 BH=4
951 GOSUB1110
952 GOSUB1400
954 IFR4>9THEN958
956 GOTO970
958 BH=2
970 VT=0:VB=0
971 REM READ 10 ALTERNATE READINGS OF EACH DET.
972 FORL=1TO10
973 CH=BH
974 GOSUB1145
975 IFR4>9.98THENPRINT"BOTTOM OUT OF RANGE":FORM=1TO1000:NEXT:GOTO700
977 VB=VB+R4
979 CH=TH
980 GOSUB1145
982 IFR4>9.98THENPRINT"TOP OUT OF RANGE":FORM=1TO1000:NEXT:GOTO700
984 VT=VT+R4
990 NEXT
991 REM NEXT SELECT GAIN SUBSCRIPTS
993 PRINT
994 IFTH=3THENQR=(4-GT)+10
995 IFTH=1THENQR=(4-GT)
996 IFBH=4THENLV=(8-GT)+10
997 IFBH=2THENLV=(8-GT)
1002 PRINT"TOP OUT= "VT/10" VOLTS RANGE"QR
1003 PRINT"BOT OUT= "VB/10" VOLTS RANGE"LV
1008 REM CALC. CURRENT OUT
1010 XT=((VT/10)-D(QR))*G(QR)
1020 XB=((VB/10)-D(LV))*G(LV)
1030 RETURN

```

```

1100 REM SELECT INPUT CHANNEL
1102 CH=TH
1104 GOTO1120
1110 CH=BH
1119 REM SET AMPLIFIER RANGE
1120 POKE57343,GT
1123 REM DELAY AFTER RELAY SWITCH
1124 REM 300 COUNT LOOP IS 350 MSEC.
1125 FORI=1TO300:NEXT
1140 REM READ A/D
1145 POKE57342,CH
1150 A=57340
1155 POKEA,16
1160 POKEA,23
1165 POKEA,16
1170 IF(PEEK(57342)AND2)=2THEN1170
1172 R2=0:R3=0
1175 POKEA,24
1180 R3=PEEK(A)
1185 POKEA,25
1186 R6=PEEK(A)
1187 R7=1
1188 IF(R6AND32)=32THENR7=-1
1190 R2=(R6AND15)*256
1192 R4=(R2+R3)*(10/4096)*R7
1195 RETURN

```

```

1200 REM INTERPOLATION ROUTINE
1201 TM$=""
1202 IFRT<CC(3,1)THENTM$="<":W6$=MID$(AW$(5),2):RETURN
1204 IFRT<CC(3,84)THENTM$=">":W6$=MID$(AW$(6),2):RETURN
1206 IFRT<CC(3,15)THENI=1:GOTO1218
1208 IFRT<CC(3,30)THENI=14:GOTO1218
1210 IFRT<CC(3,45)THENI=29:GOTO1218
1212 IFRT<CC(3,60)THENI=44:GOTO1218
1214 IFRT<CC(3,75)THENI=59:GOTO1218
1216 IFRT<CC(3,84)THENI=74:GOTO1218
1218 IFRT<CC(3,I)THENIFRT<CC(3,I+1)THEN1226
1220 I=I+1
1222 IFI>84THENTM$=">":W6$=MID$(AW$(6),2):RETURN
1224 GOTO1218
1226 RU=(RT-CC(3,I))/(CC(3,I+1)-CC(3,I))
1228 TM=CC(2,I)+(CC(2,I+1)-CC(2,I))*RU
1230 TM=(INT(TM*10))/10
1232 RETURN

```

```

1240 TT$="":IFXT<CC(0,1)THENTT=0:TT$="<":GOTO1266
1242 IFXT<CC(0,84)THENTT=0:TT$=">":GOTO1266
1244 IFXT<CC(0,15)THENI=1:GOTO1250
1245 IFXT<CC(0,30)THENI=14:GOTO1250
1246 IFXT<CC(0,45)THENI=29:GOTO1250
1247 IFXT<CC(0,60)THENI=44:GOTO1250
1248 IFXT<CC(0,75)THENI=59:GOTO1250
1249 IFXT<CC(0,84)THENI=74:GOTO1250
1250 IFXT<CC(0,I)THENIFXT<CC(0,I+1)THEN1258
1252 I=I+1
1254 IFI>84THENTT=0:TT$=">":GOTO1266
1256 GOTO1250
1258 RU=(XT-CC(0,I))/(CC(0,I+1)-CC(0,I))
1259 TT=CC(2,I)+(CC(2,I+1)-CC(2,I))*RU
1260 TT=(INT(TT*10))/10
1266 BB$="":IFXB<CC(1,1)THENBB=0:BB$="<":RETURN

```

```

1267 IFXB<CC(1,84)THENBB=1:BB$=">":RETURN
1268 IFXB<CC(1,15)THENI=1:GOTO1274
1269 IFXB<CC(1,30)THENI=14:GOTO1274
1270 IFXB<CC(1,45)THENI=29:GOTO1274
1271 IFXB<CC(1,60)THENI=44:GOTO1274
1272 IFXB<CC(1,75)THENI=59:GOTO1274
1273 IFXB<CC(1,84)THENI=74:GOTO1274
1274 IFXB<CC(1,I)THENIFXB<CC(1,I+1)THEN1278
1275 I=I+1
1276 IFI>84THENBB=0:BB$=">":RETURN
1277 GOTO1274
1278 RU=(XB-CC(1,I))/(CC(1,I+1)-CC(1,I))
1280 BB=CC(2,I)+(CC(2,I+1)-CC(2,I))*RU
1282 BB=(INT(BB*10))/10
1284 RETURN

```

```

1400 REM ***** READ CLOCK ROUTINE *****
1420 SYS37913
1422 B=37988
1430 YR=PEEK(B+11)+(PEEK(B+12)*10)
1432 MO=PEEK(B+9)+(PEEK(B+10)*10)
1434 DY=PEEK(B+7)+(PEEK(B+8)*10)
1436 DA=PEEK(B+6)
1438 HR=PEEK(B+4)+((PEEK(B+5)-8)*10)
1440 MN=PEEK(B+2)+(PEEK(B+3)*10)
1442 SC=PEEK(B)+(PEEK(B+1)*10)
1446 HR$=STR$(HR)
1447 MN$=STR$(MN):IFMN<10THENMN$="0"+MN$
1448 SC$=STR$(SC):IFSC<10THENSC$="0"+SC$
1449 HS$=HR$+" "+MID$(MN$,2)+" "+MID$(SC$,2)
1450 YR$=STR$(YR)
1451 MO$=STR$(MO)
1452 DY$=STR$(DY)
1453 YD$=MID$(MO$,2)+"-"+MID$(DY$,2)+"-"+MID$(YR$,2)
1460 RETURN

```

```

1500 REM PRINTOUT ROUTINE
1504 UU=XT
1505 GOSUB1700
1506 GT#=G#:ET#=E#
1507 UU=0
1508 UU=XB
1509 GOSUB1700
1510 GB#=G#:EB#=E#
1512 FORI=1TO400:NEXT
1525 OPEN4,4,0
1530 PRINT#4,GT#:ET#;
1531 PRINT#4,CHR$(16)CHR$(49)CHR$(50)QR;
1532 PRINT#4,CHR$(16)CHR$(49)CHR$(54)GB#:EB#;
1533 PRINT#4,CHR$(16)CHR$(50)CHR$(56)LV;
1534 PRINT#4,CHR$(16)CHR$(51)CHR$(52)TT#+W1#;
1536 PRINT#4,CHR$(16)CHR$(52)CHR$(51)BB#+W2#;
1544 PRINT#4,CHR$(16)CHR$(53)CHR$(49)BT;
1546 PRINT#4,CHR$(16)CHR$(53)CHR$(57)TM#+W6#;
1548 PRINT#4,CHR$(16)CHR$(54)CHR$(56)HS#
1550 CLOSE4
1560 RETURN

```

```

1565 OPEN4,4,0
1566 PRINT#4
1567 PRINT#4,"PROBE OUTPUT AS A FUNCTION OF TIME"
1568 GOSUB1400
1569 PRINT#4,"YEAR"YR"MONTH"MO"DAY"DY
1571 PRINT#4,"CALIBRATION FILE IS "AW$(2)
1572 IFPEEK(38142)=1THEN1574
1573 PRINT#4,"ZERO READINGS TAKEN AT "NS#" HR ON "ND#:GOTO1576
1574 PRINT#4:PRINT#4,"ZERO READINGS HAVE NOT BEEN TAKEN":PRINT#4
1576 PRINT#4," TOP DIODE R BOT DIODE R (T TEMP) (B TEMP)";
1578 PRINT#4," RATIO IND.TEMP TIME"
1585 PRINT#4:CLOSE4
1590 RETURN

```

```

1700 REM ROUND OFF
1701 B#="" : BR#="" : B8#="" : BL#="" : BS#="" : BL=0 : BT#="" : WV=0 : G#="" : E#="" : P5=0
1702 B#=STR$(UU)
1712 FORI=1TO12:N$(I)="" : NEXT
1713 FORI=1TO12
1714 N$(I)=MID$(B#,I,1)
1715 IFN$(I)="" THENI=I-1:GOTO1726
1716 IFN$(I)="E" THENI=I-1:GOTO1724
1718 IFN$(I)="" THENP5=I
1720 NEXT: I=I-1
1722 GOTO1726
1724 E#=RIGHT$(B#,4)
1726 IFI>6THENIFN$(7)>"4" THENN6=VAL(N$(6)):N6=N6+1:N$(6)=MID$(STR$(N6),2)
1728 E=5:IF I<5 THENE=I
1730 G#=LEFT$(B#,E)
1732 G#=G#+N$(6)
1734 IFP5>4 THENG#=">E+2"
1740 RETURN

```

```

1800 OPEN4,4,0:CMD4
1810 PRINT"LIST OF ZERO READINGS":PRINT
1811 IFND#="" THENPRINT"ZEROS HAVE NOT BEEN TAKEN":PRINT#4:CLOSE4:RETURN
1812 PRINT"DATE "YD#" TIME "NS#:PRINT
1820 PRINT" RANGE DESCRIPTION VOLTS AMPS"
1822 PRINT
1830 FORI=1TO12
1850 PRINTCHR$(16)CHR$(48)CHR$(50)DD(I);
1851 PRINTCHR$(16)CHR$(49)CHR$(48)B$(I);
1852 PRINTCHR$(16)CHR$(50)CHR$(53)D(DD(I));
1853 PRINTCHR$(16)CHR$(52)CHR$(49)D(DD(I))*G(DD(I))
1860 NEXT
1864 PRINT#4:CLOSE4
1890 RETURN

```

```

2000 B$="":C$="":D$="":E$="":G$="2: VV=0K7=0:J$
2001 B$=STR$(UU):C$=LEFT$(B$,7)
2002 FORI=1TO8
2003 F$(I)=MID$(C$,I,1)
2004 IFF$(I)="E"THENI=I-1:GOTO2007
2005 NEXT
2007 E$=RIGHT$(B$,4)
2008 D$=LEFT$(C$,I)
2010 IFI=9THENIFF$(8)>"4"THENK7=VAL(F$(7))+1:F$(7)=MID$(STR$(K7),2)
2012 G$=D$+J$
2018 RETURN

```

```

2125 PRINTCHR$(147):PRINT:PRINT:PRINT
2126 PRINT"***** SAVE GAIN VALUES TO DISK *****"
2127 PRINT:PRINT
2128 PRINT"WILL BE SAVED UNDER NAME: "K$:PRINT
2130 PRINT
2132 INPUT"CHANGE FILE NAME TO ";K$
2133 PRINT:L$="":INPUT"TO CORRECT - ENTER Y ";L$
2134 IFL$="Y"THEN2132
2136 IFK$=""THEN2160
2140 GOTO2051
2160 PRINT:PRINT"FILE NEEDS A NAME":PRINT
2162 GOTO2132

```

```

2400 PRINTCHR$(147):PRINT:PRINT:PRINT:PRINT
2402 PRINT"*** TRANSFER SEQ. FILE DISK TO DISK ****"
2410 K$="":INPUT"ENTER NAME OF FILE";K$
2412 IFK$=""THEN100
2414 PRINT:PRINT"FILE REQUESTED IS"K$
2416 PRINT:R$="":PRINT"MAKE CHANGE IF Y";R$
2418 IFR$="Y"THEN2400
2420 PRINT:PRINT"INSERT SOURCE DISK"
2421 INPUT"PRESS RETURN WHEN READY";R$
2424 OPEN2,8,2,"0:"+K$+",S,R"
2426 FORI=1TO8
2428 INPUT#2,C$
2429 A$(I)=MID$(C$,2)
2430 NEXT
2432 CLOSE2
2440 FORI=1TO8
2442 PRINTI"  "A$(I)
2444 NEXT
2450 PRINT:R$="":INPUT"IF CORRECT FILE PRESS Y";R$
2452 IFR$="Y"THEN 2460
2454 GOTO100
2460 PRINT:PRINT"FINISHING FETCH OF DATA FROM SOURCE DISK"
2470 IFA$(1)="0"THENIFA$(3)="84"THENUU=168:GOTO2480
2472 UU=VAL(A$(3))
2480 OPEN2,8,2,"0:"+K$+",S,R"
2482 FORI=1TO8
2484 INPUT#2,MM$(I)
2486 NEXT
2488 FORI=1TOUU
2490 INPUT#2,MA(I)
2492 NEXT
2494 CLOSE2
2500 PRINT:PRINT"PLACE DESTINATION DISK IN DRIVE"
2508 PRINT:PRINT"ANY FILE NAMED * "K$" * WILL BE ERASED":PRINT
2510 R$="":PRINT:INPUT"TO CONTINUE INPUT Y ";R$
2511 IFR$=""THEN2400
2530 OPEN15,8,15,"S:"+K$
2532 CLOSE15
2540 OPEN2,8,2,"0:"+K$+",S,W"
2542 FORI=1TO8
2544 PRINT#2,MM$(I)
2546 NEXT
2548 FORI=1TOUU
2550 PRINT#2,MA(I)
2552 NEXT
2558 CLOSE2
2560 PRINT"SAVE OF SEQUENTIAL FILE IS COMPLETE"
2565 PRINT:R$="":INPUT"COPY ONTO ANOTHER DISK IF Y";R$
2566 IFR$="Y"THEN2500
2580 GOTO100

```

```

2600 REM CHECK ROUTINE FOR INTERPOLATION ROUTINE
2610 INPUT"ENTER NUMBER";XB
2620 GOSUB1267
2630 PRINT"I="I
2632 PRINT"CC(2,I)="CC(2,I)
2634 PRINT"ANSURE IS "BB
2636 GOTO2600

```

```

6000 FORI=1TO100
6010 POKE57343,0
6020 FORT=1TO300
6030 NEXT
6035 POKE57343,2
6040 FORT=1TO300
6050 NEXT
6060 GOTO6000
6080 GOTO6000

```

```

7000 INPUT"ENTER TOP RDG";TR
7005 MM=0:INPUT"MULTIPLY BY";MM
7006 AT=TR+MM*TR
7010 INPUT"ENTER BOT RDG";BR
7011 MM=0:INPUT"MULTIPLY BY";MM
7012 AB=BR+MM*BR
7018 PRINT#4,"FIRST TOP = "TR" SECOND TOP = "AT
7019 PRINT#4,"FIRST BOT = "BR" SECOND TOP = "AB
7020 PRINT#4,"RATIO = "AT/AB:RT=AT/AB
7030 GOSUB1200
7040 PRINT#4,"INDICATED TEMP= "TM
7050 PRINT#4:PRINT#4

```

```

8000 REM ***** GET DET TEMP *****
8002 GT=0:CH=5
8004 GOSUB1120
8005 PRINT"(TEMP SENS OUT = "R4*-1" )"
8006 PRINT"DET. TEMP = "<math>(\text{INT}((1000 * R4 * -1) - 2731.5)) / 10</math>" DEG C"
8008 GT=0:CH=6
8010 GOSUB1120
8012 PRINT"HTR POWER = "<math>(16/5) * R4 * -1</math>" WATTS"
8013 PRINT
8014 FORI=1TO1500:NEXT
8016 GOTO8000

```

```

30000 INPUT"ENTER NUMBER";UU
30010 GOSUB1700
30040 PRINT"G$;E$= "G$;E$
30050 GOTO30000

```

```

30100 INPUT"ENTER NUMBER";UU
30110 GOSUB2000
30140 PRINT"G$;E$="G$;E$
30150 GOTO30100
40000 OPEN15,8,15:INPUT#15,A$,B$,C$,D$
40010 PRINTA$,B$,C$,D$
40020 CLOSE15

```

# "A/D READ-M10"

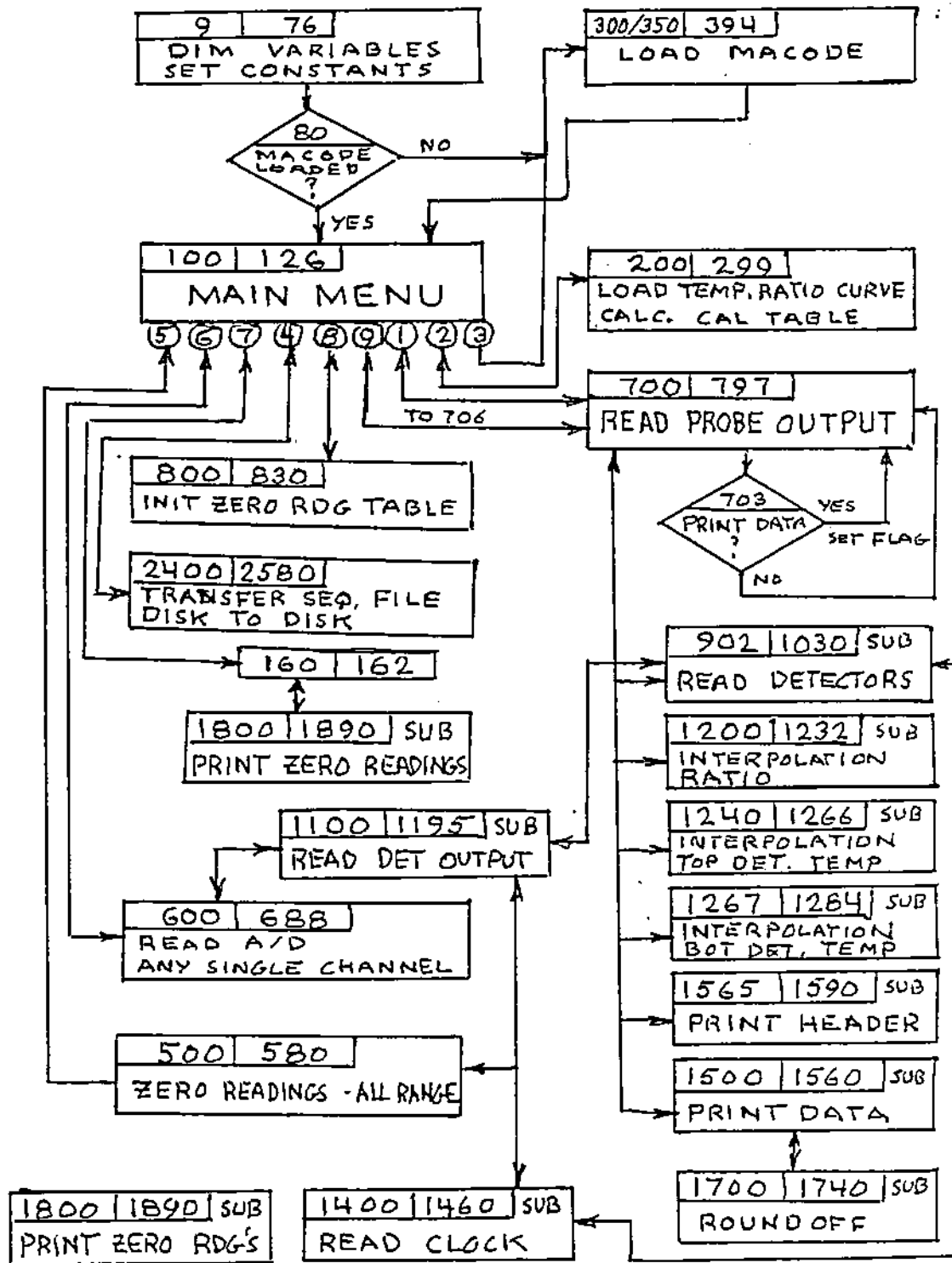



A/D READ-M10

LINE 994-997 RANGE INDICATOR	RANGE	DETECTOR	CONVERSION -	
			READ RDG -VOLTS-	AMPS/VOLT SEE LINES 29 THRU 45
QR=2	HIGH	TOP	D(2)	G(2) = 4.9531 E-6
QR=3	MEDIUM	TOP	D(3)	G(3) = 1.0255 E-7
QR=4	LOW	TOP	D(4)	G(4) = 3.1091 E-9
—	10X OUT	TOP	—	G(5) = (9.3614 E-2)*
LV=6	HIGH	BOT	D(6)	G(6) = 4.8603 E-7
LV=7	MEDIUM	BOT	D(7)	G(7) = 2.1028 E-8
LV=8	LOW	BOT	D(8)	G(8) = 9.821 E-10
—	10X OUT	BOT	—	G(9) = (9.2525 E-2)*
QR=12	HIGH * 10X	TOP	D(12)	G(12) = 1.8284 E-7
QR=13	MED. * 10X	TOP	D(13)	G(13) = 9.6001 E-9
QR=14	LOW * 10X	TOP	D(14)	G(14) = 2.9106 E-10
LV=16	HIGH * 10X	BOT	D(15)	G(16) = 4.4970 E-8
LV=17	MED. * 10X	BOT	D(16)	G(17) = 1.3456 E-9
LV=18	LOW * 10X	BOT	D(17)	G(18) = 3.0869 E-11

\* = FACTOR

GT - Value of this variable sets amplifier range - sets proper bit of output port. - Actuates relay at amp.

- GT=0, Range is LOW
- GT=1, Range is MEDIUM.
- GT=2, Range is HIGH

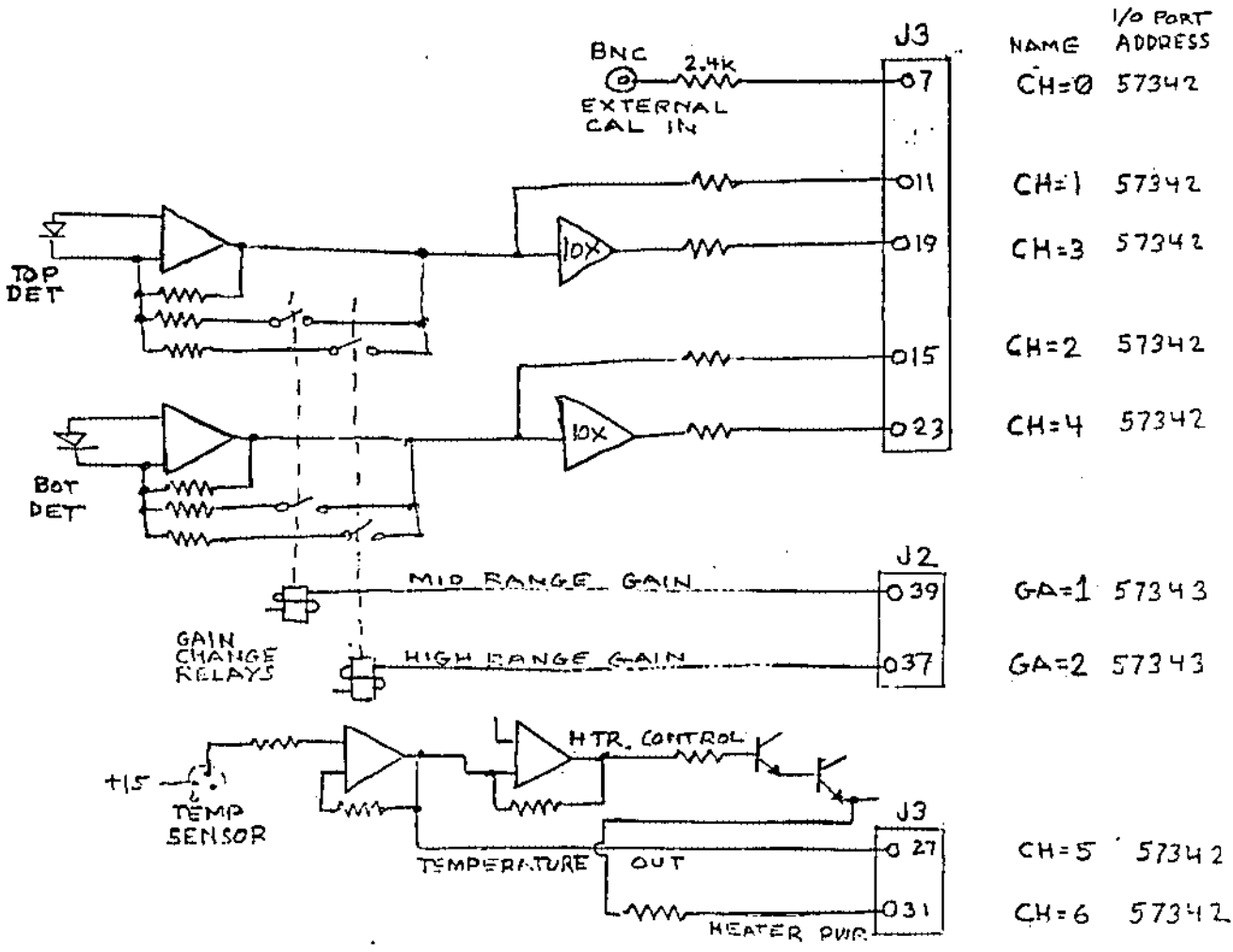

NAME	I/O PORT ADDRESS
CH=0	57342
CH=1	57342
CH=3	57342
CH=2	57342
CH=4	57342
GA=1	57343
GA=2	57343
CH=5	57342
CH=6	57342

"A/D READ-MIO"

SIMPLIFIED SENSOR DIAGRAM  
- DATA ONE CONNECTIONS -

3-11

```

1 GOTO 40100: REM A/D READ-M10
2 THIS LISTING --- "A/D READ-REM"
3 MACODE SEEMS TO BE WIPED OUT BY BASIC VARIABLES IF NOT PROTECTED.
4 COMPUTER RETURNS A LONG NUMBER OCCASIONALLY
5 .
7 .
8 .
9 .
10 .
11 .
12 .
14 .
15 .
16 .
17 .....
18 .
20 .      LISTING OF GAINS      .
21 .      OF VARIABLE GAIN AMPLIFIERS .
22 .      OF VARIABLE GAIN AMPLIFIERS .
24 .      USED WITH DETECTORS .
25 .      USED WITH DETECTORS .
26 .
27 .
28 .
29 .....
30 .
31 .      CALCULATION OF COMBINATION .
32 .      GAIN VALUES .
33 .
34 .      TWO AMPLIFIERS IN SERIES .
35 .....
64 .      B# INDICATES DET. AND GAIN .
65 .
66 .
67 .
68 .      OF(X) IS AMPLIFIER GAIN SETTING .
69 .
70 .      CF(X) IS OUTPUT PORT TO USE .
71 .
72 .      DD(X) IS NUMERIC IDENTIFICATION .
73 .      OF DET & GAIN - USED IN PRINTOUT .
74 .
75 .
76 .....
80 CHECKS FLAG TO SEE IF MACODE HAS BEEN LOADED.
81 PRINTPRINTPRINTPRINTPRINTPRINTPRINTPRINTPRINTPRINTPRINT
86 GO TO CALIBRATION CURVE LOAD ROUTINE.

```

```

100 *****
101 *
102 *      MAIN MENU      *
104 *
106 *
108 *
110 *
112 *
114 *
116 *
118 *
119 *
120 *****
122 CHECK FOR PROPER INPUT
124 CHECK FOR PROPER INPUT
126 ***** MAIN MENU ADDRESSES *****
160 DISPLAY ZERO READINGS.
162 GOTO MENU.
170 SET HARD COPY FLAGS.
171 PRINT DATA WITHOUT HEADER.
180 INIT FLAGS.
181 PRINT DATA WITH HEADER.

```

```

200 CLEAR SCREEN.
201 START OF CURVE LOAD ROUTINE.
202 DEFAULT FILE NAME.
203 DISPLAY REMINDER.
204 .....
205 . OPTION TO CHANGE NAME OR .
206 . TO BYPASS LOAD OF FILE .
207 .
208 .....
210 GOTO MENU.
211 .
212 .
213 .
220 GIVES TIME TO INSERT DISK INTO DRIVE.
222 .
225 OPEN FILE.
228 .....
230 . READ EIGHT ITEM HEADER .
232 .
234 .....
235 CLOSE FILE.
236 VERIFY THAT FILE WAS FOUND - IF NOT FOUND THEN START OVER.
238 .....
239 .
240 . DISPLAY FILE HEADER .
241 .
242 .....
245 REOPEN FILE.
246 .....
247 . REREAD FILE HEADER .
249 .
251 .
252 . READ FILE DATA .
254 .
256 .
258 .....
260 CLOSE FILE.
261 VARIABLE = BOTTOM TEMP IN TABLE * FIND IN HEADER LINE 4
262 VARIABLE = TABLE TEMP INCREMENT * FIND IN HEADER LINE 4
263 VARIABLE = TOP TEMP IN TABLE * FIND IN HEADER LINE 4
264 .....
265 . CALCULATE RATIO VALUES .
266 .
268 .
269 . (BYPASS DISPLAY) .
270 .
272 .
274 .....
275 .
276 DISPLAY LOWEST RATIO IN TABLE.
278 DISPLAY HIGHEST RATIO IN TABLE.
280 TIME DELAY FOR VIEWING OF ABOVE.
299 GOTO MAIN MENU.

```

```

300 CLEAR SCREEN.
302 "MACODE" IS A MACHINE LANGUAGE PROGRAM THAT
303 ENABLES USE OF I/O PORT AND CLOCK.
320 THIS PROGRAM WAS SUPPLIED BY THE SUPPLIER OF THE PORT.
330 .
332 .
333 .
350 . MMESSAGE IS NOT CORRECT.
351 SET FLAG INDICATING THAT MACODE HAS BEEN LOADED.
352 .....
354 . LOAD FILE HEADER .
355 .
356 .
357 .
358 . (CHECK TO VERIFY THAT .
359 . (STARTING ADDRESS) .
360 .

```

```

362 .
364 . LOAD CODE STARTING AT .
365 . ABOVE ADDRESS. .
366 . .
368 .....
386 CHECK FLAG.
387 GO TO MAIN MENU IF FLAG NOT= TO LD.
390 ESCAPE IF DESIRED.
392 TRY ANOTHER DISK.

```

```

500 CLEAR SCREEN
502 GET ZERO READINGS ON ALL RANGES.
504 .
530 * SET AMPLIFIER GAIN (AT PORT)
532 * TIME DELAY TO LET AMPLIFIER SETTLE.
533 * INIT. OUTPUT REG.
534 * MAKE 12 READINGS ON EACH RANGE.
535 * CHANNEL TO BE READ.
536 * SROUTINE READS OUTPUT OF DETECTOR.
537 * DISCARD FIRST TWO READINGS.
538 * KEEP SUM OF READINGS.
540 * DISPLAY READINGS AS MADE.
542 *
546 * CALC. AVERAGE OF 10 READINGS AND STORE RESULT.
547 * DISPLAY RESULT.
550 END OF READ ROUTINE.
552 .....
554 .
555 . DISPLAY SUMMARY TABLE .
556 . OF ZERO READINGS. .
558 .....
567 .
569 READ TIME FROM CLOCK ON I/O PORT.
570 SET FLAG THAT INDICATES THAT ZERO READINGS HAVE BEEN TAKEN.
571 STORE TIME OF END OF READINGS.
572 .
574 IF DOING OVER RESET FLAG.
576 HARD COPY PRINT
578 IF YES - HARD COPY ROUTINE.
580 GOTO MAIN MENU

```

```

600 .
602 ***** READ INDIVIDUAL RANGE *****
604 .....
606 . DISPLAY SELECTION MENU .
610 . .
612 . B*(X) IS DEFINED IN LINES 64 .
614 . THROUGH 76 .
616 . .
618 . .
620 .....
621 .
622 SELECT RANGE TO READ.
624 .
625 IF OUT OF RANGE START OVER
641 NOT NEEDED
642 SETUP GAIN AND CHANNEL
660 .
662 MAKE ONE READING
666 .....
668 . DISPLAY .
669 . RANGE - AMPS - VOLTS .
670 . .
671 . .
672 .....
680 .
682 .
688 .

```

```

700 .
701 .
702 WHEN ZERO RDGS. TAKEN FLAG IS SET AT ADDRESS 38142
703 SELECT DISPLAY OR HARD COPY.
704 SET FLAG
705 IF HARD COPY NOT WANTED THEN READY TO READ.
706 PRINT HARD COPY HEADER.
707 READY TO READ ON COMMAND.
708 .
709 .
712 DISPLAY RESULT.
717 SELECT PROPER RANGE AND READ OUTPUTS.
722 DISPLAY RESULT.
724 PREVENT DIVISION BY ZERO.
726 .
728 .
730 CALC. RATIO.
732 ROUND OFF RATIO.
744 DISPLAY RATIO.
745 LOOK UP TEMPERATURE - INTERPOLATION ROUTINE.
747 LOOK UP TEMPERATURE INDICATED BY INDIVIDUAL DETECTORS.
748 ** AW$(X) ARE FILE HEADER ITEMS LOADED IN LINE 232
749 .   AW$(5) IS BOTTOM TEMP OF CAL. *
754 .   *
755 .   AW$(6) IS TOP TEMP OF CAL.   *CHECK THESE OUT*****
762 .   *
764 .   *
766 .   AW$(3) IS TABLE LENGTH
767 .   AW$(4) IS
768 .
780 DISPLAY DATA.
781 .
783 FLAG=0 - DON'T PRINT
784 PRINT DATA
785 PROVISION FOR CONTINUOUS READOUT. HAVE TO EXIT PROGRAM TO SET WW
786 MUST REENTER PROGRAM WITH A GOTO 700 OR GOTO 100 ETC.
787 .
788 RESTARTS READ CYCLE.
790 NOT USED PRINT
794
796
797

800 .....
810 .
812 . SET ALL ZERO .
814 .
816 . READINGS .
820 .
822 . TO ZERO .
824 .
826 .....
829 RESET ZERO READING FLAG.
830 GOTO MAIN MENU.

900 *** FIND AMPLIFIER GAIN ROUTINE ***
902 SET GAIN AND AMP. COMBINATION TO MAX. GAIN.
904 MAKE READING.
906 IF OUTPUT GREATER THAN 9 THEN GO TO NEXT LESS SENSITIVE COMBINATION.
908 IF OUTPUT LESS THAN 9 THEN CHECK BOTTOM DET. OUTPUT
910 .
912 .
914 .
916 .
918 .
920 .
922 .
924 .
926 .
928 .
930 .
932 .

```

```

936 .
938 .
940 .
942 .
944 .
946 .
947 .
948 TIME DELAY.
950 START - SELECT GAIN FOR BOTTOM DETECTOR.
951 .
952 READ CLOCK - TIME OF START OF DATA READ.
954 .
956 .
958 .
970 .
971 READ ONE, THEN THE OTHER DETECTOR AND REPEAT TEN TIMES.
972 .
973 SET CHANNEL FOR BOTTOM DET.
974 READ BOT. DETECTOR.
975 IF AMP NEAR SATURATION - GOTO MENU.
977 VB IS SUM OF OUTPUTS.
979 SET CHANNEL FOR TOP DET.
980 READ TOP DET.
982 IF AMP NEAR SATURATION - GOTO MENU.
984 VT IS SUM OF TOP DET. READINGS.
990 .
991 GAIN SUBSCRIPTS IDENTIFY AMPLIFIERS AND GAIN SETTINGS.
993 .
994 .
995 .
996 .
997 .
1002 DISPLAY AVERAGE OUTPUT OF TOP DET.
1003 DISPLAY AVERAGE OUTPUT OF BOT.DET.
1008 .
1010 CALC. TOP DET. CURRENT.
1020 CALC. BOT. DET. CURRENT.
1030 .

```

```

1100 **** START OF DET. READ ROUTINE. ****
1102 INPUT TOP DET. CHANNEL.
1104 .
1110 INPUT BOT. DET. CHANNEL.
1119 .
1120 SET AMPLIFIER GAIN.
1123 .
1124 .
1125 .
1140 .
1145 SET CHANNEL.....
1150 . I/O PORT READS DET. OUTPUT .
1155 . DISABLE DDAD REGISTER.. .
1160 . START A/D.. .
1165 . RESET START FLIP FLOP.. .
1170 . WAIT FOR DATA.. .
1172 . INIT VARIABLES .
1175 . ENABLE LOW BYTE ONTO BUSS.. .
1180 . READ LOW BYTE.. .
1185 . ENABLE A/D HI BYTE.. .
1186 . READ HI BYTE.. .
1187 . INIT SIGN FLAG.. .
1188 . TEST FOR SIGN OF ANSWER.. .
1190 . GET RID OF HIGH NIBBLE.. .
1192 . CALCULATE SIGNED DECIMAL ANS..
1195 .....

```

```
1200 .....
1201 . INTERPOLATION ROUTINE FOR .
1202 . RATIO TABLE. .
1204 .
1206 . HUNTS FOR APPROXIMATE PART .
1208 . OF TABLE AND THEN DOES A .
1210 . STRAIGHT LINE INTERPOLATION..
1212 .
1214 .
1216 .**TAKES RATIO OF DETECTOR .
1218 . OUTPUTS AND LOOKS UP TEMP.**.
1220 .
1222 .
1224 .
1226 .
1228 .
1230 . ....ROUND OFF OF TEMPERATURE. .
1232 .....
```

```
1240 .....
1242 .
1244 . LOOK UP IND.TEMP OF TOP DET. .
1245 .
1246 . STRAIGHT LINE INTERPOLATION .
1247 .
1248 .
1249 .
1250 .
1252 .
1254 .
1256 .
1258 .
1259 . TT IS INDICATED TEMP OF TOP DET..
1260 .
1266 .....
```

```
1267 .....
1269 .
1270 . LOOK UP IND. TEMP OF BOT. DET. .
1271 . STRAIGHT LINE INTERPOLATION. .
1272 .
1273 .
1274 .
1275 .
1276 .
1277 .
1278 .
1280 .
1282 .
1284 .....
```

```
1400 ***** READ CLOCK ROUTINE *****
1420 .....
1422 .
1430 . CLOCK IS ON I/O PORT BOARD. .
1432 .
1436 . DATA MUST BE READ OUT AS .
1438 . INDICATED ON LINES 1430 THRU .
1440 . 1442. .
1442 .
1446 .
1448 . DATA IS THEN CONVERTED TO .
1449 . STRING VALUES FOR USE BY THE .
1450 . PROGRAM. .
1451 .
1452 .
1453 .
1460 .....
```



```

1500 **** HARD COPY PRINT ROUTINE ****
1504 SET VALUE OF UU TO TOP DET OUT.
1505 ROUNDOFF UU
1506 ANSWER RETURNS AS G$ AND AS EXPONENT E$
1507 NOT NEEDED.
1508 SET VALUE OF UU TO BOT. DET OUT.
1509 ROUNDOFF UU
1510 ANSWER RETURNS AS G$ AND AS EXPONENT E$
1512 DELAY LOOP.
1525 OPEN PRINTER TO PRINT DATA.
1530 . FOLLOWING CHR$ COMMANDS FOR 801 PRINTER.
1531 . TAB(12) FROM START OF LINE !!!
1532 . TAB(16)
1533 . TAB(28) CHR$(16) INDICATES THAT NEXT CHR$ VALUES
1534 . TAB(34) ARE TAB VALUES RELATIVE TO START OF LINE.
1536 . TAB(43)
1544 . TAB(51)
1546 . TAB(59)
1548 . TAB(68)
1550 CLOSE PRINTER.
1560 .

```

```

1565 OPEN PRINTER TO PRINT HEADER.
1566 .
1567 .
1568 READ THE CLOCK (TIME OF DAY)
1569 .
1571 .
1572 CHECK ADDRESS TO SEE IF FLAG INDICATES ZERO RDGS TAKEN.
1573 .
1574 .
1576 .
1578 .
1585 CLOSE PRINTER.
1590 .

```

```

-----
1700 ***** ROUNDOFF ROUTINE *****
1701 . INIT VARIABLES
1702 . CONVERT UU TO A STRING
1712 . INIT 12 LINE TABLE
1713 .....
1714 . FIND IF EXPONENT USED .
1715 . LOCATE DECIMAL POINT .
1716 . FIND LENGTH OF NUMBER .
1718 . .
1720 .....
1722 .
1724 . E$=EXPONENT IE E-19
1726 . ROUND LAST NUMBER UP OR DOWN AS NEEDED.
1728 .
1730 . GET 5 CHARACTER MANTISSA.
1732 . ADD 6TH CHARACTER.
1734 . PRINTPRINTPRINTPRINT
1740 ↑↑↑↑↑↑ END OF ROUNDOFF ↑↑↑↑↑↑

```

```

1800 **** OPEN PRINTER TO PRINT ZERO READINGS ****
1810 .
1811 IF ZERO READINGS HAVE NOT BEEN TAKEN DO NOT CONTINUE. CLOSE.
1812 .
1820 .
1830 .
1850 . TAB(2)
1851 . TAB(10)
1852 . TAB(25)
1853 . TAB(41)
1860 .
1864 CLOSE.
1890 ↑↑↑↑↑ END OF PRINT ROUTINE ↑↑↑↑↑

```

```

2000 .....
2001 .
2002 . NUMBER ROUNDOFF ROUTINE - .
2003 .
2004 . DOES NOT ALWAYS WORK DUE TO .
2005 .
2007 . STORAGE METHOD USED BY .
2008 .
2010 . COMPUTER. .
2012 .
2018 .....

```

```

2125 .
2126 .....
2127 .
2129 . ROUTINE INCOMPLETE - .
2130 .
2132 .
2133 .
2134 .
2136 .
2140 .
2160 .
2162 .....

```

```

2400 .
2402 ***** COPY FILE ROUTINE ***** UTILITY ROUTINE **
2410 .
2412 IF NO ENTRY GO TO MAIN MENU.
2414 VERIFIES FILE NAME OF FILE TO BE LOADED FROM DISK
2416 CHANCE TO CHANGE ERROR
2418 .
2420 .
2421 .
2424 OPEN FILE TO READ FROM DISK.
2426 READ 8 STRING FILE HEASER.
2428 .
2429 ...REMOVE FIRST CHARACTER OF STRING.
2430 .
2432 CLOSE FILE.
2440 DISPLAY FILE HEADER.
2442 .
2444 .
2450 ESCAPE OPTION.
2453 .
2454 GOTO MAIN MENU.
2460 .
2470 CHECK FOR FILE FORMAT AND ID.
2472 FILE LENGTH.
2480 OPEN FILE TO READ FROM DISK.
2482 REREAD FILE HEADER.
2484 .
2486 .
2488 READ DATA.
2490 .
2492 .
2494 CLOSE FILE.
2500 CHANGE DISKS IF DESIRED.
2508 CONFIRMS FILE NAME.
2510 ESCAPE OPTION.
2511 .
2530 OPEN COMMAND CHANNEL AND ERASE FILE OF SAME NAME.
2532 CLOSE COMMAND CHANNEL.
2540 OPEN FILE FOR OUTPUT TO DISK.
2542 WRITE FILE HEADER.
2544 .
2546 .
2548 WRITE DATA. UU IS NUMBER OF DATA ITEMS.
2550 .
2552 .
2558 CLOSE FILE.
2560 .
2563 .
2566 .
2580 GOTO MAIN MENU.

```

```
2600 ** START OF SOME TROUBLESHOOTING ROUTINES.
2610 . **
2620 . **
2630 . **
2632 . **
2634 . **
2636 ..... **.....
```

```
6000 . **
6020 . **
6030 . **
6035 . **
6040 . **
6050 . **
6060 . **
6080 ..... **.....
```

```
7000 . **
7010 . **
7011 . **
7012 . **
7018 . **
7019 . **
7020 . **
7030 . **
7040 . **
7050 ..... **.....
```

```
8000 ***** READ TEMPERATURE OF DETECTOR *****
8002 SET GAIN AND CHANNEL.
8004 READ SENSOR OUTPUT.
8005 DISPLAY TEMP IN DEG. K
8006 DISPLAY TEMP IN DEG. C
8008 SET GAIN AND CHANNEL TO READ HEATER POWER.
8010 **** READ HEATER POWER.
8012 DISPLAY POWER.
8013 .
8014 TIME DELAY TO READ NUMBER.
8016 READ TEMP. AND POWER AGAIN.
```

```
30000 ** CHECK INTERPOLATION ROUTINE. **
30010 .
30040 DISPLAY ANSWER.
```

```
30100 ** CHECK INTERPOLATION ROUTINE. **
30110 .
30140 DISPLAY ANSWER.
30150 TRY AGAIN.
40000 ***** READ DISK ERROR DATA. *****
40010 DISPLAY DISK STATUS.
```

```

1200 REM INTERPOLATION ROUTINE
1210 IF RT < CC(6,1) THEN TM=0:PRINT"UT":GOTO1270
1212 IF RT > CC(6,84) THEN TM=0:PRINT"OT":GOTO1270
1220 IF RT < CC(6,15) THEN I=0:GOTO1256
1222 IF RT < CC(6,30) THEN I=14:GOTO1256
1224 IF RT < CC(6,45) THEN I=29:GOTO1256
1226 IF RT < CC(6,60) THEN I=44:GOTO1256
1228 IF RT < CC(6,75) THEN I=59:GOTO1256
1230 IF RT < CC(6,84) THEN I=74:GOTO1256
1252 I=I+1
1253 IF I > 84 THEN 1266
1254 GOTO1250
1256 IF RT < CC(6,I) THEN IF RT < CC(6,I+1) THEN 1262
1257 I=I+1
1258 IF I > 84 THEN 1266
1259 GOTO1256
1262 RU=(RT-CC(6,I))/(CC(6,I+1)-CC(6,I))
1263 TM=CC(5,I)+((CC(5,I+1)-CC(5,I))*RU)
1264 TM=(INT(TM*10))/10
1265 GOTO1270
1266 TM=0
1270 RETURN
    
```

} test for ratio out of range

} Coarse search

} Fine search

TM = indicated temperature.  
Reduce number of characters in answer

READY.

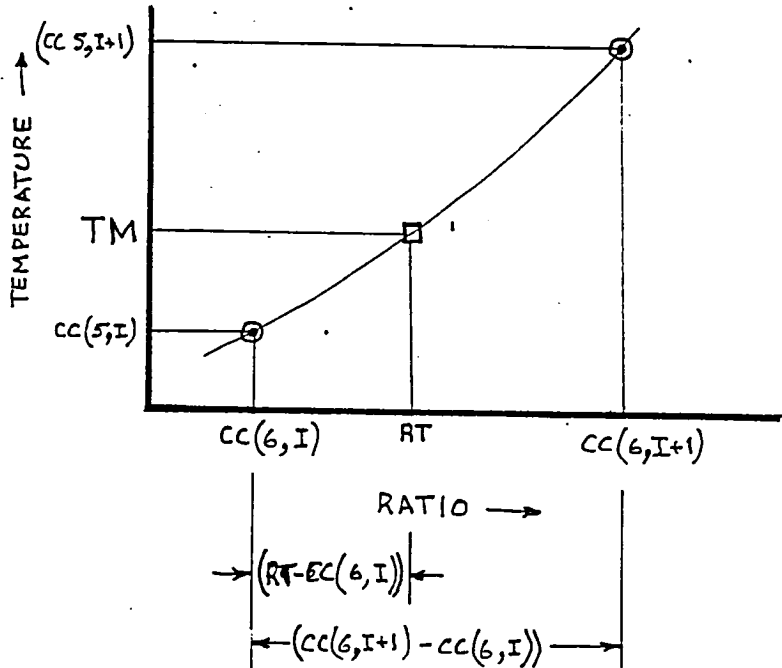

PROGRAM 'A/D READ-M10' - 5/17/85 - REMARKS

```
1400 REM ***** READ CLOCK ROUTINE *****
1420 SYS37913      — USES "MACODE" TO LOOK AT CLOCK
1422 B=37888
1430 YR=PEEK(B+11)+(PEEK(B+12)*10)
1432 MO=PEEK(B+9)+(PEEK(B+10)*10)
1434 DY=PEEK(B+7)+(PEEK(B+8)*10)
1436 IA=PEEK(B+6)
1438 HR=PEEK(B+4)+((PEEK(B+5)-8)*10)
1440 MN=PEEK(B+2)+(PEEK(B+3)*10)
1442 SC=PEEK(B)+(PEEK(B+1)*10)
1460 RETURN
```

} OUTPUT MUST BE READ IN THIS ORDER  
EVEN IF ONLY THE TIME IS WANTED

READY.

```

1500 REM PRINTOUT ROUTINE
1505 OPEN4,4,0
1530 PRINT#4,CHR$(16)CHR$(48)CHR$(49) XT; TAB 1
1531 PRINT#4,CHR$(16)CHR$(49)CHR$(55) QR; TAB 17
1532 PRINT#4,CHR$(16)CHR$(50)CHR$(50) XB; TAB 22
1533 PRINT#4,CHR$(16)CHR$(51)CHR$(55) LV; TAB 37
1534 PRINT#4,CHR$(16)CHR$(52)CHR$(52) RT; TAB 44
1536 PRINT#4,CHR$(16)CHR$(53)CHR$(52) TM; TAB 54
1538 PRINT#4,CHR$(16)CHR$(54)CHR$(53)HR;MN;SC TAB 65
1550 CLOSE4
1560 RETURN
    
```

CHR\$(16) identifies that next two values are tab values.

CHR\$(48)=0 :  
 CHR\$(49)=1 :  
 CHR\$(50)=2 :  
 etc

Tab value for printer

READY.

```

1565 OPEN4,4,0
1566 PRINT#4
1570 PRINT#4," TOP DIODE RANGE BOTTOM DIODE RANGE RATIO";
1571 PRINT#4," IND. TEMP TIME"
1580 PRINT#4
1585 PRINT#4:CLOSE4
1590 RETURN
1599 STOP
    
```

READY.

ZERO LEADING HAVE NOT BEEN TAKEN  
 XX XC YV  
 YR MO DAY

Sample printout

TOP DIODE	RANGE	BOTTOM DIODE	RANGE	RATIO	IND. TEMP	TIME
				0	9	12 9
				0	9	12 28
				0	9	12 35
				0	9	12 43
2.58510532E-10	14	5.76803922E-12	18	44.8177		
2.5680513E-10	14	5.76803922E-12	18	44.522		
2.5723148E-10	14	5.76803922E-12	18	44.596		
2.5723148E-10	14	5.72366969E-12	18	44.9417		

Zero indicates out of range or no ratio table loaded

HR (24hr time) MIN SEC

```

1800 OPEN4,4,0:CMD4
1810 PRINT"LIST OF ZERO READINGS":PRINT:PRINT:PRINT:PRINT
1820 PRINT"D("ZZ")      RANGE          VOLTS"
1830 FORI=1TO12
1832 IFI=1THENZZ=14:K$="TOP LOW*10X":GOTO1849
1833 IFI=2THENZZ=4:K$="TOP LOW":GOTO1849
1834 IFI=3THENZZ=13:K$="TOP MED*10X":GOTO1849
1835 IFI=4THENZZ=3:K$="TOP MED":GOTO1849
1836 IFI=5THENZZ=12:K$="TOP HI*10X":GOTO1849
1837 IFI=6THENZZ=2:K$="TOP HI":GOTO1849
1838 IFI=7THENZZ=18:K$="BOT LOW*10X":GOTO1849
1839 IFI=8THENZZ=8:K$="BOT LOW":GOTO1849
1840 IFI=9THENZZ=17:K$="BOT MED*10X":GOTO1849
1841 IFI=10THENZZ=7:K$="BOT MED":GOTO1849
1842 IFI=11THENZZ=16:K$="BOT HI*10X":GOTO1849
1843 ZZ=6:K$="BOT HI"
1849 PRINT
1850 PRINTCHR$(16)CHR$(48)CHR$(50)ZZ;
1851 PRINTCHR$(16)CHR$(49)CHR$(48)K$;
1852 PRINTCHR$(16)CHR$(50)CHR$(53)D(ZZ)
1860 NEXT
1864 PRINT#4:CLOSE4
1890 RETURN
    
```

Printer tab command

READY.

LIST OF ZERO READINGS		
D( 6 )	RANGE	VOLTS
14	TOP LOW*10X	.712402344
4	TOP LOW	.0005664063
13	TOP MED*10X	.0366210938
3	TOP MED	.0146484375
12	TOP HI*10X	.0170898438
2	TOP HI	.0122070313
18	BOT LOW*10X	.0366210938
8	BOT LOW	.0170898438
17	BOT MED*10X	9.765625E-03
7	BOT MED	.0122070313
16	BOT HI*10X	9.765625E-03
6	BOT HI	.0122070313

Sample of printout

SEQ. FILE 'MACODE' WHICH IS USED BY THE I/O PORT.

THE FOLLOWING IS A LISTING OF THE DATA PORTION OF SEQ. FILE NAMED  
'MACODE' DECIMAL ADDRESS AND DECIMAL EQUIV. OF CODE ARE GIVEN.

37889	- 2	37945	- 223	38001	- 0	38057	- 141	38114	- 5
37890	- 2	37946	- 234	38002	- 148	38058	- 161	38115	- 141
37891	- 1	37947	- 234	38003	- 141	38059	- 148	38116	- 252
37892	- 4	37948	- 234	38004	- 253	38060	- 72	38117	- 223
37893	- 9	37949	- 234	38005	- 223	38061	- 173	38118	- 169
37894	- 1	37950	- 234	38006	- 169	38062	- 160	38119	- 0
37895	- 3	37951	- 234	38007	- 2	38063	- 148	38120	- 141
37896	- 1	37952	- 173	38008	- 141	38064	- 41	38121	- 252
37897	- 5	37953	- 252	38009	- 252	38065	- 15	38122	- 223
37898	- 0	37954	- 223	38010	- 223	38066	- 141	38123	- 96
37899	- 5	37955	- 41	38011	- 234	38067	- 253	38124	- 72
37900	- 8	37956	- 15	38012	- 234	38068	- 223	38125	- 169
37901	- 255	37957	- 157	38013	- 234	38069	- 32	38126	- 20
37902	- 0	37958	- 0	38014	- 169	38070	- 225	38127	- 141
37903	- 72	37959	- 148	38015	- 0	38071	- 148	38128	- 252
37904	- 173	37960	- 169	38016	- 141	38072	- 173	38129	- 223
37905	- 254	37961	- 10	38017	- 252	38073	- 160	38130	- 169
37906	- 223	37962	- 141	38018	- 223	38074	- 148	38131	- 16
37907	- 41	37963	- 252	38019	- 138	38075	- 41	38132	- 141
37908	- 1	37964	- 223	38020	- 208	38076	- 240	38133	- 252
37909	- 240	37965	- 138	38021	- 216	38077	- 24	38134	- 223
37910	- 249	37966	- 208	38022	- 169	38078	- 106	38135	- 104
37911	- 104	37967	- 211	38023	- 16	38079	- 106	38136	- 96
37912	- 96	37968	- 104	38024	- 141	38080	- 106	38137	- 255
37913	- 72	37969	- 170	38025	- 252	38081	- 106	38138	- 0
37914	- 138	37970	- 104	38026	- 223	38082	- 9	38139	- 0
37915	- 72	37971	- 96	38027	- 104	38083	- 16	38140	- 85
37916	- 169	37972	- 72	38028	- 170	38084	- 141	38141	- 191
37917	- 0	37973	- 138	38029	- 104	38085	- 253	38142	- 9
37918	- 141	37974	- 72	38030	- 96	38086	- 223	38143	- 196
37919	- 252	37975	- 169	38031	- 0	38087	- 32		
37920	- 223	37976	- 0	38032	- 255	38088	- 225		
37921	- 162	37977	- 141	38033	- 255	38089	- 148		
37922	- 13	37978	- 252	38034	- 0	38090	- 173		
37923	- 202	37979	- 223	38035	- 0	38091	- 161		
37924	- 142	37980	- 162	38036	- 255	38092	- 148		
37925	- 253	37981	- 13	38037	- 255	38093	- 41		
37926	- 223	37982	- 202	38038	- 0	38094	- 15		
37927	- 32	37983	- 142	38039	- 0	38095	- 9		
37928	- 15	37984	- 253	38040	- 255	38096	- 32		
37929	- 148	37985	- 223	38041	- 255	38097	- 141		
37930	- 169	37986	- 32	38042	- 0	38098	- 253		
37931	- 1	37987	- 15	38043	- 0	38099	- 223		
37932	- 141	37988	- 148	38044	- 255	38100	- 32		
37933	- 252	37989	- 169	38045	- 255	38101	- 225		
37934	- 223	37990	- 1	38046	- 0	38102	- 148		
37935	- 234	37991	- 141	38047	- 0	38103	- 169		
37936	- 169	37992	- 252	38048	- 255	38104	- 48		
37937	- 16	37993	- 223	38049	- 87	38105	- 141		
37938	- 141	37994	- 234	38050	- 169	38106	- 253		
37939	- 252	37995	- 169	38051	- 255	38107	- 223		
37940	- 223	37996	- 0	38052	- 141	38108	- 32		
37941	- 169	37997	- 141	38053	- 160	38109	- 225		
37942	- 19	37998	- 252	38054	- 148	38110	- 148		
37943	- 141	37999	- 223	38055	- 169	38111	- 104		
37944	- 252	38000	- 189	38056	- 255	38112	- 96		
						38113	- 169		

THIS PROGRAM SUPPLIED BY CGRS MICROTECH - MFG. OF I/O PORT  
THIS LIST IS FOR TROUBLESHOOTING PURPOSES ONLY



APPENDIX D4  
COMPUTER PROGRAM PM-TEMP4A

FLOW CHART FOR PROGRAM 'UTCCR1'  
 - 'PM-TEMP4A' HAS THE SAME CALCD. ROUTINES

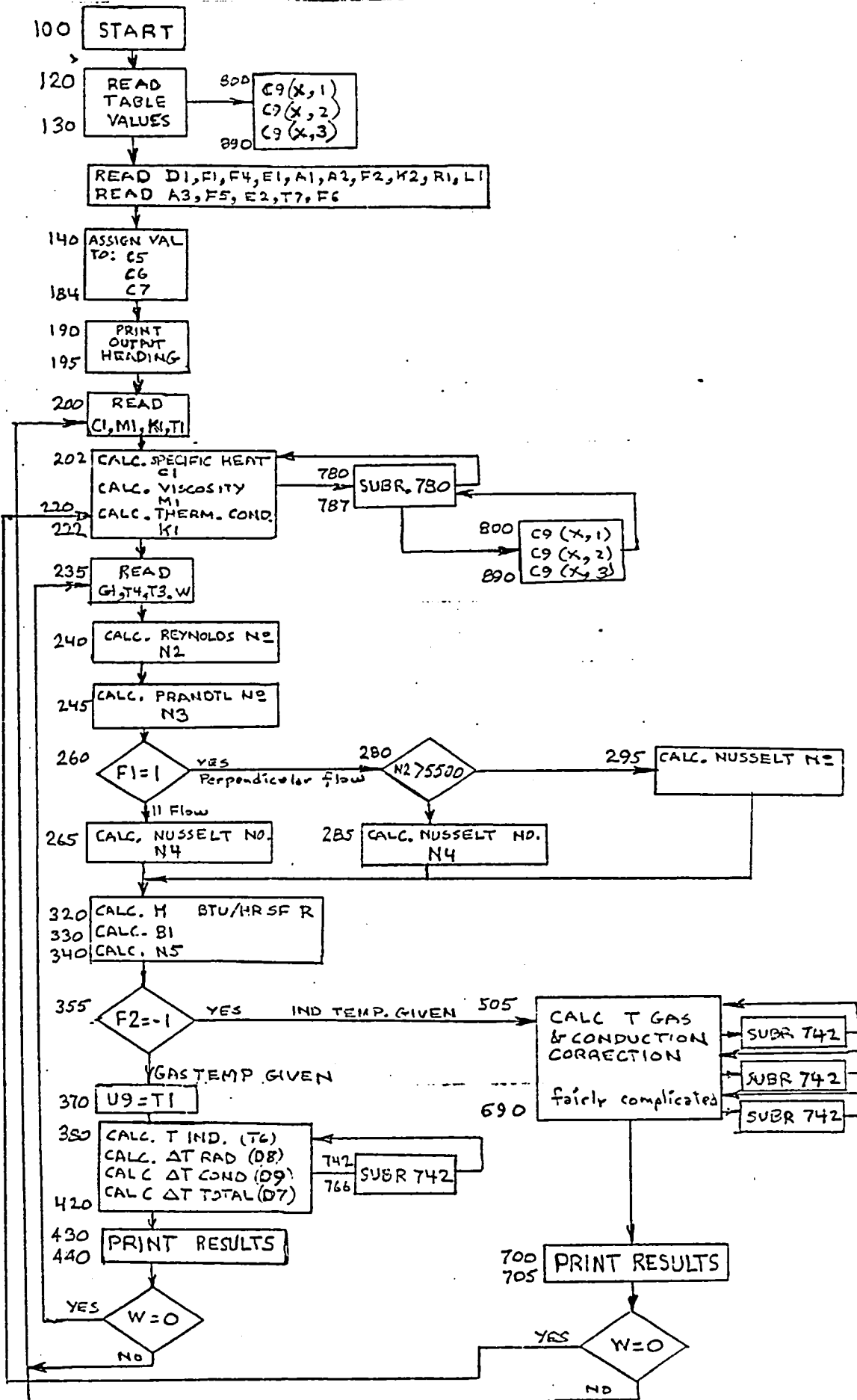

```

10001 REM PROGRAM - PM-TEMP4A - TEMPERATURE CORRECTION ROUTINE
10002 REM DATE: 11/07/85
10003 DIMA$(93)
10004 REM CALC. ROUTINE ENDS AT LINE 10470
10005 PRINTCHR$(147):PRINT:PRINT
10006 PRINT:PRINTTAB(9)"PROGRAM * PM-TEMP4A *":PRINT:PRINT
10007 PRINTTAB(5) "THERMOCOUPLE CORRECTION ROUTINE"
10008 REM ** PRINTOUT ACCESSED FROM LINE 11152 **
10009 FORI=1TO300:NEXT:PRINT:PRINT
10010 PRINTTAB(9)"ENTERING TABLE DATA "
10011 REM
10013 DIMC9(42,3)
10014 FORI3=1TO3
10015 FORI2=1TO42
10016 READC9(I2,I3)
10017 NEXTI2
10018 NEXTI3
10020 GOSUB12001
10021 PRINT:PRINT:PRINTTAB(9)"LOADING DEFAULT DATA"
10022 GOSUB12230
10024 PRINT:PRINT:PRINT
10028 PRINTTAB(2)"UNLESS OTHERWISE CALCULATION WILL BE MADE:)"
10029 PRINTTAB(7);
10030 ZZ$="":INPUT"ENTER Y TO EDIT INPUT ";ZZ$
10031 IFZZ$>"Y"THEN12100
10091 PRINT CHR$(147):PRINT:PRINT:PRINT:PRINT:PRINT
10097 PRINTCHR$(147):PRINT:PRINT:PRINT
10099 PRINT" CORRECTION FOR UNCOATED TC":PRINT
10100 PRINT " PROGRAM IS NOW RUNNING":PRINT " PLEASE WAIT FOR RESULTS"
10101 REM UTCCR1 IS ORIGINAL PROGRAM
10102 PRINT:PRINT
10142 IFF2=0THEN10155
10145 PRINT"INDICATED TEMPERATURE WAS GIVEN"
10150 GOTO10158
10155 PRINT"GAS TEMPERATURE WAS GIVEN"
10158 F9=1
10163 C6=.15
10165 IFF1=1THEN10172
10167 PRINT" C6= "C6:PRINT
10170 GOTO10202
10172 IFF9=2THEN10182
10175 C7=1.11
10177 PRINT" C7= "C7"CONSTANT MULTIPLIER":PRINT
10180 GOTO10202
10182 C5=.477
10184 PRINT" C5= "C5:PRINT
10200 REM
10202 IFC1=0THEN10210
10203 IFM1=0THEN10215
10204 IFK1=0THEN10220
10205 GOTO10235
10210 K9=1
10211 GOSUB10780
10212 C1=C8
10213 GOTO10203
10215 K9=2
10216 GOSUB10780
10217 M1=C8
10218 GOTO10204
10220 K9=3
10221 GOSUB10780
10222 K1=C8
10235 REM READ G1,T4,T3,W
10240 N2=300*G1*W1/M1
10245 N3=C1*M1/K1
10260 IFF1=1THEN10275
10265 N4=C6*(N2↑(2/3))*N3↑(1/3)
10267 GOTO10320
10275 IFF9=2THEN10305
10280 IFN2>5500THEN10295
10285 N4=.43+C7*.48*SQR(N2)*N3↑.31)
10290 GOTO10320
10295 N4=.43+C7*.174*(N2↑.618)*N3↑.31)
10300 GOTO10320

```

```

10305 N4=C5*SQR(N2)*(N3↑.3)
10320 H=12*(N4)*K1/D1
10330 B1=.173*F4*E1*A1*D1/(N4*K1*A2*12)
10340 N5=144*N4*K1/(K2*R1↑2)
10355 IFF2=-1THEN10505
10370 U9=T1
10380 GOSUB10742.
10390 T6=U6
10400 D8=U8
10410 D9=V9
10420 D7=U7
10430 PRINT"GAS FLOW..... = "G1
10431 PRINT"INDICATED TEMP.. = "T6
10432 PRINT"GAS TEMP..... = "T1
10433 PRINT"DELTA T - RAD... = "D8
10434 PRINT"DELTA T - COND.. = "D9
10435 PRINT"TOTAL DEL. T.... = "D7
10436 PRINT"H BTU/HR S FR .. = "H
10437 PRINT"REYNOLDS NUM.... = "N2
10450 PRINT
10470 PRINT:PRINT:GOTO11150
10505 S1=.173*F4*E1*A1/A2
10508 Z1=F5*E2*((T7/100)↑4)
10510 S2=(1/F4)*(F4*((T1/100)↑4)-(1-A3)*F6*((T4/100)↑4))-Z1
10515 X1=(S1*S2/H)+T1
10520 P1=S1/H
10525 X2=1+.04*P1*((X1/100)↑3)
10530 X3=(T1+P1*((T1/100)↑4)+3*((X1/100)↑4))/X2
10535 X4=X1-X3+T1
10545 Q6=L1*(SQR(N5))/12
10550 Q7=.5*(EXP(Q6)+1/EXP(Q6))
10555 Q8=(T1-T3)/Q7
10560 X5=X4+Q8
10570 U9=X5
10575 GOSUB10742
10580 Y5=U6
10585 X6=X5+T1-Y5
10590 U9=X6
10595 GOSUB10742
10600 Y6=U6
10605 I1=1
10610 FORJ1=1TO10
10620 X7=(X5-X6)*(T1-Y6)/(Y5-Y6)+X6
10625 U9=X7
10630 GOSUB10742
10635 D7=U7
10640 D8=U8
10645 D9=V9
10650 Y7=U6
10652 X8=T1+D7
10655 S3=(Y7-T1)
10660 IFABS(S3)<.02THEN10700
10665 I1=I1+1
10670 X5=X6
10675 Y5=Y6
10680 X6=X7
10685 Y6=Y7
10690 NEXTJ1
10700 PRINT"GAS FLOW..... = "G1
10701 PRINT"INDICATED TEMP.. = "T1
10702 PRINT"GAS TEMP..... = "X8
10703 PRINT"DELTA T - RAD... = "D8
10704 PRINT"TOTAL DEL. T.... = "D7
10705 PRINT" ;H;N2;D9;D7
10706 PRINT"H BTU/HR S FR .. = "H
10707 PRINT"REYNOLDS NUM.... = "N2
10720 PRINT
10730 GOTO11150
10742 B6=(K2*(R1↑2))/(D1*12)
10744 B7=((N4*K1*12)/D1+.00692*F4*((U9/100)↑3)*E1)
10746 Z1=F5*E2*((T7/100)↑4)
10748 B8=.173*E1*(F6*(1-A3))*((T4/100)↑4)-F4*((U9/100)↑4)+Z1

```

```

10750 U5=U9+(B8/B7)
10752 N6=(L1*SQR(B7/B5))/12
10754 N7=.5*(EXP(N6)+1/EXP(N6))
10756 N8=(T3-U5)/N7
10758 U6=U5+N8
10760 U7=U9-U6
10762 U8=U9-U5
10764 V9=U5-U6
10766 RETURN
10780 IFT1<400THEN10786
10781 IFT1>4499THEN10786
10782 T2=INT(T1/100)
10783 T9=(T1/100)-T2
10784 C8=C9((T2-3),K9)+T9*(C9((T2-2),K9)-C9((T2-3),K9))
10785 GOTO10787
10786 PRINT"TIMUST BE BETWEEN 400 AND 4499 R"
10787 RETURN
10800 DATA .2395,.2397,.2405,.2417,.2435,.2458,.2485,.2512
10801 DATA .2542,.2574,.2607,.2638,.2670,.2700,.2727,.2752
10802 DATA .2278,.2800,.2823,.2846,.2868,.2892,.2915,.2938
10803 DATA .2962,.2984,.3010,.3034,.3062,.3090,.3120,.3153
10804 DATA .3192,.3237,.3287,.3342,.3414,.3480,.3588,.3698
10805 DATA .3828,.3977
10806 DATA .0356,.0418,.0478,.0536,.0591,.0643,.0692,.0738
10807 DATA .0781,.0820,.0861,.0898,.0934,.0968,.1002,.1036
10808 DATA .1072,.1100,.1130,.1158,.1186,.1214,.1242,.1270
10809 DATA .1295,.1325,.1348,.1373,.1398,.1422,.1445,.1470
10810 DATA .1425,.1520,.1542,.1568,.1592,.1616,.1640,.1665
10811 DATA .1590,.1713
10812 DATA .0118,.0143,.0168,.0191,.0213,.0237,.0258,.0280
10813 DATA .0303,.0325,.0347,.0368,.0387,.0407,.0425,.0446
10814 DATA .0464,.0481,.0497,.0515,.0532,.0545,.0560,.0573
10815 DATA .0587,.0601,.0615,.0628,.0642,.0655,.0668,.0682
10816 DATA .0694,.0707,.0720,.0732,.0745,.0758,.0772,.0784
10817 DATA .0798,.0811
11100 RETURN
11150 C1=VAL(AA$(64)):M1=VAL(AA$(68)):K1=VAL(AA$(72))
11151 REM RESET THESE SO THAT NEW VALUE WILL REFLECT INEXT INPUT.
11152 GOTO12400
11153 REM PRINT ROUTINE AT 12400
11154 GOTO10028
11232 .
12001 AA$(1)="D1 - OD OF TC WIRE           ":AA$(4)=".04":AA$(2)="INCHES":AA$(3)=" "
12004 AA$(5)="F1 - FLOW DIRECTION           ":AA$(8)=".1"
12005 AA$(6)=" (PERPENDICULAR = 1)"
12006 AA$(7)=" (PARALLEL FLOW = 0)"
12007 AA$(9)="F4 - TOTAL ANGLE FACTOR       ":AA$(12)=".85":AA$(10)=" "
12008 AA$(11)=" "
12010 AA$(13)="E1 - EMISSIVITY OF TC        ":AA$(16)=".3"
12011 AA$(14)=" ":AA$(15)=" "
12013 AA$(17)="A1 - RADIATION AREA          ":AA$(20)="1"
12014 AA$(18)=" ":AA$(19)=" "
12016 AA$(21)="A2 - CONVECTION AREA        ":AA$(24)="1"
12017 AA$(22)=" ":AA$(23)=" "
12019 AA$(25)="F2 - TYPE OF TEMP. INPUT    ":AA$(28)="0"
12020 AA$(26)=" (GAS TEMP GIVEN = 0)"
12021 AA$(27)=" (IND TEMP GIVEN = 1)"
12022 AA$(29)="K2 - THERM. COND. - WIRE     ":AA$(32)="14"
12023 AA$(30)=" (BTU/HR FT DEG. R )"
12024 AA$(31)=" "
12025 AA$(33)="R1 - RADIUS OF WIRE          ":AA$(36)=".020"
12026 AA$(34)="INCHES ":AA$(35)=" "
12028 AA$(37)="L1 - TC LENGTH TO SUPPORT    ":AA$(40)="0.70"
12029 AA$(38)="INCHES ":AA$(39)=" "
12031 AA$(41)="A3 - ABSORBTIVITY OF GAS     ":AA$(44)="0"
12032 AA$(42)=" ":AA$(43)=" "
12034 AA$(45)="F5 - FLAME ANGLE FACTOR      ":AA$(48)="0.05"
12035 AA$(46)=" (RADIATION ANGLE FACTOR )"
12036 AA$(47)=" "
12037 AA$(49)="E2 - FLAME EMISSIVITY        ":AA$(52)="1.0"
12038 AA$(50)=" ":AA$(51)=" "
12040 AA$(53)="T7 - FLAME RAD. TEMP        ":AA$(56)="3960"
12041 AA$(54)=" (DEGREES R )"
12042 AA$(55)=" "

```

```

12043 AA$(57)="F6 - WALL ANGLE FACTOR          ":AA$(60)=" .80"
12044 AA$(58)=" (RADIATION FROM WALL)"
12045 AA$(59)=" "
12046 AA$(61)="C1 - SPECIFIC HEAT             ":AA$(64)="0"
12047 AA$(62)=" (BTU/# DEG. R )
12048 AA$(63)=" "
12049 AA$(65)="M1 - VISCOSITY (#/FT HR)       ":AA$(68)="0"
12050 AA$(66)=" ":AA$(67)=" "
12052 AA$(69)="K1 - THERMAL COND.             ":AA$(72)="0"
12053 AA$(70)=" ":AA$(71)=" "
12055 AA$(73)="T1 - GIVEN TEMP.              ":AA$(76)="2760"
12056 AA$(74)=" (TEMP INPUT DEG R)"
12057 AA$(75)=" "
12058 AA$(77)="G1 - MASS FLOW                 ":AA$(80)="167"
12059 AA$(78)=" (#/SEC SQ FT )"
12060 AA$(79)=" "
12061 AA$(81)="T4 - WALL TEMP (DEG R)         ":AA$(84)="2100"
12062 AA$(82)=" ":AA$(83)=" "
12064 AA$(85)="T3 - SUPPORT TEMP             ":AA$(88)="2100"
12065 AA$(86)=" ":AA$(87)=" "
12067 AA$(89)="W - CONTINUATION CODE         ":AA$(92)="1"
12068 AA$(90)=" (NOT USED IN THIS PROGRAM VERSION)"
12069 AA$(91)=" "
12070 RETURN
12100 PRINTCHR$(147):PRINT:PRINT"*****USE £ TO ESCAPE EDIT ROUTINE*****"
12101 PRINT
12102 GOTO12300
12103 PRINT:PRINT:PRINT"TO USE DESCRIPTIVE EDIT ROUTINE PRESS RETURN"
12104 ZZ$="":INPUT"ENTER ID OF CHANGE";ZZ$
12105 IFZZ$="£"THEN10091
12106 IFZZ$="0"THEN12349
12107 IFZZ$=" "THENI=I
12108 PRINT:PRINT
12110 PRINTCHR$(147):PRINT:PRINT"*****USE £ TO ESCAPE EDIT ROUTINE*****"
12111 PRINT:PRINT
12112 FORI=IT089STEP4
12113 PRINT" AA$(I);AA$(I+3)
12114 PRINTAA$(I+1)
12115 PRINTAA$(I+2)
12116 ZZ$="0":INPUT "CHANGE TO ";ZZ$
12117 IFZZ$="£"THEN12130
12118 IFZZ$="0"THENAA$(QQ+3)=ZZ$
12119 PRINT:PRINT
12120 NEXT
12130 GOSUB12230
12140 GOTO10028
12230 D1=VAL(AA$(4))
12231 F1=VAL(AA$(8))
12232 F4=VAL(AA$(12))
12233 E1=VAL(AA$(16))
12234 A1=VAL(AA$(20))
12235 A2=VAL(AA$(24))
12236 F2=VAL(AA$(28))
12237 K2=VAL(AA$(32))
12238 R1=VAL(AA$(36))
12239 L1=VAL(AA$(40))
12240 A3=VAL(AA$(44))
12241 F5=VAL(AA$(48))
12242 E2=VAL(AA$(52))
12243 T7=VAL(AA$(56))
12244 F6=VAL(AA$(60))
12245 C1=VAL(AA$(64))
12246 M1=VAL(AA$(68))
12247 K1=VAL(AA$(72))
12248 T1=VAL(AA$(76))
12249 G1=VAL(AA$(80))
12250 T4=VAL(AA$(84))
12251 T3=VAL(AA$(88))
12252 W =VAL(AA$(92))
12260 RETURN
12300 PRINT" DATA SUMMARY"
12302 PRINT:PRINT"D1= "D1";PRINTTAB(10)"F1= "F1";PRINTTAB(20)"F4= "F4
12304 PRINT"E1= "E1
12306 PRINT:PRINT"A1= "A1";PRINTTAB(10)"A2= "A2";PRINTTAB(20)"F2= "F2
12308 PRINT"K2= "K2
12310 PRINT:PRINT"R1= "R1";PRINTTAB(10)"L1= "L1";PRINTTAB(20)"A3= "A3;

```

```
12311 PRINTTAB(30)"F5= "F5";PRINTTAB(70)"E2= "E2
12315 PRINT"T7= "T7
12318 PRINT:PRINT"F6= "F6
12320 PRINT"C1= "C1";PRINTTAB(10)"M1= "M1";PRINTTAB(20)"K1= "K1;
12321 PRINTTAB(30)"T1= "T1
12324 PRINT"G1= "G1";PRINTTAB(10)"T4= "T4";PRINTTAB(20)"T3= "T3;
12325 PRINTTAB(30)"W= "W
12326 GOTO12103
12349 IFZZ$=""THEN
12350 IFZZ$="D1"THENI=1
12351 IFZZ$="F1"THENI=5
12352 IFZZ$="F4"THENI=9
12353 IFZZ$="E1"THENI=13
12354 IFZZ$="A1"THENI=17
12355 IFZZ$="A2"THENI=21
12356 IFZZ$="F2"THENI=25
12357 IFZZ$="K2"THENI=29
12358 IFZZ$="R1"THENI=33
12359 IFZZ$="L1"THENI=37
12360 IFZZ$="A3"THENI=41
12361 IFZZ$="F5"THENI=45
12362 IFZZ$="E2"THENI=49
12363 IFZZ$="T7"THENI=53
12364 IFZZ$="F6"THENI=57
12365 IFZZ$="C1"THENI=61
12366 IFZZ$="M1"THENI=65
12367 IFZZ$="K1"THENI=69
12368 IFZZ$="T1"THENI=73
12369 IFZZ$="G1"THENI=77
12370 IFZZ$="T4"THENI=81
12371 IFZZ$="T3"THENI=85
12372 IFZZ$="W"THENI=89
12373 IFZZ$="E"THENI=12100
12379 PRINT:PRINT
12380 PRINTAA$(I),AA$(I+3)
12382 PRINTAA$(I+1):PRINTAA$(I+2)
12383 QQ$="":INPUT"ENTER NEW VALUE ";QQ$
12384 IFQQ$>""THENAA$(I+3)=QQ$
12385 GOSUB12230
12390 GOTO12100
12400 OPEN4,4,0:CMD4
12402 PRINT"DATA OUT - PROGRAM ** PM-TEMP4A ** VERSION DATED 11/07/85      RUN:"
```

APPENDIX E - SENSOR STRUCTURAL AND OPTICAL ANALYSIS:  
CYLINDRICAL VERSUS CONICAL

STRUCTURAL INTEGRITY OF THE SAPPHIRE CRYSTAL THERMOMETER

A first-order analysis was made of the sensor in the typical gas turbine combustor exit environment. The sensing element must withstand gas pressure loading of the flowing hot gas stream, engine vibration, and occasional particle impact. For this first-order analysis, however, only the gas pressure loading will be considered. The best representation of the sensing element would be a cylinder in crossflow. A uniform velocity is assumed along the immersed length of the cylinder. A local Mach Number of 0.2 and a total pressure of 400 psi were taken as a worst-case steady load. The maximum steady-state stress was found by considering the sensor as a cantilever beam with uniform load. See references 18 and 19.

Maximum Shear Stress,  $\tau$  max:

$$\tau \text{ max} = \frac{4}{3} \frac{V}{A}$$

where A is the cross sectional area

V is the shear force

for a uniformly loaded beam,

$$V = ql$$

where q is the load per unit length

l is the length

but  $q = CD \times d \times (P_t - P_s) \times (\text{unit length})$

CD is the drag coefficient

d is the diameter

$P_t$  is the total pressure

$P_s$  is the static pressure

For a Mach Number of 0.2,  $(P_t - P_s) = 1.029$

and  $(P_t - P_s) = 0.029 (400)$

$q = 1.16 \times d \times (0.029 \times 400) \times (\text{unit length})$



For this loading, the maximum shear stress:

$$\tau_{\max} = 4/3 V/A$$

$$\tau_{\max} = 22.85 \text{ 1/d (psi)}$$

The maximum tensile and compressive stresses are found from a circular beam equation:

$$(\sigma_x)_{\max} = \frac{32 M_{\max}}{\pi d^3}$$

and where  $M_{\max}$ , bending moment =  $\frac{q l^2}{2}$

$$(\sigma_x)_{\max} = 68.55 \frac{l^2}{d^2} \text{ (psi)}$$

Thus, both shear and tensile stress are dependent on the length-to-diameter ratio. Example 1/d values were chosen and stresses were calculated. This is shown in Table E-1.

Table E-1. Stresses in a Cylindrical Sensing Element Due to Gas Flow Loading.

<u>Sensor</u>	<u>Shear Stress</u>	<u>Tensile Stress</u>
1/d	psi	psi
5	114	1,714
9	206	5,553
17	388	19,811

#### PHYSICAL PROPERTIES OF SAPPHIRE PRODUCTS

Information channels were established with two sapphire products vendors, one university professor of materials science, and two GE materials engineers concerning the tensile strength and the modulus of rupture of single crystal aluminum oxide over the range of temperature from 0 to 1700° C.

What has been learned at this point is that sapphire exhibits a rupture strength that is dependent on both temperature and crystal orientation. In addition, sapphire exhibits a property of "slip" in various planes of the crystal structure. The slip results in deformation and is similar to "creep" in metal alloys. The stress required to cause slip ("flow stress") is dependent on both temperature and crystal orientation. At temperatures over about 800° C, the flow stress and orientation appear at this time to be controlling factors in sensor design.

Referring to Table E-1, the tensile stress is dominant for the useful range of sensor l/d (length to diameter ratio). The heat transfer studies showed that radiation loss is of greater importance than conduction loss for l/d of 4 or greater.

The physical properties of single crystal sapphire were further investigated, and it was learned from Professor Heuer's work at Case-Western Reserve University that slip along the basal plane at elevated temperatures would occur at a flow stress of approximately 700 to 800 psi at 1700° C. This orientation should be avoided. The prismatic slip plane is the second weakest plane, and would require approximately 14,000 psi to cause slip at 1700° C. This is encouraging.

#### Cylindrical Element Stress Problems

The length-to-diameter ratio for the sensor was considered. From the standpoint of keeping conduction loss errors small, a l/d of 4 or greater is sufficient, as was mentioned in last month's narrative. However, there is a real need to achieve an immersion distance sufficient to bring the sensor out of the boundary layer and into the "pitch line" region where a profile temperature peak is predicted. However, this is expected to increase the bending stress.

As an example, for an immersion of 1 inch and a cylindrical sensor diameter of 0.040 inch, a l/d of 25 would be needed (see Figure E-1). At the Mach 0.2 and 400 psia flow condition, the tensile stress at the base of the cylinder would reach 42,840 psi. This is considered too high for long life of the sensor.

#### Cylindrical Element Light Pipe Problems

It is still considered essential to maintain the light pipe properties of the cylindrical sensing element. The combustor discharge region is still expected to create solid deposits on a sensing element, just as on turbine parts. To prevent these deposits from causing attenuation of the internally reflected rays, an optical coating was proposed. This coating would maintain light pipe properties and prevent loss of calibration.

Two major optical coatings manufacturers were contacted. One company has tested coatings to 900° C, but recommends a 600° C limit for good life.

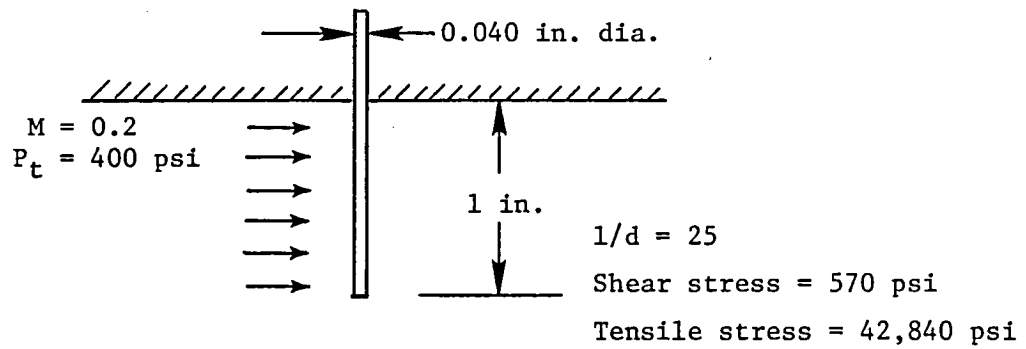

Figure E-1. Cylindrical Sensor.

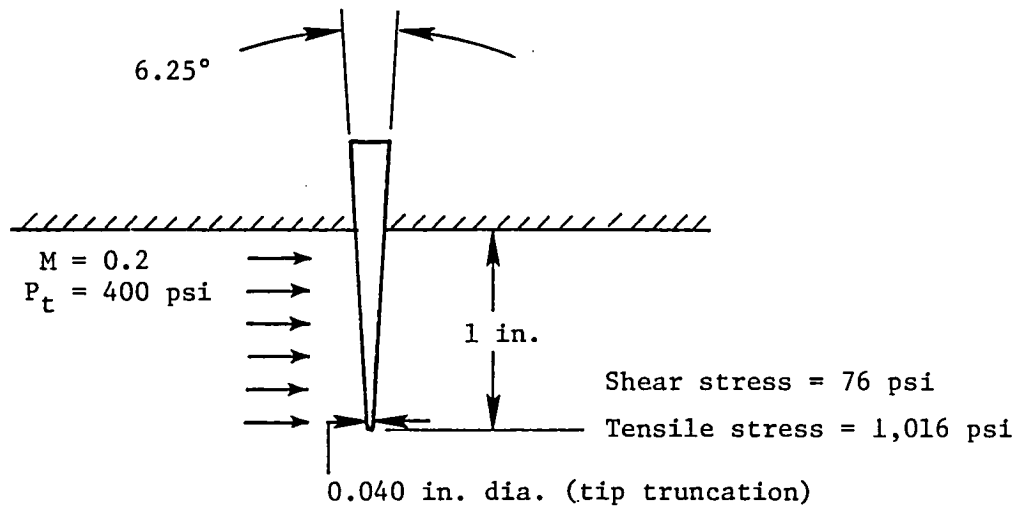

Figure E-2. Conical Sensor.

The second company did not expect any of its products to be applicable and suggested we contact a fiber optics manufacturer.

#### Cone-Shaped Element as Solution to the Problem

The idea occurred that a cone-shaped sensing element could solve two problems at once. A solid cone of 6.25 degrees included angle, with a tip truncated to 0.040 inch diameter, was selected for analysis purposes. The cone was presumed to be immersed 1 inch and held at the base (see Figure E-2). The beam analysis was used to calculate the maximum tensile stress using the same gas loading conditions as were used for the cylindrical sensor.

A tensile stress of only 1,016 psi was calculated. The beam analysis was checked by a different approach and appears to be correct. A shear stress of 76 psi was also calculated. This solves the first problem - stress.

The second problem to be solved is that of maintaining light transmission from the emitting cavity at the sensor tip to the detector, even in the presence of solid deposits. The cone shaped sensing element solves this problem by alleviating the need to depend on the light pipe mode for light transmission. This is because the cone has enough of a solid angle to permit an imaging device to be used; that is, a lens. Figure E-3 shows how this could be accomplished. The lens, aperture, and spacing are such that only rays that emit from the tip and do not intersect the cone surface cannot reach the fiber optic cable face. Thus, foreign matter deposits will have no effect on the calibration.

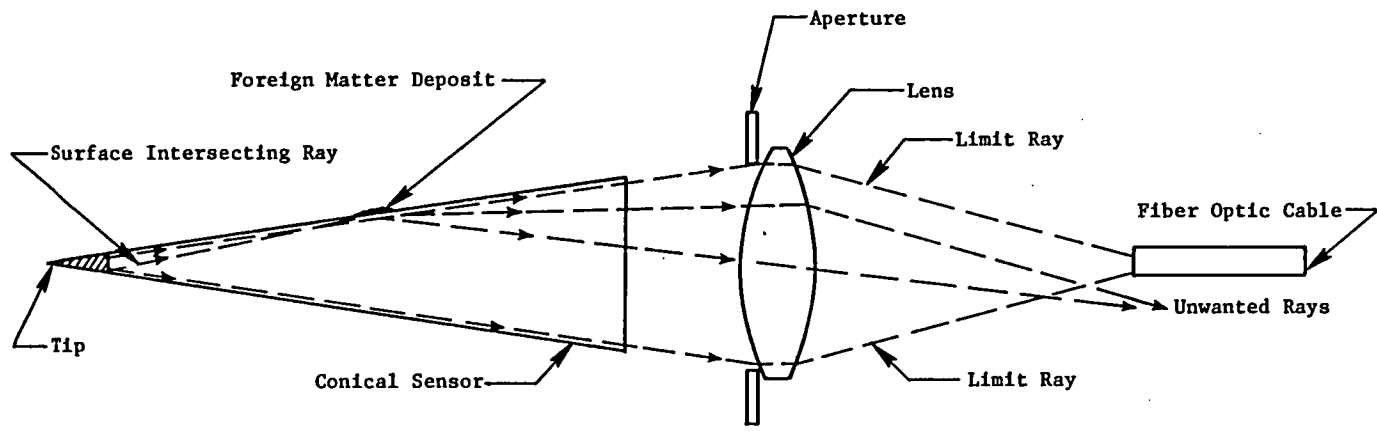

Figure E-3. Conical Sensor Operation.

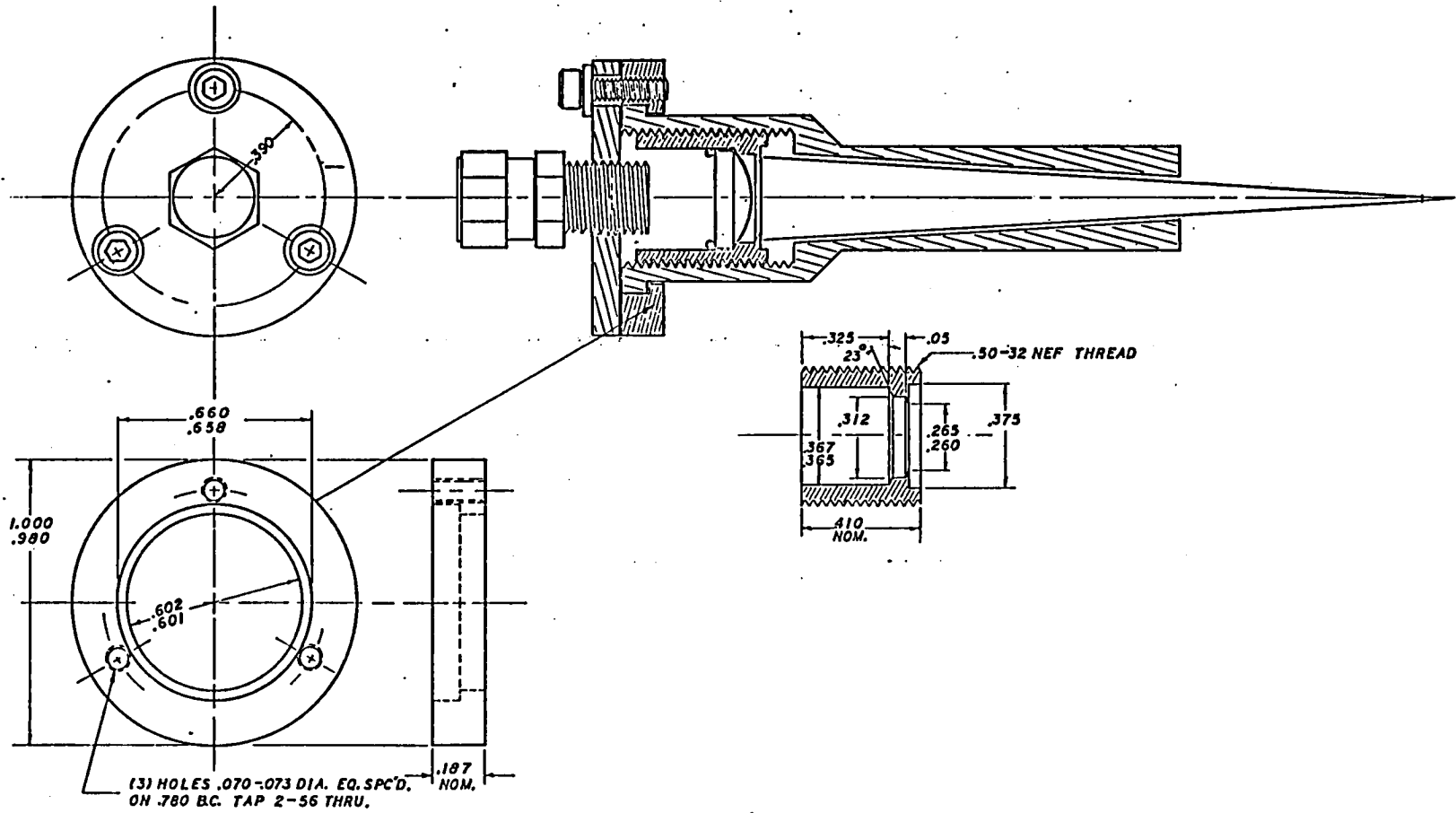

Figure F-1. Optical Gas Temperature Sensor and Holder Assembly.

APPENDIX G - ELECTRONIC DIAGRAMS, COMPONENT,  
AND PANEL LAYOUT

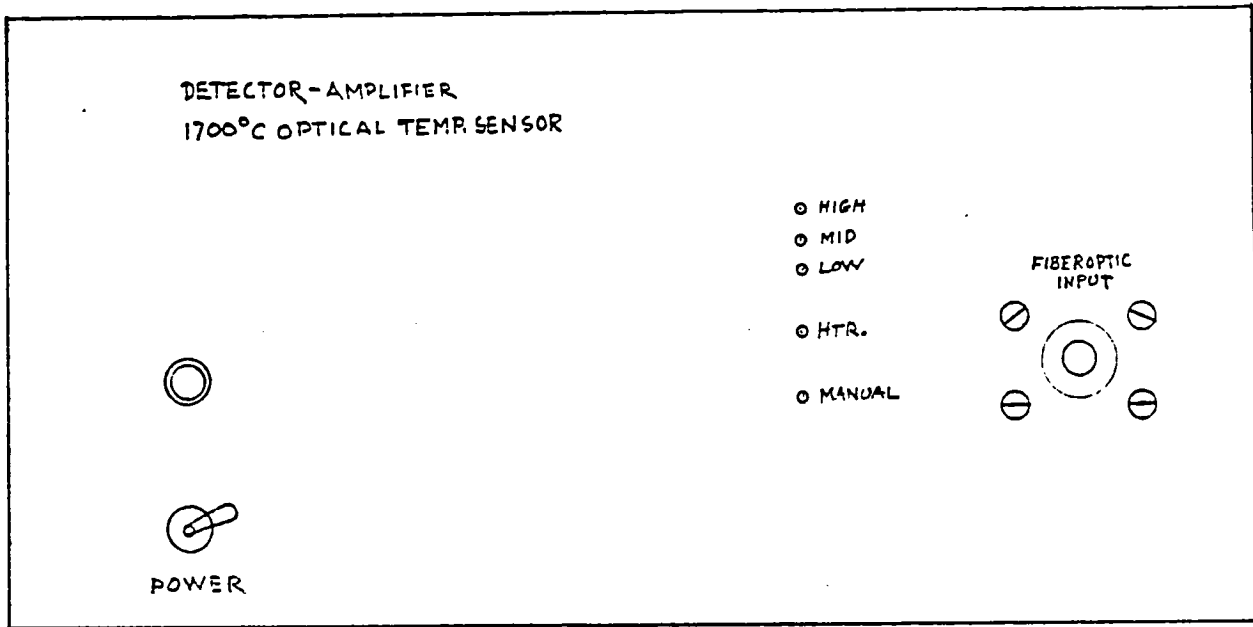

Figure G-1. Front Panel Layout.

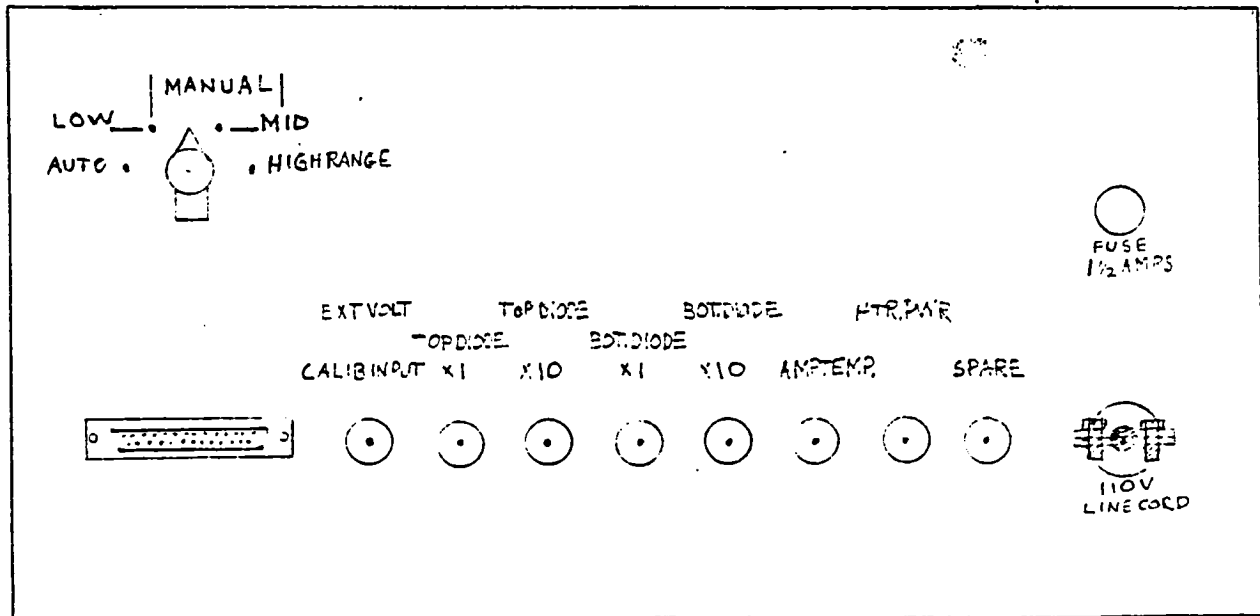

Figure G-2. Rear Panel Layout.



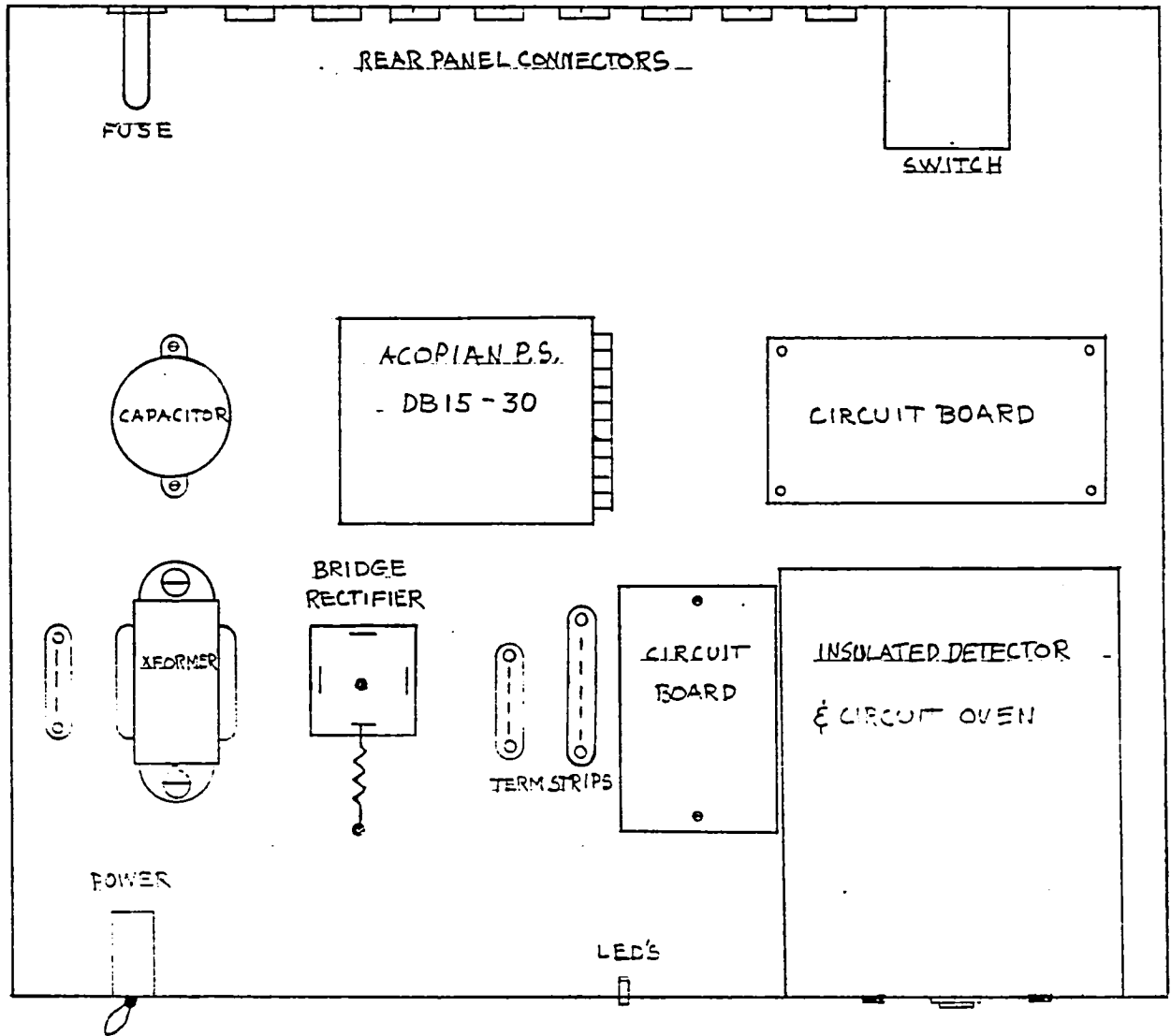
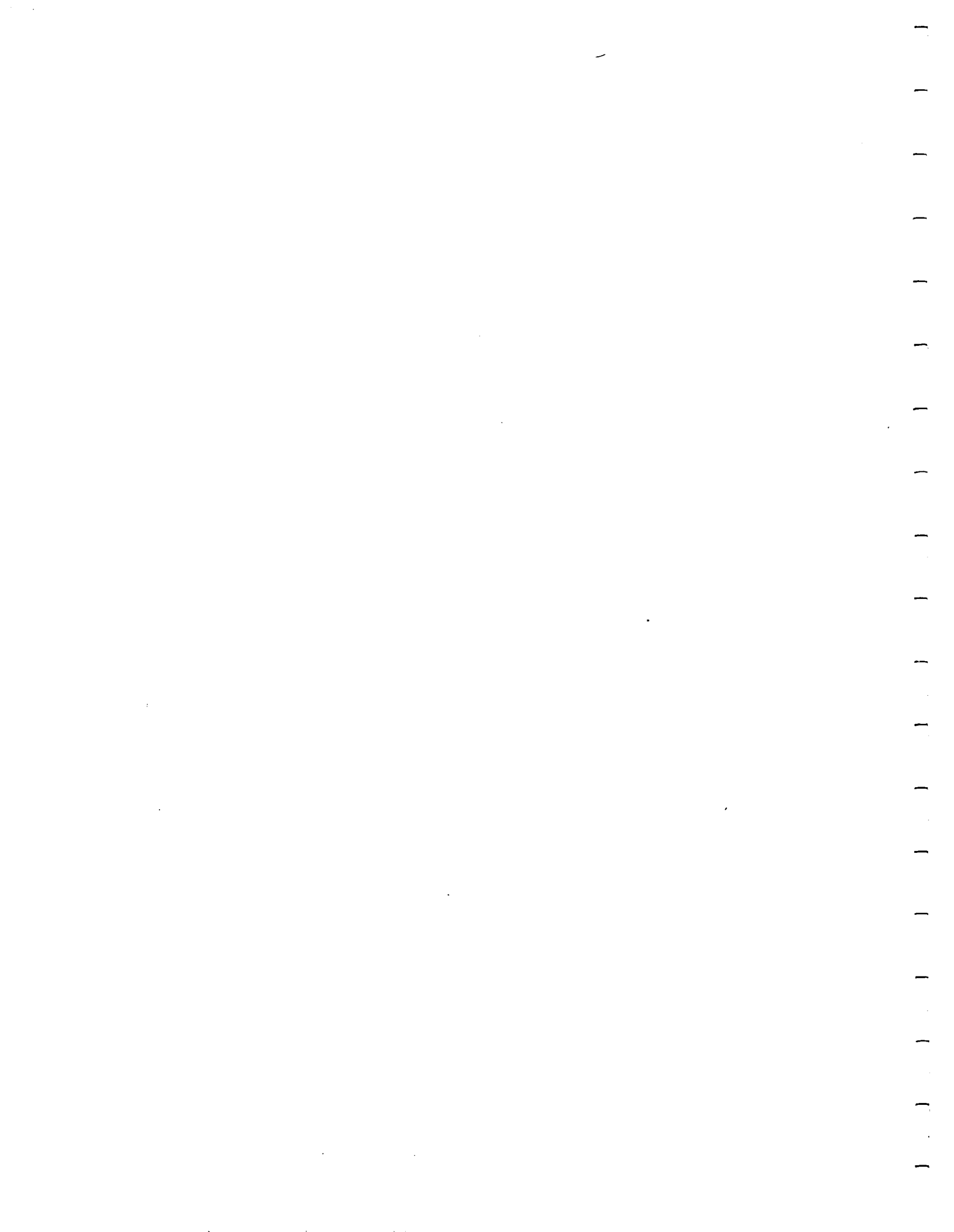
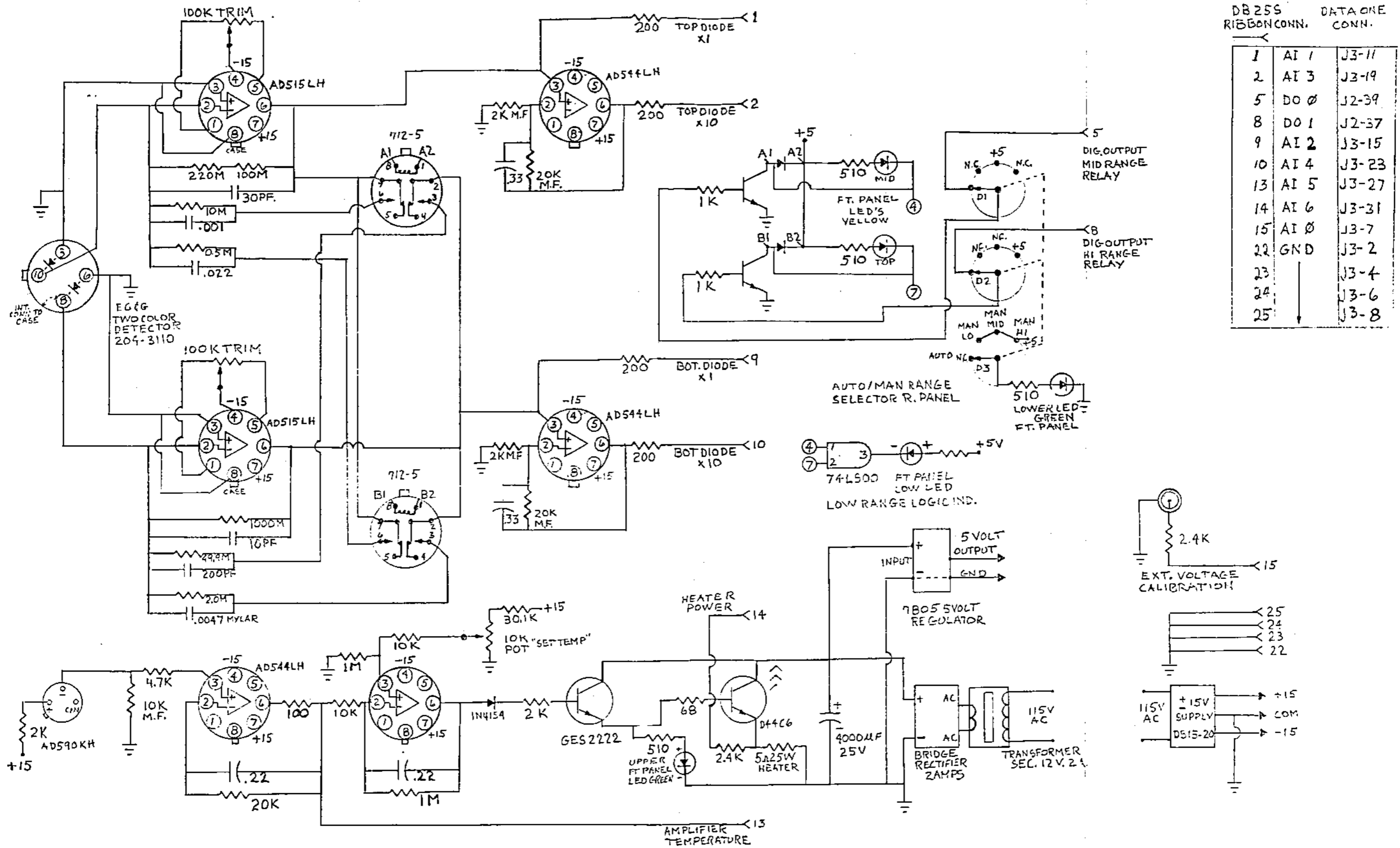

Figure G-3. Component Layout.





DB25S RIBBON CONN. DATA ONE CONN.

1	AI 1	J3-11
2	AI 3	J3-19
5	DO 0	J2-39
8	DO 1	J2-37
9	AI 2	J3-15
10	AI 4	J3-23
13	AI 5	J3-27
14	AI 6	J3-31
15	AI 0	J3-7
22	GND	J3-2
23		J3-4
24		J3-6
25		J3-8

Figure G-4. Schematic Diagram of 1700° C Gas Temperature Sensor.

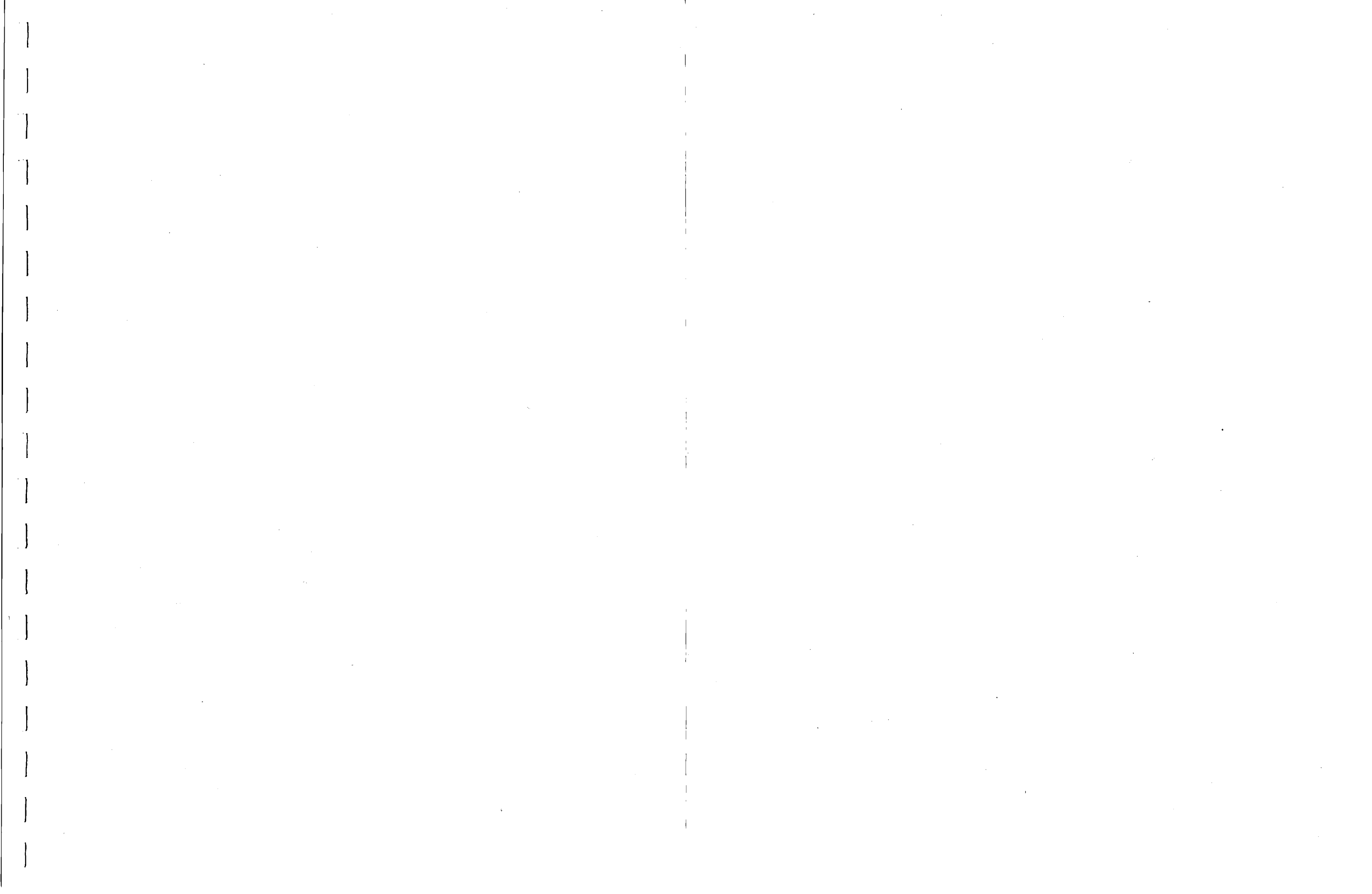

## APPENDIX H - PHOTOCURRENT CALCULATIONS

Calculations were made of photocurrent versus temperature for each of the elements of the two-color detector. The spectral sensitivity characteristics of the detectors were taken from the spec sheets furnished by the vendor, EG&G. Planck's law was used in a computer program that divides the silicon devices' spectrum into 43 wavelength intervals from 0.300 to 1.14 micrometers. The detected energy in each of the 0.02 micrometer bands was summed to form the total response. Losses for each of the optic elements in the sensor system were estimated and taken into account. Table H-1, attached, is a condensed tabulation of the results. Column 1 is the temperature in degrees C. Column 2 is the photocurrent for the bottom diode element. The third column is the photocurrent for the top diode element. And the fourth column lists the ratio of top diode element to bottom diode element photocurrents.

Table H-1. Photocurrent and Ratio Versus Temperature.

<u>Temperature Degrees C</u>	<u>Photocurrent, Top Diode Element Amps</u>	<u>Photocurrent, Bot. Diode Element Amps</u>	<u>Current Ratio I-Top/I-Bottom</u>
500	1.6609E-10	6.0021E-11	2.767
700	8.1257E-09	2.2862E-09	3.554
900	1.1207E-07	2.5405E-08	4.411
1100	7.4998E-07	1.4063E-07	5.333
1300	3.1908E-06	5.0515E-07	6.317
1500	1.0026E-05	1.2621E-06	7.360
1700	2.5454E-05	3.0077E-06	8.463
1900	5.5296E-05	5.7463E-06	9.622

## APPENDIX I - OPERATING INSTRUCTIONS

1. Assemble probe and fiber optic cable. See Figure 12, "Optical Gas Temperature Sensor and Holder Assembly" and Appendix F, "Mechanical Detail of Sensor Assembly."
2. Assemble electronics system. See Figure 14, "1700° C Gas Temperature System - Electronics Block Diagram."
3. Apply line power: 115 volts alternating current, 60 hertz to the fully connected system. Give the thermostated detector module about 15 minutes for temperature stabilization before taking readings.
4. To take data, load the program labeled "A/D READ-M10" and run it. When run, the program will request a calibration file. Select the file corresponding to the probe and fiber optic cable being used.
5. Shield the probe from stray energy and from elevated temperature and take a "zero-reading set" according to the program menu.
6. Take sensor temperature data by selecting from the menu. The sensor temperature data is displayed on the screen; the data can be printed if the print feature is selected.
7. The gas temperature can be calculated from the sensor temperature if the convection and radiation heat transfer environment is entered. Load program PM-TEMP4A and enter the data from the keyboard as requested.

## APPENDIX J - SCANNING ELECTRON MICROGRAPHS

A set of scanning electron micrographs are presented for Cone Elements 1 and 3, taken after the oven and propane-air flames testing given in Table 11, Test Summary Chart. Figures J-1 and J-2 are similar views of the Cone Element 1 tip. The solid sapphire cone apparently had a very small tip fracture during manufacture of about 80 to 85 microns diameter. This small truncation was coated, as was the forward third of the cone. The sputtered 70% platinum and 30% rhodium coating conformed to the striated fracture surface as well as the fine-ground cone side. The thickness was estimated by the vendor at the time of the coating to be 2000 Angstroms.

This was followed by an aluminum oxide topcoat of 1.5 microns (estimated by vendor). Figures J-1 and J-2 show excellent adherence with little or no chipping or spalling of the coatings.

Cone Element 3 is shown in Figures J-3, J-4, J-5, and J-6. This cone element had a 3500 Angstrom coating of 94% platinum and 6% rhodium with no overcoat. These figures, just as the previous figures, were taken after high temperature exposure. However, as shown on Table 11, a peak temperature of 1750° C was reached, and 107 cycles from room temperature to 1700° C were also run. Figures J-3 and J-4 each show some debris attached. This is believed to be dust that was statically attracted between test time and SEM time. The photos show good adhesion of the metallic coating. Figures J-5 and J-6 were taken at the temperature transition region about one-half inch from the tip. Figure J-5 shows a darkened appearance at the top of the figure where the temperature did not reach as high a value as the lower half of the figure. The peak temperature at the transition region was at least 100° C cooler than the tip. Comparing Figures J-4 and J-6 leads one to conclude that the coating was flame polished near its melting point at the tip. Figure J-4 shows a much smoother surface texture than Figure J-6.

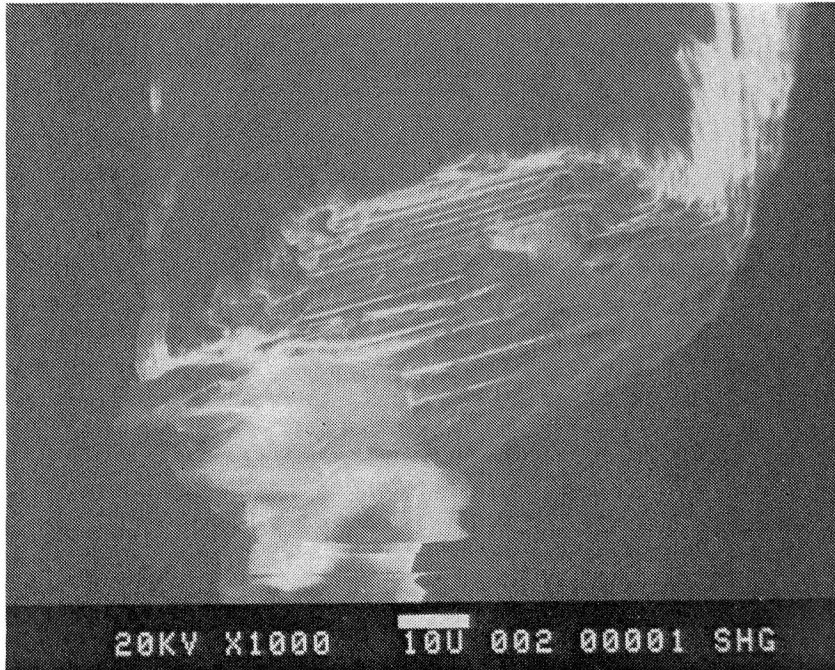

Figure J-1. Cone Element of No. 1 Tip.

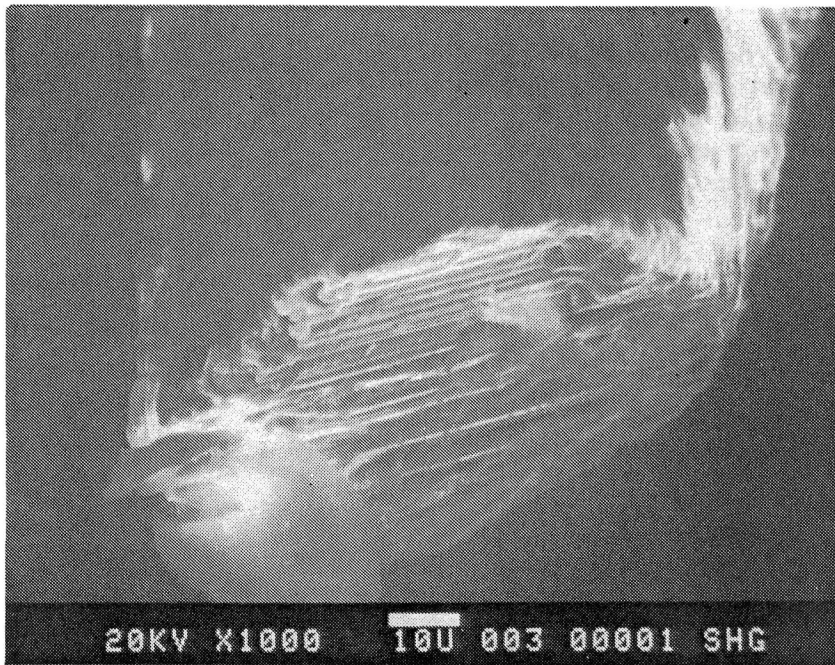

Figure J-2. Cone Element of No. 2 Tip.



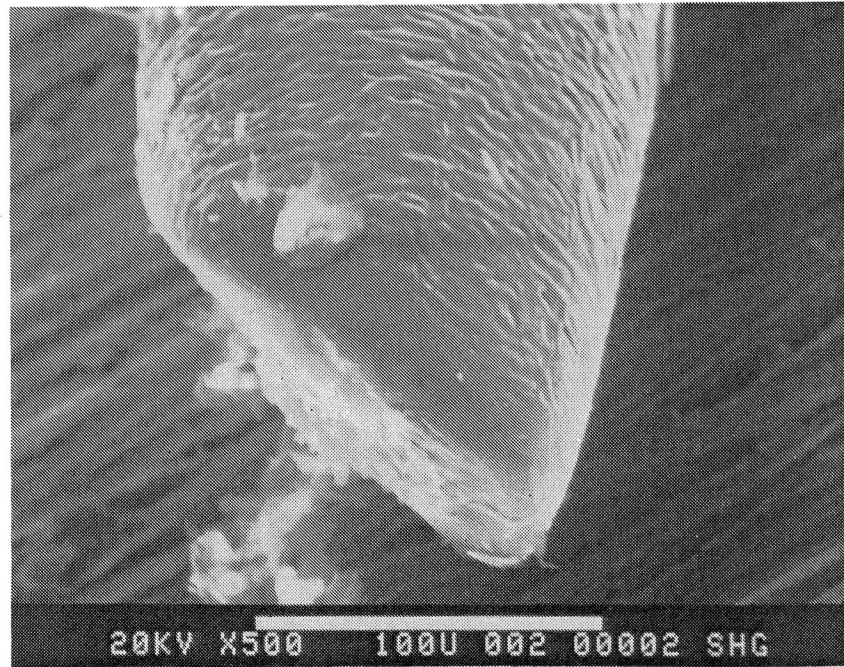

Figure J-3. Cone Element of No. 3 Tip.

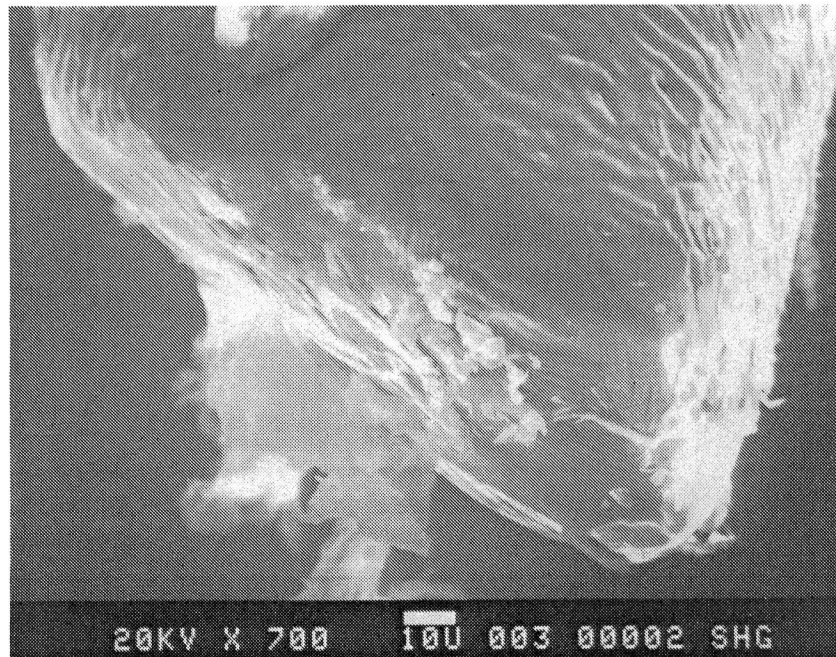

Figure J-4. Cone Element of No. 3 Tip.

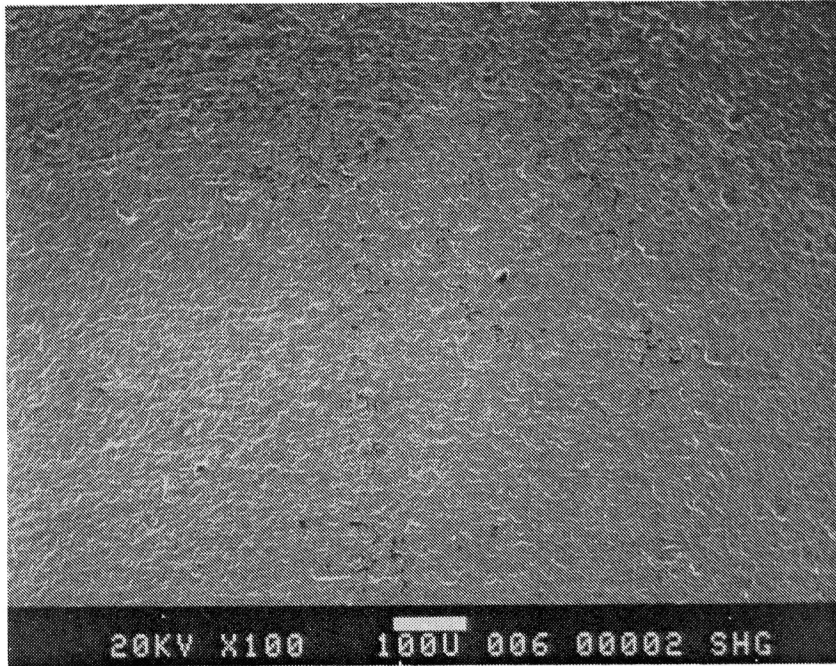

Figure J-5. Cone Element of No. 3 Side.

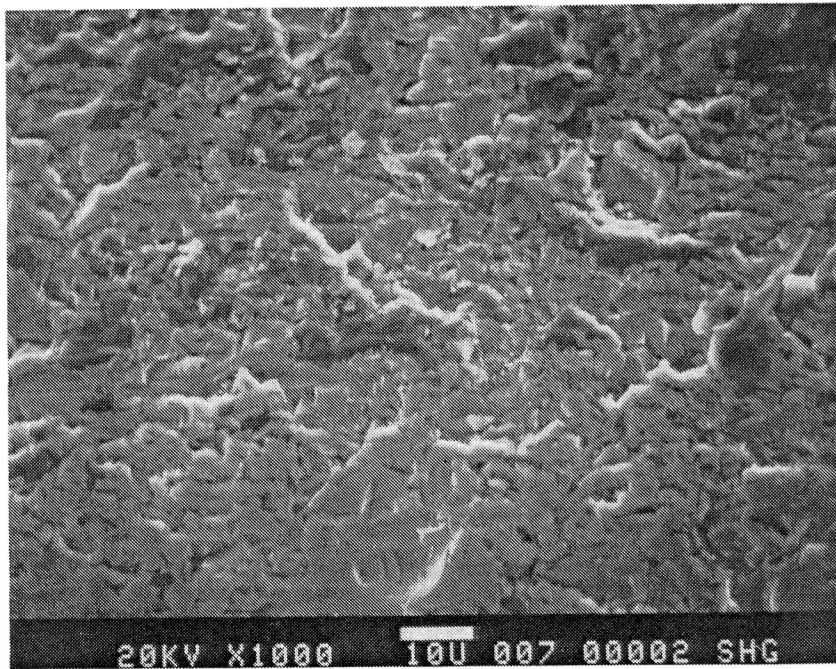

Figure J-6. Cone Element of No. 3 Side.

1000

1



LANGLEY RESEARCH CENTER  
  
3 1176 01315 3276

