

## N O T I C E

THIS DOCUMENT HAS BEEN REPRODUCED FROM  
MICROFICHE. ALTHOUGH IT IS RECOGNIZED THAT  
CERTAIN PORTIONS ARE ILLEGIBLE, IT IS BEING RELEASED  
IN THE INTEREST OF MAKING AVAILABLE AS MUCH  
INFORMATION AS POSSIBLE

10 pages

NASA TECHNICAL MEMORANDUM

NASA TM-88466

IN-18373

ELECTROLYSIS CELL FOR THE MANUFACTURE OF PERSULFATES

J. M. Cueto

Translation of "Elektrolyse-Zelle für die Gewinnung von Persulfaten", West German patent application No. 19 08 872, date of publication June 18, 1970, pp. 1-7

(NASA-TM-88466) ELECTROLYSIS CELL FOR THE  
MANUFACTURE OF PERSULFATES (National  
Aeronautics and Space Administration) 10 p  
CSCL 07D

N86-29008

Unclas  
G3/25 43467

NATIONAL AERONAUTICS AND SPACE ADMINISTRATION  
WASHINGTON, D.C. 20546 JULY 1986

## STANDARD TITLE PAGE

1. Report No. NASA TM-88466	2. Government Accession No.	3. Recipient's Catalog No.	
4. Title and Subtitle ELECTROLYSIS CELL FOR THE MANUFACTURE OF PERSULFATES		5. Report Date JULY 1986	
		6. Performing Organization Code	
7. Author(s) J. M. Cueto		8. Performing Organization Report No.	
		10. Work Unit No.	
9. Performing Organization Name and Address SCITRAN Box 5456 Santa Barbara, CA 93108		11. Contract or Grant No. NASW- 4004	
		13. Type of Report and Period Covered Translation	
12. Sponsoring Agency Name and Address National Aeronautics and Space Administration Washington, D.C. 20546		14. Sponsoring Agency Code	
		15. Supplementary Notes  Translation of "Elektrolyse-Zelle für die Gewinnung von Persulfaten", West German patent application No. 19 08 872, date of publication June 18, 1970, pp. 1-7	
16. Abstract  Cell for the electrolytic generation of persulfates, characterized by the fact that a housing acts as cathode, is made of metal, and consists of a lower electrolytically active section and an upper electrolytically inactive section. Designed so that there is produced the greatest possible current density suited to produce the desired electrolysis effect.			
17. Key Words (Selected by Author(s))		18. Distribution Statement  Unclassified and Unlimited	
19. Security Classif. (of this report) Unclassified	20. Security Classif. (of this page) Unclassified	21. No. of Pages 8	22. Price

FEDERAL REPUBLIC OF GERMANY  
GERMAN PATENT OFFICE

Patent Disclosure 1908872

document code: P 19 08 872.3  
announcement date: Feb. 21, 1969  
disclosure date: June 18, 1970

issuance priority: -

union priority:

date: April 19, 1968

country: Spain

document code: 352889

name: electrolysis cell for manufacture of persulfates

addition to: -

elimination from: -

announcer: Productos Electroliticos S.A. Barcelona (Spain)

representative: von Schumann, Dipl.-Ing. Heinz, patent attorney,  
8000 Munich

named as inventor: Cueto, José Maluquer, Barcelona (Spain)

Patent search request as per par. 28a PatG has been made  
Brochures to be considered when assessing the patentability

OE-PS 179 773

US-PS 2 281 090

FR-PS 831 012

DK-PS 56 829

GB-PS 506 213

SW-PS 96 372

Productos Electroliticos, S.A., Barcelona, Spain

## Electrolysis Cell for the Manufacture of Persulfates

It is known that the electrolytic production of persulfates with good yield requires, in addition to an increased anodic current density, operation at a low temperature with increased current concentration; furthermore the persulfate formed must be removed from the reducing effect of the hydrogen generated at the cathode.

In the electrolytic production of persulfates conventional up to now one tries to avoid an excessive heating of the electrolyte by the placement of cooling coils in the cell trough; or one circulates the electrolyte in order to then cool it external to the cell. The first solution is disadvantageous insofar as a cell and thus a bath of somewhat large size is required for this with resultant reduction in the current concentration; or it is necessary, however, to keep the electrodes apart from one another so that the voltage drop increases and thus the heating. The disadvantage of the second solution is that in this way a heating of the electrolyte is not avoided, but that the already heated electrolyte is merely cooled.

Furthermore the state of the technology requires the separation of the anode and the cathode by means of a diaphragm in order to prevent reducing effects by hydrogen. This diaphragm produces a voltage drop which reduces the required current concentration and which causes heating up.

The function of the invention is to avoid these disadvantages. This is achieved as per invention with a cell for the electrolytic production of persulfates in which a metal housing, preferably made of hardened lead or corrosion-resistant steel, is provided to act as cathode. This housing consists of a lower electrolytically active section and an upper electrolytically inactive section, both of which join up with each other and together hold the circulating electrolyte which is kept at a constant level by at least

one outlet in the upper part, whereby the upper housing section provides a free surface as large as possible for the quick removal of the hydrogen generated at the cathode and which exhibits a spacing between the longitudinal partitions which is considerably greater than their height; furthermore two insulating supports are inserted into which each end of a conducting rod is placed, from which a grid, preferably made of platinum, is suspended to act as anode, and whereby the lower housing section shows a spacing between the active longitudinal partitions as small as possible, which is also considerably smaller than their height so that between each of the active partitions of the lower housing section and the between-hanging grid the highest possible current concentration is produced for the desired electrolysis effect. Thus the electrolysis cell as per invention has a lower, active section which is higher than it is wide while the connecting inactive upper section is wider than it is high.

In the following an implementation version of the invention is described as an example with the aid of the attached drawing

009825/1724

Here we see

Figure 1 as the plan view of an electrolysis cell as per the invention;

Figure 2 represents the view of the longitudinal section along the line II-II in figure 1; and

Figure 3 represents the cross sectional view along the line III-III in figure 2.

The electrolysis cell as per the invention has a housing 1 which consists preferably of hardened lead, non-oxidizing steel or another alloy. The housing 1 is equipped with a lower section 2, which essentially is active electrolytically.

Connected thereto is an upper section 3, which essentially is inactive electrolytically.

The housing 1 active as cathode has thick walls in order to prevent deformations. In addition lines 4,5 are connected to the housing 1 to serve as inlet and outlet for the electrolyte. As can be seen especially clearly from figure 3, the active partitions 2a and 2b of the lower section 2 are placed at a distance  $d$  from each other which is smaller than the height  $h$  of these partitions 2a, 2b, in order to especially achieve the above mentioned effects.

On the other hand figures 1 to 3 show that the upper section 3 has a spacing  $D$  between its longitudinal partitions 3a and 3b, which is greater than their height  $H$ . Thus one obtains a flat and wide, pan-shaped version for the above named purpose.

In the two front faces of the upper section 3 one finds two cross-lying insulators 6 which

009825/1724

carry the platinum grid 7 acting as anode, and namely by means of a conducting rod 8, which with its ends rests in corresponding longitudinal grooves in the insulators 6 and which is joined to the grate 7, for example by welding or soldering.

The anode grid 7 lies in that vertical plane which contains the longitudinal axis of the housing 1, whereby the distance between the grid 7 and the lateral partitions of the housing section 2 is merely a few millimeters. Within the housing section 2 the anode grid 7 exhibits a far greater mesh density than in the upper housing section 3. The size of the cell depends on the work intensity which is itself determined by the characteristic values of the available current.

Compared to the devices used until now the cell as per invention exhibits considerable advantages whereby it is particularly suited for the production of potassium persulfate. As an example one must emphasize its reduced volume, whereby the electrolyte circulates with great speed, which is subjected before its entry into the housing 1 to a cooling, and which is again cooled during the exit from housing 1, so that it is only necessary to use the smallest amount of electrolyte possible. Furthermore one is operating with a relatively low voltage drop. A complete precipitation of the crystals formed in the electrolyte is achieved. In addition the contact of the circulating electrolyte with the hydrogen generated at the cathode is very brief so that the reduction reaction is limited to a minimum without the need for interfering diaphragms which cause voltage drops and accordingly heating.



## Claim

Cell for the electrolytic generation of persulfates, characterized by the fact that a housing (1) acting as cathode and made of metal, preferably hardened lead or corrosion-resistant steel, which consists of a lower electrolytically active section (2) and an upper electrolytically inactive section (3), both of which are joined to each other and together contain the circulating electrolyte, kept at a constant level by means of at least one discharge port (5) in the upper section (3), whereby the upper housing section (3) makes available for the quick removal of the hydrogen generated at the cathode a free surface as large as possible and exhibits a spacing (D) between the longitudinal partitions (3a and 3b), which is considerably greater than their height (H), into which furthermore two insulating supports (6) are inserted into which one end each of a conducting rod (8) is placed, from which a grid (7), preferably made of platinum, serving as anode is suspended, and whereby the lower housing section (2) exhibits a spacing (d) as small as possible between the active longitudinal partitions (2a and 2b), which is also considerably smaller than their height (h), so that between each of the active partitions (2a and 2b) of the lower housing section (2) and the between-hanging grid (7) there is produced the greatest possible current density suited to produce the desired electrolysis effect.

ORIGINAL  
OF P... ..

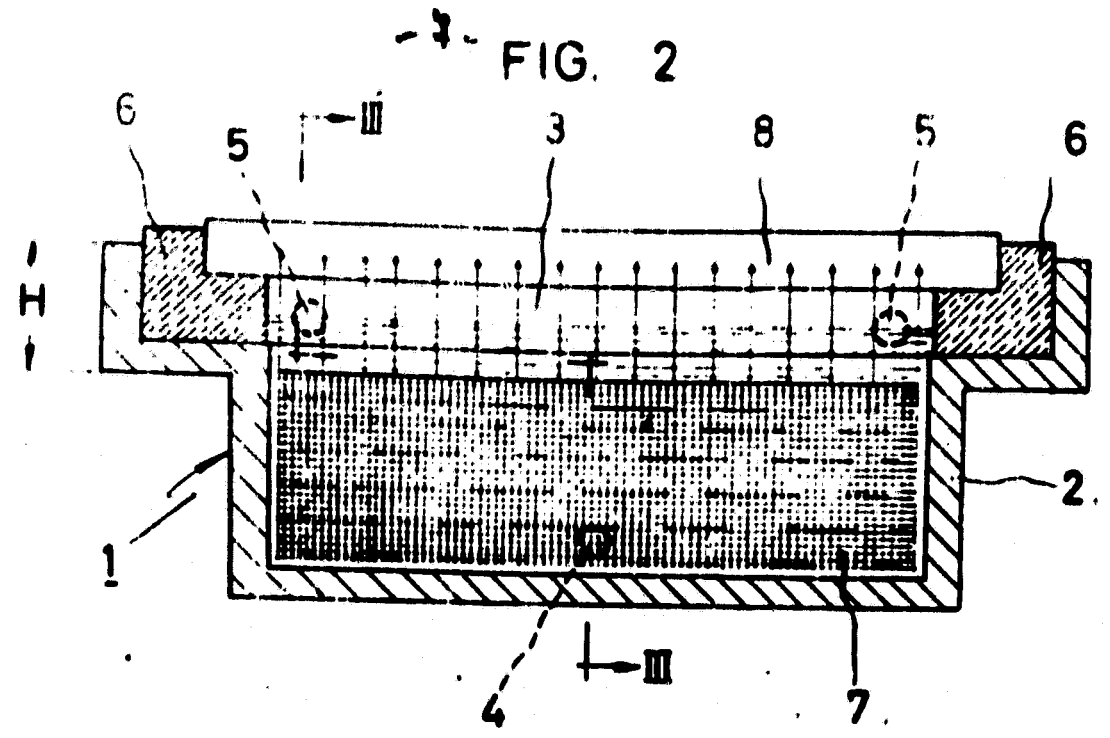
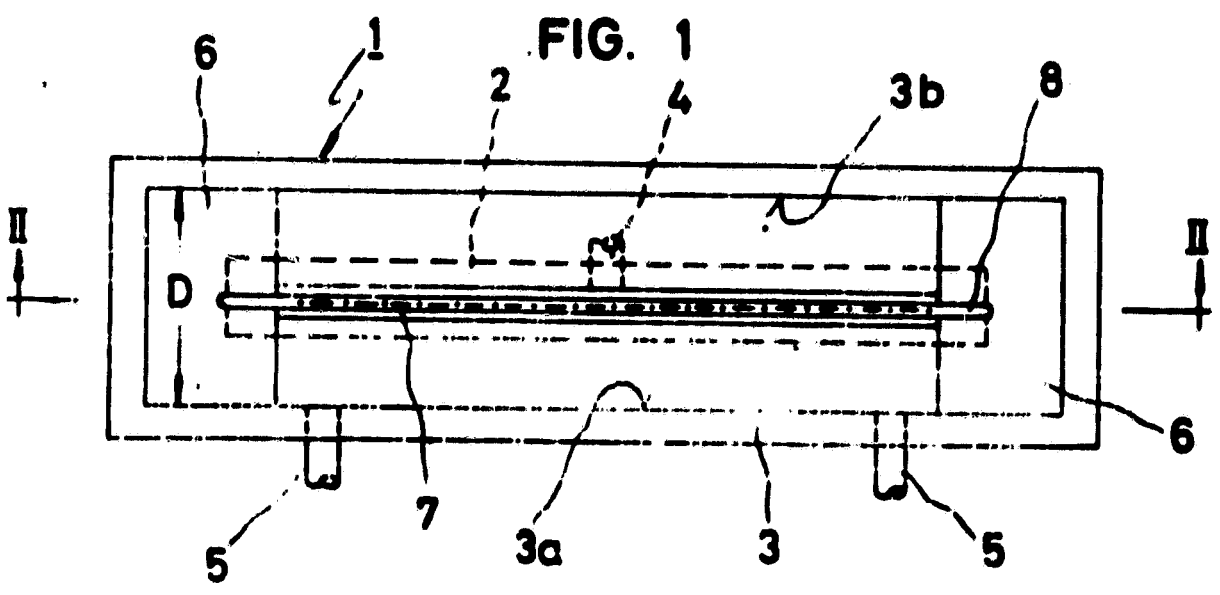

ORIGINAL DESIGN IS  
OF POOR QUALITY

