

# NASA Technical Memorandum 87766

NASA-TM-87766 19860022096

## FLIGHT TEST OF PASSIVE WING/STORE FLUTTER SUPPRESSION

F. W. CAZIER, JR.

M. W. KEHOE

AUGUST 1986

**LIBRARY COPY**

SEP 18 1986

LANGLEY RESEARCH CENTER  
LIBRARY, NASA  
HAMPTON, VIRGINIA

**NASA**

National Aeronautics and  
Space Administration

Langley Research Center  
Hampton, Virginia 23665



NF01639



## ABSTRACT

Flight tests were performed on an F-16 airplane carrying on each wing an AIM-9J wingtip missile, a GBU-8 bomb near midspan, and an external fuel tank. Baseline flights with the GBU-8 mounted on a standard pylon established that this configuration is characterized by antisymmetric limited amplitude flutter oscillation within the operational envelope. The airplane was then flown with the GBU-8 mounted on the decoupler pylon. The decoupler pylon is a NASA concept of passive wing-store flutter suppression achieved by providing a low store-eylon pitch frequency. The decoupler pylon successfully suppressed wing-store flutter throughout the flight envelope. A 37 percent increase in flutter velocity over the standard pylon was demonstrated. Maneuvers with load factors to 4g were performed. Although the static store displacements during maneuvers were not sufficiently large to be of concern, a store pitch alignment system was tested and performed successfully. One GBU-8 was ejected demonstrating that weapon separation from the decoupler pylon is normal.

## INTRODUCTION

To satisfy multimission requirements, modern fighter aircraft carry many types and combinations of external stores pylon-mounted from the wing. The carriage of these stores can lower the wing flutter speed to within the operational flight envelope of the aircraft, thus reducing the operational and mission capabilities of the airplane. Conventional passive means that have been used previously for raising the flutter speed include changing the stiffness of the wing or the store pylon, adding mass ballast, and relocating the stores. The decoupler pylon, the subject of this paper, is a new passive system which has been shown in exploratory studies to be effective in suppressing wing-store flutter instabilities. The decoupler pylon dynamically isolates (or "decouples") the wing from store pitch inertia effects by providing a low store pitch frequency. This could be accomplished, for example, by suspending the store from a pivot that allows the store to rotate in pitch but with the store pitch motion restrained by a soft spring and damper (ref 1). An alignment system can be incorporated to minimize static pitch deflections of the store due to maneuvers and aerodynamic loads. Analyses and wind-tunnel tests in the Langley Transonic Dynamics Tunnel of YF-17 and F-16 flutter models with stores mounted on early decoupler pylon designs have shown increases in velocities in excess of 40 percent over stores mounted on standard pylons without encountering flutter (ref. 2).

Based on the encouraging results of these analyses and tests, a program was initiated to design, build, and flight test a decoupler pylon (ref. 3). The configuration selected to be tested consisted of the following on each wing of an F-16 airplane: AIM-9J wingtip missile, a GBU-8 bomb near midspan, and a one-half full 370-gallon fuel tank inboard. This configuration exhibits well-defined, limited amplitude, antisymmetric flutter when the GBU-8 bomb is carried on a standard F-16 pylon. Analyses and wind-tunnel tests indicated that mounting the GBU-8 stores on decoupler pylons in place of the standard pylons would appreciably increase the flutter speed of this configuration. The present program was to demonstrate the practicality of the decoupler pylon as a flight-worthy flutter suppression system.

The objectives of the flight tests of the decoupler pylon were: (1) to demonstrate an improvement in flutter speed of at least 30 percent over the

N86-31568 #

standard pylon flutter boundary, (2) to assess the requirement for and the performance of the alignment system, and (3) to demonstrate that store separation from the decoupler pylon was normal. These objectives were to be accomplished by first flying baseline flights with the stores mounted on standard pylons. In these tests, the baseline flutter boundary was to be measured and the characteristics of the flutter oscillation were to be determined in straight and level and maneuvering flight, with excitation provided by natural atmospheric turbulence or the airplane control system. After these flights, the GBU-8 was to be mounted on the decoupler pylon and the flight test conditions repeated.

A pair of flight-worthy decoupler pylons was designed and fabricated by General Dynamics under contract to NASA. The results of a feasibility and conceptual design study are given in reference 4. The design, fabrication, and ground testing of the pair of flight decoupler pylons are documented in reference 5. The ground structural tests performed on these decoupler pylons revealed that the pylons were binding because of friction in the pylon pivots. These decoupler pylons were flown on two flights and then modified to reduce this friction. The flight tests were continued and completed with these modified decoupler pylons.

This report presents sample results from the baseline flights, the flights with the initial decoupler pylon, and the flights with the modified decoupler pylon. The results of preparatory work performed for the flight tests, including airplane ground vibration tests and pylon structural tests, are documented in reference 6-8. The flight tests were conducted as a joint effort by the Ames-Dryden Flight Research Facility and the Langley Research Center on an F-16 from the Joint Test Force at Edwards Air Force Base, California. NASA and Air Force pilots alternated on the test flights. General Dynamics Corporation provided technical assistance.

## TEST CONFIGURATION

### F-16 Airplane

Flight Configuration.- The F-16 with the flight test stores configuration is shown in flight over Edwards Air Force Base in Figure 1. On each wing are mounted an AIM-9J missile on a wingtip launcher rail, a GBU-8 store (2250 lbm. guided bomb) on a pylon near the wing midspan, and a 370 gallon fuel tank on a pylon at the inboard wing station. The fuel tank has three compartments. For the flutter flight tests, the forward and aft compartments were full of fuel and the center bay was empty. The test aircraft was the Full Scale Development F-16A which was instrumented for flutter and loads testing. This F-16 was equipped with an analog fly-by-wire control system.

Excitation System.- An on-board excitation system was installed to interface with the control system and to provide repeatable excitation for the flutter testing. A control panel was installed in the cockpit to allow the pilot to select and control the on-board excitation system. This system generated sinusoidal commands to the flaperon servo amplifiers for flaperon oscillation which were summed with the pilot stick commands. Using the control panel, the pilot could command and regulate: (1) system start and stop, (2) symmetric or antisymmetric excitation, (3) frequency sweep or a constant frequency dwell (herein called a "burst"), (4) excitation frequency,

(5) excitation amplitude, (6) and frequency sweep rate or burst duration. The excitation amplitude could be varied from zero to  $\pm$  one degree of flaperon movement. Sweep and burst frequencies ranged from 2 Hz to 20 Hz.

Instrumentation.- The location and types of instrumentation on the airplane are shown in Figure 2. The flutter instrumentation consisted of accelerometers on the fuel tanks, GBU-8, wingtip launchers, horizontal tail and vertical tail. In addition, position indicators were located on the control surfaces. Aircraft airspeed, altitude, angle-of-attack and sideslip were measured from nose boom sensors (see Figure 1). Aircraft accelerations, rates, attitudes, fuel quantities, and control forces also were measured. For the store separation test, high-speed motion picture cameras were installed in the fuselage and in a special wingtip missile.

### Decoupler Pylon

Design Details.- The decoupler pylon is illustrated in Figure 3. It consists of an upper section which is attached to the wing, and a movable lower section to which the store is attached. Connecting the two pylon sections are a two-link pitch pivoting mechanism, a leaf spring and damper, and a pitch alignment system. The two-link pivoting arrangement was unique to this General Dynamics design. Because of the two-link pivoting arrangement, the decoupler pylon could be built within the same mold lines of the standard pylon and, more importantly, the power requirements for the alignment system were easily satisfied. The latter results because the two-link pivoting mechanism has a virtual or remote pitch pivot at the GBU-8 center-of-gravity, thus, the store pitch loads due to maneuvers and aerodynamic drag are reduced from those obtained using a single pivot design. Each of the two links was pinned at the upper and lower joint. Attached to the lower pylon section was a standard MAU-12-C/A rack that was used for mounting and ejecting stores. The leaf spring stiffness was selected to lower the pylon pitch mode frequency as much as possible within practical strength limits because of the maximum predicted improvement in flutter speed.

Alignment System.- The alignment system was designed to maintain the store in a nominally aligned static position. The decoupler pylon was limited to a  $\pm 3$  degree pitch travel from the nominal, centered position. The alignment system consisted of an electric drive motor with a gear box, a drive jack screw, and on-off and travel limit switches. The system was activated when the store became misaligned from its centered position by approximately  $\pm 0.5$  degrees. When activated, the motor drove the jack screw which was attached to the aft end of the leaf spring to position the store pitch angle within a  $\pm .25$  degree deadband about the centered position. The alignment system on each pylon operated independently. Should the alignment system malfunction, limit switches deactivated the motor prior to contacting the physical limits. Electrical power was controlled from the cockpit so that the pilot could enable or disable the system as desired.

Initial Decoupler Pylon.- The initial decoupler pylon links employed pin-bushing joints. Ground tests performed on these pylons indicated that high pitching moments were required to overcome the break-out friction in the pivot joints. The friction was attributed to an adverse buildup of alignment tolerances in the hole centers that occurred when drilling separately the opposite sides of the clevis in the upper pylon part; consequently, the holes

were slightly misaligned and some pin binding resulted. This effect was further amplified by the two-link design because as the store rotates in pitch small amounts of non-parallelism in the pin holes can cause additional binding. Reference 5 details several steps taken to reduce friction including modifying the damper and using slightly undersized pins. To further reduce total friction, the viscous fluid in the damper was removed for flight. As flight tested, the pylons required an average break-out pitching moment of 4713 in-lb to overcome the friction in the pivots. Some lateral freeplay was introduced in the joints as a result of using the undersized pins. Table I lists the frequencies of interest measured in the ground vibration test performed on the aircraft prior to first flight with the initial decoupler pylons (ref.6). The GBU-8 pylon pitch mode frequency was measured at 3.92 Hz antisymmetrically and 4.08 Hz symmetrically. This mode is below the antisymmetric tip missile pitch mode frequency. By comparison, the GBU-8 pitch mode frequency on the standard pylon is 5.13 Hz antisymmetrically and 5.35 Hz symmetrically.

Modified Decoupler Pylon.- The modification to the decoupler pylon consisted of replacing the link bushings with a combination of available off-the-shelf aircraft quality roller and thrust bearings (ref. 7). The original pins were pressed out and replaced with pins with a stepped down diameter at the ends to accommodate the bearings. The modification reduced the pylon break-out pitch friction and essentially eliminated lateral freeplay. Freeplay measured at the nose of the GBU-8 was .005 in. for the left pylon and .008 in. for the right pylon. The corresponding values for the initial decoupler pylon were .120 in. and .140 in. respectively. This pylon still required an average pitching moment of 2620 in-lb to move the pylons in pitch. The modification reduced the load carrying capability of the pylon due to the reduced diameter of the pins. Measured airplane frequencies with the modified decoupler pylon are included in Table I. The GBU-8 pylon pitch mode frequency was measured now at 3.29 Hz antisymmetrically and 3.31 Hz symmetrically. A second mode, which also involved large GBU-8 pitch motion, was found at 4.30 Hz antisymmetrically and 4.24 Hz symmetrically. This mode was identified as the pylon strongback vertical bending mode. (The strongback is the major structural member of the upper part of the pylon). In these measurements the excitation was sufficient to overcome the break-out friction of the pivots and there was some pivoting at the link joints. Each of these modes is below the antisymmetric tip missile pitch mode frequency.

Instrumentation.- The decoupler pylons were instrumented to provide information on the functioning of the pylon. Strain gages were installed on the pitch springs, and a position indicator measured the relative pitch deflection between the upper and lower part of the pylon. The position of the aft end of the springs was derived from these two measurements. In addition, limit switches were placed at the up and down travel limits of the spring. When the aft end of the spring reached a limit, these switches disabled the alignment system and illuminated a light in the cockpit.

## TEST PROCEDURE

### Envelope Expansion

An envelope expansion procedure was followed in the flight tests of each pylon configuration. The test conditions were arranged in order of increasing Mach number and, consequently, dynamic pressure at each altitude. For all configurations, the Mach number envelope was completely covered at the 10,000

feet altitude before starting the tests at 5,000 feet altitude. Throughout the test program the output signals from the instrumentation were telemetered to the Ames-Dryden Structural Analysis Facility for display on stripcharts and for analysis by dedicated spectral analyzers. Power spectra were calculated to provide frequency and damping information in near real time. In addition, the peak amplitude of each critical mode was monitored as a function of airspeed. This information was used to determine if it was safe for the aircraft to proceed to the next test condition. More details on the specific procedures are given in the following sections.

### Test Conditions

Figure 4 gives the nominal test conditions which were flown with the standard pylon, the initial decoupler pylon, and the modified decoupler pylon. Flights with the GBU-8 on the standard pylon were flown at altitudes of 10,000 feet to 0.95 Mach number and at 5,000 feet to 0.90 Mach number to establish baseline data. Maneuvering test points were at 0.8 Mach number at each altitude.

Test points with the GBU-8 on the initial decoupler pylon were flown up to 0.90 Mach number at 10,000 feet. No maneuvering flights were flown because of the decision to modify the pylon.

The modified decoupler pylon was tested over the same range of test conditions as the standard pylon. Maneuvering test points were flown at the higher altitude at 0.60 and 0.80 Mach numbers. The store-ejection demonstration test was conducted at a Mach number of 0.80 and an altitude of 7,500 feet.

### Straight and Level Flight

For the standard pylon, the aircraft was stabilized at each test point for approximately 30 seconds while data were being acquired. After analysis of the data, the pilot excited the structure with pilot induced pitch, yaw, and roll stick raps. Following these pulses, the onboard excitation system was used to command a three second antisymmetric burst of the flaperons at the frequency of the limited amplitude oscillation, 5.1 Hz. The amplitude of the flaperons was  $\pm 0.5$  degrees. In addition, at the 0.4 Mach number point at each altitude a frequency sweep was performed from 20 Hz down to 2 Hz in 35 seconds with a flaperon amplitude of  $\pm 0.5$  degrees.

For the decoupler pylon flights, the aircraft was stabilized on test condition for 60 seconds of atmospheric turbulence excitation. Following analysis of these data, frequency sweeps and bursts at specified frequencies were made for amplitudes of the flaperon up to  $\pm 1$  degree. The sweep time was again 35 seconds to sweep from 20 Hz to 2 Hz. Each burst duration was 3 seconds.

### Maneuvering Flight

Wind-up turns to 4g were performed with the standard pylon to document the flutter oscillation characteristics under the effect of elevated load factors. These and additional maneuvers were performed on the modified

decoupler pylon. The additional maneuvers were abrupt pullups, pushovers to 0g, rudder kicks, and steady side slips. The rolling maneuvers which had been planned for the program were eliminated due to a reduced load carrying capability of the modified pins. The on-board excitation system was not used during maneuvers.

### Alignment System Flight

After the straight and level and maneuvering flight testing of the modified decoupler pylon was accomplished with the alignment system disabled, the system was activated. Slow straight and level accelerations out to the limits of the flight envelope were flown first, followed by maneuvers at the prescribed test points. The onboard excitation system was not used during these tests.

### GBU-8 Store Separation Flight

For the GBU-8 separation flight, the aircraft was configured with the GBU-8 mounted on the right modified decoupler pylon, an unloaded decoupler pylon on the left wing, and AIM-9J missiles on each wingtip. The right dummy AIM-9 carried high-speed movie cameras to make a visual record of the store ejection sequence. The store was ejected from a straight and level flight attitude.

## RESULTS AND DISCUSSION

### Standard Pylon Flights

The F-16 configured with standard pylons was tested first at 10,000 feet altitude. At Mach numbers above 0.70, this configuration experienced an antisymmetric 5.1 Hz limited amplitude flutter oscillation. The flight determined flutter boundary is shown on Figure 4. Figure 5 is a strip chart record of the flaperon position and several wingtip and GBU-8 accelerometer channels at a Mach number of 0.90. The figure shows a sample time history of the oscillation amplitude levels under ambient excitation, followed by a forced excitation (control system burst), and the subsequent return to ambient conditions. In ambient turbulence, the oscillation is evident on the accelerometer responses and involves predominantly pylon pitch and tip missile pitch with some wing bending motions. Damping is zero. Pilots described the oscillation as a continual pounding oscillation which was of sufficient amplitude to cause visual blurring of the cockpit displays. Analysis had indicated that this flutter resulted from a coalescing of the pylon pitch mode with the tip missile pitch mode.

At each test point, the structure was excited antisymmetrically with a 5.1 Hz burst using the on-board excitation system, as indicated in Figure 5. The result was to increase the amplitude of the oscillation. Upon termination of the forced excitation, the oscillation would decay to the amplitude that existed before the excitation commenced. Thus, the flutter phenomena exhibits nonlinear behavior with damping being a function of amplitude.



Figure 6 compares the forced and unforced oscillation amplitude of a wingtip and a GBU-8 normal (vertical) accelerometer as a function of Mach number. At 10,000 ft. altitude, the flutter oscillation starts at  $M = 0.70$  and the oscillation amplitude increases with increasing Mach number ( $M$ ), reaching a maximum at approximately  $M = 0.93$ , and then decreases with Mach number to  $M = 0.96$ , the maximum test value. At 5,000 feet altitude, the flutter starts at Mach number 0.78, and the oscillation amplitude increases with Mach number to the maximum Mach number tested,  $M = 0.90$ . The initiation of the oscillation at this particular Mach number at 5000 ft. altitude was an unexpected result because early Air Force tests (results unpublished) had indicated that the oscillation would begin at a lower Mach number. The reason for this disagreement is not known. However, it was observed that the present flight test at 10,000 feet was performed in smooth air while the flight at 5,000 feet, on a different day, was performed in light turbulence. Another difference noted was that turbulence tended to perturb the oscillation so that the oscillation was not as regular at 5,000 feet as it had been at 10,000 feet. For this reason, the results which follow are mainly for at the 10,000 feet test conditions.

The wind-up turns to a load factor of 4g that were performed at 0.8 Mach number at both altitudes indicated that the amplitude of the oscillation increased with increasing load factor. The amplitude at 4g was approximately twice the amplitude of the oscillation at 1g (straight and level flight).

#### Initial Decoupler Pylon

The standard pylons for the GBU-8 store were replaced by the initial decoupler pylons. Flight tests of this configuration were made at Mach numbers up to 0.90 at the 10,000 ft. altitude only. The limited amplitude flutter oscillation that occurred with the standard pylons was suppressed by the initial decoupler pylons throughout the flight envelope tested.

Although flutter was suppressed, the pylon pitch motions during flight were affected by the friction in the pylon link pivots. The primary frequency on the GBU-8 normal accelerometer was 4.8 Hz to 5.0 Hz under atmospheric turbulence excitation. This frequency was identified as that of the pylon strongback bending mode, with little if any pitching of the pylon about its pivots. For forced excitation using the control system, the frequency of maximum response was from 4.4 Hz to 4.7 Hz, and some limited pitching of the pylon about its pivots was observed. The flutter suppression was attributed to the fact that the initial decoupler pylon was more flexible in pitch than the standard pylon. Consequently, the frequency of the store pitch mode was lower and more frequency separation from the tip missile pitch mode frequency was provided than with the standard pylon.

Figure 7 is a power spectral density (PSD) presentation of the left launcher forward accelerometer response at the 0.90 Mach number and 10,000 feet condition. Response peaks at several frequencies are indicated in the range from 3.5 Hz to 6.0 Hz for the decoupler pylon (fig. 7(a)), whereas the standard pylon PSD has a single strong peak at about 5.1 Hz (fig.7(b)), which was the frequency of the limited amplitude flutter. All peak PSD response levels are greatly lower for the decoupler pylon, due to the flutter suppression of the decoupler pylon. The root mean square acceleration calculated from each PSD over the .1 Hz to 25 Hz range is 0.67g for the standard pylon but only 0.08g for the decoupler pylon.

Presented in figure 8 are the variations in frequency and damping with Mach number for three different modes measured during the tests of the initial decoupler pylon at 10,000 feet altitude. The modes are the antisymmetric tip missile pitch mode, the pylon strongback mode, and the antisymmetric first wing bending mode. Structural damping coefficient,  $g$ , values are plotted. All modes are well damped. (The tip missile pitch mode for the standard pylon has zero damping above 0.70 Mach number). There is an indicated trend of decreasing stability (damping) in the pylon strongback mode with increasing Mach number, but the damping values are still considered more than adequate for flight safety. The characteristics of the decoupler pylon modes above 0.90 Mach number were not determined due to the decision to modify the pylon.

The damping and frequency variations with Mach number of the pylon pitch mode for a forced burst excitation are given in Figure 9 for the left and right decoupler pylon. The data indicate that the left pylon has less damping than the right pylon, that the degree of stability of each pylon mode is decreasing, and that the frequency is close to the pylon strongback mode frequency. A difference in damping between the left and right initial decoupler pylon was also noted in ground tests which showed that the left pylon had less friction than the right pylon.

#### Modified Decoupler Pylon

For both the initial and modified decoupler pylon, forced excitation tests were made during flight to determine if the pylon linkages were, in actual practice, pivoting as designed and contributing to the GBU-8 store pitch motion. (This was a concern because of the friction in the pylon linkage joints). As an indication of the linkage contribution, the relative pitch angular movement between the upper and lower pylon sections was measured. Figure 10 compares the oscillatory pylon (or store) pitch angles attributed to the link rotation for each pylon configuration when excited at the frequency of maximum store pitch response and at various force amplitudes. For the initial decoupler pylon, store pitch motion could not be achieved except to a very limited degree and the maximum store response occurred near 4.5 Hz (4.4-4.7 Hz), which was near the pylon strongback mode frequency. For the modified pylon, however, the maximum response occurred near 3.6 Hz which was the antisymmetric GBU-8 pitch mode frequency. At Mach number 0.80 and above, the modified pylon had a much greater response amplitude than the initial pylon at the same force level indicating that there was linkage rotation with the modified decoupler pylon. In the modified pylon tests, the predominant store response occurred in the low frequency store pitch mode for atmospheric turbulence also. Therefore, the modified decoupler pylon appeared to be functioning as designed although it has more friction than desired. Because the strongback was common to both the initial and modified design, the flutter suppression mechanism of the modified decoupler pylon would involve both the store pitch mode and the strongback bending mode, each of which had frequencies below that for the standard pylon. The experience with the initial and modified decoupler pylons highlights the possible friction problems associated with pivots. Any production decoupler pylon should be designed to ensure freedom in the pivoting mechanism and emphasize maintainability of the pivots in field service.

Figure 11 shows the variation of frequency and damping with Mach number of four vibration modes tracked during the modified pylon flight tests.

These modes were the antisymmetric tip missile pitch mode, the store pitch mode, the pylon strongback mode, and the antisymmetric first wing bending mode. The damping estimates were made during stabilized test conditions. The absence of data for the store pitch mode and the pylon strongback mode at some Mach numbers is a result of the low response in these modes at these test conditions and a resultant signal-to-noise ratio too low to obtain meaningful damping measurements. All modes are well damped with no indication of the decreasing stability in the strongback bending mode that was seen in the initial decoupler pylon tests. Flutter was suppressed by the modified decoupler pylon throughout the flight test envelope at 10,000 feet and 5,000 feet. The increase in flutter speed at 10,000 feet was therefore demonstrated to be at least 37 percent.

A power spectral density of the left launcher forward normal accelerometer response at the Mach number 0.90 and 10,000 feet condition is given in Figure 12. The predominant mode indicated here is at 3.6 Hz which here is the symmetric first wing bending mode. This test condition probably was flown in light turbulence. The root mean square acceleration response from .1 to 25 Hz is 0.19 g's. This compares to equivalent rms values for the initial decoupler pylon and standard pylon of 0.08g's and 0.67g's respectively.

Maneuvering flight.- Numerous maneuvers were accomplished with the modified decoupler pylon to evaluate store pitch displacements. There was no indication of flutter during any maneuver. The test data indicated that the greatest pylon pitch angle excursion for any maneuver with the alignment system disabled was about 0.8 degrees store nose-up. This excursion occurred during an abrupt pull-up maneuver at 0.8 Mach number for which data are shown in Figure 13. Other test results indicated that the pylon pitched nose-up with increasing load factor such as during wind-up turns and abrupt pull-ups. Other characteristics observed were that the left store pitched nose-up for airplane nose-left side slips and rudder kicks, while the right store pitch angle remained essentially constant during these maneuvers. For nose-right side slips and rudder kicks, similar behavior was observed, but on the opposite side of the airplane.

Alignment system.- The alignment system performed as designed throughout the flight envelope and during maneuvers. The left and right pylon alignment system motors operated independently and were set to maintain a store pitch position within allowable limits of roughly  $\pm 5$  degrees. One example of system operation is shown in Figure 14 which shows pylon pitch angle variations with Mach number during accelerated level flight from 0.40 Mach number to 0.94 Mach number at 10,000 feet. The results are shown for the system enabled and also when disabled. During acceleration with the alignment system disabled, the stores gradually pitch nose down with increasing Mach number (Fig. 14(a)). Above Mach number 0.90, however, the store pitches nose up rapidly with Mach number due to the change in aerodynamic loading in the transonic region. When enabled (fig. 14(b)), the alignment system activated once, near  $M = .74$  (left pylon) and  $M = .75$  (right pylon), to bring the store nose up when the downward limit was exceeded, and a second time on only the left pylon near  $M = .88$  when the downward limit was again exceeded. Only the left pylon system activated a third time at the upper limit to bring the store nose down to counteract the effects of the transonic airloads on the static store position.

The alignment system was originally incorporated to prevent the store from contacting the physical pitch limits at  $\pm 3$  degrees.

excursions measured during maneuvers and over the flight test envelope probably would not justify the complexity or expense of incorporating an alignment system in a production decoupler pylon for this configuration. Moving the store center of gravity either fore or aft from the current position would result in greater pitch excursions, however.

Store ejection.- One flight was made to eject the GBU-8 store from the modified decoupler pylon during straight and level flight at 0.80 Mach number and 7500 feet altitude. The store separated cleanly from the pylon and flew a nominal trajectory. A review of high speed movies of the separation revealed that the GBU-8 separation characteristics were similar to those for the standard pylon.

#### CONCLUDING REMARKS

Flight tests were performed on an F-16 loaded on each wing with an AIM-9J wingtip missile, a GBU-8 bomb near midspan, and a one-half full (center bay empty) 370-gallon fuel tank mounted on the inboard wing station. This configuration was flown with the GBU-8 mounted on a standard pylon, an initial decoupler pylon, and a modified decoupler pylon.

The standard pylon baseline flights established the flutter boundary at Mach number 0.70 at 10,000 feet and at Mach number 0.78 at 5,000 feet. At and above these test conditions, a 5.1 Hz. antisymmetric limited amplitude flutter was experienced. The amplitude of the oscillation at 10,000 feet increases with increasing Mach number to  $M = 0.93$  and then decreases to  $M = 0.96$ . At 5,000 feet, the amplitude increase to  $M = 0.91$ , the maximum Mach number tested.

The initial decoupler pylons were flown on the F-16 in straight and level flight to 0.90 Mach number at 10,000 feet. The limited amplitude flutter experienced with the standard pylon was suppressed throughout the flight envelope tested. Because of excessive friction in the pivot joints, there was little if any pitching about the pivots. The flutter suppression mechanism was attributed to the stiffness of the upper pylon portion which even with the joint friction provided a lower store pitch frequency than was obtained with the standard pylon. This lower frequency mode provided sufficient frequency separation from the tip missile pitch mode frequency to eliminate flutter.

When the decoupler pylons were modified by adding bearings at the pivot joints, the friction was reduced by an average of 43 percent and the lateral freeplay in the pivots was virtually eliminated. Flight tests, including maneuvers, were conducted throughout the operational envelope without encountering any flutter, thus demonstrating an increase in flutter velocity of 37 percent over the standard pylon configuration. The test results indicated that the pylon was responding primarily in a new lower frequency store pitch mode which involved significant pylon pitching about the pivots. The flutter suppression mechanism was attributed to the two low frequency pylon modes which again provided sufficient frequency separation from the tip missile pitch mode frequency to eliminate flutter.

Only small store pitch deflections were recorded due to maneuver loads and airloads. These results indicated that an alignment system may not be required for this decoupler pylon. When the alignment system was enabled, it

A GBU-8 was ejected during one flight test and demonstrated that weapon separation from the decoupler pylon is normal.

#### References

1. Reed, Wilmer H., III; Foughner, Jerome T., Jr.; and Runyan, Harry L., Jr.: Decoupler Pylon: A Simple, Effective Wing/Store Flutter Suppressor. J. Aircraft, Vol. 17, No. 3, March 1980, pp. 206-211.
2. Reed, Wilmer H., III; Cazier, F. W., Jr.; and Foughner, Jerome T., Jr.: Passive Control of Wing/Store Flutter. NASA TM-81865, 1980.
3. Cazier, F. W., Jr.; and Foughner, Jerome T., Jr.: NASA Decoupler Pylon Program for Wing/Store Flutter Suppression. Presented at Tactical Aircraft Research and Technology Conference, Hampton, Virginia, October, 1980. NASA CP-2162, Vol. I, part 1, pp. 207-218.
4. Peloubet, R. P., Jr.; Haller, R. L.; and McQuien, L. J.: Feasibility Study and Conceptual Design of the NASA Decoupler Pylon for the F-16 Aircraft. NASA CR-165834, 1982.
5. Clayton, J. D.; Haller, R. L.; and Hassler, J. M., Jr.: Design and Fabrication of the NASA Decoupler Pylon for the F-16 Aircraft. NASA CR-172354, 1985.
6. Cazier, F. W., Jr.; and Kehoe, M. W.: Ground Vibration Test of F-16 Airplane With Initial Decoupler Pylon. NASA TM-86259, 1984.
7. Clayton, J. D.; Haller, R. L.; and Hassler, J. M., Jr.: Design and Fabrication of the NASA Decoupler Pylon for the F-16 Aircraft, Addendum II. NASA CR-172494, 1985.
8. Cazier, F. W., Jr.; and Kehoe, M. W.: Ground Vibration Test of F-16 Airplane with Modified Decoupler Pylons. NASA TM-87634, 1986.

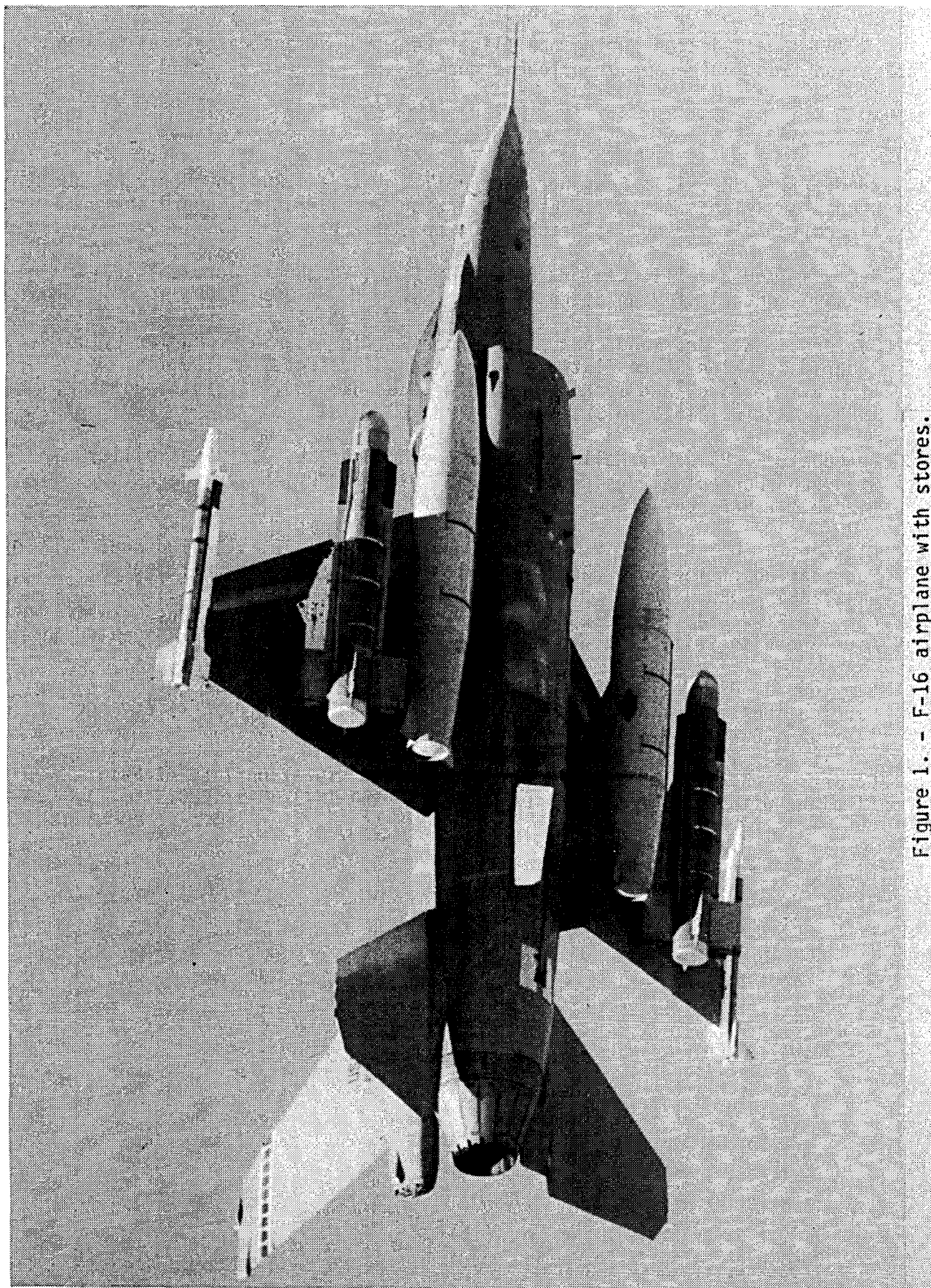

Figure 1. - F-16 airplane with stores.

1. Right 370-gallon tank normal accelerometer
2. Right 370-gallon tank lateral accelerometer
3. Right GBU-8 normal accelerometer (A3)
4. Right GBU-8 lateral accelerometer
5. Right forward wingtip launcher normal accelerometer (A5)
6. Right aft wingtip launcher normal accelerometer
7. Right flaperon position transducer
8. Right horizontal stabilizer normal accelerometer
9. Right horizontal stabilizer position transducer
10. Vertical fin lateral accelerometer
11. Rudder position transducer
12. Left horizontal stabilizer position transducer
13. Left horizontal stabilizer vertical accelerometer
14. Left flaperon position transducer
15. Left aft wingtip launcher normal accelerometer
16. Left forward wingtip launcher normal accelerometer (A16)
17. Left GBU-8 normal accelerometer (A17)
18. Left GBU-8 lateral accelerometer
19. Left 370-gallon tank normal accelerometer
20. Left 370-gallon tank lateral accelerometer

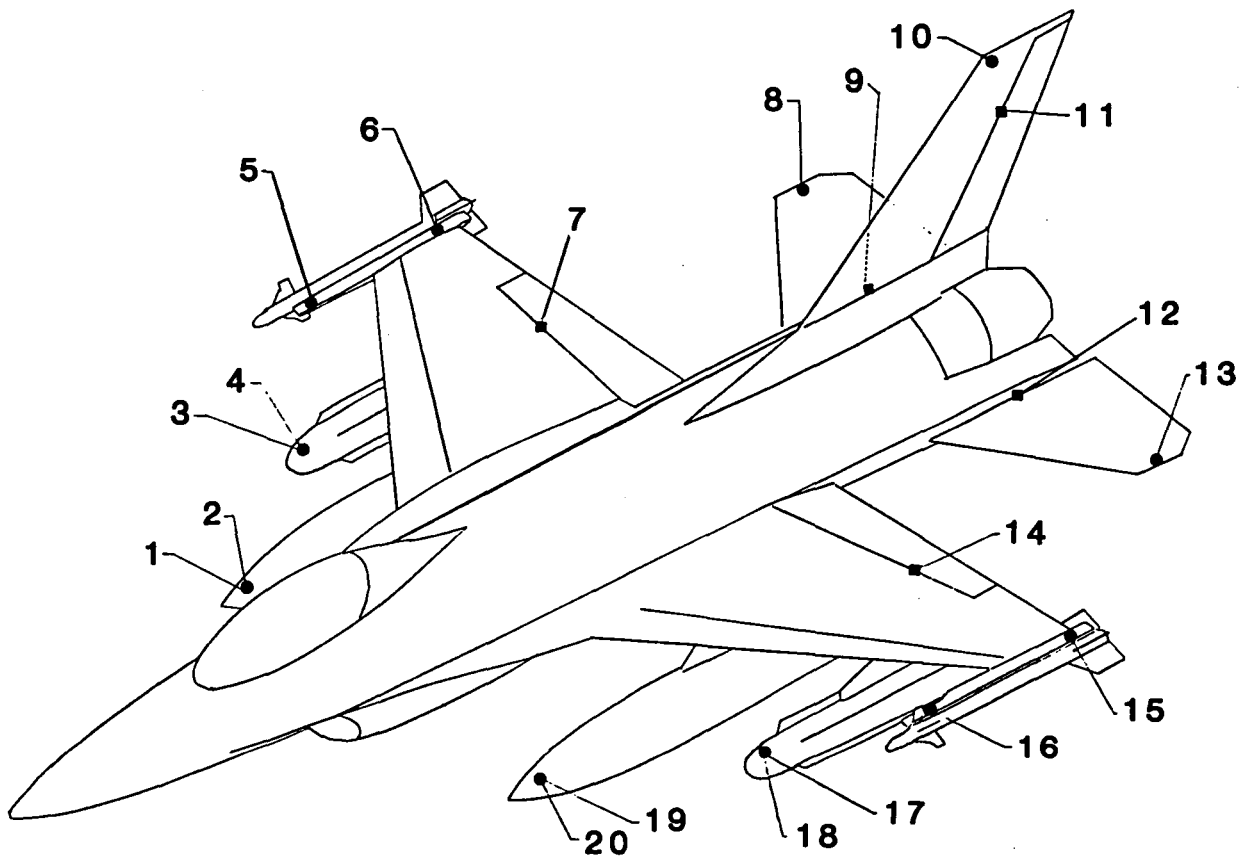

Figure 2. - Airplane flutter instrumentation.

(14)

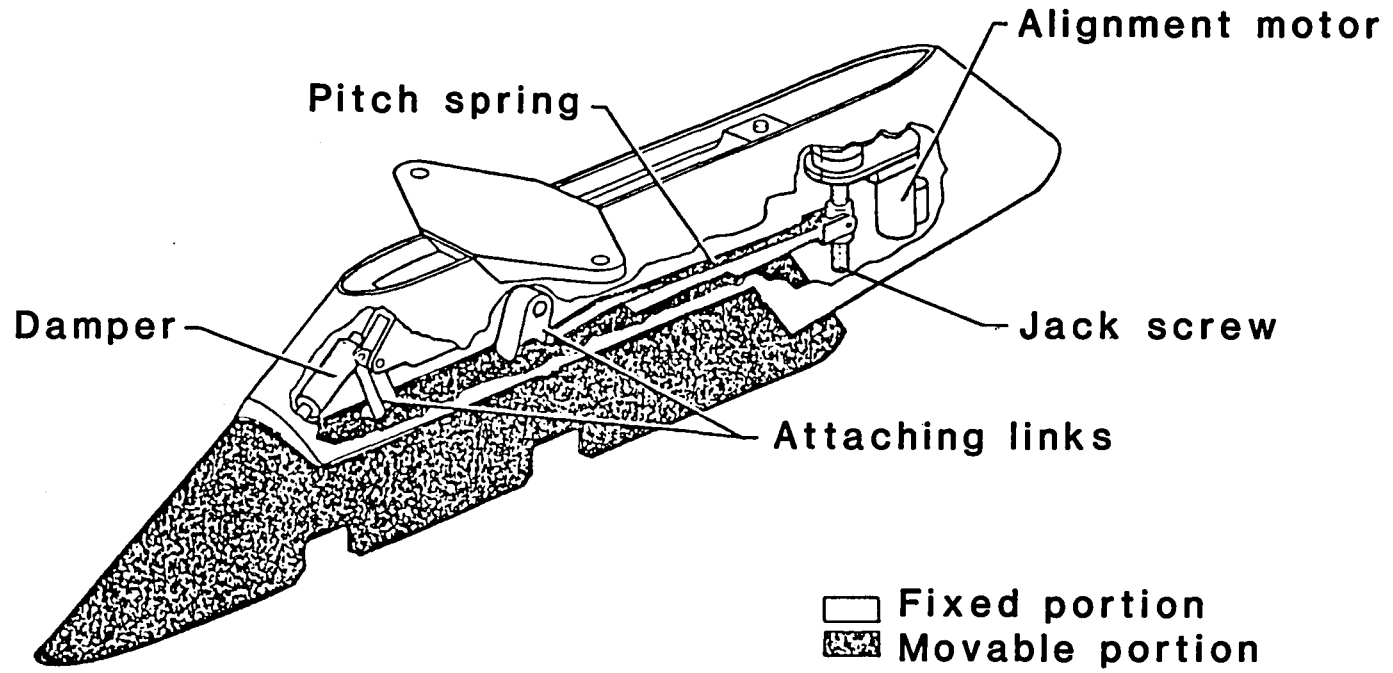
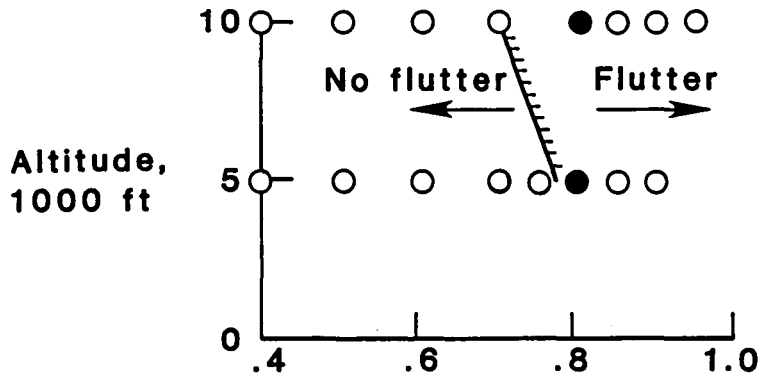

Figure 3. - Decoupler pylon components.



- Straight and level
- Straight and level and maneuvers
- Store ejection



(a) Standard pylon.

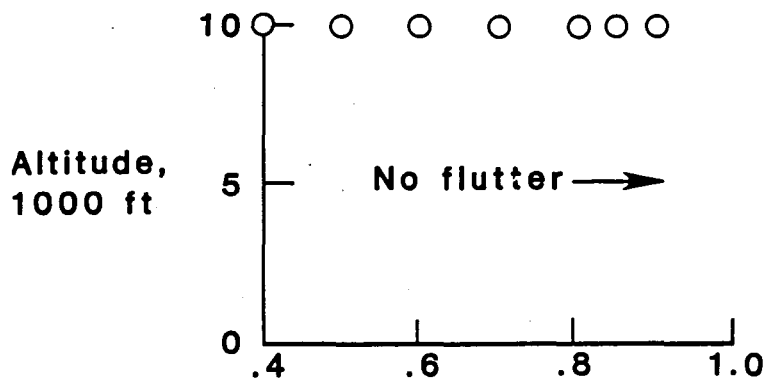

(b) Initial decoupler pylon.

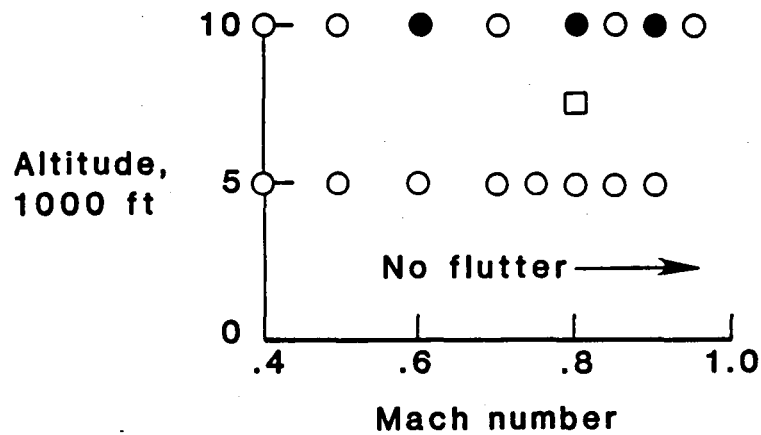

(c) Modified decoupler pylon.

Figure 4. - Nominal flight test conditions.

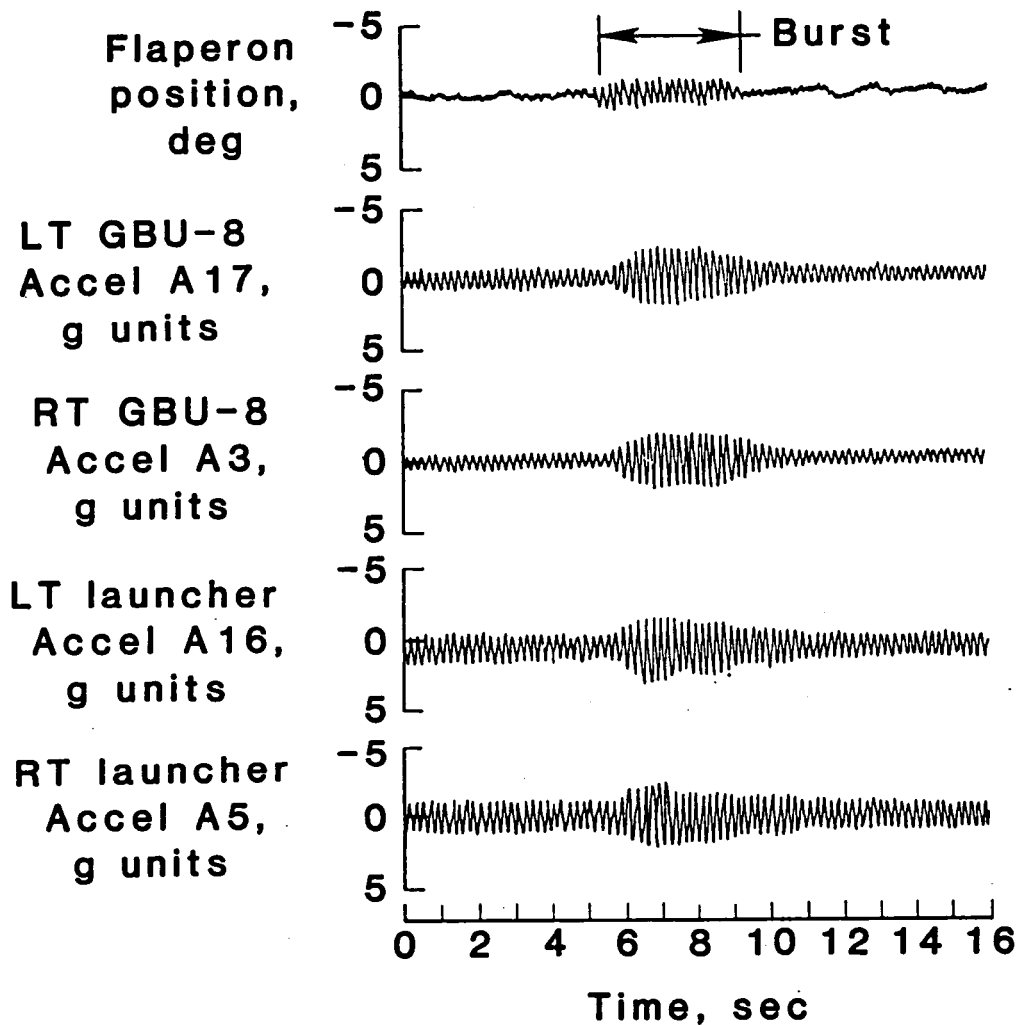
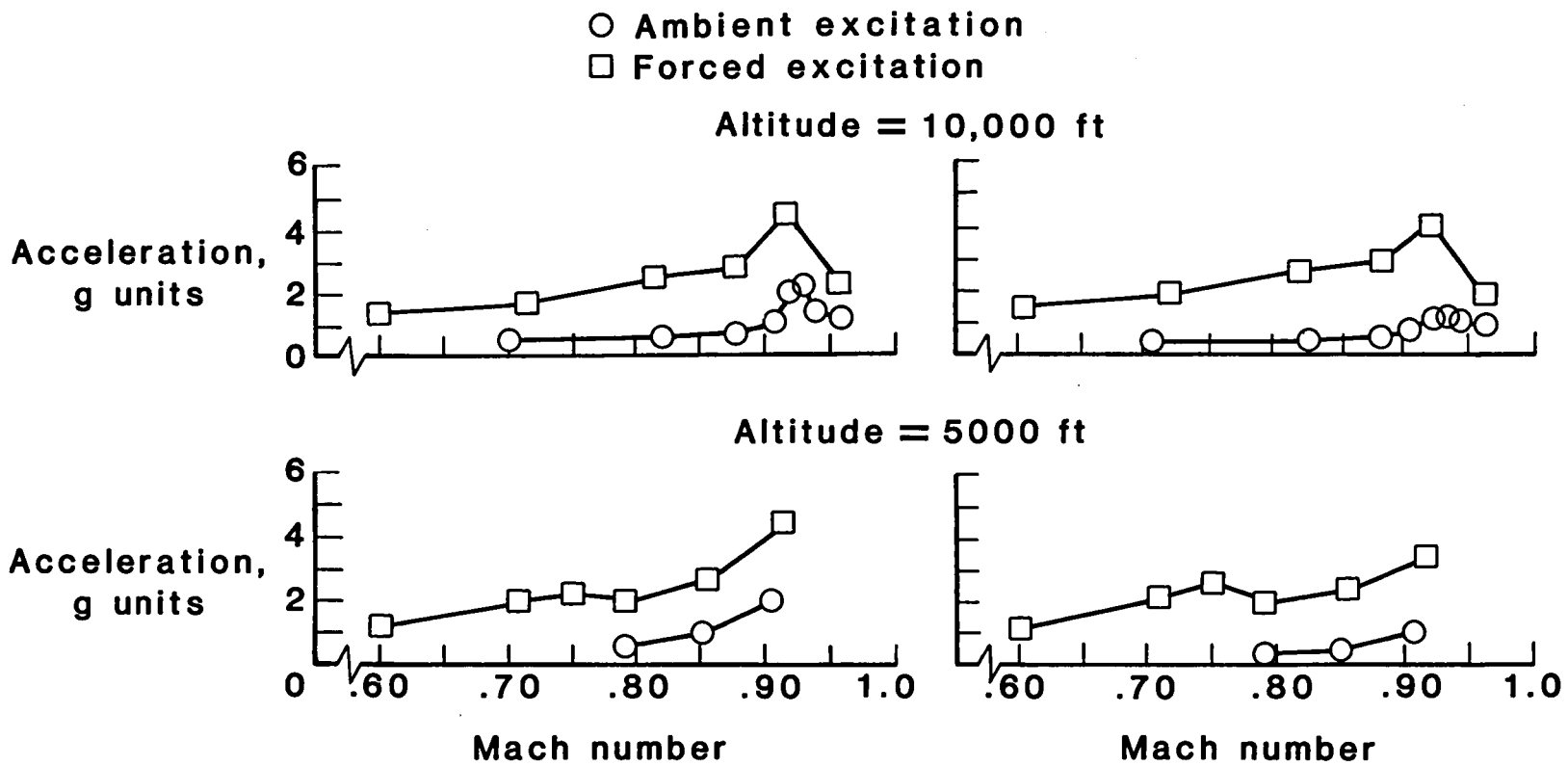

Figure 5. - Flight data showing flutter oscillation and excitation burst.  
 Standard pylon configuration,  $M = .90$ , Altitude = 10,000 feet.

(17)



(a) Right wingtip launcher forward accelerometer (A5).

(b) Right GBU-8 accelerometer (A3).

Figure 6. - Measured amplitude (peak to peak) of 5.1 Hz oscillation. Standard pylon configuration.

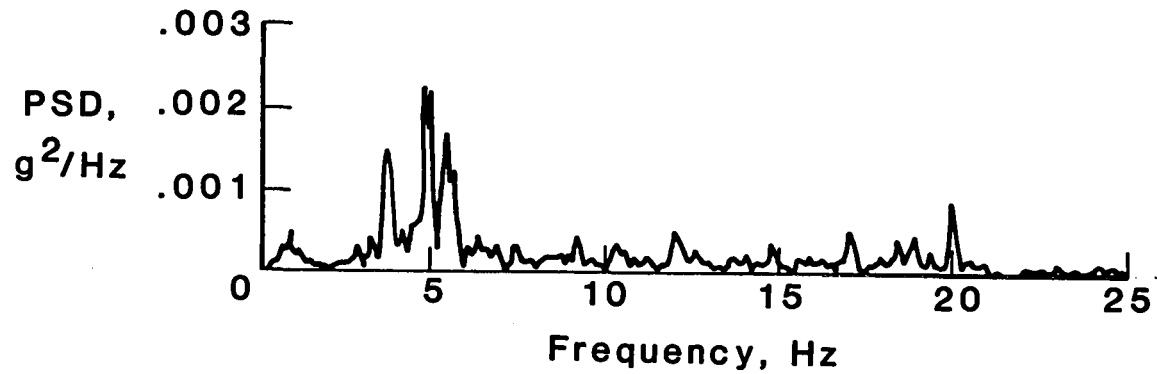

(a) Configuration with initial decoupler pylons.

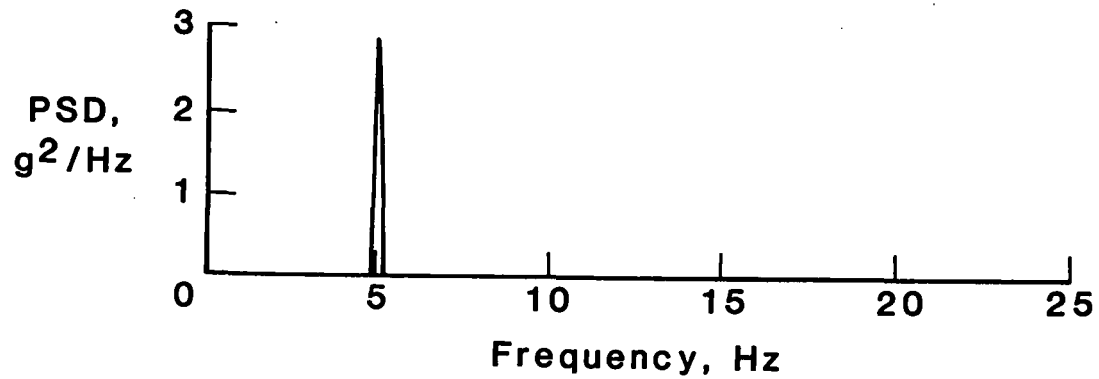

(b) Configuration with standard pylons.

Figure 7. - Measured power spectral densities of left launcher forward accelerometer (A16).  $M = 0.90$ , Altitude = 10,000 feet.

- Tip missile pitch
- First wing bending
- △ Pylon strongback bending

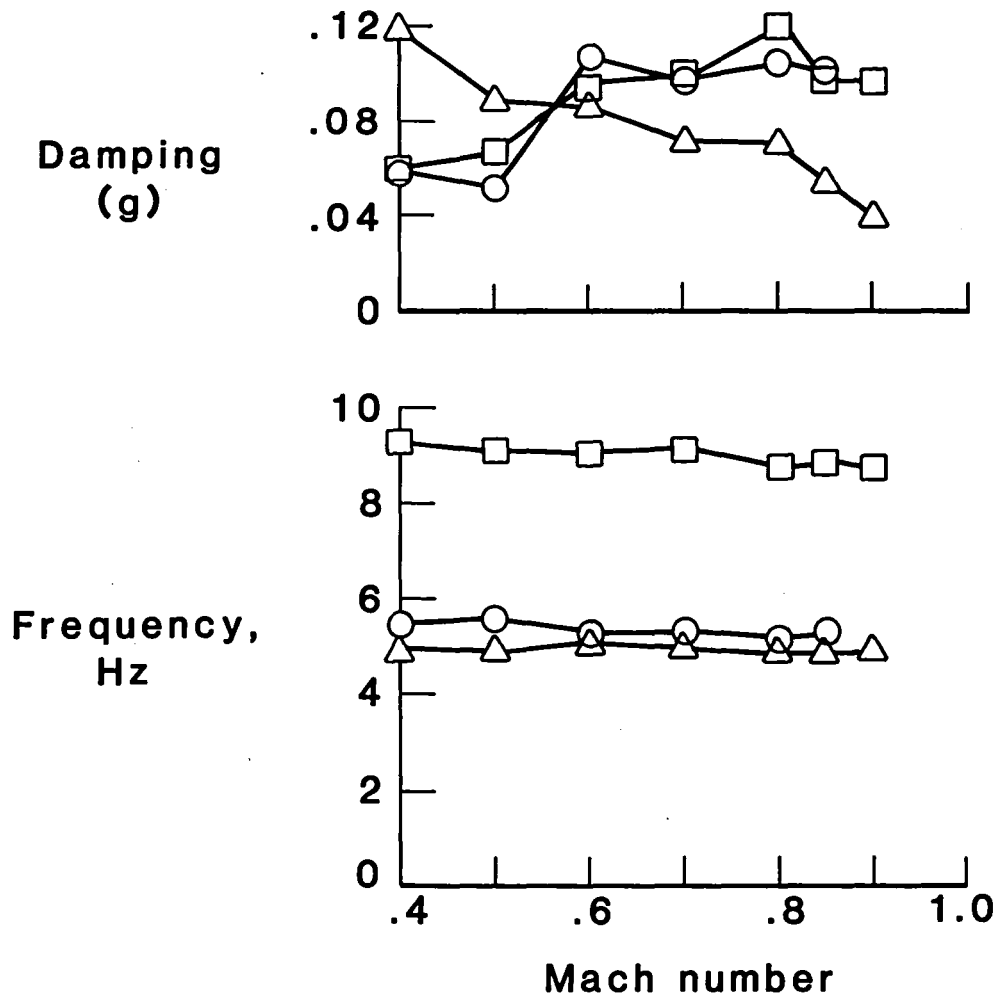

Figure 8. - Variation of frequency and damping for three antisymmetric modes. Initial decoupler pylon, Altitude = 10,000 feet.

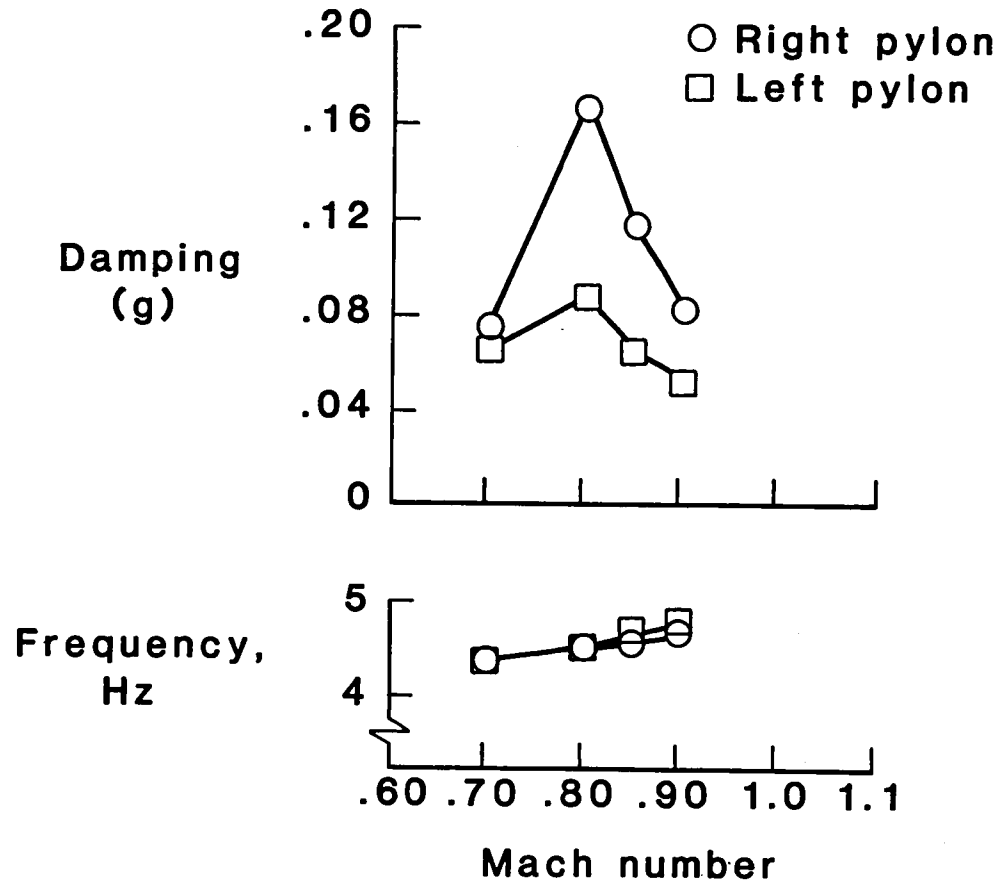

Figure 9. - Variation of frequency and damping of pylon pitch mode for control system burst excitation. Initial decoupler pylon, Altitude = 10,000 feet.

(21)

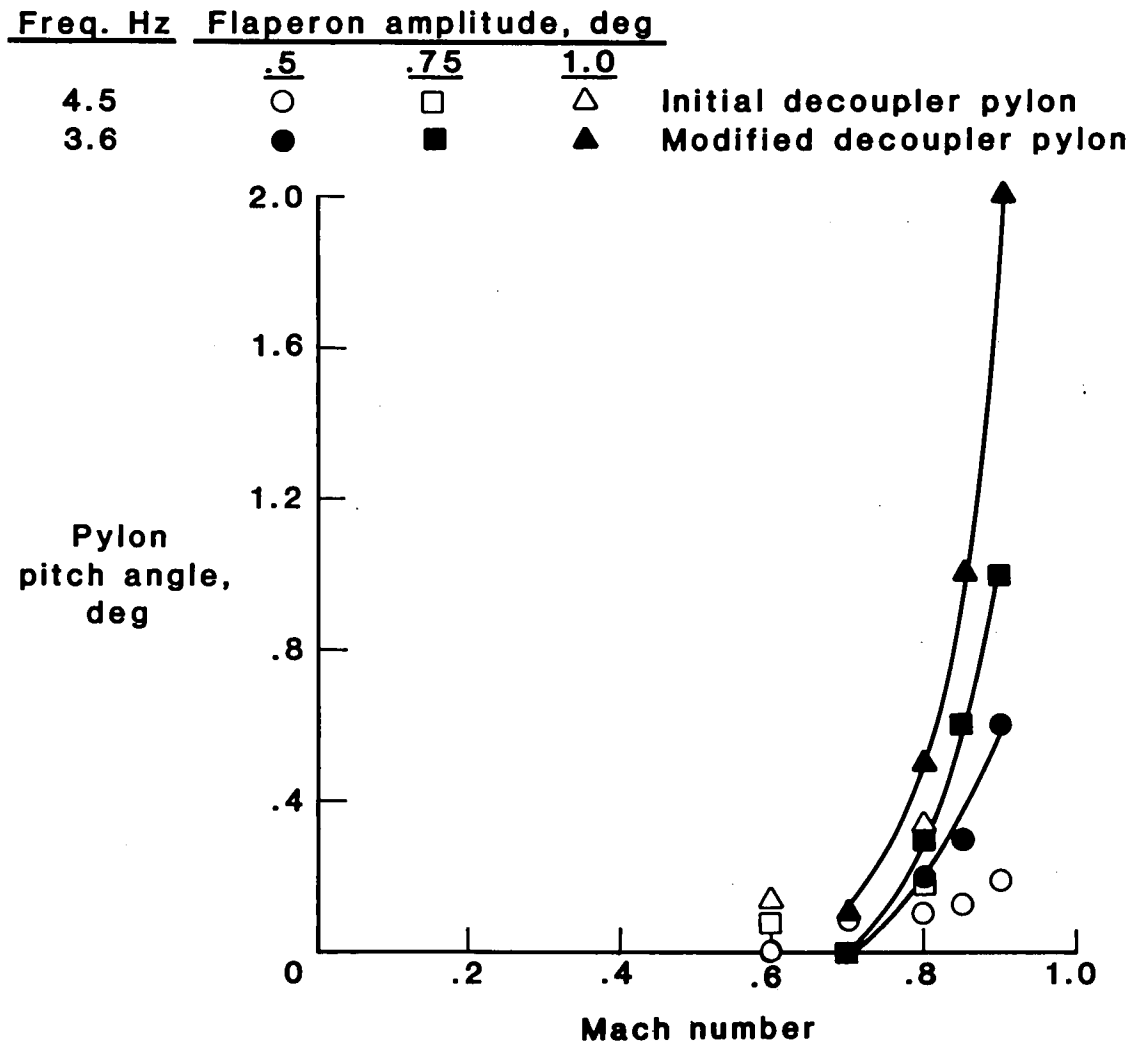

Figure 10.- Pylon pitch angle (peak to peak) during antisymmetric forced excitation. Altitude = 10,000 feet.

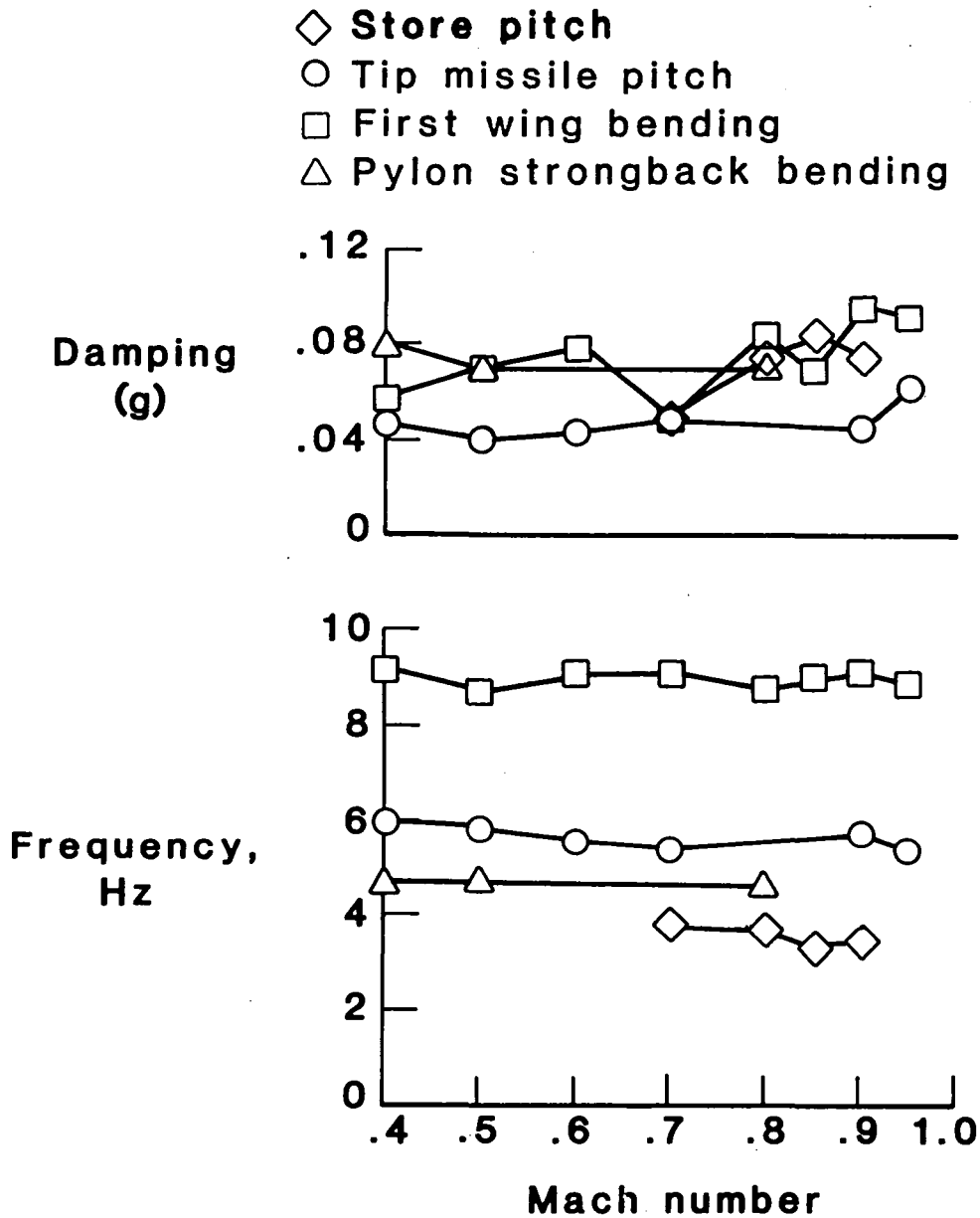

Figure 11.- Variation of frequency and damping for four antisymmetric modes. Modified decoupler pylon, Altitude = 10,000 feet.



(23)

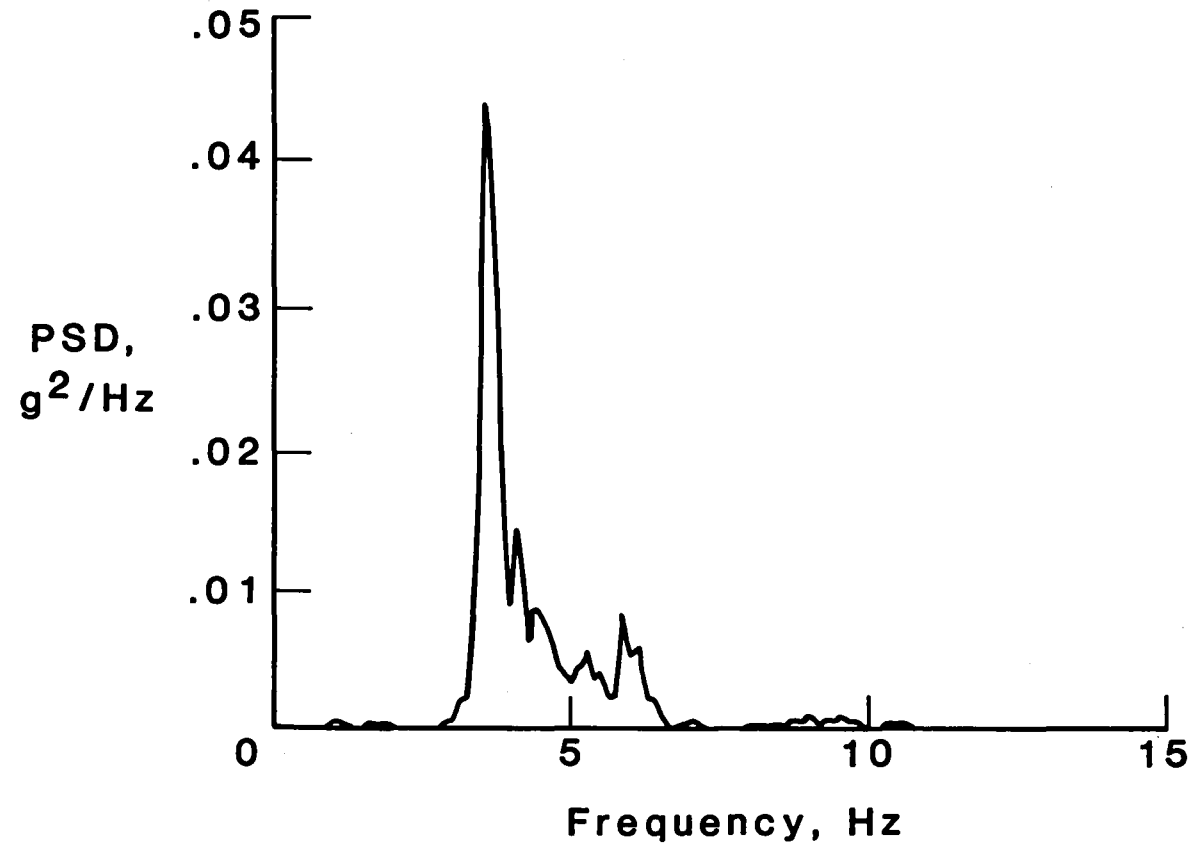

Figure 12. - Power spectral density of left launcher forward accelerometer (A16).  
Modified decoupler pylon,  $M = 0.90$ , Altitude = 10,000 feet.

(24)

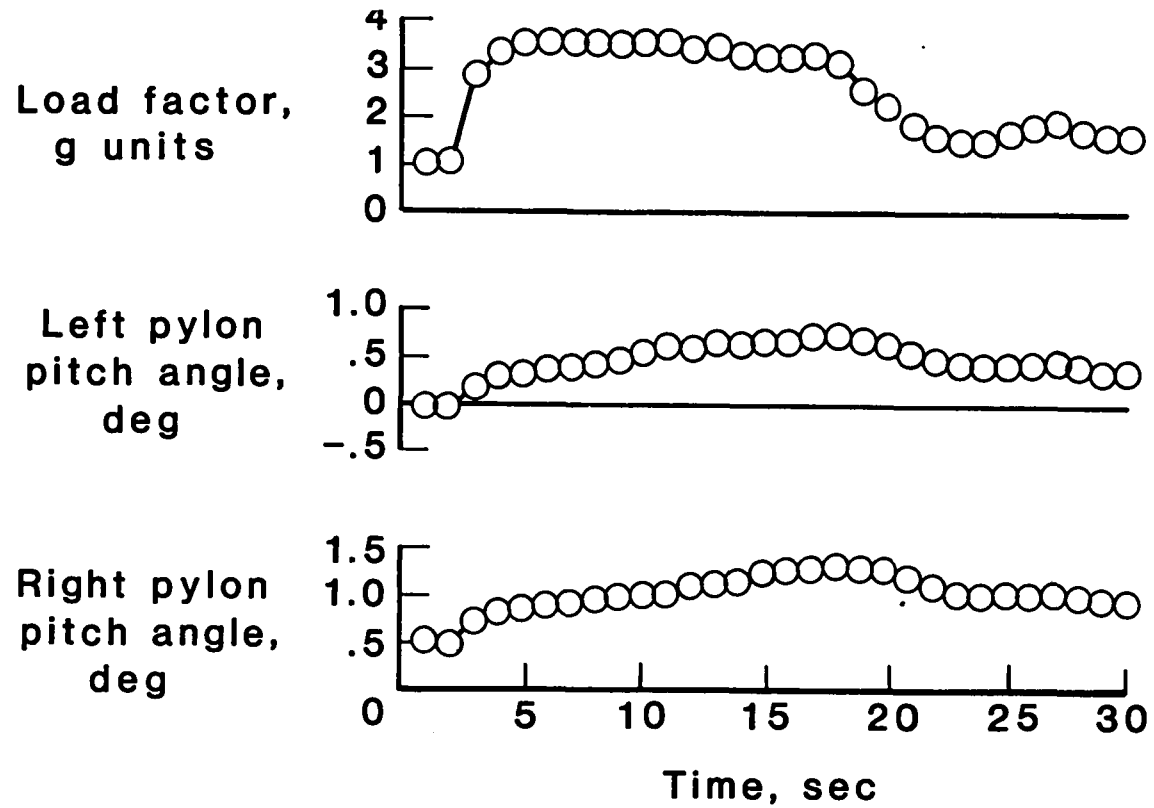
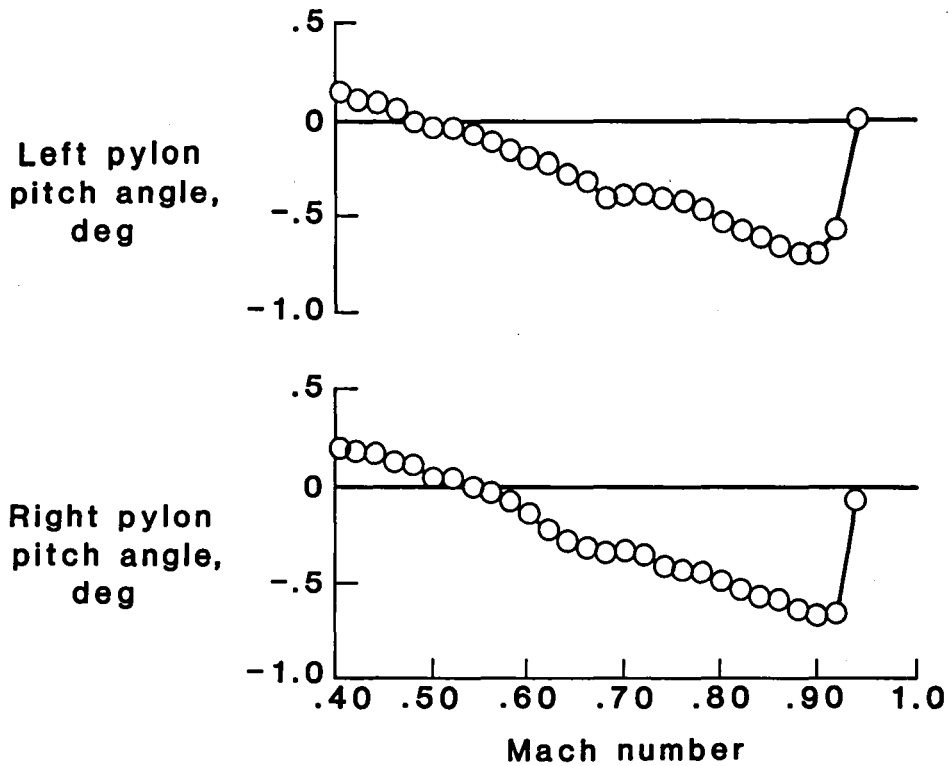
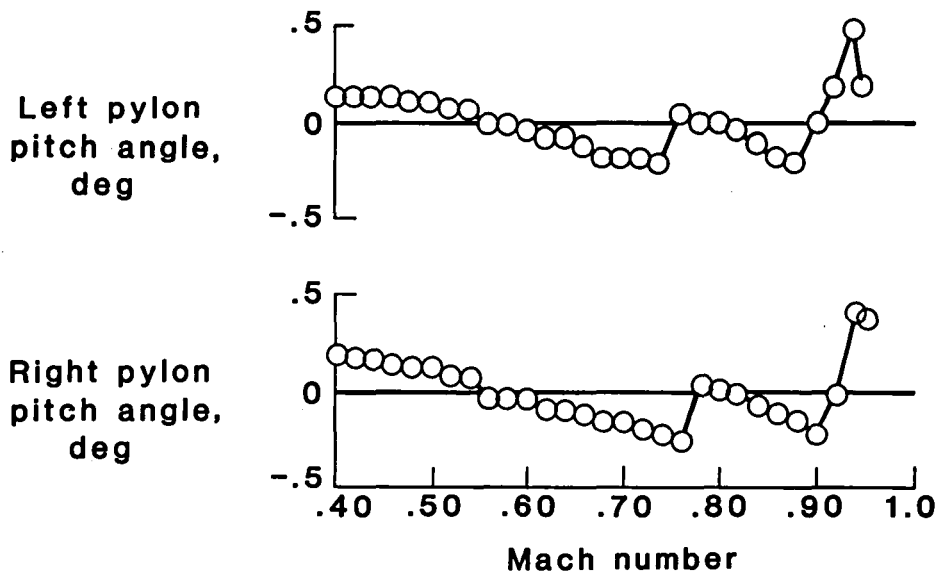

Figure 13.- Time histories during abrupt pullup maneuver.  
Modified decoupler pylon,  $M = 0.80$ , Altitude = 10,000 feet.  
Alignment system off.



(a) Alignment system disabled.



(b) Alignment system enabled.

Figure 14. - Variation of store pitch angle with Mach number.  
Altitude = 10,000 feet.

Standard Bibliographic Page

1. Report No. NASA TM-87766		2. Government Accession No.		3. Recipient's Catalog No.	
4. Title and Subtitle  Flight Test of Passive Wing/Store Flutter Suppression				5. Report Date August 1986	
				6. Performing Organization Code 505-33-43	
7. Author(s) F. W. Cazier, Jr. and M. W. Kehoe				8. Performing Organization Report No.	
				10. Work Unit No.	
9. Performing Organization Name and Address  NASA Langley Research Center Hampton, VA 23665-5225				11. Contract or Grant No.	
				13. Type of Report and Period Covered Technical Memorandum	
12. Sponsoring Agency Name and Address National Aeronautics and Space Administration Washington, DC 20596-001				14. Sponsoring Agency Code	
15. Supplementary Notes F. W. Cazier, Jr.: Langley Research Center, Hampton, Virginia M. W. Kehoe: Ames-Dryden Flight Research Facility, Edwards, California This paper was presented at the 1986 Aircraft/Stores Compatibility Symposium, Wright-Patterson A.F.B., OH, April 8-10, 1986					
16. Abstract  Flight tests were performed on an F-16 airplane carrying on each wing an AIM-9J wingtip missile, a GBU-8 bomb near midspan, and an external fuel tank. Baseline flights with the GBU-8 mounted on a standard pylon established that this configuration is characterized by an antisymmetric limited amplitude flutter oscillation within the operational envelope. The airplane was then flown with GBU-8 mounted on the decoupler pylon. The decoupler pylon is a NASA concept of passive wing-store flutter suppression achieved by providing a low store- pylon pitch frequency. The decoupler pylon successfully suppressed wing-store flutter throughout the flight envelope. A 37 percent increase in flutter velocity over the standard pylon was demonstrated. Maneuvers with load factors to 4g were performed. Although the static store displacements during maneuvers were not sufficiently large to be of concern, a store pitch alignment system was tested and performed successfully. One GBU-8 was ejected demonstrating that weapon separation from the decoupler pylon is normal.					
17. Key Words (Suggested by Authors(s))  Flutter Flight Test Decoupler Pylon Stores				18. Distribution Statement  Unclassified - Unlimited Subject Category 05	
19. Security Classif.(of this report) Unclassified		20. Security Classif.(of this page) Unclassified		21. No. of Pages 26	22. Price A03

For sale by the National Technical Information Service, Springfield, Virginia 22161

**End of Document**