

N 8 6 - 3 3 0 0 7

SOME COMPUTATIONAL TECHNIQUES FOR ESTIMATING
HUMAN OPERATOR DESCRIBING FUNCTIONS

(Informal Paper)

by

William H. Levison
BBN Laboratories Incorporated
10 Moulton St.
Cambridge, MA 02238

Proceedings of the
Twenty-First Annual Conference on Manual Control
June 17-19, 1985
Ohio State University, Columbus, Ohio

ABSTRACT

Computational procedures for improving the reliability of human operator describing functions are described. Special attention is given to the estimation of standard errors associated with mean operator gain and phase shift as computed from an ensemble of experimental trials. This analysis pertains to experiments using sum-of-sines forcing functions. Both open-loop and closed-loop measurement environments are considered.

INTRODUCTION

Linear analysis of human operator response behavior is complicated by the presence of operator "remnant"; i.e., by response components that cannot be related to the input signal by a time-invariant linear process. Remnant may arise from a multiplicity of sources, such as nonlinearities in the response strategy, time variations in the linear aspect of the response strategies, and purely stochastic response behavior.

Experiments designed to measure and model operator behavior in closed-loop control tasks have made considerable use of external forcing functions constructed as sums of sinusoids. This technology has recently been applied to the measurement of physiologic response as well.

Among the potential advantages of the sum-of-sines (SOS) technique are:

1. Describing functions can be obtained without averaging cross-spectral quantities.
2. Concentration of input power at a few select frequencies enhances the reliability of the describing function measurements at those frequencies.
3. Estimation of remnant power is enhanced.
4. Comparison of spectral estimates at input and non-input frequencies provides an indication of the reliability of the describing function estimate.

SOS techniques can yield reliable performance estimates over a relatively wide

frequency bandwidth for idealized laboratory tasks in which a high bandwidth system is controlled and in which the operator is paying close attention to the tracking task [1]. Measurement bandwidth may be seriously reduced, however, when the tracking dynamics contain significant lags or delays [2]; when the operator is involved in an operational task, or in a realistic simulation thereof, requiring attention to tasks other than continuous control [3]; or when measurements are made of inherently "noisy" physiologic response mechanisms such as evoked electrocortical response [4,5]. In these situations ensemble averaging procedures are required to maximize the bandwidth over which reliable performance estimates can be obtained.

The purpose of this article is to suggest a particular method for computing the average operator describing function from an ensemble of experimental trials, and for estimating the reliability of the ensemble mean, in both open-loop and closed-loop measurement environments. Compared to analysis methods used in the recent past by this author and others, the methods suggested here are expected to increase the bandwidth over which reliable performance measures can be obtained.

The method suggested here makes use of trial-to-trial variations in the describing function to determine the reliability of the describing function estimates. This method, of course, requires that a number of experimental replicates be obtained. If there are only a few replicates -- or only a single trial -- reliability must be determined from remnant measurements as outlined above.

The following discussion is confined to experiments using SOS inputs. The reader is directed to two review articles [6,7] for a more detailed discussion of SOS analysis techniques, and for a comparison of SOS with alternative techniques for identifying operator response parameters.

CURRENT PRACTICE

Given sufficient time for transients to damp out, a noise-free linear system driven by a sum-of-sines (SOS) input will respond only at frequencies contained in the forcing function. Describing function estimates, therefore, are obtained only at input (i.e., SOS) frequencies. Conversely, system response power at non-input frequencies is defined as "remnant".

Experimental data are usually digitized for either online or offline analysis by digital computer. The resultant time histories, then, are sampled, and analysis techniques appropriate to sampled data are employed. Discrete Fourier transform (DFT) techniques are employed to compute Fourier coefficients of relevant time histories, and to compute estimates of power spectra (actually, squared magnitudes of Fourier coefficients).

The following procedure has often been used to estimate human operator describing functions and remnant:

1. By means of the DFT, compute Fourier coefficients for the time histories representing the operator's input (e.g., tracking error) and output (e.g., control response).
2. At each SOS frequency, compute the estimate of the operator's describing function as the (complex) ratio H of the Fourier coefficient of the output signal to the Fourier coefficient of the input signal. Express this estimate in terms of "gain" and "phase shift", where

$$\text{Gain} = 10 \log (|H|^2) \text{ dB}$$

$$\text{Phase} = 57.3 \tan^{-1} (\text{Im}\{H\}/\text{Re}\{H\}) \text{ degrees}$$

3. Compute the "spectra" for the input and output signals as the magnitude-squared of the Fourier coefficients.
4. For both the input and output signals, compute the average remnant power in a small frequency band about each SOS frequency. Assume the remnant power varies smoothly with frequency, and consider this average power to be an estimate of the remnant power at the corresponding SOS frequency.
5. Compute signal-to-noise (S/N) ratios for both signals by dividing the power actually measured at a given SOS frequency by the estimated remnant power at that frequency. If the S/N ratios for both input and response signals are above some criterion level (typically, 6 or 7 dB) at a given SOS frequency, consider the corresponding describing function estimate computed in Step 2 to be valid. If the S/N for either the input or the output signal falls below the criterion, we conclude that a valid describing function cannot be obtained at that particular frequency.

The above procedure is a reasonable one to follow when considering a single experimental trial, as it prevents the acceptance of a describing function estimate that is likely to be seriously corrupted by operator remnant. When performing experiments with human test subjects, however, we generally attempt to improve measurement reliability by ensemble-averaging the results from a number of replications of a given test condition.

To compute ensemble statistics of the operator describing function, we first compute the describing function (in terms of gain and phase) for each experimental trial, retaining only those measurements considered valid by the signal-to-noise test. Using only these valid measurements, we then compute the mean and standard deviation of the gain, and the mean and standard deviation of the phase shift at each SOS frequency.

While this method is straightforward, it is deficient in a number of respects. First, it tends to be pessimistic in that it tests the reliability of each individual measurement rather than of the ensemble mean. As a result, certain measures are unnecessarily discarded. Second, it may yield a frequency response curve that has an inconsistent data base. That is, measurements will be retained from all experimental trials at frequencies where remnant is relatively small, whereas measures from only a subset of trials will generally be retained at frequencies where remnant is significant. Finally, this method tends to overestimate the mean gain, because it retains measurements where remnant power has tended to reinforce the input-correlation portion of the response, and it discards measurements where remnant has tended to counteract the input correlated component.

The analysis methodology described in the remainder of this document circumvents these particular difficulties by using all the available data to compute the ensemble mean, and then directly estimating the reliability of the mean. Thus, one retains or rejects all the describing function data at a given SOS frequency.

KEY ASSUMPTIONS AND RELATIONSHIPS

Before proceeding with the development of the describing function analysis techniques, we first make certain assumptions concerning the nature of operator remnant, and we then present certain mathematical results that are used in the subsequent development.

Remnant

The following discussion concerns Fourier coefficients of the remnant processes as might be determined by a DFT. In general, a number of experimental trials are analyzed and, for each trial and each signal analyzed, remnant coefficients are computed at each DFT frequency.

In general, a remnant-related DFT coefficient will be a complex number. Let

$$R_{i,k} = X_{i,k} + jY_{i,k}$$

Where R is a complex quantity having real part X and imaginary part Y , and "i" and "k" are the frequency and ensemble (i.e., experimental replication) indices, respectively.

The following key assumptions are made concerning the remnant process:

Assumption 1: Remnant is linearly uncorrelated with external signals and system functions.

Assumption 2: The Fourier coefficients are zero-mean Gaussian variables. Thus

$$\varepsilon\{X_{i,k}\} = \varepsilon\{Y_{i,k}\} = 0$$

where ε is the expectation operator.

Assumption 3): The real and imaginary components of R are linearly uncorrelated across frequency and across replications: Thus,

$$\varepsilon\{X_{i,k} \cdot Y_{j,\ell}\} = 0 \quad \text{all } i, j, k, \ell$$

Assumption 4: The autocovariance of the real part is equal to the autocovariance of the imaginary part. The real and imaginary parts of the Fourier coefficient are otherwise uncorrelated across frequencies and across replications. Thus

$$\begin{aligned} \varepsilon\{X_{i,k} \cdot X_{j,\ell}\} &= \varepsilon\{Y_{i,k} \cdot Y_{j,\ell}\} \\ &= \begin{cases} 0 & i \neq j \text{ or } k \neq \ell \\ \sigma_r^2 & i = j \text{ and } k = \ell \end{cases} \end{aligned}$$

where

$$\begin{aligned} \sigma_r^2 &= \varepsilon\{|R_{i,k}|^2\} \\ &= \varepsilon\{X_{i,k}^2\} + \varepsilon\{Y_{i,k}^2\} \end{aligned}$$

Assumption 5: The remnant process is a smoothly-varying function of frequency. The spectrum contains no "spikes" or "holes", and the power density spectrum may be considered locally stationary over any sufficiently narrow frequency band. Expressed mathematically,

$$\varepsilon\{X_{i,k}^2\} = \varepsilon\{X_{j,\ell}^2\}$$

for all values of k and ℓ and for i "close" to j .

In summary, the remnant is assumed to be a zero-mean Gaussian process whose real and imaginary coefficients have zero cross-correlation, zero covariance across frequency and replication, and equal autocovariance. We shall refer to this process as a "stationary incoherent" process, as it implies that remnant power is statistically constant, whereas phasing is randomly distributed between 0 and 2π across frequencies and across replications.

Other than for local stationarity, we make no assumptions concerning the frequency shaping of the remnant process. In general, the remnant process will be non-white, and the frequency dependency will depend on the internal state of the operator and on the external task environment.

Key Relationships

The following key relationships, which follow from the assumptions stated above and from the properties of linear systems, form the basis of the error analysis to follow.

1. Linear Transformation of the Remnant

A Fourier coefficient obtained by transforming the remnant coefficient by a linear system is a stationary incoherent variable. Thus if

$$F = AR = X_f + jY_f$$

where A is the system function (at a given frequency) of some linear process, then

$$\varepsilon\{X_f^2\} = \varepsilon\{Y_f^2\} = |A|^2 \frac{\sigma_r^2}{2}$$

and

$$\varepsilon\{|F|^2\} = |A|^2 \sigma_r^2$$

2. Effects of Averaging

The Fourier coefficient obtained by averaging multiple samples of linearly transformed remnant is a stationary incoherent variable, with variance reduced by the number of samples. Let

$$\begin{aligned}\bar{F} &= \frac{1}{N} \sum_{n=1}^N F = \frac{1}{N} \sum_{n=1}^N AR \\ &= X_{\bar{f}} + jY_{\bar{f}}\end{aligned}$$

then

$$\varepsilon\{X_{\bar{f}}^2\} = \varepsilon\{Y_{\bar{f}}^2\} = \frac{|A|^2}{N} \cdot \frac{\sigma_r^2}{2}$$

and

$$\varepsilon\{|\bar{F}|^2\} = \frac{|A|^2}{N} \sigma_r^2$$

3. Error Analysis of Gain and Phase Estimates

Let

$$H = H_o(1+R')$$

where H is the describing function (or average describing function) measured in some experiment, H_o is the "true" describing function that one wishes to estimate, and R' is a stationary incoherent noise process (typically, the operator's remnant R linearly transformed and averaged), such that

$$\epsilon\{|R'|^2\} = \sigma_{R'}^2,$$

We define the operations of computing gain and phase as follows:

$$G(H) \equiv 10 \cdot \text{Log}(|H|^2) \quad \text{dB}$$

$$\phi(H) = 57.3 \tan^{-1}(\text{Im}\{H\}/\text{Re}\{H\}) \quad \text{degrees}$$

If $\sigma_{R'}^2 \ll 1$, the following approximations (see the Appendix) may be used for estimating the gain and phase and their standard errors:

$$\hat{G}_o \simeq G(\hat{H}_o)$$

$$\hat{\phi}_o \simeq \phi(\hat{H}_o)$$

$$\sigma_{\hat{G}} \simeq 6.14 \sigma_{R'}$$

$$\sigma_{\hat{\phi}_o} \simeq 40.5 \sigma_{R'} = 6.60 \sigma_{\hat{G}}$$

where the symbols " $\hat{\quad}$ " and " $\tilde{\quad}$ " signify estimation and estimation error, respectively. Note that a fixed relationship obtains between the estimation errors (i.e., standard error) for gain and phase.¹

¹The number 6.14 is a three-digit approximation to $\sqrt{2 \cdot 10 \cdot \log(e)}$; the number 40.5 is an approximation to $(180/\pi)/\sqrt{2}$.

ANALYSIS OF OPEN-LOOP SYSTEMS

We define an "open-loop" measurement environment as one in which the system to be investigated is driven by an external forcing function whose characteristics can be controlled and measured exactly. With respect to human operator response, the measurement of a physiologic response such as a visually-evoked electrocortical response [4] falls into this category. A block diagram of such a system is given in Figure 1, where E represents the Fourier coefficient of the external input (or "error"), C the Fourier coefficient of the system response, H the linear system function to be estimated, and R the Fourier coefficient of the remnant added to the linear portion of the system response. The goal of analysis procedure is to estimate the gain and phase shift of the describing function H, and to estimate the associated standard errors.

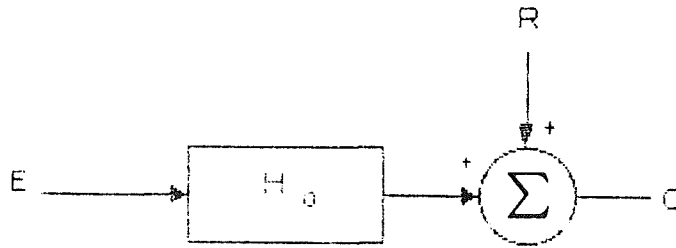

Figure 1: Block Diagram of the Open-Loop Measurement Situation

At non-SOS frequencies, the response C will consist simply of remnant. At SOS frequencies, the response will consist of the sum of remnant plus an input-correlated component. Thus, at input frequencies;

$$C = H_0 E + R$$

We assume that E is statistically stationary for a given SOS frequency. That is

$$|E_n|^2 = E$$

for all n. In general, however, the phasing of E will vary from trial-to-trial.

Let H_n be the describing function (a complex number) measured on the n_{th} experimental trial for some SOS frequency. Thus

$$H_n \equiv \frac{C_n}{E_n} = H_0 + \frac{R_n}{E_n}$$

The describing function may be expressed equivalently as

$$H_n = H_0 + \tilde{H} = H_0(1 + \tilde{H}/H_0)$$

where $\tilde{H} = R/E$. Since R is (by assumption) an incoherent random process, H_0 is (by assumption) a constant, and E is (by design) a complex number having a fixed magnitude, the processes \tilde{H} and \tilde{H}/H_0 are also stationary incoherent processes.

Because we are considering stationary incoherent process, statistics of the complex variable \tilde{H}/H_0 may be computed the same way one would compute statistics for a Gaussian random variable. Specifically, an unbiased estimate of the population mean is the experimental sample mean, and an unbiased estimate of the population variance may be computed as the ensemble sum of the magnitude-squared, minus the sum of squared magnitude of the experimental mean, divided by the number of samples minus one. Thus

$$\begin{aligned} \hat{H}_0 &= \bar{H} \\ \sigma_{\tilde{H}/H}^2 &= \frac{1}{|H_0|^2} \cdot \frac{1}{N-1} \cdot \left[\sum |H|^2 - \sum |\bar{H}|^2 \right] \\ &= \frac{1}{|H_0|^2} \frac{N}{N-1} \left[\overline{|H|^2} - |\bar{H}|^2 \right] \end{aligned}$$

where \bar{H} is the empirical average of H over the N experimental trials and $\overline{|H|^2}$ is the average squared magnitude.

Since the averaging process reduces the variances by $1/N$, the estimated variance of the error in the mean describing function (i.e., the standard error) is

$$\sigma_{\tilde{H}/H_0}^2 = \frac{1}{N-1} \left[\frac{\overline{|H|^2}}{|\bar{H}|^2} - 1 \right]$$

where $|\bar{H}|^2$ is taken as an estimate of $|H_0|^2$.

If we define $\sigma_{\tilde{H}/H_0}^2$ as σ_r^2 , then, from the relationships of (1) developed earlier, we obtain the following expressions for the estimated mean gain and phase, and associated standard errors:

$$\begin{aligned} \hat{G}_O &= G(\bar{H}) \\ \hat{\phi}_O &= \phi(\bar{H}) \\ \sigma_{\tilde{G}} &= 6.14 \left[\frac{1}{N-1} \left(\frac{|\bar{H}|^2}{|\bar{H}|^2} - 1 \right) \right]^{1/2} \\ \sigma_{\tilde{\phi}} &= 6.60 \sigma_{\tilde{G}} \end{aligned}$$

Since the mean-squared value of a quantity is never less than the square of the sample mean, the expression for $\sigma_{\tilde{G}}$ is guaranteed to be mathematically well-behaved in that the quantity to be square-rooted is always non-negative.

In the case where one has a sufficient number of experimental replications (say, more than four), the following procedure is recommended for estimation of describing functions at each SOS frequency:

1. Compute the describing function for each replicate.
2. Average the describing function measurements (as complex coefficients) across trials.
3. Compute the estimated gain and phase shift from the average (complex) describing function.
4. Estimate the standard errors of the gain and phase estimates from the relationships given above.
5. Accept the gain and phase estimates as "valid" if the standard error for gain is below some criterion level (say, 2 or 3 dB); otherwise, reject the estimates as "invalid".

There are two reasons for testing the estimated standard error against some criterion for validity. First, a large standard error would tend to render the estimated gain and phase of minimal usefulness for further analysis (such as averaging with the results of other test subjects, or for performing model analysis). Second, the procedures given here for estimating standard errors are valid only if these errors are relatively small. Thus, if we compute a relatively large standard error, we are in doubt not only about the mean gain and phase, but we are also unsure of the reliability of these estimates.

ANALYSIS OF CLOSED-LOOP SYSTEMS

A closed-loop system is defined diagrammatically in Figure 2. In this situation, the input E to the system of interest is not an independent variable, but a linear function of an external SOS input I and the system response C. Again, the operator's response

is assumed to contain a component linearly related to his input, plus a remnant component. A minus sign is associated with H_o in Figure 2 to conform to the conventions used when analyzing systems with negative feedback.

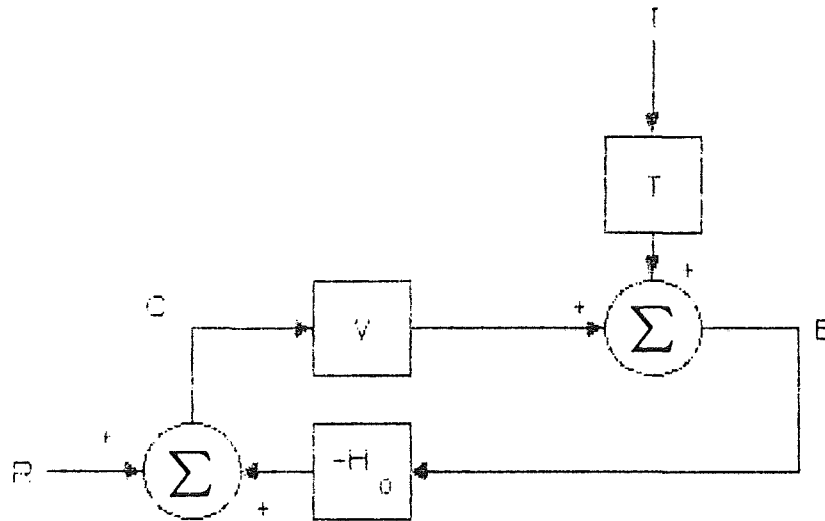

Figure 2: Block Diagram of the Closed-Loop Measurement Situation

The transfer function T is included in the system diagram to allow general treatment of the external SOS forcing function I . For example, T is unity when I is a simple command or target input, whereas T is equivalent to the vehicle transfer function V when the input is added directly to the operator's control response. On the other hand, if the system to be analyzed consists of a simulated flight task with gusts interacting in an aerodynamically realistic fashion, the transfer function T will be neither V nor unity.

Again, the measurement goal is to obtain an estimate of the operator's describing function H_o , expressed in terms of gain and phase, and to estimate the associated standard errors. The situation is complicated, however, by the fact that the input to the operator is not an independent variable under the complete control of the experimenter, but is determined in part by the closed-loop system response and is therefore corrupted by operator remnant.

From Figure 2 we derive the following relationships between the "error" and "control" signals (i.e., input and output to the human operator) and the independent forcing function:

$$E = \frac{T}{\Delta} I + \frac{V}{\Delta} R$$

$$C = -\frac{H_o T}{\Delta} I + \frac{1}{\Delta} R$$

where

$$\Delta = 1 + H_o V$$

If we were to compute the operator's describing function from a single experimental trial, we would obtain

$$H = -\frac{C}{E} = H_0 \frac{1 - \frac{R}{H_0 T I}}{1 + \frac{V R}{T I}}$$

Because remnant appears in both the denominator and numerator terms, ensemble-averaging the describing function estimates computed in this manner will not necessarily reduce the measurement error due to remnant. In the case of sufficiently large remnant, the describing function computed as shown above will be approximately the negative inverse of the vehicle dynamics -- not the desired quantity H_0 -- no matter how many replications are averaged.

An alternative approach is to perform the averaging process before performing the division. This can be accomplished by using the following average cross-power coefficients:

$$\begin{aligned} \overline{EI}^* &= \frac{T}{\Delta} |I|^2 + \frac{V}{\Delta} \overline{RI}^* \\ \overline{CI}^* &= -\frac{H_0 T}{\Delta} |I|^2 + \frac{1}{\Delta} \overline{RI}^* \end{aligned}$$

where the overstrike represents an average computed over N experimental replications. As the input power is assumed to be stationary across replicates, average input power is equal to the input power at any replicate (for a given SOS frequency).

We now compute the average (complex) transfer function from the average cross-spectral components as:

$$\hat{H}_0 = \frac{\overline{CI}^*}{\overline{EI}^*} = H_0 \frac{1 - \frac{\overline{RI}^*}{H_0 T |I|^2}}{1 + \frac{V \overline{RI}^*}{T |I|^2}}$$

The expression for the estimated transfer no longer contains the "raw" remnant signal, but rather the average of the cross-correlation of the remnant with the external forcing function. Because the remnant is, by definition, theoretically uncorrelated with the forcing function, the error due to remnant will tend toward zero

as the number of replicates increases, even when the remnant power is relatively large.

The following effective "remnant variance", derived in the appendix, is needed for estimating standard errors:

$$\sigma_{r'}^2 = \frac{1}{(N-1)} \left[\frac{\overline{|CI^*|^2}}{\overline{|CI^*|}^2} + \frac{\overline{|EI^*|^2}}{\overline{|EI^*|}^2} - 2 \cdot \text{Re} \left\{ \frac{\overline{(CI^*)(EI^*)^*}}{\overline{(CI^*) \cdot (EI^*)^*}} \right\} \right]$$

where averaging operations are performed across an ensemble of N experimental trials. The third term in the above expression accounts for the linear correlation (through the vehicle dynamics) between the remnant-related components of the error and control signals. The variance term σ_r^2 , is guaranteed to be non-negative. The square root of the above quantity is used to compute the following standard errors:

$$\begin{aligned} \sigma_G^{\sim} &= 6.14 \sigma_r, & \text{dB} \\ \sigma_{\phi}^{\sim} &= 40.5 \sigma_r, = 6.60 \sigma_G^{\sim} & \text{degrees} \end{aligned}$$

The following procedure is recommended for estimating operator describing functions obtained from a closed-loop control environment:

1. For a given SOS frequency, compute the cross-power coefficients CI^* and EI^* , and the magnitude-squared of these complex coefficients, for each experimental trial in the ensemble.
2. Average the cross-power coefficients across the ensemble, and compute the average (complex) transfer function as $-\overline{CI^*}/\overline{EI^*}$.
3. Compute the gain and phase from the average describing function computed in Step 2.
4. Estimate the standard errors of the gain and phase estimates as shown above.
5. Discard measurements for which the standard error of the gain exceeds some allowable maximum level.

DISCUSSION

Modifications to current methods for estimating human operator describing functions have been suggested. Although the techniques proposed here are similar to those employed when inputs are continuous in frequency, they are not generally employed when sum-of-sinusoids inputs are used.

The key assumption underlying the method is that operator remnant is a "stationary incoherent" process -- that is, a zero-mean Gaussian process whose real and imaginary DFT coefficients have zero cross-correlation, zero covariance across frequency and experimental replication, and equal autocovariance at a given frequency. With this assumption, along with the known properties of linear systems, we can compute approximations to the estimation errors for both gain and phase shift.

Some of the key features of the method are:

1. Statistics are performed on Fourier coefficients or ratios of Fourier coefficients; these statistics are then transformed to the amplitude ratio ("gain") and phase-shift domain.
2. For closed-loop systems, the estimated average describing function is computed as the ratio of the (a) ensemble-averaged cross-power spectral densities between input and control response, and (b) the cross-power density between input and error. Describing function estimates are not directly computed for individual trials. For open-loop systems, however, the average describing function is computed by averaging the describing function computations for individual trials.
3. The standard errors of the average gain and phase estimates are computed as transforms of the standard errors of Fourier coefficients; they are not computed by first determining the standard deviations of gain and phase and then normalizing by the square root of the number of trials.
4. Data from all experimental trials are used in computing the describing function statistics. Reliability criteria are applied to the resulting averages, not to individual describing function estimates.
5. The standard error associated with the phase-shift estimate at a given measurement frequency is related by a known constant to the standard error of the corresponding gain estimate.

The assumption behind this proposed technique is that one is interested primarily in analyzing a given subject's average behavior. This is usually the case when subjects have been trained to asymptotic behavior, or where model analysis is to be performed. In this case, the reliability of the experimental mean (i.e., the "standard error") is of direct concern, not the reliability of measurements that might be obtained in individual experimental trials.

If trial-to-trial variations are of interest, however, as might be the case in studies of training effectiveness, it may be necessary to estimate operator performance on single experimental trials, using remnant-based methods for determining measurement reliability.

The derivation of the methods presented here were motivated by difficulties in obtaining reliable estimates of describing functions for physiologic systems and for pilot response behavior in simulations of operational situations. The method has recently been used to analyze visual evoked electrocortical responses, [4,5], and is contemplated for application to data obtained from a simulated air-combat tracking task [7].

REFERENCES

1. Levison, W.H., "Measurement of Human Operator Response Behavior", Report No. 4307, Bolt Beranek and Newman Inc., Cambridge, MA, February 1980.
2. Levison, W.H., "The Effects of Display Gain and Signal Bandwidth on Human Controller Remnant," AMRL-TR-70-93, Aerospace Medical Research Laboratory, Wright-Patterson Air Force Base, Ohio, March 1971.
3. Levison, W.H., Muralidharan, R., "Analysis of Manual Control Tasks in Support of the Chemical Defense Program", Report No. 5168, Bolt Beranek and Newman Inc., Cambridge, MA, December 1982.
4. Junker, A.M., Kenner, K.M., Kleinman, D.L., McClurg, T.D., "Comparison of Steady-State and Transient Visual Evoked Response Potential", Twenty-First Annual Conference on Manual Control, June 17-19, Ohio State University, Columbus, Ohio.
5. Levison, W.H., Junker, A.M., Kenner, K.M., "Descriptive Linear Modelling of Steady-State Visual Evoked Response", Twenty-First Annual Conference on Manual Control, June 17-19, Ohio State University, Columbus, Ohio.
6. Levison, W.H., "Methods for Identifying Pilot Dynamics", in Frazier, M.L., and Crombie, R.B., (eds): Proceedings of the Workshop on Flight Testing to Identify Pilot Workload and Pilot Dynamics, AFFTC-TR-82-5, Air Force Flight Test Center, Edwards Air Force Base, CA, May 1982.
7. "F-14 Modelling Study", NASA Langley Research Center, Contract No. NAS1-17648.

ACKNOWLEDGEMENT

The analysis summarized in this document was supported in part by the Air Force under Contract Number F33615-84-C-0515, and in part by the NASA Langley Research Center under Contract No. NAS1-17648.

APPENDIX

Error Analysis for Closed-Loop Describing Function

In the main text we developed the following expression for estimating describing functions in closed-loop control tasks:

$$\hat{H}_O = \frac{\overline{CI^*}}{\overline{EI^*}}$$

where H is the estimated describing function at a given input frequency; I, E, and C are the complex Fourier coefficients of the input, error, and control signals, respectively;

and the overstrike indicates ensemble averaging across experimental replications. Note that the average cross-power products are obtained before the ratio is taken.

It is convenient to represent the computed average describing function as

$$\bar{H} = H_0 (1 + r')$$

where H is the "theoretical" or "true" describing function (i.e., the describing function one would measure if the operator were totally linear, noise-free, and consistent), and r' is the deviation of the empirical average from this value. In the following development we derive the variance (expected squared magnitude) of the complex quantity r' .

To simplify the notation, we define the following quantities:

$$C' \equiv \overline{CI^*}$$

$$E' \equiv \overline{EI^*}$$

We now write the average cross-power spectral quantities as

$$C' = C'_0 + \tilde{C}'$$

$$E' = E'_0 + \tilde{E}'$$

The average describing function may then be represented as

$$\bar{H} = \frac{C'_0 + \tilde{C}'}{E'_0 + \tilde{E}'} = H_0 \frac{1 + \tilde{C}/C'_0}{1 + \tilde{E}/E'_0}$$

If we assume that $\tilde{E}/E'_0 \ll 1$, the above expression may be approximated as:

$$\bar{H} \approx E_0 \left(1 + \tilde{C}' / C'_0 - \tilde{E}' / E'_0 \right)$$

The "measurement error" term r' is thus identified as

$$r' \approx \tilde{C}' / C'_0 - \tilde{E}' / E'_0$$

Because the quantities \tilde{E}' and \tilde{C}' are, by assumption, "stationary incoherent" processes as defined in the main text, the error term r' is also a stationary incoherent process.

We cannot measure the error quantities \tilde{C} and \tilde{E} . In order to work with quantities that can be measured (or estimated from measured quantities), we use the relationships

$$\begin{aligned} \tilde{E}' &= E' - E'_0 \\ \tilde{C}' &= C' - C'_0 \end{aligned}$$

to derive the following equivalent expression for the error term:

$$\begin{aligned} r' &= \frac{C' - C'_0}{C_0} - \frac{E' - E'_0}{E_0} \\ &= \left(\frac{C'}{C_0} - 1 \right) - \left(\frac{E'}{E_0} - 1 \right) = \frac{C'}{C_0} - \frac{E'}{E_0} \end{aligned}$$

The expected magnitude-squared of the error term is thus computed as

$$\hat{\sigma}_{r'}^2 = \frac{N}{N-1} \left[\frac{|C'|^2}{|C'_0|^2} + \frac{|E'|^2}{|E'_0|^2} - 2 \cdot \operatorname{Re} \left\{ \frac{C' E'^*}{C'_0 E'_0^*} \right\} \right]$$

In terms of the cross-power quantities computed from the experimental data, the above expression may be written as

$$\hat{\sigma}_{r'}^2 = \frac{1}{N-1} \left[\frac{|CI^*|^2}{|\overline{CI^*}|^2} + \frac{|EI^*|^2}{|\overline{EI^*}|^2} - 2 \cdot \operatorname{Re} \left\{ \frac{(CI^*) (EI^*)^*}{(\overline{CI^*}) \cdot (\overline{EI^*})^*} \right\} \right]$$

Note that the factor "N" has been dropped from the numerator, because the variance of interest is the standard error of the mean, not the trial-to-trial standard deviation. Also, the empirical calculation of $|\overline{CI^*}|^2$ is used for $|C'_0|^2$, etc.

Transformation from Complex to Gain/Phase Domain

The methodology presented in this paper requires that statistics of the describing function measures (mean and standard error of the mean) be obtained in the complex-number domain, then transformed into the gain/phase domain. This transformation is derived below.

Let the estimated average describing function (complex quantity) be expressed as

$$\overline{H} = H_0 (1 + r')$$

where H is the "true" describing function and r' is a stationary incoherent error term having a variance as derived above. Let X and Y represent the imaginary parts of r; the above expression may be written as:

$$\bar{H} = H_0 (1 + X + jY)$$

Gain Computation

The gain G is defined as

$$\begin{aligned} G &= 10 \text{ Log } (|H|^2) = 4.34 \text{ Ln } (|H|^2) \\ &= G_0 + G_e \end{aligned}$$

where

$$\begin{aligned} G_0 &= 10 \text{ Log } (H_0) \\ G_e &= 4.34 \text{ Ln } (1 + 2X + X^2 + Y^2) \end{aligned}$$

We note that the natural logarithm of $(1+z)$ may be expressed by the series $z - z^2/2 + z^3/3 - (\text{etc.})$. If X and Y are Gaussian variables or otherwise have symmetric statistics, expected value of odd powers are zero. If, in addition, the magnitude of the error term is small compared to unity, we may ignore powers greater than 2 when computing expected values. Thus,

$$G_e \approx 2X + Y^2 - X^2$$

Since X and Y are assumed equi-variant, the mean of the error term is negligibly different from zero. Therefore, performing the "gain operation" on the magnitude of the average describing function yields an unbiased estimate of the gain of the "true" describing function.

If we drop terms higher than second-order, the variance (expected mean-squared magnitude) of the error term is approximately

$$\sigma_{G_e}^2 \approx (4.34)^2 \epsilon \{4 X^2\}$$

Noting that the expected value of X is half the expected magnitude-squared of the variable r', we obtain

$$\sigma_G^2 = 2 (4.34)^2 \sigma_{r'}^2$$

and

$$\sigma_G = 6.14 \sigma_{r'} \text{ dB}$$

Phase Computation

The phase shift of H may be expressed as

$$\phi = \phi_0 + \phi_e$$

where

$$\phi_e = \tan^{-1} \left[\frac{Y}{1+X} \right]$$

If we assume $X, Y \ll 1$, the phase shift of the error term is approximately

$$\phi_e \approx Y (1 - X + X^2)$$

Because X and Y are assumed to be linearly uncorrelated, the expected mean error is zero. Thus, performing the "phase operation" on the average describing function yields an unbiased estimate of the average phase shift. If we square the error term, ignore terms higher than second order, and take the expected value (recalling that X and Y are equi-variate), we obtain

$$\begin{aligned} \sigma_{\phi}^2 &= \sigma_{r'}^2 / 2 && \text{rad}^2 \\ &= (57.3)^2 \sigma_{r'}^2 / 2 && \text{deg}^2 \\ \text{and} \\ \sigma_{\phi} &= 40.5 \sigma_{r'} && \text{deg} \end{aligned}$$

Note that the standard error of the phase bears a fixed relationship to the standard error of the gain.