

N 86-33009

Modified Superposition: A Simple  
Time Series Approach to Closed-Loop Manual  
Controller Identification

Daniel J. Biezad, Lt. Col, USAF  
Professor David K. Schmidt  
Mr. Frank Leban  
Susan Mashiko, Capt. USAF

Purdue University  
School of Aeronautics and Astronautics  
West Lafayette, Indiana 47907

Air Force Institute of Technology  
Department of Electrical and Computer Engineering  
Wright-Patterson AFB, Ohio 45433

ABSTRACT

Single-channel "pilot" manual control output in closed-tracking tasks is modeled in terms of linear discrete transfer functions which are parsimonious and guaranteed stable. The transfer functions are found by applying a modified superposition time series generation technique. A Levinson-Durbin algorithm is used to determine the filter which prewhitens the input and a projective (least squares) fit of pulse response estimates is used to guarantee identified model stability. Results from two case studies are compared to previous findings, where the source of data are relatively short data records, approximately 25 seconds long. Time delay effects and pilot seasonalities are discussed and analyzed. It is concluded that single-channel time series controller modeling is feasible on short records, and that it is important for the analyst to determine a criterion for "best time domain fit" which allows association of model parameter values, such as pure time delay, with actual physical and physiological constraints. The "purpose" of the modeling is thus paramount.

SHORT TITLE: AUTOREGRESSIVE PILOT MODELS

KEY WORDS:

pilot modeling  
autoregressive process  
closed loop system identification  
prewhitening  
superposition  
single input, single output  
manual control

NOMENCLATURE

$a(z)$  numerator discrete polynomial in  $z$   
 $a_k$  coefficient of  $z^{-k}$  in  $a(z)$   
 $b(z)$  denominator discrete polynomial in  $z$   
 $b_k$  coefficient of  $z^{-k}$  in  $b(z)$   
 $g_p(z)$  discrete pilot model pulse response  
 $e(t)$  error displayed to pilot at instant  $t$   
 $g_k$  coefficient of  $z^{-k}$  in  $g(z)$   
 $G_p(z)$  pilot transfer function as a ratio of polynomials  
i.i.d. independent, identically distributed  
 $k$  lag implying " $k\Delta$ " seconds  
 $K_p$  pilot gain expressed in degrees per degree  
 $N$  total points available  
 $R(t)$  pilot input uncorrelated with  $y(t)$  in degrees at instant  $t$   
 $w(t), v(t)$  white noise sequence (i.i.d.) at instant  $t$   
 $y(t)$  controlled element output signal in degrees pitch angle at instant  $t$   
 $\Delta$  sample interval (seconds)  
 $\delta(t)$  pilot output in degrees of elevator deflection at instant  $t$   
 $\tau$  number of sample times in pure time delay  
 $\nu$  transformed frequency  
 $\omega$  frequency  
 $\Omega(z)$  prewhitening filter in  $z$

## 1. INTRODUCTION

The key question of how the human being will be inserted in the control loop of complex processes remains an issue throughout our society (Rosenbrock, 1983), but nowhere is it more urgent than in flight control systems design and analysis (Harper, 1983). The fact that a pilot of a modern aircraft is becoming a sophisticated systems monitor (Rouse, 1983) in no way implies his demise as a controller (Rouse, 1980; Sheridan, 1974), and a fundamental assumption in this work is that the interaction between man and machine should be understood much better than it is today (Palmer, 1983).

Although describing function (McRuer, 1965) and optimal control (Kleinman, 1969-1974) pilot models have been ingeniously used to provide insight into piloting strategy (Schmidt, 1979; Bacon, 1983; Hess, 1977), they are now supplemented with pilot models derived from the emerging field of time series analysis. Time series modeling of pilot behavior offers tremendous potential for discerning key system characteristics and relationships, such as the actual effect of instabilities (Goto, 1974), pilot stress (Shinners, 1974), or task effects (Agarwal, 1980).

The key questions in time series models involve not only the parsimony of parameters, well established by Breddermann et al (1978), but of identified model stability and the model's practical application in analysis (Baron, 1980). Shinner (1974) seriously discussed the closed-loop identification problem, but the manipulation of transfer functions in his fitting procedure contains no guarantee of final model stability. The primary purpose of this work is to present a theoretically sound and relatively simple closed-loop fitting procedure, still based firmly in the common sense methods of Box and Jenkins (1976), which guarantees model stability without sacrificing model accuracy.

## 2. MODEL

The linear discrete closed-loop model structure is shown in Figure 1. Each block represents a discrete pulse response sequence which, when convolved with the discrete input sequence, yields the discrete output sequence. Stable pulse sequences, even though infinite in durations, eventually must decay for a stable system. When the pulse sequence is expressed as a ratio of polynomials, stability is guaranteed if the denominator roots are less in magnitude than one. The goal

is to identify the pulse response sequence  $g_p(z)$  and approximate its discrete (z domain) transfer function from actual data sets  $\{\delta(t)\}$ ,  $\{y(t)\}$ , and  $\{W(t)\}$  which are equispaced in time with their means removed.

The assumptions are model linearity, time invariance, causality, uncorrelated inputs  $W(t)$  and  $R(t)$ , and prewhitenable input  $W(t)$ ; that is,  $W(t)$  is a linear function of previous values plus a white noise "shock." Previous values are mathematically linked by the backward shift operator  $z^{-1}$ .

### 3. MODIFIED SUPERPOSITION TECHNIQUE

First, every signal in Figure 1 is decomposed conceptually into a part linearly correlated with command disturbance  $W(t)$ , the remainder uncorrelated with  $W(t)$ . For example, output  $y(t)$  is the sum of  $Y_L(t)$ , which is correlated with  $W(t)$ , and of  $Y_R(t)$ , considered the effect of an additional unknown input  $R(t)$ , termed "Remnant," uncorrelated with  $W(t)$ . The pulse response to be found relates, for constant sampling interval " $\Delta$ " seconds, the linearly correlated pilot output  $\delta_L(t)$  to the correlated error signal  $e_L(t)$ ; that is,

$$e_L(z)g_p(z) = \delta_L(z) \quad (1)$$

This pulse response may be expressed as an infinite sequence or as a ratio of polynomials:

$$G_p(z) \triangleq Kz^{-\tau}a(z)/b(z) \triangleq z^{-\tau} \left( \sum_{k=0}^{\infty} g_k z^{-k} \right) \quad (2)$$

where

$$a(z) = \left( 1 + \sum_{k=1}^{k=l} a_k z^{-k} \right) \quad (3)$$

$$b(z) = \left( 1 + \sum_{k=1}^{k=s} b_k z^{-k} \right) \quad (4)$$

and  $s \geq l$  imposed constraint

If the integer "k" in Equation (2) is allowed all values ( $-\infty < k < +\infty$ ), then Equation (2) defines the discrete transfer function relating the z-transform of input sequence  $e_L(t)$  to the z-transform of output sequence  $\delta_L(t)$  (Franklin and Powell, 1980, p.15).

Although the signals  $\delta_L(t)$  and  $e_L(t)$  are not directly available, they must be "generated" if loop closure effects are properly taken into account. To do this apply superposition to signals  $Y(t)$  and  $W(t)$  of Figure 1:

$$Y(t) = G_1(z)W(t) + G_2(z)R(t) \quad (5)$$

$$Y_L(t) \triangleq G_1(z)W(t) \quad (6)$$

where

$$G_2(z) = -G_a(z)/[1-G_a(z)G_p(z)] \quad (7)$$

$$G_1(z) = G_p(z)G_2(z) \quad (8)$$

Since  $W(t)$  is prewhitenable (defined above) and uncorrelated with  $R(t)$  the cross correlation identification technique of Box and Jenkins (details in Appendix) may be applied to find an estimate of the initial portion of the pulse response sequence  $g_1(z)$ , between  $y(t)$  and  $W(t)$ . Then  $a_1(z)$  and  $b_1(z)$  may be determined as shown in the section on model stability, such that

$$G_1(z) = a_1(z)/b_1(z) \quad (9)$$

The essence of modified superposition is now to generate the time series  $Y_L(t)$  using the autoregressive relation

$$b_1(z)Y_L(t) = a_1(z)W(t) \quad (10)$$

Where  $a_1(z)$  and  $b_1(z)$  are numerator and denominator polynomials, respectively, with the structure of Equations (3) and (4). The linearly correlated signal  $e_L(t)$  is then generated from

$$e_L(t) = W(t) - Y_L(t) \quad (11)$$

The above process is then repeated by reapplying superposition to obtain the following relation between  $\delta(t)$  and  $W(t)$ :

$$\delta(t) = G_3(z)W(t) + G_4(z)R(t) \quad (12)$$

$$\delta_L(t) \triangleq G_3(z)W(t) \quad (13)$$

The cross correlation identification (Appendix) applied to the sequence  $\delta(t)$  and  $W(t)$  yields the initial segment of pulse response sequence  $g_3(z)$ , and the polynomials  $a_3(z)$  and  $b_3(z)$  may be determined (see next section) such that

$$G_3(z) = a_3(z)/b_3(z) \quad (14)$$

Pilot output linearly correlated with  $W(t)$  is generated from the autoregressive relation

$$b_3(z) \delta_L(t) = a_3(z)W(t) \quad (15)$$

Finally, the cross correlation technique (Appendix) is applied to  $\delta_L(t)$  and  $e_L(t)$  to find the initial segment of  $g_p(k)$ , defined by the coefficient set  $\{g_{pk}, 0 \leq k < N\}$ , of the pilot model pulse response. Numerator and denominator polynomials are then found (see next section) which yields

$$G_p(z) = \delta_L(z)/e_L(z) \quad (16)$$

No multiplication or divisions of transfer functions occurs throughout the above procedure.

#### 4. MODEL STABILITY

As mentioned above, the pulse response sequence identified [ $g_1(z)$ ,  $g_3(z)$  and  $g_p(z)$ ] will be truncated at some finite lag "k" final task is to find a parsimonious numerator polynomial stable denominator polynomial which together are equivalent mathematically to the identified pulse response. These polynomials are chosen to have the structure shown in Equation (2), which is re-arranged into the following form:

$$(1 + \sum_{i=1}^s b_i z^{-i}) (\sum_{k=0}^{kmax} g_k z^{-k}) = K(1 + \sum_{k=1}^{\ell} a_k z^{-k}) \quad (17)$$

$$kmax > s \geq \ell$$

Since the pulse response  $g_k$  is known for  $0 < k < N$ , by equating coefficients for the operator "z" at each exponential power " $\lambda$ ", relationships may be found between numerator and denominator coefficients  $a_k$  and  $b_k$ . Moreover, by equating coefficients for the operator z above power "s", for which the right side of equation (15) vanishes, one obtains for every  $j > 0$

$$g_{s+j} + g_{s+j-1}b_1 + \dots + g_{s+j-s}b_s = 0 \quad (18)$$

The above relation exists for a finite but large number of " $J > 0$ ", so projection theory (least squares) may be used to coefficients  $b_k$  ( $0 < k \leq s$ ). Bringing term " $g_{s+j}$ " to the other side of equation (18) and divided by " $g_{s+j}$ " one may write

$$A[b_1, b_2, \dots, b_s]^T = [-1, \dots, -1]^T \quad (19)$$

and the " $j$ "th row of A is given by

$$\left| \frac{g_{s+j-1}}{g_{s+j}}, \frac{g_{s+j-2}}{g_{s+j}}, \dots, \frac{g_{s+j-s}}{g_{s+j}} \right| \quad j > 0 \quad (20)$$

1 by s

The solution from linear algebra is

$$[b_1, b_2, \dots, b_s]^T = -(A^T A)^{-1} A^T [1, \dots, 1]^T \quad (21)$$

To provide a parsimonious denominator, the solution of Equation (21) is accepted for the lowest order "s" which has both a stable characteristic equation (i.e. roots less than 1.0 in magnitude) and which yields a model pulse response similar in shape to the truncated pulse response identified from the data. Once a stable denominator is found the numerator a(z) and the gain K may be determined by once again matching coefficients in Equation (17);

$$K = g_0 \quad (22)$$

$$a_k = \frac{1}{K} \left[ g_k + \sum_{i=1}^{i=k} b_i g_{k-i} \right] \quad 0 < k \leq \ell \quad (23)$$

By defining error residual to be the actual output time series minus the pilot model output series at each sample instant, the gain K may be adjusted by a suitable minimization technique to minimize the error residual variance. Alternatively, it may be adjusted to provide a steady state response of unity when the input to the transfer function is a unity pulse train, a constraint recommended by Agarwal (1980).

If a time delay " $\tau$ " is to be included, the final form of  $G_p(z)$  will be as shown in Equation (2), and the indices for the pulse responses in Equations (17)-(23) should be incremented by the integer " $\tau$ " during identification (for example the gain K from Equation (2) equals  $g_\tau$  identified from the data).

Validation tests may also be applied to the model. There are two types of tests: acceptability and statistical significance. Acceptability tests are common sense checks which compare model output series versus actual autocorrelation estimates from the data, autocorrelation of residuals for whiteness properties, and checks for negligible cross-correlation between the noise inputs.

Statistical significance tests may be performed after acceptability tests indicate the model is reasonable. Chi-squared statistics are available from the  $w(t)$  and  $v(t)$  prewhitened series (discussed in the Appendix and shown in Figure 13). Assuming one can safely neglect correlations beyond a lag of 20, for example, the statistics to be computed are, for "whiteness" of  $v(t)$

$$(N-p) \sum_{k=1}^{20} \left\{ \frac{1}{(N-k)} \sum_{t=k}^N v(t-k)v(t) \right\} \quad (24)$$

and, for uncorrelated  $w(t)$  and  $v(t)$

$$(N-p) \sum_{k=1}^{20} \left\{ \frac{1}{(N-k)} \sum_{t=k}^N w(t-k)v(t) \right\} \quad (25)$$

$p$  = order of  $\Omega_v(z)$  filter

$N$  = total points in data set

which should pass the chi-squared significance test for degrees of freedom  $(20-p)$  and  $(20-1-s-1)$  respectively (Box and Jenkins, 1976, p.394). Failure of either significance test is evidence of a faulty assumption or a modeling inadequacy.



To summarize the modified superposition technique

- a) Find a finite pulse sequence relating  $y(t)$  and  $W(t)$  using cross correlation identification (Appendix).
- b) Determine a parsimonious, stable transfer function  $G_1(I)$  which is mathematically equivalent, in the least squares sense, to the sequence identified from the data  $g_1(z)$  [Equation (9)].
- c) Generate time series realizations  $\{y_L(t)\}$ ,  $\{e_L(t)\}$  using Equations (10) and (11).
- d) Find a finite pulse sequence,  $g_3(z)$ , relating  $\delta(t)$  and  $W(t)$  using cross correlation identification, and determine a stable transfer function  $G_3(\tau)$  for this pulse response (Equation (14)).
- e) Generate time realization  $\delta_L(t)$  using Equation (15).
- f) Find a finite sequence of the pulse response  $g_p(z)$ , from  $\delta_L(t)$  and  $\delta_L(t)$  using cross correlation identification, and fit a stable pilot model transfer function  $G_p(\tau)$  to this pulse response (Equation (16)).
- g) Adjust  $K$  if desired and validate the model.

## 5. PILOTED LABORATORY SIMULATION

Single-channel "piloted" simulations in the Flight Simulation Laboratory at Purdue University were accomplished with a pilot performing pursuit tracking tasks using a single and double integrator ( $K/s$  and  $K/s^2$  respectively) controlled element dynamics. The task involved a command disturbance input of a random appearing forcing function, and a standard pursuit (McRuer, 1974) display using a CRT Monitor. Data sets were obtained at a 20 hertz sample rate and 500 points were used for modeling, providing a record length of only 25 seconds (although the data run itself exceeded 60 seconds).

For the single-integrator controlled element many low-order transfer functions provided excellent "fits," and the lowest order model is shown in Table 1. A "direct identification" neglecting the closed-loop structure was also performed by merely fitting signals  $\{\delta(t)\}$  and  $\{e(t)\}$ , and a comparison of those results in Table 1 shows little variation in parameter values between direct and indirect identification in this case. This implies a small value for pilot injected noise relative to stick output (See Figure 1), a reasonable

deduction for a "simple" controlled element such as K/s. An a priori selected time delay of 0.2 seconds yielded the lowest error residual variance and is consistent with previous results (Bredderman, 1976).

A frequency response of the identified transfer function is shown in Figures 2 and 3 where it is clear that a delay in series with a pure gain effectively describes pilot behavior. This is consistent with classical pilot modeling results (McRuer, 1974). Since a conventional Bode interpretation and analysis using these frequency responses is not valid over all frequencies in discrete systems z-domain analysis, a transformation of variables from z to w' was accomplished using (Franklin and Powell, 1980, p.114)

$$w' \triangleq \frac{2}{\Delta} \frac{(z-1)}{(z+1)}$$

$$v \triangleq \frac{2}{\Delta} \tan \frac{\omega \Delta}{2} \tag{27}$$

Figures 4 and 5 show the transformed frequency (v) response in the w' domain, where a conventional Bode interpretation is allowed. By comparing Figures 4 and 5 with Figures 2 and 3, one can find no discernable difference between the responses over the frequency range of interest (0 ω 25 rps).

The time histories are shown in Figure 6. Only the first 500 points (25 seconds) were used to develop the model, and the model output remains reasonably accurate beyond this time. This verifies stationarity and avoids an overfit (Kashyap, 1976), which would be evidenced by increased error residual when the model is applied to data independent of model derivation (in this case beyond 25 seconds).

For the double-integrator controlled element a more complex transfer function was identified and is shown in Table 2 for two values of a priori selected time delay (0.05 seconds and 0.2 seconds).

From the frequency response plot in Figure 7 there is some resonance near 2.0 Hz. The phase plots are shown in Figures 8 and 9 for two different values of time delay (0.2 and 0.05 seconds respectively). The transformation to w' domain yields no discernable difference from these responses and they are not shown.

In contrast to control of a "simple"  $K/s$ , the "best fit" (minimizing residual error variance) was obtained when time delay was set to 0.05 control for of  $K/s^2$ . The phase contribution (from the poles and zeros) of the discrete transfer function is apparent as time delay changes between 0.2 seconds and 0.05 seconds, as may be seen by the phase plots of Figures 10 and 11 in which the pure time delay has been removed from the discrete transfer function. Selecting the larger pure time delay for the model exposes the considerable lead generation from the transfer function poles and zeros. This lead generation is not as apparent when pure time delay is reduced for the "best time domain" fit, but the resulting 0.05 seconds might be judged too fast to associate with a lumped physiological delay for a human operator. A possible explanation is unmodeled pilot anticipation; that is, a possible anticipatory loop closure not accounted for in Figure 1.

Further evidence of this is provided in the time history for the best fitting model in Figure 12. Note that a seasonal pilot residual (where pilot output "leads" model output) occurs during some of the longer intervals of large slope. This could be caused by momentary anticipatory behavior arising from the "pursuit" display including commanded input, a factor not accounted for in a time invariant model. Thus in determining the "best" model using time series analysis, the purpose of the model must be given as much consideration as tests for "best fit."

In summary for the  $K/s^2$  controlled element, an a priori time delay in series with a rate sensitive gain describes "pilot" behavior over his usable bandwidth, in agreement with classical results (McRuer, 1974). When pure time delay is not set a priori but allowed to vary in obtaining the "best time domain fit," the minimization of an error variance criterion results in a math model where the time delay is perhaps too small to be associated with physiological operator delays. This case is associated with a pursuit task in which the command as well as the plant output is displayed.

## 6. CONCLUSIONS

A modified superposition technique was described for obtaining a parsimonious and stable discrete transfer function, along with statistical tests for model validation. Results provide evidence that the time series technique appears feasible to implement on "short" data records. The analyst needs, however, to determine the criterion for a "best time domain fit" which allows association of parameter values, such as pure time delay, with actual physical and physiological constraints. Seasonalities in pilot residual, possibly caused by anticipatory behavior, were observed as first noted by Shinnars (1974), and are not well modeled with a time invariate model.

Future work should concentrate on the full potential of these time series models for analyses, especially their ability to provide stable and accurate power spectral densities, and on their application to multi-channed closed-loop pilot modeling.

## 7. ACKNOWLEDGMENT

The authors express their gratitude to Mr. Yuan Pin-Jar, who is responsible for the laboratory computer programs and display setup used in the simulations, and to Mr. Chuck Malmsten for assistance in computer operation, maintenance, and data retrieval.

8. APPENDIX: Cross Correlation Identification  
(Box and Jenkins, 1976)

Given the situation in Figure 13, the goal is to find the pulse response relating  $Y(t)$  and  $W(t)$ , which is prewhitenable by  $w_w(z)$ . The prewhitening is accomplished by applying the Levinson-Durbin algorithm as given by Kay and Marple (1981, pp. 1388-1389). By reversing the order of the blocks in the forward path of Figure 13, and multiplying each signal at the summer by

$\Omega_w^{-1}(z)$ , the following equation results:

$$G(z)w(t) + \Omega_w^{-1}(z)V(t) = \beta(t) \quad (28)$$

$$\beta(t) = \Omega_w^{-1}(z)y(t) \quad (29)$$

Now multiply Equation (28) by  $w(t-k)$  and take the expectation, recalling that  $w(t)$  is uncorrelated by assumption with  $v(t)$ :

$$G(z) E[w(t)w(t-k)] = E[\beta(t)w(t-k)] \quad (30)$$

By expanding  $G(z)$  using shift properties of  $z$  one obtains

$$(g_0 + g_1 z^{-1} + g_2 z^{-2} + \dots) E[w(t)w(t-k)] = E[\beta(t)w(t-k)] \quad (31)$$

Since  $w(t)$  is an independent, identically distributed sequence of random numbers with variance  $\sigma_w^2$ , one obtains for every lag  $k$

$$g_k \sigma_w^2 = E[\beta(t)w(t-k)] \quad (32)$$

$$k > 0$$

Conventional estimation relations may now be used to estimate the terms in Equation (32) and solve for  $g_k$ ; for example, from Box and Jenkins (1976, pp. 32-33) one obtains

$$\hat{g}_k \left\{ \frac{1}{N} \sum_{t=1}^N w(t)w(t) \right\} = \left\{ \frac{1}{N-k} \sum_{t=k}^N \beta(t)w(t-k) \right\} \quad (33)$$

which determines the pulse response sequence estimate  $g_k$ .

## REFERENCES

1. Bacon, B. and Schmidt, D., "An Optimal Control Approach to Pilot Vehicle Analysis and the Neal Smith Criteria," "AIAA Journal of Guidance, Control, and Dynamics," Vol. 6, No. 5, Sept. -Oct. 1983, pp. 321-330.
2. Baron, Muralidharan, and Kleinman, "Closed Loop Models for Analyzing Engineering Requirements for Simulators," NASA Rept. 2965, Feb. 1980.
3. Box, G. and Jenkins, G., Time Series Analysis: Forecasting and Control, San Francisco, Holden Day, 1976.
4. Breddermann, Glockner, and Henninset, "On the Identifiability of the Human Controller in a Closed Loop System," Identification and System Parameter Identification, Rajbman ed., North Holland, 1978.
5. Franklin, G. and Powell, J., "Digital Control of Dynamic Systems," Addison-Wesley, 1980.
6. Goto and Washizu, "On the Dynamics of Human Pilots in Marginally Controllable Systems," AIAA Journal of Aircraft, Vol. 12, NO. 3, March 1974, pp. 310-315.
7. Harper, R., "Handling Qualities of Flight Vehicles," internal memo, Flight Research Department, CALSPAN Advanced Technology Center, Buffalo, New York.
8. Hess, R., "Prediction of Pilot Opinion Rating Using an Optimal Pilot Model," Human Factors, Vol. 10, No. 5, Oct. 1977, pp.459.
9. Hoh and Mitchell, "Low-Order Approaches to High Order Systems Problems and Promises," AIAA Journal of Guidance and Control, Vol. 5, No. 3, Sept.-Oct. 1982, pp. 482.
10. Kashyap and Roa, Dynamic Stochastic Models from Empirical Data, Academic Press, 1976.
11. Kleinman, D., "A Predictive Pilot Model for STOL Aircraft Landing," NASA CR-2374, March 1974.
12. Kleinman, Baron, and Levinson, "Optimal Control Model of Human Response," Automatica, Vol. 6, No. 3, 1970.

13. McRuer, Graham, Krendel, and Reisener, "Human Dynamics in Compensatory Systems," AFFDL-TR-65-15, Wright-Patterson AFB, Ohio, July 1965.
14. McRuer and Krendel, "Mathematical Model of Human Pilot Behavior," AGARD AG-188, January 1974.
15. Palmer, "Large Scale Systems: Ststems, Man, and Cybernetics Overview," IEEE Transactions on Automatic Control, Vol. AC-28, No. 6, June 1983.
16. Rosenbrock, H., "The Proper Use of Human Ability: A Challenge to Engineers," IFAC Newsletter, No. 5, Oct. 1983.
17. Rouse, W., Systems Engineering Models of Human-Machine Interaction, North Holland, 1980.
18. Schmidt, D., "Optimal Flight Control Syntheses Via Pilot Modeling," AIAA Journal of Guidance and Control, Vol. 2, No. 4, July 1979.
19. Sheridan and Ferrell, Man Machine Systems, MIT Press, 1974.
20. Shinnars, S., "Modeling of Human Operator Performance Utilizing Time Series Analysis," IEEE Transactions on SMC, Vol. SMC-4, No. 5, pp. 446-458, September 1974.

Table 1 Discrete Transfer Function Identification  
Results for Controlled Element K/s (K = 1)

$$\text{Model Structure } G_p(z) = \frac{K_p^{-\tau}(1+a_1z^{-1})}{(1+b_1z^{-1})}$$

Signal to noise ratio = 50

N = 500 points     $\Delta = 0.05$  seconds     $\tau = 4$  (0.2 seconds)

Parameter	Modified Superposition Value	Direct Identification
$K_p^*$	0.64	0.69
$K_p^{**}$	0.79	0.72
$a_1$	0.71	0.69
$b_1$	0.32	0.37

\* Gain which minimizes error residual variance

\*\* Gain yields steady state step response of unity



Table 2 Modified Superposition Identification Results  
for Controlled Element  $K/s^2$  ( $K = 1$ )

$$\text{Model Structure } G_p(z) = \frac{Kz^{-\tau}(1+a_1z^{-1})}{(1+b_1z^{-1}+b_2z^{-2}+b_3z^{-3})}$$

Signal to noise ratio  $\approx 30$

$N = 500$      $\Delta = 0.05$  seconds     $\tau = 4$  (0.2 seconds)

Parameter	$\tau = 0.05$ sec	$\tau = 0.2$ seconds
$K_p^*$	0.03	0.89
$K_p^{**}$	0.033	1.22
$a_1$	10.9	-0.67
$b_1$	- 1.42	-1.41
$b_2$	0.91	0.88
$b_3$	- 0.1	-0.06
Roots	0.14 0.64 $\pm j$ 0.57	0.08 0.67 $\pm j$ 0.57

\* Gain which minimizes error residual variance

\*\* Gain yields steady state step response of unity

Figure 1 Linear Discrete Closed-loop Pilot Model

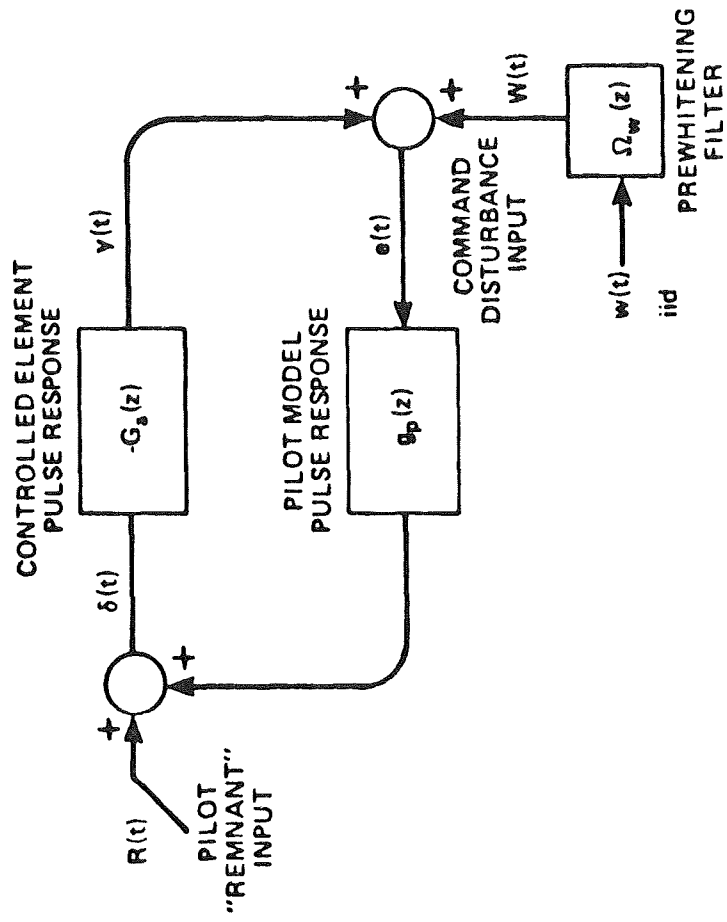

Figure 2 Manual Controller Frequency Response Magnitude:  
Controlled Element K/s

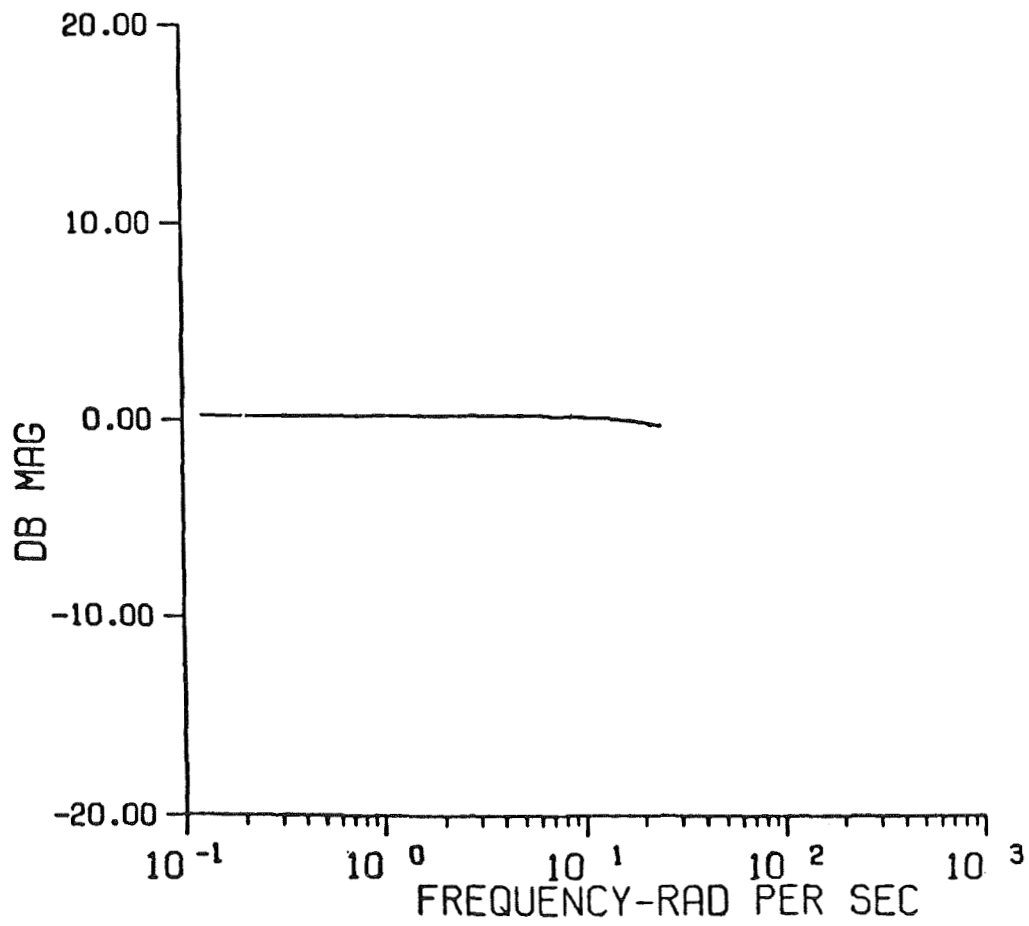

Figure 3 Manual Controller Frequency Response Phase:  
Controlled Element K/s

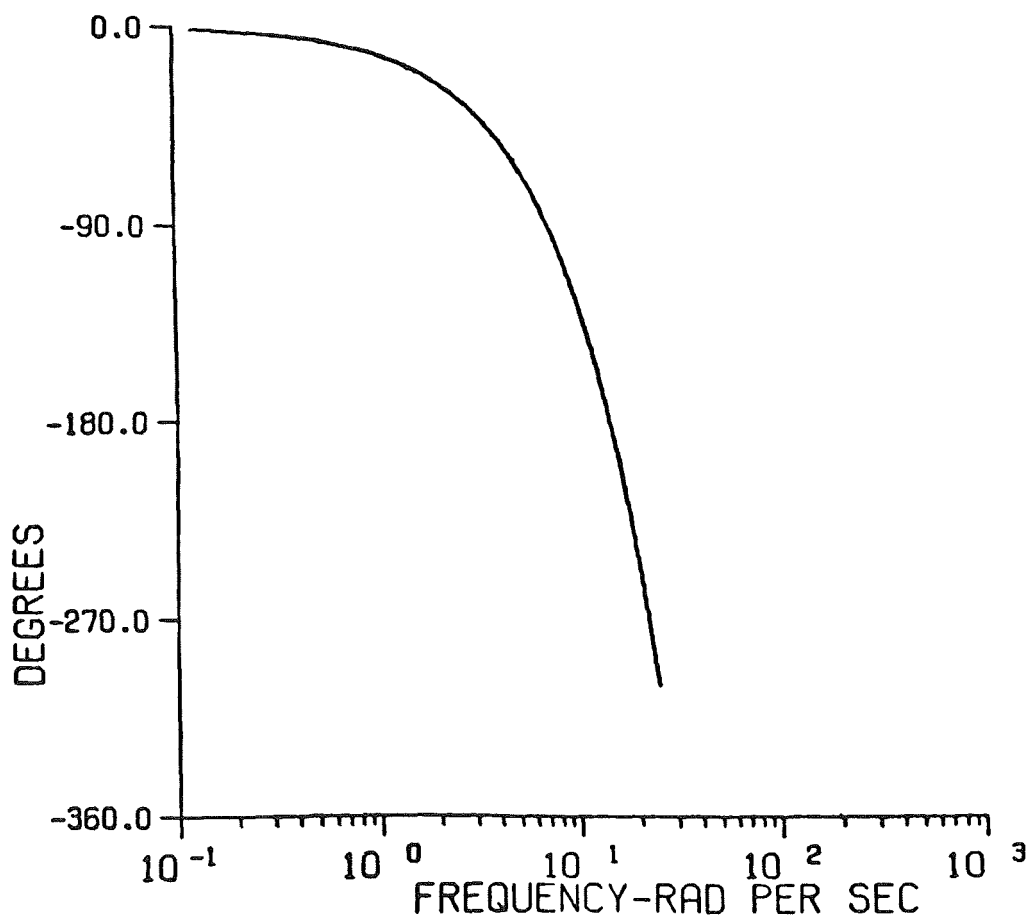

Figure 4 W' Response Magnitude: Controlled Element K/s

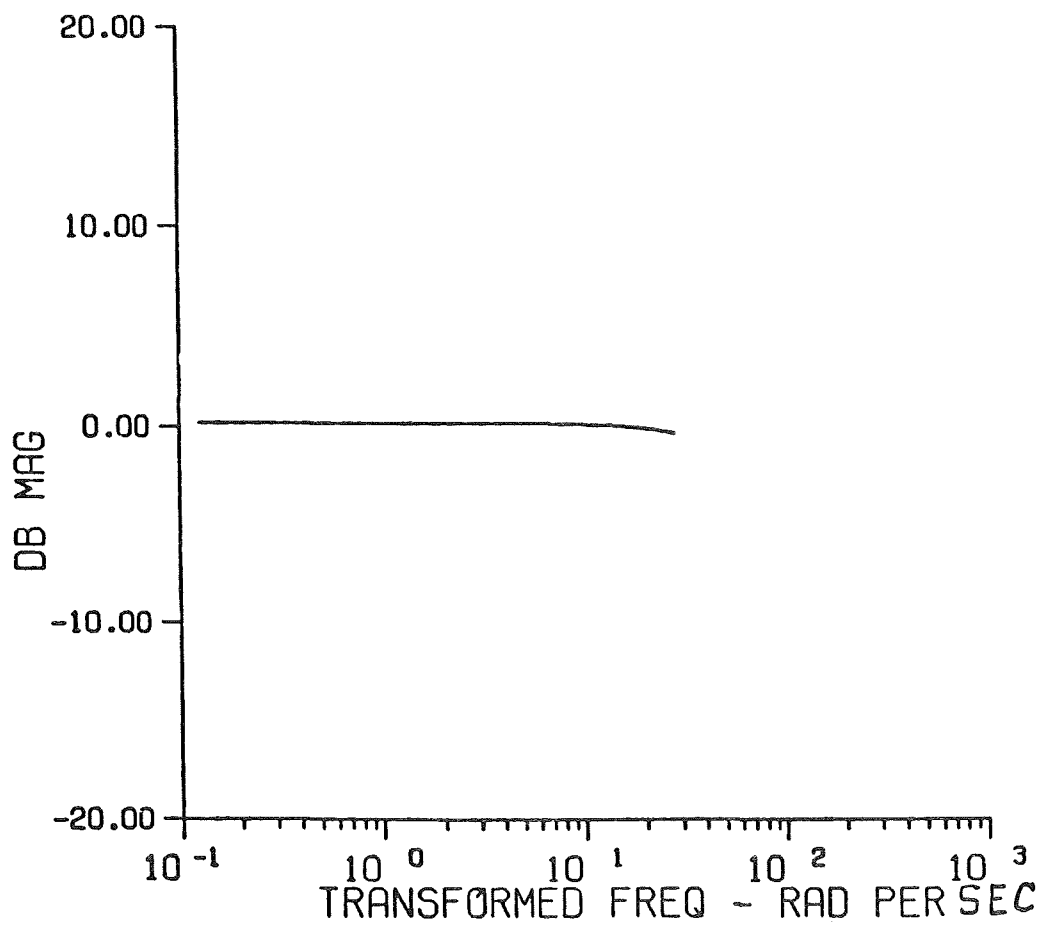

Figure 5 W' Response Phase: Controlled Element K/s

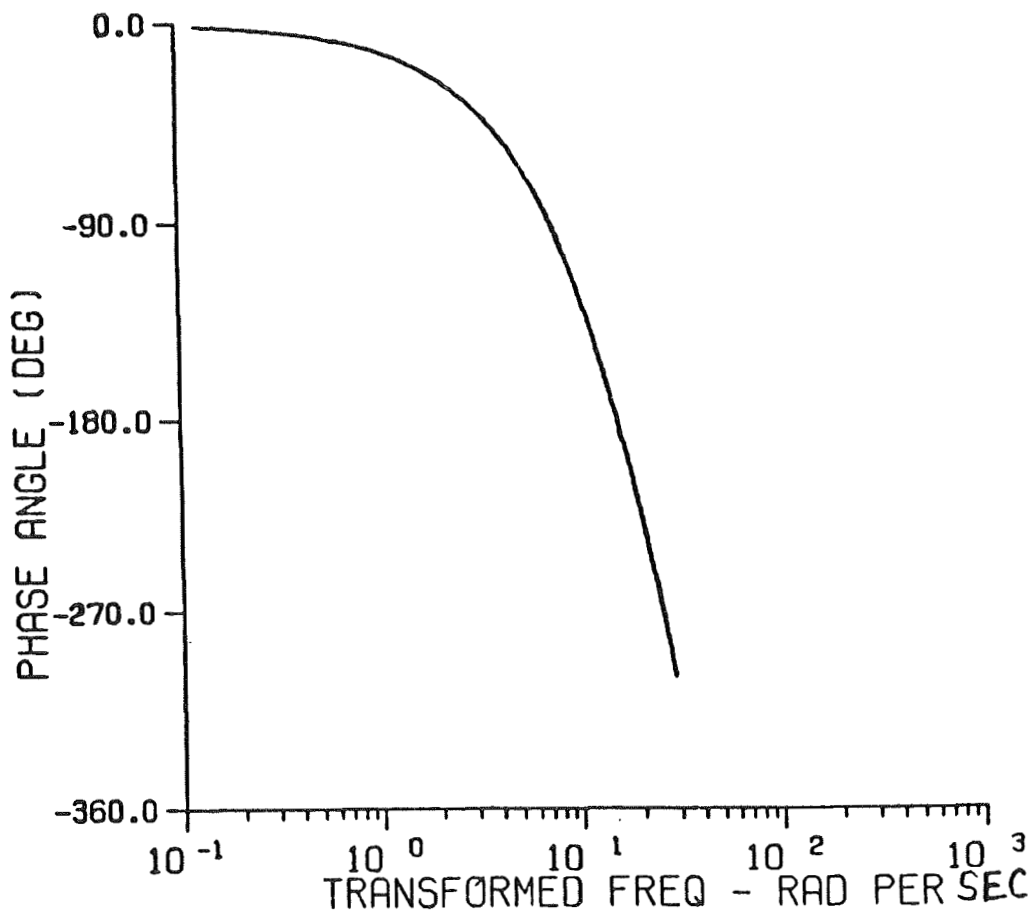

Figure 6 Model Output vs. Pilot Output: Controlled Element K/S

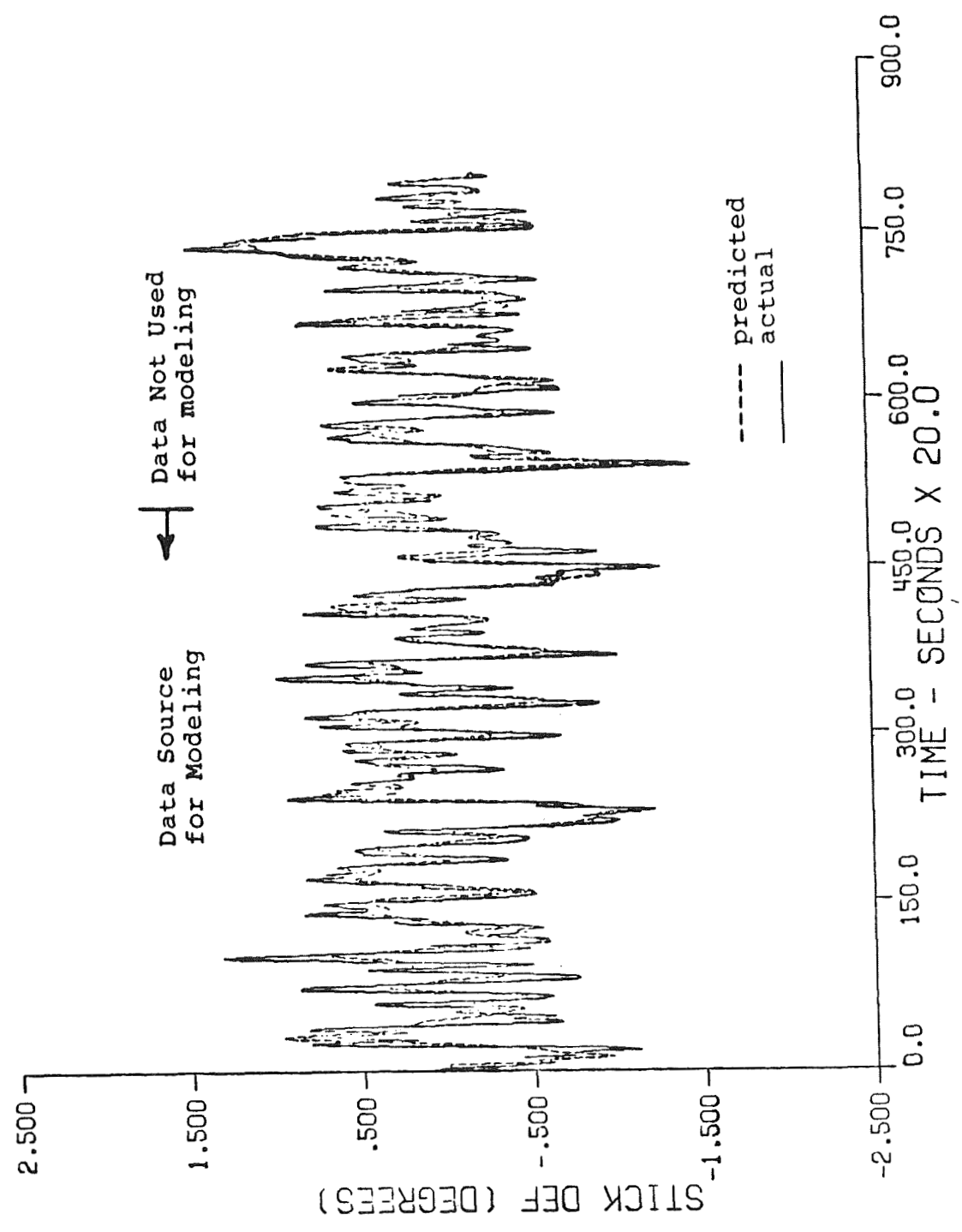

Figure 7 Manual Controller Frequency Response Magnitude:  
 $K/s^2, \tau = 0.2$  seconds

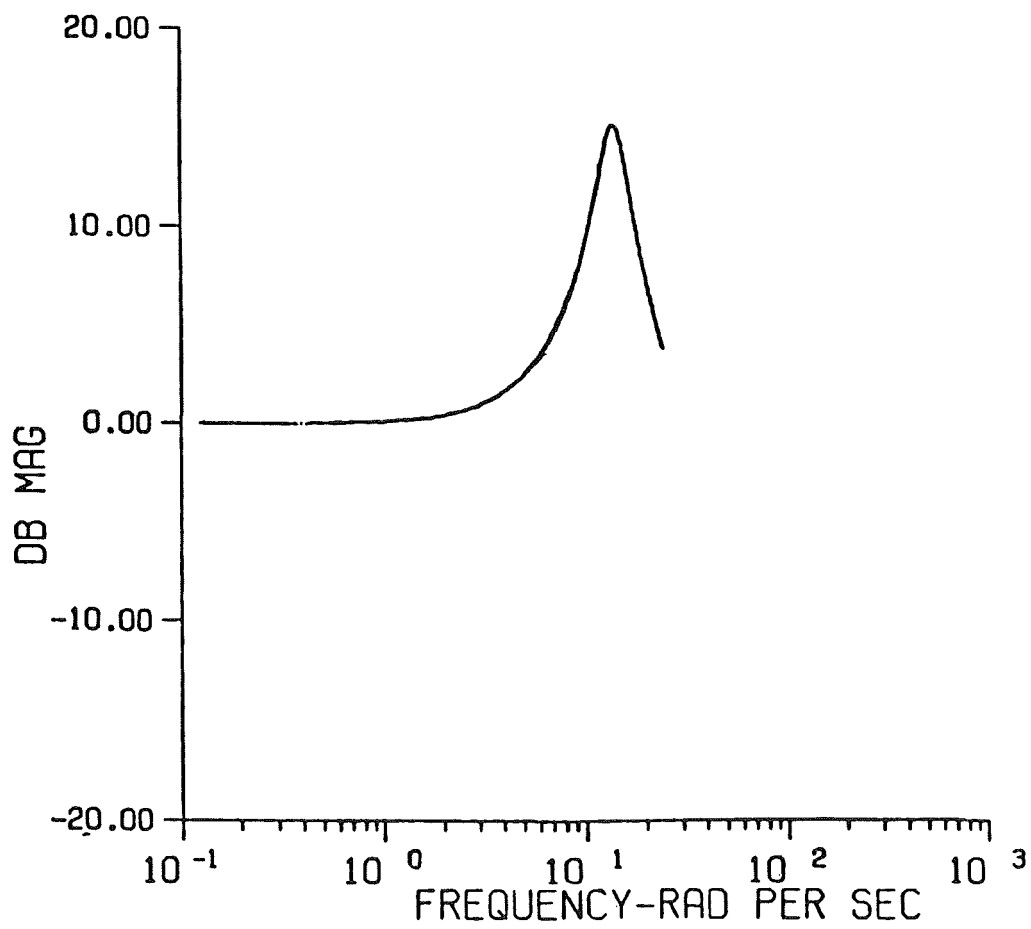



Figure 8 Manual Controller Frequency Response Phase:  
 $K/s^2, \tau = 0.2$  seconds

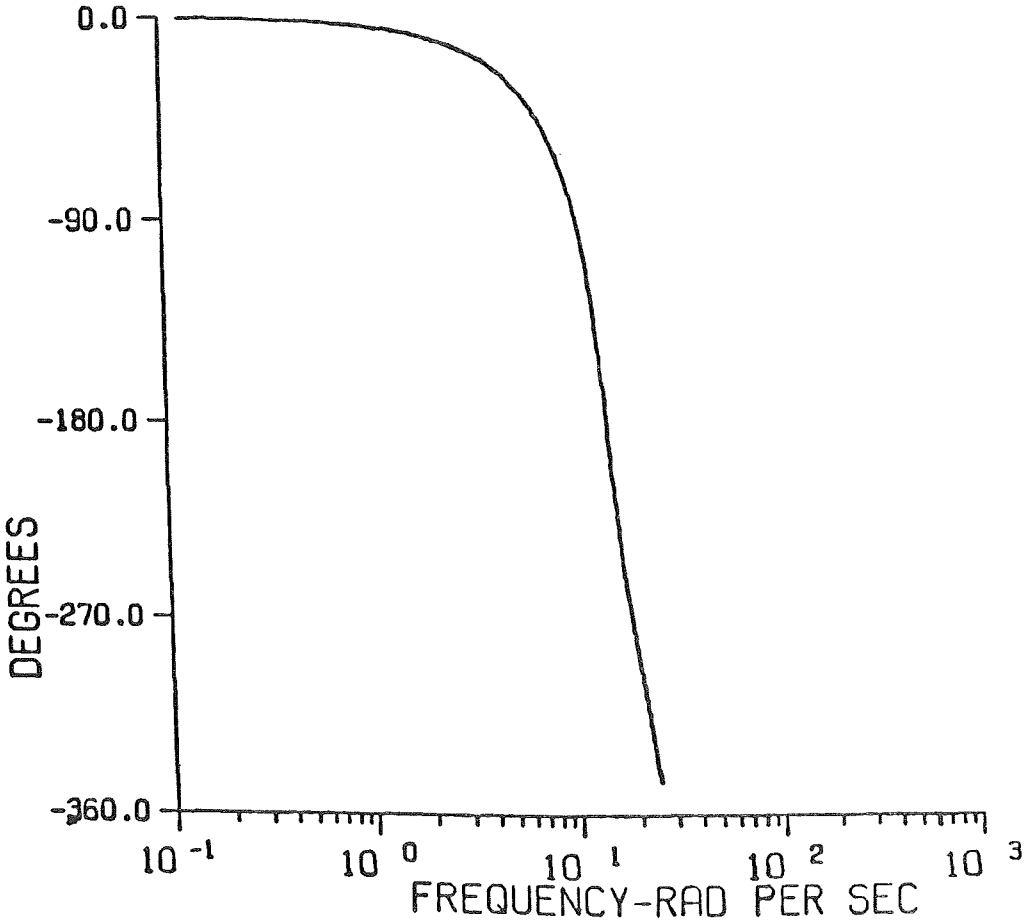

Figure 9 Manual Controller Frequency Response Phase:  
 $K/s^2, \tau = .05$  seconds

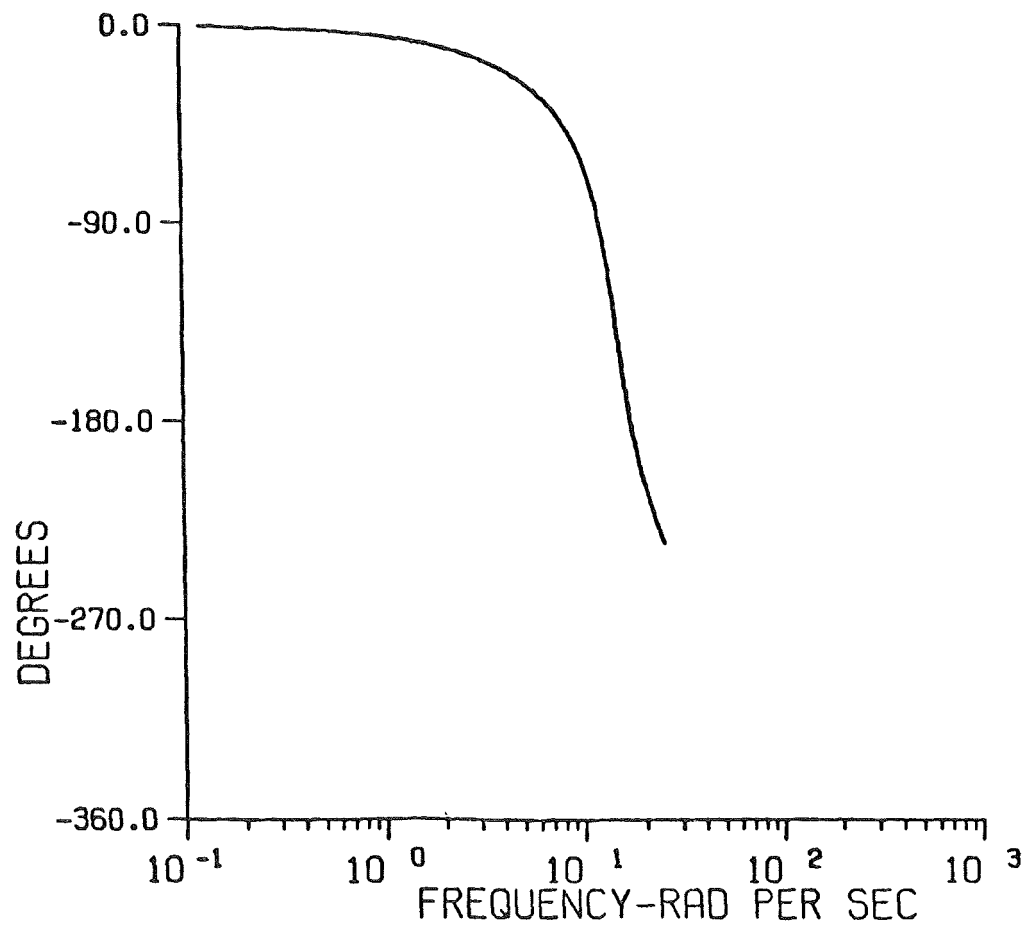

Figure 10 Manual Controller Frequency Pole-zero Response Phase:  
 $K/s^2$ ,  $\tau = 0.2$  seconds

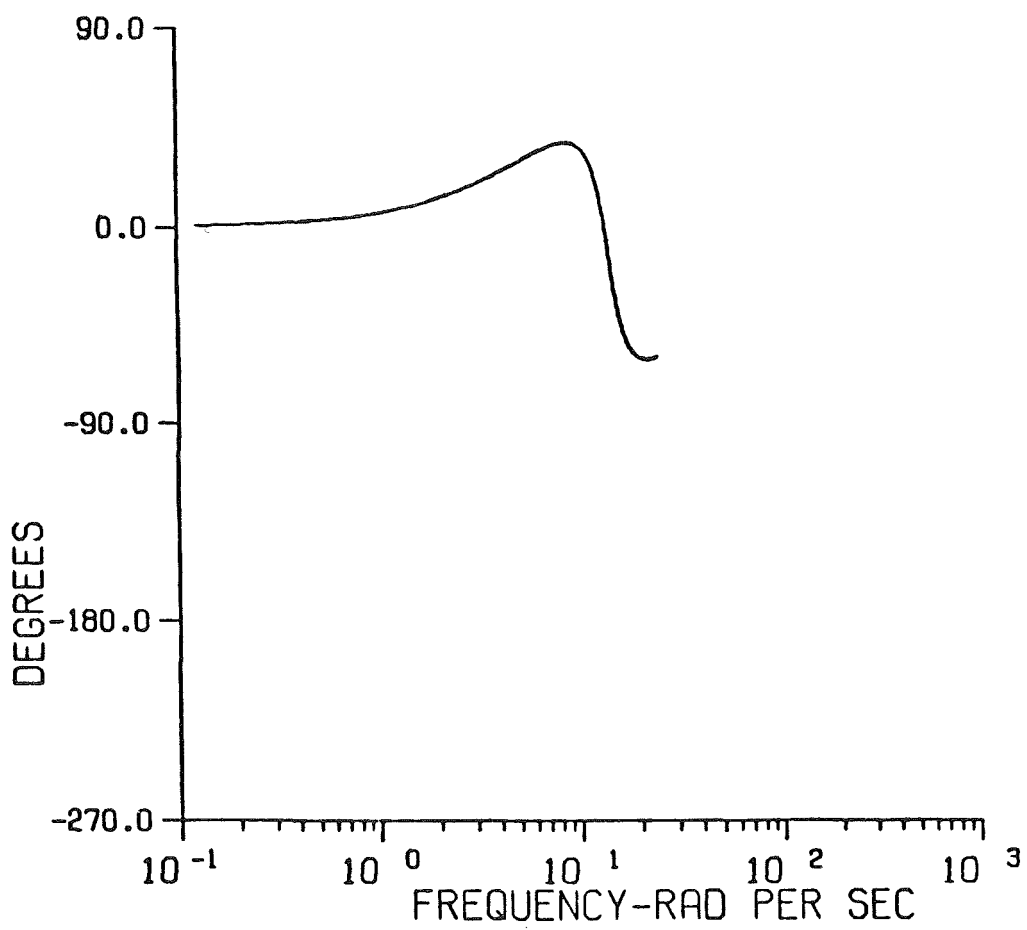

Figure 11 Manual Controller Frequency Pole-zero Response Phase:  
 $K/s^2, \tau = 0.5$  seconds

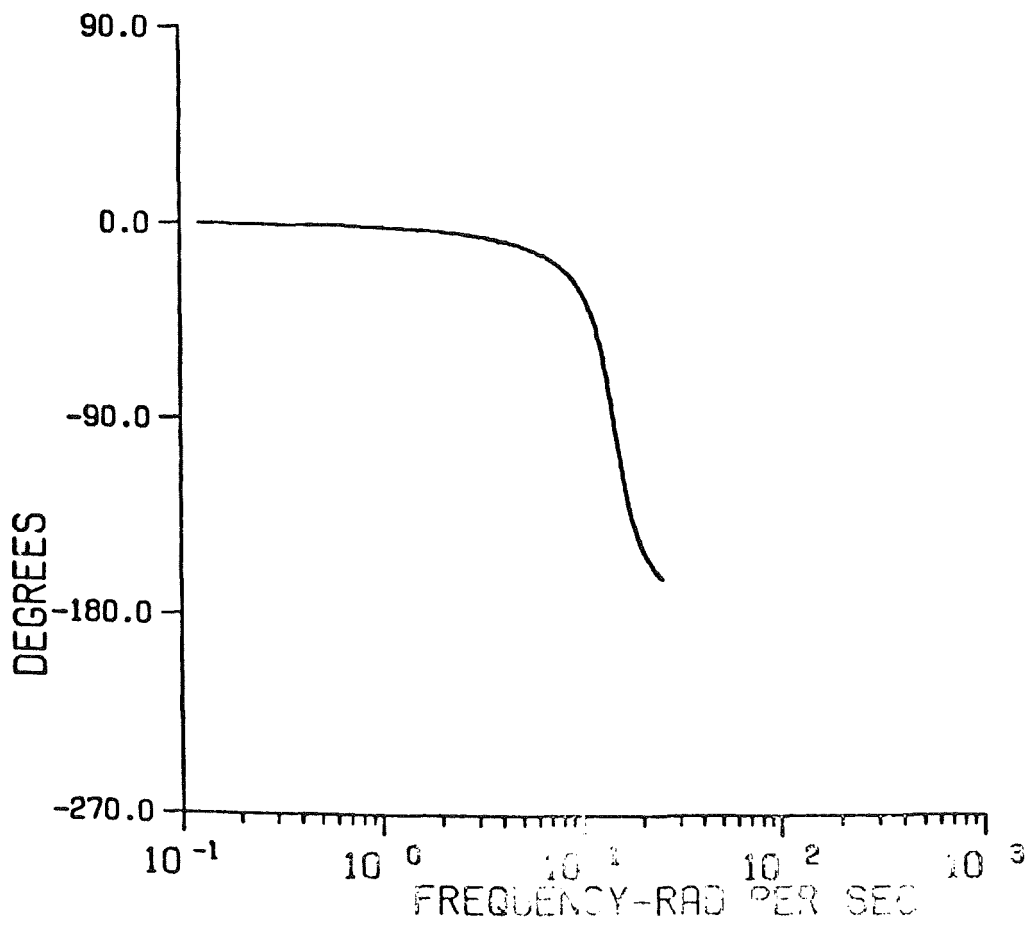

Figure 12 Model Output vs. Pilot Output:  $K/s^2$ ,  $T = 0.5$  seconds

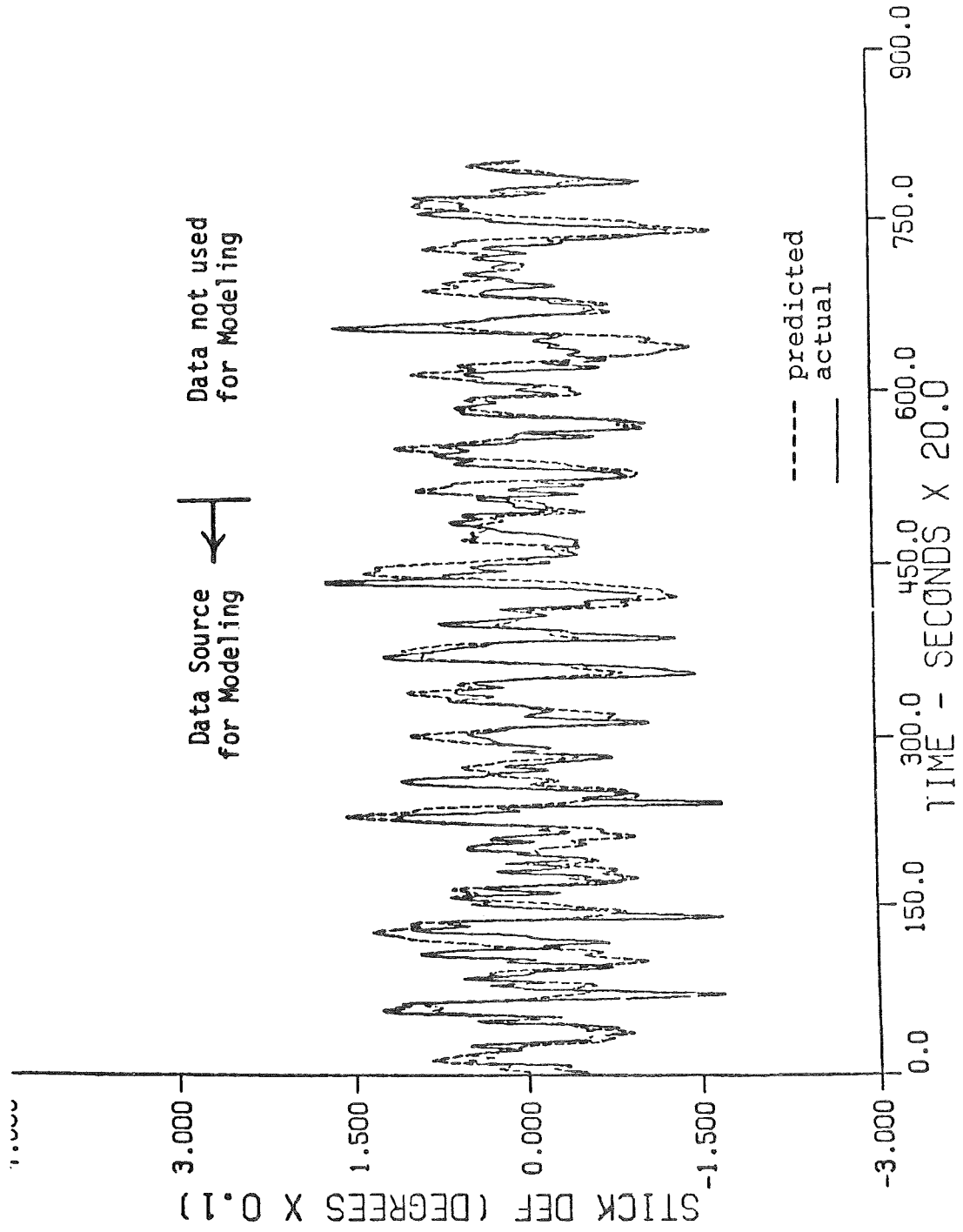

FIGURE 13: Linear Discrete Model for Cross Correlation Identification

