

1N-23669

NASA CASE NO. NPO-16, 869-1CV

PRINT FIG. 2 16 P.

NOTICE

NPO 894694

The invention disclosed in this document resulted from research in aeronautical and space activities performed under programs of the National Aeronautics and Space Administration. The invention is owned by NASA and is, therefore, available for licensing in accordance with the NASA Patent Licensing Regulation (14 Code of Federal Regulations 1245.2).

To encourage commercial utilization of NASA-owned inventions, it is NASA policy to grant licenses to commercial concerns. Although NASA encourages nonexclusive licensing to promote competition and achieve the widest possible utilization, NASA will consider the granting of a limited exclusive license, pursuant to the NASA Patent Licensing Regulations, when such a license will provide the necessary incentive to the licensee to achieve early practical application of the invention.

Address inquiries and all applications for license for this invention to NASA Resident Office-JPL, NASA Patent Counsel, Mail Code 180-801, 4800 Oak Grove Dr., Pasadena, CA 91103. Approved NASA forms for application for nonexclusive or exclusive license are available from the above address.

(NASA-Case-NPO-16869) COMPENSATION FOR
PRIMARY REFLECTOR WAVEFRONT ERROR Patent
Application (NASA) 16 P CSCL 20F

N86-33138

G3/74 Unclas
44161

Patent No.	867,986
Filing Date	5/29/86
Contract No.	N 87-913
Contractor	Caltech/JPL
Pasadena (City)	CA (State)
	91109 (Zip)

AWARDS ABSTRACT

Contractor: Jet Propulsion Laboratory

JPL No. 16869
NASA NPO-16869-
1-CU

Inventors: Aden B. Meinel
Marjorie P. Meinel
John E. Stacy

May 21, 1986

COMPENSATION FOR PRIMARY REFLECTOR WAVEFRONT ERROR

The object of the disclosure is to compensate for errors in a large telescope primary reflector, by making certain compensating deviations in a smaller, auxiliary reflector of the telescope.

In the Gregorian telescope of Fig. 1, applicant adds an intermediate lens 40 which forms an image of the surface of the primary mirror 12 onto the surface of the secondary or auxiliary mirror 14. As a result, every point on the auxiliary mirror surface corresponds to a point on the primary mirror surface. To compensate for a deviation area 32 in the primary surface, where the actual primary surface 30 deviates from an "ideal" primary surface 16, applicant creates a deviation area 34 in the auxiliary surface, where the actual auxiliary surface 36 deviates from an "ideal" auxiliary surface. Fig. 3 contains enlarged views of the primary deviation area 32 and the auxiliary deviation area 34. Each point such as 54a on the actual auxiliary surface deviates by a distance 54e from the ideal auxiliary surface 18, by an amount substantially equal to the deviation 54d of a corresponding point 54p on the primary surface from the ideal primary surface 16. Fig. 4 shows a Cassegrain system where secondary and tertiary mirrors 84, 86 form an image of the surface of the primary mirror 82 onto the auxiliary mirror 88. Each point on the auxiliary surface 92 (in the deviation area thereof) has a piston deviation from the ideal auxiliary surface equal and opposite to the piston deviation of the actual primary surface 90 from the ideal primary surface 94.

A major novel feature of the invention is the compensation for an error in a large primary mirror surface, by forming an image of the primary surface onto an auxiliary surface, and introducing a deviation on each point of the auxiliary surface, from the ideal auxiliary surface, which is substantially equal to but opposite the deviation of the corresponding point on the actual primary surface from the ideal primary surface.

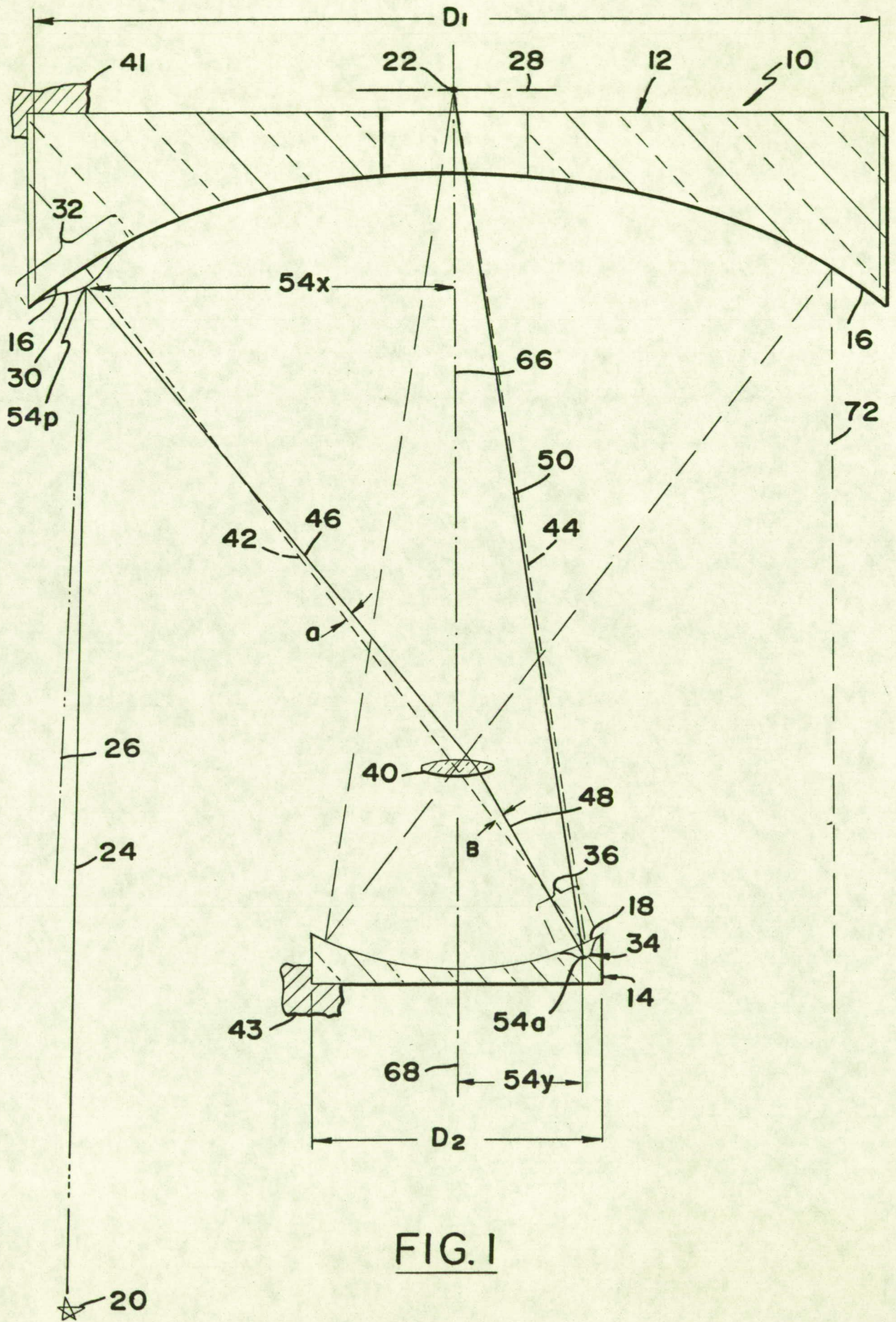

FIG. 1

FIG. 2

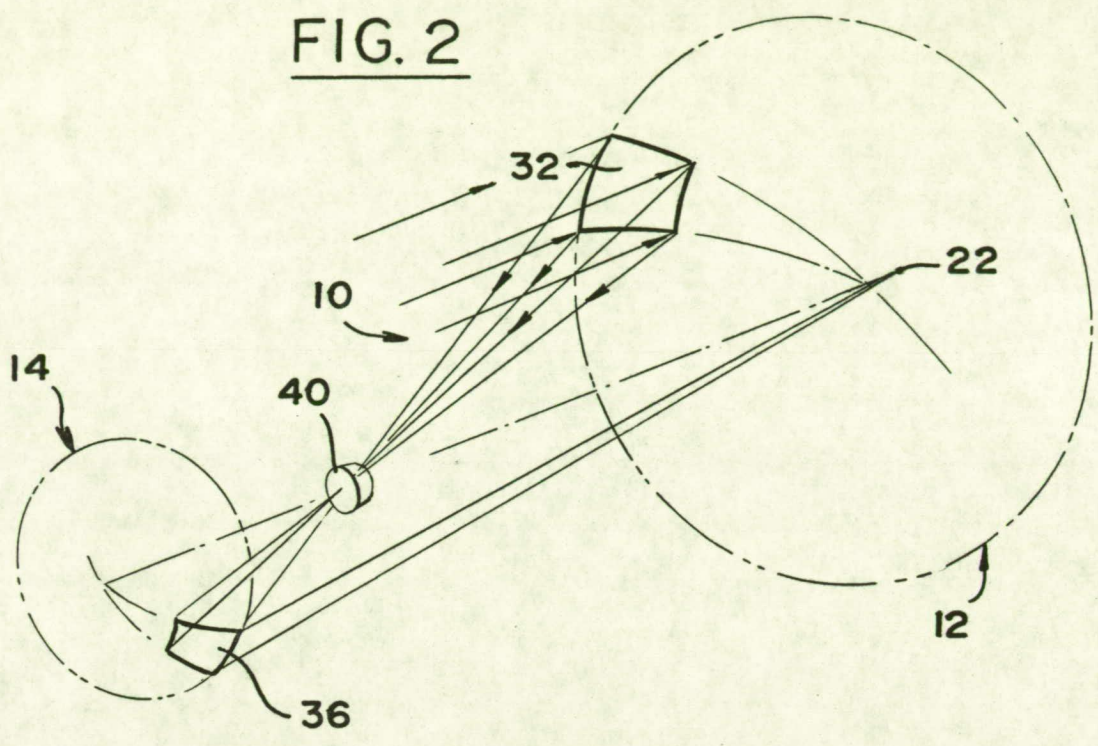

FIG. 3

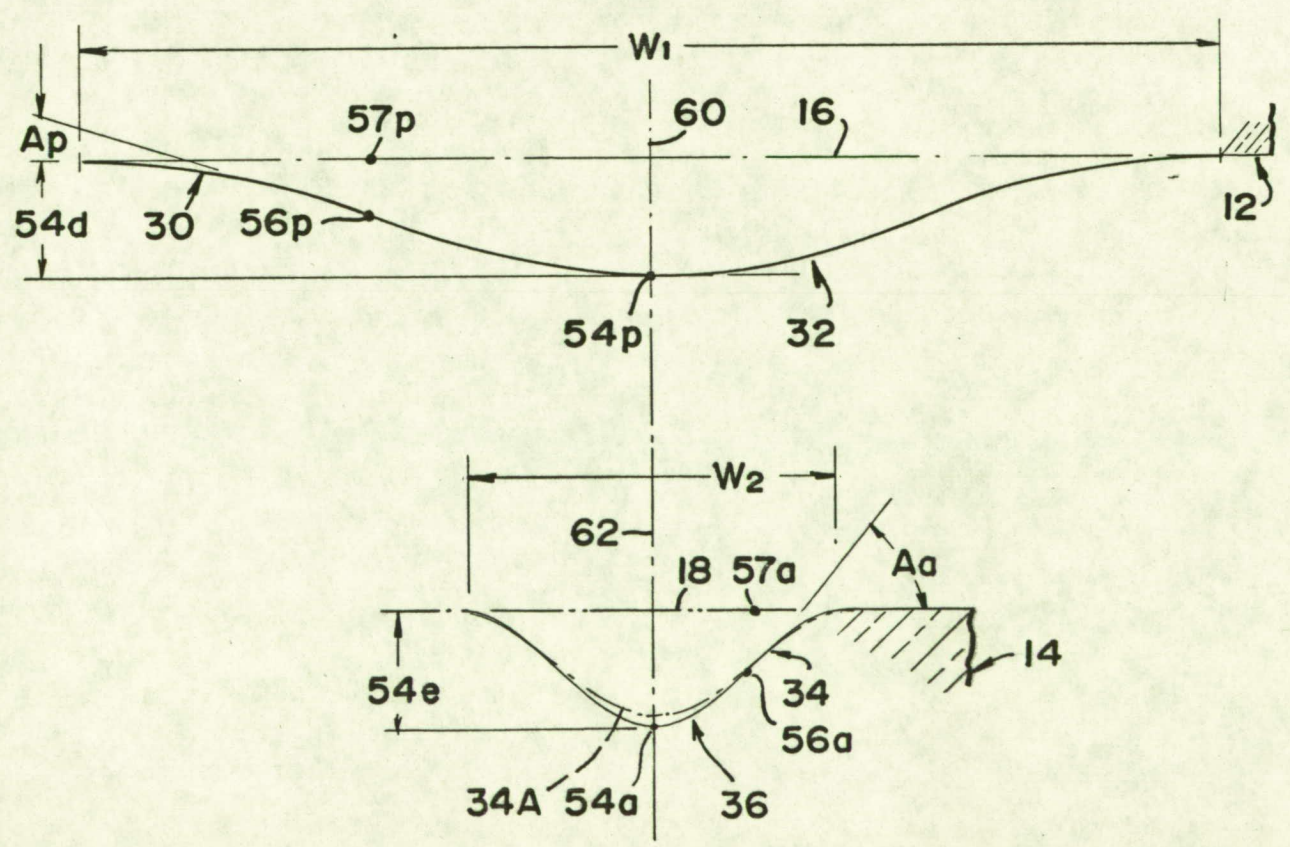

FIG. 4

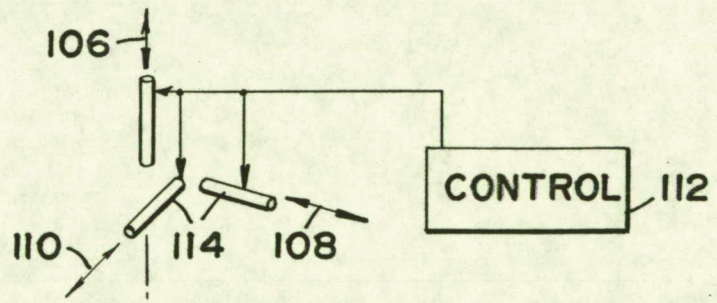
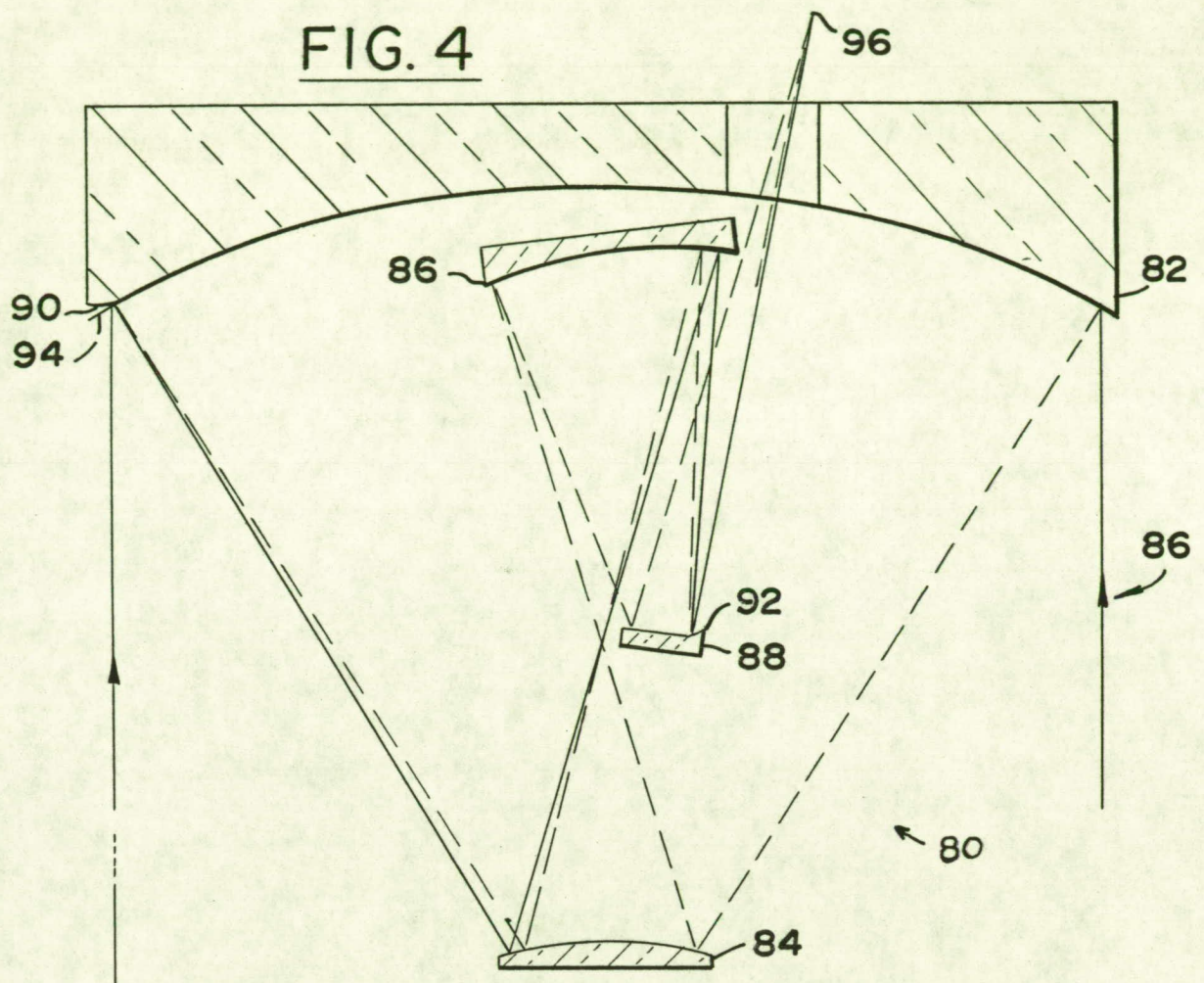
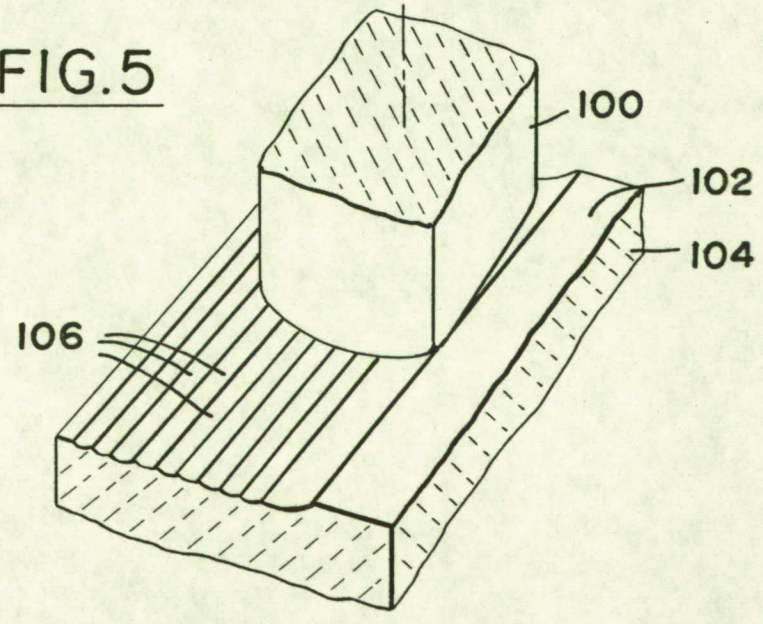

FIG. 5



JPL Case No. 16869
NASA Case No. NPO-16869-1-CU

Serial No.	867 986	
Filing Date	5/29/86	
Contract No.	86/158	
Contractor	Caltech/JPL	
Pasadena	CA.	91109
(City)	(State)	(Zip)

COMPENSATION FOR PRIMARY REFLECTOR WAVEFRONT ERROR

ORIGIN OF THE INVENTION

The invention described herein was made in the performance of work under a NASA contract, and is subject to the provisions of Public Law 96-517 (35 USC 202) in which the Contractor has elected not to retain
5 title.

BACKGROUND OF THE INVENTION

A large telescope can include a large primary mirror or reflector and additional reflectors and/or lenses, for directing light from a distant object in front of the primary reflector onto an image plane at a
10 focus. If the actual surface of the primary reflector deviates from the ideal surface, then light will not be accurately focused at the image plane. An ideal surface is one which, together with other ideal surfaces in the telescope, will bring on-axis rays of
15 light (or other electromagnetic radiation for which it is designed) from the distant object accurately to the focus. Techniques are available for readily determining the deviation of an actual reflector surface from an ideal one. However, it is very
20 expensive to form the surface of a very large primary reflector, having a diameter of more than one meter, so objects separated by a fraction of an arc second are clearly separated at the focus. It would be easier to form the other, smaller optical elements of the
25 telescope to compensate for regions of the primary reflector which deviate from the ideal primary reflector surface. However, it has heretofore been

very difficult to calculate precisely what changes in other elements of the telescope, or additional elements, will correct the error in the primary reflector without creating additional errors. A
5 relatively simple telescope system which enables correction for errors in the primary reflector, would facilitate the construction of high precision telescopes with large primary reflectors. Such corrections could be applied to electromagnetic imaging
10 systems for a wide range of wavelengths.

SUMMARY OF THE INVENTION

In accordance with one embodiment of the present invention, a telescope or similar instrument is provided wherein a deviation of the primary reflector is compensated for. The telescope includes means for
15 forming an image of the primary reflector onto a smaller auxiliary reflector of the telescope, so each point on the auxiliary reflector surface corresponds to a point on the primary reflector surface. The auxiliary reflector is formed with a deviation from an
20 ideal auxiliary reflector surface, which is conjugate to the deviation of the primary reflector surface from an ideal primary reflector surface. The conjugate deviation is such that each point on the auxiliary reflector surface has a piston shift equal but opposite
25 to the corresponding point on the primary reflector surface.

The novel features of the invention are set forth with particularity in the appended claims. The invention will be best understood from the following
30 description when read in conjunction with the accompanying drawings.

BRIEF DESCRIPTION OF THE DRAWINGS

Fig. 1 is a simplified sectional view of a Gregorian telescope constructed in accordance with the present invention.

Fig. 2 is a simplified perspective view of the 5 telescope of Fig. 1.

Fig. 3 is an enlarged illustration of portions of the primary and auxiliary reflectors of Fig. 1.

Fig. 4 is a simplified sectional view of a modified Cassegrain telescope constructed in accordance 10 with the present invention.

Fig. 5 is a simplified perspective view showing one method for forming a deviation in a auxiliary reflector of Fig. 1.

DESCRIPTION OF THE PREFERRED EMBODIMENTS

15 Fig. 1 illustrates a Gregorian type of telescope 10 which includes a substantially paraboloid primary mirror or reflector 12 and a hyperboloid secondary or auxiliary mirror or reflector 14 in front of the primary reflector. If the primary and auxiliary 20 reflectors had ideal surfaces indicated at 16 and 18, then light from a distant object 20, such as a star in the field of view of the optical system, would be accurately focused at a focus 22. That is, on-axis rays such as 24 would be brought to the focus 22, while 25 off-axis rays such as 26 would be focused at other points on an image location which form a surface such as a plane which includes the focus 22. In this particular case, a film indicated at 28 is to be exposed, while in other cases an eyepiece or electronic 30 imaging device is in a position to enable viewing by an observer.

In the telescope of Fig. 1, the primary reflector has an actual surface 30 which is

approximately the same and coincident with the ideal surface 16, but the actual primary reflector surface 30 deviates from the ideal surface 16 over a deviation area 32. The deviation in the area 32 is sufficient to
5 seriously affect the image at the film 28. Applicant compensates for the deviation in the primary reflector by constructing the actual surface 34 of the auxiliary reflector so it deviates over an area 36 from the ideal auxiliary reflector surface 18. In addition, applicant
10 constructs the telescope to include an intermediate element 40 which serves as a means which forms an image of the actual primary reflector surface 30 onto the actual auxiliary reflector surface 34. (Actually, the actual and ideal surfaces are sufficiently close for
15 each reflector that it does not matter whether the intermediate element 40 forms an image of the actual or ideal primary surface onto the actual or ideal auxiliary surface). The lens 40 and mirror supports 41, 43 act as a means for directing light from the
20 ideal primary surface onto the ideal auxiliary surface along paths that carry the light precisely toward the focus. The lens 40 lies at a location where on-axis rays such as 24 and 72 from the ideal primary surface, cross, which is a distance in front of the primary
25 reflector equal to its focal length.

As a result of the intermediate element or lens 40 forming an image of the primary surface onto the auxiliary one, there is a one-to-one correspondence between each point on the auxiliary surface with a
30 point on the primary surface. It is therefore necessary only that each point on the actual auxiliary surface 34 at the deviation area 36 thereof, be positioned to direct an on-axis ray reflected from a corresponding point on the actual primary surface 30 so
35 it reaches the focus 22. In Fig. 1, if the ray 24 were

to strike the ideal primary surface 16, then that ray would pass along the ideal path portion 42 to the ideal auxiliary surface 18. The ray would then be reflected along the ideal path portion 44 to the focus 22.

5 Because of the deviation of the actual primary surface from the ideal one, the ray 24 will be reflected along an actual path portion 46. However, the lens 40 will direct the actual ray passing along the path portion 46 into the path portion 48. The ray will strike a point

10 on the actual auxiliary surface 34 which will direct the ray along an actual final path portion 50 which is substantially coincident with the ideal final path portion 44.

Applicant has found that the shape of the

15 actual surface 34 in the deviation area 36 thereof can be computed in a relatively simple manner. Fig. 3 illustrates the deviation areas 32 and 36 of the actual primary and auxiliary reflector surfaces, and shows them in relation to the corresponding ideal primary and

20 auxiliary surfaces 16, 18. Points such as 54p, 56p on the actual primary surface 30 correspond to the points such as 54a, 56a on the actual auxiliary surface. A light ray striking the primary surface point 54p will be directed onto the auxiliary surface point 54a. The

25 point 54p on the primary mirror has a piston deviation 54d from the ideal surface 16 as measured along an imaginary line 60 that is normal to the ideal surface. Applicant has found that a corresponding point 54a on the auxiliary surface should be positioned at a piston

30 distance 54e from the ideal auxiliary surface 18, as measured along a line 62 that is normal to the ideal auxiliary surface 18. Applicant has found that a precision correction is obtained by positioning the points so that the piston deviation 54e of the

35 auxiliary surface point equals the piston deviation 54d

of the corresponding primary surface point. The same equality should exist for all other corresponding pairs of points on the primary and auxiliary surfaces. While the piston deviations 54d, 54e are equal, they are 5 opposite in sign in that when the primary deviation 32 is positive (beyond the ideal surface 16), the auxiliary deviation is negative (below the ideal surface 18) and vice versa.

It may be noted that the diameter D_2 (Fig. 1) 10 of the image on the secondary or auxiliary mirror is a predetermined fraction of the diameter D_1 of the area on the primary mirror from which rays are received. In the drawing of Fig. 1, the ratio of D_1 to D_2 is 3, so the magnification M of the primary to the auxiliary 15 is $D_1/D_2 = 3$. Any point such as 54p on the primary surface, which is spaced a distance 54x from the axis 66 of the primary mirror (its axis of symmetry), corresponds to a point 54a on the auxiliary mirror which is spaced a distance 54y from the axis 68 (of 20 symmetry) of the secondary mirror, where $54x = 54y D_1/D_2$, or $54yM$. Where the axes of the primary and auxiliary mirrors are coincident, the points 54p and 54a lie in the same imaginary plane, on diametrically opposite sides of the mirror axes.

25 A point such as 56p (Fig. 3) on the actual primary surface extends at a slope or angle A_p with respect to the adjacent ideal primary surface 16 (actually with respect to an adjacent point 57p on the ideal surface where both points 56p, 57p lie on a 30 normal to the ideal surface). The corresponding auxiliary surface point 56a extends at a slope or angle A_a from its adjacent ideal surface 18 (at ideal surface point 57a), where $A_a = A_p M$ (in absolute value). In Figs. 1-3, where $M = 3$, the angle A_a is 35 three times as great as the angle A_p . In Fig. 1, the

angle "B" between the ideal ray path and the actual path portion following the intermediate lens 40 is three times the angle "a" between the ideal path and the actual path portion 46 prior to the lens. The fact 5 that the angle A_a in Fig. 3 is three times as great as the angle A_p , results in precise compensation for the increased angle produced by the intermediate lens 40. The result is that the actual light ray becomes coincident with the ideal light ray along their final 10 path portions leading to the focus.

For small deviations of the actual primary surface from the ideal one, the distance along the ideal path portion at 42 and the actual path which is the addition of the two path portions 46, 48, is 15 substantially the same. This results largely from the fact that the piston deviations between corresponding points such as 54p and 54a on the primary and auxiliary surfaces are equal and opposite.

It should be noted that there are secondary 20 effects arising from the above-mentioned error-correcting approach. One effect is that the actual light ray will be brought to a focus that is slightly in front of or behind the ideal focus. This effect is small for small deviations of the actual 25 primary reflector surface from the ideal. If it is desired to minimize this effect, this can be accomplished by refocusing the deviation area of the auxiliary reflector. In Fig. 3, this would involve slightly "flattening" the auxiliary surface, as to the 30 configuration indicated at 34A. Even with secondary effects minimized, the deviation such as 54e of a point on the actual auxiliary surface will be between 75% and 125% of the deviation 54d of a corresponding point on the primary surface, at locations such as 54p, 54e 35 where the deviations are greatest. Similarly, the

angle A_a will be between 75% and 125% of M times the angle A_p . Thus, the deviations of points on the auxiliary surface will be substantially equal to the deviations of corresponding points on the primary surface. In a typical case, the deviation 54e of a point such as 54a will be between 90% and 110% of the deviation of a corresponding point on the primary reflector surface.

Prior large primary mirrors can be readily formed close to the ideal surface, so corrections for primary surface deviations by corresponding auxiliary surface piston deviations results in minimal secondary effects. Since a major cost has arisen from correcting small errors, the correction technique of the present invention is useful in saving a considerable sum in correcting for small errors in large mirrors. It may be noted that the lens 40 does not affect light rays reflected from portions of the primary mirror where it is coincident with the ideal primary mirror, so the addition of the lens 40 does not greatly change the design of the telescope.

Fig. 4 illustrates another telescope 80 of the Cassegrain type. The telescope includes a concave, parabolic Cassegrain telescope primary mirror 82 which reflects electromagnetic radiation from a distant object in its field of view toward a convex hyperbolic secondary mirror 84 that is positioned in front of the primary. The secondary mirror reflects light to a tertiary concave mirror 86 which reflects the light to a quaternary or auxiliary mirror 88. The secondary and tertiary mirrors 84, 86 (which form an intermediate optical element) form an image of the actual primary mirror or reflector surface 90 onto an actual surface 92 of the auxiliary reflector 88. Thus, every point on the actual auxiliary reflector surface 92 corresponds

to a point on the actual primary reflector surface 90. In Fig. 4, the actual primary surface 90 deviates from an ideal primary surface 94. The actual auxiliary surface 92 deviates from an ideal secondary surface 5 which, in conjunction with the ideal primary surface would form an image of on-axis rays of the object 20 at a focus 96. The actual auxiliary surface 92 deviates from the ideal auxiliary surface in that every point on the actual auxiliary surface has a piston deviation 10 substantially equal and opposite to the piston deviation of a corresponding point on the actual primary surface. It may be noted that a typical prior art Cassegrain telescope does not include mirrors at the positions of the tertiary and quaternary reflectors 15 86, 88, but instead includes a correcting lens or nothing at all.

In one system that has been designed for a 20 meter aperture size telescope similar to that of Fig. 4, the elements have the following characteristics:

20		RD	TM	CC
	<u>No. of surface</u>	<u>(radius of curvature)</u>	<u>(separation between surfaces)</u>	<u>(conic constant)</u>
	1 - primary	-24787.6	-11418.80	-0.987179
25	2 - secondary	- 2399.6	10831.27	-1.85967
	3 - tertiary	- 7614.1	- 5601.91	-0.772203
	4 - quaternary	-39910.6	8916.48	0.0

Where the units are in millimeters and "CC" stands for 30 "conic constant" which defines the surface. The surface deformation is:

$$z = \frac{r^2/R}{1 + \sqrt{1 - (CC + 1)(r/R)^2}}$$

Where Z is the deviation of each point on the ideal 35 surface from a plane normal to the surface axis, R is the radius of curvature of the corresponding point, and r is the radius, along an imaginary line that is normal

to the surface axis, from the surface axis to a point on the surface. The primary reflector 82 had a shape which was nearly that of a paraboloid, the secondary reflector 84 had the surface of a hyperboloid, the tertiary reflector 86 had the surface of an ellipsoid, and the auxiliary reflector had the surface of a flat mirror (except at the deviation area).

The auxiliary reflector can be constructed in a number of ways. Applicant has found that the construction can be obtained by the method indicated in Fig. 5, where a diamond cutting tool 100 moves across the surface 102 of a auxiliary reflector 104 to remove material therefrom in extremely fine cuts 106 which have a width which is a fraction of the wavelength of light reflected by the reflector. The diamond cutting tool 100 is controlled in its movements, indicated by arrows 106-110, by a computer control which energizes transducers 114.

The telescopes of the present invention are useful for reflecting electromagnetic radiation, sometimes herein referred to as light, of a wide range of wavelengths. The range includes ultraviolet and smaller wavelengths, through visible and infrared wavelengths, through microwave and radio wavelengths. For longer wavelengths, there previously has not been a problem in accurately forming the primary reflector surface. Therefore, the invention is especially useful for reflectors that are used for shorter wavelengths.

Although particular embodiments of the invention have been described and illustrated herein, it is recognized that modifications and variations may readily occur to those skilled in the art, and consequently, it is intended that the claims be interpreted to cover such modifications and equivalents.

COMPENSATION FOR PRIMARY REFLECTOR WAVEFRONT ERROR

ABSTRACT OF THE DISCLOSURE

In a telescope having primary and secondary reflectors, wherein the actual primary reflector surface deviates from an ideal primary reflector surface, such deviation is compensated for. At least
5 one intermediate element forms an image of the primary surface onto the secondary surface, so each point on the secondary surface corresponds to a point on the primary surface. The secondary surface is formed with a deviation from an ideal secondary surface, with the
10 "piston" distance of each point on the actual secondary surface equal to the piston distance of a corresponding point on the actual primary surface from the ideal primary surface. It is found that this results in electromagnetic (e.g., light) rays which strike a
15 deviating area of the actual primary surface being brought to the same focus as if the actual primary surface did not have a deviation from an ideal primary surface.