

# NASA Technical Memorandum 87768

## SUMMARY OF LONGITUDINAL STABILITY AND CONTROL PARAMETERS AS DETERMINED FROM SPACE SHUTTLE COLUMBIA FLIGHT TEST DATA

{NASA-TM-87768) SUMMARY OF LONGITUDINAL  
STABILITY AND CONTROL PARAMETERS AS  
DETERMINED FROM SPACE SHUTTLE COLUMBIA  
FLIGHT TEST DATA (NASA) 25 p CSCL 01C

N87-10101

G3/08 Unclas  
44281

William T. Suit

August 1986



National Aeronautics and  
Space Administration

Langley Research Center  
Hampton, Virginia 23665

## SUMMARY

Extensive wind tunnel tests were conducted to establish the preflight aerodynamics of the Shuttle vehicle. The vehicle was designed and built using this data. In an effort to verify the preflight aerodynamics, a flight test program was established. Maneuvers were made and data taken at various angles-of-attack and Mach numbers throughout the descent flight envelope.

This paper presents the longitudinal short period aerodynamics of the space shuttle Columbia as determined from flight test data. These flight-determined results were compared with the preflight predictions. In spite of the scatter in the flight-determined parameters, the general trends of the parameters with Mach number led to the conclusion that with the exception of the control effectiveness in the vicinity of Mach=1, the preflight predictions were representative of the vehicle's short-period aerodynamics. The pitch RCS was found to be more effective than predicted.

## INTRODUCTION

The Space Shuttle vehicle has received one of the most extensive preflight analysis of any aircraft that has ever flown. Thousands of wind-tunnel hours went into its development and refinement. The description of the Shuttle aerodynamics that resulted from the wind-tunnel tests and the analytical studies is a detailed description of the aerodynamic characteristics of the Shuttle vehicle over a flight envelope covering a Mach number range from 27 to 0 (reference 1). In an effort to verify the preflight aerodynamics, a flight test program was established. The program was planned as an on-going process based on the analysis of measurement data from each succeeding flight. Since only a limited number of maneuvers could be performed during a given Shuttle descent, these were planned to examine different aspects of the Shuttle aerodynamics so that as much of the flight envelope as possible could be verified.

The difficulty with this plan-of-attack was that the types of maneuvers that could be performed, within the constraints of safety and that were allowed by the Shuttle flight control system, were not the best maneuvers for identifying the Shuttle aerodynamic parameters. However, since the maneuvers that were allowable represent the only data available for analysis, each data set was examined in extreme detail. The majority of the results shown herein were obtained by processing the test maneuvers with a Maximum Likelihood parameter extraction program. Also, where appropriate, selected runs were examined using analytical techniques. When these multiple analyses show similar results, the confidence in the values determined is increased.

This paper will represent the results of analyzing the longitudinal maneuvers from five Columbia flights. These results will be compared with those of reference 1, and the implications and significance of any differences will be discussed. Also, comments will be made as to the confidence in the parameter values obtained.

## SYMBOLS

$a_X, a_Y, a_Z$	acceleration measured along X, Y, and Z body axes, respectively, g units
b	wing span, m (ft)
$\bar{c}$	wing mean geometric chord, m (ft)
$F_X, F_Y, F_Z$	force along X, Y and Z body axes, respectively, N (lb)
g	acceleration due to gravity, m/sec <sup>2</sup> (ft/sec <sup>2</sup> )
$I_X, I_Y, I_Z$	moment of inertia about X, Y, and Z body axes, respectively, kg-m <sup>2</sup> (slug-ft <sup>2</sup> )
$I_{XZ}$	product of inertia, kg-m <sup>2</sup> (slug-ft <sup>2</sup> )
$l_t$	distance from airplane center of gravity to center of pressure of horizontal tail, m (ft)
$M_X, M_Y, M_Z$	rolling, pitching, and yawing moments, respectively, N-m (ft-lb)

m	mass, kg (slugs)
p, q, r	rate of roll, pitch and yaw, rad/sec or deg/sec
$\bar{q}$	dynamic pressure, N/m <sup>2</sup> (slug/ft <sup>2</sup> )
R	estimate of error covariance matrix
S	wing area, m <sup>2</sup> (ft <sup>2</sup> )
u, v, w	velocity along X, Y, and Z body axes, respectively, m/sec (ft/sec)
U	control vector
V	airplane total velocity, m/sec (ft/sec)
X <sub>i</sub>	matrix of measured states and input variables
X, Y, Z	body coordinate axes through airplane center of gravity
x(i)	state vector
y(i)	output vector
z <sub>i</sub>	measurement vector
$\alpha$	angle of attack, rad or deg.
$\beta$	angle of sideslip, rad or deg.
$\delta_e$	elevator deflection, rad or deg.
$\delta_{SB}$	speedbrake deflection, rad or deg.
$\theta, \phi$	pitch angle, roll angle, rad or deg.
$\theta$	parameter vector
$\rho$	air density, kg/m <sup>3</sup> (slug/ft <sup>3</sup> )
$\eta$	measurement noise vector
$\Delta$	perturbation in parameter vector
C <sub>m</sub>	pitching-moment coefficient, M <sub>Y</sub> /qS
C <sub>X</sub>	axial-force coefficient, F <sub>X</sub> /qS
C <sub>Z</sub>	normal-force coefficient, F <sub>Z</sub> /qS

$$C_{m_q} = \frac{\partial C_m}{\partial \frac{q\bar{c}}{2V}} \quad C_{m_\alpha} = \frac{\partial C_m}{\partial \alpha} \quad C_{m_{\delta_e}} = \frac{\partial C_m}{\partial \delta_e} \quad C_{X_\alpha} = \frac{\partial C_X}{\partial \alpha}$$

$$C_{Zq} = \frac{\partial C_Z}{\partial \frac{qc}{2V}} \quad C_{Z\alpha} = \frac{\partial C_Z}{\partial \alpha} \quad C_{Z\delta_e} = \frac{\partial C_Z}{\partial \delta_e}$$

**Subscripts:**

C	computed
K	index
m	measured
o	coefficient at trimmed conditions
t	trimmed conditions
RCS	forces in moments due to Reaction Control System (RCS)
AERO	moments due to aerodynamic parameters
I	inertial moment

**Superscripts:**

-1	inverse matrix
T	transpose matrix
M	measured quantity
O	nominal evaluation
^	estimated value

A dot over a symbol signifies a derivative with respect to time.

### TEST VEHICLE

The orbiter configuration is shown as figure 1, and key physical characteristics are given in Table I. The thick, double delta wing is configured with full span elevons, comprising two panels per side. Each elevon panel is independently actuated. All four panels are deflected symmetrically as an elevator ( $\delta_e$ ) for pitch control and left and right elevons are deflected differentially as an aileron ( $\delta_a$ ) for roll control.

The body flap is used as the primary longitudinal trim device. The elevons are programmed to follow a set schedule with the body flap deflection to provide a desired aileron effectiveness.

The vertical tail consists of the fin and split rudder. The rudder panels are deflected together for yaw control and are separated to act as a speedbrake ( $\delta_{SB}$ )

to provide for subsonic energy modulation. The speedbrake opens fully (87.2 degrees) just below Mach 10 and then follows a predetermined schedule until Mach 0.9 is reached. The rudder is not activated until until Mach 3.5.

Stability augmentation is provided by the aft reaction control system (RCS) jets, with the forward jets reserved for on-orbit attitude control and for aborts. The aft yaw jets are active until Mach 1, while the pitch and roll jets are terminated at dynamic pressures of 20 and 10 psf, respectively. Additional details on the Shuttle vehicle and its systems are given in reference 1.

### **MANEUVERS**

During STS-2 through 5 and STS-9, specially designed maneuvers were performed to obtain data for use in the parameter extraction programs. These maneuvers were performed to obtain data at specific points during the descent trajectory. The test points were chosen so that aerodynamic parameters could be determined along the descent trajectory to verify the aerodynamic model obtained from the wind tunnel tests. This verification procedure will add confidence to the assumed aerodynamics of the Shuttle where there is agreement and will point to areas of potential inaccuracy where there is no agreement.

The actual forms of the inputs to be performed were developed using a Shuttle simulation to generate responses for various inputs and then extracting parameters from these responses. The control inputs that gave the best definition of the parameters of interest were then used for the flight tests. In spite of the care taken to design effective inputs, since the automatic control system was active, the controls were coupled and the resulting responses were reduced in magnitude and correlated with each other and the control inputs. This led to identifiability problems and correlation of parameters during the extraction process. Additional details on the maneuver design are given in reference 2.

### **INSTRUMENTATION AND DATA PROCESSING**

As a development vehicle, the Shuttle is fully instrumented and has a number of redundant systems for measuring various vehicle states and controls. Three instrument packages will be mentioned specifically. First is the Aerodynamic Coefficient Identification Package (ACIP), an instrumentation package specifically designed to measure rates, accelerations and control surface positions required for parameter identification. The ACIP data were recorded at 172 samples-per-second. Second is the instrumentation for the flight guidance and control system (RGA, AA) which is a source for acceleration and rate measurements. The RGA, AA data were recorded at 25 samples-per-second, but are very noisy. The third source of flight measurements is the navigation instrumentation (IMU). The IMU measurements are high fidelity, but are only recorded at one sample-per-second, which limited their usefulness.

With the exception of STS-2, where data were not available because of a recorder failure, the ACIP data were the primary source for the linear and angular accelerations, angular rates, and control surface deflections. The RCS chamber pressures were used to determine the jet thrust, and these measurements came from the vehicle operational instrumentation.

The data considered most reliable were used to generate a best estimated trajectory (BET) for the Shuttle vehicle. The data put on the tapes prepared for

parameter extraction consisted of only those maneuvers considered appropriate for extraction. The linear and angular accelerations, angular rates and control surface deflections came from the ACIP instrumentation except for STS-2 where a combination of IMU and RGA, AA data was used. The BET angular rates and linear accelerations at the start of a maneuver were taken as initial conditions, and the rates and accelerations were integrated over time to obtain angular positions and vehicle velocities. The velocities were then corrected for the effect of winds and the resulting components were used to calculate the vehicle total velocity, angle-of-attack and angle-of-sideslip. This combined data set comprises the data contained on the tape to be processed by the parameter extraction program, and is recorded at 25 samples-per-second. Additional details on the instrumentation and data processing can be found in references 3, 4, and 5.

### EXTRACTION METHODS

Several methods were used to estimate stability and control parameters using the flight test data. These were a maximum likelihood technique described in reference 6, a regression technique described in reference 7, and two analytical techniques described in references 8 and 9. The Maximum Likelihood technique utilizes the log-likelihood function

$$J(\theta) = -\frac{1}{2} \sum \eta_i^T R^{-1} \eta_i - \frac{N}{2} \log |R|$$

where

$$\eta_i = z_i - \hat{y}_i = y_i - y_i(\theta_0) - \frac{\partial y_i}{\partial \theta} \bigg|_{\theta = \theta_0} \Delta \theta$$

with  $z_i$  the measurement vector and  $y_i$  the output vector which comes from  $x=f(x, U, \theta, t)$  and  $y=g(x, U, \theta, t)$ . In the above equation  $\eta_i$  is assumed to have a Gaussian distribution and the representation  $x=f(x, U, \theta, t)$  is assumed to accurately represent the physical system. The unknowns to be estimated are the elements of  $\theta$  and  $R$ . Minimizing  $J$  with respect to  $R$ ,

$$\hat{R} = \text{diag} \frac{1}{N} \sum \eta_i \eta_i^T$$

is obtained. The estimates for the parameters are obtained from the equation

$$\frac{\partial J}{\partial \theta} \bigg|_{\theta = \hat{\theta}} = 0$$

which results in

$$\Delta \hat{\theta} = \left[ \sum_i \left( \frac{\partial y_i}{\partial \theta} \right)^T \hat{R}^{-1} \frac{\partial y_i}{\partial \theta} \right]^{-1} \left[ \sum_i \frac{\partial y_i}{\partial \theta} \hat{R}^{-1} \eta_i \right].$$

yielding the parameter estimates  $\theta = \theta_0 + \Delta \theta$ .

The regression technique utilizes the cost function

$$J_r(\theta) = \sum_{i=1}^N \left[ \dot{x}_{ri} - f_{ri}(x, U, \theta_r) \right]^2$$

where  $r$  indicates the  $r$ th state equation. The estimates of the unknown parameters

are obtained from the equation  $\frac{\partial J_r}{\partial \theta_r} = 0$  which results in

$$\hat{\theta} = \left[ \sum_i x_i^T x_i \right]^{-1} \left[ \sum_i x_i^T \dot{x}_{ri} \right]$$

where matrix  $x_i$  includes measured states and output variables (assumed noise free). Another feature of the stepwise regression program is that it estimates the parameters according to the percent of the vehicle motion explained by that particular parameter, identifying the most important parameters in the mathematical model. The parameter importance feature has worked reasonably well for the Shuttle data, but because of the reduced signal-to-noise ratio of the flight data, the parameters extracted using the regression program were biased in many cases.

Two analytical techniques were used to supplement the analysis of the Shuttle data using the extraction computer programs. One analytical technique was used to determine the longitudinal static parameters. Assuming that angular rates were constant,

$$C_m \Big|_{\alpha} \approx -C_{m\delta e} \delta_e$$

and

$$C_L \Big|_{\alpha} = \frac{W}{qS} a_z - C_{L\delta e} \delta_e$$

(where  $C_m$ ,  $C_L$  and the states are determined for a particular angle-of-attack ( $\alpha$ )) were used to calculate  $C_m$  and  $C_L$  for specific angle-of-attack values. Then as angle-of-attack varied, so did  $C_m$  and  $C_L$ . These variations were used to calculate  $\Delta C_m / \Delta \alpha$  and  $\Delta C_L / \Delta \alpha$ .

Another analytical technique used was deterministic analysis. The form of the equation used is:

$$\text{Vehicle total moment} = \text{RCS moment} + \text{aerodynamic moment} + \text{unmodeled moment.}$$

The deterministic equations can be written for moments about any of the vehicle body axes. The relative magnitudes of the terms that make up the aerodynamic moments indicated which of the aerodynamic parameters have the most influence on the vehicle total moment. The extent of the match of shape and magnitude between the aerodynamic moment and the vehicle total moment is an indication of how well the assumed mathematical model will represent the measured vehicle motion.

### EQUATIONS OF MOTION

The equations used in this program are perturbation equations from trimmed level flight and are written relative to the set of body axes shown in figure 1.

The equations used to describe the longitudinal motions were

$$\dot{u} = -qw + rv - g \sin \theta + \frac{1}{2} \rho \frac{V^2 S}{m} \left[ C_{X,0} + C_{X_\alpha} (\alpha - \alpha_t) \right]$$



$$\dot{w} = -pv + qu + g \cos \theta \cos \phi + \frac{1}{2} \rho \frac{V^2 S}{m} \left[ C_{Z0} + C_{Z_\alpha} (\alpha - \alpha_t) + C_{Z_q} \frac{\dot{q}c}{2V} + C_{Z_{\delta e}} (\delta_e - \delta_{e,t}) \right]$$

$$\dot{q} = pr \frac{I_Z - I_X}{I_Y} + \frac{I_{XZ}}{I_Y} (r^2 - p^2) + \rho \frac{V^2 S c}{2I_Y} \left[ C_{m,0} + C_{m_\alpha} (\alpha - \alpha_t) + C_{m_q} \frac{\dot{q}c}{2V} + C_{m_{\delta e}} (\delta_e - \delta_{e,t}) \right]$$

$$\dot{\theta} = q \cos \phi - r \sin \phi$$

$$a_X = \frac{1}{g} (\dot{u} + qw - rv + g \sin \theta)$$

$$a_Z = \frac{1}{g} (\dot{w} + pv - qu - g \cos \theta \cos \phi)$$

$$V = \sqrt{u^2 + v^2 + w^2}$$

$$\alpha = \tan^{-1} \frac{w}{u}$$

$$\beta = \sin^{-1} \frac{v}{V}$$

$$M_{YI} = \dot{q} I_y - (I_Z + I_X) pr + (p^2 - r^2) I_{XZ}$$

$$M_{Y \text{ AERO}} = \bar{q} S c \left[ C_{m_\alpha} (\alpha - \alpha_t) + C_{m_q} \frac{\dot{q}c}{2V} + C_{m_{\delta e}} (\delta_e - \delta_{e,t}) \right]$$

## RESULTS AND DISCUSSION

The allowable inputs for parameter extraction maneuvers were small and so the data were marginal for use with the parameter extraction programs. Because of this, several methods of analysis were used in the hope that there would be agreement in the parameter values determined from several sources and this would add confidence to the results. The stepwise regression program was also tried as an analysis tool, but the response to input was so small that results using the regression program were not usable. Therefore, the analysis procedures actually used to examine the flight data were a Maximum Likelihood program and two analytical techniques.

Only a limited number of the longitudinal maneuvers were usable for parameter extraction. The push-over, pull-up maneuver or the pull-up, push-over maneuver proved to give the most consistent results and yield parameter values with the lowest estimated standard deviations. Even with this "best" maneuver, only  $C_{Z_\alpha}$ ,  $C_{m_\alpha}$ , and  $C_{m_{\delta e}}$  were identifiable.  $C_{Z_{\delta e}}$  was not considered identifiable since the extracted values exhibited considerable scatter, and the estimated

standard deviations were over 30 percent of the estimated parameter value. Therefore,  $C_{Z\delta_e}$  was fixed at reference 1 values, except in the vicinity of Mach=1, for the runs shown in this paper. The parameter values chosen for  $C_{Z\delta_e}$  are given in the sections discussing the individual parameters.

The values determined for  $C_{Z\alpha}$ ,  $C_{m\alpha}$ , and  $C_{m\delta_e}$  are given in Table II for various Mach numbers. The estimated standard deviations are also given in the table. These values are an indication of confidence in the extracted parameter value. An estimated standard deviation that is less than one-tenth of the value of the estimated parameter indicates some confidence that the estimated parameter is reasonable. The parameters values for  $C_{Z\alpha}$ ,  $C_{m\alpha}$ ,  $C_{m\delta_e}$ , and  $C_{Z\delta_e}$  are plotted versus Mach number. There are two plots on each figure, one for Mach > 5 and one for Mach < 5. The individual parameters will now be discussed.

$C_{Z\alpha}$  - The variation of normal force coefficient with angle-of-attack parameter is shown plotted versus Mach number as figure 2. Examination of the figure indicated a trend toward values that were more negative than those of reference 1 for Mach 10 and above. Below Mach 10, extracted values of  $C_{Z\alpha}$  tend to be less negative than those of reference 1. In this lower Mach range, several parameter values are shown at the same Mach numbers. Because  $C_{Z\delta_e}$  was not considered identifiable from the runs available, selected values were used for this parameter in the vehicle mathematical model. Using reference 1 values for Mach numbers above 2 resulted in reasonable values for the other parameters. However, between Mach 1 and Mach 2, reference 1 indicated a change in the value of  $C_{Z\delta_e}$  by a factor of 5. When these larger values were used in the extraction mathematical model, the values for the other extracted parameters showed greater scatter and in some cases had unreasonable magnitudes. Because the reference 1 values for  $C_{Z\delta_e}$  resulted in unreasonable values for  $C_{m\alpha}$  and  $C_{Z\alpha}$ ,  $C_{Z\delta_e}$  values in the .4 per radian to .6 per radian range were chosen (see figure 5).

The values calculated for  $C_{Z\alpha}$ , using analytical techniques and assuming linear variations in alpha, "Z"-body acceleration and elevon deflection and pitch rate constant are also shown on figure 2. These values generally showed trends similar to those of reference 1. Below Mach 7 the magnitude of the values calculated for  $C_{Z\alpha}$  tended to be less negative than those of reference 1. In most cases, the calculated values showed the same trends as the values determined using the maximum likelihood extraction program.

$C_{m\alpha}$  - The static stability parameters for the flights discussed in this paper, plotted versus Mach number, are shown as figure 3. The values from reference 1 are designated by a solid line. Especially at the higher Mach numbers, there are many regions where  $C_{m\alpha}$  changes by 40 to 50 percent in a very small range of Mach numbers. These abrupt variations make comparing trends and values between the extracted  $C_{m\alpha}$  values and those of reference 1 difficult. In general, the extracted parameters seemed to show less static stability above Mach 10 and more below Mach 10 than the preflight predictions.

The values of  $C_{m\alpha}$  calculated using analytical techniques for the regions of the trajectory where alpha, "Z"-body accelerations and elevon deflection changes were linear and pitch rate was constant showed trends and magnitudes of the parameter values that were similar to those of the parameters extracted using the Maximum Likelihood program. This agreement tended to give additional confidence to the validity of the values determined.

$C_{m\delta_e}$  - The control effectiveness parameter is plotted versus Mach number and shown as figure 4. The values determined using the Maximum Likelihood extraction program generally showed the same trend but slightly less effectiveness than reference 1 down to Mach 5. Below Mach 5 the extracted parameters showed similar trends, but some of the values determined were different. The predominant feature in the preflight longitudinal aerodynamics is the abrupt change in the parameter values between Mach 1.5 and .5. In the case of  $C_{m\delta_e}$  the effectiveness is predicted to increase by a factor of 3 in the vicinity of Mach 1. Because of lack of maneuvers that would yield identifiable parameters during this part of the flight, this variation in effectiveness could not be verified. The trends of the extracted parameter values seemed to imply an increased effectiveness, but not as great an increase as predicted by reference 1.

$C_{Z\delta_e}$  - The variation of force along the "Z"-body axis with elevon deflection parameter from reference 1 and fixed values used for extraction of other parameters are plotted versus Mach number in figure 5. Above Mach 2 the values from reference 1 were used for  $C_{Z\delta_e}$ . However, below Mach 2 the plotted values seemed to give more realistic values for  $C_{Z\alpha}$ ,  $C_{m\alpha}$ , and  $C_{m\delta_e}$ .

At Mach=.7 the results from the maneuvers were not as sensitive to variations in  $C_{Z\delta_e}$  as those of Mach=.6 and Mach=.8. When  $C_{Z\delta_e}$  was set at the value from reference 1,  $C_{m\alpha}$  became significantly positive, but  $C_{Z\alpha}$  had a very reasonable value. When  $C_{Z\delta_e}$  was set at -.4 per radian  $C_{m\alpha}$ ,  $C_{Z\alpha}$  and  $C_{m\delta_e}$  did not vary significantly, however, the values extracted for  $C_{m\delta_e}$  showed much less control effectiveness than was expected.

The pitch jets on the Shuttle were only active for dynamic pressures less than 20 psf. The evaluation of the effectiveness of the pitch jets was made using several methods so that the values obtained could be verified. Values for the pitch jet effectiveness were obtained at three Mach numbers or alternatively at three values of  $\bar{q}$ . Values were obtained using the Maximum Likelihood extraction program and deterministically from the equation

$$\dot{q} I_y - (I_z - I_x) p r - (r^2 - p^2) I_{xz} = K_Y M_Y + \frac{1}{2} \rho V^2 S \bar{c} [ C_{m\alpha} \alpha + C_{m\delta_e} \delta_e ]$$

where  $C_{m\alpha}$  and  $C_{m\delta_e}$  were obtained from reference 1. The results of this determination of jet effectiveness is shown as figure 6. The figure shows the percent effectiveness plotted against dynamic pressure. The two methods agreed within 10 percent, indicating a strong confidence in the results. The flight-derived values, however, are very different from the predicted values at the lower values of dynamic pressure but tend to agree better with the predicted values at the higher values of dynamic pressure.

The results show that the up-firing jets are about 15 percent more effective than the down-firing jets. This is a measure of pitch jet interactions, and it had been hoped that by working in the dynamic pressure regime near zero, the interactions due only to impingement could be determined. Then by comparing the results to pitch jet effectiveness and higher dynamic pressures, the flow field interactions could be separated from the impingement interactions. Results from this attempt were inconclusive because of instrumentation resolution at low dynamic pressures and by the fact that at 20 psf, when jets were cut off, the flow effects were poorly defined.

### CONCLUDING REMARKS

Longitudinal aerodynamic parameters were extracted from flight test data for five flights of the Space Shuttle Columbia. These parameter values were compared with the preflight predictions to try to determine how well the predictions described the Shuttle aerodynamics. In general, the values of the identifiable parameters exhibited trends with Mach numbers that were similar to those of reference 1. However, for most of the Mach range, the actual values were different.

The extracted values of  $C_{Z\alpha}$  were more negative than those of reference 1 for Mach numbers greater than 10 and less negative for Mach numbers less than 10. However, the correlation problems that resulted from the small magnitudes of the vehicle's response to inputs reduced the confidence in the low Mach number results.

The extracted values for  $C_{m\alpha}$  tended toward less static stability above Mach 5 than those of reference 1. Below Mach 5, the parameter values extracted from flight data agreed reasonably well with those of reference 1; however, lack of data prevented a good definition of the large variation in  $C_{m\alpha}$  around Mach 1.

The extracted values for  $C_{m\delta_e}$  seem to generally agree with those of reference 1 in the Mach 1.5 to Mach 20 range. In this range, the parameter was fairly well identified, lending some confidence to the values obtained. Above Mach 20, the parameter was not well identified, and considerable scatter was evident in the values determined. Below Mach 1.5, the values determined indicated less elevon effectiveness than predicted by reference 1. When the reference 1 values were used for  $C_{Z\delta_e}$  in the same Mach range,  $C_{Z\alpha}$  and  $C_{m\alpha}$  had unreasonable values. If the reference 1 values of  $C_{Z\delta_e}$  were cut in half, then the  $C_{Z\alpha}$  and  $C_{m\alpha}$  values were more reasonable.

The RCS pitch jet effectiveness determined from flight indicates that the pitch jets are approximately twice as effective as predicted over most of the range where they are active.

With the exception of control effectiveness in the vicinity of Mach=1, the majority of the flight conditions covered during the entry phase of the five Columbia flights analyzed, the agreement with the preflight predictions is close enough to conclude that these predictions are a reasonable representation of the vehicle's short period aerodynamics.

**TABLE I.- ENTRY PHYSICAL CHARACTERISTICS OF SPACE SHUTTLE ORBITER**

Mass propoerties (range for five flights):

Mass, kg . . . . . 91,917-100,309

Moments of Inertia (range for five flights):

$I_X$ , kg-m<sup>2</sup> . . . . . 1,171,428-1,313,633  
 $I_Y$ , kg-m<sup>2</sup> . . . . . 9,228,939-9,614,705  
 $I_Z$ , kg-m<sup>2</sup> . . . . . 9,584,958-10,031,878  
 $I_{XZ}$ , kg-m<sup>2</sup> . . . . . 205,832-223,189

Wing:

Reference area, m<sup>2</sup> . . . . . 249.91  
 Mean aerodynamic chord, m . . . . . 12.06  
 Span, m . . . . . 23.79

Elevon (per side):

Reference area, m<sup>2</sup> . . . . . 19.51  
 Mean aerodynamic chord, m . . . . . 2.30

Rudder (per side panel):

Reference area, m<sup>2</sup> . . . . . 9.30  
 Mean aerodynamic chord, m . . . . . 1.86

Body Flap:

Reference area, m<sup>2</sup> . . . . . 12.54  
 Mean aerodynamic chord, m . . . . . 2.06

TABLE II.- EXTRACTED PARAMETERS

Parameter	Maximum Likelihood			Maximum Likelihood			Maximum Likelihood		
	Value	Standard Deviation	Sensitivity	Value	Standard Deviation	Sensitivity	Value	Standard Deviation	Sensitivity
	M = 27			M = 27			M = 26		
$C_{Z\alpha}$	-2.35	---		-2.35	---		-2.35	---	
$C_{Z\delta e}$	0	---		0	---		0	---	
$C_{m\alpha}$	-.32	---		-.32	---		-.32	---	
$C_{mq}$	0	---		0	---		0	---	
$C_{m\delta e}$	-.20	.27		-.09	.0025		-.23	.005	
KY	.77	.008		.85	.0045		.75	.0086	
	Maximum Likelihood			Maximum Likelihood			Deterministic		
	M = 25			M = 20			M = 20		
$C_{Z\alpha}$	-2.35	---		-3.1	.018		-3.0		
$C_{Z\delta e}$	0	---		0	---		---		
$C_{m\alpha}$	-.32	---		-.11	.0004		-.13		
$C_{mq}$	0	---		0	---		---		
$C_{m\delta e}$	-.225	.002		-.27	.001		-.25*		
KY	.70	.008		0	---				

\*Assumed

TABLE II.- EXTRACTED PARAMETERS (CONTINUED)

Parameter	Maximum Likelihood			Deterministic			Maximum Likelihood		
	M = 17			M = 17			M = 14		
	Value	Standard Deviation	Sensitivity	Value	Standard Deviation	Sensitivity	Value	Standard Deviation	Sensitivity
$C_{Z\alpha}$	-3.08	.047		-2.5			-2.8	.024	
$C_{Z\delta e}$	-.2	---		---			-.2	---	
$C_{m\alpha}$	-.074	.0003		-.13			-.097	.0002	
$C_{mq}$	-2.2	---		---			-2.2	---	
$C_{m\delta e}$	-.144	.0017		-.286*			-.226	.001	
Parameter	Deterministic			Deterministic			Deterministic		
	M = 14			M = 11			M = 9		
	Value	Standard Deviation	Sensitivity	Value	Standard Deviation	Sensitivity	Value	Standard Deviation	Sensitivity
$C_{Z\alpha}$	-2.6			-2.6			-2.4		
$C_{Z\delta e}$	---			0			---		
$C_{m\alpha}$	-.11			-.12			-.12		
$C_{mq}$	---			0			---		
$C_{m\delta e}$	-.286*			-.25*			-.25*		

\*Assumed

TABLE II.- EXTRACTED PARAMETERS (CONTINUED)

Parameter	Maximum Likelihood			Maximum Likelihood			Maximum Likelihood		
	M = 14			M = 8.5			M = 7		
	Value	Standard Deviation	Sensitivity	Value	Standard Deviation	Sensitivity	Value	Standard Deviation	Sensitivity
$C_{Z\alpha}$	-3.0	.09		-4.5	.27		-1.63	.041	
$C_{Z\delta e}$	-.16	---		-2.5	---		-.3	---	
$C_{m\alpha}$	-.22	.007		-.33	.0086		-.065	.0002	
$C_{mq}$	-2.2	---		-2.2	---		-2.2	---	
$C_{m\delta e}$	-.214	.0031		-.16	.0022		-.2	.0012	
	Deterministic								
	M = 7			M = 7			M = 5		
Parameter	Value	Standard Deviation	Sensitivity	Value	Standard Deviation	Sensitivity	Value	Standard Deviation	Sensitivity
$C_{Z\alpha}$	-2.6			-1.8			-1.56		
$C_{Z\delta e}$	---			---			---		
$C_{m\alpha}$	-.036			-.074			-.10		
$C_{mq}$	---			---			---		
$C_{m\delta e}$	-.2*			-.2*			-.18*		

\*Assumed



TABLE II.- EXTRACTED PARAMETERS (CONTINUED)

Parameter	Maximum Likelihood			Maximum Likelihood			Maximum Likelihood		
	M = 2			M = 1.4			M = 1.5		
	Value	Standard Deviation	Sensitivity	Value	Standard Deviation	Sensitivity	Value	Standard Deviation	Sensitivity
$C_{Z\alpha}$	-1.9	.03		-1.6	.05		-2.3	.15	
$C_{Z\delta e}$	-.4	---		-.4	---		-.4	---	
$C_{m\alpha}$	-.22	.0005		-.21	.0009		-.32	.01	
$C_{mq}$	-2.2	---		-2.2	---		-2.2	---	
$C_{m\delta e}$	-.23	.0004		-.24	.0006		-.165	.007	
Parameter	Maximum Likelihood			Maximum Likelihood			Maximum Likelihood		
	M = .8			M = .7			M = .6		
	Value	Standard Deviation	Sensitivity	Value	Standard Deviation	Sensitivity	Value	Standard Deviation	Sensitivity
$C_{Z\alpha}$	-1.5	.16		-2.6	.24		-1.4	.18	
$C_{Z\delta e}$	-.6	---		-.4	---		-.4	---	
$C_{m\alpha}$	-.61	.006		-.10	.01		-.07	.03	
$C_{mq}$	-2.2	---		-2.2	---		-2.2	---	
$C_{m\delta e}$	-.44	.005		-.18	.005		-.48	.016	

\*Assumed

## REFERENCES

1. Aerodynamic Design Data Book - Volume I: Orbiter Vehicle. NASA CR-160386, 1978.
2. Cooke, D. R.: Space Shuttle Stability and Control Test Plan, AIAA Paper 82-1315, August 1982.
3. Findlay, J. T.; Kelly, G. M., and Henry, M. W.: An Extended BET Format for LaRC Shuttle Experimenters: Definitions and Development. AMA Report No. 81-11, NASA CR-165882, April 1982.
4. Findlay, J. T.; Kelly, G. M.; and McConnell, J. G.: An AERodynamic Best Estimate Trajectory File (AEROBET) for NASA Langley Research Center Shuttle Investigations. AMA Report No. 82-9, Control NAS1-16087, March 1982.
5. Flanagan, P. F.: FINAL REPORT/GTFILE Generation - Definition and Development. AMA Report No. 81-20, NASA P. O. L23695B, July 1981.
6. Suit, William T.; and Mayo, Marna H.: On Matching the Systems Identification Technique to the Particular Application. JACC, Charlottesville, VA, June 1981.
7. Klein, V.; Batterson, J. G.; and Murphy, P. C.: Determination of Airplane Model Structure from Flight Data by Using Modified Stepwise Regression. NASA TP-1916, October 1981.
8. Klein, V.: Determination of Longitudinal Aerodynamic Derivatives from Steady-State Measurement of an Aircraft. AIAA 4th Atmospheric Flight Mechanics Conference, Hollywood, Florida, August 8-10, 1977.
9. Suit, William T.; Compton, H. R.; Scallion, W. I.; and Schiess, J. R.: Simplified Analysis Techniques to Support the Determination of Shuttle Aerodynamics. AIAA-83-0117, AIAA 21st Aerospace Sciences Meeting, January 1983.

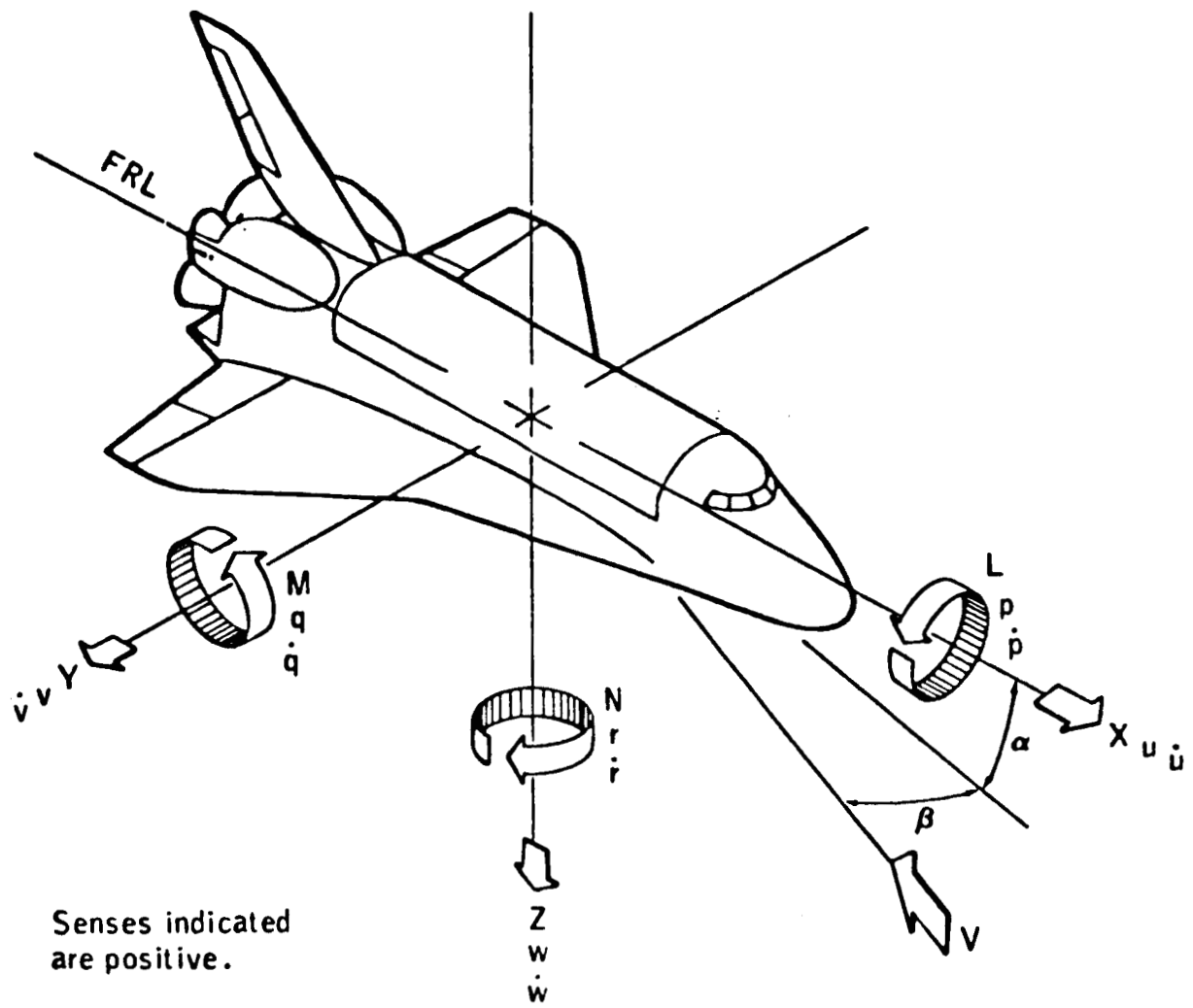

Figure 1.- Schematic of Shuttle vehicle showing body axes and positive senses of accelerations, rates, velocities, moments and angles.

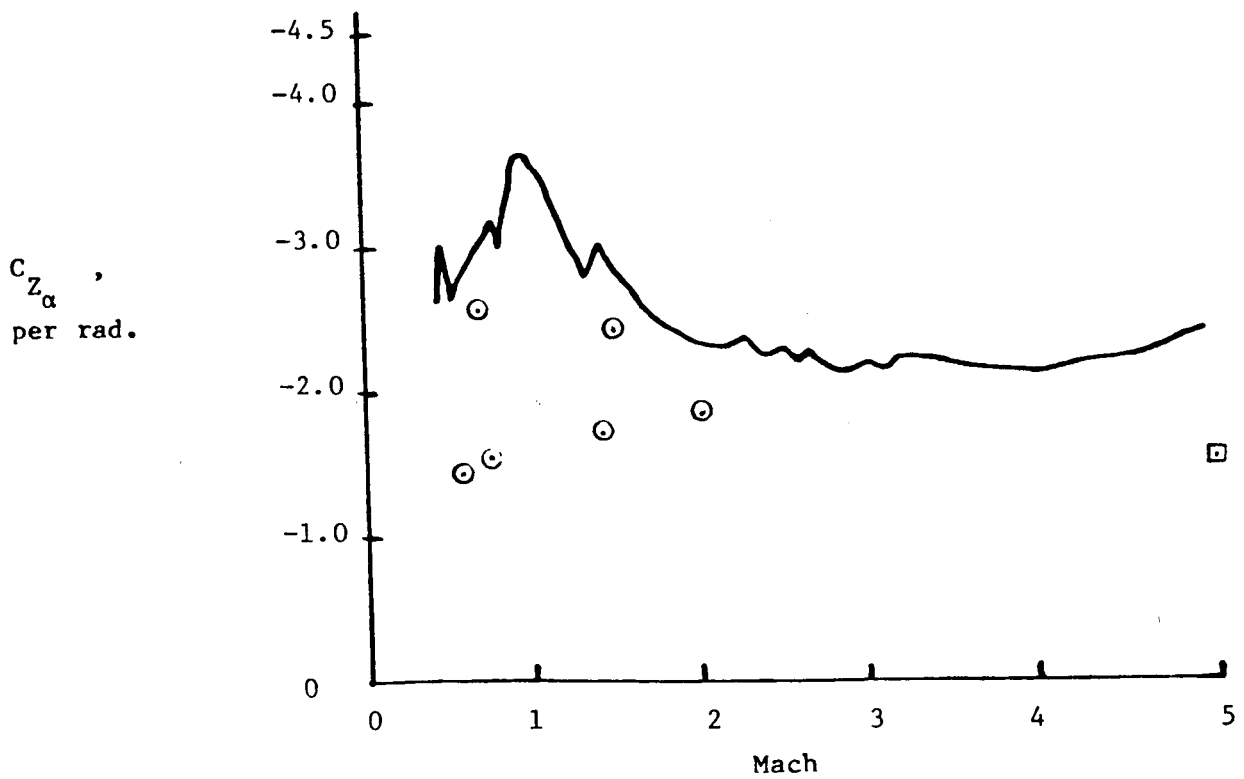
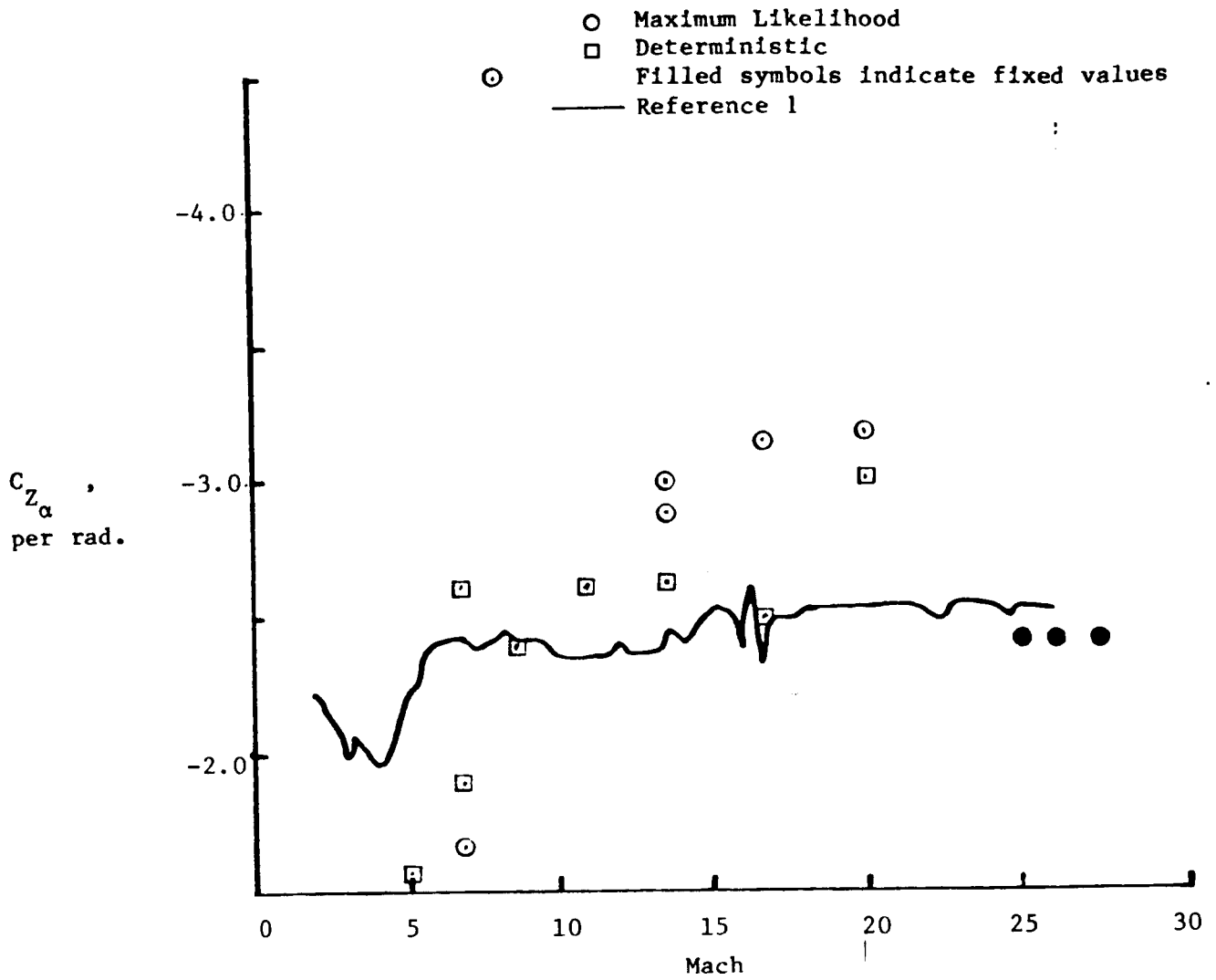

Figure 2.- Change in normal force with alpha versus Mach number.

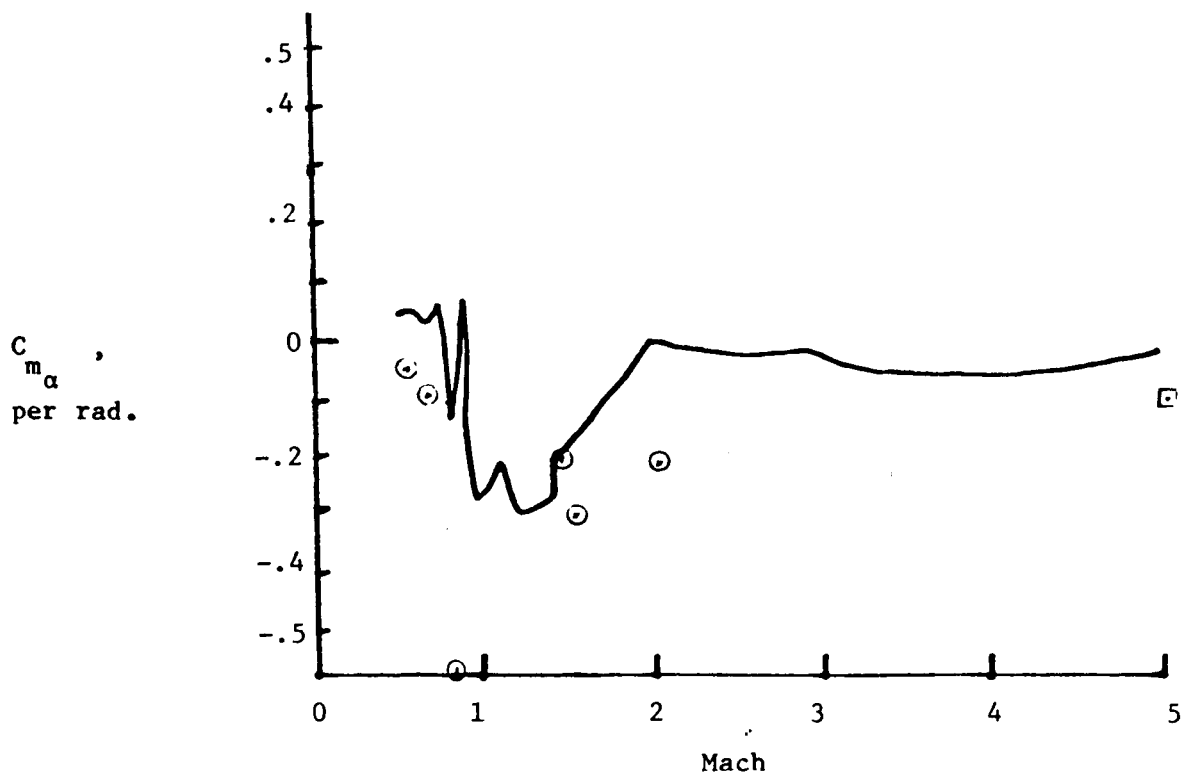
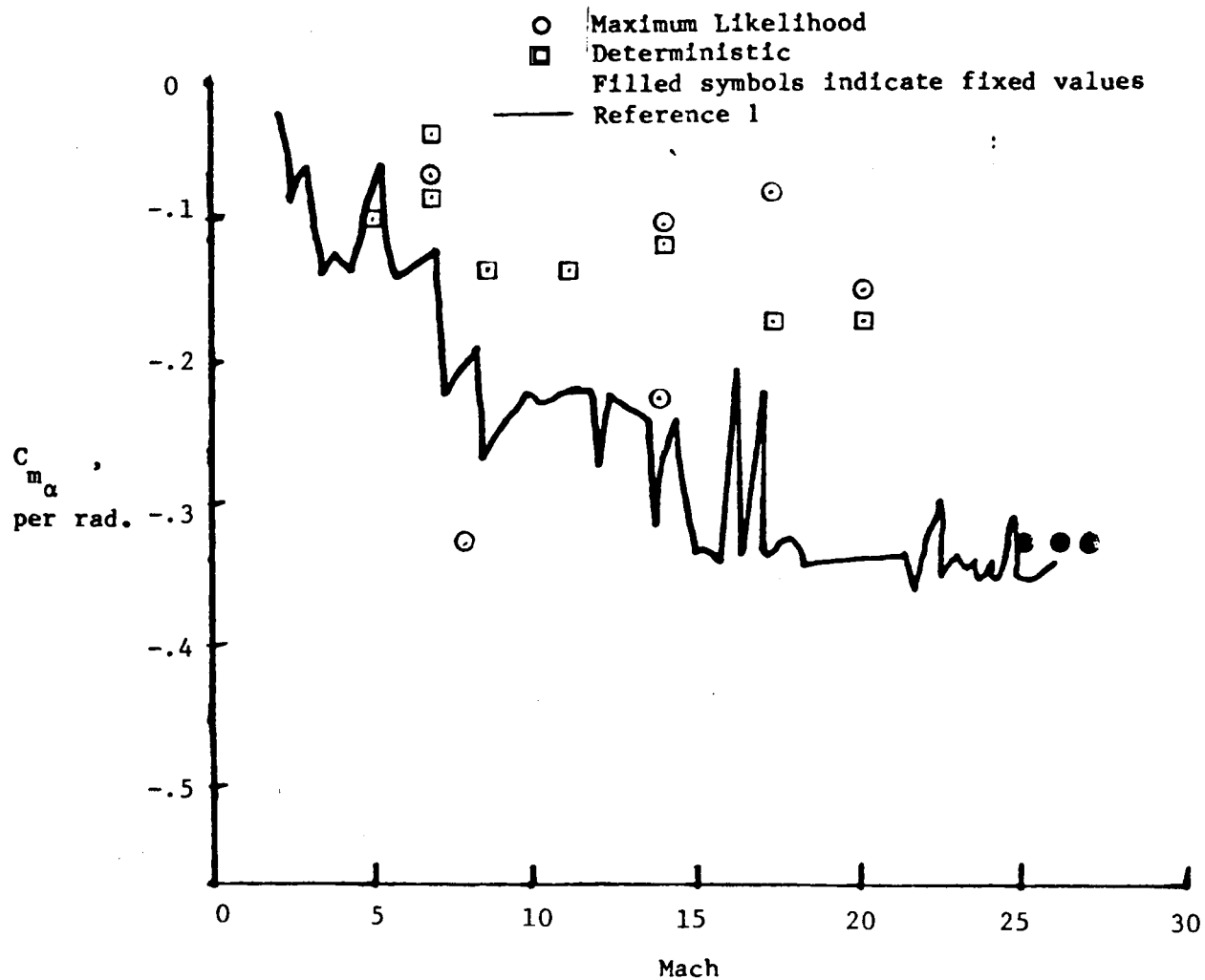

Figure 3.- Static stability versus Mach number.

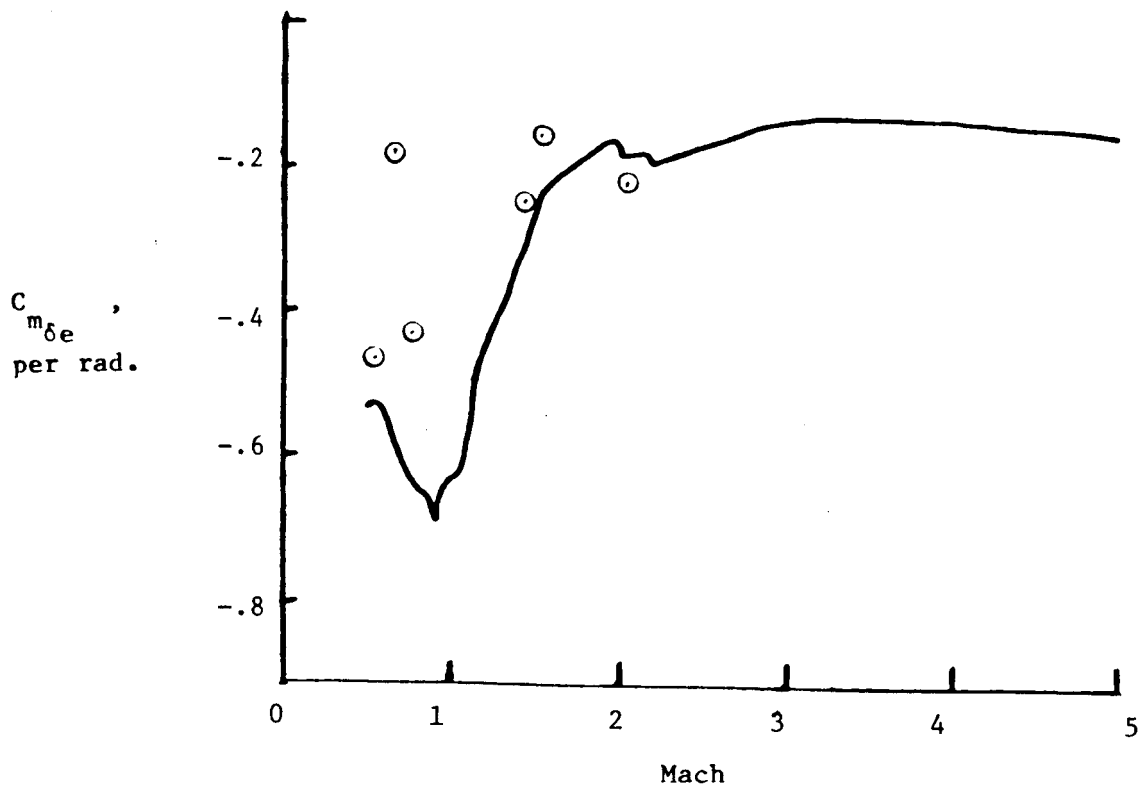
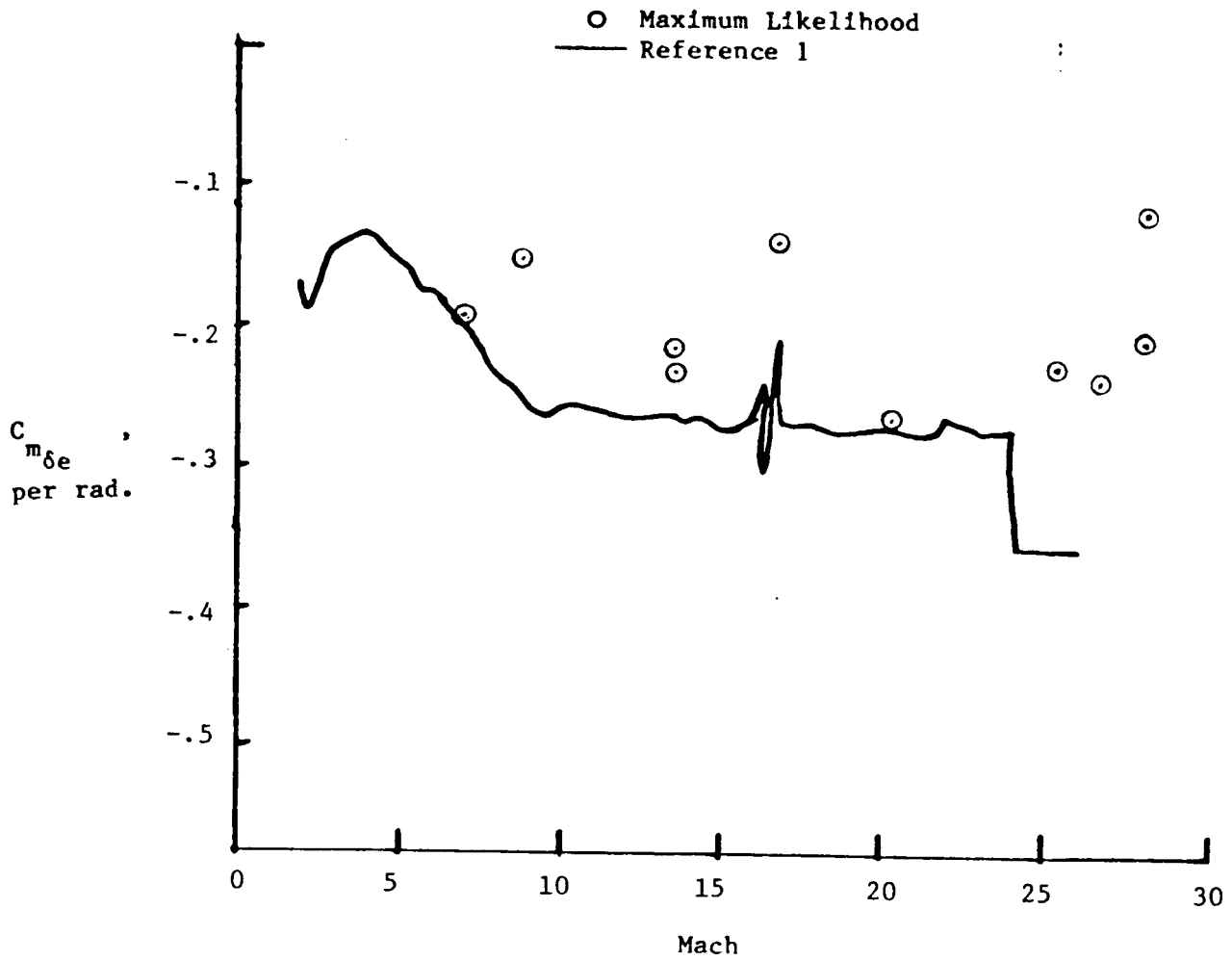

Figure 4.- Elevon effectiveness versus Mach number.

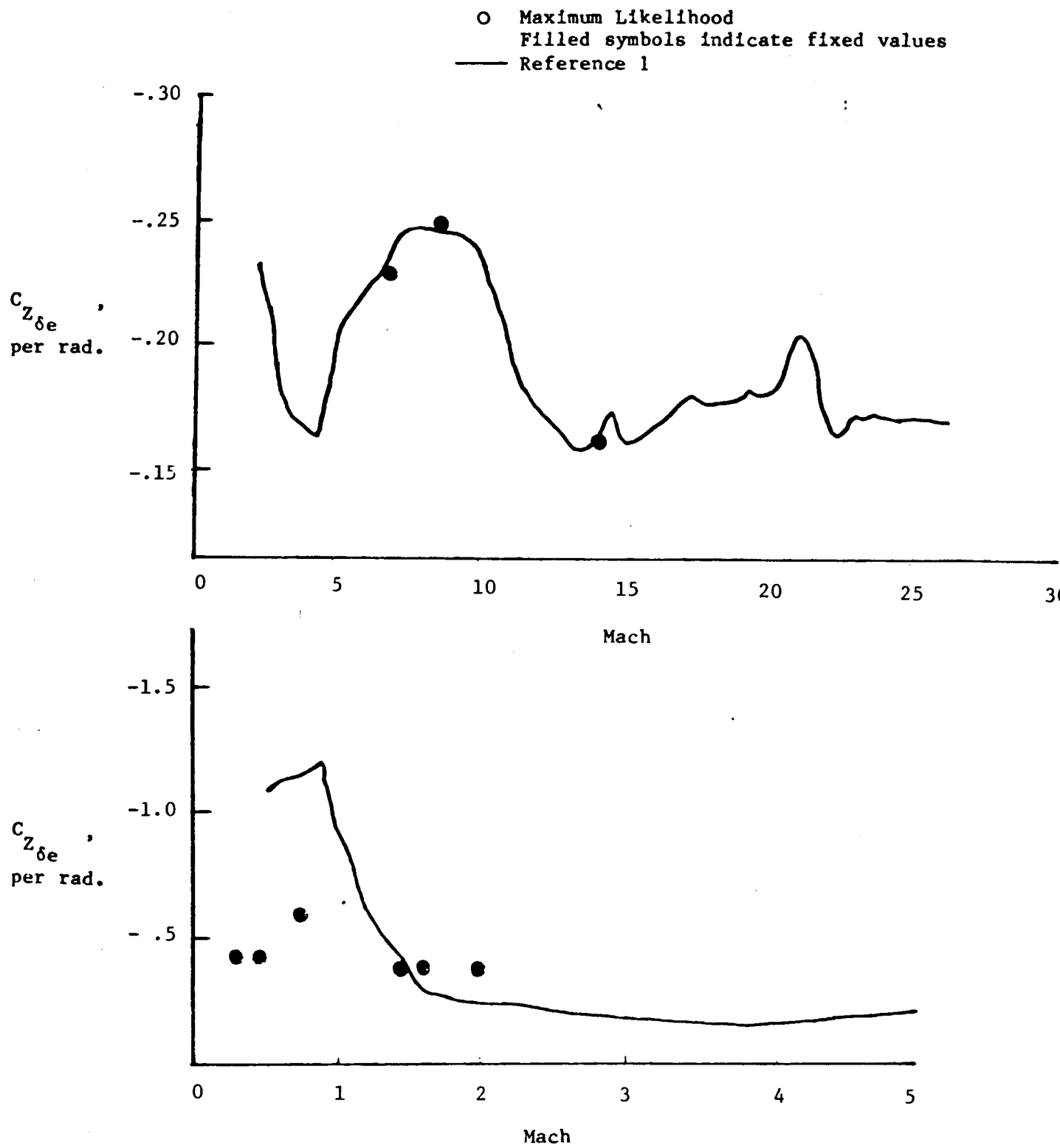

Figure 5.- Change in normal force with elevon deflection versus Mach number.

# RCS PITCH JET EFFECTIVENESS

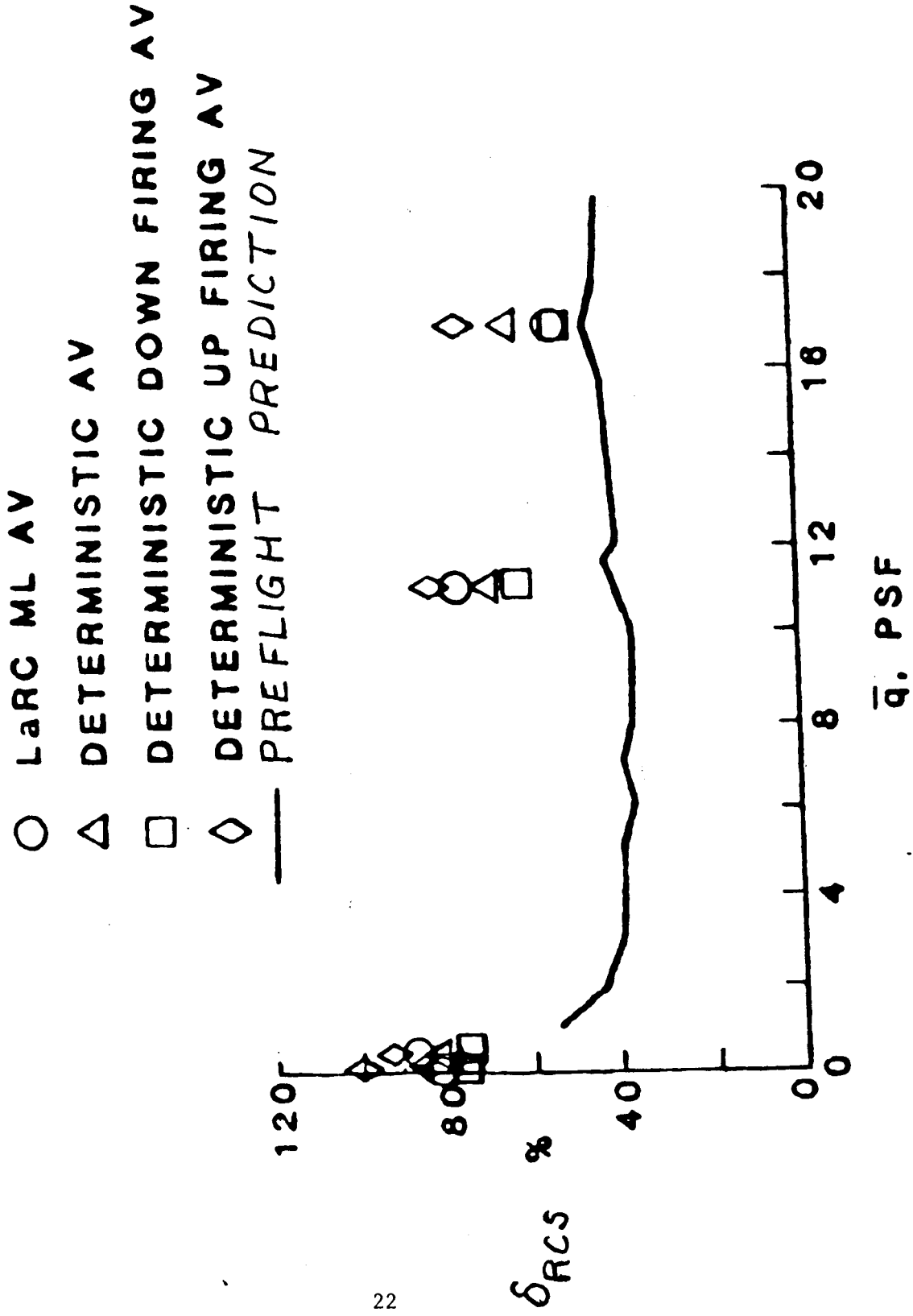

Figure 6.- Pitch jet effectiveness versus dynamic pressure.



1. Report No. NASA TM-87768		2. Government Accession No.		3. Recipient's Catalog No.	
4. Title and Subtitle SUMMARY OF LONGITUDINAL STABILITY AND CONTROL PARAMETERS AS DETERMINED FROM SPACE SHUTTLE COLUMBIA FLIGHT TEST DATA				5. Report Date August 1986	
				6. Performing Organization Code 506-46-21-01	
7. Author(s) William T. Suit				8. Performing Organization Report No.	
9. Performing Organization Name and Address NASA Langley Research Center Hampton, VA 23665				10. Work Unit No.	
				11. Contract or Grant No.	
12. Sponsoring Agency Name and Address National Aeronautics and Space Administration Washington, DC 20546				13. Type of Report and Period Covered Technical Memorandum	
				14. Sponsoring Agency Code	
15. Supplementary Notes					
16. Abstract  Extensive wind tunnel tests were conducted to establish the preflight aerodynamics of the Shuttle vehicle. This paper presents the longitudinal, short-period aerodynamics of the space shuttle Columbia as determined from flight test data. These flight-determined results are compared with the preflight predictions, and areas of agreement or disagreement are noted. In addition to the short-period aerodynamics, the pitch RCS effectiveness was determined.					
17. Key Words (Suggested by Author(s)) Parameter Estimation Stability and Control Parameters Maximum Likelihood			18. Distribution Statement Unclassified--Unlimited Subject Category--08		
19. Security Classif. (of this report) Unclassified		20. Security Classif. (of this page) Unclassified		21. No. of Pages 24	22. Price A02