

(NASA-CR-178904) GUIDEBOOK FOR ANALYSIS OF
TETHER APPLICATIONS Final Report (Energy
Science Labs., Inc.) 47 p
CSC1 22A

GUIDEBOOK FOR ANALYSIS OF TETHER APPLICATIONS

Joseph A. Carroll

Final Report on Contract RH4-394049
with the Martin Marietta Corporation
William Nobles, Technical Monitor
March 1985

G3/18
UNCLAS
44245

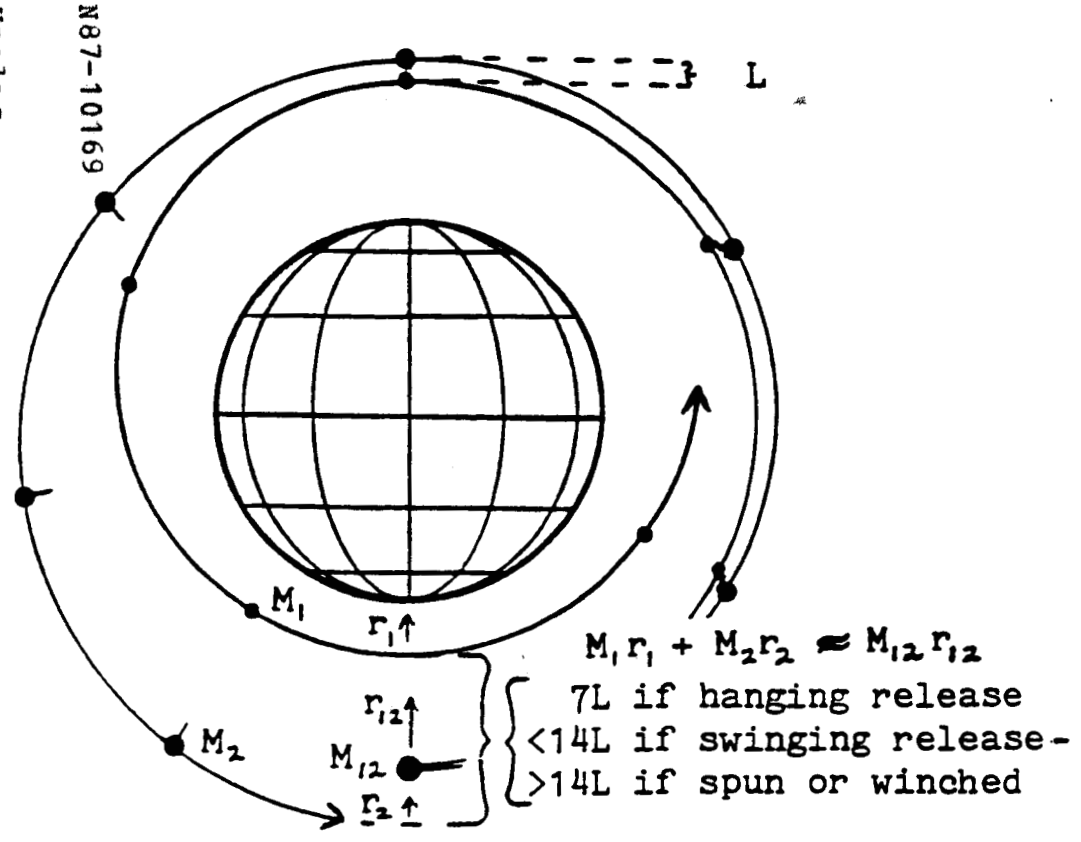

Effects of Tether Deployment and Release

PREFACE

Generic Issues

ORBIT BASICS

- Orbit Equations
- Perturbations
- Aerodynamic Drag
- Thermal Balance
- Micrometeoroids & Debris

TETHER DYNAMICS

- Gravity Gradients
- Dumbbell Libration
- Control Strategies
- Momentum Transfer
- Orbit Transfer
- Energy Balance

THE TETHER ITSELF

- Strength & Mass
- Impact Hazards

ELECTRODYNAMICS

- Basic Principles
- Orbit Changes
- Libration Control

BIBLIOGRAPHY

PREFACE

This Guidebook is intended as a tool to facilitate initial analyses of proposed tether applications in space. The guiding philosophy is that at the beginning of a study effort, a brief analysis of ALL the common problem areas is far more useful than a detailed study in any one area. Such analyses can minimize the waste of resources on elegant but fatally flawed concepts, and can identify the areas where more effort is needed on concepts which do survive the initial analyses.

In areas in which hard decisions have had to be made, the Guidebook is:

Broad, rather than deep
Simple, rather than precise
Brief, rather than comprehensive
Illustrative, rather than definitive

Hence the simplified formulas, approximations, and analytical tools included in the Guidebook should be used only for preliminary analyses. For detailed analyses, the references with each topic & in the bibliography may be useful. Note that topics which are important in general but not particularly relevant to tethered systems analysis (e.g., radiation dosages) are not covered.

CREDITS

This Guidebook was prepared by the author under subcontract RH4-394049 with the Martin Marietta Corporation, as part of its contract NAS8-35499 (Phase II of a Study of Selected Tether Applications in Space) with the NASA Marshall Space Flight Center. Some of the material was adapted from references listed with the various topics, and this assisted the preparation greatly. Much of the other material evolved or was clarified in discussions with one or more of the following: Dave Arnold, James Arnold, Ivan Bekey, Guiseppe Colombo, Milt Contella, Dave Criswell, Don Crouch, Andrew Cutler, Mark Henley, Don Kessler, Harris Mayer, Jim McCoy, Bill Nobles, Tom O'Neil, Paul Penzo, Jack Slowey, Georg von Tiesenhausen, and Bill Thompson. The author is of course responsible for all errors, and would appreciate being notified of any that are found.

Joseph A. Carroll
Energy Science Laboratories
11404 Sorrento Valley Rd, #113
San Diego, CA 92121
619-452-7039

Generic Issues in Various Tether Applications

MAJOR CONSTRAINTS IN MOMENTUM-TRANSFER APPLICATIONS

CONSTRAINT: APPLICATION:	ORBIT BASICS	TETHER DYNAMICS	TETHER PROPERTIES	TETHER OPERATIONS
All types	Apside location	Forces on end masses	μ meteoroid sensitivity	Tether recoil at release
Librating		Tether can go slack		Facility attitude & "g"s variable
Spinning		High loads on payload		Retrieval can be difficult
Winching		High loads on payload		Extremely high power needed
Rendezvous	Orbit planes must match			Short launch & capture windows
Multi-stage	Dif. nodal regression			Waiting time between stages
High deltaV	Gravity losses	Control of dynamics	Tether mass & lifetime	Retrieval energy; Facility Δ alt.

MAJOR CONSTRAINTS WITH PERMANENTLY-DEPLOYED TETHERS

CONSTRAINTS: APPLICATION:	ORBIT BASICS	TETHER DYNAMICS	TETHER PROPERTIES	TETHER OPERATIONS
All types	Aero. drag	Libration	Degradation, μ meteoroids & debris impact.	Recoil & orbit changes after tether break
Electrodynamic	Misc changes in orbit	Plasma disturbances	High-voltage insulation	
Aerodynamic	Tether drag & heating			
Beanstalk (Earth)			Tether mass; debris impact	Consequences of failure
Gravity Use: Hanging Spinning		Libr-sensitive		<.1 gee only. Docking awkward

KEY POINTS

Basic orbit nomenclature & equations are needed frequently in following pages. Comparison of tether & rocket operations requires orbit transfer equations.

The figures and equations at right are a summary of the aspects of orbital mechanics most relevant to tether applications analysis. For more complete and detailed treatments and many of the derivations, consult refs 1-3.

The first equation in the box is known as the Vis Viva formulation, and to the right of it is the equation for the mean orbital angular rate, n . Much of the analysis of orbit transfer ΔV s and tether behavior follows from those two simple equations. Some analyses require a close attention to specific angular momentum, h , so an expression for h (for compact objects) is also given here.

In general, six parameters are needed to completely specify an orbit. Various parameter sets can be used (e.g., 3 position coordinates & 3 velocity vectors). The six parameters listed at right are commonly used in orbital mechanics. Note that when $i=0$, Ω becomes indeterminate (and unnecessary); similarly with w when $e=0$. Also, i & Ω are here referenced to the central body's equator, as is usually done for Low Earth Orbit (LEO). For high orbits, the ecliptic or other planes are often used. This simplifies calculation of 3rd body effects.

The effects of small ΔV s on near-circular orbits are shown at right. The relative effects are shown to scale: a ΔV along the velocity vector has a maximum periodic effect 4 times larger than that of the same ΔV perpendicular to it (plus a secular effect in θ which the others don't have). Effects of oblique or consecutive ΔV s are simply the sum of the component effects. Note that out-of-plane ΔV s at a point other than a node also affect Ω .

NOTES

For large ΔV s, the calculations are more involved. The perigee and apogee velocities of the transfer orbit are first calculated from the Vis Viva formulation and the constancy of h . Then the optimum distribution of plane change between the two ΔV s can be computed iteratively, and the required total ΔV found. Typically about 90% of the plane change is done at GEO.

To find how much a given in-plane tether boost reduces the required rocket ΔV , the full calculation should be done for both the unassisted and the tether-assisted rocket. This is necessary because the tether affects not only the perigee velocity, but also the gravity losses and the LEO/GEO plane change split. Each m/s of tether boost typically reduces the required rocket boost by .89 m/s (for hanging release) to .93 m/s (for widely librating release).

Note that for large plane changes, and large radius-ratio changes even without plane changes, 3-impulse "bi-elliptic" maneuvers may have the lowest total ΔV . Such maneuvers involve a boost to near-escape, a small plane and/or perigee-adjusting ΔV at apogee, and an apogee adjustment (by rocket or aerobrake) at the next perigee. In particular, this may be the best way to return aerobraking OTVs from GEO to LEO, if adequate time is available.

REFERENCES

1. A.E. Roy, Orbital Motion, Adam Hilger Ltd., Bristol, 1978.
2. Bate, Mueller, & White, Fundamentals of Astrodynamics, Dover Pub., 1971.
3. M.H. Kaplan, Modern Spacecraft Dynamics & Control, John Wiley & Sons, 1976.

Orbit & Orbit Transfer Equations

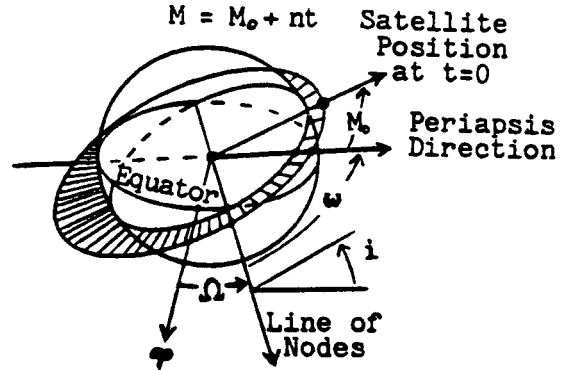
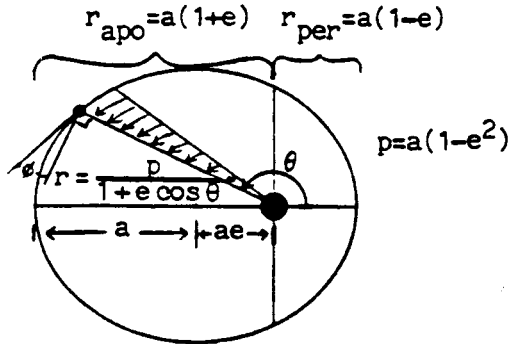

$v^2 = \mu \left(\frac{2}{r} - \frac{1}{a} \right)$	$n = \dot{\theta} = \sqrt{\mu/a^3}$
$v_{circ}^2 = \mu/r$	$h = \sqrt{\mu p} = r^2 \dot{\theta} = r v \cos \phi$
$v_{esc}^2 = 2\mu/r$	$\mu_{earth} = 398601 \text{ km}^3/\text{sec}^2$
	$\mu_x = G * \text{Mass of } x$

BASIC ORBIT EQUATIONS

ORBITAL ELEMENTS
a = semi-major axis
e = eccentricity
i = inclination
Ω = long. of asc. node
ω = argument of periapsis
M_0 = position at epoch

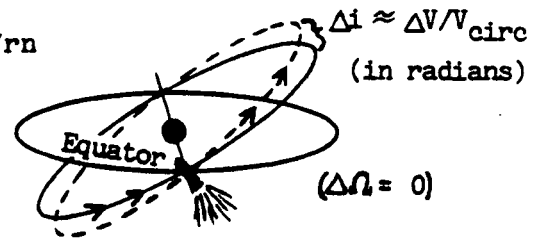
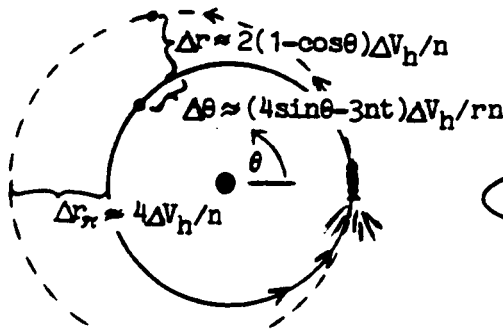
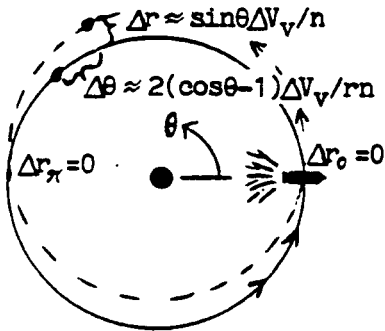

Effects of Small ΔV s on Near-Circular Orbits

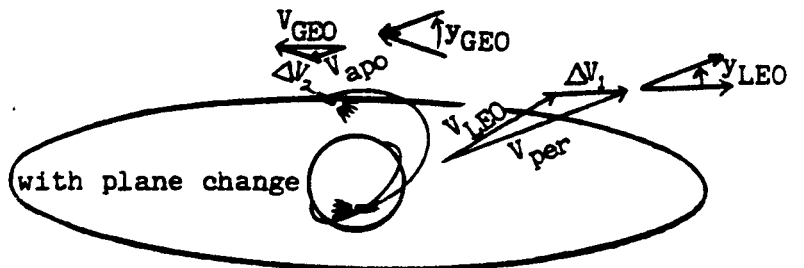
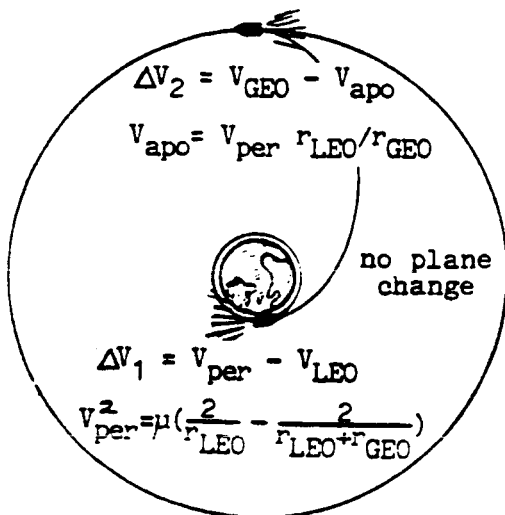

Total ΔV is minimized when $\frac{\sin \gamma_{LEO}}{\sin \gamma_{GEO}} = \frac{r_{LEO}}{r_{GEO}}$

Large Orbit Transfers (e.g., LEO—GEO)

KEY POINTS

Differential nodal regression severely limits coplanar rendezvous windows. Apsidal recession affects STS deboost requirements from elliptical orbits. Third bodies can change the orbit plane of high-orbit facilities.

The geoid (earth's shape) is roughly that of a hydrostatic-equilibrium oblate ellipsoid, with a 296:297 polar:equatorial radius ratio. There are departures from this shape, but they are much smaller than the 1:297 oblateness effect and have noticeable effects only on geosynchronous and other resonant orbits.

The focus here is on oblateness, because it is quite large and because it has large secular effects on Ω and w for nearly all orbits. (Oblateness also affects n , but this can usually be ignored in preliminary analyses.) As shown at right, satellites orbiting an oblate body are attracted not only to its center but also towards its equator. This force component imposes a torque on all orbits that cross the equator at an angle, and causes the direction of the orbital angular momentum vector to regress as shown.

$\dot{\Omega}$ is largest when i is small, but the plane change associated with a given $\Delta\Omega$ varies with $\sin i$. Hence the actual plane change rate varies with $\sin i \cos i$, or $\sin 2i$, and is highest near 45° . For near-coplanar rendezvous in LEO, the required out-of-plane ΔV changes by $78 \sin 2i$ m/s for each phasing "lap". This is independent of the altitude difference (to first order), since phasing & differential nodal regression rates both scale with Δa . Hence even at best a rendezvous may require an out-of-plane ΔV of 39 m/s. At other times, out-of-plane ΔV s of $2 \sin i \sin(\Delta\Omega/2) V_{\text{circ}}$ (=up to $2 V_{\text{circ}}$!) are needed.

NOTES

The linkage between phasing and nodal regression rates is beneficial in some cases: if an object is boosted slightly and then allowed to decay until it passes below the boosting object, the total $\Delta\Omega$ is nearly identical for both. Hence recapture need not involve any significant plane change.

Apsidal recession generally has a much less dominant effect on operations, since apsidal adjustments (particularly of low- e orbits) involve much lower ΔV s than nodal adjustments. However, tether payload boosts may often be done from elliptical STS orbits, and perigee drift may be an issue. For example, OMS deboost requirements from an elliptical STS orbit are tonnes lower (and payload capability much higher) if perigee is near the landing site latitude at the end of the mission. Perigee motion relative to day/night variations is also important for detailed drag calculations, and for electrodynamic day-night energy storage (where it smears out and limits the eccentricity-pumping effect of a sustained day-night motor-generator cycle).

Just as torques occur when the central body is non-spherical, there are also torques when the satellite is non-spherical. These affect the satellite's spin axis and cause it to precess around the orbital plane at a rate that depends on the satellite's mass distribution and spin rate.

In high orbits, central-body perturbations become less important and 3rd-body effects more important. In GEO, the main perturbations (~ 47 m/s/yr) are caused by the moon and sun. The figure at right shows how to estimate these effects, using the 3rd body orbital plane as the reference plane.

REFERENCES

1. A.E. Roy, Orbital Motion, Adam Hilger Ltd., Bristol, 1978.
2. Bate, Mueller, & White, Fundamentals of Astrodynamics, Dover Pub., 1971.

Orbital Perturbations

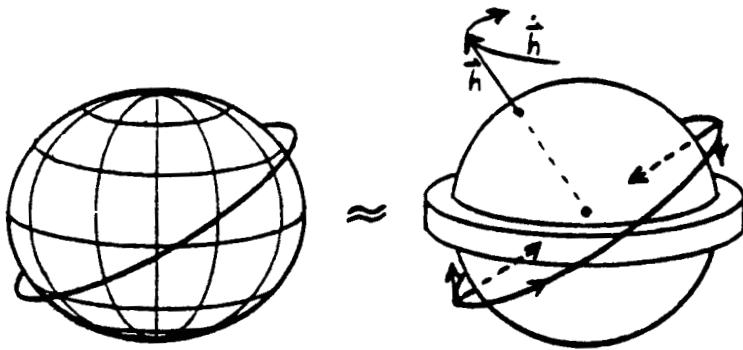

OBLATENESS CAUSES LARGE SECULAR CHANGES IN $\dot{\Omega}$ & $\dot{\omega}$:

$\dot{\Omega}$: up to 1 rad/week in LEO

$\dot{\omega}$: up to 2 rad/week in LEO

Nodal Regression in LEO:

$$\dot{\Omega} = \frac{-63.6 \cos i \text{ rad/yr}}{(a/r_e)^{3.5} (1-e^2)^2}$$

$(r_e = 6378 \text{ km})$

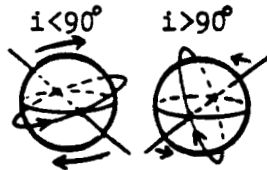

For sun-synchronous orbits: $(i = 100^\circ \pm 4^\circ)$

$$\cos i \approx -.0988(a/r_e)^{3.5}(1-e^2)^2$$

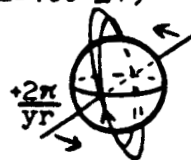

For coplanar low- ΔV rendezvous between 2 objects ($e_1 = e_2 \approx 0$, $i_1 = i_2$), nodal coincidence intervals are:

$$\Delta t_{nc} = \frac{180 (\bar{a}/r_e)^{4.5}}{\Delta a |\cos i|} \text{ km} \cdot \text{yrs}$$

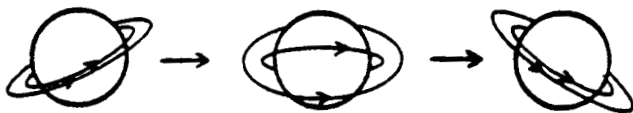

Apsidal recession in LEO:

$$\dot{\omega} = \frac{63.6(2 - 2.5 \sin^2 i)}{(a/r_e)^{3.5} (1-e^2)^2} \text{ rad/yr}$$

$i < 63.4^\circ$ $i = 63.4^\circ$ $i > 63.4^\circ$



Motion of the longitude of perigee with respect to the sun's direction ("noon") is:

$$\dot{\omega}_s = \dot{\omega} + \dot{\Omega} - 2\pi/\text{yr}$$

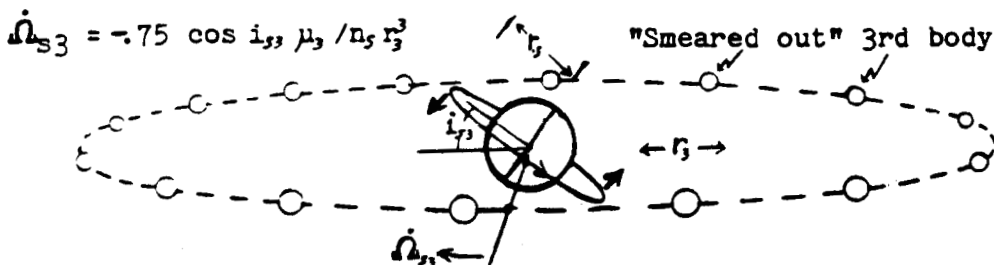

Third-Body Perturbations (non-resonant orbits)

KEY POINTS

Tether drag affects tether shape & orbital life; at. oxygen degrades tethers. Out-of-plane drag component can induce out-of-plane tether libration. The main value of payload boosting by tether is the increased orbital life. Unboosted orbital life of space facilities is affected by tether operations.

The figure at right shows the orbiter trolling a satellite in the atmosphere, as is planned for the 2nd TSS mission in the late 1980s. The tether drag greatly exceeds that on the end-masses and should be estimated accurately. The drag includes a small out-of-plane component that can cause ϕ -libration.

Tether drag is experienced over a range of altitudes, over which most of the terms in the drag equation vary: the air density ρ , the airspeed V_{rel} , and the tether width & angle of attack. In free-molecular flow, C_L is small, and C_D (if based on A_{\perp}) is nearly constant at 2.2. (C_D rises near grazing incidence, but then A_{\perp} is low.)

Only ρ varies rapidly, but it varies in a way which lends itself to simple approximations. Empirical formulae have been developed by the author and are shown at right. They give values that are usually within 25% of ref. 1, which is still regarded as representative for air density as a function of altitude & exosphere temperature. These estimates hold only for $\rho > 1E-14$, beyond which helium & hydrogen dominate & the density scale height H increases rapidly.

NOTES

Note that over much of LEO, atomic oxygen is the dominant species. Hyperthermal impact of atomic oxygen on exposed surfaces can cause rapid degradation, and is a problem in low-altitude applications of organic-polymer tethers.

The space age began in 1957 at a 200-yr high in sunspot count. A new estimate of mean solar cycle temperatures (at right, from ref. 2), is much lower than earlier estimates. Mission planning requires both high & mean estimates for proper analysis. Ref. 2 & papers in the same volume discuss models now in use.

If the tether length L is $\ll H$, the total tethered system drag can be estimated from the total A_{\perp} & the midpoint V & ρ . If $L \gg H$, the top end can be neglected, the bottom calculated normally, and the tether drag estimated from $L \cdot \rho_{bottom} \cdot \text{tether diameter} \cdot H \cdot V_{rel}^2$, with H & V_{rel} evaluated one H above the bottom of the tether. For L between these cases, the drag is bounded by these cases.

As shown at right, the orbital life of more compact objects (such as might be boosted or deboosted by tether) can be estimated analytically if T_{ex} is known. For circular orbits with the same r , V_{rel} & ρ both vary with i , but these variations tend to compensate & can both be ignored in first-cut calculations.

The conversion of elliptical to "equal-life" circular orbits is an empirical fit to an unpublished parametric study done by the author. It applies when apsidal motions relative to the equator and relative to the diurnal bulge are large over the orbital life; this usually holds in both low & high- i orbits. For a detailed study of atmospheric drag effects, ref. 3 is still useful.

REFERENCES

1. U.S. Standard Atmosphere Supplements, 1966. ESSA/NASA/USAF, 1966.
2. K.S.W. Champion, "Properties of the Mesosphere and Thermosphere and Comparison with CIRA 72", in The Terrestrial Upper Atmosphere, Champion and Roemer, ed.; Vol 3, #1 of Advances in Space Research, Pergamon, 1983.
3. D.G. King-Hele, Theory of Satellite Orbits in an Atmosphere, Butterworths, London, 1964.

Aerodynamic Drag

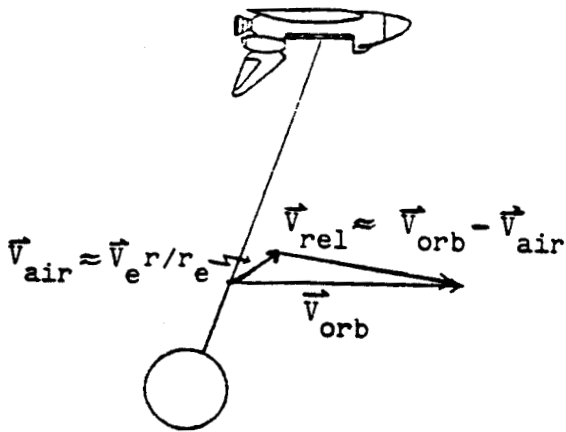

$$F_{drag} = .5 \rho C_D v_{rel}^2 \text{ Width } \delta r$$

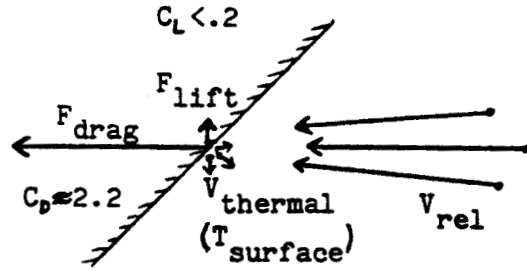

Lift & Drag in Free-Molecular Flow

$$(\bar{\lambda} \gg D_{tether}; \bar{\lambda} \approx \frac{10^{-7} \text{ kg/m}^2}{\rho})$$

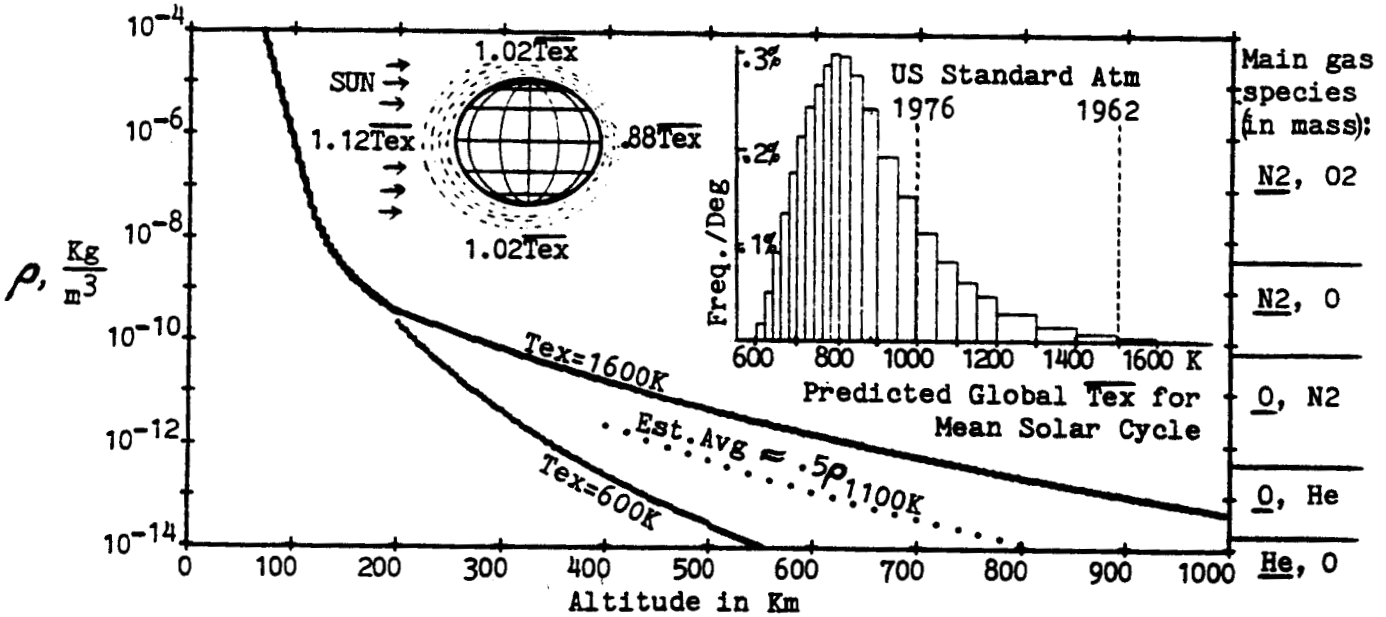
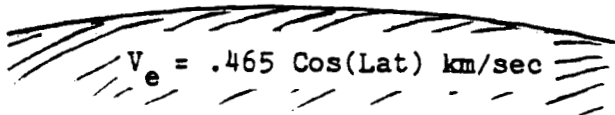

Air Density as Function of Altitude & Exosphere Temperature

70 < Alt < 118: $\rho \approx 11 \exp(-\text{Alt}/6)$	$-\rho/\dot{\rho} = H = 6 \text{ (km)}$
118 < Alt < 200: $\rho \approx (\text{Alt}-95)^{-3}/2600$	$H = (\text{Alt}-95)/3$
200 < Alt < 1E-14 &: $\rho \approx \frac{1.47E-16 \text{ Tex}(3000-\text{Tex})}{(1+2.9(\text{Alt}-200)/\text{Tex})^{10}}$	$H = .1(\text{Alt}-200) + \text{Tex}/29$

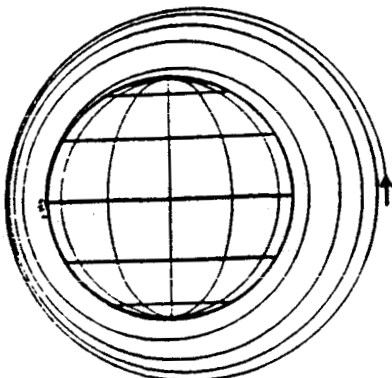

Circular Orbit Life $\approx \frac{.15 \text{ m}^2 \text{ yr}}{\text{kg}} \frac{M}{C_D A} \frac{(1 + 2.9(r-6578)/\text{Tex})^{11}}{3000 - \text{Tex}}$
 (-14 < Log rho < -10)

Equal-Life Circ. Alt. $\approx \text{Perigee} + \frac{\text{Apo} - \text{Per}}{2 + .154(\text{Apo}-\text{Per})/H_{\text{Per}}}$

KEY POINTS

Aerothermal heating of tethers is severe at low altitudes (<120 km). Tether temperature affects strength, toughness, & electrical conductivity. Extreme thermal cycling may degrade pultruded composite tethers. "View factors" are also used in refined micrometeoroid risk calculations.

Preliminary heat transfer calculations in space are often far simpler than typical heat transfer calculations on the ground, since the complications introduced by convection are absent. However the absence of the "clamping" effect of large convective couplings to air or liquids allows very high or low temperatures to be reached, and makes thermal design important.

At altitudes below about 140 km in LEO, aerodynamic heating is the dominant heat input on surfaces facing the ram direction. The heating scales with ρ as long as the mean free path λ is much larger than the object's radius. It is about equal to the energy dissipated in stopping incident air molecules. In denser air, shock & boundary layers develop. They shield the surface from the incident flow and make \dot{Q} rise slower as ρ increases further. (See ref 1.)

Because tethers are narrow, they can be in free molecular flow even at 100 km, and may experience more severe heating than the (larger) lower end masses do. Under intense heating high temperature gradients may occur across non-metallic tethers. These gradients may cause either overstress or stress relief on the hot side, depending on the sign of the axial thermal expansion coefficient.

NOTES

At higher altitudes the environment is much more benign, but bare metal (low-emittance) tethers can still reach high temperatures when resistively heated or in the sun, since they radiate heat poorly. Silica, alumina, or organic coatings $>1 \mu\text{m}$ thick can increase emittance and hence reduce temperatures. The temperature of electrodynamic tethers is important since their resistance losses (which may be the major system losses) scale roughly with T_{abs} .

For a good discussion of solar, albedo, and longwave radiation, see ref. 2. The solid geometry which determines the gains from these sources is simple but subtle, and should be done carefully. Averaged around a tether, earth view-factors change only slowly with altitude & attitude, and are near .3 in LEO.

Surface property changes can be an issue in long-term applications, due to the effects of atomic oxygen, UV & high-energy radiation, vacuum, deposition of condensible volatiles from nearby surfaces, thermal cycling, etc. Hyper-thermal atomic oxygen has received attention only recently, and is now being studied in film, fiber, and coating degradation experiments on the STS & LDEF.

Continued thermal cycling over a wide range (such as shown at bottom right) may degrade composite tethers by introducing a maze of micro-cracks. Also, temperature can affect the strength, stiffness, shape memory, and toughness of tether materials, and hence may affect tether operations and reliability.

REFERENCES

-
1. R.N. Cox & L.F. Crabtree, Elements of Hypersonic Aerodynamics, The English Universities Press Ltd, London, 1965. See esp. Ch 9, "Low Density Effects"
 2. F.S. Johnson, ed., Satellite Environment Handbook, Second Edition, Stanford University Press, 1965. See chapters on solar & earth thermal radiation.
 3. H.C. Hottel, "Radiant Heat Transmission," Chapter 4 of W.H. McAdams, HEAT TRANSMISSION, 3rd edition, McGraw-Hill, New York, 1954, pp. 55-125.

Thermal Balance

ORIGINAL PAGE IS
OF POOR QUALITY

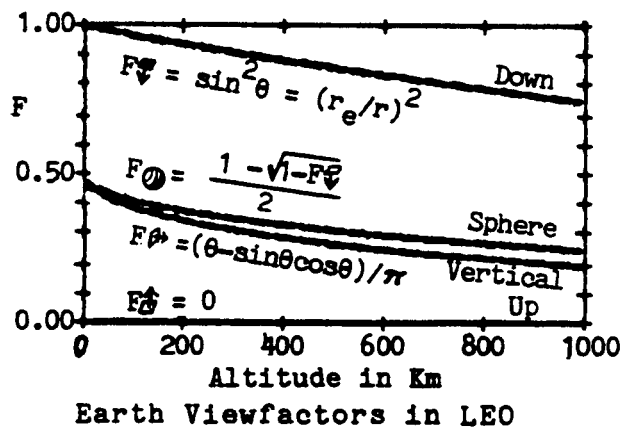
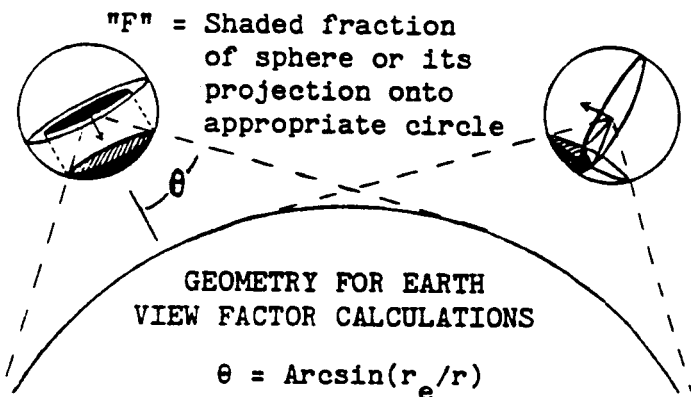
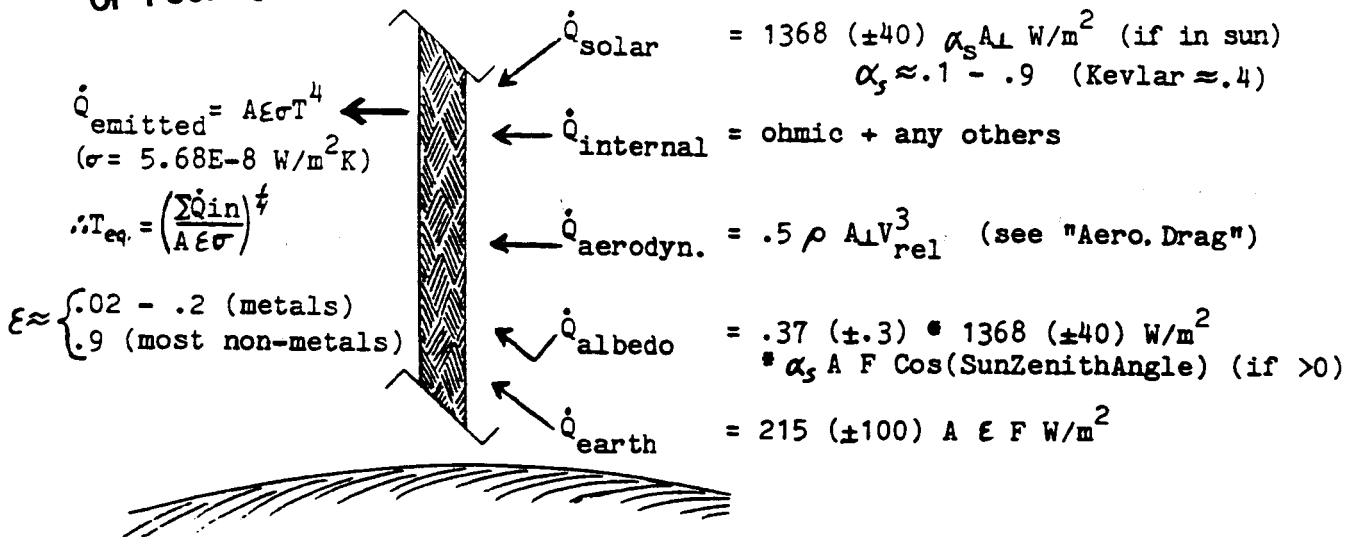

$F_{\parallel} = F_{\downarrow}$
 $F_{\text{tether}} \approx (F_{\downarrow} + F_{\uparrow} + 2F_{\text{Sphere}}) / 4$
 $F_{\parallel} < F_{\text{tether}} < F_{\text{Sphere}}$

Earth Viewfactors for Tethers

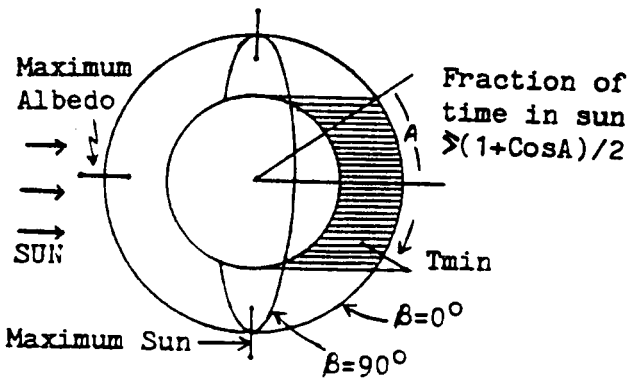

Inclination	β Range
0°	0-23.5°
28.5°	0-51°
$> 66.5^\circ$	0-90°

(β = Sun out-of-plane angle)

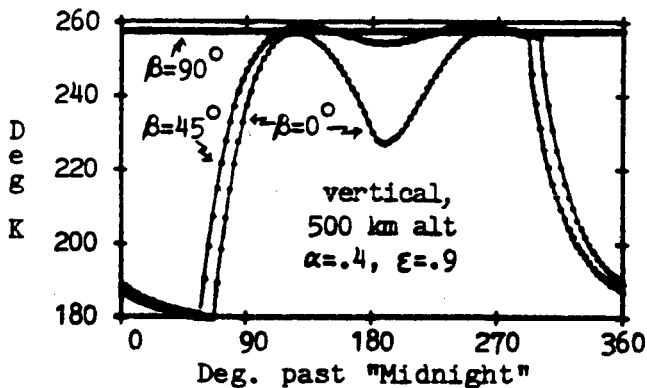

KEY POINTS Micrometeoroids can sever thin tethers & damage tether protection/insulation.
Orbiting debris can sever tethers of any diameter.

At the start of the space age, estimates of meteoroid fluxes varied widely. Earth was thought to have a dust cloud around it, due to misinterpretation of data such as microphone noise caused by thermal cycling in spacecraft. By the late 1960s most meteoroids near earth were recognized to be in heliocentric rather than geocentric orbit. The time-averaged flux is mostly sporadic, but meteor showers can be dominant during their occurrence.

There is a small difference between LEO and deep-space fluxes, due to the focusing effect of the earth's gravity (which increases the velocity & flux), and the partial shielding provided by the earth & "sensible" atmosphere. For a typical meteoroid velocity of 20 km/sec, these effects combine to make the risk vary as shown at right in LEO, GEO, and beyond. The picture of a metal plate after hypervelocity impact is adapted from ref. 3.

NOTES

The estimated frequency of sporadic meteoroids over the range of interest for most tether applications is shown by the straight line plot at right, which is adapted from ref. 4 & based on ref. 1. (Ref 1 is still recommended for design purposes.) For masses $<1E-6$ gm ($<.15$ mm diam. at an assumed density of .5), the frequency is lower than an extension of that line, since several effects clear very small objects from heliocentric orbits in geologically short times.

Over an increasing range of altitudes and particle sizes in LEO, the main impact hazard is due not to natural meteoroids but rather to man-made objects. The plots at right, adapted from refs 4 & 5, show the risks presented by the 5,000 or so objects tracked by NORAD radars (see ref. 6). A steep "tail" in the 1995 distribution is predicted since it is likely that several debris-generating impacts will have occurred in LEO before 1995. Such impacts are expected to involve a 4-40 cm object striking one of the few hundred largest objects and generating millions of small debris fragments.

Recent optical detection studies which have a size threshold of about 1 cm indicate a population of about 40,000 objects in LEO. This makes it likely that debris-generating collisions have already occurred. Studies of residue in small surface pits on the shuttle and other objects recovered from LEO indicate that they appear to be due to titanium, aluminum, and paint fragments (perhaps flaked off satellites by micrometeoroid hits). Recovery of the Long Duration Exposure Facility (LDEF) later this year should improve this database greatly, and will provide data for LEO exposure area-time products comparable to those in potential long-duration tether applications.

REFERENCES

-
1. Meteoroid Environment Model—1969 [Near Earth to Lunar Surface], NASA SP-8013, March 1969.
 2. Meteoroid Environment Model—1970 [Interplanetary and Planetary], NASA SP-8038, October 1970.
 3. Meteoroid Damage Assessment, NASA SP-8042, May 1970. Shows impact effects.
 4. D.J. Kessler, "Sources of Orbital Debris and the Projected Environment for Future Spacecraft", in J. of Spacecraft & Rockets, Vol 18 #4, Jul-Aug 1981.
 5. D.J. Kessler, Orbital Debris Environment for Space Station, JSC-20001, 1984.
 6. CLASSY Satellite Catalog Compilations. Issued monthly by NORAD/J5YS, Peterson Air Force Base, CO 80914.

Micrometeoroids & Debris

ORIGINAL PAGE IS
OF POOR QUALITY

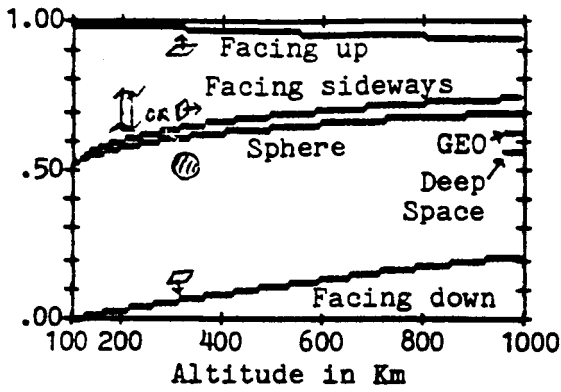

Relative μm Risks in LEO
 $[\text{RelRisk} \approx (1 - F_{\text{earth}})(.57 + .43r_e/r)]$

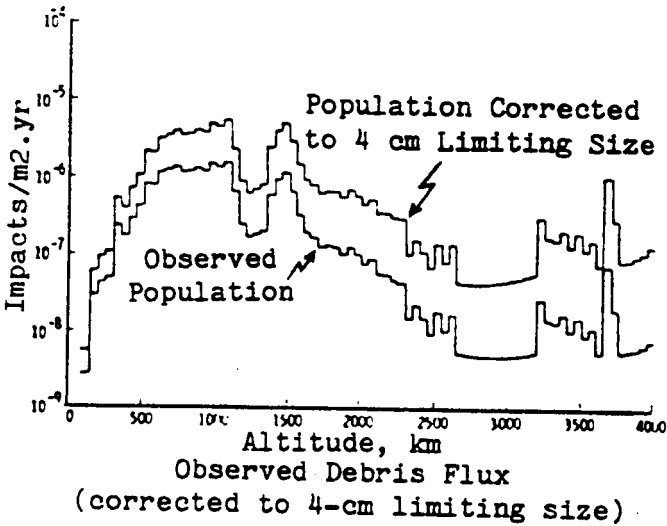

Observed Debris Flux (corrected to 4-cm limiting size)

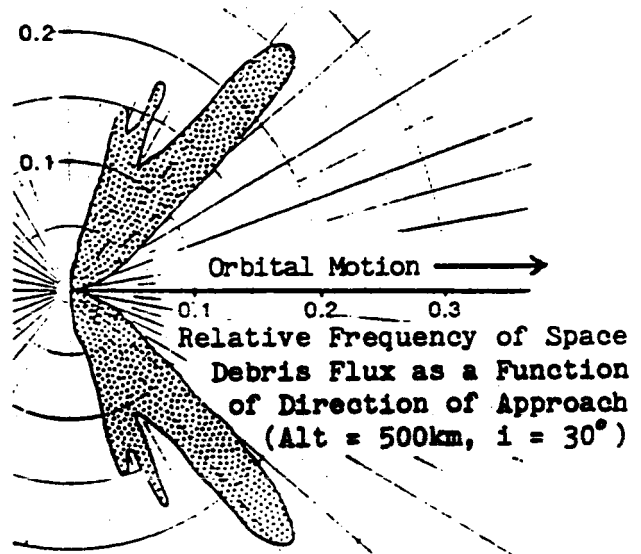
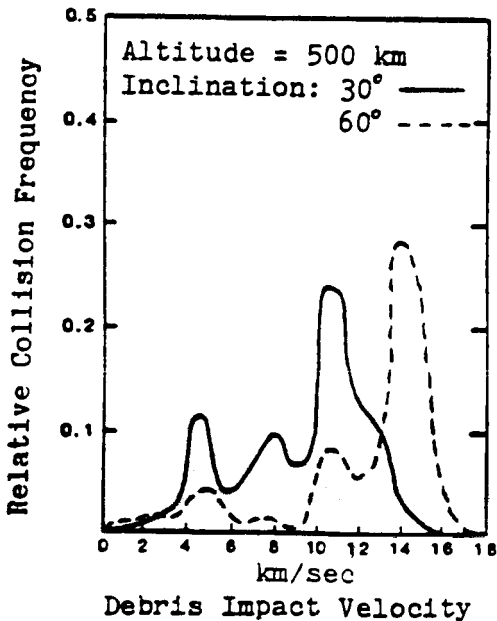
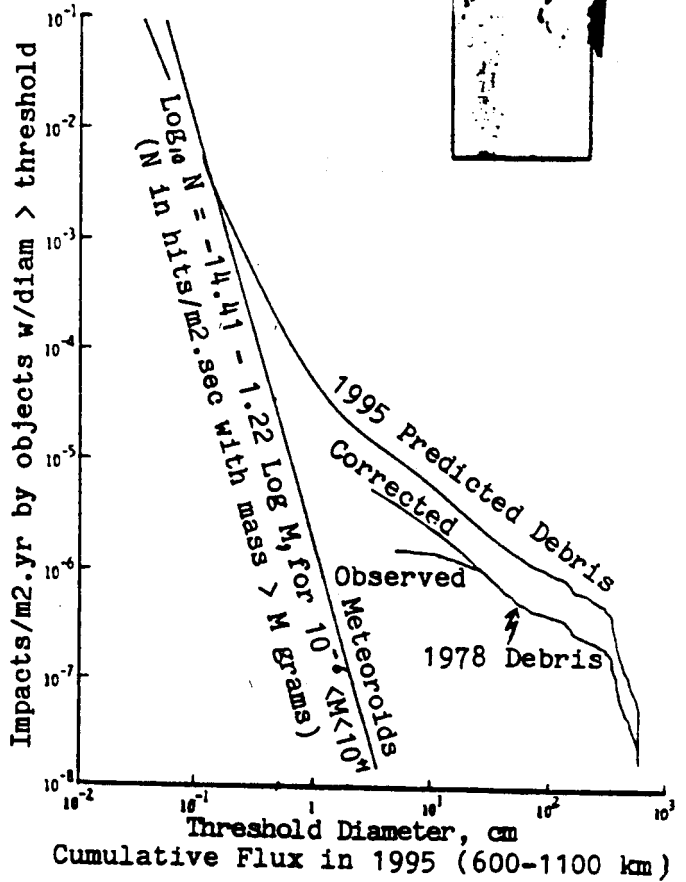

KEY POINTS "Microgee" environments are possible only in small regions (~5 m) of a LEO facility. Milligee-level gravity is easy to get & adequate for propellant settling, etc.

The figure at right shows the reason for gravity-gradient effects. The long tank-like object is kept aligned with the local vertical, so that the same end always faces the earth as it orbits around it. If one climbs from the bottom to the top, the force of gravity gradually decreases and the centrifugal force due to orbital motion increases. Those forces cancel out only at one altitude, which is (nearly but not exactly) the altitude of the vehicle's center of mass.

At other locations an object will experience a net force vertically away from the center of mass (or a net acceleration, if the object is allowed to fall). This net force is referred to as the "gravity-gradient force." (But note that 1/3 of the net force is actually due to a centrifugal force gradient!) Exact and approximate formulas for finding the force on an object are given at right.

NOTE The force occurs whether or not a tether is present, and whether or not it is desirable. Very-low-acceleration environments, which are needed for some types of materials processing and perhaps for assembling massive structures, are only available over a very limited vertical extent, as shown at right. Putting a vehicle into a slow retrograde spin can increase the "height" of this low-gee region, but that then limits the low-gee region's other in-plane dimension.

Since gravity gradients in low orbits around various bodies vary with μ/r^3 , the gradients are independent of the size of the body, and linearly dependent on its density. Hence the gradients are highest (.3-.4 milligee/km) around the inner planets and Earth's moon, and 60-80% lower around the outer planets. In higher orbits, the effect decreases rapidly (to 1.6 microgee/km in GEO).

The relative importance of surface tension and gravity determines how liquids behave in a tank, and is quantified with the Bond number, $Bo = \rho a r^2 / \alpha$. If $Bo > 10$, liquids will settle, but higher values ($Bo = 50$) are proposed as a conservative design criterion.² On the other hand, combining a small gravity gradient effect ($Bo < 10$) with minimal surface-tension fluid-management hardware may be more practical than either option by itself. Locating a propellant depot at the end of a power-tower structure might provide an adequate gravity-gradient contribution. If higher gravity is desired, but without deploying the depot, another option is to deploy an "anchor" mass on a tether, as shown at right.

Many nominally "zero-gee" operations such as electrophoresis may actually be compatible with useful levels of gravity (i.e., useful for propellant settling, simplifying hygiene activities, keeping objects in place at work stations, etc). This needs to be studied in detail to see what activities are truly compatible.

- REFERENCES
1. D. Arnold, "General Equations of Motion," Appendix A of Investigation of Electrodynamic Stabilization and Control of Long Orbiting Tethers, Interim Report for Sept 1979 - Feb 1981, Smithsonian Astrophys. Observ., March 1981.
 2. K.R. Kroll, "Tethered Propellant Resupply Technique for Space Stations," IAF-84-442, presented at the 35th IAF Congress, Lausanne Switzerland, 1984.

Gravity Gradient Effects

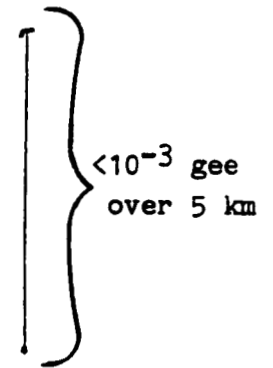
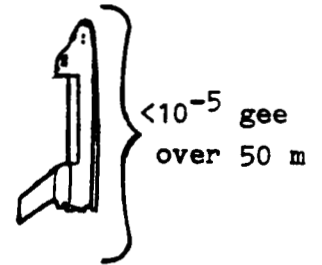
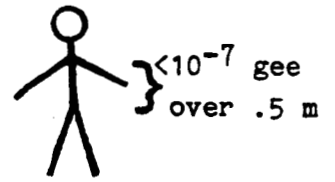
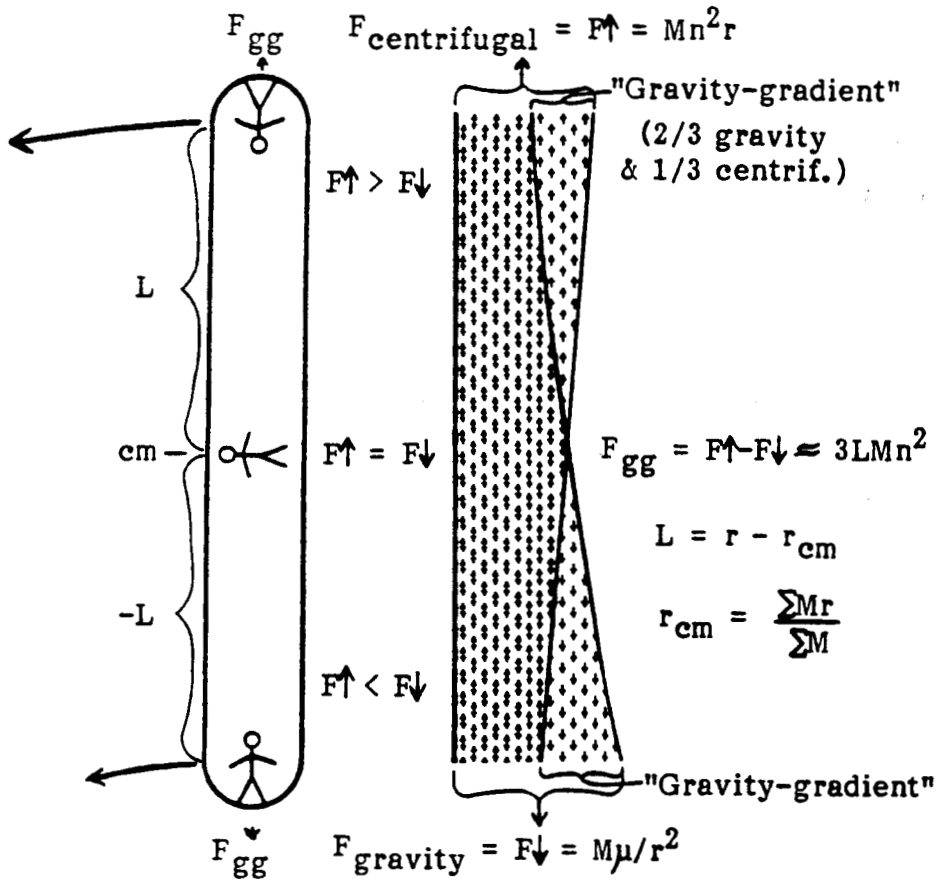

Origin of "Gravity-Gradient" Forces

Magnitude of Gravity Gradient Effects in LEO

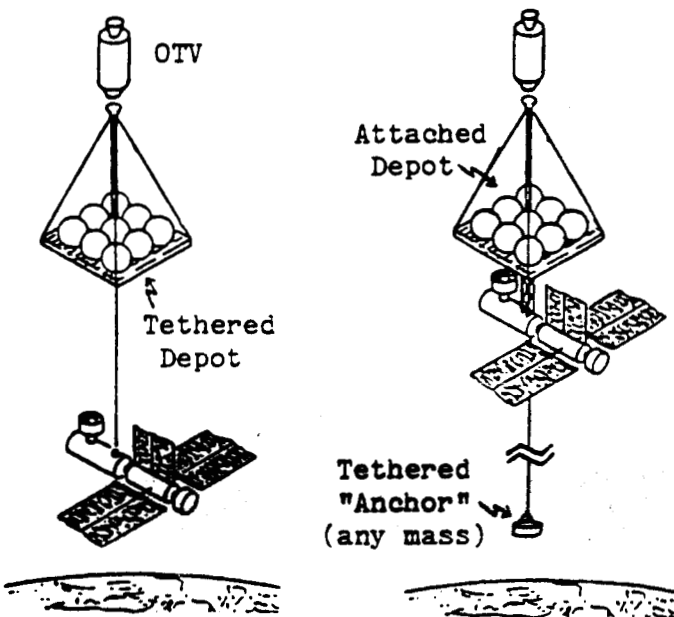

Crystal Growth	→ ?	? ←	Calcium Retention
Latex Reactors	→ ?	? ←	Walking
Electrophoresis	→ ?	? ←	"Desktop" work
LSS Assembly	→ ?	? ←	Eating, Hygiene
	→ ?	? ←	Fluid Settling
Microgravity			Full Gravity

10^{-3} G

Potential Overlap of Regions for Low-Gee & Gee-Dependent Operations

Two Propellant-Settling Options

KEY POINTS Libration periods are independent of length, but increase at large amplitude. Out-of-plane libration can be driven by weak forces that have a $2n$ component. Tethers can go slack if $\theta_{\max} > 65^\circ$ or $\phi_{\max} > 60^\circ$.

The two figures at right show the forces on a dumbbell in circular orbit which has been displaced from the vertical, and show the net torque on the dumbbell, returning it towards the vertical. The main difference between the two cases is that the centrifugal force vectors are radial in the in-plane case, and parallel in the out-of-plane case. This causes the net force in the out-of-plane case to have a smaller axial component and a larger restoring component, and is why ϕ -libration has a higher frequency than θ -libration.

Four aspects of this libration behavior deserve notice. First, the restoring forces grow with the tether length, so libration frequencies are independent of the tether length. Thus tether systems tend to librate "solidly", like a dumbbell, rather than with the tether trying to swing faster than the end-masses as can be seen in the chain of a child's swing. (This does not hold for very long tethers, since the gravity gradient itself varies.) For low orbits around any of the inner planets or the moon, libration periods are roughly an hour.

NOTES

Second, tethered masses would be in free-fall except for the tether, so the sensed acceleration is always along the tether (as shown by the stick-figures). Third, the axial force can become negative, for $\phi > 60^\circ$ or near the ends of retrograde in-plane librations $> 65.9^\circ$. This may cause problems unless the tether is released, or retrieved at an adequate rate to prevent slackness.

And fourth, although θ -libration is not close to resonance with any significant driving force, ϕ -libration is in resonance with several, such as out-of-plane components of aerodynamic forces (in non-equatorial orbits that see different air density in northward and southward passes) or electrodynamic forces (if tether currents varying at the orbital frequency are used). The frequency droop at large amplitudes (shown at right) sets a finite limit to the effects of weak but persistent forces, but this limit is quite high in most cases.

The equations given at right are for an essentially one-dimensional structure, with one principal moment of inertia far smaller than the other two: $A \ll B < C$. If A is comparable to B & C , then the θ -restoring force shrinks with $(B-A)/C$, and the θ -libration frequency by $\text{Sqrt}((B-A)/C)$. Another limitation is that a coupling between ϕ & θ behavior (see ref. 1) has been left out. This coupling is caused by the variation of end-mass altitudes twice in each ϕ -libration. This induces Coriolis accelerations that affect θ . This coupling is often unimportant, since $4n$ is far from resonance with $L.73n$.

Libration is referenced to the local vertical, and when a dumbbell is in an eccentric orbit, variations in the orbital rate cause librations which in turn exert periodic torques on an initially uniformly-rotating object. In highly eccentric orbits this can soon induce tumbling.²

REFERENCES

1. D. Arnold, "General Equations of Motion," Appendix A of Investigation of Electrodynamic Stabilization and Control of Long Orbiting Tethers, Interim Report for Sept 1979—Feb 1981, Smithsonian Astrophys. Observ., March 1981.
2. P.A. Swan, "Dynamics & Control of Tethers in Elliptical Orbits," IAF-84-361, presented at the 35th IAF Congress, Lausanne, Switzerland, October 1984.

Dumbbell Libration in Circular Orbit

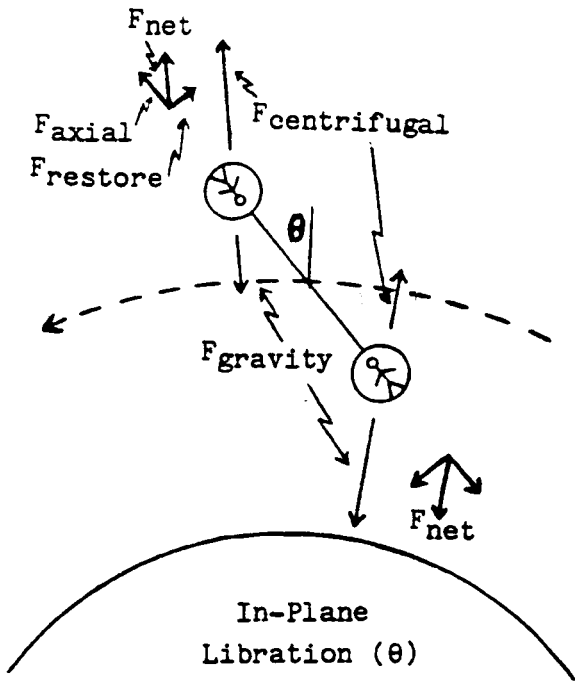

$$\ddot{\theta} \approx -3n^2 \sin\theta \cos\theta = -1.5n^2 \sin(2\theta)$$

$$\dot{\theta} \approx \pm \sqrt{3} n \sqrt{\sin^2 \theta_{\max} - \sin^2 \theta}$$

$$(\dot{\theta} \approx \pm \sqrt{3} n \sin \theta_{\max} \text{ when } \theta=0)$$

$$n_{\theta} \approx n \sqrt{3 \cos \theta_{\max}}$$

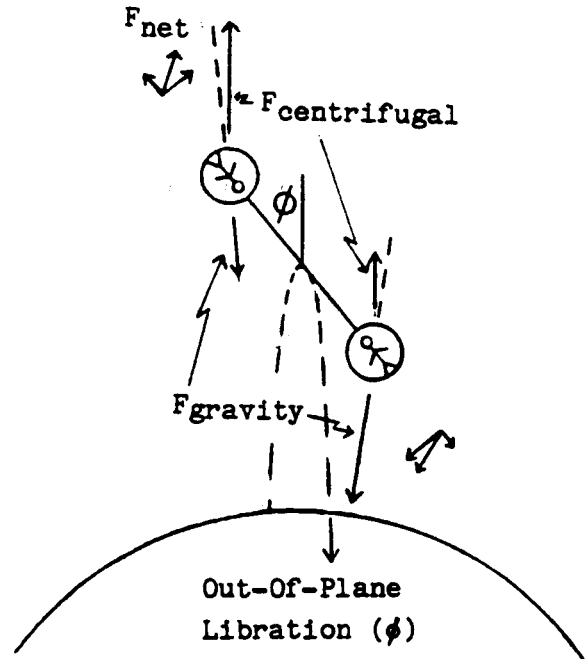

$$\ddot{\phi} \approx -4n^2 \sin\phi \cos\phi = -2n^2 \sin(2\phi)$$

$$\dot{\phi} \approx \pm 2n \sqrt{\sin^2 \phi_{\max} - \sin^2 \phi}$$

$$(\dot{\phi} \approx \pm 2n \sin \phi_{\max} \text{ when } \phi=0)$$

$$n_{\phi} \approx 2n \sqrt{\cos \phi_{\max}}$$

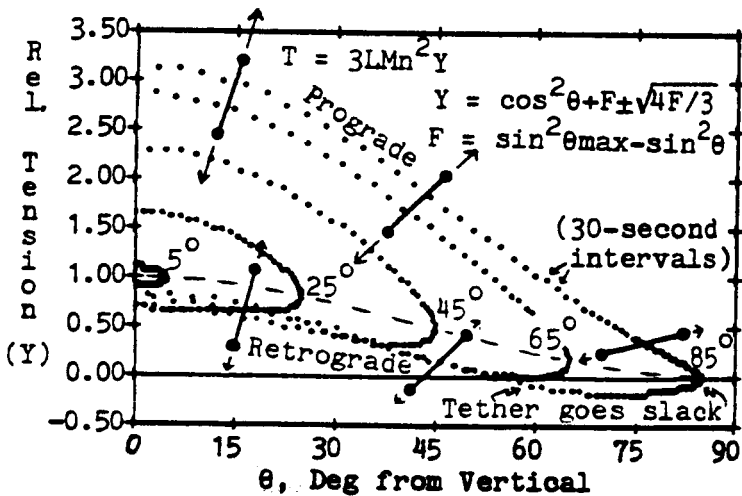

Tension Variations in Librating Dumbbells
(compared to tension in hanging dumbbells)

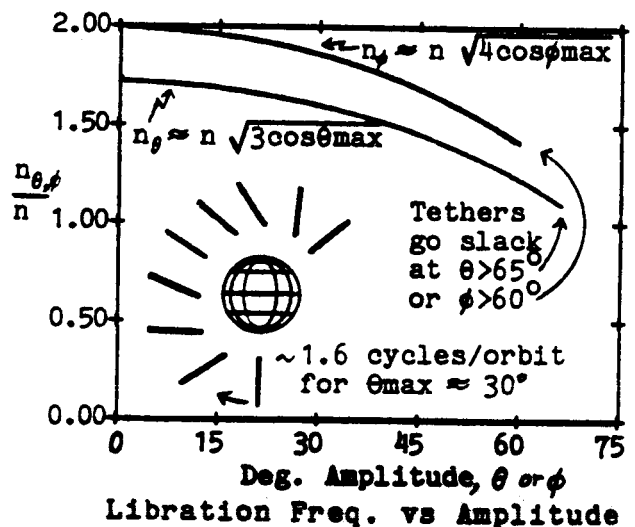

KEY POINTS Open-loop control is adequate for deployment; full retrieval requires feedback. Tension laws can control θ & ϕ -libration plus tether oscillations. Many other options exist for libration, oscillation, & final retrieval control.

The table at right shows half a dozen distinct ways in which one or more aspects of tethered system behavior can be controlled. In general, anything which can affect system behavior (and possibly cause control problems) can be part of the solution, if it itself can be controlled without introducing other problems.

Thus, for example, stiff tethers have sometimes been considered undesirable, because the stiffness competes with the weak gravity-gradient forces near the end of retrieval. However, if the final section of tether is stiff AND nearly straight when stress-free (rather than pig-tail shaped), then "springy beam" control laws using a steerable boom tip might supplement or replace other laws near the end of retrieval. A movable boom has much the same effect as a stiff tether & steerable boom tip, since it allows the force vector to be adjusted.

NOTES The basic concepts behind tension-control laws are shown at right. Libration damping is done by paying out tether when the tension is greater than usual and retrieving it at other times. This absorbs energy from the libration. As shown on the previous page, in-plane libration causes large variations in tension (due to the Coriolis effect), so "yo-yo" maneuvers can damp in-plane librations quickly. Such yo-yo maneuvers can be superimposed on deployment and retrieval, to allow large length changes (>4:1) plus large in-plane libration damping (or initiation) in less than one orbit, as proposed by Swet.¹

Retrieval laws developed for the TSS require more time than Ref. 1, because they also include damping of out-of-plane libration built up during stationkeeping. Rupp developed the first TSS control law in 1975;² much of the work since then is reviewed in (3). Recent TSS control concepts combine tension and thrust control laws, with pure tension control serving as a backup in case of thruster failure.⁴ Axial thrusters raise tether tension when the tether is short, while others control yaw & damp out-of-plane libration to allow faster retrieval.

A novel concept which in essence eliminates the final low-tension phase of retrieval is to have the end mass climb up the tether.⁵ Since the tether itself remains deployed, its contribution to gravity-gradient forces and stabilization remains. The practicality of this will vary with the application.

- REFERENCES**
1. C.J. Swet, "Method for Deploying and Stabilizing Orbiting Structures", U.S. Patent #3,532,298, October 6, 1970.
 2. C.C. Rupp, A Tether Tension Control Law for Tether Subsatellites Deployed Along Local Vertical, NASA TM X-64963, MSFC, September 1, 1975.
 3. V.J. Modi, Geng Chang-Fu, A.K. Misra, and Da Ming Xu, "On the Control of the Space Shuttle Based Tethered Systems," Acta Astronautica, Vol. 9, No. 6-7, pp. 437-443, 1982.
 4. A. K. Banerjee and T.R. Kane, "Tethered Satellite Retrieval with Thruster Augmented Control," AIAA 82-1-21, presented at the AIAA/AAS Astrodynamics Conference, San Diego, Calif., 1982.
 5. T.R. Kane, "A New Method for the Retrieval of the Shuttle-Based Tethered Satellite," J. of the Astronaut. Sci., Vol 32, No. 3, July-Sept. 1984.

Tether Control Strategies

EFFECTIVENESS OF VARIOUS CONTROL CONCEPTS

APPLICATION CONTROL OUTPUT	Libration		Tether Oscillations		Endmass Attitude Osc.	
	In-plane	Out-of-plane	Longitudinal	Transverse	Pitch & Roll	Yaw
Tension	Strong	Weak (Note: tension control is weak when tether is short)	Strong	Strong	Strong	None
El. Thrust	Only if $M1 \neq M2$		None	Only odd harmonics	None	None
Thruster	Strong, but costly if prolonged			None	Strong, but costly if prolonged	
Movable mass	Good w/short tether		Possible but awkward		None	None
Stiff tether, Movable boom	Strong if tether is very short; weak otherwise					
Aerodynamic	High drag—use only if low altitude needed for other reasons.					

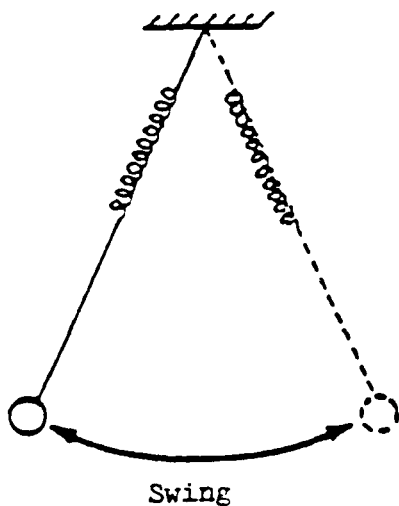

Deploying & retrieving tether at different tensions absorbs energy and damps libration.

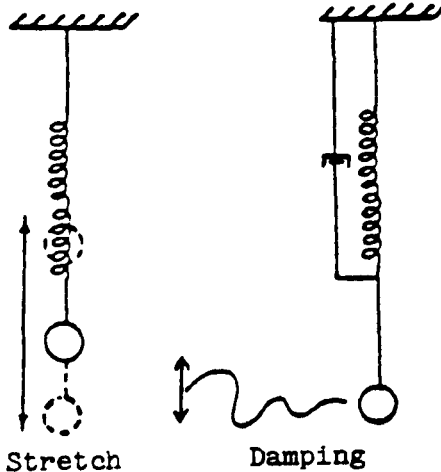

$$\text{Tension} = k_1(L - L_c) + k_2\dot{L}$$

(k_1 & k_2 are control gains;
 L & L_c are the actual and the commanded tether length.)

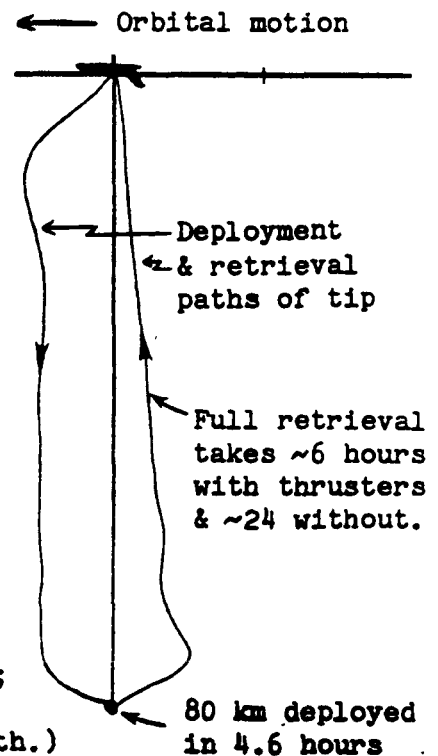

TENSION CONTROL FOR LIBRATION DAMPING... AND DEPLOYMENT/RETRIEVAL

KEY POINTS Tethers merely redistribute angular momentum; they do not create it. Changes in tether length, libration, and spin all redistribute momentum. Momentum transfer out-of-plane or in deep space is possible but awkward.

The two figures at right show two different tether deployment (and retrieval) techniques. In both cases, the initial deployment (which is not shown) is done with RCS burns or a long boom. In the case at left, the tether is paid out under tension slightly less than the equilibrium tension level for that tether length. The tether is slightly tilted away from the vertical during deployment, and librates slightly after deployment is complete.

In the other case, after the initial near-vertical separation (to about 2% of the full tether length), the two end masses are allowed to drift apart in near-free-fall, with very low but controlled tension on the tether. Just under one orbit later, the tether is almost all deployed and the range rate decreases to a minimum (due to orbital mechanics). RCS burns or tether braking are used to cushion the end of deployment and prevent end mass recoil. Then the tether system begins a large-amplitude prograde swing towards the vertical.

NOTES In both cases, the angular momentum transferred from one mass to the other is simply, as stated in the box, the integral over time of the radius times the horizontal component of tether tension. In one case, transfer occurs mainly during deployment; in the other, mainly during the libration after deployment. In each case, momentum transfer is greatest when the tether is vertical, since the horizontal component of tether tension changes sign then.

An intermediate strategy—deployment under moderate tension—has also been investigated.¹ However, this technique results in very high deployment velocities and large rotating masses. It also requires powerful brakes and a more massive tether than required with the other two techniques.

As discussed under Tether Control Strategies, changing a tether's length in resonance with variations in tether tension allows pumping or damping of libration or even spin. Due to Coriolis forces, in-plane libration and spin cause far larger tension variations than out-of-plane libration or spin, so in-plane behavior is far easier to adjust than out-of-plane behavior. Neglecting any parasitic losses in tether hysteresis & the reel motor, the net energy needed to induce a given libration or spin is simply the system's spin kinetic energy relative to the local vertical, when the system passes through the vertical.

Two momentum transfer techniques which appear applicable for in-plane, out-of-plane, or deep-space use are shown at right. The winching operation can use lighter tethers than other tethered-momentum-transfer techniques, but requires a very powerful deployer motor. The tangential ΔV simply prevents a collision.

The spin-up operation (proposed by Harris Mayer) is similar to the winching operation. It uses a larger tangential ΔV , a tether with straight and tapered sections, and a small motor. Retrieval speeds up the spin by a factor of L^{-2} . Surprisingly, the long tapered section of tether can be less than half as massive as the short straight section that remains deployed after spin-up.

REFERENCE 1. J. Tschirgi, "Tether-Deployed SSUS-A, report on NASA Contract NAS8-32842, McDonnell Douglas, April 1984.

Momentum Transfer

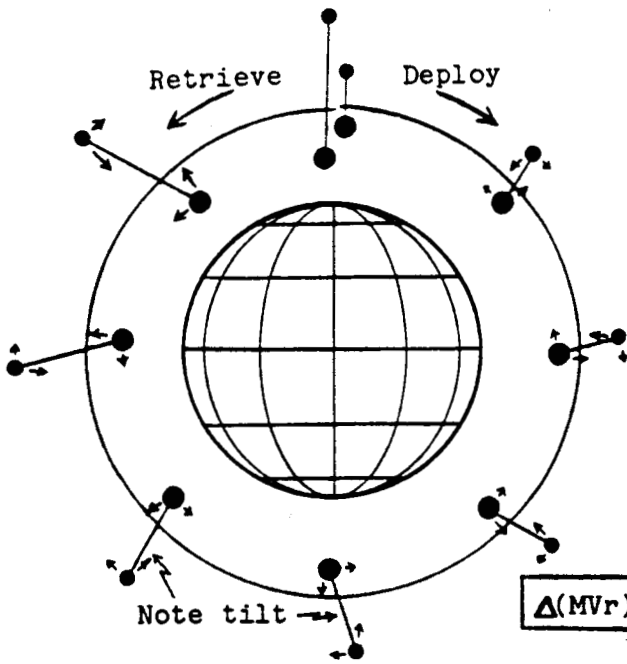

Momentum Transfer During Deployment & Retrieval

$$\Delta(MVr) = rT\sin\theta\delta t$$

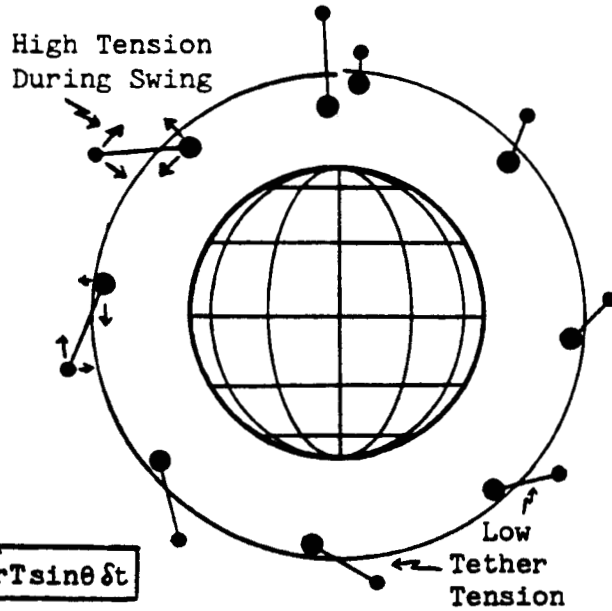

Momentum Transfer During Libration (after low-tension deployment)

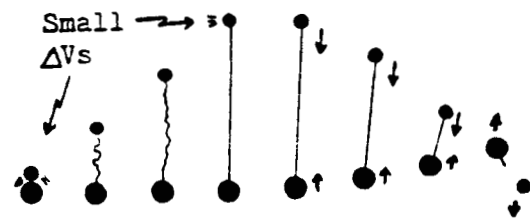
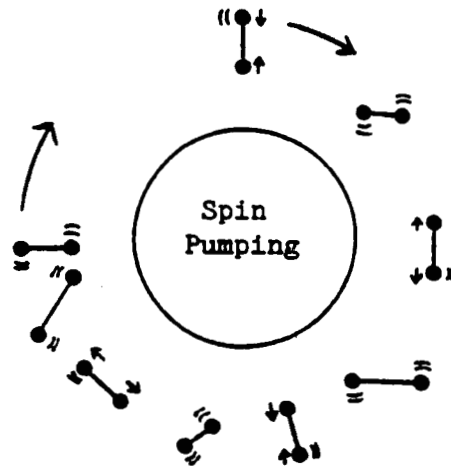
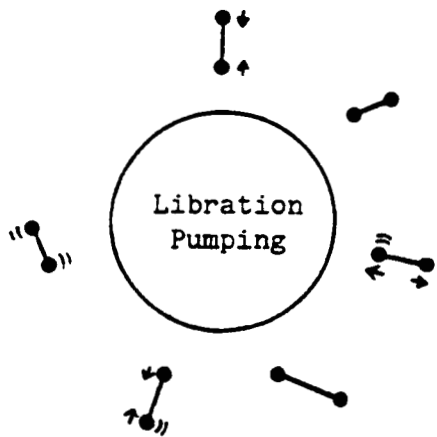

Deployment Followed by Winching (in orbit or in deep space)

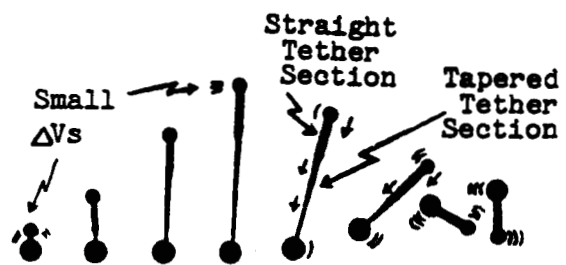

One Spin-Up Technique For Use in Deep Space

KEY POINTS

The achievable orbit change scales with the tether length (as long as $\Delta r \ll r$). Retrograde-libration releases are inefficient, but allow concentric orbits. Apogee & perigee boosts have different values in different applications. Tethered capture can be seen as a time-reversal of a tether release operation.

The figures to the right show the size of the orbit changes caused by various tether operations. When released from a vertical tether, the end masses are obviously one tether length apart in altitude. The altitude difference 1/2 orbit later, $\Delta r_{1/2}$, varies with the operation but is usually far larger. The linear relationship shown becomes inaccurate when Δr approaches r . Tethered plane changes are generally limited to a few degrees and are not covered here.

Tether release leaves the center-of-mass radius at each phase angle roughly unchanged: if the upper mass is heavier, then it will rise less than the lower mass falls, and vice-versa. Note that the libration amplitude, θ_{max} , is taken as positive during prograde libration & negative during retrograde libration. Hence retrograde libration results in $\Delta r < 7L$. In particular, the pre-release & post-release orbits will all be concentric if $\theta_{max} = -60^\circ$. But since methods of causing -60° librations usually involve $+60^\circ$ librations (which allow much larger boosts by the same tether), prograde releases may usually be preferable unless concentric orbits are needed or other constraints enter in.

NOTES

The relative tether length, mass, peak tension, and energy absorbed by the deployer brake during deployment as a function of (prograde) libration angle are all shown in the plot at right. Libration has a large effect on brake energy. This may be important when retrieval of a long tether is required, after release of a payload or after tethered-capture of a free-flying payload.

The double boost-to-escape operation at right was proposed by A. Cutler. It is shown simply as an example that even though momentum transfer is strictly a "zero sum game", a tethered release operation can be a "WIN-win game" (a large win & a small one). The small win on the deboost-end of the tether is due to the reduced gravity losses 1/2 orbit after release, which more than compensate for the deboost itself. Another example is that deboosting the shuttle from a space station can reduce both STS-deboost & station-reboost requirements.

Rendezvous of a spacecraft with the end of a tether may appear ambitious, but with precise relative-navigation data from GPS (the Global Positioning System) it may not be difficult. The relative trajectories required are simply a time-reversal of relative trajectories that occur after tether release. Approach to a hanging-tether rendezvous is shown at right. Prompt capture is needed with this technique: if capture is not achieved within a few minutes, one should shift to normal free-fall techniques. Tethered capture has large benefits in safety (remoteness) and operations (no plume impingement; large fuel savings). The main hazard is collision, due to undetected navigation or tether failure.

REFERENCES

1. G. Colombo, "Orbital Transfer & Release of Tethered Payloads," SAO report on NASA Contract NAS8-33691, March 1983.
2. W.D. Kelly, "Delivery and Disposal of a Space Shuttle External Tank to Low Earth Orbit," J. of the Astronaut. Sci., Vol. 32, No. 3, July-Sept 1984.
3. J.A. Carroll, "Tether-Mediated Rendezvous," report to Martin Marietta on Task 3 of contract RH3-393855, March 1984.
4. J.A. Carroll, "Tether Applications in Space Transportation", IAF 84-438, at the 35th IAF Congress, Oct 1984. To be published in ACTA ASTRONAUTICA.

Orbit Transfer by Tethered Release or Capture

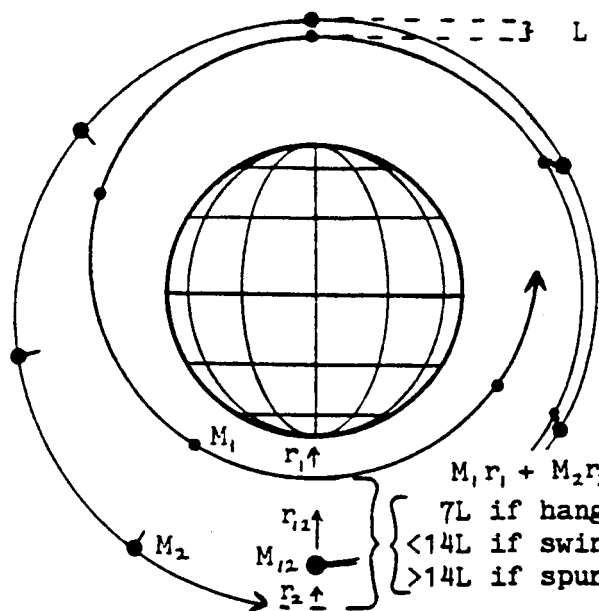

$M_1 r_1 + M_2 r_2 = M_{12} r_{12}$
 $7L$ if hanging release
 $< 14L$ if swinging release
 $> 14L$ if spun or winched

Effects of Tether Deployment and Release

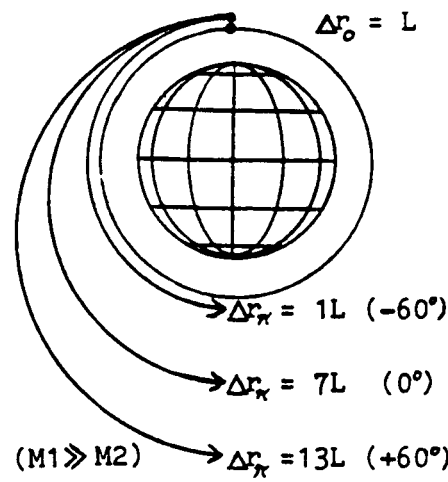

$$\Delta r_{\pi} \approx L * (7 + \sqrt{48} \sin \theta_{max})$$

Effect of Libration on Boost (release at middle of swing)

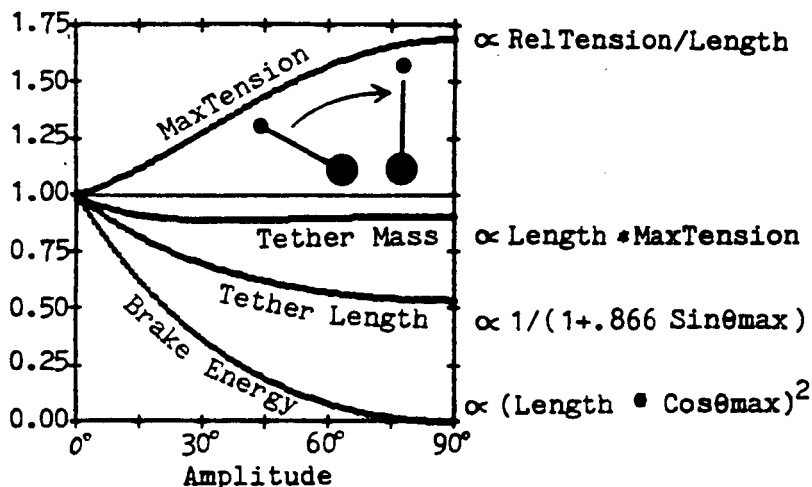

Effects of Libration (for equal- Δa boosts)

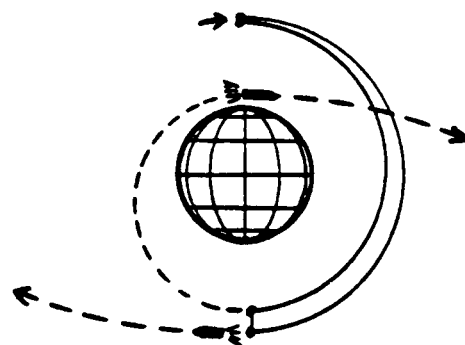

If done right, a tether boost/deboost operation can reduce ΔV -to-escape for both end masses!

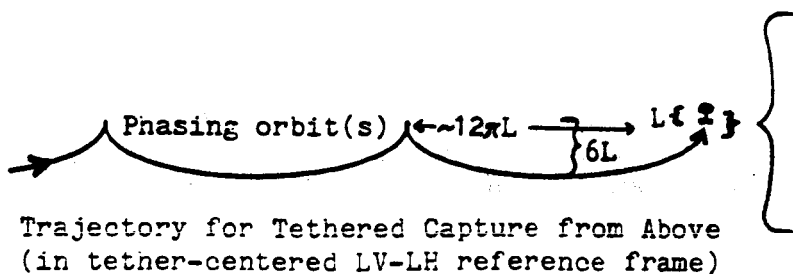

Trajectory for Tethered Capture from Above (in tether-centered LV-LH reference frame)

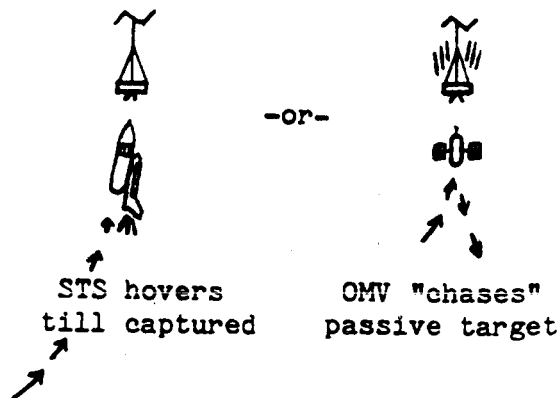

KEY POINTS

Tether operations cause higher-order repartitions of energy & angular momentum. First-order approximations that neglect these effects may cause large errors. Extremely long systems have strange properties such as positive orbital energy.

The question and answer at right are deceptively simple. The extent to which this is so, and the bizarre effects which occur in extreme cases, can be seen in the 3 graphs at right. At top, deploying & retrieving two masses on a very long massless tether changes not only the top & bottom orbital radii but also that of the CM. In addition, the free-fall location drops below the CM. Other key parameter changes under the same conditions are plotted underneath.

Note that when the tether length exceeds about 30% of the original orbital radius, the entire system lies below the original altitude. Also, at a radius ratio near 1.95:1, the maximum tether length compatible with a circular orbit is reached. At greater lengths (and the initial amount of angular momentum), no circular orbit is possible at any altitude.

Tether retrieval at the maximum-length point can cause the system to either rise or drop, depending on the system state at that time. If it continues to drop, there is a rapid rise in tether tension, and the total work done by the deployer quickly becomes positive. This energy input eventually becomes large enough (at 2.89:1) to even make the total system energy positive. The system is unstable beyond this point: any small disturbance will grow and can cause the tether system to escape from the body it was orbiting. (See ref. 2.)

NOTES

The case shown is rather extreme: except for orbits around small bodies such as asteroids, tethers either will be far shorter than the orbital radius, or will greatly outweigh the end masses. Either change greatly reduces the size of the effects shown. The effects on arbitrary structures can be calculated using the equations listed at right, which are based on a generalization of the concept of "moments" of the vertical mass distribution. Changes in tether length or mass distribution leave h unchanged, so other parameters (including r_{cm} , n , and E) must change. (For short tethers, the changes scale roughly with the square of the system's radius of gyration.) In many cases different conditions are most easily compared by first finding the orbital radius that the system would have if its length were reduced to 0, $r_{L_t}=0$.

The mechanism that repartitions energy and angular momentum is that length changes cause temporary system displacements from the vertical. This causes both torques and net tangential forces on the system, which can be seen by calculating the exact net forces and couples for a non-vertical dumbbell. The same effect occurs on a periodic basis with librating dumbbells, causing the orbital trajectory to depart slightly from an elliptical shape.

Other topics which are beyond the scope of this guidebook but whose existence should be noted are: eccentricity changes due to deployment, orbit changes due to resonant spin/orbit coupling, and effects of 2- & 3-dimensional structures.

REFERENCES

1. G. Colombo, M. Grossi, D. Arnold, & M. Martinez-Sanchez, "Orbital Transfer and Release of Tethered Payloads," continuation of NAS8-33691, final report for the period Sept 1979—Feb 1983, Smithsonian Astrophysical Observatory, March 1983. (in particular, see the table on page 21)
2. D. Arnold, "Study of an Orbiting Tethered Dumbbell System Having Positive Orbital Energy," addendum to final report on NAS8-35497, SAO, Feb 1985.

Energy & Momentum Balance

Question: What are the sources of the dumbbell spin angular momentum and deployer brake energy?

Answer: Orbit changes which repartition h & E .

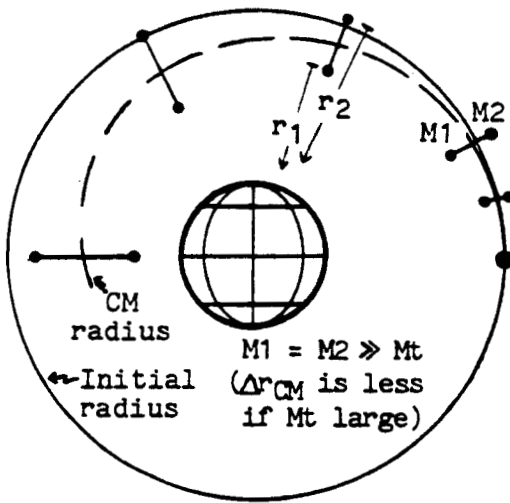

For arbitrary nearly-one-dimensional vertical structures in circular orbit, analysis can be based on 5 "moments":

$$I_N = \sum M_i r_i^N \quad (\text{for } N: -2..2)$$

Each of these has physical meaning:

$$F_{\text{grav}} = \mu I_{-2}$$

$$E_{\text{pot}} = -\mu I_{-1}$$

$$\text{Mass} = I_0$$

$$F_{\text{cen}} = n^2 I_1$$

$$h_{\text{tot}} = n I_2$$

$$E_{\text{kin}} = .5n^2 I_2$$

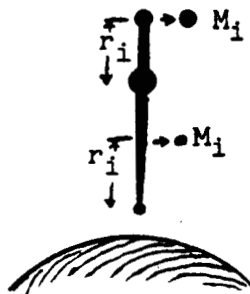

Some other useful equations include:

$$r_{\text{cm}} = I_1/I_0$$

$$n^2 = \mu I_{-2}/I_1$$

$$E = \mu ((.5I_{-2} * I_2/I_1) - I_{-1})$$

$$r_{(L_t=0)} = I_{-2}(I_2)^2/(I_1 * (I_0)^2)$$

VERY-LONG-TETHER EFFECTS:

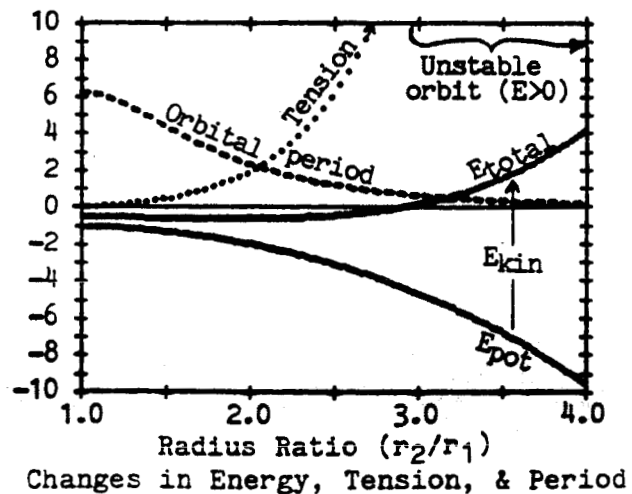
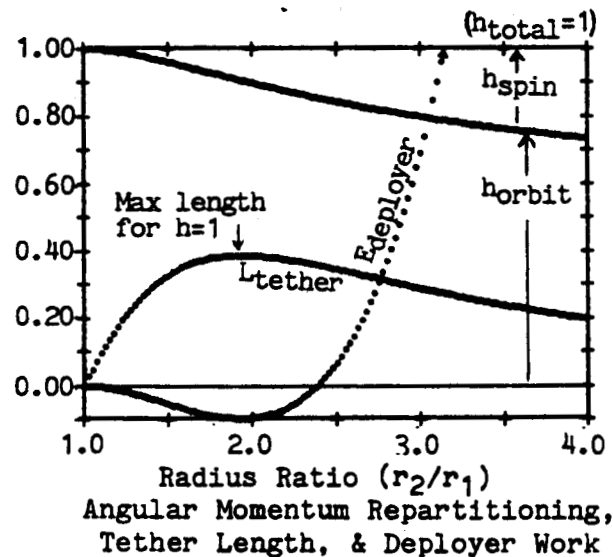
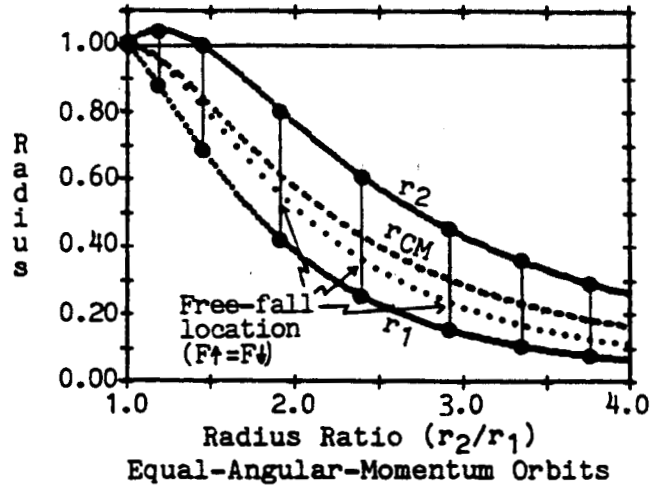

KEY POINTS

Tether strength/weight ratio constrains performance in ambitious operations. Required tether mass is easily derivable from ΔV and payload mass.

Usable specific strength can be expressed in various ways. Three ways are shown at right. V_c , L_c , and L_{1g} are here defined in terms of a typical design stress (new/m²) rather than the (higher) ultimate stress. Including the safety factor here streamlines the subsequent performance calculations. Higher safety factors are needed with non-metals than with metals since non-metals are often more variable in their properties, brittle, abrasion-sensitive, and/or creep-sensitive. A safety factor of 4 (based on short-term fiber strength) is typical for Kevlar, but the most appropriate safety factor will vary with the application.

The "characteristic velocity," V_c , is the most useful parameter in tether-boost calculations, because the tether mass can be calculated directly from $\Delta V/V_c$, independently of the orbit, and nearly independently of the operation. The table at the bottom, which lists tether/rocket combinations that have the lowest life-cycle mass requirements, holds whenever $kV_c=1$ km/sec & $I_{sp}=350$ sec.

NOTES

The characteristic length L_c is useful in hanging-tether calculations. It varies with the orbital rate n . (The simple calculation given assumes $L \ll r$; if this is not true, $1/r$ effects enter in, and calculations such as those used in refs 3-5 must be used.) The safe 1-gee length L_{1g} is mainly useful in terrestrial applications, but is included since specific strength is often quoted this way. (Note that V_c and L_c vary with $\sqrt{\text{strength}}$, and L_{1g} directly with strength.)

The specific modulus is of interest because it determines the speed of sound in the tether (C =the speed of longitudinal waves), the strain under design load ($\Delta L/L = \{V_c/C\}^2$), & the recoil speed after failure under design load ($= V_c^2/C$).

Tether mass calculations are best done by considering each end of the tether separately. If $M_{p1} \gg M_{p2}$, then M_{t1} can be neglected in preliminary calculations.

Du Pont's Kevlar is the highest-specific-strength fiber commercially available. Current R&D efforts on high-performance polymers indicate that polyester can exhibit nearly twice the strength of Kevlar.² Two fiber producers have already announced plans to produce polymers with twice the specific strength of Kevlar.

In the long run, the potential may be greater with inorganic fibers like SiC & graphite. Refs. 3-5 focus on the requirements of "space elevators." They discuss laboratory tests of single-crystal fibers and suggest that 10-fold improvements in specific strength (or 3-fold in V_c & L_c) are conceivable.

REFERENCES

1. Characteristics and Uses of Kevlar 49 Aramid High Modulus Organic Fiber. available from Du Pont's Textile Fibers Department, 1978.
2. G. Graff, "Superstrong Plastics Challenge Metals," High Technology magazine, February 1985, pp. 62-63.
3. J. Isaacs, H. Bradner, G. Backus, and A. Vine, "Satellite Elongation into a True "Skyhook"; a letter to Science, Vol. 151, pp. 682-683, Feb 11, 1966.
4. J. Pearson, "The Orbital Tower: a Spacecraft Launcher Using the Earth's Rotational Energy," Acta Astronautica, Vol. 2, pp. 785-799, Pergamon, 1975.
5. H. Moravec, "A Non-Synchronous Orbital Skyhook," J. of the Astronautical Sciences, Vol. XXV, No. 4, pp. 307-322, Oct-Dec 1977.

Specific Strength and Required Tether Mass

ORIGINAL PAGE IS
OF POOR QUALITY

$C = \text{speed of sound} = \sqrt{\frac{\text{modulus}}{\text{density}}}$

TETHER STRENGTH PARAMETERS	
$\sqrt{\frac{\text{design stress}^*}{\text{density}}}$	= Char. vel = V_c
$V_c/\sqrt{3n}$	= Char. length = L_c
V_c^2/g	= Safe 1g length = L_{1g}

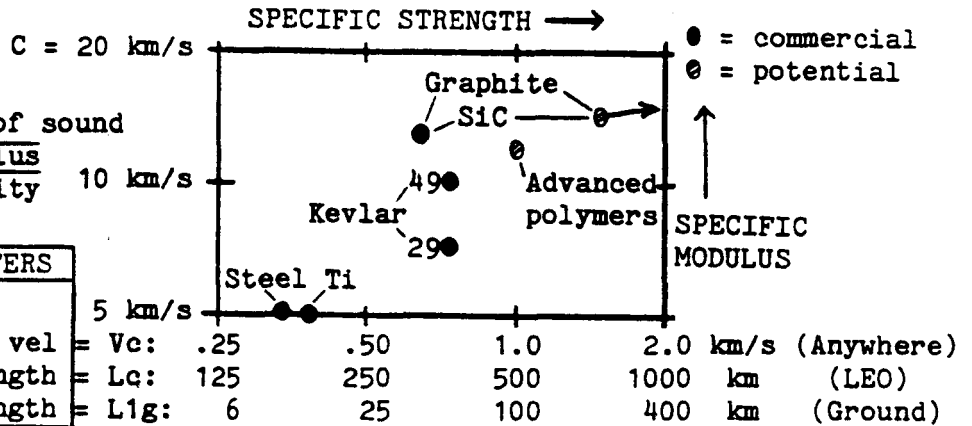

* Design stress is assumed to be 1/2 the ultimate strength for metals and 1/4 the short-term individual fiber strength for other materials.

SPECIFIC STRENGTH & MODULUS OF SEVERAL TETHER MATERIALS

Gaussian "normal" bell-shaped curve (if $L_c \ll L \ll r$)

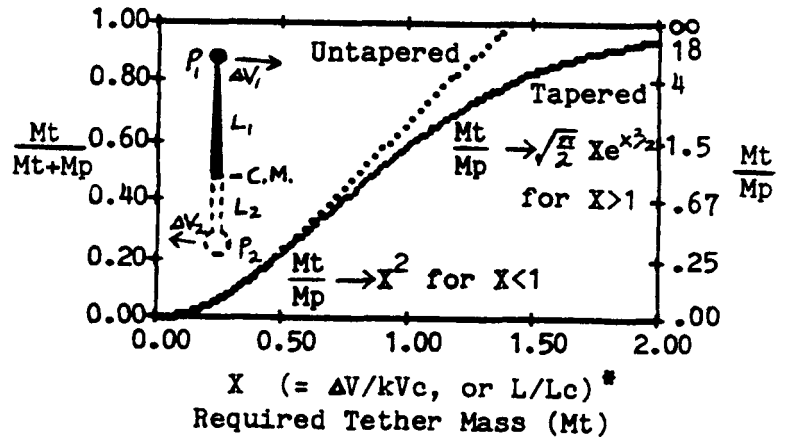
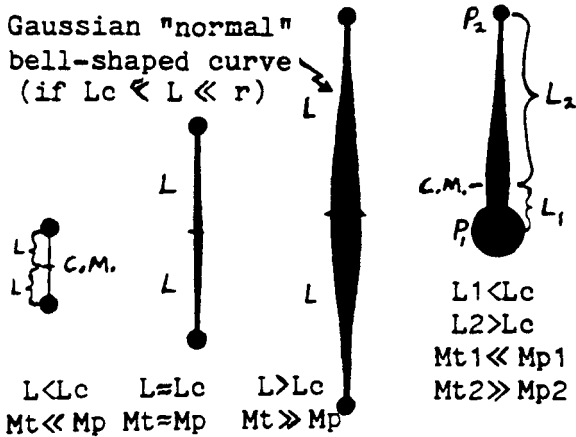

* $k = \begin{cases} 1.00 & \text{for spinning operations} \\ 1.15 & \text{for hanging " } \\ 1.21 \pm 0.01 & \text{for swinging " } \\ 1.41 & \text{for winching " } \end{cases}$

$\Delta V = \text{Sum of perigee + apogee boosts}$

Tether Length & Required Mass

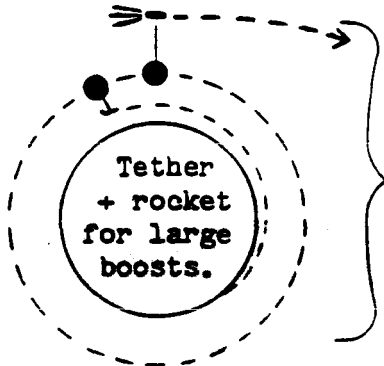

Expected # of uses	1	10	100	1000
Best tether ΔV , km/s	.14	.9	1.8	2.6
Required M_t/M_p	.02	1	11	95

(For $kV_c = 1 \text{ km/s}$ and rocket $I_{sp} = 350 \text{ seconds}$; marginal deployer & dry rocket masses neglected.)

Best Tether ΔV for Combined Tether/Rocket Boosts

KEY POINTS

Micrometeoroids can sever thin tethers & damage tether protection/insulation. Orbiting debris (or other tethers) can sever tethers of any diameter. Debris could impact an Earth-based "Space Elevator" over once per year.

Sporadic micrometeoroids are usually assumed to have an typical density of about .5 and a typical impact velocity in LEO of approximately 20 km/sec.¹ At impact speeds above the speed of sound, solids become compressible and the impact shock wave has effects like those of an explosion. For this reason, the risk curve assumes that if the EDGE of an adequately large meteoroid comes close enough to the center of the tether (within 45° or $.35 Dt$), failure will result.

Experiments done by Martin Marietta on TSS candidate materials have used glass projectiles fired at 6.5 km/sec, below the (axial) speed of sound in Kevlar. Two damaged tethers from those tests are shown at right. The scaling law used ($\rho \cdot v^{.67}$) indicates that this is representative of orbital conditions, but that law (used for impacts on sheet metal) may not apply to braided fibers.

NOTES

For tethers much thicker than 10 mm or so (depending on altitude), the risk does not go down much as Dt increases, because even though the micrometeoroid risk still decreases, the debris risk (which INCREASES slightly with Dt) begins to dominate. As with micrometeoroids, the tether is assumed to fail if any part of the debris passes within $.35 Dt$ of the center of the tether.

The debris risk at a given altitude varies with the total debris width at that altitude. This was estimated from 1983 CLASSEY radar-cross-section (RCS) data, by simply assuming that $W = \text{Sqrt}(\text{RCS})$ and summing $\text{Sqrt}(\text{RCS})$ over all tracked objects in LEO.⁶ This underestimates W for objects with appendages, and overestimates it for non-librating elongated objects without appendages.

CLASSEY RCS data are expected to be accurate for $\text{RCS} > 7 \text{ m}^2$. The 700 objects with $\text{RCS} > 7 \text{ m}^2$ account for 3 km of the total 5 km width, so errors with smaller objects are not critical. Small untracked objects may not add greatly to the total risk: 40,000 objects averaging 2 cm wide would increase the risk to a 1-cm tether by only 20%. \bar{W} was assumed independent of altitude, so the distribution of risk with altitude could be estimated by simply scaling Figure 1 from Ref. 4.

As shown at right, debris impact with a space elevator could be expected more than once per year at current debris populations. The relative density at 0° latitude was estimated from data on pp. 162-163 of ref. 6.

Similar calculations can be made for two tethers in different orbits at the same altitude. If at least one is spinning or widely librating, the mutual risks can exceed .1 cut/km.yr. This makes "tether traffic control" essential.

REFERENCES

1. Meteoroid Environment Model—1969 [Near Earth to Lunar Surface], NASA SP-8013, March 1969.
2. Meteoroid Environment Model—1970 [Interplanetary and Planetary], NASA SP-8038, October 1970.
3. Meteoroid Damage Assessment, NASA SP-8042, May 1970. (Shows impact effects)
4. D.J. Kessler, "Sources of Orbital Debris and the Projected Environment for Future Spacecraft", in J. of Spacecraft & Rockets, Vol 18 #4, Jul-Aug 1981.
5. D.J. Kessler, Orbital Debris Environment for Space Station, JSC-20001, 1984.
6. CLASSY Satellite Catalog Compilations as of 1 Jan 1983, NORAD/J5YS, 1983.

Impact Hazards for Tethers

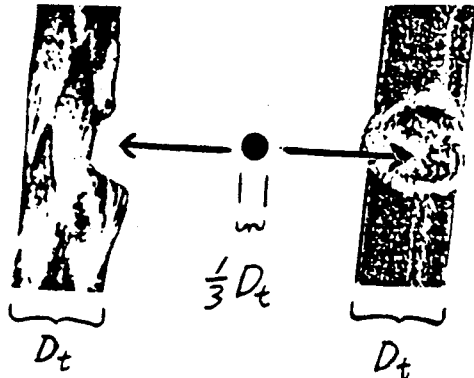

Braided Kevlar, grazed

Stainless steel wire, direct hit

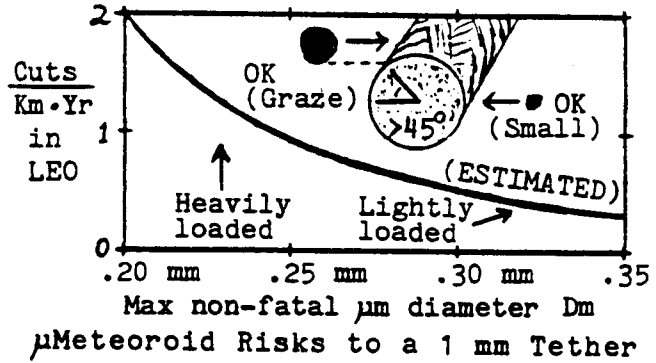

For tethers with $D_t > 1$ (mm),
& Max non-fatal $D_m = .25 D_t$,

$$\frac{\mu\text{m cuts}}{\text{Km}\cdot\text{Yr}} \approx D_t^{-2.6}$$

Effective Width, W
(Any position between the 2 extremes shown cuts the tether.)

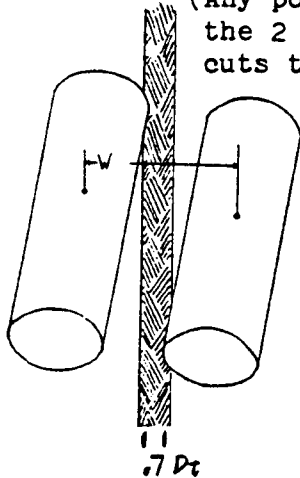

ORIGINAL PAGE IS
OF POOR QUALITY

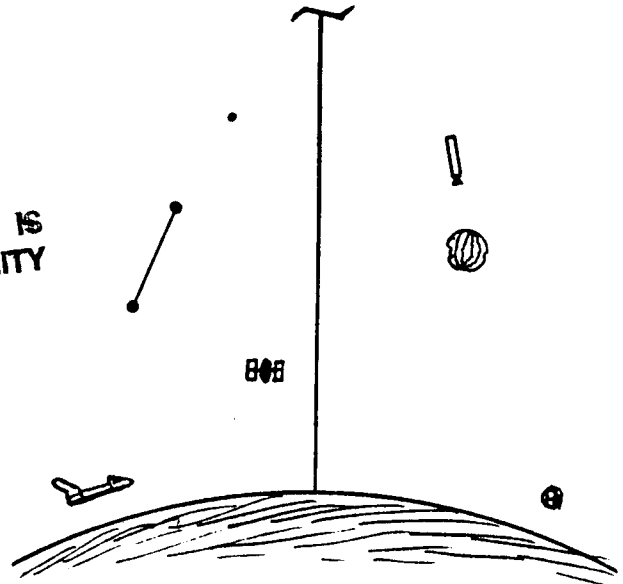

Debris Risk to the Lowest 4000 km
of an Earth-based Space Elevator:

$$\begin{aligned} \text{Risk} &= \frac{\Sigma \text{Width} \cdot \bar{V} \cdot \text{RelDensity at } \lambda=0}{\text{Earth "Surface Area" at Alt}} \\ &= \frac{\sim 5 \text{ km} \cdot \sim 7.3 \text{ km/sec} \cdot \sim .72}{4 \cdot \pi \cdot \text{Sqr}(\sim 7378 \text{ km})} \\ &\approx 3.9\text{E-}8/\text{sec} \approx \boxed{1.2 \text{ cuts/year}} \end{aligned}$$

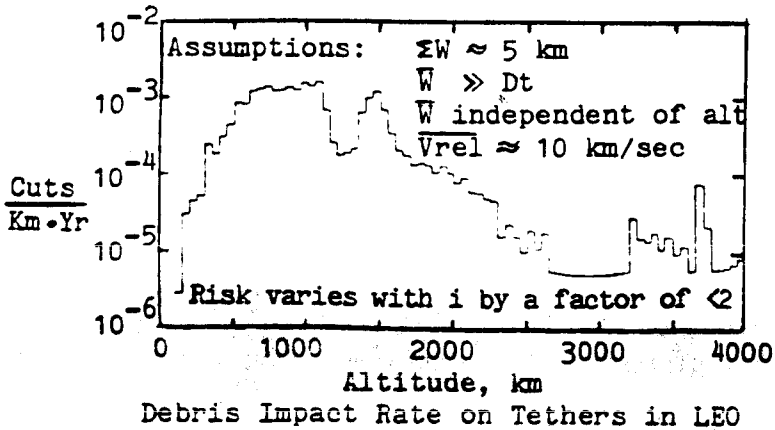

Debris Impact Rate on Tethers in LEO

KEY POINTS

Tether (& other) resistance can limit the output of electrodynamic tethers. Electron collection methods & effectiveness are important—and uncertain.

Since the publication of ref. 1, 20 years ago, electrodynamic tether proposals and concepts have been a frequent source of controversy, mainly in these areas:

1. What plasma instabilities can be excited by the current?
2. What is the current capacity of the plasma return loop?
3. What is the best way to collect electrons from the plasma?

The first Tethered Satellite mission may do much to answer these questions. The discussion below and graphics at right merely seek to introduce them.

The current flowing through an electrodynamic tether is returned in the surrounding plasma. This involves electron emission, conduction along the geomagnetic field lines down to the lower ionosphere, cross-field conduction by collision with neutral atoms, and return along other field lines.

The tether current causes a force on the tether (and on the field) perpendicular to both the field and the tether (horizontal, if the tether is vertical). Motion of the tether through the geomagnetic field causes an EMF in the tether. This allows the tether to act as a generator, motor, or self-powered ultra-low-frequency broadcast antenna.² The motion also causes each region of plasma to experience only a short pulse of current, much as in a commutated motor.

Based on experience with charge neutralization of spacecraft in high orbit, it has been proposed that electrons be collected by emitting a neutral plasma from the end of the tether, to allow local cross-field conduction.³ In GEO, the geomagnetic field traps a plasma in the vicinity of the spacecraft, and "escape" along field lines may not affect its utility. This may also hold in high-inclination orbits in LEO. But in low inclinations in LEO, any emitted plasma might be promptly wiped away by the rapid motion across field lines.

A passive collector such as a balloon has high aerodynamic drag, but a end-on sail can have an order of magnitude less drag. The electron-collection sketch at bottom right is based on a preliminary analysis by W. Thompson.⁵ This analysis suggests that a current moderately higher than the electron thermal current ($=Ne * \sim 200$ km/sec) might be collected on a surface normal to the field. This is because collecting electrons requires that most ions be reflected away from the collection region as it moves forward. This pre-heats and densifies the plasma ahead of the collector. The voltage required for collection is just the voltage needed to repel most of the ions, about 12 V.

NOTES

REFERENCES

1. S.D. Drell, H.M. Foley, & M.A. Ruderman, "Drag and Propulsion of Large Satellites in the Ionosphere: An Alfvén Propulsion Engine in Space," J. of Geophys. Res., Vol. 70, No. 13, pp. 3131-3145, July 1965.
2. M. Grossi, "A ULF Dipole Antenna on a Spaceborne Platform of the PPEPL Class," Report on NASA Contract NAS8-28203, May 1973.
3. R.D. Moore, "The Geomagnetic Thruster—A High Performance "Alfvén Wave" Propulsion System Utilizing Plasma Contacts," AIAA Paper No. 66-257.
4. S.T. Wu, ed., University of Alabama at Huntsville/NASA Workshop on The Uses of a Tethered Satellite System, Summary Papers, Huntsville AL, May 1978. See papers by M. Grossi et al, R. Williamson et al., and N. Stone.
5. W. Thompson, "Electrodynamic Properties of a Conducting Tether," Final Report to Martin Marietta Corp. on Task 4 of Contract RH3-393855, Dec. 1983.

Electrodynamic Tether Principles

ORIGINAL PAGE IS OF POOR QUALITY

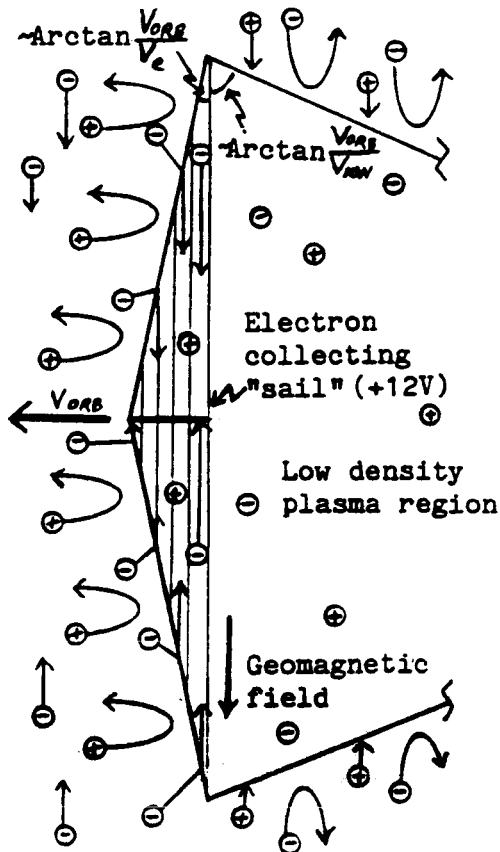
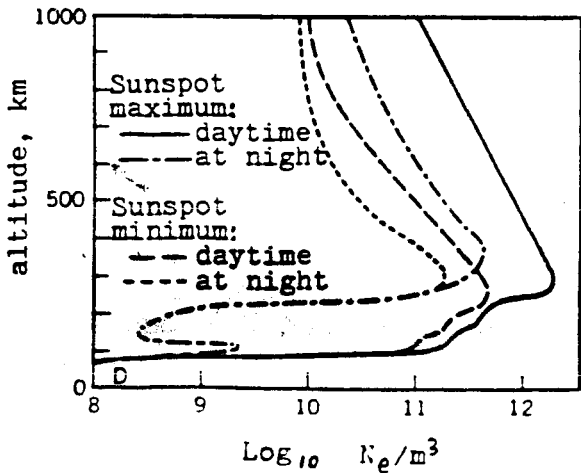
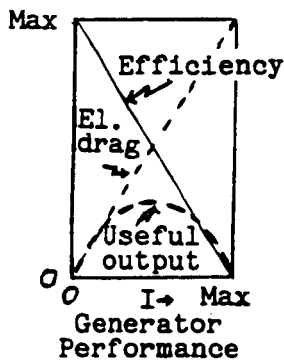
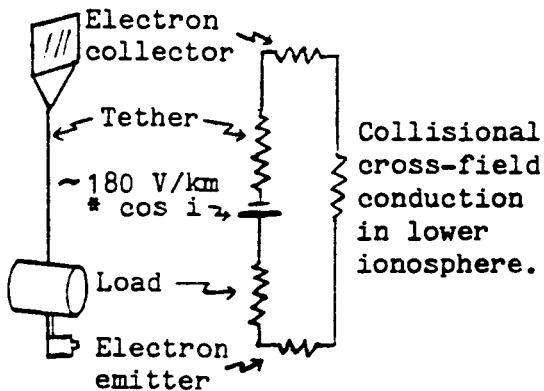
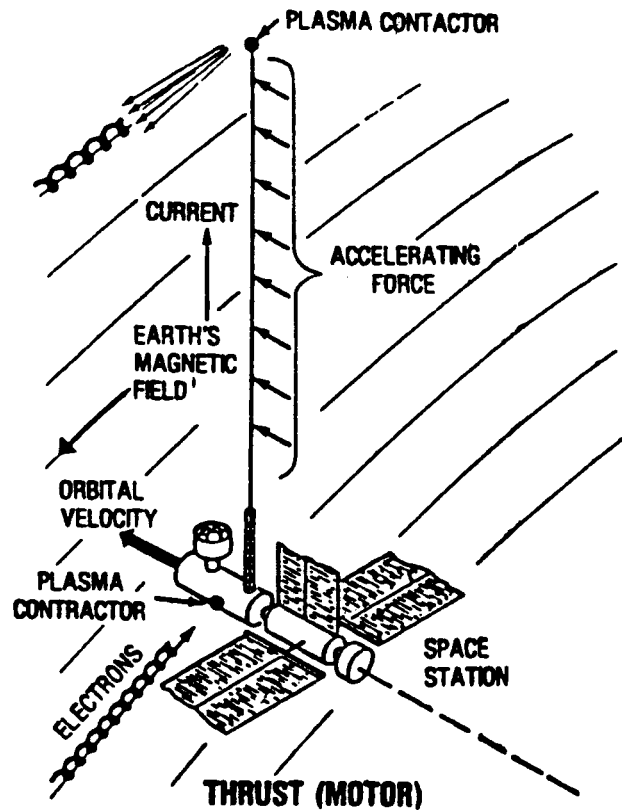
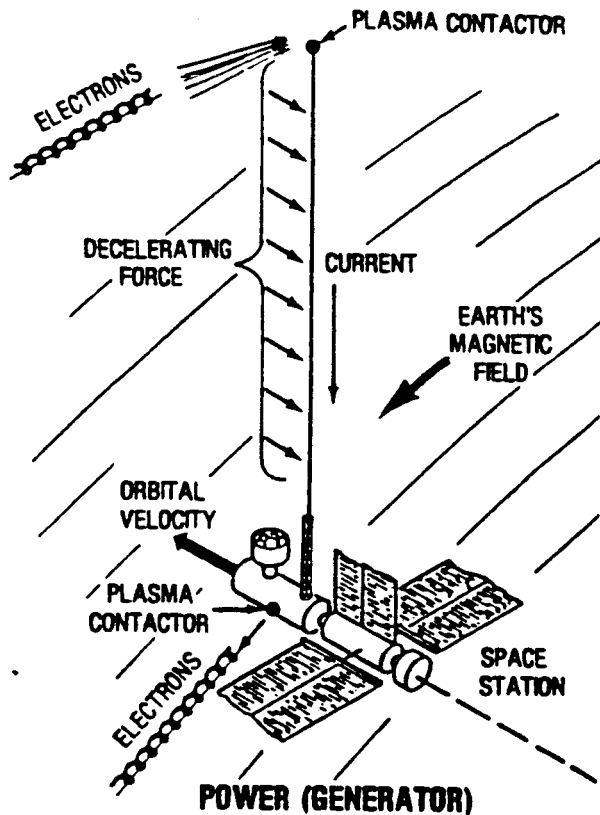

Top View of Electron Collection

KEY POINTS

Electrodynamic tether use will affect the orbit—whether desired or not. Stationkeeping and/or large orbit changes without propellant use are possible.

The offset dipole approximation shown at right is only a first approximation to the geomagnetic field: harmonic analyses of the field give higher-order coefficients up to 20% as large as the fundamental term. Ref. 1 contains computerized models suitable for use in detailed electrodynamic studies.

The geomagnetic field weakens rapidly as one moves into higher orbits, and becomes seriously distorted by solar wind pressure beyond GEO. However, ohmic losses in a tether are already significant in LEO, so electrodynamic tethers are mainly useful in low orbits where such distortions are not significant.

As the earth rotates, the geomagnetic field generated within it rotates also, and the geomagnetic radius and latitude of a point in inertial space vary over the day. If a maneuvering strategy which repeats itself each orbit is used (necessary unless the spacecraft has large diurnal power storage capacity), then the average effect, as shown at right, will be a due east thrust vector.

NOTES

Variations in geomagnetic latitude (and thus in B_h) cancel out variations in the component of flight motion perpendicular to the field, so these variations do not cause large voltage variations in high-inclination orbits. (Note that the relevant motion is motion relative to a rotating earth.) Out-of-plane libration, variations in geomagnetic radius, and diurnal variation of the "geomagnetic inclination" of an orbit can all cause voltage variations. Peak EMFs (which drive hardware design) may approach 400 V/km.

However these variations need not affect the thrust much if a spacecraft has a variable-voltage power supply: neglecting variations in parasitic power, constant power investment in a circular orbit has to give constant in-plane thrust. The out-of-plane thrust is provided "free" (whether desired or not). Average voltage & thrust equations for vertical tethers are shown at right.

The table shows how to change all six orbital elements separately or together. Other strategies are also possible. Their effects can be calculated from the integrals listed. For orbits within 11° of polar or equatorial, diurnally-varying strategies become more desirable. Computing their effects requires using the varying geomagnetic inclination instead of i (& moving it inside the integral). Note that the "DC" orbit-boosting strategy also affects i . This can be cancelled out by superimposing a $-2 \cos(2\phi)$ current on the DC current.

As discussed under Electrodynamic Libration Control Issues, eccentricity and apside changes can strongly stimulate ϕ -libration unless the spacecraft center of mass is near the center of the tether. Other maneuvers should not do this, but this should be checked using high-fidelity geomagnetic field models.

REFERENCES

1. E.G. Stassinopoulos & G.D. Mead, ALLMAG, GDALMG, LINTRA: Computer Programs for Geomagnetic Field & Field-Line Calculations, Feb. 1972, NASA Goddard.
2. R.D. Moore, "The Geomagnetic Thruster—A High Performance "Alfvén Wave" Propulsion System Utilizing Plasma Contacts," AIAA Paper No. 66-257.
3. H. Alfvén, "Spacecraft Propulsion; New Methods," Science, Vol. 176, 14 April 1972, pp. 167-168.

ORIGINAL PAGE IS
OF POOR QUALITY

Electrodynamic Orbit Changes

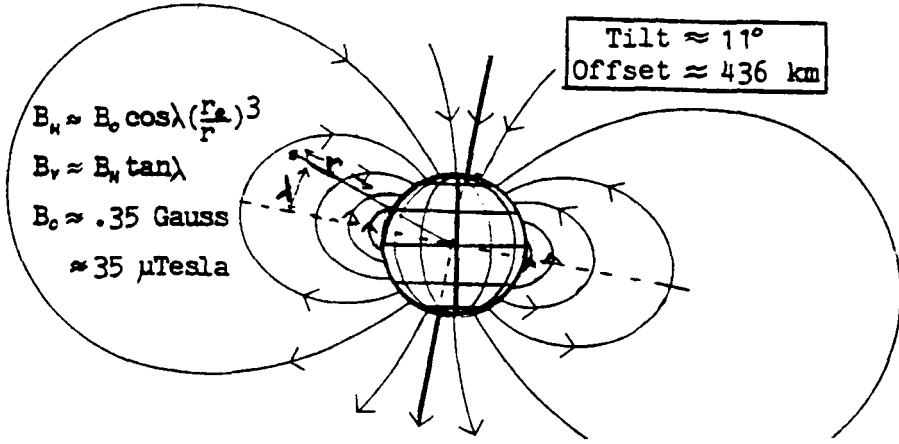

OFFSET DIPOLE APPROXIMATION TO GEOMAGNETIC FIELD

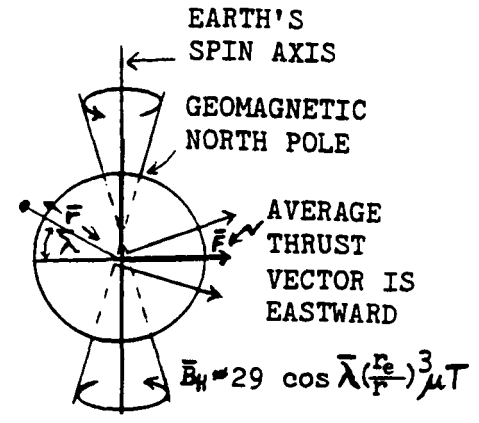

EFFECT OF EARTH'S SPIN ON TIME-AVERAGED FIELD

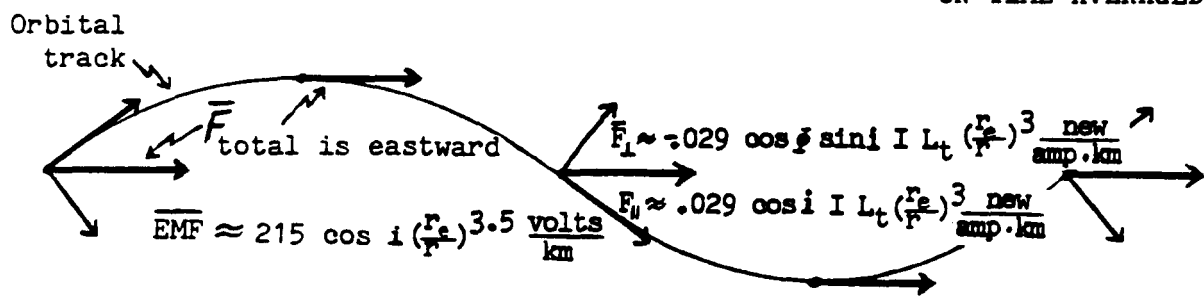

HOW TO CHANGE ORBITS USING AN ELECTRODYNAMIC TETHER

Element	Strategy	Thrust Vector	Effect
Semimajor axis	DC		$\Delta a \approx \cos(i) \frac{kl}{m} \int i dt$
Phase	Sawtooth		$\Delta \Omega \approx \cos(i) \frac{1.5 kl \eta}{ma} \int i t dt$
Eccentricity	$\cos(\theta)$		$\Delta e \approx \cos(i) \frac{kl}{ma} \int i \cos(\theta) dt$
Line of apsides	$\sin(\theta)$		$\Delta \omega \approx \cos(i) \frac{kl}{ma} \int i \sin(\theta) dt$
Inclination	$-\cos(2\phi)$		$\Delta i \approx \frac{-kl}{2ma} \int i \sin(i) \cos^2(\phi) dt$
Ascending node	$-\sin(2\phi)$		$\Delta \Omega \approx \frac{-kl}{2ma} \int i \sin(\phi) \cos(\phi) dt$

θ = POSITION OF VEHICLE WITH REFERENCE TO ITS PERIGEE
 ϕ = POSITION WITH REFERENCE TO ASCENDING NODE
 k = ~4 TONNES PER AMPERE DAY * $(r_e/r)^{1.5}$

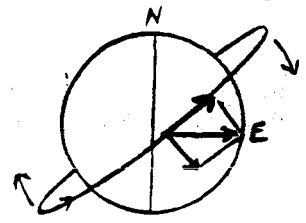

l = TETHER LENGTH
 m = TOTAL VEHICLE MASS
 η = ORBITAL ANGULAR RATE

KEY POINTS

Properly controlled AC components can be used to control θ and ϕ -libration. Solar-energy storage and e or w changes strongly stimulate ϕ -libration. AC currents other than 1 & 3/orbit should not affect ϕ -libration much.

The maneuvering strategies on the previous page have assumed that electrodynamic tethers will stay vertical. However, as shown at right, the distributed force on the tether causes bowing, and that bowing is what allows net momentum transfer to the attached masses. Note that net momentum can be transferred to the system even if the wire is bowed the wrong way (as when the current is suddenly reversed); momentum transferred to the wire gets to the masses later.

This figure also illustrates two other issues:

1. Bowing of the tether causes it to cross fewer field lines.
2. Unequal end masses and uniform forces cause overall torques & tilting.

The bowing causes the tether to provide less thrust while dissipating the same parasitic power. The net force on the system is the same as if the tether were straight but in a slightly weaker magnetic field.

The torque on the system causes it to tilt away from the vertical, until the torque is balanced by gravity-gradient restoring torques. For a given system mass and power input, disturbing torques vary with L and restoring torques with L^2 , so longer systems can tolerate higher power. The mass distribution also affects power-handling capability, as seen in the sequence at top right.

NOTES

Modulating the tether current modulates any electrodynamic torques. Current modulation at $L/73$ n can be used to control in-plane libration. Out-of-plane torques can also be modulated, but another control logic is required. This is because the once-per-orbit variation in out-of-plane thrust direction makes a current with frequency F (in cycles per orbit) cause out-of-plane forces and torques with frequencies of $F-1$ and $F+1$, as shown in the Fourier analysis at bottom right. Hence ϕ libration control ($F=2$) requires properly phased $F=1$ or $F=3$ currents. Higher frequencies can damp odd harmonics of any tether bowing oscillations. Control of both in- & out-of-plane oscillations may be possible since they have the same frequencies and thus require different currents.

Applications that require significant $F=1$ components for other reasons can cause problems. Four such strategies are shown at right. Sin & Cos controls allow adjustment of e or w . The two "Sign of ..." laws allow constant power storage over 2/3 of each orbit and recovery the rest of the orbit. These laws would be useful for storing photovoltaic output for use during dark periods.

These strategies drive out-of-plane libration (unless the center of mass is at the center of the tether). The libration frequency decreases at large amplitudes, so if the system is not driven too strongly, it should settle into a finite-but-large-amplitude phase-locked loop. This may be unacceptable in some applications, due to resulting variations in gravity or tether EMF. In some cases, such as eccentricity changes, adding a $F=3$ component might cancel the undesired effect of an $F=1$ current while keeping the desired effect.

REFERENCE

1. G. Colombo, M. Grossi, M. Dobrowolny, and D. Arnold, Investigation of Electrodynamic Stabilization & Control of Long Orbiting Tethers, Interim Report on Contract NAS8-33691, March 1981, Smithsonian Astrophysical Observatory.

Electrodynamic Libration Control Issues

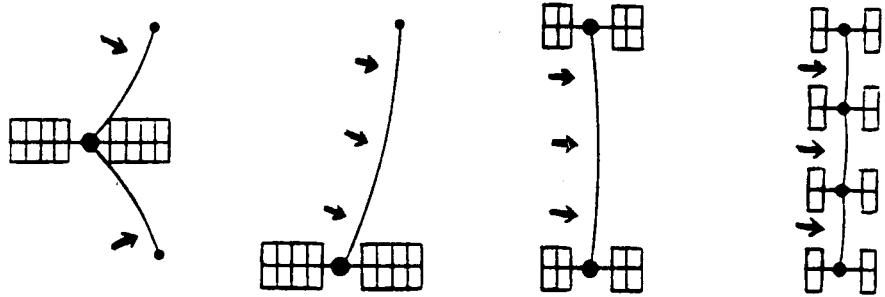
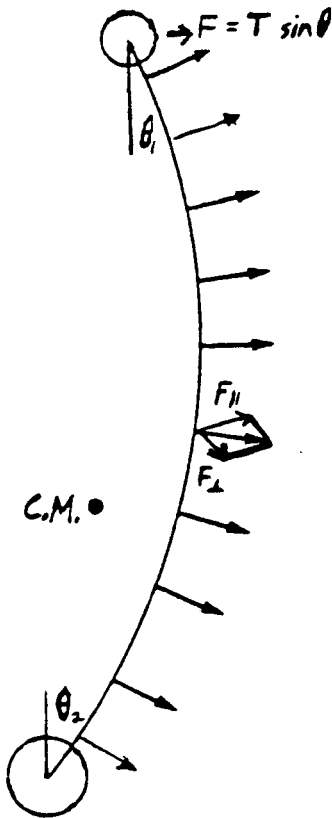

INCREASING STABILITY \longrightarrow
(for fixed total length & mass & I)

FOR CONTROL OF:	MODULATE I AT:
Out-of-plane libration*	1 n or 3 n
In-plane libration*	1.73 n
Tether oscillations	>5 n

* I or mass distribution must be lopsided

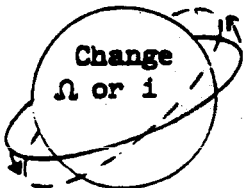
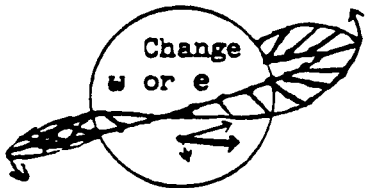
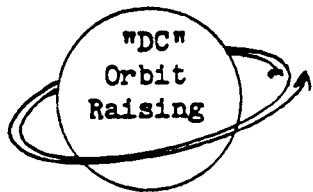

Tether Current:

$$I = 1.0$$

$$I = \sin \phi$$

$$I = \cos \phi$$

$$I = \text{Sign of } (.5 + \sin \phi)$$

$$I = \text{Sign of } (.5 + \cos \phi)$$

$$I = \sin 2\phi$$

$$I = \cos 2\phi$$

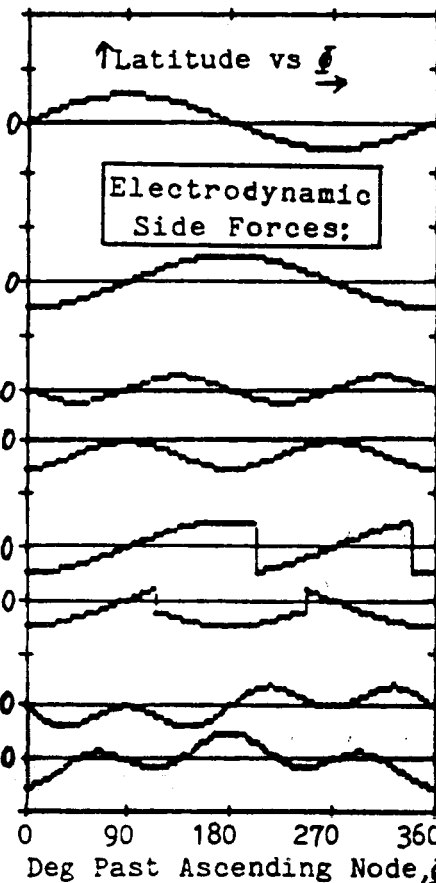

Fourier Analysis of Out-Of-Plane Forces:

	1n	2n	3n
$I = 1.0$.50	0	0
$I = \sin \phi$	0	.50*	0
$I = \cos \phi$	0	.50	0
$I = \text{Sign of } (.5 + \sin \phi)$.50	.65	.39
$I = \text{Sign of } (.5 + \cos \phi)$.03	.51	.07
$I = \sin 2\phi$.50	0	.50
$I = \cos 2\phi$.50	0	.50

* drives ϕ libration

BIBLIOGRAPHY OF SPACE-TETHER LITERATURE

The number of references listed with each topic in the body of the Guidebook was intentionally limited. A more comprehensive bibliography follows. It was compiled by merging bibliographies previously compiled by Mark Henley, Peter Swan, Georg von Tiesenhausen, and others. It will be expanded and updated in future revisions of the Guidebook.

Many references (particularly final reports) cover several topics. However they are listed here only under the most specific relevant heading. For example, transport concepts explicitly intended for use on a space station are listed under space stations. For thoroughness, check related headings.

BIBLIOGRAPHY HEADINGS:

- General
- The Tethered Satellite System
- Space Station & Constellation Applications
- Transportation
- Electrodynamics
- Dynamics, Controls, & Simulations (incl. TSS)
- Beanstalks and Other Ambitious Concepts
- Tether Materials

SOME FREQUENTLY OCCURRING ABBREVIATIONS:

- CSI = California Space Institute, SIO/UCSD, La Jolla CA
- IAF = International Astronautical Federation
- JSC = Johnson Space Center, Houston TX
- MSFC = Marshall Space Flight Center, Huntsville AL
- SAO = Smithsonian Astrophysical Observatory, Cambridge, MA

GENERAL

—, Applications of Tethers in Space, Vol. 1 & 2, Workshop Proceedings, 15-17 June 1983.

—, Proposed 1984-1987 Program Plan for Tether Applications in Space, prepared by NASA Tether Applications in Space Task Group, Sept 1983.

—, Selected Tether Applications in Space—An Analysis of 5 Selected Concepts, July 31, 1984, Martin Marietta final report, NASA Contract NAS 8-35499.

—, Selected Tether Applications in Space— Phase II, Preliminary Draft of Final Report on NASA Contract NAS 8-35499, Martin Marietta, February 1985.

—, Movies for Gemini Missions XI and XII, available from Public Affairs Office, AP2, NASA JSC, Houston TX 77058. (See tether-experiment sequences.)

Bekey, Ivan, Tethers Open New Space Options, *Astronautics & Aeronautics*, April 1983. Reprint available from OSF, MT-3, NASA Headquarters, Wash. D.C. 20546.

Carroll, J., Some Tether-Related Research Topics, prepared under JPL contract LC 778278 for the NASA Tether Applications in Space Task Force, November 1984.

Lang, D.D., and R.K. Nolting, "Operations with Tethered Space Vehicles," in Proceedings of the Gemini Summary Conference, NASA SP-138, 1967.

Laue, J., U.S./Italian Discussion on Tether-Related Activities at NASA Headquarters, NASA/MSFC, Nov.18, 1982.

Von Tiesenhausen, G., Tethers in Space-Birth and Growth of a New Avenue to Space Utilization, Feb. 1984. NASA-TM-82571, NASA/MSFC.

THE TETHERED SATELLITE SYSTEM

—, Shuttle Tethered Satellite System Design Study, NASA TM X-73365, MSFC, 1976.

—, Shuttle Tethered Satellite System Definition - Final Study Report, NAS8-32854, Martin Marietta Aerospace, April 1979.

—, Shuttle Tethered Satellite System Definition - Final Study Report, NAS8-32853, Ball Aerospace Systems Division, April 1979.

—, Shuttle Tethered Satellite System, Final Report from the Facility Requirements Definition Team; sponsored by MSFC under NASA Contract NAS8-33383 to the Center for Atmospheric and Space Sciences, Utah State Univ., May 1980.

—, TSS Final Review, Martin Marietta presentation at MSFC, Dec 14-15, 1982.

Arnold, D., G. Colombo, N. Hanham, and G. Nystom, System Noise Analysis of the Dumbbell Tethered Satellite for Gravity-Gradient Measurements, final report on NASA grant NSG-8063, 1979.

Baker, W., J.A. Dunkin, Z.J. Galaboff, K.D. Johnson, R.R. Kissel, M.H. Rhein-furth and M.P.L. Siebel, Tethered Subsatellite Study, NASA TM X-73314, MSFC, March 1976.

Colombo, G., E.M. Gaposchkin, M.D. Grossi, and G.C. Weiffenbach, "The Skyhook": A Shuttle-Borne Tool for Low Orbital Altitude Research", MECCANICA, March 1975.

Colombo, G., E.M. Gaposchkin, M.D. Grossi, and G.C. Weiffenbach, "Long Tethered Satellites for the Shuttle Orbiter", presented at the International Conference on Technology of Scientific Space Experiments, Paris, France, May 1975.

Colombo, G., E.M. Gaposchkin, M.D. Grossi, and G.C. Weiffenbach, "Shuttle-borne Long-tethered Satellites, A New Tool for Low Cost Space Science & Applications", presented at AAS/AIAA Conference, Nassau, Bahamas, July 1975.

Colombo, G., D. Arnold, J. Binsack, R. Gay, M. Grossi, D. Lautman, and O. Orringer, Dumbbell Gravity-Gradient Sensor: A New Application of Long Tethers, SAO Reports in Geoastronomy, no. 2, 1976.

Colombo, G., E. Gaposchkin, M. Grossi, and G. Weiffenbach, Gravity-Gradient Measurements down to 100 km Height by Means of Long Tethered Satellites, presented at 27th IAF Congress, Anaheim CA, Oct 1977.

G. Colombo, D. Arnold, E. Gaposchkin, M. Grossi, P. Kalaghan, and L. Kirschner, Tethered Satellite System for Gravity Gradiometry at Low Orbital Height, presented at the Earth Dynamics Summer Workshop, Boulder CO, July 1977.

Colombo, G., et al., "Satellite Connected by Means of a Long Tether to a Powered Spacecraft," US Patent 4,097,010. June 27, 1978.

Colombo, G., S. Bergamaschi, and F. Bevilacqua, "The Italian Participation to the Tethered Satellite System", IAF #81-33, 32nd IAF Congress, Sept 1981.

Crouch, Donald S., "Shuttle Tethered Satellite System Program Overview", Applications of Tethers in Space Workshop, Williamsburg, Va., June 15, 1983.

Laue, Jay H., "Tethered Satellite System-Project Overview", Briefing given NASA/MSFC/PF17, Jan 19, 1983.

Laue, J.H. and F. Manarini, "The Tethered Retrievable Platform Concept and Utilization", IAF-82-13, 33rd IAF Congress, Sept-Oct 1982, Paris France.

Lundquist, C., and G. Colombo, "Advanced Technologies in Space and Opportunities for Gravity Experiments", presented at the International School of Relativistic Astrophysics, Trapani, Italy, Fall 1977.

Manarini, G. and F. Mariani, "The Tethered Satellite System Technical Aspects and Prospective Science Missions", Rienna, Atti 22 Convegno Intele Sullo Spazio, Roma 1982.

Mariani, F., "Science by Tethered Satellite", Dipartimento di Fisica, Universita di Roma "La Sapienza", Piazzale Aldo Moro, 2-00185, Roma, Italy.

Merlina, P., Double Tethered Satellite System, Nov. 23, 1982, Aeritalia-Settore Spazio.

Rupp, C.C. and J.H. Laue, "Shuttle/Tethered Satellite System", Journal of Astronautical Sciences, Vol. 26, No. 1, Jan 1978, p. 1-17.

Snoddy, W.C., "Scientific and Technical Applications of a Tethered Satellite System," AIAA Aerospace Sciences Meeting, New Orleans, La., Jan 15-17, 1979.

Wu, S.T., ed., University of Alabama at Huntsville/NASA Workshop on The Uses of a Tethered Satellite System, Summary Papers, Huntsville AL, May 1978.

SPACE STATION AND CONSTELLATION APPLICATIONS

—, Space Station Requirements for Tether Applications, July 26, 1984, Martin Marietta final report, NASA Contract NAS 8-35499.

Arnold, J.R., et al, The Process of Space Station Development Using External Tanks, Report to the Office of Technology Assessment, March 1983. CSI.

Carroll, J.A., Tether Mediated Rendezvous, report to Martin Marietta on Task 3 of contract RH3-393855, March 1984, CSI.

Carroll, J.A., A Scenario for Tether Uses in a Space Station, AIAA/NASA Space Systems Technology Conference Paper 84-1110-CP. Costa Mesa, June 5, 1984, CSI.

Colombo, G., A Preliminary Study of the Orbiting Platform-Tether System Space Operation Center, MIT Dept. of Aeronautics and Astronautics, 1980.

Colombo, G., A Straightforward Use of the Shuttle ET, presented at the Workshop on the Utilization of the External Tanks of the STS, 1982, CSI.

Colombo, G., and J. Slowey: On a New Concept for a Space Station Architecture, Appendix II of Report on the Utilization of the External Tanks of the STS, CSI, April 1983.

Colombo G., A New Tethered Dual Platform Space Station Concept, Oct, 1983, NASA Contract G 82678-3286, SAO.

English, R., Characteristics of a Tethered Space Station, NASA LeRC, Oct. 21, 1983.

Hamlyn, K., et al., Tethered Orbital Refueling Study, Martin Marietta, NASA contract NAS 9-17059, Interim Report, January 1985.

Kroll, K.R., "Tethered Propellant Resupply Technique for Space Stations," IAF-84-442, presented at the 35th IAF Congress, Lausanne Switzerland, 1984.

Lorenzini, E., Analytical Investigation of Dynamics of Tethered Constellations in Earth Orbit, Aug. 17, 1984, NASA contract NAS 8-35497, SAO.

Mayer, H.L., "Swarms: Optimum Aggregations of Spacecraft," Aerospace Corporation ATR-80(7734)-1, Feb. 29, 1980.

Nobles, W., Selected Tether Applications in Space, July 31, 1984, Martin Marietta final report/presentation on NASA Contract NAS 8-35499.

Penzo, P., Tether Induced Gravity for Space Station—Preliminary Assessment, JPL, March 12, 1982.

TRANSPORTATION

—, Preliminary Feasibility Study of the External Tank (ET) Deorbit by a Tether System, May 24, 1983, Martin Marietta Memo 83-SES-665.

—, Tether Applications for the Inertial Upper Stage, Jan 1985, available from G. Ryan, IUS Futures Organization, Boeing Aerospace Company.

Arnold, D.A., Orbital Pumping, NASA Contract NAS 8-35036, Aug. 24, 1984, SAO.

Bentz, D.J. Tethered Momentum Launching Systems, NASA Lewis Research Center.

Carroll, J.A., Tethers and External Tanks: Enhancing the Capabilities of the Space Transportation System, final report to Martin Marietta Corp. on contract RH2-393673, Dec 1982.

Carroll, J.A., Tethers & External Tanks, ch. 3 of Report on the Utilization of the External Tanks of the STS, CSI, April 1983.

Carroll, J.A., and A.H. Cutler, "Potential Role of Tethers in Space Transportation", AIAA-84-1448, presented at AIAA/SAE/ASME 20th Joint Propulsion Conference, Cincinnati OH, June 1984.

Carroll, J.A., Tether Applications in Space Transportation, IAF Paper 84-438, 35th IAF Congress, Lausanne, Switzerland, 1984. To be published in ACTA ASTRONAUTICA.

Carroll, J.A., Disposable-Tether Payload Deploying System for the STS, final report on NASA SBIR Contract NAS 8-35843, Energy Science Labs., Inc., June 1984.

Contella, M.C., Tethered Deorbit of the External Tank, April 24, 1984, NASA JSC.

Colombo, G., Study of Certain Launching Techniques Using Long Orbiting Tethers, NASA-CR-164060, March 1981, SAO.

Colombo, G., et al., "Use of Tethers for Payload Orbital Transfer," report on NAS8-33691, Mar 1982, SAO.

Colombo, G., Orbital Transfer and Release of Tethered Payloads, report on NASA Contract NAS 8-33691, March 1983, SAO.

Hunter, M.W., "Near Earth Transportation Options and High Payoff Choices", AIAA International Annual Meeting, Baltimore, MD, May 1982.

Hunter, M.W., "Advanced Space Transportation Options", Lockheed, August 1982.

Martinez-Sanchez, M., The Use of Large Tethers for Payload Orbital Transfer, MIT, 1983.

Martinez-Sanchez, M., and S.A. Gavit, "Four Classes of Transportation Applications Using Space Tethers—Preliminary Concept Assessments", progress report to Martin Marietta, MIT Space Systems Laboratory, March 1984.

Stuart, D.G. and Martinez-Sanchez, M., Shuttle Tether Use for Payload Deployment to Circular Orbits, MIT, Aug. 10, 1984.

Penzo, P.A. and Mayer H.L., Tethers and Asteroids for Artificial Gravity Assist in the Solar System, JPL, AIAA Paper 84-2056, Aug. 1984.

Tschirgi, J., Tether Deployed SSUS-A, McDonnell Douglas, April 1984, NASA Contract NAS 8-32842.

ELECTRODYNAMICS

—, "Report of the Plasma Physics and Environmental Perturbation Laboratory Working Groups," Program Development Contract, NASA TM X-64856, March 1974.

Alfven, H., "Spacecraft Propulsion; New Methods", Science, Vol. 176, 14 April 1972, pp. 167-168.

Anderson, J., D. Arnold, G. Colombo, M. Grossi, & L. Kirshner, Orbiting Tether's Electrodynamic Interactions, final report on NAS5-25077, April 1979, SAO.

Arnold, D., and M. Dobrowolny, Transmission Line Model of the Interactions of a Long Metal Wire with the Ionosphere, submitted to Radio Science, 1979.

Arnold, D.A., and M.D. Grossi, Natural Damping in the Electrodynamic Tether, January 1983, SAO.

Banks, P.M., P.R. Williamson, and K.L. Oyama, "Shuttle Orbiter Tethered Subsatellite for Exploring and Tapping Space Plasmas," *Aeronautics and Astronautics*, February 1981.

Chu, C., and R. Gross, *Alfven Waves and Induction Drag on Long Cylindrical Satellites*, *AIAA Journal*, Vol 4, pg 2209, 1966.

Colombo, G., M. Grossi, M. Dobrowolny, and D. Arnold, *Investigation of Electrodynamic Stabilization & Control of Long Orbiting Tethers*, Interim Report on Contract NAS8-33691, March 1981, SAO. (Also, monthly progress reports #1-15 through September 1982.)

Dobrowolny, M., G. Colombo and M.D. Grossi, "Electrodynamics of Long Conducting Tethers in the Near Earth Environment," Interim Report on NASA Contract #NAS 8-31678. Jan 5, 1976, SAO.

Dobrowolny, M., G. Colombo, and M.D. Grossi, "Electrodynamics of Long Tethers in the Near-Earth Environment," Final report on NAS 8-31678, June 1976, SAO.

Dobrowolny, M., D.A. Arnold, G. Colombo, and M. Grossi, "Mechanisms of Electrodynamic Interactions with a Tethered Satellite System and the Ionosphere", *Reports in Radio and Geoastronomy*, No. 6, August 1979.

Dobrowolny, M., *Wave and Particle Phenomena Induced by an Electrodynamic Tether*, SAO Special Report #388, November 1979.

Drell, S.D., H.M. Foley, & M.A. Ruderman, "Drag and Propulsion of Large Satellites in the Ionosphere: An Alfven Propulsion Engine in Space," *J. of Geophys. Res.*, Vol. 70, No. 13, pp. 3131-3145, July 1965.

Finnegan, P.M. *A Preliminary Look at Using a Tethered Wire to Produce Power on a Space Station*, NASA LeRC, May 10, 1983.

Giudici, R., *Electrodynamic Tether for Power or Propulsion Design Considerations*, March 20, 1984, NASA MSFC-PD.

Grossi, M., "A ULF Dipole Antenna on a Spaceborne Platform of the PPEPL Class", Report on NASA Contract NAS8-28203, May 1973, SAO.

Grossi M., *On The Feasibility of Electric Power Generation and Electromagnetic Wave Injection by Electrodynamic Tethers*, Jan 1983, Tech. Note TP 83-003, SAO.

Grossi, M., *Engineering Study of the Electrodynamic Tether as a Spaceborne Generator of Electric Power*, April 1984. NASA Contract NAS 8-35497, SAO.

King, R.W.P., *The Thin Wire Antenna Embedded in a Magneto-ionic Plasma*, 1980, Harvard University.

McCoy, J.C. *Electrodynamic Tether Applications—Massive Tether Dynamics Study*, General Status Review, May 3, 1984, NASA JSC-SN 3.

McCoy, J.C. *Plasma Motor/Generator—Electrodynamic Tether Applications in Space*, NASA JSC-SN 3, June 13, 1984.

McCoy, J.C. *Plasma Motor/Generator—Proof of Function Experiment*, NASA JSC-SN 3, July 1, 1984.

Moore, R.D., "The Geomagnetic Thruster—A High Performance "Alfven Wave" Propulsion System Utilizing Plasma Contacts," AIAA Paper No. 66-257.

Tang, W.Y., "Comparison of Three Kinds of Possible Power Generators as Space Shuttle Power Extension Package," Dec 31, 1981, SAO.

Thompson, W.B., Electrodynamics of a Conducting Tether, Final Report to Martin Marietta on task 4 of contract RH 3-393855, Dec. 1983, CSI & UCSD Physics Dept.

Weiffenbach, G.C., "A Study of the Electrodynamics of Long Conducting Tethers in the Near Earth Environment", NAS8-31678, SAO.

Williamson, D.P., and Banks, P.M., The Tethered Balloon Current Generator: A Space Shuttle-Tethered Subsatellite for Plasma Studies and Power Generation, final report on NOAA Contract #03-5-022-60, Jan. 16, 1976.

Williamson, P.R., P.M. Banks, and K. Oyama, "The Electrodynamic Tether," report on NASA Contract NAS5-23837, 1978, Utah State University, Logan UT.

TETHER DYNAMICS, CONTROLS AND SIMULATIONS (incl. TSS)

—, Symposium on Passive Gravity Gradient Stabilization, NASA SP-107, May 1965.

—, Evaluation of Tether Dynamics and Control System Interaction, Final Report, NASA Contract NAS 8-34667, June 30, 1983.

Arnold, D., "General Equations of Motion," Appendix A of Investigation of Electrodynamic Stabilization and Control of Long Orbiting Tethers, Interim Report, March 1981, SAO.

Allias, E. and S. Bergamaschi, "Dynamics of Tethered Satellites—Two Alternative Concepts for Retrieval", MECCANICA. June 1979, p. 103-111.

Anderson, W.W., On Lateral Cable Oscillations of Cable-Connected Space Stations, NASA TN 5107, NASA Langley Research Center.

Bainum, P.M. and V.K. Kumar, "Optimal Control of the Shuttle-Tethered System", ACTA ASTRONAUTICA, Vol. 7, May 80, p. 1333-1348. Presented as IAF#79-190 at the 30th IAF Congress, Munich, Germany. Sept. 1979.

Bainum, P.M., R.E. Harkness and W. Stuiver, "Attitude Stability and Damping of a Tethered orbiting Interferometer Satellite System", Journal of Astronautical Sciences, Vol. XIX, No. 5, p. 364-389, Mar-Apr. 1972.

Banerjee, A.K. and T. R. Kane, "Tethered Satellite Retrieval with Thruster Augmented Control", AIAA/AAS Astrodynamics Conference, San Diego Calif, 1982. #AIAA 82-1-21.

Banerjee, A.K. and T.R. Kane, "Tether Deployment Dynamics", Journal of Astronautical Sciences, Vol. XXX, No. 4, pp. 347-365, Oct-Dec 1982.

Beletskii, V.V. and M. Guivertz, "The Motion of an Oscillating Rod Subjected to a Gravitational Field", Kosmicheskie Issledovania 5, no. 6, 1967.

- Beletskii, V.V., *The Motion of Celestial Bodies*, Nauka, Moscow, 1971.
- Beletskii, V.V., "Resonance Phenomena at Rotations of Artificial and Natural Celestial Bodies," *COSPAR-IAU-IUTAM Satellite Dynamics Symposium*, June 1974, Sao Paulo, Brazil; Springer-Verlag, 1975.
- Beletskii, V.V. and E.M. Levin, "Mechanics of an Orbital Cable System", translated from *Kosmicheskie Issledovaniya*, Vol 18 #5, pp. 678-688, Sept-Oct, 1980.
- Bergamaschi, Silvio, "Tether Motion after Failure", *Journal of Astronautical Sciences*, Vol. XXX, No. 1, pp. 49-59, Jan-Mar 1982.
- Buckens, F., "On the Motion Stability of Tethered Satellites Configuration", *Proceedings of the 12th International Symposium on Space Technology and Science*, H. Nagasu, ed., AGNE Publishing, Inc., 1977, Tokyo, pp. 351-358.
- Chobotov, V., "Gravity-gradient Excitation of a Rotating Cable-Counterweight Space Station in Orbit", *Journal of Applied Mechanics*, Vol. 30, P. 547-554.
- Colombo, G., *The Stabilization of an Artificial Satellite at the Inferior Conjunction Point of the Earth-Moon System*, SAO Special Report #8, 1961.
- Colombo, G., "Study of Tethered Satellite Active Attitude Control", NASA Contract NAS 8-33691, Interim Report, Oct 1982, SAO.
- Colombo, G., *Tether Dynamics Software Review; High Resolution Tether Dynamics; and Advanced Tether Applications (Damping through Reel Motor Control; Payload Acquisition by Space Station)*, Jan. 1984, NASA Contract NAS 8-35036, SAO.
- Diarra, C.M., "The Effects of Tether Mass on the Stability and the Controllability of the Shuttle-Tethered Subsatellite System", IAF#82-06, 33rd IAF Congress, Paris, France, Sept 1982.
- Eads, J.B. and Wolf, H., *Tethered Body Problems and Relative Motion Orbit Determination*, NAS-5-21453, Analytical Mechanics Association, Inc., Aug. 1972.
- Farquhar, R., *The Control and Use of Libration Point Satellites*, NASA TR R-346, Washington DC, 1970.
- Farquhar, R., *The Utilization of Halo Orbits in Advanced Lunar Operations*, NASA TN D-6365, Washington DC, 1970.
- Garber, T.B., "A Preliminary Investigation of the Motion of a Long, Flexible Wire in Orbit", Rand Report-RM-2705-ARPA, March 23, 1961.
- Glaese, J.R. and H.L. Pastrick, "Modal Synthesis Simulation of the Shuttle Orbiter Tethered Satellite System", AIAA/AAS Astrodynamics Conference, San Diego, AIAA-82-1424, 1982.
- Hagedorn, P., & S. Otterbein, "Some Remarks on the Control of Variable Length Tethered Satellites with Attitude-Orbit Coupling", Institut Fur Mechanik, T.H. Darmstadt, Darmstadt, Federal Republic of Germany.
- Kalaghan, P.M., et al., *Study of the Dynamics of a Tethered Satellite System (Skyhook)*, "Final Report on Contract NAS8-32199, March 1978, SAO.
- Kane, T.R., "A New Method for the Retrieval of the Shuttle-Based Tethered Satellite," *J. of the Astronaut. Sci.*, Vol 32, No. 3, July-Sept. 1984.
- Kirschner, L.R., "The Skyhook Program: A Software Package for a Tethered Satellite System, Including Electrodynamics Interactions", NASA Technical Report Contract NAS 8-33691. May 1980.

Kohler, P., W. Maag, R. Wehrli, R. Weber, & H. Brauchi, "Dynamics of a System of Two Satellites Connected by a Deployable and Extensible Tether of Finite Mass", ESTEC Contract #2992/76/NL/AK(SC), Vol 1 and 2. 1978.

Kulla, P., "Stabilization of Tethered Satellites", ESTEC Report TMM/78-07/PK/AVS, 1977.

Kulla, P., "Dynamics of Tethered Satellites", Proceedings of the Symposium on Dynamics and Control of Non-Rigid Spacecraft, Frascati, Italy, 1976.

Lang, D.D., Tethered Object Simulation System (TOSS) Reference Manual, NASA Contract NAS9-16715, Sept 1983.

Lips, K.W. and V.J. Modi, "General Dynamics of a Large Class of Flexible Satellite Systems", ACTA ASTRONAUTICA, Vol. 7, 1980, pp. 1349-1360.

Misra, A.K. and Modi, V.J., "A General Dynamical Model for the Space Shuttle Based Tethered Subsatellite System", Advances in the Astronautical Sciences, 40, 537-557, 1979.

Misra, A.K. and J.J. Modi, "Dynamics and Control of Tether Connected Two-Body Systems - A Brief Review", 33rd IAF Congress, Paris, France, Sept-Oct 1982.

Misra, A.K. and V.J. Modi, "Deployment and Retrieval of a Subsatellite Connected by a Tether to the Space Shuttle", paper AIAA-80-1693 presented at the AIAA/AAS Astrodynamics Conf., Danvers, Mass.

Modi, V.J. and A.K. Misra, "Deployment Dynamics and Control of Tethered Satellite Systems", AIAA/AAS#78-1398, AIAA/AAS Astrodynamics Conference, Palo Alto, Calif, Aug 1978.

Modi, V.J., G. Chang-fu, and A.K. Misra, "Effects of Damping on the Control Dynamics of the Space Shuttle Based Tether System", AAS/AIAA Astrodynamics Conference, Lake Tahoe, AAS-81-143.

Modi, V.J., G. Chang-fu, A.K. Misra and D.J. Xu, "On the Control of the Space Shuttle Based Tether System", Acta Astronautica, Vol 9 No.6-7, 1982.

Pengelly, C.D., "Preliminary Survey of Dynamic Stability of a Cable-Connected Spinning Space Station", Journal of Spacecraft, Oct 1966.

Perrine, B.S., "A Method for Soft Tethered Station Keeping", NASA TMX-53643, Marshall Space Flight Center, July 31, 1967.

Pringle R., "Exploration of Nonlinear Resonance in Damping an Elastic Dumb-Bell Satellite", AIAA Journal, 1968, N. 7, 1217-1222.

Raabe, H.P., "Self-Stabilizing Satellite," US Patent 3,206,142. Sept 14, 1965.

Rheinfurth, M.H. et al., Modal Analysis of a Non Uniform String with End Mass and Variable Tension, NASA-TP-2198, Aug. 1983.

Rupp, C.C., A Tether Tension Control Law for Tether Subsatellites Deployed Along Local Vertical, NASA TM X-64963, MSFC, September 1, 1975.

Rupp, C.C. and L.L. Gresham, "A Preliminary Study of the Attitude Control for the Shuttle Tether Satellite System", IEEE Journal, 1979.

Sarychev, V.A., "On the Dynamics of Tether-Connected Two-Body Systems", IAF-82-316, 33rd IAF Congress, Sept 27-Oct 2, 1982, Paris, France.

Singh, R.B., "Three Dimensional Motion of a System of Two Cable-Connected Satellites in orbit", *ASTRONAUTICA ACTA*, Vol. 18, 1973, pp. 301-308.

Spencer, T.M., "Atmospheric Perturbation and Control of a Shuttle/Tether Satellite", *Automatic Control in Space, Proceedings of the 8th Symposium*, Oxford, England July 2-6, 1979. p. 101-108.

Stuiver, W., "Lagrange Configurations in Space System Dynamics", *Journal of the Astronautical Sciences*, 25(1977), p. 91-106.

Stuiver, W., and P.M. Bainum, "A Study of Planar Deployment Control and Libration Damping of a Tethered Orbiting Interferometer Satellite", *Journal of Astronautical Sciences*, Vol. 20, No. 6, pp. 321-346, May-June 1973.

Swan, P.A., "Dynamics & Control of Tethers in Elliptical Orbits," IAF-84-361, presented at the 35th IAF Congress, Lausanne, Switzerland, October 1984.

Swet, C.J. & J.M. Whisnant, "Deployment of a Tethered Orbiting Interferometer", *Journal of Astronautical Sciences*, Vol 17, No. 1, pp. 44-59, Jul-Aug 1969.

Swet, C.J., "Method for Deploying and Stabilizing Orbiting Structures," US Patent 3,532,298, Oct 6, 1970.

Synge, J.L., "On the Behaviour, According to Newtonian Theory, of a Plumb Line or Pendulum Attached to an Artificial Satellite", *Proceedings of the Royal Irish Academy*, Vol. 60, Sec A, 1-6, 1959.

Xu, D.M., A.K. Misra, and V.J. Modi, "Three Dimensional Control of the Shuttle Supported Tether Satellite Systems During Deployment and Retrieval", *Proceedings of the 3rd VPISU/AIAA Symposium on Dynamics and Control of Large Flexible Spacecraft*, Blacksburg, Va., 1981.

BEANSTALKS & OTHER AMBITIOUS TETHER CONCEPTS

Anderson, J., G. Colombo, L. Friedman, E. Lau, "An Arrow to the Sun", presented at International Symposium on Experimental Gravitation, Pavia, Italy, Sept 1976.

Artsutanov, Y., *V Kosmos na Electrovoze; Komsomolskaya Pravda*, July 31, 1960. (summarized in English in *Science*, Vol. 158, pp. 946-7.)

Birch, Paul, "Orbital Ring Systems and Jacob's Ladders-1", *Journal of the British Interplanetary Society*, Vol. 35, No. 11, Nov 82, p. 474-497.

Birch, Paul, "Orbital Ring Systems and Jacob's Ladders-2", *Journal of the British Interplanetary Society*, Vol. 36, No. 3, Dec 82, p. 115-128.

Clarke, A.C., *The Fountains of Paradise*, Ballantine Books, 1978. (Novel) Includes a postscript discussing the history of the "space elevator" concept.

- Clarke, A.C., *The Space Elevator: 'Thought Experiment' or Key to the Universe?* Address to the 30th IAF Congress, Munich, 20 Sept. 1979.
- Collar, A.R., and J.W. Flower, "A (relatively) Low Altitude 24 Hour Satellite", *Journal of the British Interplanetary Society*, Vol. 22, 442-457, 1969.
- Isaacs, J., H. Bradner, G. Backus, and A. Vine: *Satellite Elongation into a True "Skyhook"; a letter to Science*, Vol. 151, pp 682-683, Feb 11, 1966. See also the discussions in Vol. 152, pg. 800, and Vol. 158, pp. 946-947.
- Iwata, "Space Escalator, a quasi-Permanent Engine in Space", presented at the 30th IAF Congress, Munich, Sept 1979.
- MacConochie, I., et. al. *Capture-Ejector Satellite*, Oct. 1983, NASA-TM 85686, NASA Langley Research Center.
- Moravec, H. "A Non-Synchronous Orbital Skyhook," *J. of the Astronautical Sciences*, Vol. XXV, No. 4, pp. 307-322, Oct-Dec 1977.
- Niven, L., & S. Barnes: *The Descent of Anansi*, Pinnacle Books, 1982. (Novel)
- Pearson, J., "The Orbital Tower: a Spacecraft Launcher Using the Earth's Rotational Energy," *Acta Astronautica*, Vol.2, pp. 785-799, Pergamon, 1975.
- Pearson, J., "Using the Orbital Tower to Launch Earth-Escape Payloads Daily", AIAA Paper 76-123, 27th IAF Congress, 1976.
- Pearson, J., "Lunar Anchored Satellite Test", AIAA/AAS Astrodynamics Conference, Palo Alto, August 1978.
- Pearson, J., "Anchored Lunar Satellites for Cislunar Transportation and Communication," *J. of the Astronautical Sciences*, Vol. 27, No. 1, pp. 39-62, Jan-Mar 1979.
- Pearson, J., "Asteroid Retrieval by Rotary Rocket", AIAA Paper 80-0116, presented at the AIAA 18th Aerospace Sciences Meeting, Pasadena CA, Jan 1980.
- Penzo, P.A. and H.L. Mayer, "Tethers and Asteroids for Artificial Gravity Assist in the Solar System", AIAA/AAS Astrodynamics Conference, Seattle WA, Aug 20-22, 1984.
- Penzo, P.A., "Tethers for Mars Space Operations", The Case for Mars II, Univ. of Colorado, Boulder CO July 10-14, 1984.
- Polyakov, A Space 'Necklace' about the Earth, (*Kosmicheskoye ozherel'ye zemli*), *Teknika Molodezhi*, No. 4, 41-43 (1977). (NASA TM-75174)
- Sheffield, C., *The Web Between the Worlds*, Ace Science Fiction, 1978. (Novel)
- Simberg, R.E., "The Geosynchronous Tidal Web, A Method for Constructing an Ultra-Large Space Structure", *Space Manufacturing 4*, Proceedings of the 5th Princeton/AIAA Conference, May 18-21, 1981, published by AIAA.
- Tsiolkovsky, K.E., *Grezy O. Zemie i nebe (i) Na Veste (Speculations between earth & sky, & on Vesta; science fiction works)*. Moscow, izd-vo AN SSSR, 1959.

TETHER MATERIALS

G. Graff, "Superstrong Plastics Challenge Metals", High Technology magazine, February 1985, pp. 62-63.

Holler, R. A., Metallized Kevlar for Undersea Electromechanical Cables, Naval Air Development Center, Warminster, PA., Sept. 1984.

Ross, J.H., "Superstrength-Fiber Applications," Astronautics & Aeronautics, December, 1977.

The following reports are available from Du Pont's Textile Fibers Department:

Kevlar 49 Aramid for Pultrusion. 1975.

Characteristics and Uses of Kevlar 29 Aramid. 1976.

Characteristics and Uses of Kevlar 49 Aramid High Modulus Organic Fiber. 1978.

The Effect of Ultraviolet Light on Products Based on Fibers of Kevlar 29 and Kevlar 49 Aramid. 1977. Information only on terrestrial applications.