

NASA Technical Memorandum 890/13

**DESIGN, CONSTRUCTION AND UTILIZATION OF A SPACE STATION
ASSEMBLED FROM 5-METER ERECTABLE STRUTS**

MARTIN M. MIKULAS, JR. AND HAROLD G. BUSH

(NASA-TM-89043) DESIGN, CONSTRUCTION AND
UTILIZATION OF A SPACE STATION ASSEMBLED
FROM 5-METER ERECTABLE STRUTS (NASA) 40 p
CSCL 22B

N87-11827

Unclass
G3/18 44866

OCTOBER 1986



National Aeronautics and
Space Administration

Langley Research Center
Hampton, Virginia 23665

DESIGN, CONSTRUCTION AND UTILIZATION OF A SPACE STATION
ASSEMBLED FROM 5-METER ERECTABLE STRUTS

Martin M. Mikulas, Jr. and Harold G. Bush
Langley Research Center
Hampton, Virginia

INTRODUCTION

The truss structure is a key element in enabling the Space Station to be a highly versatile facility capable of essentially unlimited evolutionary growth and use. Construction of the Space Station is planned in the 1990's and it is expected to provide a space operation base for the next 20 years or more. Due to this long life it is important that the truss structure be capable of evolutionary growth in all three dimensions, and be capable of easily accommodating unanticipated alterations. It should be capable of accommodating a wide variety of shuttle-compatible payloads in a customer friendly fashion with a minimum of interference to growth and station operations. The truss must also provide a stiff and stable framework to: (1) minimize structure-control interaction, (2) simplify the pointing systems of stellar, solar, and earth observation instruments, and (3) accommodate micro-g experiments. Several truss structures which have been considered for the Space Station are described in ref. 1. A trade study which dealt in depth with the merits of the various trusses is presented in ref. 2. In ref. 2, it was concluded that the most desirable truss for Space Station should be as deep as possible for maximum bending stiffness and for minimum weight and part count. However, the truss should also be sized to be compatible with Space Shuttle cargo bay size payloads. With these considerations in mind, a 5-meter-deep, square cross-section truss has been baselined for the Space Station support structure. Another feature of the 5-meter erectable truss is that it is constructed in a cubic arrangement using three-dimensional nodal clusters that permit architectural evolution for construction and growth in three orthogonal directions.

A major consideration in the design of the Space Station is on-orbit construction. In ref. 2 a trade study was conducted of deployable and erectable trusses for Space Station. The study showed that deployable trusses, though attractive for space trusses because of the reduced EVA required for initial construction, are limited in size due to launch volume constraints. Erectable trusses offer the freedom to configure and size the truss size to operational needs. Thus the decision is to choose between reduced EVA construction hours for initial assembly of the deployable truss, or the additional bending stiffness and architectural freedom offered by the larger erectable truss. In January 1986, the 5-meter erectable truss was selected as a baseline for the Space Station. This paper summarizes the primary operational characteristics and structural details of the current baseline truss.

DUAL KEEL STATION

The current baseline 5-meter truss, dual keel Space Station is shown in fig. 1 and schematic details are shown in fig. 2. As shown in the side view, the two

vertical keels fly in a gravity gradient earth pointing mode. The outboard solar power systems rotate relative to the central portion of the station to continuously point to the sun. The two long vertical keels (110 m.) are to provide space for mounting the numerous payloads to be attached to the station. The pressurized living modules are placed at the center of gravity of the Space Station to minimize artificial gravity effects. Stellar pointing payloads are placed on the upper transverse boom, while earth pointing payloads are placed on the lower transverse boom. The solar power systems are widely spaced to reduce plume impingement problems and contamination from the Space Shuttle during docking. The 5-meter truss provides a stiff support for the pressurized modules, the solar power systems, and numerous stellar and earth-pointing payloads. The Space Station will have several independent pointing control systems; thus the truss should be stiff to avoid excessive interaction among these control systems. Since the station is too large to be assembled and tested on the ground, it is necessary that the structural response be linear and predictable for control purposes.

TRUSS REQUIREMENTS

There is no precedent for an on-orbit structure as large and complex as that being considered for the Space Station. The truss structure must provide a stiff, redundant framework to support massive pressurized modules, a large solar power system, and numerous scientific payloads, many of which require accurate pointing systems. It must be designed to permit the integral attachment of large protective hangars and to provide a location for the construction of other large spacecraft. The primary requirements which drive the truss design are:

- o Stiffness, Mass, and Cost
- o Customer Accommodations
Payloads, Growth, Spacecraft Construction
- o Space Station Operations
Payload Movement, Maintenance, Servicing
- o Space Station Construction
EVA Time, Reliability and Safety, Construction Experience

In the present paper these four requirements will be discussed and it will be shown how they entered into the selection of the 5-meter erectable truss for the Space Station.

STIFFNESS, MASS, AND COST

In this section the stiffness, mass, and cost of truss structures are compared as a function of the depth of the truss. In all cases the truss bays are assumed to be cubic and only the size is varied. Since the Space Station truss is stiffness designed, the struts are assumed to be constructed of high modulus graphite/epoxy.

The struts are assumed to be clad inside and out with aluminum to protect against erosion due to atomic oxygen, eliminate out-gassing, and provide a mechanism to tailor the coefficient of thermal expansion of the strut. The nominal strut is assumed to have a wall laminate as follows:

Aluminum layer	.006"	(.152 mm)
P-70 Gr/Ep layer	.060"	(1.52 mm)
Aluminum layer	.006"	(.152 mm)
Total Wall Thickness	.072"	(1.83 mm)
Average Density =	.068 lb/in ³	(1880 Kg/m ³)
Average Modulus ~	40 x 10 ⁶ psi	(276 GPa)

The relative thickness of aluminum and graphite/epoxy was chosen to achieve a nominal zero coefficient of thermal expansion in the strut.

The operational loads experienced by the Space Station are very low due to the zero-g environment. The largest loads are a result of docking with the Space Shuttle. Attenuators are being designed for the docking maneuver so that even those loads will be small. Thus, the primary structural requirement for the truss is that of high stiffness to minimize structure-control interaction and to minimize the magnitude and duration of transient responses.

Part Count. The effect of truss size on part count is shown in fig. 3. As shown in the top two sketches, the total length of strut material required to construct a beam is independent of the depth of the beam. Further, the number of parts in such beams is inversely proportional to the beam depth. The lower sketches show that the number of parts for a two-dimensional area type truss is inversely proportional to the square of the depth. For area trusses, the length of struts per unit of area covered increases linearly as the strut length decreases. Because of these size characteristics, longer length truss struts result in lower total weight and cost. There are practical limits, however, to the maximum length of the individual struts for different applications. In the case of the Space Station, the upper limit to the strut length was selected to make the truss compatible with payloads having the diameter of the Space Shuttle cargo bay. The maximum payload diameter for the cargo bay is 14.5 ft. The truss strut length was chosen to be 5-meters (16.4 ft.) to permit a clearance between the truss and payload for operations.

Truss Mass and Stiffness. The mass and part count for the current dual keel space station 5-meter erectable truss is shown in fig. 4-a as a function of beam depth. These results show that for struts of constant wall thickness, a 3-meter deep beam would be 20 percent heavier than a 5-meter deep beam. If the bending stiffness of the beam were constrained to be equal to the 5-meter truss, the weight of the smaller depth beams increases dramatically. It is shown in the figure that a 3-meter deep beam of equal bending stiffness would weigh twice as much as a 5-meter deep beam. Due to the added launch cost for the extra weight and the higher costs for the material, the smaller depth beam is considerably more expensive to put in orbit. Another factor that affects this trade is assembly time which is almost directly proportional to the number of parts to be handled. Again, the deeper truss shows an advantage (e.g., reduced assembly time).

The importance of stiffness of the Space Station truss was studied in ref. 4. In ref. 4, a detailed finite element analysis of the station indicated that the framework frequencies of the 5-meter configuration were almost double those of the 9-ft. bay configuration. This increase results in reduced dynamic response as shown by an example of results from ref. 4, in fig. 4-b. This figure shows

a continuous trace of the flexible sunline at the outer solar dynamic collector during a reboost maneuver. The maximum allowable angular excursion for the solar dynamic system is 0.1 degree. The angular excursions for the 9-foot truss are three times as great as the 5-meter truss and as can be seen in the figure, there is very little margin for the 9-foot truss system. These results are typical of other examples studied in ref. 4 and demonstrate the importance of the increased stiffness offered by the 5-meter strut construction.

OTV Hangar Construction. The OTV hangar is representative of a number of protective hangars that are anticipated on the Space Station. Construction of the support truss for the hangar is also typical of the construction that will be required for other large space systems to be built on the Space Station. In fig. 5 a comparison is given for constructing a hangar from 9-ft. struts and 5-meter (16.4 ft.) struts. As can be seen in the figure, a 9-ft. strut hangar requires three times as many struts and nodes as a 5-meter strut hangar. The weight of the 9-ft. strut hangar is twice the weight of a 5-meter strut hangar and the construction time is about three times as long. These differences are significant and are an indication of the long term benefits that will result from the 5-meter strut construction approach.

CUSTOMER ACCOMMODATIONS

The Space Station is planned to be placed in orbit in the early 1990s and is expected to provide a space operations base for the next 20 years or more. It is highly likely that the functional use of this space base will continually evolve as operational experience accumulates. For this reason it is important that the truss structure, which forms the backbone of the station, be capable of evolutionary change and growth in all three dimensions and must readily accommodate unanticipated changes. The truss structure must accommodate a wide range of shuttle-compatible payloads with minimum interference to growth and station operations.

Growth Potential. To provide a truss with growth capability in all three dimensions, it is necessary that the nodal cluster at the intersection of the struts be designed so that struts in all dimensions can be added as needed. Such a node is shown schematically in fig. 6 for an orthogonal truss. To permit complete three-dimensional growth of such a truss, it is necessary that each node possess 18 strut attachment positions. There are 6 strut attachment positions in the x, y, and z directions, and 12 strut attachment positions at 45 degrees to the coordinate axes for the diagonals. For the current baseline node, 8 additional strut attachment positions are provided for attachment of payloads. These 8 positions are shown as triangles on the node in fig. 6. The direction of these positions coincides with a diagonal line which passes through the center of the cube. A photograph of such a node is shown in fig. 7 with two quick attachment erectable joints. Such spherical nodes have been used for many years in the construction of ground structures and there is a large body of knowledge relative to their use. The main difference in the current node is the use of quick attachment joints to minimize the EVA effort required to assemble the structure. For applications in space, the node would be shipped to orbit with the necessary number of quick attachment joints bolted in place to construct the initial structure. Extra joints could be attached initially or could be bolted on in orbit if needed for growth.

Payload Accommodations. The most common types of payloads to be accommodated by the station are either small instruments or experiments, or large cargo-bay-sized payloads. It is likely that even the smaller payloads will be integrated onto a standardized pallet in the shuttle/station mission system. For launch efficiencies, this pallet would likely be sized to make maximum use of the cargo bay volume (pallet size is approximately 14.5 ft. in diameter). Most larger payloads (storage tanks, large instruments, spacecraft, etc.) will also be sized to maximize use of the cargo bay. The 5-meter truss has been sized specifically to be compatible with cargo-bay-sized payloads. The payloads can be attached to the interior or exterior of the truss with no interference to adjacent bays. This feature is important to minimize congestion on the station and to ensure that attached payloads do not interfere with operations such as payload movement and additional construction.

A schematic showing the growth capability of the 5-meter truss is shown in fig. 8. As can be seen in the schematic, the payloads are attached to the cubic diagonal attachment positions. Such an attachment scheme does not interfere with structural attachment positions so that the truss can be constructed over previously attached payloads for growth if desired. It is also shown that cargo-bay-sized payloads fit nicely within each truss bay and do not interfere with operation of the mobile remote manipulator system (MRMS).

The growth shown in fig. 8 could occur in a gradual, evolutionary fashion using the erectable method of construction. Because of the high redundancy of the truss, many selected struts may be omitted to enhance accessibility or to accommodate payloads longer than one bay.

A sketch of an octagonal cargo bay sized pallet is shown attached to the 5-meter structure in fig. 9. Attachment arms which would fold to fit in the cargo bay are shown in the inset. A payload attachment fixture is shown attached to the truss node in a cubic diagonal position, and the pallet arm with a simple protrusion connector is shown in position prior to insertion and lock up. Since the four longeron truss is redundant, the face diagonal can be removed for payload insertion without destroying the integrity of the truss. In a multiple bay keel or in an area where there are many bays, the high redundancy of the truss would permit the diagonal to be permanently omitted if desired. Such a subsurface attachment of the pallet permits complete unobstructed movement and operation of the MRMS over the truss surface yet still provides access for servicing.

For some payloads it may be necessary to provide protection from propulsion plumes, radiation, micrometeoroids, or to provide thermal control. A concept for providing such shielding is shown in fig. 10. In this concept, deployable "curtains" would be added as needed to provide the protection necessary. A hatch would be provided for access and, as can be seen in the figure, the 5-meter truss provides a large interior volume for servicing. An alternate, more highly preintegrated system is shown in fig. 11. In this concept, an octagonal pallet similar to that shown in fig. 9 would have a collapsible protective covering attached which would be deployed on-orbit. A hatch is shown on top of the shield for access. Such a system could provide protection from plume contamination by the shuttle during docking maneuvers and the hatch could be left open during other times. The high versatility for attaching payloads is shown in fig. 12. The upper left hand sketch demonstrates how a cargo bay size storage tank longer than one truss bay may be accommodated. The

other sketches demonstrate the capability of the 5-meter truss for accommodating a variety of space shuttle type payloads.

SPACE STATION OPERATIONS

The construction, operation, and maintenance of the Space Station will require numerous on-orbit operations of unprecedented complexity and duration. The truss, being the basic support structure for the station, must be designed to facilitate these operations in a reliable, safe fashion. The truss must support the pressurized modules, the subsystems, and all utility lines. Since these are widely dispersed on the station, there must be some means to transport materials and to support EVA or robotic operations.

Transport Systems. A mobile transport system designed to support space station operations is presented in refs. 4 and 5. A sketch of this system called the mobile remote manipulator system (MRMS) is shown in fig. 13. The transporter is attached to guide pins which are provided at each node of the truss. Mobility is provided by a push-pull draw bar which can move the mobile transporter one bay at a time. The transporter can turn 90 degrees and move in orthogonal directions. The transporter can also change planes to accomplish movement in all three dimensions. Thus, the combination of the cubic truss and MRMS represents a versatile system in which construction and operations can be accomplished in all three dimensions. Two mobile foot restraints are provided on the MRMS to provide astronauts, and possibly robots, with a positioning device to assist in construction and maintenance operations. A remote manipulator system (RMS) similar to the shuttle RMS is also provided to assist in material movement and positioning.

An alternate technique for maintenance and servicing is to provide a smaller mobile transporter inside the truss. This transporter could either be on rails or operate on internal guide pins in a fashion similar to the MRMS. A schematic of such a transporter is shown in fig. 14. In this figure the transporter is shown operating on rails and a robot is attached for servicing. The same concept could be used to provide mobility and support for an astronaut.

A simple system for transporting an astronaut about the station which is under consideration is a monorail, two truss bays long, which operates on the MRMS guide pins. A battery driven endless belt or chain would provide the mobility for the system. The astronaut would be attached to a controllable foot restraint which would provide a stable work platform to facilitate maintenance or servicing. A similar system could also be used for robotic operations.

Spacecraft Construction. One anticipated use of the Space Station is to serve as a base for constructing other spacecraft. The 5-meter erectable truss and the MRMS represent a versatile system for conducting a wide variety of construction scenarios. The truss can be grown to provide the necessary area for construction and the MRMS can provide the capability to move materials and support construction operations.

Crew Safety and ACCESS. The 5-meter erectable truss has been designed specifically to accommodate manual assembly by astronauts. The diameter of the quick attachment end joints as shown in fig. 15 was limited to 2 inches to be compatible with a pressured glove. The joints and struts were kept smooth and

snag free for safety reasons. As can be seen in fig. 16, the whole truss system (struts and joints) has been kept as hazard free as possible to facilitate safe astronaut operations.

A major consideration in the design of the truss is to provide adequate access for a space suited astronaut. For comparison purposes, an astronaut is shown inside of two different size truss in fig. 17. The astronaut is shown outfitted with a Manned Maneuvering Unit (MMU). It is anticipated that the MMU will be used for some Space Station operations. As can be seen in the figure, mobility and access in a 9-foot truss would be quite limited while there is ample access in a 5-meter truss.

SPACE STATION CONSTRUCTION

Detailed studies have been conducted on various approaches for constructing the Space Station on-orbit. Both erectable and deployable trusses for Space station are discussed in ref. 1, and a detailed trade study of the different approaches is presented in ref. 2. As mentioned previously, the 5-meter truss is desirable for Space Station for high bending stiffness and size compatibility with space shuttle payloads. However, since it must be erected strut by strut on-orbit, the alternative of a smaller truss which could be folded like an accordion and deployed on orbit must be considered.

EVA Construction Hours. In ref. 2 the trade-offs between deployable and erectable approaches are discussed in detail. A significant issue involved in that trade study is the amount of EVA required to construct the station. Results presented in fig. 18 show that the initial station can be constructed in seven shuttle flights. As expected, the station with deployable structure takes less time to construct than the erectable version. However, due to the large number of subsystems that must be installed on-orbit in both cases, the difference between total construction time is small. In fact, the advantages gained from the 5-meter truss over the 20 year lifetime of the station outweigh the extra EVA hours required for initial assembly.

For the erectable structures, the construction times used in these studies were taken from neutral-buoyancy assembly tests conducted on a large truss beam with 18 ft. struts (ref. 6). The results were also validated by a shuttle flight experiment where 10 bays of an erectable structure were assembled on-orbit (ref. 7). These tests will be discussed later in this section. Since there is no experience with deployable structures in this size range, engineering estimates were made of the construction times.

Construction Experience. Prior to 1980, studies were conducted of techniques for erecting large structures on orbit. Timeline investigations were performed both analytically and by testing in a neutral buoyancy facility. The earliest neutral buoyancy tests involved pressure suited test subjects erecting a truss with 18 ft. long struts with no assembly aids. The test subjects reported that unassisted assembly was very difficult and tiring. An assembly aid was then designed to provide mobile foot restraints for the test subjects, and to provide an assembly line like assembly fixture for the truss. This device, called a mobile work station is shown in fig. 19. In fig. 19, two astronauts are shown in the mobile foot restraints constructing the truss. The foot restraints can position the astronauts at any point required to construct a single bay. After one bay is completed, an endless chain moves the truss on a

rail in an assembly line fashion so that the next bay can be constructed. These underwater construction studies indicated that such structures could be space erected at the rate of one strut every 38 seconds.

Flight Experiments. In November 1985, a 10-bay truss was erected on-orbit by two astronauts out of the space shuttle cargo bay (refs. 7 and 8). In this experiment called ACCESS, the two astronauts were in fixed foot restraints while the truss was on an assembly fixture that could be rotated and registered one bay at a time as the truss was erected (fig. 20). A photograph of the actual on-orbit assembly is shown in fig. 21. The results of these tests are given in fig. 22. In this test the 10-bay truss comprised of 96 struts was constructed in 25 minutes on-orbit. Although this truss is smaller than that being considered for Space Station, the test results clearly demonstrated the practicality and economy of erected trusses on-orbit. During the ACCESS flight test the astronauts detached the 10-bay-long truss from the shuttle to demonstrate truss manipulation on-orbit. The astronauts indicated that the open truss was relatively easy to maneuver on-orbit. After the manipulation demonstration, they readily reattached the truss to the assembly fixture, and disassembled and restowed the truss.

The ACCESS flight experiment provided valuable data in validating neutral buoyancy zero-g construction simulations. The flight test demonstrated that neutral buoyancy simulations are quite good for an ACCESS size truss. The need for a flight experiment to assist in the development of construction techniques for a 5-meter truss Space Station is currently being evaluated. A study of a large scale flight experiment was conducted and reported on in ref. 9. This study considered the construction and dynamic testing of a "T"-shaped truss 16-bays long with a 5-bay wide cross member, as shown in fig. 23. The length and geometry of the truss was chosen to achieve low bending and torsional frequencies for on-orbit dynamic testing. The results of this study indicated that one-half of the space shuttle cargo bay would be required to place such an experiment in orbit. The results also indicated that two 6-hour EVAs would be required to construct and test the structure. A sequence of the construction process for the first 6-hour EVA is shown in figs. 24, 25, and 26. During the second EVA which is not shown, the remaining 8 truss bays are constructed and utility lines are installed. These studies of the construction process for the flight experiment verified that construction of the Space Station from 5-meter erectable struts was indeed practical.

Such a flight experiment would provide an interim step towards the construction of large structural systems such as Space Station. In-orbit dynamic tests could be conducted to provide insight into the 0-gravity dynamic response predictability of such truss structures. Due to the large economic resources required to conduct such a test, however, it may be prudent to combine the test with early construction of a portion of the station.

An alternate flight experiment would be to construct a truss of about 5 bays on-orbit. Due to the highly reduced number of struts to be constructed, a less elaborate assembly aid could be used. For example, the shuttle RMS could provide the movable foot restraint for the construction process. Such a test would provide information about the handling characteristics of such long struts and details on joining techniques. The results again would be valuable in calibrating neutral buoyancy simulations.

Once constructed, such a truss could be left on-orbit to provide a test facility for future flight experiments. A schematic of such a test bed is shown in fig. 23. The experiments to be tested on the orbiting truss would be built on standard space shuttle pallets. The 5-meter truss is sized to handle such payloads so installation would be the same as that for attaching experiments to Space Station. All attachments would be of Space Station type so that the experiment would provide early information on station operations as well as providing an early test bed for scientific experiments.

CONCLUDING REMARKS

This paper presents primary characteristics of the 5-meter erectable truss structure which has been baselined for the Space Station. A primary design consideration for the Space Station is to provide adequate stiffness to minimize structure-control interaction during operation. This consideration tends to require the station truss to be as deep as possible to provide maximum beam bending stiffness with the least structural mass. However, the truss must also provide convenient attachment locations for space shuttle cargo bay size payloads (~14.5 ft. in diameter).

These two considerations led to the 5-meter truss design for the Space Station. The deep truss provides both high bending stiffness, and a lower number of struts and nodes. This reduced part count is directly reflected in lower costs and reduced construction time. The truss is compatible with shuttle cargo-bay-sized payloads and reduces congestion on the station since every payload can be contained within the dimensions of each truss bay. This is an important consideration in simplifying long term operations on the station. A truss node fitting was designed to permit the truss to grow in all three orthogonal directions. This feature permits versatile evolutionary architecture and, together with the quick-attachment erectable joint, provides a truss system which can be readily repaired or updated with unanticipated alternations.

A mobile remote manipulator system (MRMS) is provided on the station to assist in construction, maintenance, and spacecraft servicing and construction. The cubic truss is designed to permit orthogonal movement of the MRMS in all three dimensions. Guide pins are provided at each of the truss nodes for attachment and movement of the MRMS. Detailed construction studies of each phase of the Space Station construction have been conducted to ensure compatibility with shuttle EVA resources. Although EVA timelines were slightly longer than desirable for comfortable margins, studies are continuing to reduce the amount of EVA required.

REFERENCES

1. Mikulas, Martin M. Jr., et al. Space Station Truss Structures and Construction Considerations. NASA TM-86338. (1985).
2. Mikulas, Martin M. Jr., et al. Deployable/Erectable Trade Study for Space Station Truss Structures. NASA TM-87573. (1985).
3. Young, John W.; Lallman, Frederick J.; Cooper, Paul A.; and Giesy, Daniel P. Control/Structures Interaction Study of Two 300 KW Dual-Keel Space Station Concepts. NASA TM-87679. (1986).

4. Mikulas, Martin M. Jr.; Bush, Harold G.; Wallson, Richard E.; Dorsey, John T.; and Rhodes, Marvin D. A Manned-Machine Space Station Construction Concept. NASA TM-85762. (1984).
5. Bush, Harold G.; Mikulas, Martin M. Jr.; Wallson, Richard E.; and Jensen, J. Kermit. Conceptual Design of a Mobile Remote Manipulator System. NASA TM-86262. (1984).
6. Heard, Walter L. Jr.; Bush, Harold G.; Wallson, Richard E.; and Jensen, J. Kermit. A Mobile Work Station Concept for Mechanically Aided Astronaut Assembly of Large Space Trusses. NASA TP-2108. (1983).
7. Heard, Walter L. Jr. and Watson, Judith J. Results of the ACCESS Space Construction Shuttle Flight Experiment. AIAA Paper No. 86-1186-CP, Presented at the AIAA Space Systems Technology Conference, San Diego, California, June 9-12, 1986. (1986).
8. Card, Michael F.; Heard, Walter L. Jr.; and Akin, David L. Construction and Control of Large Space Structures. NASA TM-87689. (1986).
9. Russell, R. A.; Raney, J. P.; and DeRyder, L. J. A Space Station Structures and Assembly Verification Experiment - SAVE. NASA TM-89004. (1986).

ORIGINAL PAGE IS
OF POOR QUALITY

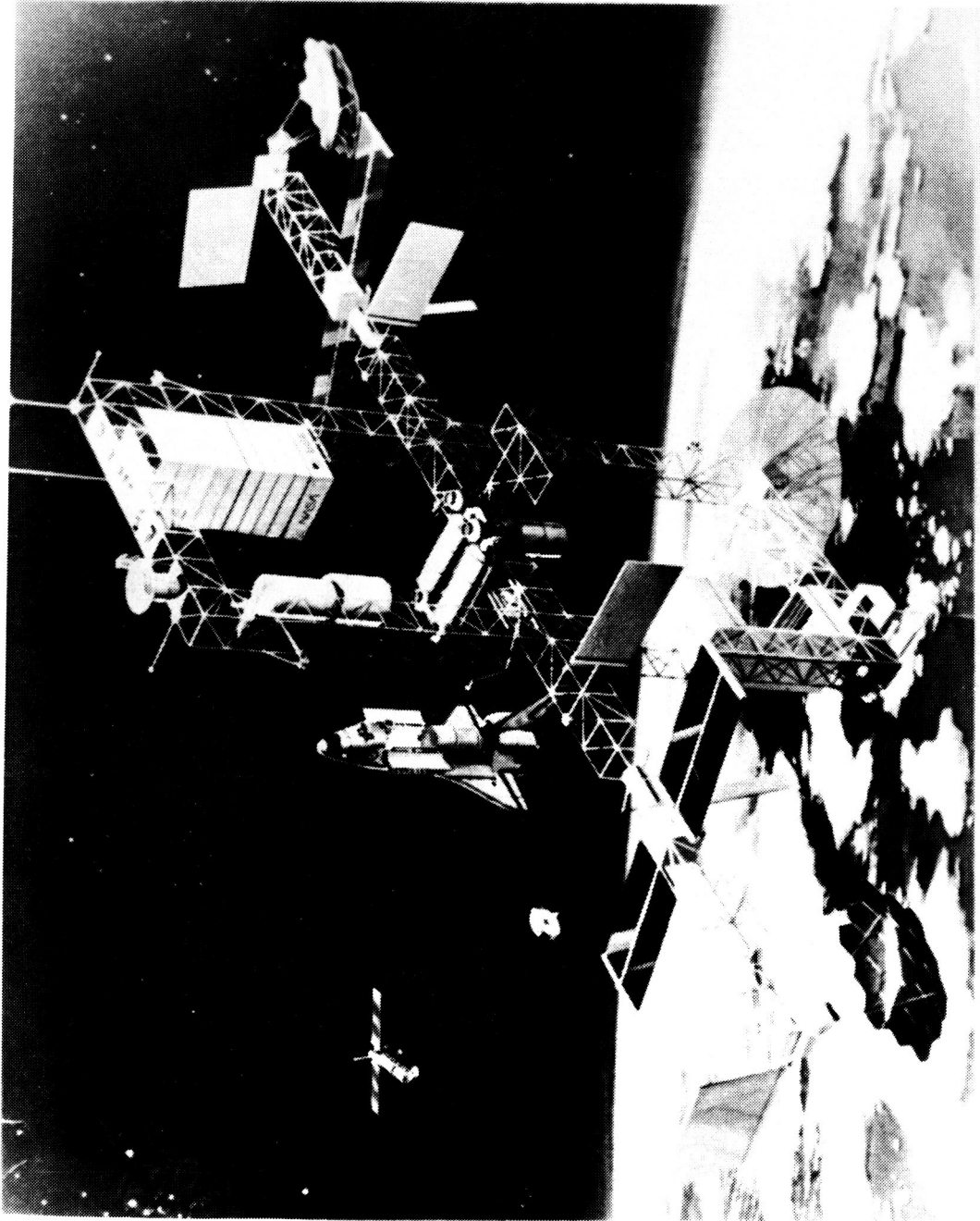

Fig. 1. Dual Keel Space Station constructed with 5-meter struts.

Truss data
 No. of struts 1100
 No. of nodes 330
 Truss mass 11,900 lbs
 5,400 Kg

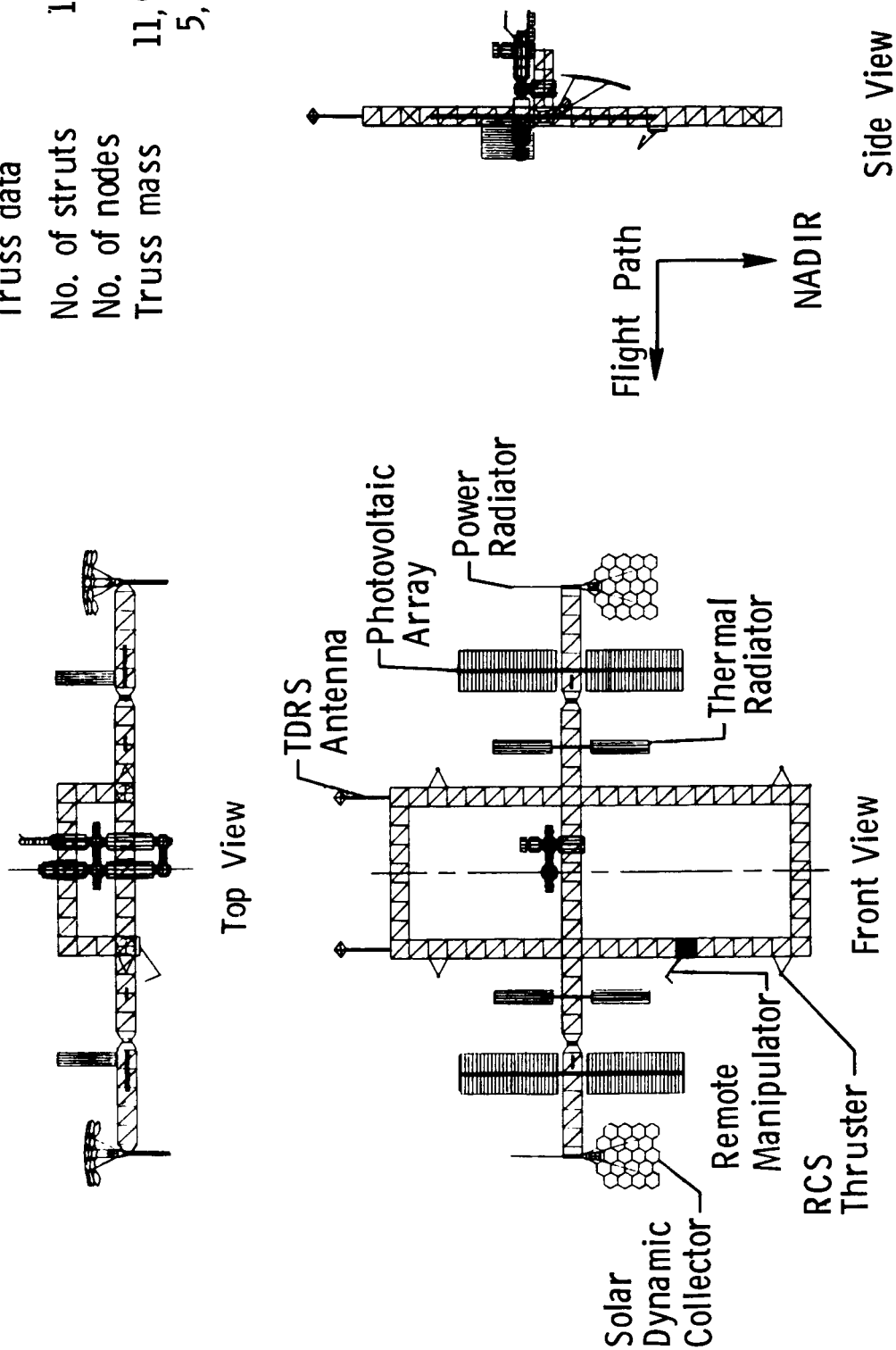

Fig. 2. Schematic of 5-meter truss, Dual Keel Space Station.

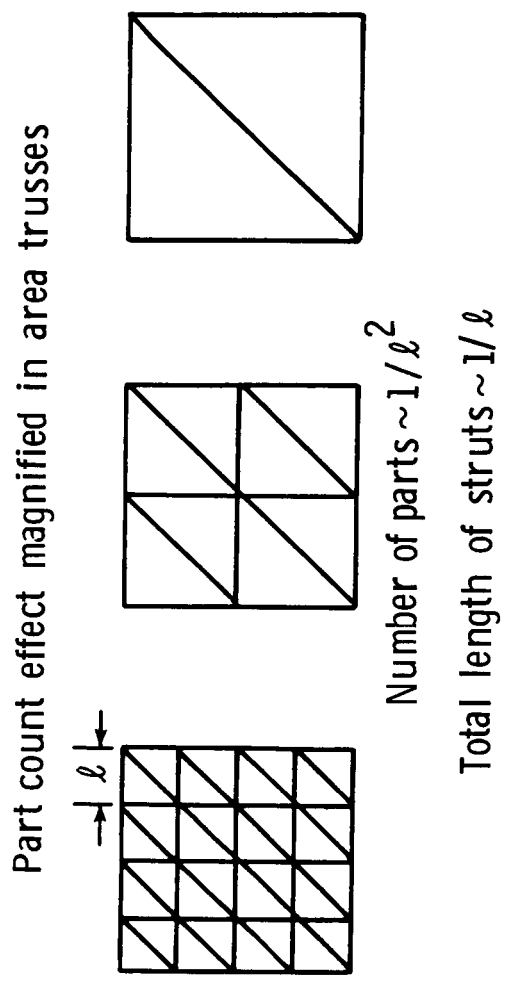
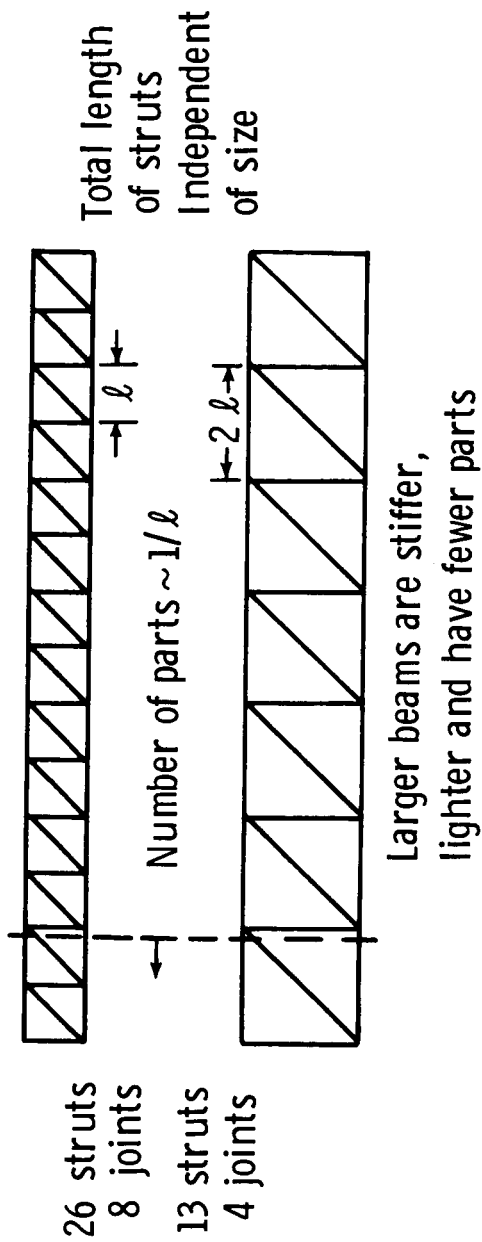

Fig. 3. Size effects in stiffness designed trusses.

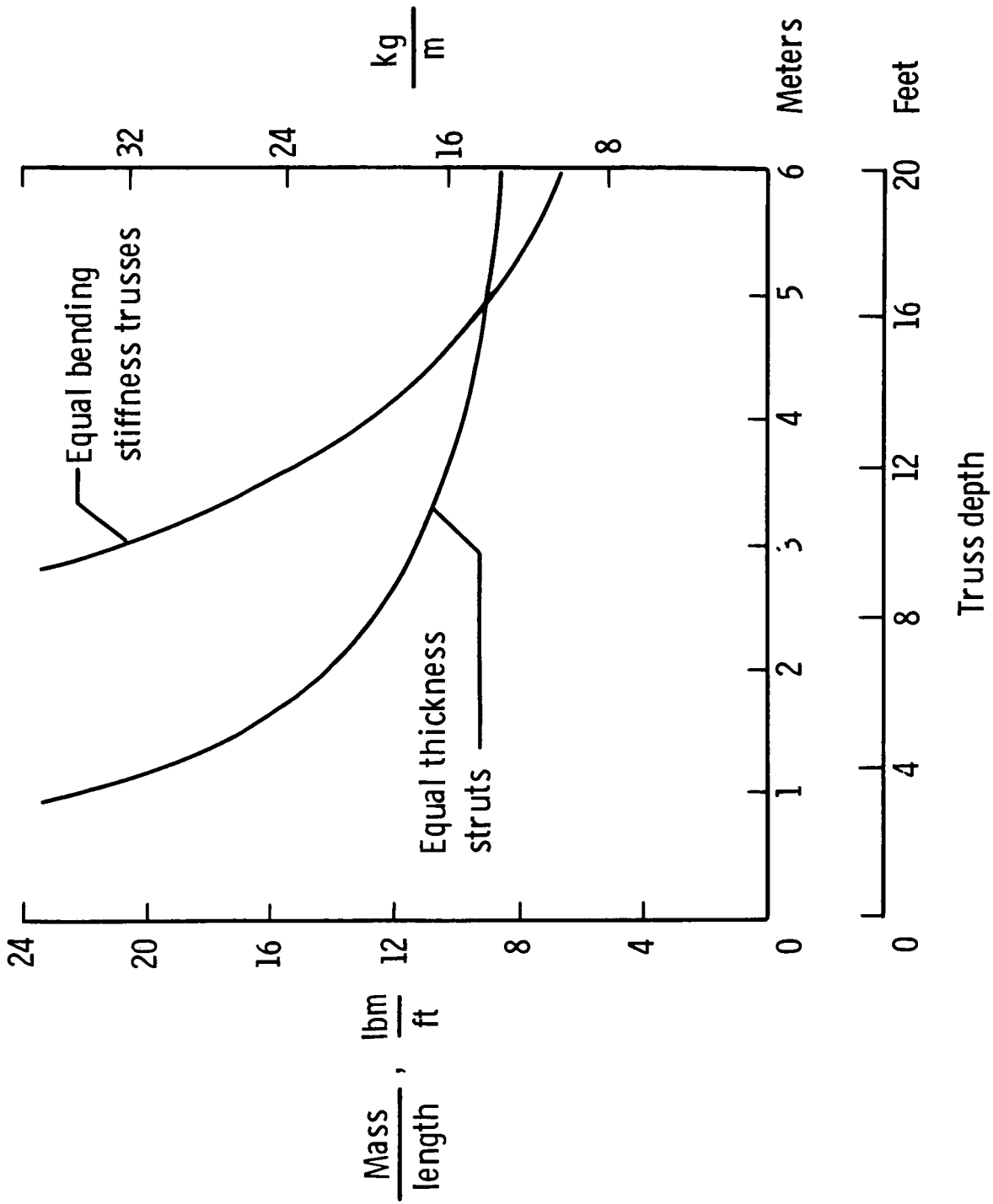

Fig. 4a. Effect of truss depth of structural mass.

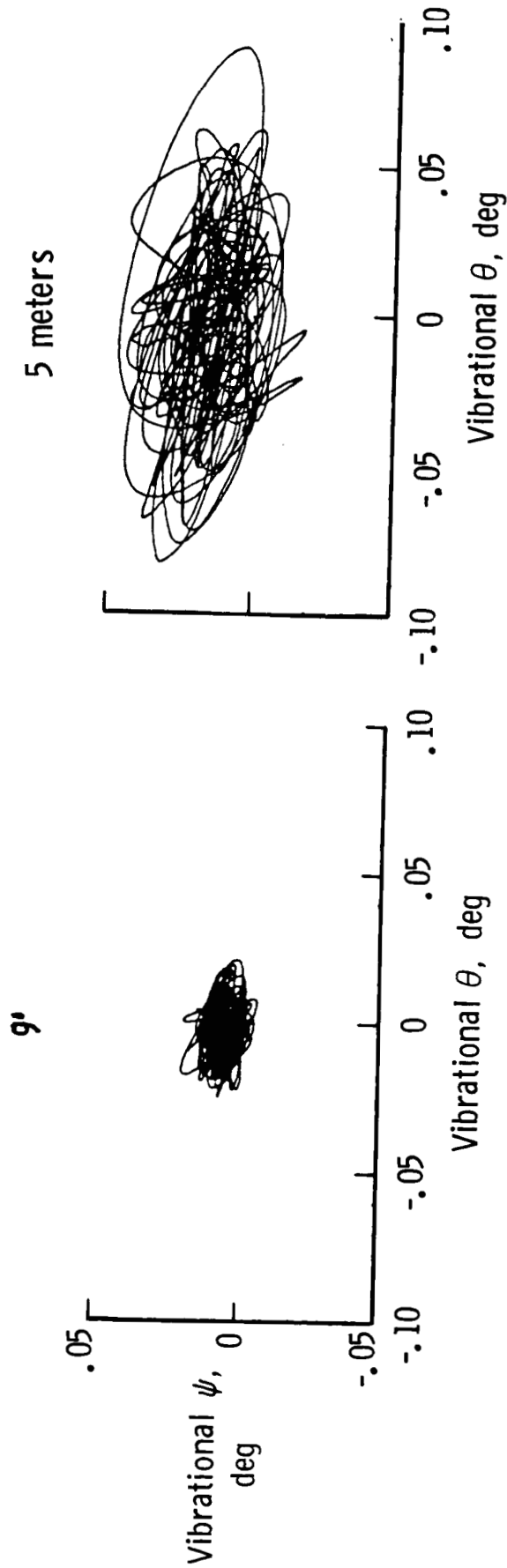
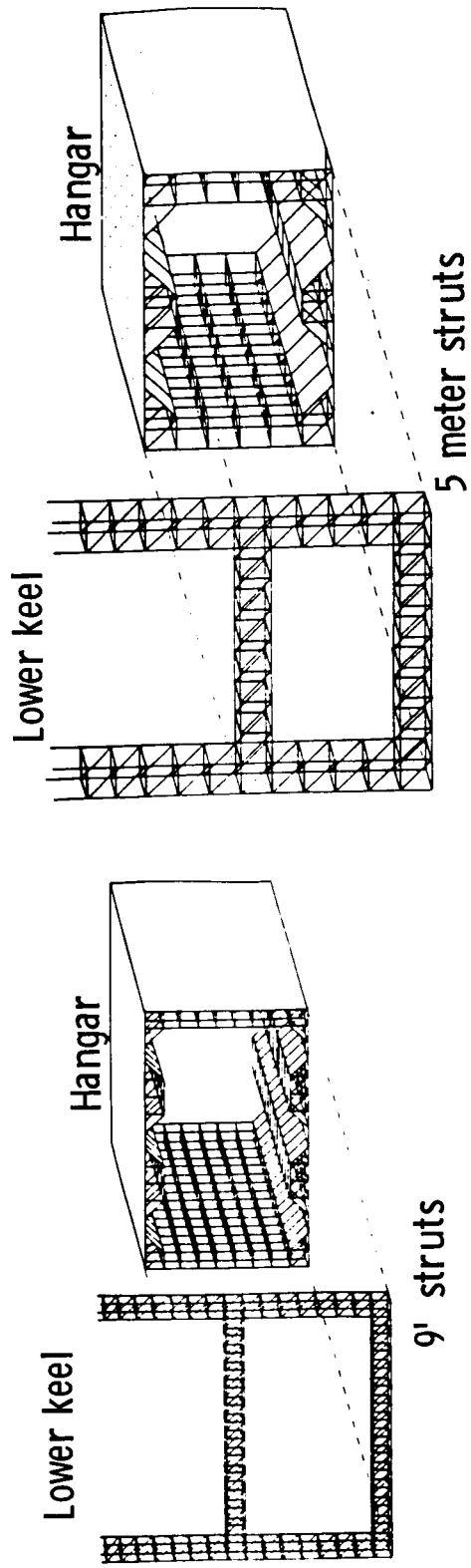

Fig. 4b. Flexible sun line variations at outer solar collector during reboost maneuver.



	9'	5 meter
Number of struts	4,660	1,590
Number of nodes	1,380	460
Mass	32,600 lbs 14,790 kg	16,000 lbm 7,260 kg
Construction time	78 hours	27 hours

Fig. 5. OTV Hangar construction comparison.

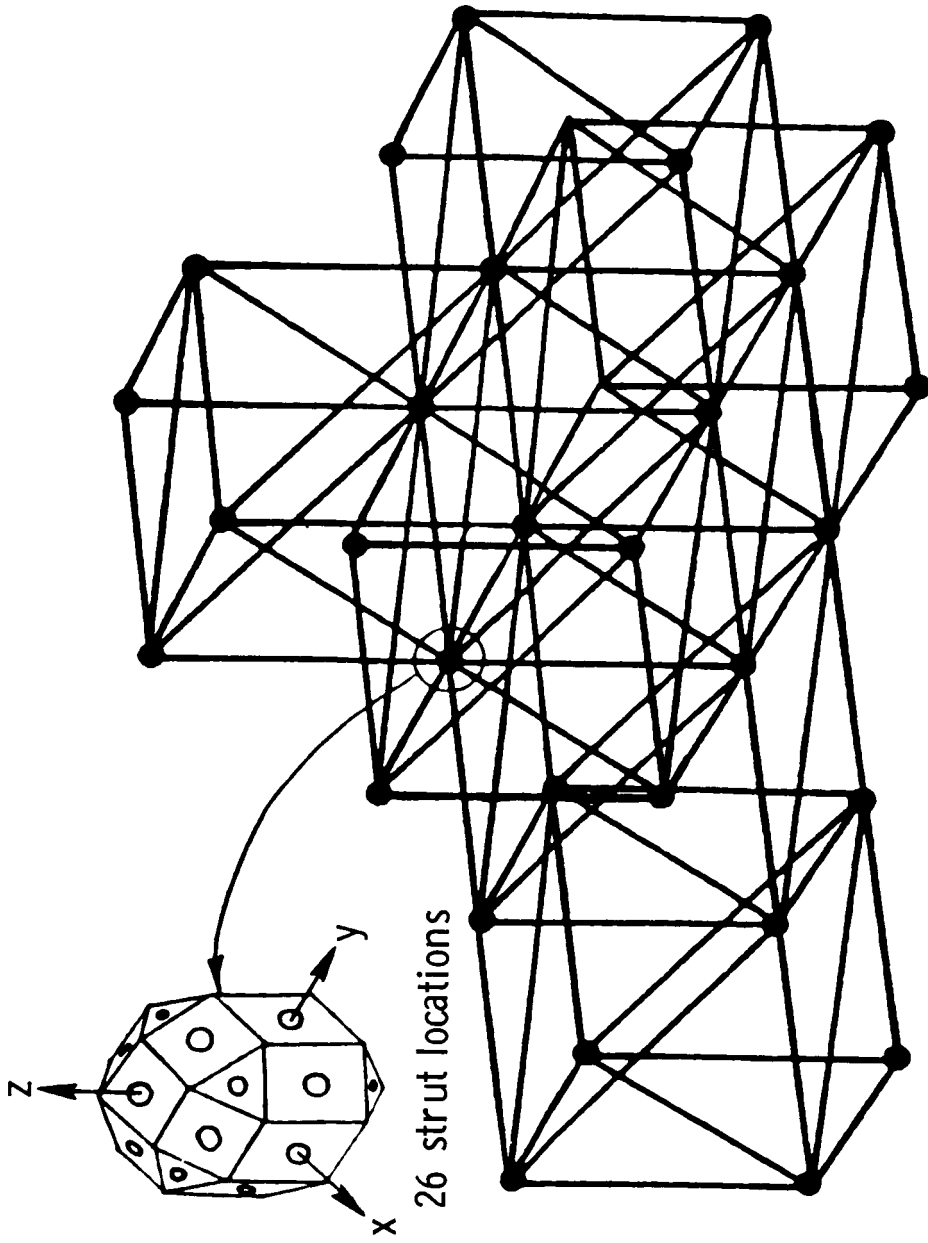

Fig. 6. 3-Dimensional node permits highly versatile growth.

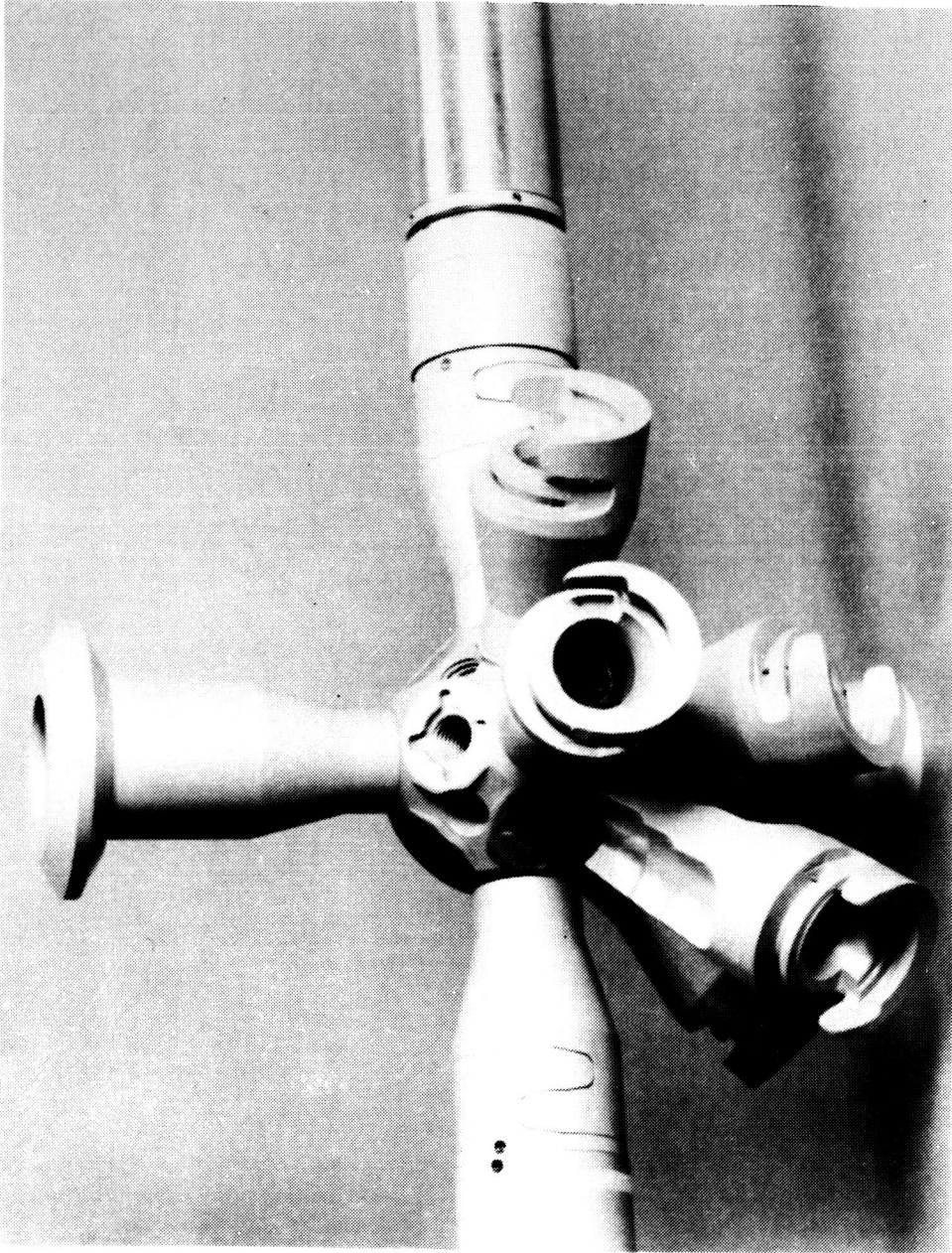

Fig. 7. 3-D Quick attachment erectable node.

ORIGINAL PAGE IS
OF POOR QUALITY

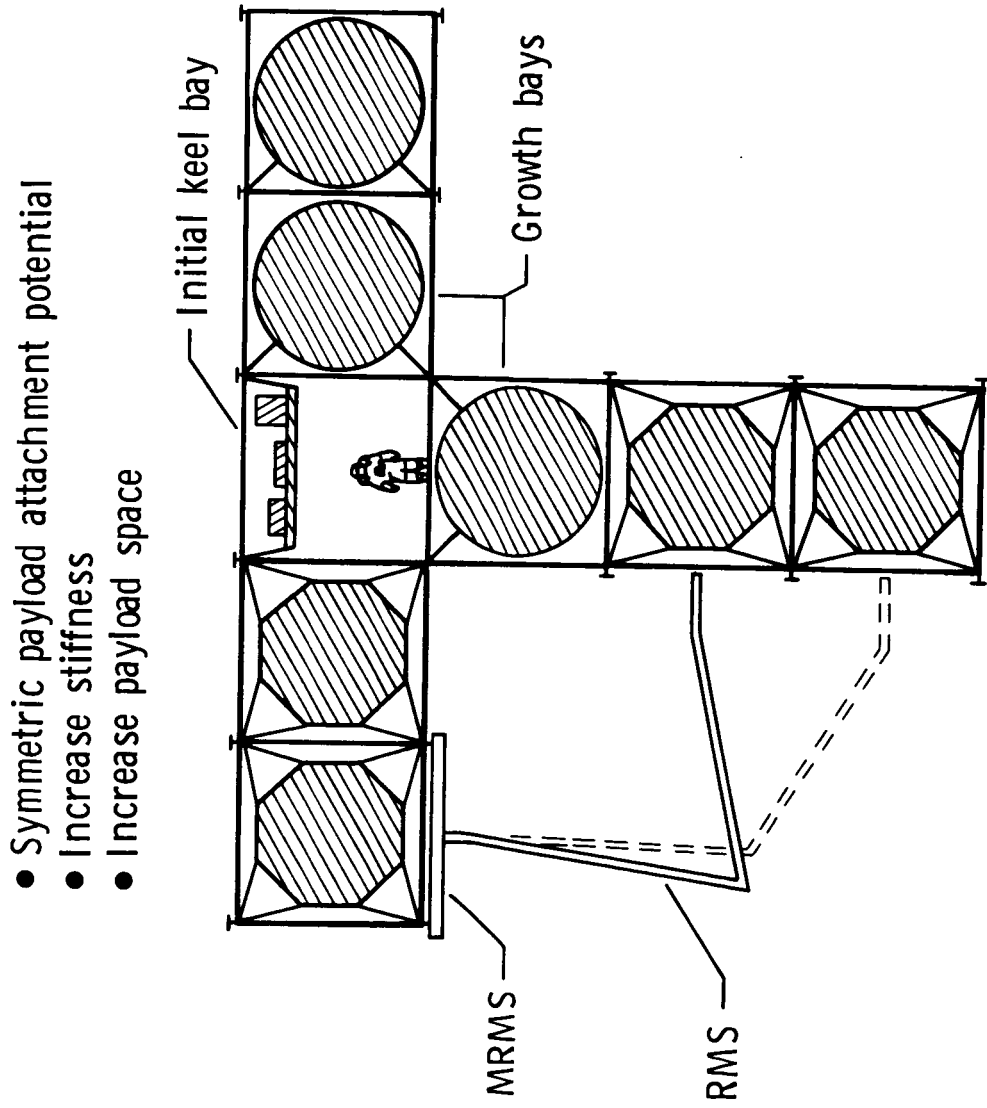
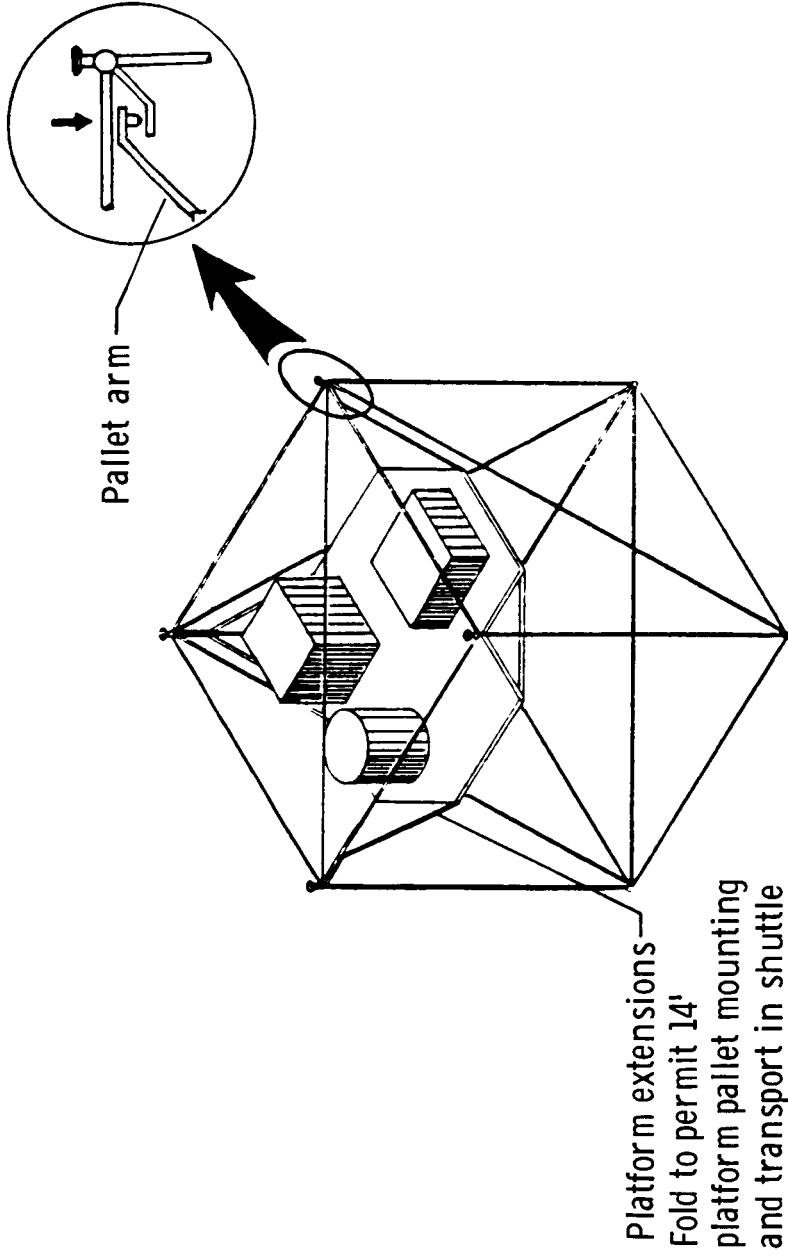

Fig. 8. 3-D Growth capability of 5-meter truss.



Platform extensions—
Fold to permit 14'
platform pallet mounting
and transport in shuttle

These shuttle-compatible pallets provide an 'LDEF-LIKE' scenario for accommodating a large number of flight experiments with minimal interference to space station operations

Fig. 9. Cargo bay size equipment pallets can be recessed in 5-meter truss to minimize station congestion.

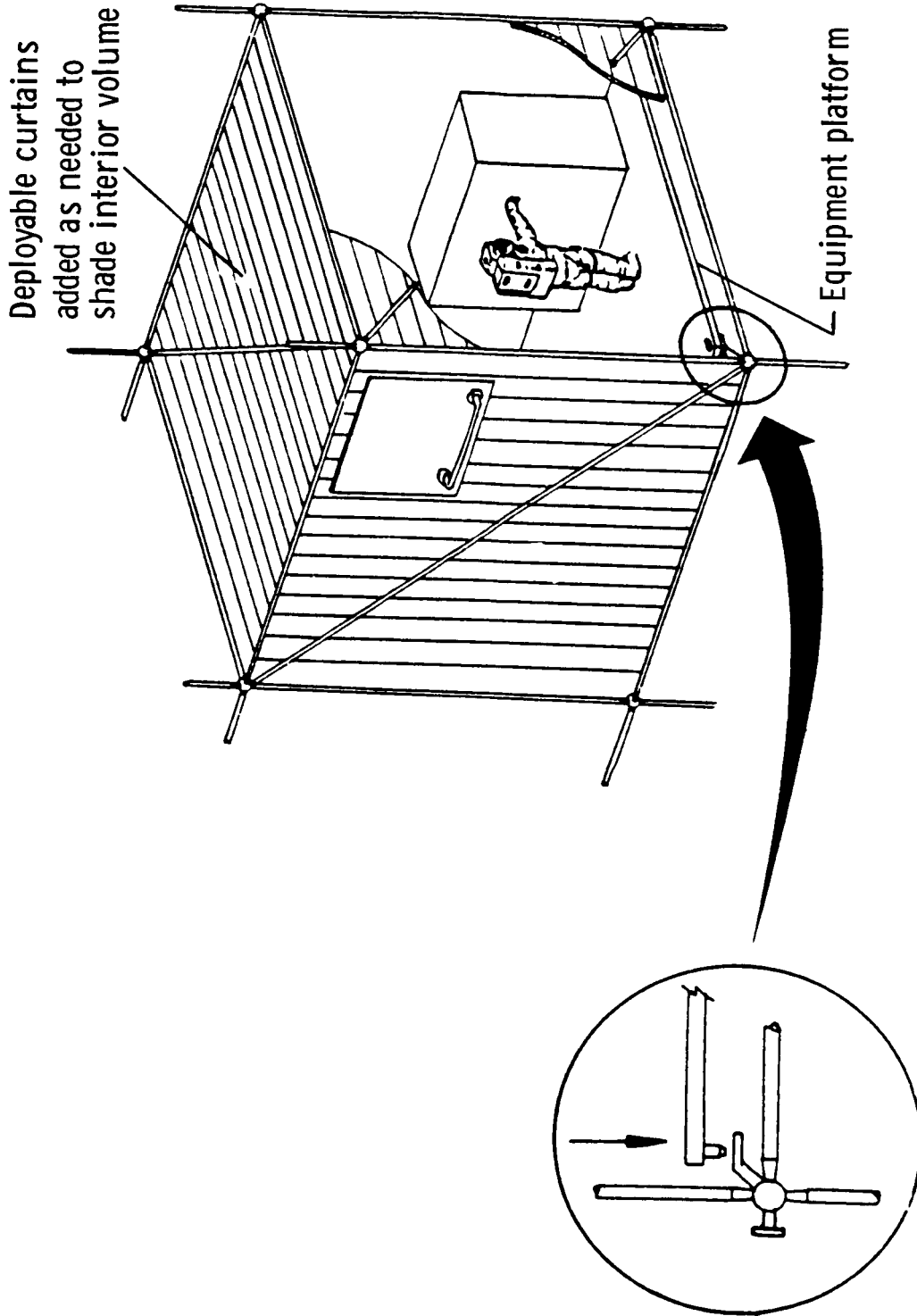

Fig. 10. 5-Meter structure provides useable interior volume.

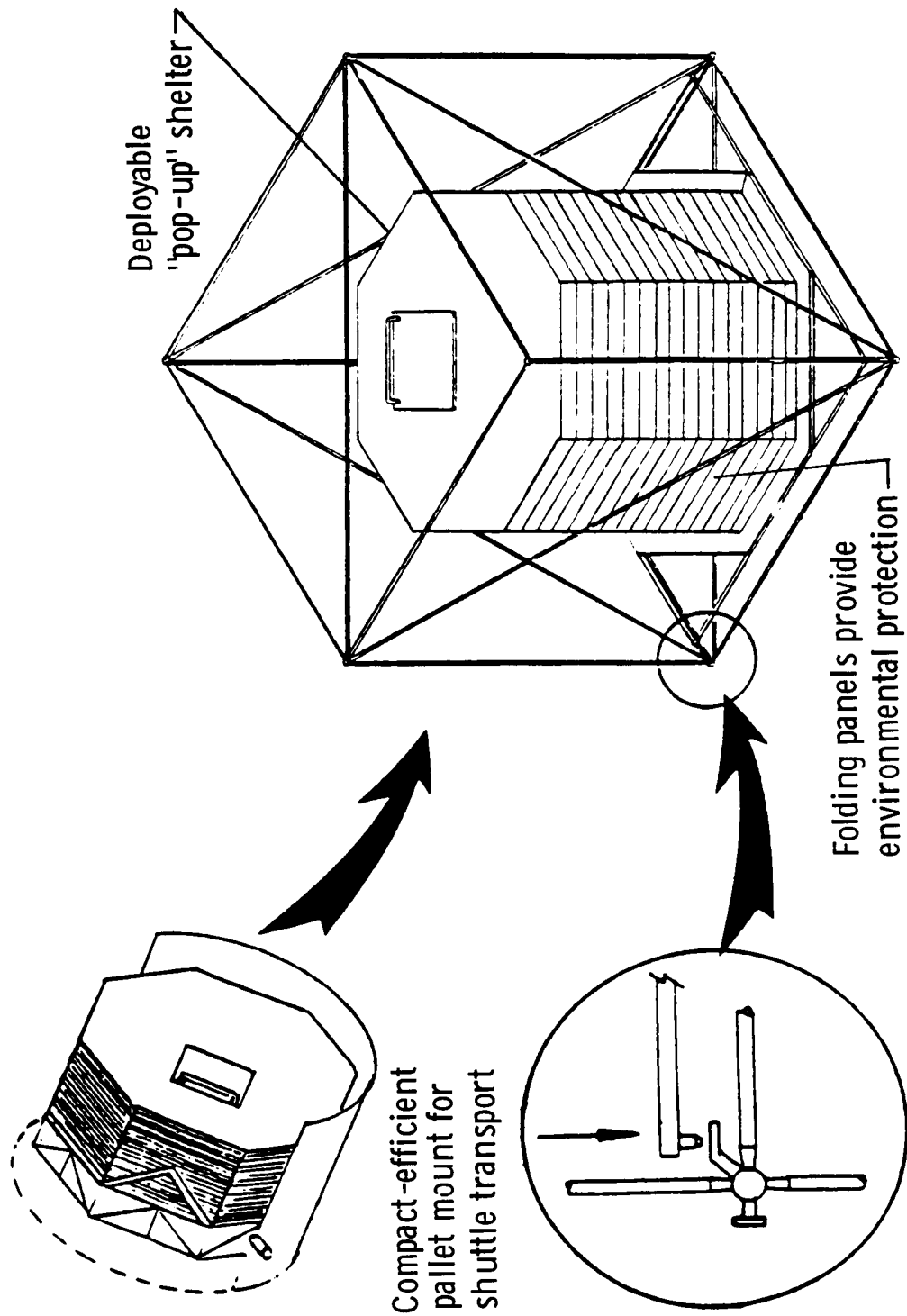
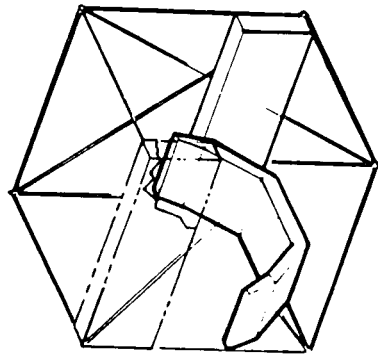
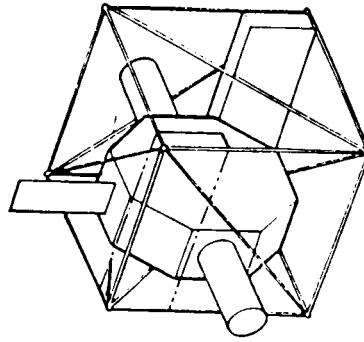

Fig. 11. 5-Meter truss can accommodate cargo bay size environmental protection shelter.



Launch pallets



Ground integrated subsystem modules

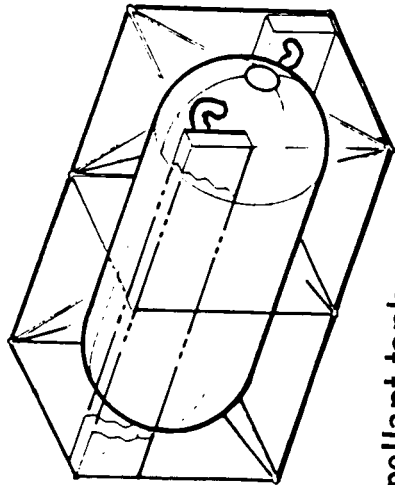

Propellant tank

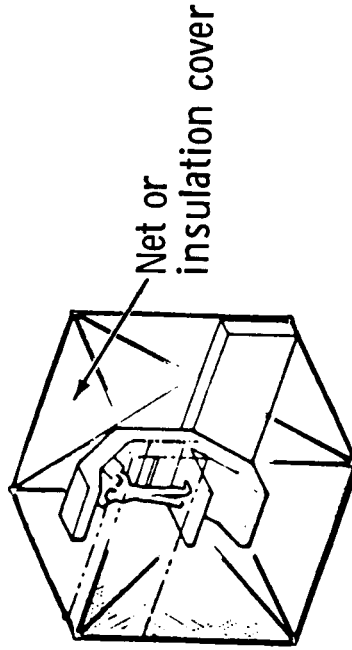

Maintenance/ storage area

Fig. 12. Cargo bay size payloads can be stored on interior of 5-meter truss.

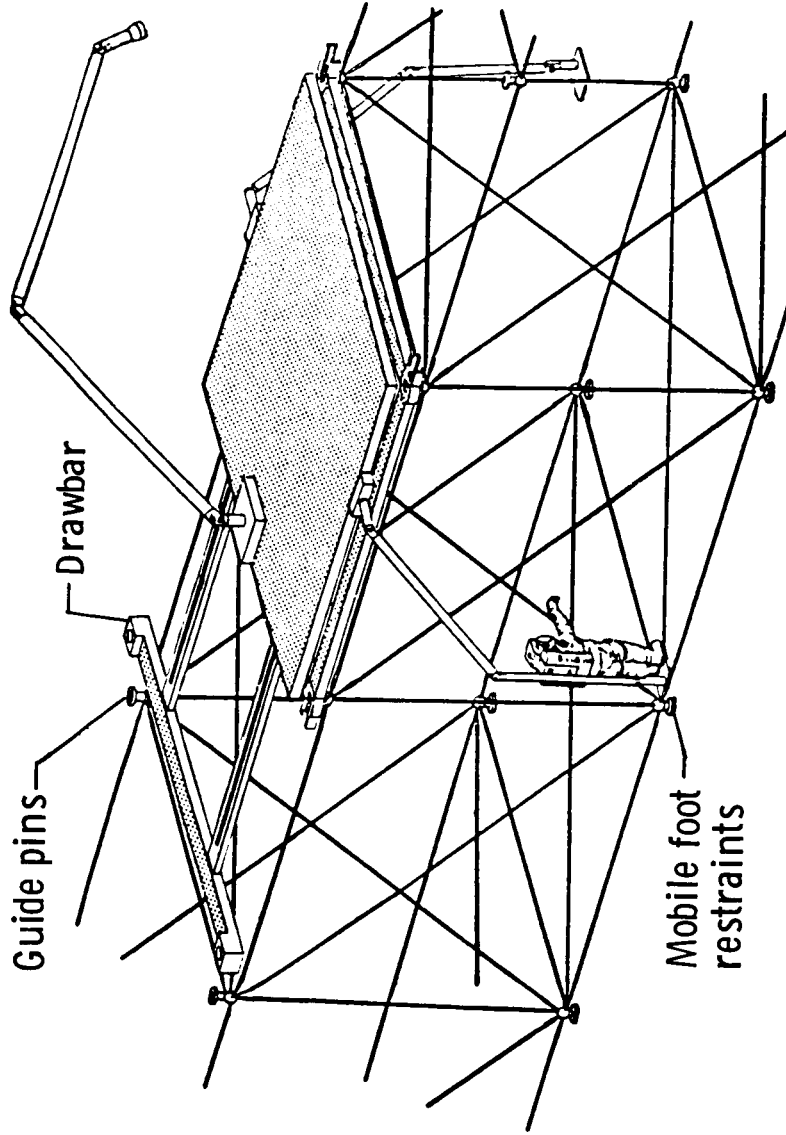

Fig. 13. Mobile remote manipulator system attached to 5-meter truss.

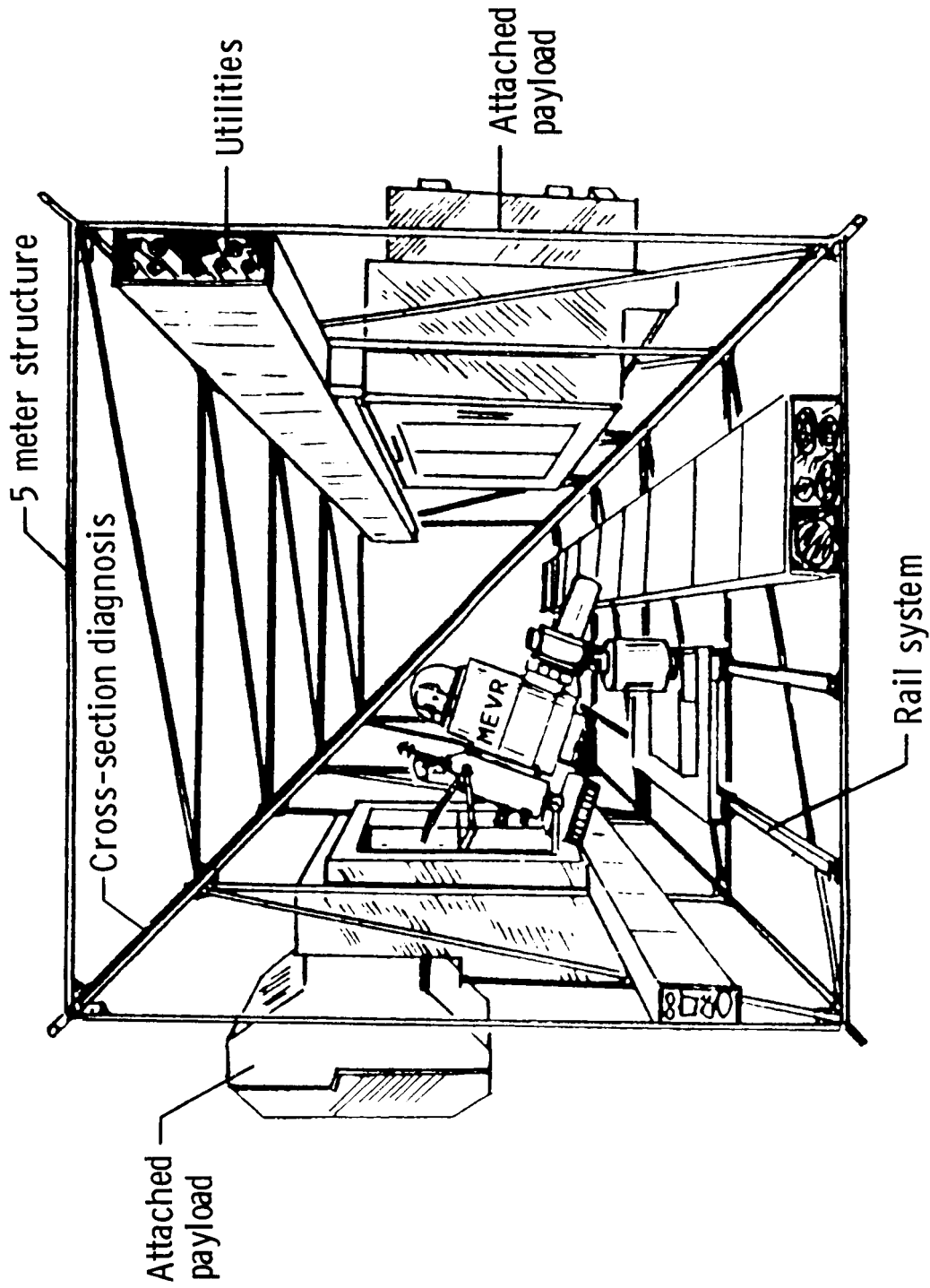

Fig. 14. 5-Meter truss provides sufficient room for an interior mobile transporter.

ORIGINAL PAGE IS
OF POOR QUALITY

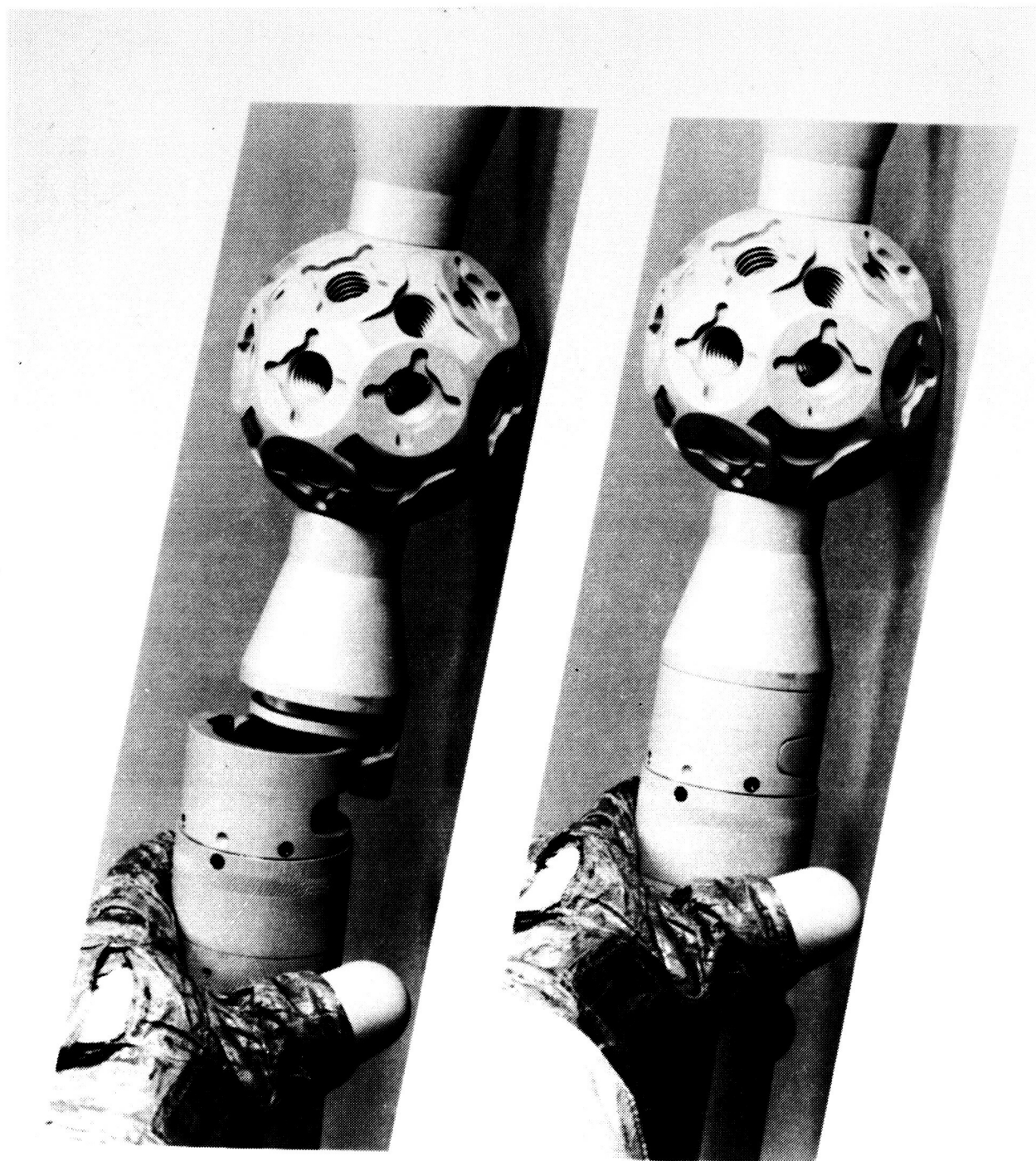

Fig. 15. Quick-attachment joints designed for astronaut glove handling.

ORIGINAL PAGE IS
OF POOR QUALITY

ORIGINAL PAGE IS
OF POOR QUALITY

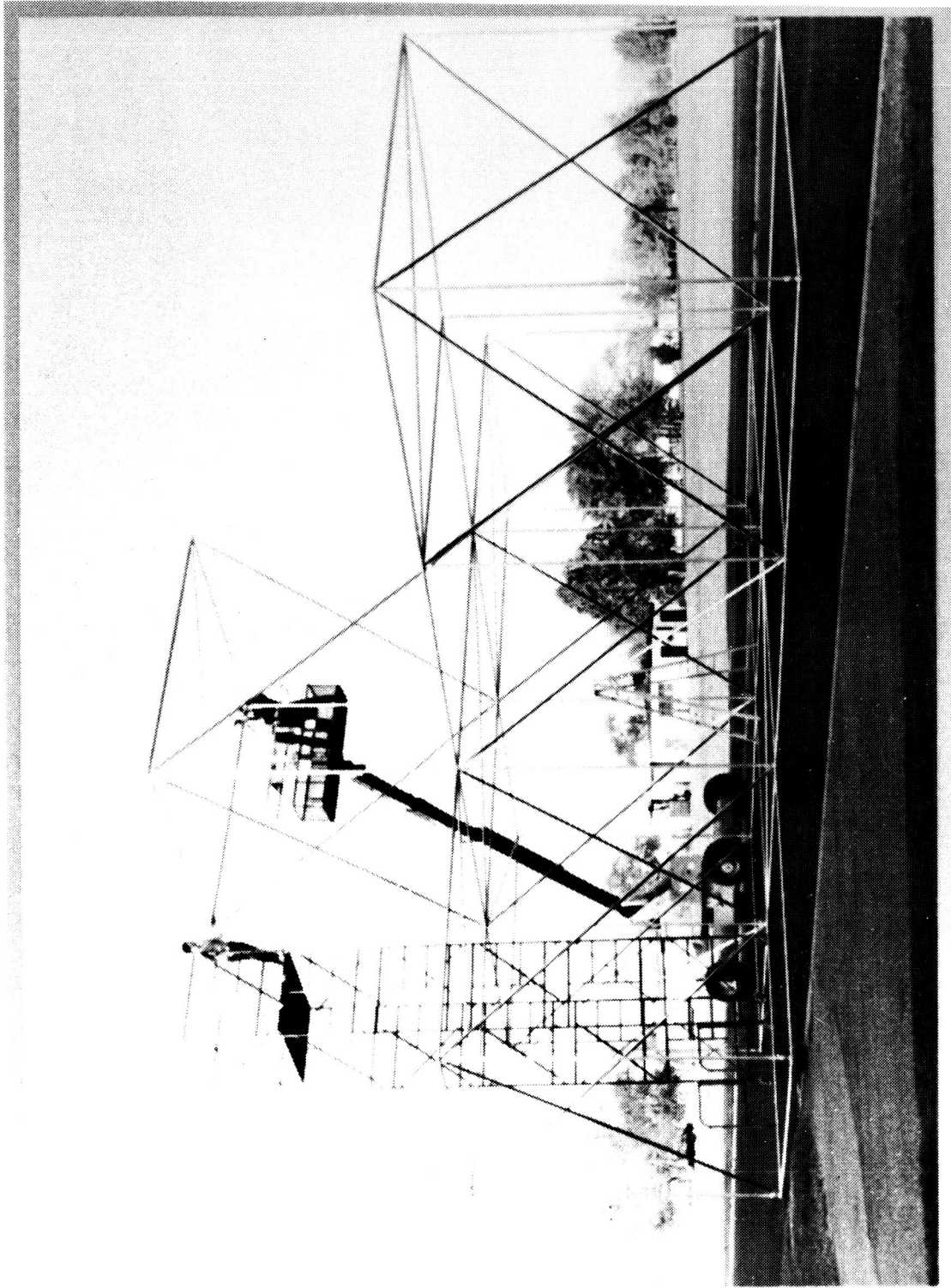

Fig. 16. Space Station structural model.

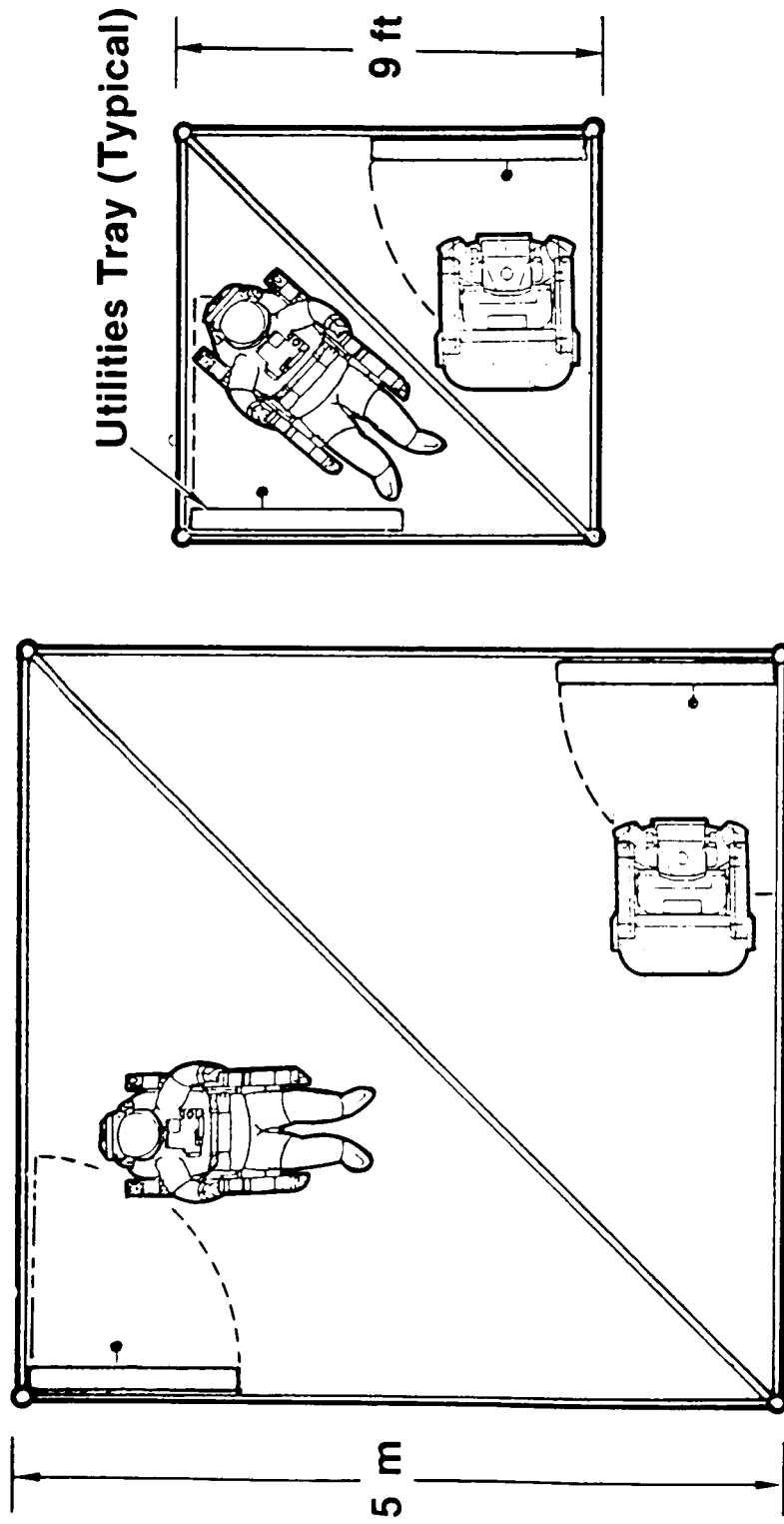

Fig. 17. 5-Meter truss provides ample room for EVA operations.

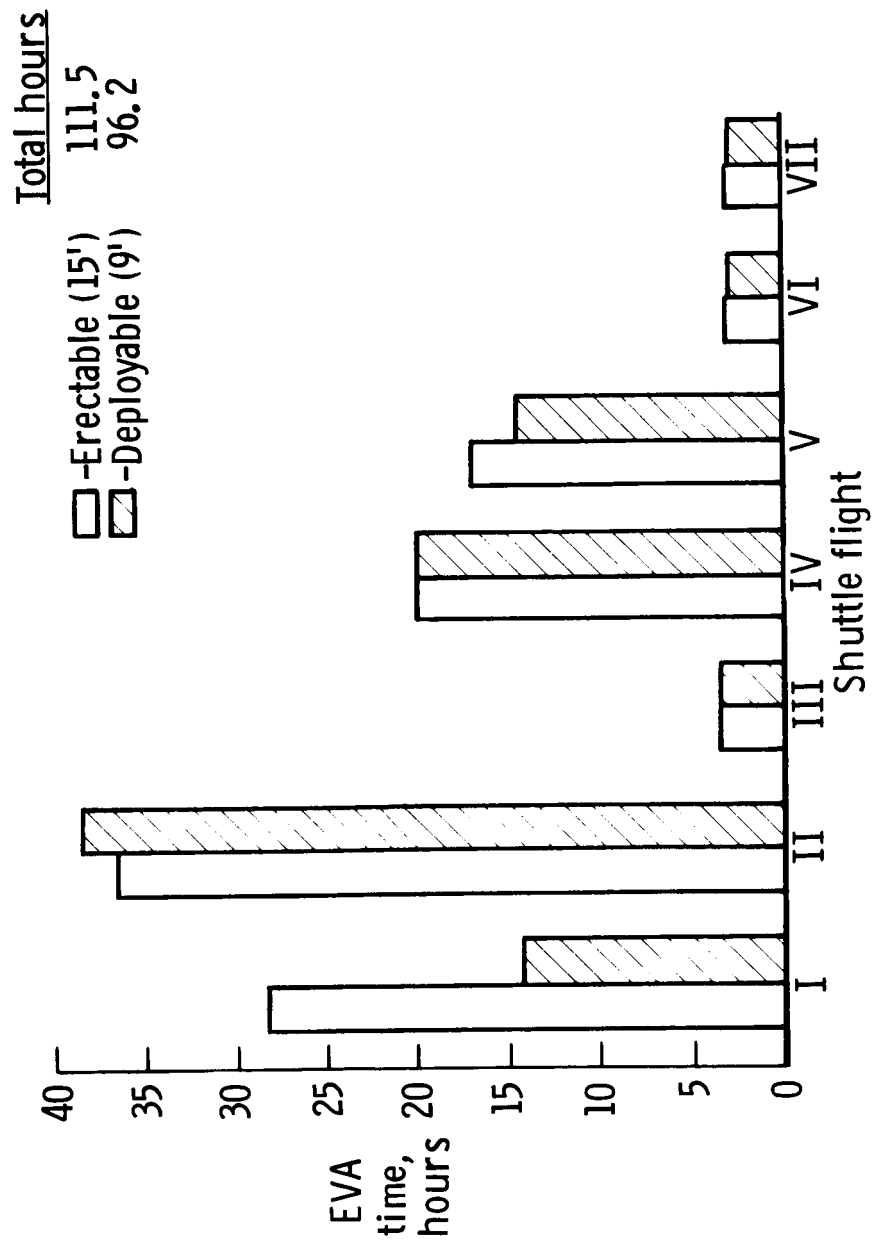

Fig. 18. Comparison of EVA hours to construct IOC Space Station configurations.

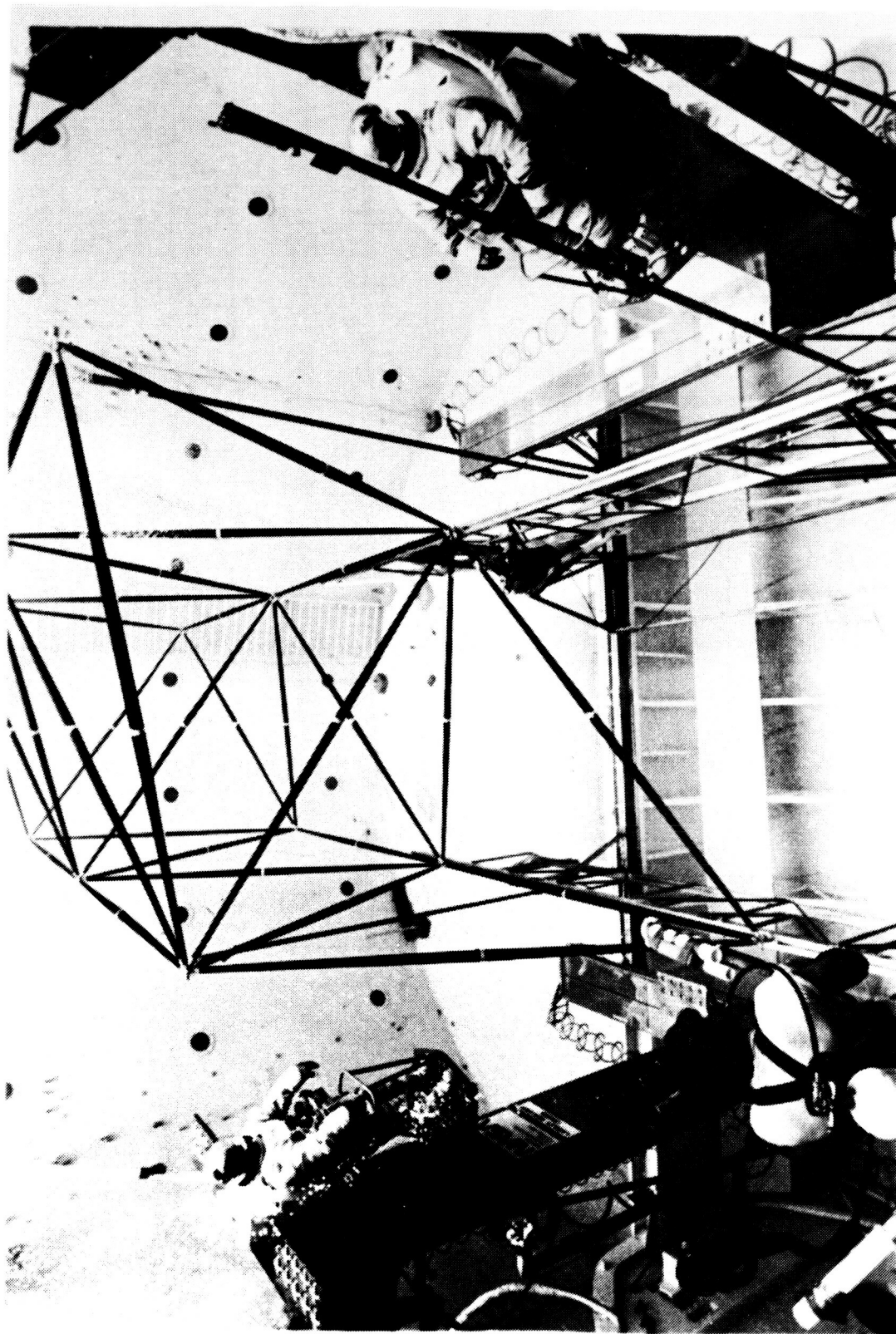

Fig. 19. 38-Strut truss assembly in mobile work station.

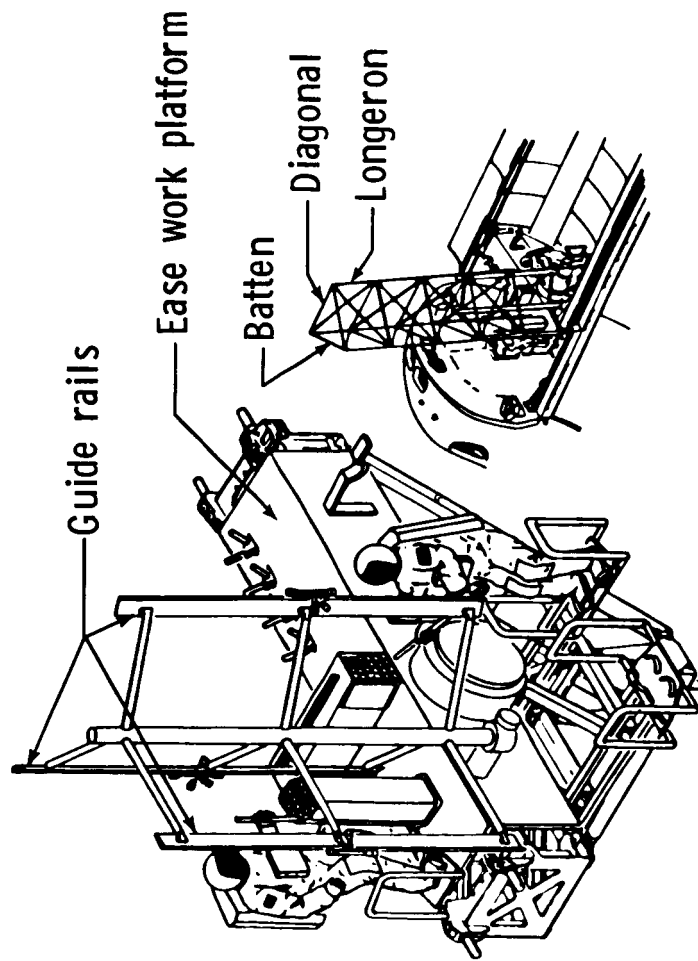

Fig. 20. ACCESS baseline experiment setup.

ORIGINAL PAGE IS
OF POOR QUALITY

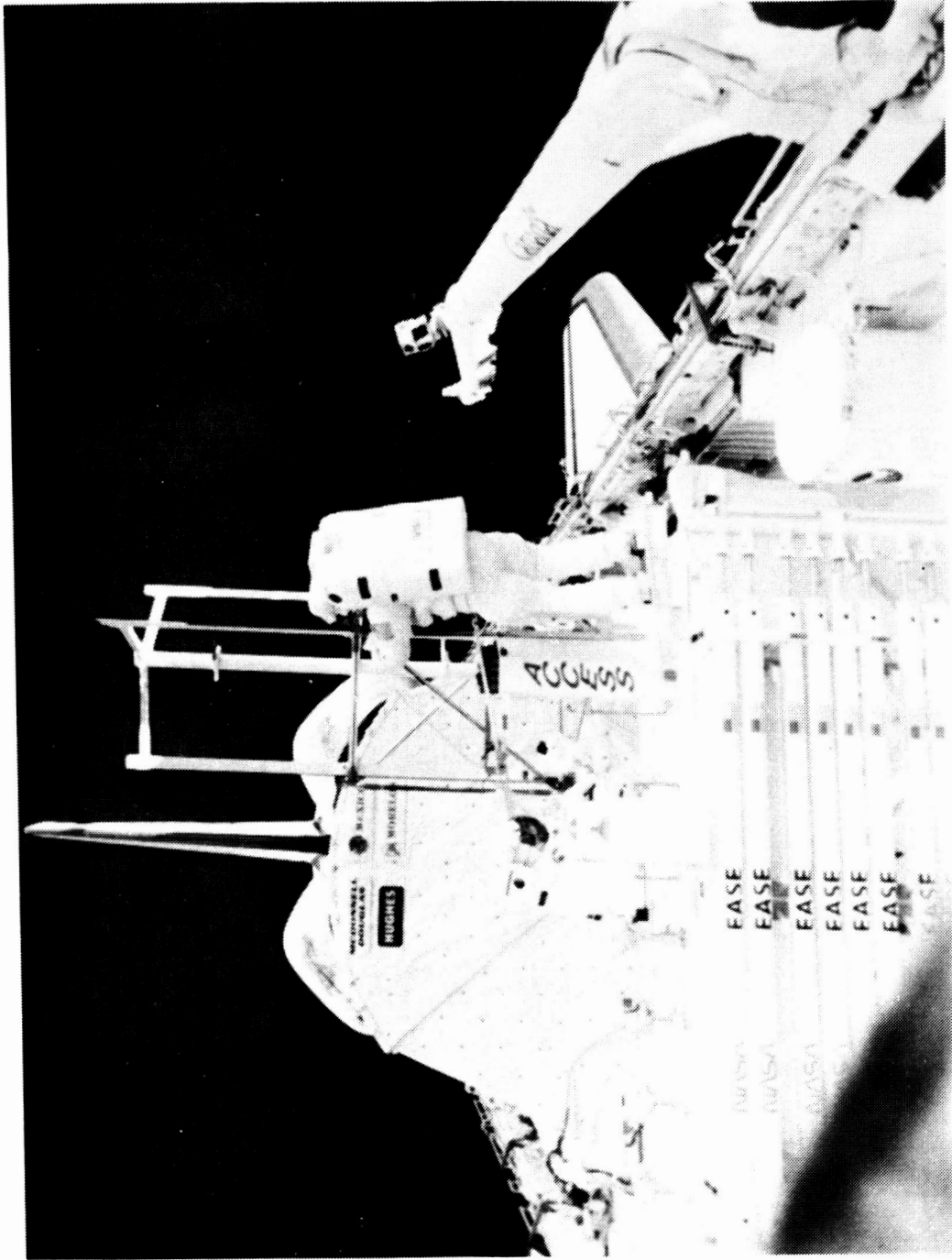

Fig. 21a. Initiation of ACCESS truss construction experiment.

ORIGINAL PAGE IS
OF POOR QUALITY

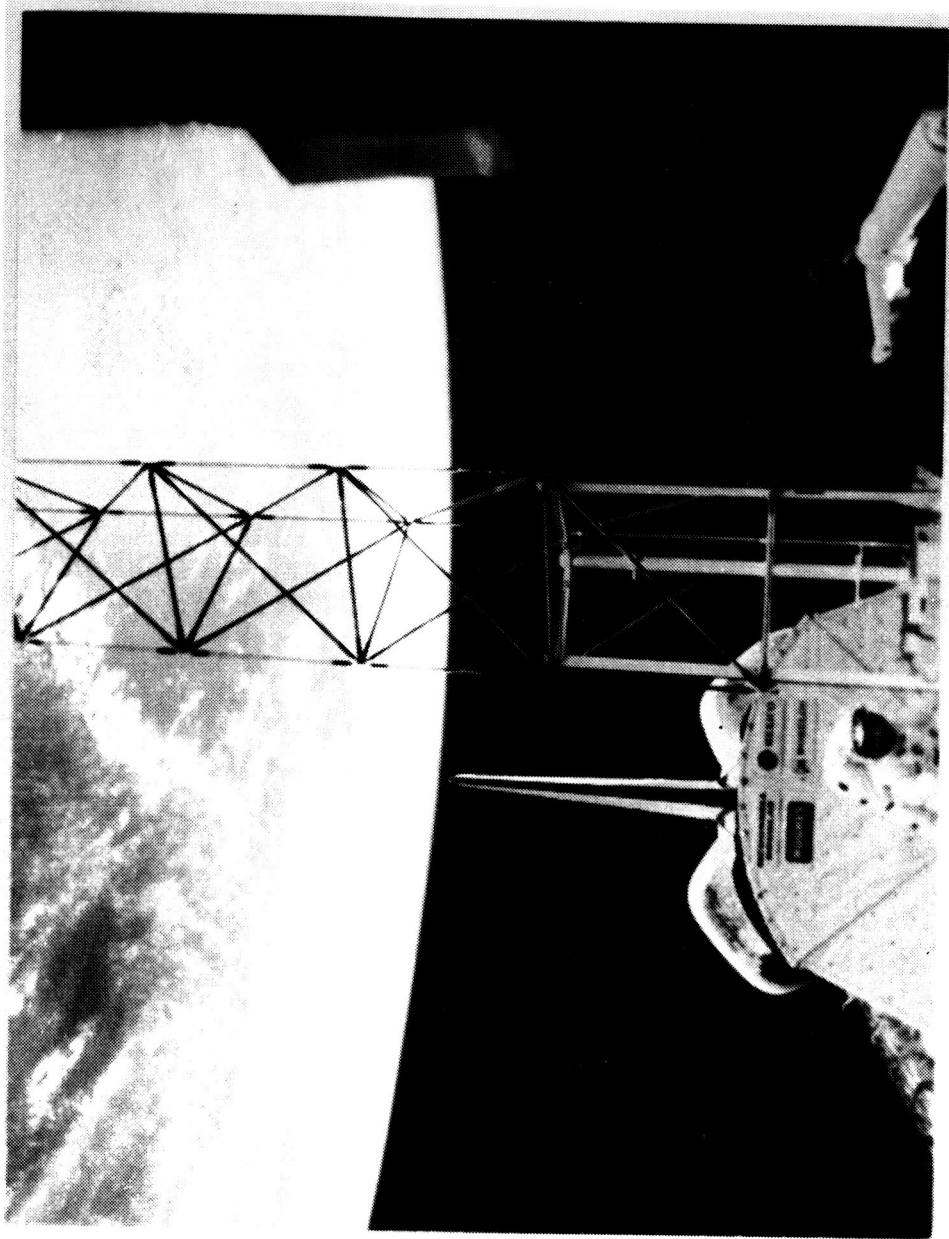

Fig. 21b. Photograph of on-orbit ACCESS assembly.

Preliminary results

Task	Time min:sec		
	NBS	NBS	Flight
	Avg all tests	Trained	Trained
Setup	4:00	3:04	3:31
Assemble 10 bays	30:13	21:44	25:27
Disassemble 10 bays	18:45	15:00	18:52
Stow and close up	5:23	4:30	4:41
	<hr/>	<hr/>	<hr/>
	58:21	44:18	52:31

Fig. 22. Correlation of space truss construction time for ACCESS.

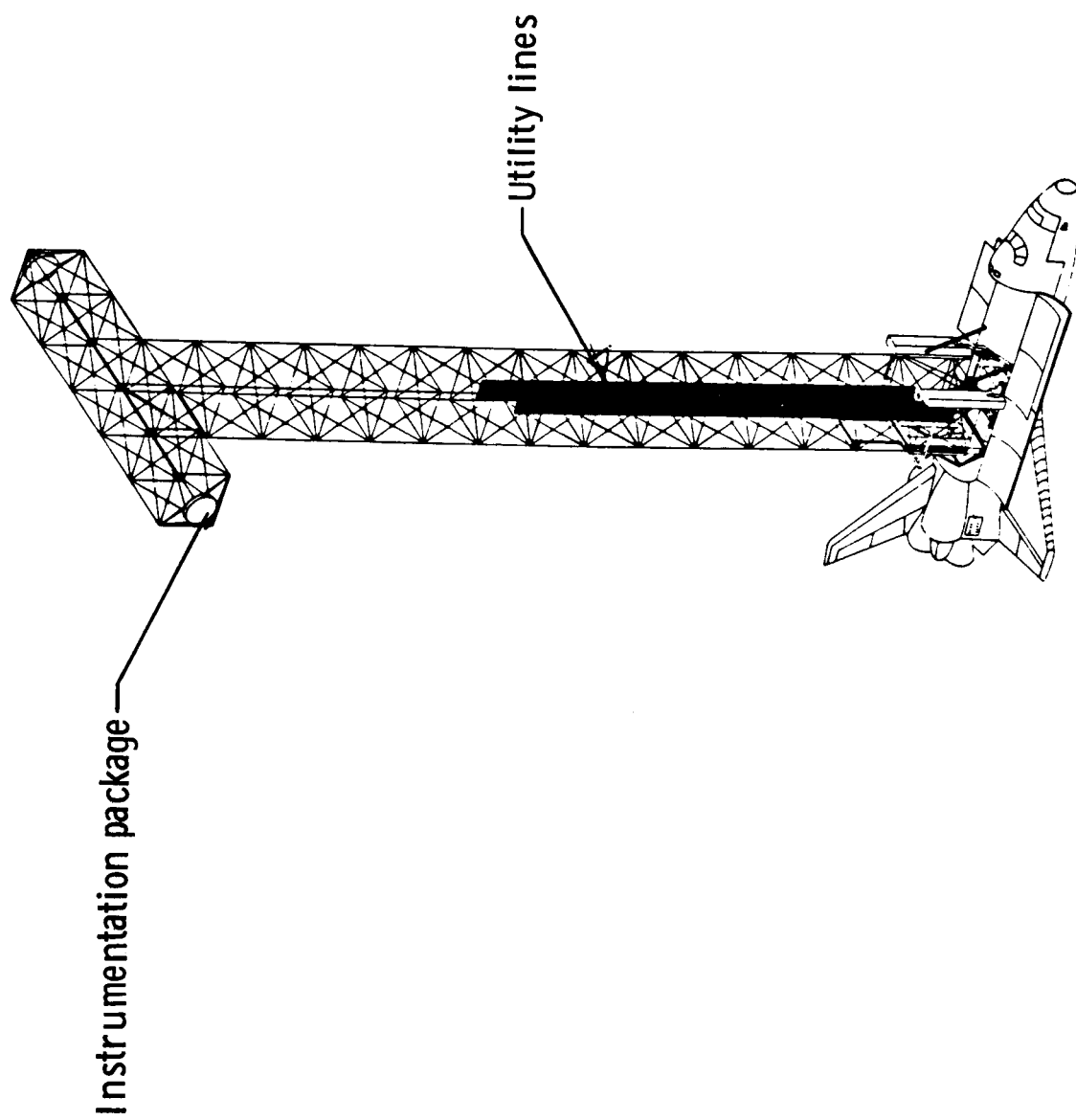
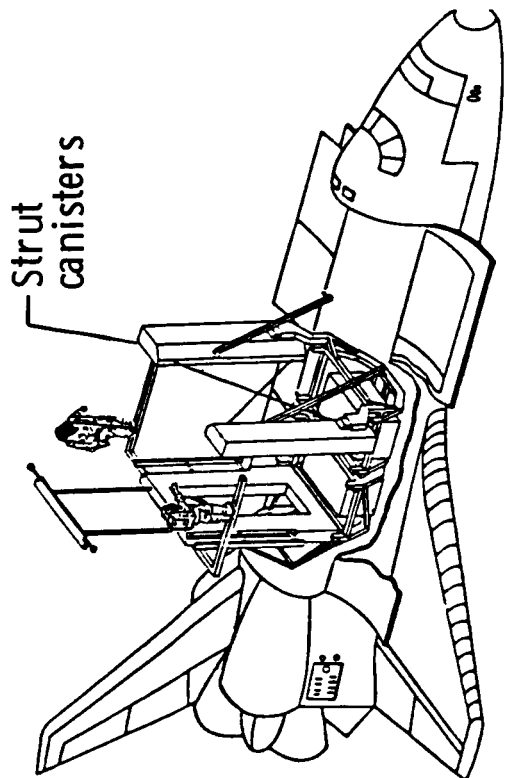
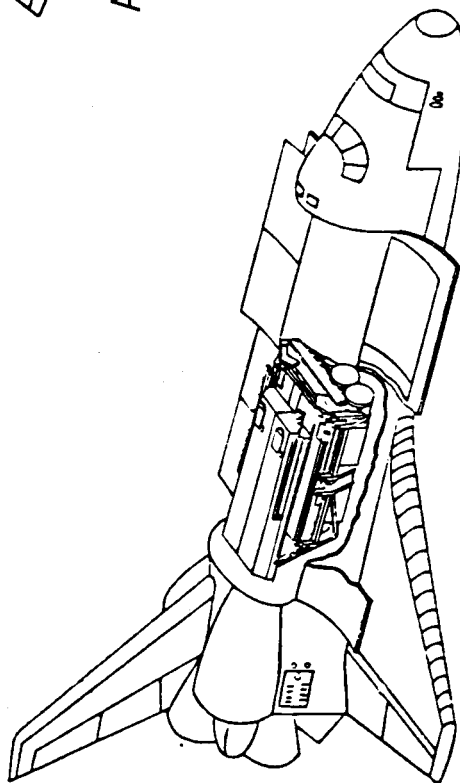

Fig. 23. 16-Bay-long truss flight experiment.



Automatic deployment of assembly fixture



Package assembly fixture and truss

Fig. 24. Packaged flight experiment and assembly fixture.

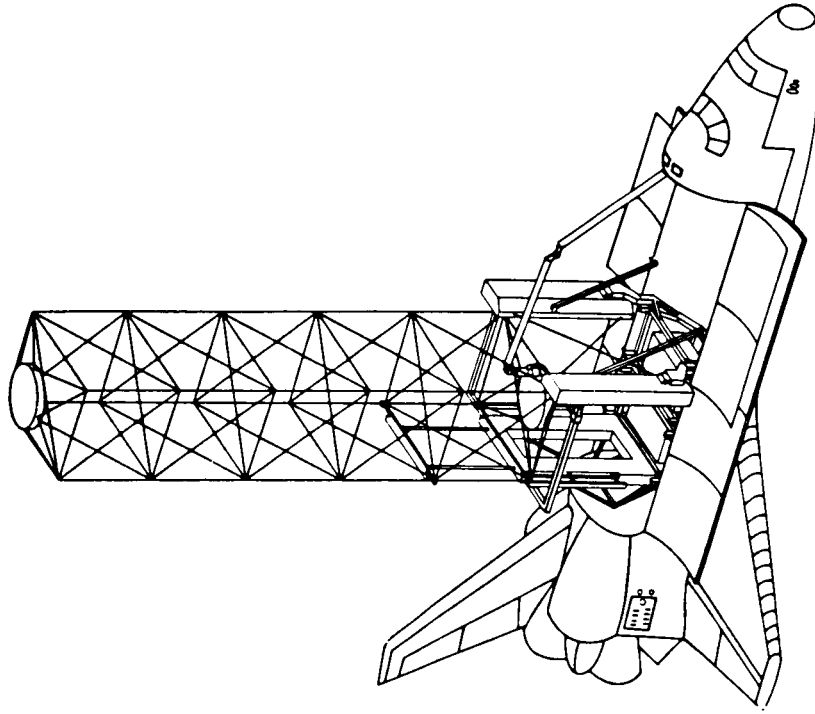

Five bays of erected truss

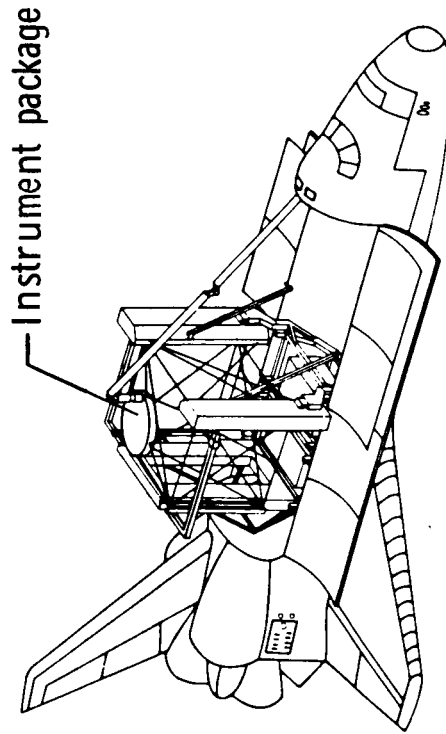

Erection of first bay

Fig. 25. Initial assembly of 5-meter erectable truss.

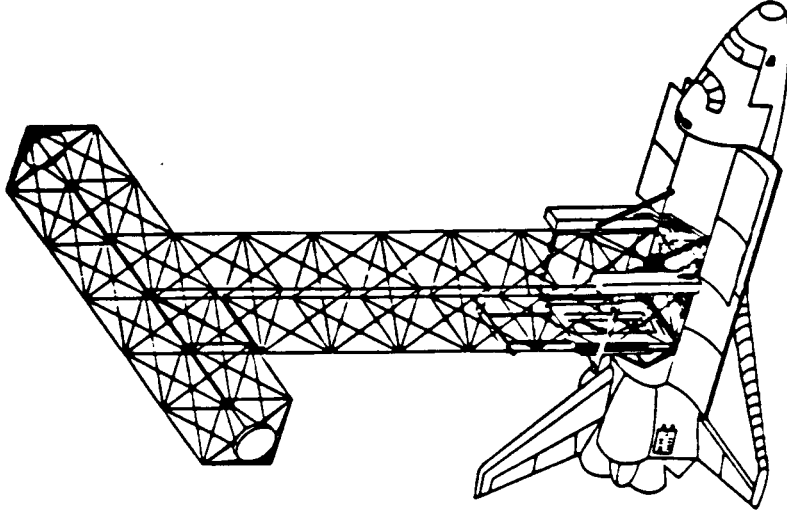

Truss after 5 hr EVA

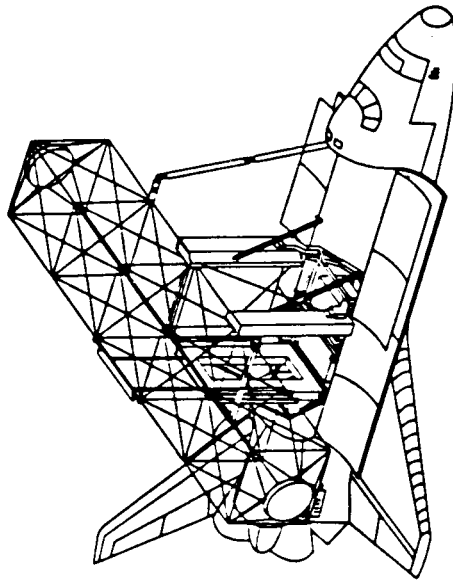

Five bays rotated and reattached

Fig. 26. 12 Bays of erected truss after a 5-hour EVA.

Standard Bibliographic Page

1. Report No. NASA TM-89043	2. Government Accession No.	3. Recipient's Catalog No.	
4. Title and Subtitle Design, Construction and Utilization of a Space Station Assembled from 5-Meter Erectable Struts		5. Report Date October 1986	
		6. Performing Organization Code 506-43-41-02	
7. Author(s) Martin M. Mikulas, Jr. and Harold G. Bush		8. Performing Organization Report No.	
		10. Work Unit No.	
9. Performing Organization Name and Address NASA Langley Research Center Hampton, VA 23665		11. Contract or Grant No.	
		13. Type of Report and Period Covered Technical Memorandum	
12. Sponsoring Agency Name and Address National Aeronautics and Space Administration Washington, DC 20546		14. Sponsoring Agency Code	
		15. Supplementary Notes	
16. Abstract <p>This paper presents the primary characteristics of the 5-meter erectable truss which has been baselined for the Space Station. The relatively large 5-meter truss dimension was chosen to provide a deep beam for high bending stiffness yet provide convenient mounting locations for space shuttle cargo bay size payloads which are 14.5 ft. (4.4 m) in diameter. Truss nodes and quick-attachment erectable joints are described which provide for evolutionary three-dimensional growth and for simple maintenance and repair. A mobile remote manipulator system is described which is provided to assist in station construction and maintenance. A discussion is also presented of the construction of the Space Station and the associated EVA time.</p>			
17. Key Words (Suggested by Authors(s)) Truss Structures, Space Station Space Structures, EVA Time		18. Distribution Statement Unclassified - Unlimited Subject Category 18	
19. Security Classif.(of this report) Unclassified	20. Security Classif.(of this page) Unclassified	21. No. of Pages 39	22. Price A03