

IN-39813
P-44

JPL Publication 86-41

DOE/ET 29372-6
Distribution Category UC-97b

Distribution System Simulator

K. A. Bahrami
H. Kirkham
S. Rahman

(NASA-CR-179918) DISTRIBUTION SYSTEM
SIMULATOR (Jet Propulsion Lab.) 44 p

N87-11940

CSCI 09C

G3/33 Unclass
44934

August 15, 1986

Prepared for
U.S. Department of Energy
Through an Agreement with
National Aeronautics and Space Administration
by
Jet Propulsion Laboratory
California Institute of Technology
Pasadena, California

Distribution System Simulator

K. A. Bahrami
H. Kirkham
S. Rahman

August 15, 1986

Prepared for
U.S. Department of Energy
Through an Agreement with
National Aeronautics and Space Administration
by
Jet Propulsion Laboratory
California Institute of Technology
Pasadena, California

This work was performed for the Jet Propulsion Laboratory, California Institute of Technology, and was sponsored by the Electric Energy Systems Division of the U.S. Department of Energy through an agreement with the National Aeronautics and Space Administration.

This report was prepared as an account of work sponsored by an agency of the United States Government. Neither the United States Government nor any agency thereof, nor any of their employees, makes any warranty, express or implied, or assumes any legal liability or responsibility for the accuracy, completeness, or usefulness of any information, apparatus, product, or process disclosed, or represents that its use would not infringe privately owned rights.

Reference herein to any specific commercial product, process, or service by trade name, trademark, manufacturer, or otherwise, does not necessarily constitute or imply its endorsement, recommendation, or favoring by the United States Government or any agency thereof. The views and opinions of authors expressed herein do not necessarily state or reflect those of the United States Government or any agency thereof.

ABSTRACT

In a series of tests performed under Department of Energy auspices, power line carrier propagation was observed to be anomalous under certain circumstances. To investigate the cause, a distribution system simulator was constructed. The simulator was a physical simulator that accurately represented the distribution system from below power frequency to above 50 kHz. Effects such as phase-to-phase coupling and skin effect were modeled.

Construction details of the simulator, and experimental results from its use are given in this report.

FOREWORD

In 1976 the Energy Research and Development Administration (ERDA), now the U.S. Department of Energy (DOE) was supporting the concept of load management (using a number of systems to communicate between control centers and control points) for energy conservation in utility distribution systems. Several methods were considered to satisfy communication requirements for load management: Power Line Carrier (PLC), ripple, radio, and telephone.

While the approaches were far from new, the technology as applied to load management in the utility distribution systems was relatively immature. To alleviate this situation, several projects were supported by industry. To contribute to the technology of PLC and ripple, two research projects were sponsored by ERDA:

- (1) Radio Frequency (RF) Model of the Distribution System as a Communication Channel, (referred to in this report as the RF Model).
- (2) A Noise Analysis of the Distribution System.

To encourage industry to enter the market and to get experience with the characteristics of the various systems, ERDA and the Electric Power Research Institute (EPRI) entered into a jointly sponsored program, Demonstrations of Communication Systems for Distribution Automation. These demonstrations consisted of the following systems and sponsors:

- (1) PLC systems:
 - (a) EPRI/Detroit Edison/Westinghouse.
 - (b) EPRI/Carolina Power and Light (CP&L)/Compuguard.
 - (c) ERDA(DOE)/Oak Ridge National Laboratory(ORNL)/
San Diego Gas and Electric (SDG&E)/American Science and
Engineering (AS&E).
- (2) Radio systems: EPRI/Long Island Lighting Co. (LILCO)/Westinghouse.
- (3) Telephone systems: ERDA(DOE)/ORNL/Omaha Public Power District/
Metropolitan Utilities District/Darco.

These Programs ran more or less concurrently.

Certain aspects of the PLC systems contributed to the need for a Distribution System Simulator. Early in the course of the demonstrations, problems in the

performance of all of the PLC systems were encountered. For the communication aspects of the problems, these were probably caused by the following factors:

- (1) Immature extension to the distribution system of transmission line PLC technology, urge to enter the market quickly before the competition.
- (2) Development on small distribution systems and subsequent application to large distribution systems.
- (3) Extreme changes in line impedance and the need for line preparation.
- (4) Lack of understanding of injection techniques.
- (5) Higher than expected line noise.
- (6) Poor implementation
- (7) Low carrier powers.
- (8) Frequency selection.
- (9) Failures.

The simulator described in this report was developed as part of the work of the Communications and Control Project at the Jet Propulsion Laboratory, primarily through the efforts of the then Project Manager, Carl Gilchrist. Its purpose was to provide a better understanding of the exact nature of the problems experienced with the PLC systems. To provide verifiable results, the simulator was designed to model a section of the distribution system of the SDG E Company. Flexibility was provided so that the effect of changing parameters could be ascertained.

This report, based largely on the work of Carl Gilchrist, describes the design and construction of the Power System Simulator and discusses some of the results obtained from it. One of the authors, S. Rahman, is at Virginia Polytechnic Institute and State University.

CONTENTS

INTRODUCTION AND BACKGROUND.	1-1
Background	1-1
Simulation by Digital Computer	1-1
Analog versus Digital Simulation	1-3
Simulator Constructed	1-3
Feeder Topology.	1-7
Overhead Line Configuration.	1-7
MATHEMATICS OF TRANSFORMER SCALING	2-1
Introduction and Purpose	2-1
Scaling.	2-1
Summary.	2-6
HARDWARE DESCRIPTION	3-1
Substation Simulator	3-1
Feeder Simulator	3-1
Other Hardware	3-4
SAN DIEGO GAS AND ELECTRIC STUDY	4-1
Introduction and Purpose	4-1
Analysis	4-1
Laboratory Verification Tests.	4-10
Field Measurements	4-13
Conclusions.	4-15
SUMMARY AND CONCLUSIONS.	5-1

FIGURES

1-1.	Distribution System Simulator.	1-4
1-2.	Close-up of Feeder Simulator Simulating a Radial Distribution System	1-5
3-1.	Schematic of the Substation Simulator.	3-2
3-2.	Primary Phase-to-Ground Current Injection on Phase A.	3-4
3-3.	Schematic of Feeder Simulator Showing Various Sections	3-5
3-4.	Layout of Each Unit in a Unit Pair	3-6
4-1.	Substation Bus Load Admittances	4-2
4-2.	Primary Phase-to-Ground Current Injection Method on Phase 1	4-7
4-3.	Primary Phase-to-Phase Current Injection Method on Phases 1 and 2	4-7

TABLES

2-1.	Summary of Values and Scaled Values for the SDG&E Murray Substation Transformers	2-5
3-1.	Values for the SDG&E Murray Substation Transformers.	3-3
3-2.	Feeder Simulator Section Characteristics	3-7
4-1.	Summary of Analysis.	4-11
4-2.	Summary of Calculations and Laboratory Verification	4-12
4-3.	Murray Substation North PLC Bus Voltage Measurements Made by AS&E (Reformatted to Correspond to Tables 4-1 and 4-2).	4-13

SECTION I

INTRODUCTION AND BACKGROUND

Background

Because Power Line Carrier (PLC) systems use equipment which is wholly owned by the Electric Utility, they have been viewed favorably for distribution system communications. PLC systems suffer from the disadvantage that the communications channel is primarily a power transmission system and not a communications medium. The principal problem encountered because of this is noise: the electric power system itself or rather the loads on the power system, during normal operation, generate a considerable amount of noise.

Conventional methods of reducing the impact of power system noise on PLC communications systems include reducing the data rate and increasing the injected power. Both of these approaches were used in a series of demonstrations performed under Energy Research and Development Agency (ERDA) and Department of Energy (DOE) auspices in the late 1970s.

In spite of this, problems were experienced with the PLC systems at a number of the locations in these demonstrations. The problems were such that communications were breaking down over power line distances, which should, in principle at least, have been achievable.

Simulation by Digital Computer

It was difficult to determine the exact cause of the problems in the field. Generally speaking, field tests have the following disadvantages:

- (1) Isolation of cause and effect is difficult to achieve.
- (2) Parameters are time-variant.
- (3) Field crews are expensive, and safety is a problem.
- (4) Field tests are weather dependent.
- (5) The accuracy of field tests is difficult to maintain.

Simulation provides a more convenient means of investigation. A number of different simulation methods were used to address the PLC problem.

One of the fundamental tools developed to aid in the solution of some of these problems was a sophisticated computer radio frequency (RF) model of the distribution system. The RF model is capable of analyzing the impedances and signal levels of the distribution system and of obtaining the resulting signal levels at any point in the distribution network. This model, called the RF Model of the Distribution System as a Communication Channel, was developed under contract with the General Electric Company (GE) Research Center in Schenectady, New York.

While this computer model was a useful tool in analyzing the distribution networks for PLC propagation, it was not readily accepted by the utilities for various reasons:

- (1) Detailed data that were frequently difficult to accumulate were required to exercise the computer program. Collection of the data required a different style of labor than utility distribution engineers were accustomed to supplying. When the time and cost of analyzing all distribution networks were considered, the distribution engineers were overwhelmed.
- (2) The computer model involved a complicated program that required a considerable amount of expertise to operate and keep current. Operator training was expensive and had to be kept current to be effective. If the contract was not continuous, operators and programmers drifted to other work and were not available if modifications were required.
- (3) The computer model was developed around one specific computing system that was not universally available. Transportability to other computers and reverification would have been expensive.
- (4) There was one essential proprietary subprogram in the computer model that was not generally available to other companies.
- (5) The computer program was time consuming to modify if something new were required of it.
- (6) GE, a company involved in sales of PLC systems, did not show interest in providing the computer service to other manufacturers. GE had, however, provided the service to utilities.

The RF Model was verified by GE on the Niagara Mohawk Power Co., Schenectady, New York, and proved to be useful up to 50 kHz. A great deal of confidence in the ability to calculate signal levels, etc., has been achieved. Good correspondence with measured values has also been achieved.

Problems were encountered in getting PLC communications through certain feeders of the Murray Substation of the San Diego Gas and Electric Co. (SDG&E) for the ERDA/(DOE)/ORNL/SDG&E/AS&E system. Signals were almost zero near one specific feeder junction. The computer model at Schenectady, New York, was exercised from the Jet Propulsion Laboratory (JPL), Pasadena, California, by telephone line. Data representing the SDG&E system were used. With this simulation, the problem at the junction was determined to be caused by a lateral that had a short section of overhead wire feeding a long section of underground wire. The overhead wire was highly inductive, and the underground wire was highly capacitive at the operating frequency. These components were series resonant, which caused an impedance transformation that resulted in a very low impedance at the junction. From this analysis, a modification was devised. Power factor correction capacitors and inductors were installed, which essentially formed a parallel resonant circuit with the offending underground cable. Subsequent communications tests with this modification were successful.

Analog versus Digital Simulation

Some of the disadvantages of field tests have already been stated. There is also the question of analog versus digital simulation. Some characteristics of analog and digital simulation include the following:

Analog Simulation Characteristics:

- (1) Analog simulators model the power system component by component. As a result, there is physical correspondence between the real and modelled systems.
- (2) Superposition of effects applies. (This especially applies to assembly of harmonics for certain tasks.)
- (3) Results are almost real time.
- (4) Noise propagation studies are easier.
- (5) Quick reconfiguration is possible. (This depends on the hardware design.)
- (6) Ordinary instrumentation is available. Safety is not a problem.
- (7) To construct a simulator, it is necessary to have mathematical relationships describing each component.

Digital Simulation Characteristics:

- (1) Processing is generally more accurate.
- (2) In addition to requiring a model of each component, as in (7) above, it is necessary to have mathematical relationships describing the entire system. This aspect is accomplished by hardware interconnections in an analog simulator.
- (3) Programming knowledge is required. Expensive training is required.
- (4) Changes in output/input are more difficult.

Simulator Constructed

The Distribution System Simulator consists of two analog simulators: a substation and a feeder simulator (Figures 1-1 and 1-2).

Substation Simulator

During the testing on the three-phase PLC system installed at SDG&E, currents were injected in six possible ways. (There are three phase-to-phase and three phase-to-ground possibilities.) The resulting voltages on the feeder buses were difficult to explain. JPL undertook the tasks of performing a mathematical analysis of the circuit and of assembling a substation analog to

ORIGINAL PAGE IS
OF POOR QUALITY

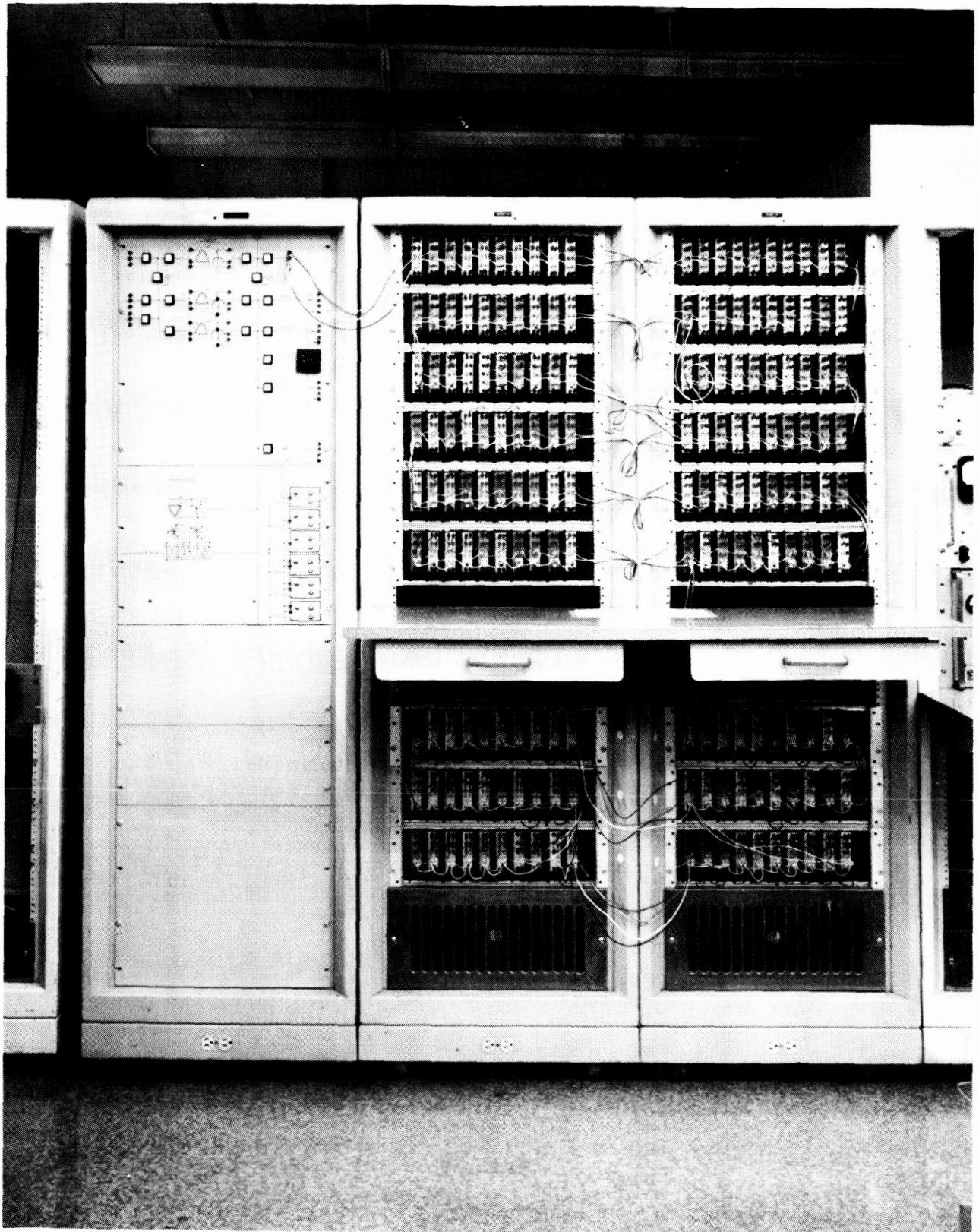

Figure 1-1. Distribution System Simulator

ORIGINAL PAGE IS
OF POOR QUALITY

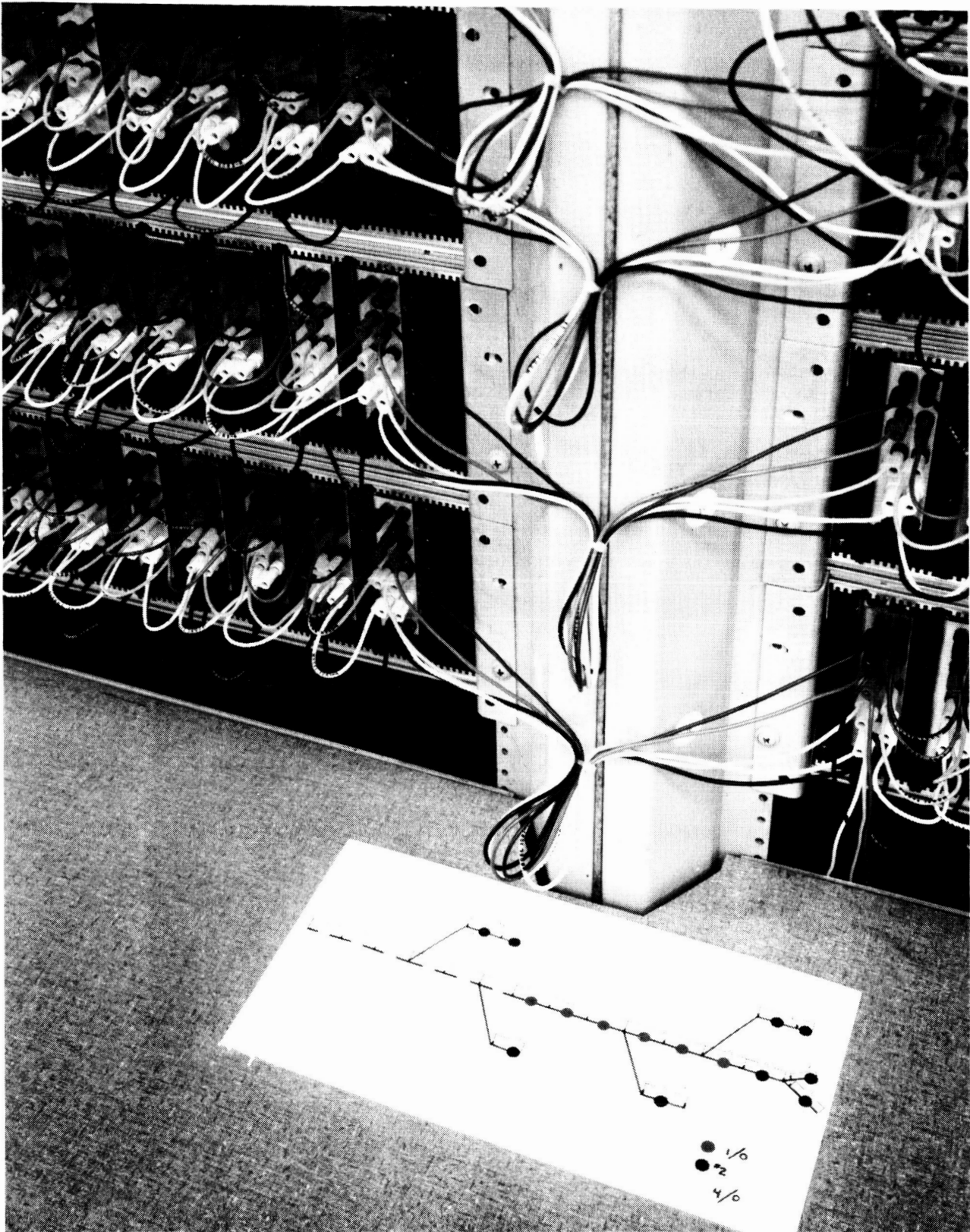

Figure 1-2. Close-up of Feeder Simulator Simulating a Radial Distribution System

verify the analysis. The results of the tasks were in correspondence with one another and were successful in explaining the measured results at SDG&E.

The substation simulator was also used to check out other ideas, one of which was the design of a directional coupler capable of rejecting noise coming into the substation from different feeders. Theoretically, this circuit is capable of approximately 10-dB improvement in communications in a substation with 9 to 11 feeders. Bench checks were completed on parts of the system. The complete simulator ran into problems in scaling the drives from current transformers that modeled the substation switchgear. Tests are still incomplete.

Feeder Simulator

The feeder simulator was considered as an alternate to augment the capabilities of the digital simulator. In addition to the reasons listed above for advantages of the analog simulator over the digital simulator for PLC systems, it was also decided that the analog feeder simulator would be useful in the following studies:

- (1) Harmonic propagation studies of Dispersed Storage and Generation (DSGs) and similar hardware.
- (2) Stability studies of installed DSGs.
- (3) Transient network analysis (distribution system fusing studies, etc.).

The following goals were established for the design of an analog feeder simulator:

- (1) Cover a frequency range of 60 to 50,000 Hz without changing parameter values.
- (2) Simulate skin effect on wire resistance and inductance.
- (3) Simulate ground impedance.
- (4) Create a flexible design that can be easily changed to accommodate topology and parameter changes.
- (5) Create a design that has easy physical access to circuit points.
- (6) Place simulated line hardware within the equivalent of one-half city block of the true position of a real selected feeder.
- (7) Account for all interconductor inductances and capacitances.

The feeder simulator was successfully constructed. All design goals, with one exception, were met. The exception was that the performance of the simulator at extreme high frequency might not be the same as the distribution system.

The frequency response of the interconductor inductance simulation and skin effect simulation was measured, as well as the impulse response of the feeder simulator. The remainder of the tests, including PLC propagation, noise propagation, load effects, etc., were not completed.

Feeder Topology

It was the original intention to simulate SDG&E's Circuit 85 from their Murray Substation in El Cajon, California, because PLC communication problems had been experienced on this circuit, and because considerable field tests and computer simulation had been accomplished to determine their cause. Circuit 85 was an excellent location for conducting any DSG experiment. Before the simulator could be completed, SDG&E decommissioned the PLC trials and showed little interest in DSG for the future. However, Circuit 85 was used as a guide in setting the simulator topology.

The simulator uses discrete elements to simulate the distributed parameters of a multiconductor feeder. The section lengths to be simulated were selected on the basis of how closely transformers and other hardware would be located. It was decided that these sections should be about one city block (or about 100 m). These 100-m sections could be assembled into almost any topology. Provisions were also made for changing of conductor sizes of #0000, #0, #2, #4, and #6 solid round copper wire. A feeder of 8000 m in simulated length was subsequently constructed.

Overhead Line Configuration

The overhead line configuration selected for simulation had three-phase wires and a neutral wire on a single cross arm. The wire spacing was 3 ft on centers and 42 ft above ground. This configuration was typical of the express feeder on Circuit 85 at SDG&E's Murray Substation but not necessarily typical of the entire feeder. Conductors on other cross arms were not considered. The wide spacings give small interconductor capacitance and large interconductor inductance, and give a slightly more extreme value of components for the simulator design.

SECTION II

MATHEMATICS OF TRANSFORMER SCALING

Introduction and Purpose

The purpose of this section is to describe the transformer scaling used for a partial simulation of the DOE/ORNL/SDG&E/AS&E demonstration. The term scaling means that the value of some system parameter is changed, such as frequency, voltage, current, impedance, etc., so that simulation can be accomplished at greater convenience (for example, smaller size, faster, less power, or greater/smaller frequency).

It is inconvenient to duplicate the distribution system transformers (substation and distribution transformers) in the laboratory because of their size and size-related cost. The size is dictated by the power-handling capability of the transformers, and is not related to its communication system performance except with regard to how the power-handling capability determines the impedance parameters of the transformer. It is the interplay of the system impedances that affects the communication system performance, and not 60-Hz power levels. Although impedances can readily be scaled, it would seem desirable not to scale impedances (and frequencies) so that results could be interpreted without rescaling.

Scaling

Because the communication system voltages are many times smaller than the 60-Hz power, and because it is not necessary to operate with 60-Hz excitation, the 60-Hz operating voltage can be easily scaled while holding the impedances constant, with a significant transformer size reduction. The voltage scaling can be much larger than the ratio of the power frequencies voltage to communication voltage because the communication frequency is usually 100 times the power frequency. Thus, the operating flux of the transformer is much less at the communication frequency. The scaling suggested here, then, is to hold the impedances constant and to scale the 60-Hz voltage appropriately.

There are two kinds of transformers that need to be scaled for simulation of the distribution network for PLC studies, especially for the distribution network at SDG&E. These are the substation transformers and the injection/distribution transformers.

The substation transformers at SDG&E Murray Substation are three-phase, 69-kV Δ -connected to 6.9-kV Y-connected transformers with a capacity of 15 MVA (for open-air operation), 20 MVA (for forced-air operation), and 25 to 28 MVA (for short term operation). The rating for the purpose of impedance calculations will be taken as the open-air rating. The injection transformers used at the same substation are of two types:

- (1) Three each, single-phase 7200 V to 120/240 V, 25 kVA with $Z_s = 1.88\%$
- (2) Three each, single-phase 12000 V to 120/240 V, 25 kVA with $Z_s = 1.88\%$

They are used for phase-to-ground and phase-to-phase excitation, respectively, for the communication signals.

For the three-phase (3 ϕ) substation transformer, the rated load impedance for each phase is

$$Z_{L\phi} = \frac{V_{\phi}^2}{\frac{S}{3}} = \frac{3 V_{\phi}^2}{S} \quad (1)$$

where

$Z_{L\phi}$ = load impedance for each phase

V_{ϕ} = voltage for each phase

S = substation transformer rating

Assume scaling of the voltage so that

$$V_{\phi} = a V_{s\phi} \quad (2)$$

where

a = the scaling factor (similar to a turns ratio)

$V_{s\phi}$ = the scaled phase voltage. Now

$$V_{\phi} I_{\phi} = \frac{S}{3} \quad (3)$$

where I_{ϕ} is the phase current and also

$$V_{\phi} I_{\phi} = \frac{V_{\phi}^2}{Z_{L\phi}} \quad (4)$$

where $Z_{L\phi}$ is fixed by assumption.

Using Equation (2) in Equation (4)

$$V_{\phi} I_{\phi} = \frac{a^2 V_{s\phi}^2}{Z_{L\phi}} \quad (5)$$

Because $Z_{L\phi}$ is fixed by assumption, $I_{s\phi}$ is proportional to $V_{s\phi}$ by the relation

$$I_{s\phi} = \frac{V_{s\phi}}{Z_{L\phi}} \quad (6)$$

where $I_{s\phi}$ is the scaled phase current.

Therefore, Equation (5) becomes

$$V_{s\phi} I_{s\phi} = \frac{a^2 V_{s\phi}^2}{Z_{L\phi}} = \frac{a^2 V_{s\phi}^2}{\frac{V_{s\phi}}{I_{s\phi}}} = a^2 V_{s\phi} I_{s\phi} \quad (7)$$

Because the total rating is equal to the number of phases times the phase rating, Equation (7) can be interpreted as either

$$(\text{actual rating})_{\phi} = a^2 (\text{scaled rating})_{\phi} \quad (8)$$

or

$$(\text{actual rating})_{TOT} = a^2 (\text{scaled rating})_{TOT} \quad (9)$$

As an example calculation of Equation (9), assume that the 6.9-kV secondary voltage of the 15-MVA substation transformer is scaled down to 69 V. Then

$$a = \frac{6.9 \text{ kV}}{69 \text{ V}} = 100 \quad (10)$$

Using Equation (9), then

$$\begin{aligned} (V_s I_s)_{TOT} &= \left(\frac{1}{100}\right)^2 (15 \text{ MVA})_{TOT} \\ &= 1.5 \text{ kVA} \end{aligned} \quad (11)$$

Assume the transformer is scaled according to the above example. The question is: What are the remaining specifications? In determining the scaled current

$$V_{s\phi} I_{s\phi} = \frac{1500}{3} \text{ VA} \quad (11a)$$

or

$$I_{s\phi} = \frac{500}{69} = 7.25 \text{ A} \quad (12)$$

Now considering the transformer impedance,

$$Z_{s\phi} = kZ_{L\phi} \quad (13)$$

where

$Z_{s\phi}$ = the transformer equivalent series impedance
(not to be confused with a scaled value)

k = a factor of proportionality (equal to 0.01 times the
nameplate value of percent impedance)

Some designers prefer to specify regulation instead of $Z_{s\phi}$, so another equation is needed.

Now multiply Equation (13) by I_ϕ , obtaining

$$I_\phi Z_{s\phi} = k I_\phi Z_{L\phi} \quad (14)$$

but

$$I_\phi Z_{L\phi} = V_\phi$$

so that

$$I_\phi Z_{s\phi} = k V_\phi \quad (15)$$

or

$$k = \frac{I_\phi Z_{s\phi}}{V_\phi} \quad (16)$$

The value, k , is now recognized as the regulation of the transformer. As already noted, k is usually obtained from the nameplate of the transformer. For distribution transformers, it is about 2%. Table 2-1 summarizes the values for the transformers used at Murray Substation as well as the scaled values.

Small transformers usually have a $Z_{s\phi}$ that is primarily resistive, while larger transformers have a significant leakage inductance component as well. In larger transformers, the windings have a split design to hold the leakage inductance to reasonable values. For the small scaled transformers described above, the impedance is then resistive, which may require that inductances be added externally to simulate the actual transformer impedance. This is easily done, but the transformer must be sufficiently large to hold the resistive component down. The transformer probably should be designed for a 1% resistance component and have a 1% value of inductance added externally.

Internal capacitance does not scale conveniently with size of the transformer. For small transformers, the capacitance is smaller than that of the full-scale transformer. If needed, compensating capacitors can be added for simulation purposes.

Table 2-1. Summary of Values and Scaled Values
for the SDG&E Murray Substation Transformers

Parameter	Transformer		
	Substation	Y- Δ Injection	Y-Y Injection
Rating, S	15 MVA	25 kVA	25 kVA
Number of Phases	3	1	1
V_{ϕ} (primary)	69 kV	12 kV	7.2 kV
V_{ϕ} (secondary)	6.9 kV	120/240 V	120/240 V
Turns ratio	10:1	100:1	60:1
$Z_{L\phi}$	9.52 (secondary) ohms	5760 (primary) ohms	2073 (primary) ohms
Regulation k (assumed for design)	1%	1%	1%
$Z_{s\phi}$	0.095 ohms (referred to secondary)	57.6 ohms (referred to primary)	20.7 ohms (referred to primary)
Scaling factor (Scaled rating) _{TOT}	100 1.5 kVA	100 2.5 VA	100 2.5 VA
$V_{s\phi}$ (primary)	690 V	120 V	72 V
$V_{s\phi}$ (secondary)	69 V	1.2 V	1.2 V
$I_{s\phi}$ (primary)	0.725 A	0.021 A	0.035 A
$I_{s\phi}$ (secondary)	7.25 A	2.1 A	2.1 A

The core loss is proportional to the core volume and for the scaled transformer is many times less than for the full-scale transformer. But even at full scale, it is only a small percentage of the load, and it can be considered as part of the load.

Summary

If a transformer is scaled in both voltage and current, and if the regulation is the same as the unscaled transformer, the series impedance of the scaled transformer is the same as that of the unscaled transformer. Stated another way, a three-phase 1.5-kVA, 69-V secondary Y connected/690-V primary, Δ connected, 1% regulation transformer will have about the same series impedance $Z_{s\phi}$ as a three-phase 15-MVA, 6.9-kV secondary, Y connected/69-kV primary, Δ connected, 1% regulation transformer. Inductance and capacitance are added externally to compensate for the fact that these parameters do not scale conveniently.

SECTION III

HARDWARE DESCRIPTION

Substation Simulator

The substation simulator contains three distribution transformers (each simulating a 15-MVA unit), a total of six injection transformers for the purpose of injecting the PLC signal, a number of relays, and a power supply for the relays. A schematic of the substation simulator is shown in Figure 3-1. Table 3-1 also illustrates the values and scaled values of the SDG&E Murray Substation transformer.

A signal generator is used to inject the signal into the primary side of the injection transformer. The substation simulator is designed to accommodate the six different signal injection possibilities (three phase-to-phase and three phase-to-ground choices). An additional transformer with a turns ratio of 100:1 may be required between the signal generator and the primary side of the injection transformer. The output of any injection transformer may be connected to the distribution line simulator line-to-line, line-to-neutral, or in any desired fashion. Figure 3-2 shows a phase-to-ground current injection method on Phase A.

The substation simulator may also be used to check out other ideas. One such idea is the design of a directional coupler that is capable of rejecting noise coming into the substation from different feeders. Theoretically, this circuit can result in an approximately 10-dB improvement in communications in a substation with 9 to 11 feeders.

Feeder Simulator

The feeder simulator has a panel containing 18 sections. Each section is labeled by a number, but the numbers are not necessarily in order. Figure 3-3 shows the configuration of the feeder simulator. Distribution lines are simulated in 100-m segments. Each segment requires two components that are called 'unit pairs'. With the exception of Section 23, which contains only 4-unit pairs, an individual section contains 5-unit pairs. The first unit of each unit pair simulates the series resistance and inductance of the distribution line as a function of frequency. It also simulates the ground wire. The second unit simulates the mutual inductance between lines (the three-phase lines and the neutral lines). The layout of each unit is shown in Figure 3-4. Various unit pairs represent different conductor sizes. The color circle in Figure 3-4 may be yellow, blue, or green, indicating the wire size of #0000, #0, or #2 solid round copper wire, respectively. Table 3-2 lists the characteristics of the feeder simulator sections.

It should be noted that each unit pair is configured to simulate a distribution line in which:

- (1) All the three-phase lines and the neutral line are located in a horizontal plane.

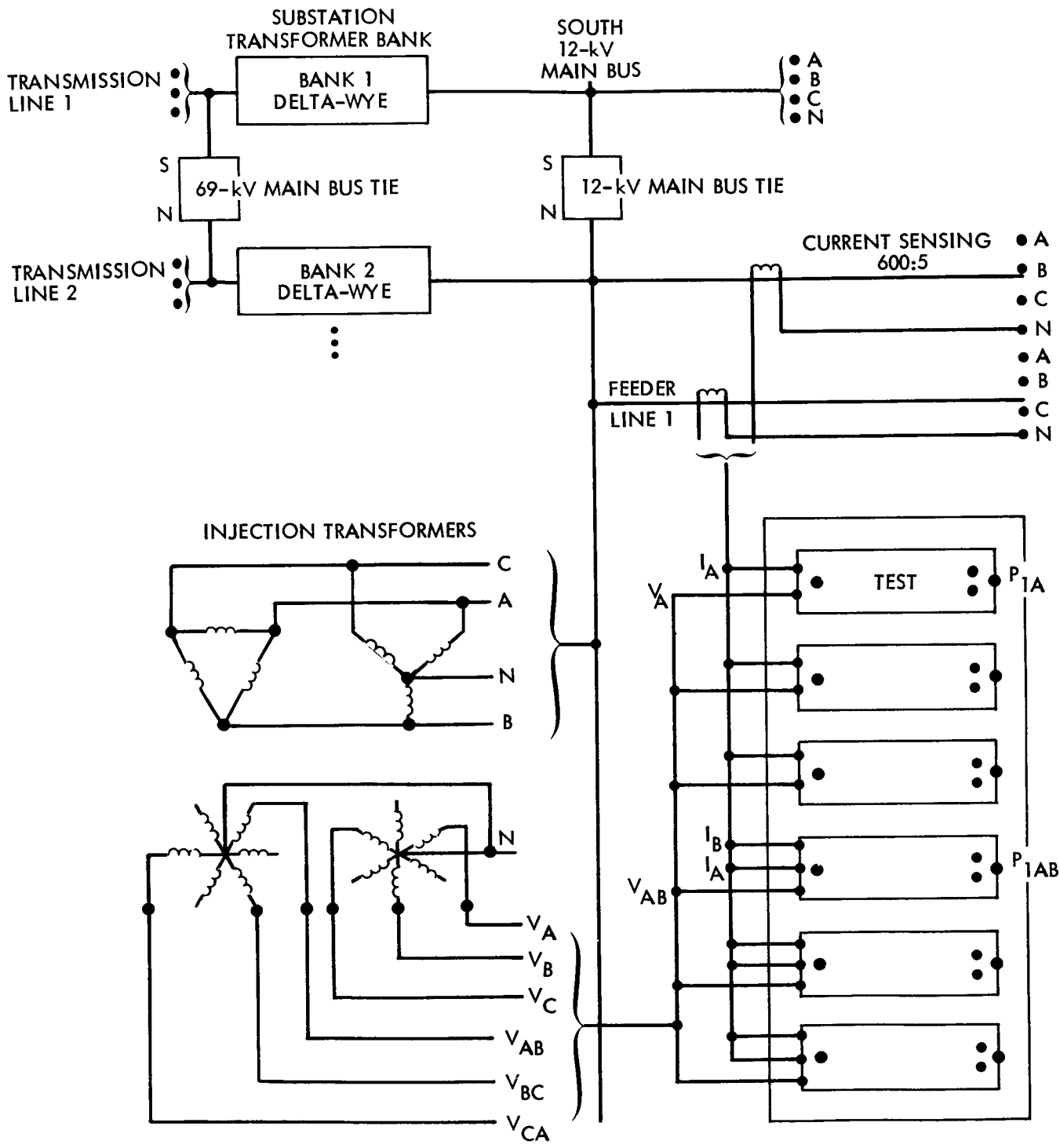

Figure 3-1. Schematic of the Substation Simulator

Table 3-1. Values for the SDG&E Murray Substation Transformers

Parameter	Transformers		
	Substation	Y- Δ Injection	Y-Y Injection
Number of Phases	3	1	1
V_{ϕ} (primary)	69 kV	12 kV	7.2 kV
V_{ϕ} (secondary)	6.9 kV	120/240 V	120/240 V
Turns ratio	10:1	100:1	60:1
$Z_{L\phi}$, ohms	9.52 (secondary)	5760 (primary)	2073 (primary)
$Z_{s\phi}$, ohms	0.095 (secondary)	57.6 (primary)	20.7 (primary)
Scaling factor	100	100	100
Scaled rating	1.5 kVA	2.5 VA	2.5 VA
$V_{s\phi}$ (primary)	690 V	120 V	72 V
$V_{s\phi}$ (secondary)	69 V	1.2 V	1.2 V
$I_{s\phi}$ (primary)	0.725 A	0.021 A	0.035 A
$I_{s\phi}$ (secondary)	7.25 A	2.1 A	2.1 A

V_{ϕ} = phase voltage
 $Z_{L\phi}$ = load impedance for each phase
 $Z_{s\phi}$ = transformer equivalent series impedance
 $V_{s\phi}$ = scaled phase voltage
 $I_{s\phi}$ = scaled phase current

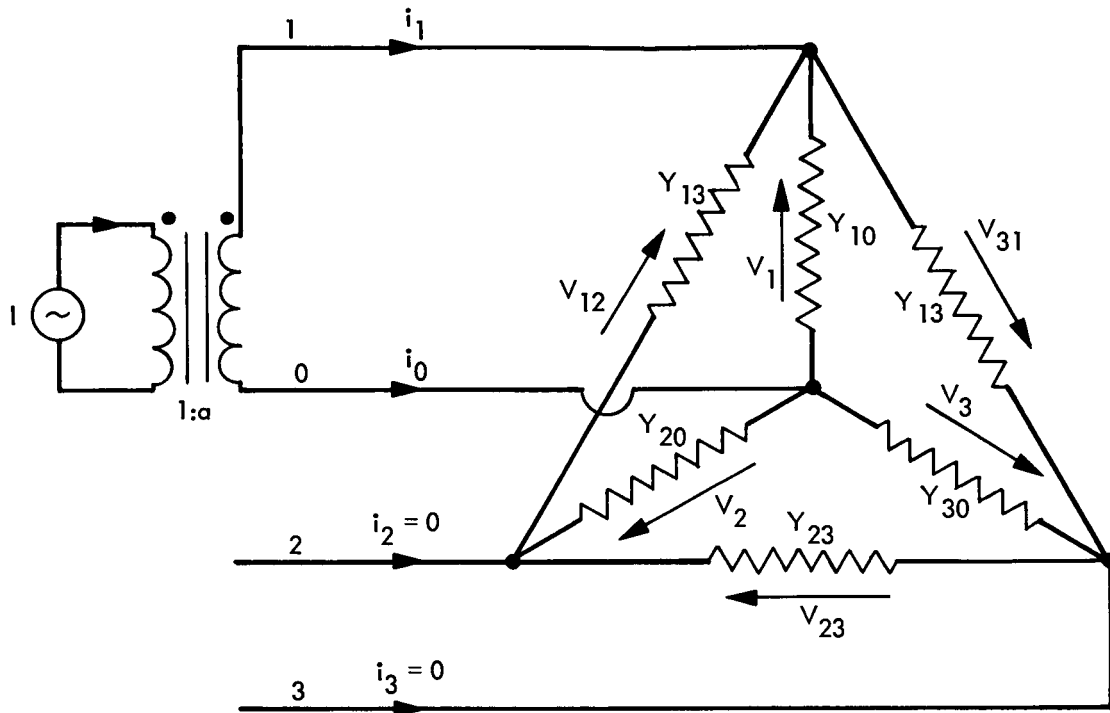

Figure 3-2. Primary Phase-to-Ground Current Injection on Phase A

- (2) The ordering of the layout is Phase A, Phase B, Phase C, and neutral.
- (3) The distance between wires is 3.0 ft.
- (4) The height of the distribution pole is 30 to 35 ft.

The scaling factor between the distribution line and the units is unity, i.e., the impedances are directly repeated. There are 89 unit pairs. With all of the units connected in series, a 8900-m distribution system can be simulated.

Other Hardware

In addition to the substation and feeder simulators, function generators, oscilloscopes, and other equipment may be required.

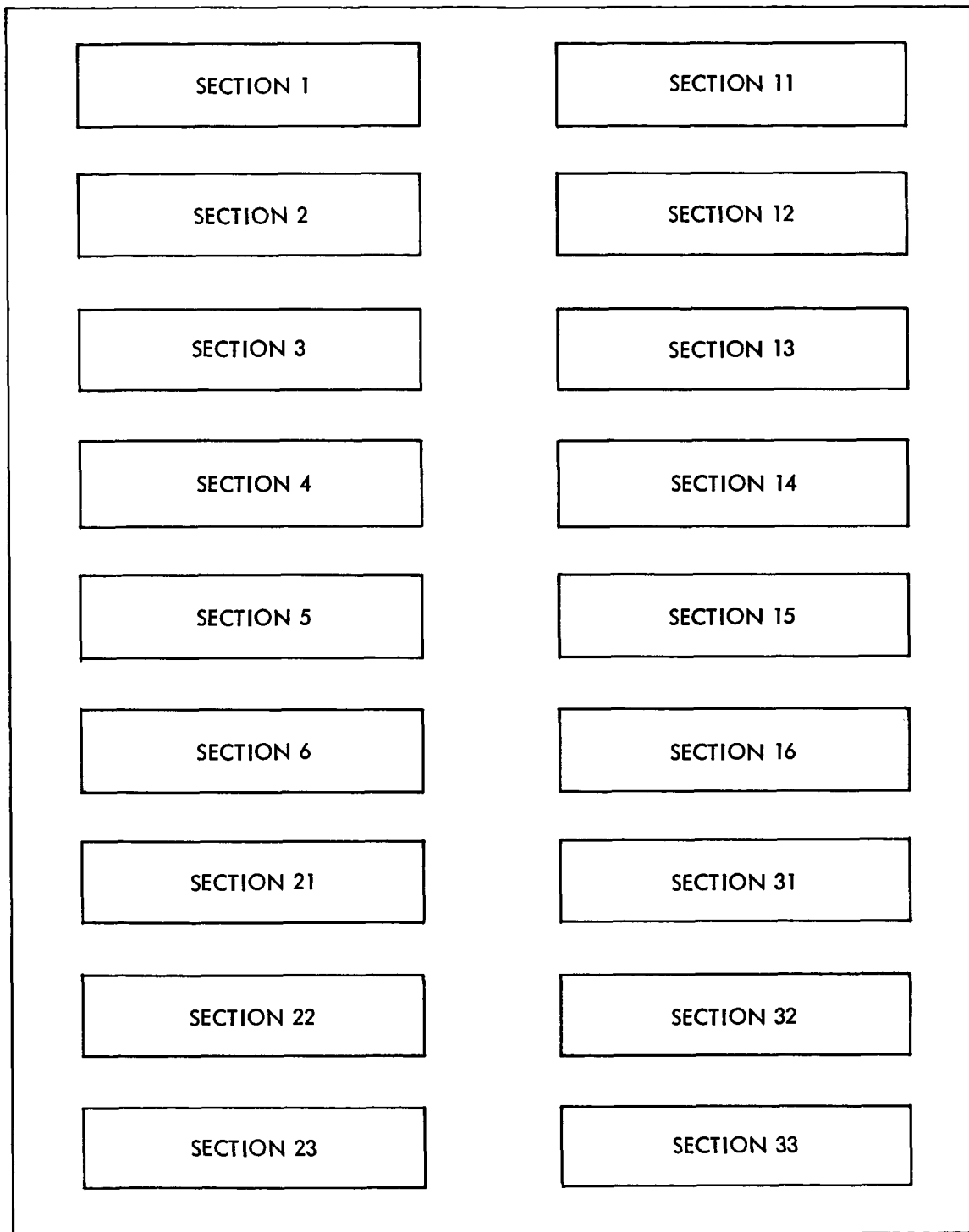

Figure 3-3. Schematic of Feeder Simulator Showing Various Sections

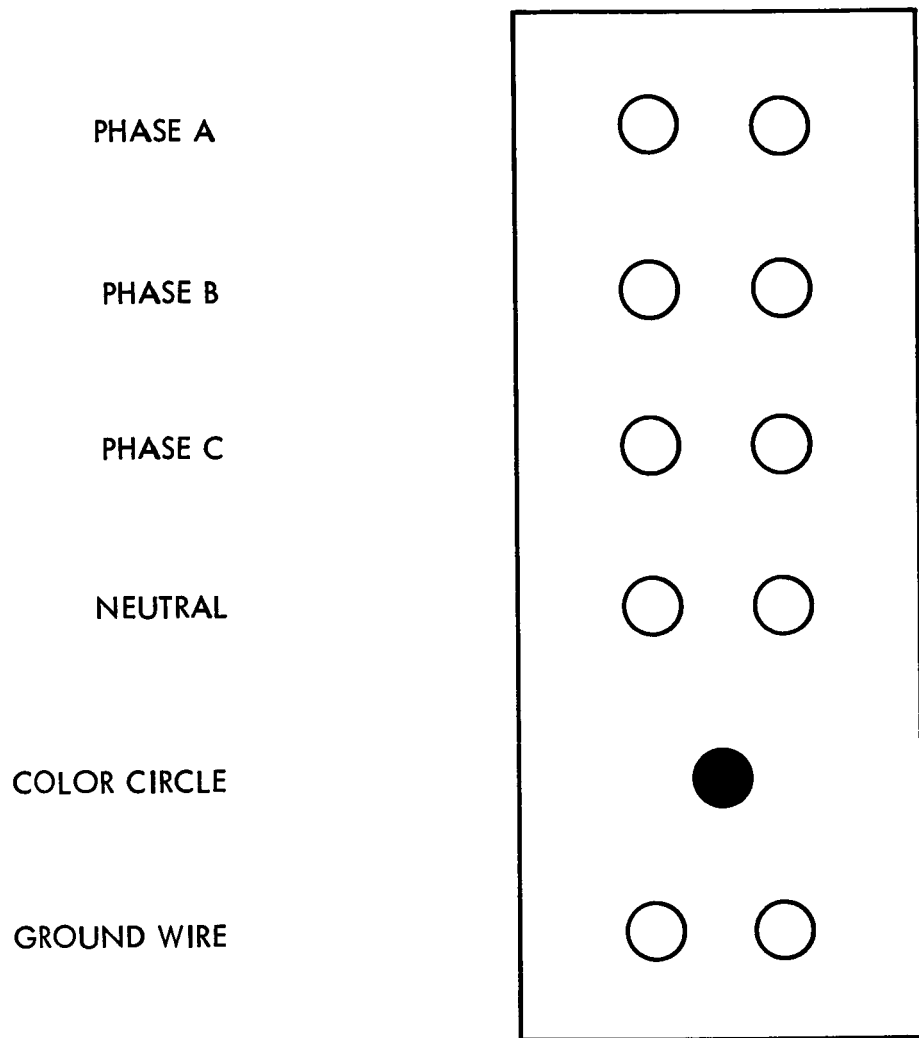

Figure 3-4. Layout of Each Unit in a Unit Pair

Table 3-2. Feeder Simulator Section Characteristics

Section	Number of Pairs Contained	Code Color	Wire Size Simulated
1	5	Yellow	#0000
2	5	Green	#2
3	5	Green	#2
4	5	Yellow	#0000
5	5	Blue	#0
6	5	Green	#2
11	5	Yellow	#0000
12	5	Yellow	#0000
13	5	Yellow	#0000
14	5	Yellow	#0000
15	5	Blue	#0
16	5	Blue	#0
21	5	Blue	#0
22	5	Green	#2
23	4	Green	#2
31	5	Blue	#0
32	5	Blue	#0
33	5	Green	#2

SECTION IV

SAN DIEGO GAS AND ELECTRIC STUDY

Introduction and Purpose

The SDG&E Murray and El Cajon Substations and distribution systems were selected as the sites for a demonstration, in part, to study performance of a PLC system on a distribution system of a type that no previous measurements (experience) had been obtained.

The Murray and El Cajon Substations and distribution systems were different from previous sites of PLC system installations where test data were available. At these sites there were significant numbers of both phase-to-phase (for overhead lines) and phase-to-ground (for underground lines) connected loads. A PLC signal injection system was devised to accommodate the six different signal injection possibilities (three phase-to-phase and three phase-to-ground choices).

In August and October, 1979, verification and trouble-shooting tests were performed by American Science and Engineering (AS&E) at SDG&E. These tests left a number of unanswered questions, which JPL became active in answering. Part of that activity was to explain an unexpectedly large cross-coupling of voltages on the various substation bus phases for the injection choices. The simulator constructed by JPL was used to provide insight into this problem. Tests with this simulator pointed to the type of load (Y or Δ) as a large contributor to this cross-coupling.

This section reports on the analyses of the injection system installed at SDG&E and compares it to laboratory and field tests. Close correspondence between analysis and tests was obtained. The results show that strong cross-coupling between several bus voltages should be expected.

Analysis

Preliminary tests on a laboratory simulator of the Murray Substation indicated that the voltages on the substation bus because of currents injected into signal injection transformers are sensitive to the makeup of the load admittances. The assumption is, therefore, that the admittances are made up of Y and Δ admittances as shown in Figure 4-1.

In general the relationship between currents and voltages in a three-phase system can be represented by an admittance matrix as follows:

$$\begin{bmatrix} i_1 \\ i_2 \\ i_3 \end{bmatrix} = \begin{bmatrix} Y_{11} & Y_{12} & Y_{13} \\ Y_{21} & Y_{22} & Y_{23} \\ Y_{31} & Y_{32} & Y_{33} \end{bmatrix} \begin{bmatrix} V_1 \\ V_2 \\ V_3 \end{bmatrix} \quad (17)$$

The immediate problem is to solve for the Y_{ij} , $i = 1, 2, 3$, and $j = 1, 2, 3$, in Equation (17) in terms of the admittances shown in of Figure 4-1. This is

done by setting the two voltages equal to zero and solving for i_1 , i_2 , and i_3 , such as:

$$\begin{bmatrix} i_1 \\ i_2 \\ i_3 \end{bmatrix} = \begin{bmatrix} Y_{11} & Y_{12} & Y_{13} \\ Y_{21} & Y_{22} & Y_{23} \\ Y_{31} & Y_{32} & Y_{33} \end{bmatrix} \begin{bmatrix} V_1 \\ 0 \\ 0 \end{bmatrix} \quad (18)$$

that yields

$$\begin{bmatrix} \frac{i_1}{V_1} \\ \frac{i_2}{V_1} \\ \frac{i_3}{V_1} \end{bmatrix} = \begin{bmatrix} Y_{11} \\ Y_{21} \\ Y_{31} \end{bmatrix} = \begin{bmatrix} Y_{10} + Y_{12} + Y_{13} \\ -Y_{12} \\ -Y_{13} \end{bmatrix} \quad (19)$$

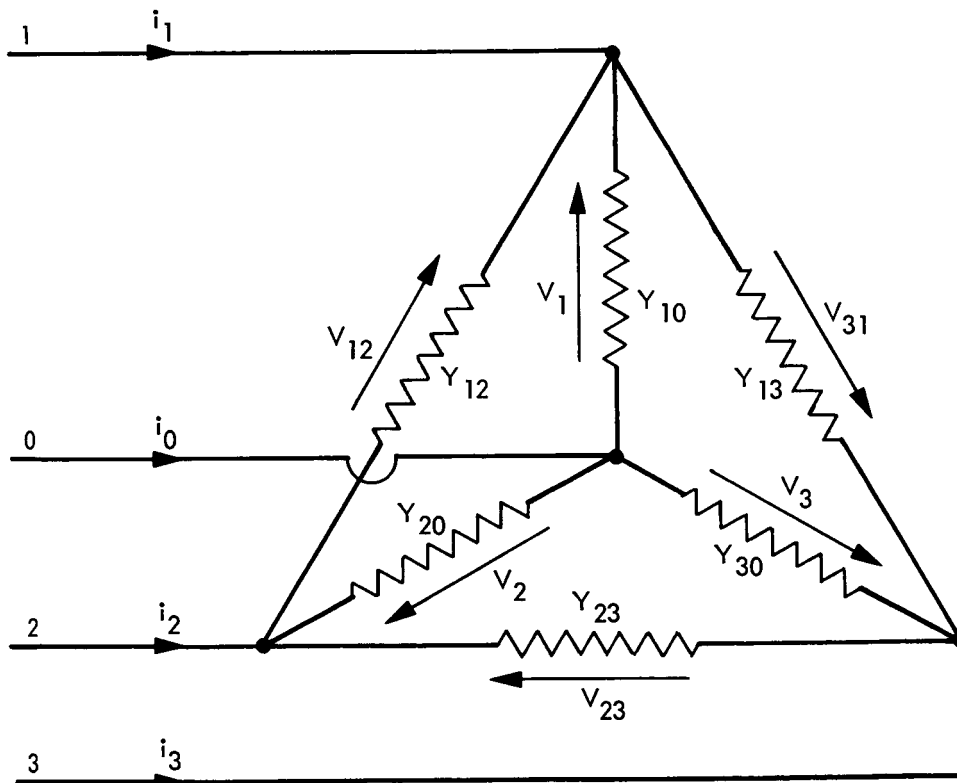

Figure 4-1. Substation Bus Load Admittances

Successive permutations of the indices for setting the voltages equal to zero result in:

$$\begin{bmatrix} i_1 \\ i_2 \\ i_3 \end{bmatrix} = \begin{bmatrix} Y_{10} + Y_{12} + Y_{13} & -Y_{12} & -Y_{13} \\ -Y_{12} & Y_{20} + Y_{12} + Y_{23} & -Y_{23} \\ -Y_{13} & -Y_{23} & Y_{30} + Y_{13} + Y_{23} \end{bmatrix} \begin{bmatrix} V_1 \\ V_2 \\ V_3 \end{bmatrix} \quad (20)$$

It is reasonable to assume that the substation bus load is balanced, making

$$Y_{10} = Y_{20} = Y_{30} = Y_Y \quad (21)$$

and

$$Y_{12} = Y_{23} = Y_{31} = Y_\Delta \quad (22)$$

Matrix (20) now becomes

$$\begin{bmatrix} i_1 \\ i_2 \\ i_3 \end{bmatrix} = \begin{bmatrix} Y_Y + 2Y_\Delta & -Y_\Delta & -Y_\Delta \\ -Y_\Delta & Y_Y + 2Y_\Delta & -Y_\Delta \\ -Y_\Delta & -Y_\Delta & Y_Y + 2Y_\Delta \end{bmatrix} \begin{bmatrix} V_1 \\ V_2 \\ V_3 \end{bmatrix} \quad (23)$$

Further assume that the total connected substation load is

$$\text{total substation load} = S \quad (24)$$

Let

$$k = \frac{Y \text{ load}}{\text{total load}} \quad \text{where } 0 \leq k \leq 1 \quad (25)$$

therefore,

$$Y \text{ load} = S k \quad (26)$$

$$\Delta \text{ load} = S (1 - k) \quad (27)$$

or

$$\text{total substation load} = S = S k + S (1 - k) \quad (28)$$

Using the assumption that the loads are balanced, the load admittance magnitudes can be calculated as follows:

$$Y_Y = \frac{\frac{S_k}{3}}{\left(\frac{V}{\sqrt{3}}\right)^2} = \frac{S}{V^2} k \quad (29)$$

and

$$Y_\Delta = \frac{\frac{S}{3}}{V^2} (1 - k) = \frac{S}{3V^2} (1 - k) \quad (30)$$

where V is the 60-Hz, line-to-line voltage.

Substituting Equations (29) and (30) in (23) yields the following matrix:

$$\begin{bmatrix} i_1 \\ i_2 \\ i_3 \end{bmatrix} = \begin{bmatrix} \frac{S k}{V^2} + \frac{2S(1-k)}{3V^2} & -\frac{S(1-k)}{3V^2} & -\frac{S(1-k)}{3V^2} \\ -\frac{S(1-k)}{3V^2} & \frac{S k}{V^2} + \frac{2S(1-k)}{3V^2} & -\frac{S(1-k)}{3V^2} \\ -\frac{S(1-k)}{3V^2} & -\frac{S(1-k)}{3V^2} & \frac{S k}{V^2} + \frac{2S(1-k)}{3V^2} \end{bmatrix} \begin{bmatrix} V_1 \\ V_2 \\ V_3 \end{bmatrix} \quad (31)$$

Collecting terms, Matrix (31) becomes:

$$\begin{bmatrix} i_1 \\ i_2 \\ i_3 \end{bmatrix} = \frac{S}{3V^2} \begin{bmatrix} k+2 & k-1 & k-1 \\ k-1 & k+2 & k-1 \\ k-1 & k-1 & k+2 \end{bmatrix} \begin{bmatrix} V_1 \\ V_2 \\ V_3 \end{bmatrix} \quad (32)$$

Matrix (32) is not in the right form because it is the solution of [I] when it is the [V] that is needed. Matrix (32) must be inverted or

$$\begin{bmatrix} V_1 \\ V_2 \\ V_3 \end{bmatrix} = \frac{3V^2}{S} \begin{bmatrix} k+2 & k-1 & k-1 \\ k-1 & k+2 & k-1 \\ k-1 & k-1 & k+2 \end{bmatrix}^{-1} \begin{bmatrix} i_1 \\ i_2 \\ i_3 \end{bmatrix} \quad (33)$$

Simplify Equation (33) by making the following substitutions:

$$\alpha = k + 2 \quad (34)$$

and

$$\beta = k - 1 \quad (35)$$

Equation (33) becomes

$$\begin{bmatrix} V_1 \\ V_2 \\ V_3 \end{bmatrix} = \frac{3V^2}{S} \begin{bmatrix} \alpha & \beta & \beta \\ \beta & \alpha & \beta \\ \beta & \beta & \alpha \end{bmatrix}^{-1} \begin{bmatrix} i_1 \\ i_2 \\ i_3 \end{bmatrix} \quad (36)$$

Using Cramer's Rule for the matrix inversion yields:

$$\begin{aligned} |\text{Det}| &= (\alpha^3 + 3\beta^3) - (3\alpha\beta^2) = \alpha^3 - 3\alpha\beta^2 + 2\beta^3 \\ &= (\alpha - \beta)(\alpha^2 + \alpha\beta - 2\beta^2) = (\alpha - \beta)^2(\alpha + 2\beta) \end{aligned}$$

and

$$\begin{bmatrix} V_1 \\ V_2 \\ V_3 \end{bmatrix} = \frac{3V^2}{S} \frac{1}{(\alpha - \beta)^2(\alpha + 2\beta)} \begin{bmatrix} \alpha^2 - \beta^2 & -(\alpha\beta - \beta^2) & -(\alpha\beta - \beta^2) \\ -(\alpha\beta - \beta^2) & \alpha^2 - \beta^2 & -(\alpha\beta - \beta^2) \\ -(\alpha\beta - \beta^2) & -(\alpha\beta - \beta^2) & \alpha^2 - \beta^2 \end{bmatrix} \begin{bmatrix} i_1 \\ i_2 \\ i_3 \end{bmatrix} \quad (37)$$

Factoring:

$$\alpha^2 - \beta^2 = (\alpha + \beta)(\alpha - \beta)$$

and

$$\alpha\beta - \beta^2 = \beta(\alpha - \beta)$$

Equation (37)

$$\begin{bmatrix} V_1 \\ V_2 \\ V_3 \end{bmatrix} = \frac{3V^2}{S} \frac{1}{(\alpha - \beta)(\alpha + 2\beta)} \begin{bmatrix} \alpha + \beta & -\beta & -\beta \\ -\beta & \alpha + \beta & -\beta \\ -\beta & -\beta & \alpha + \beta \end{bmatrix} \begin{bmatrix} i_1 \\ i_2 \\ i_3 \end{bmatrix} \quad (38)$$

Using Equations (34) and (35) for the terms involving α and β ,

$$\begin{aligned}(\alpha - \beta) &= k + 2 - k + 1 = 3 \\(\alpha + \beta) &= k + 2 + k - 1 = 2k + 1 \\(\alpha - 2\beta) &= k + 2 + 2k - 2 = 3k\end{aligned}$$

then Equation (38) becomes

$$\begin{bmatrix} v_1 \\ v_2 \\ v_3 \end{bmatrix} = \frac{V^2}{3kS} \begin{bmatrix} 1 + 2k & 1 - k & 1 - k \\ 1 - k & 1 + 2k & 1 - k \\ 1 - k & 1 - k & 1 - 2k \end{bmatrix} \begin{bmatrix} i_1 \\ i_2 \\ i_3 \end{bmatrix} \quad (39)$$

In setting up the problem, a choice is available to write the original Equation (17) as either

$$[I] = [Y][V]$$

or

$$[V] = [Z][I]$$

The latter is the form of Equation (39).

The Z_{ij} for $i = 1, 3$, and $j = 1, 3$, values are more difficult to obtain than the Y_{ij} , for $i = 1, 3$, and $j = 1, 3$, but the Y_{ij} requires the matrix inversion. Both methods lead to the same result with about the same amount of algebraic manipulation.

Now, assume a current of I amperes is injected in the low side of the injection transformers (with a current source) as shown in Figures 4-2 and 4-3. The turns ratios for the injection methods indicated in Figures 4-2 and 4-3 are

$$a = \frac{\frac{12,000}{\sqrt{3}}}{120 \text{ V}} = \frac{100}{\sqrt{3}} \quad (40)$$

corresponding to the phase-to-ground injection method and

$$a' = \frac{12,000}{120} = 100 \quad (41)$$

corresponding to the phase-to-phase injection method.

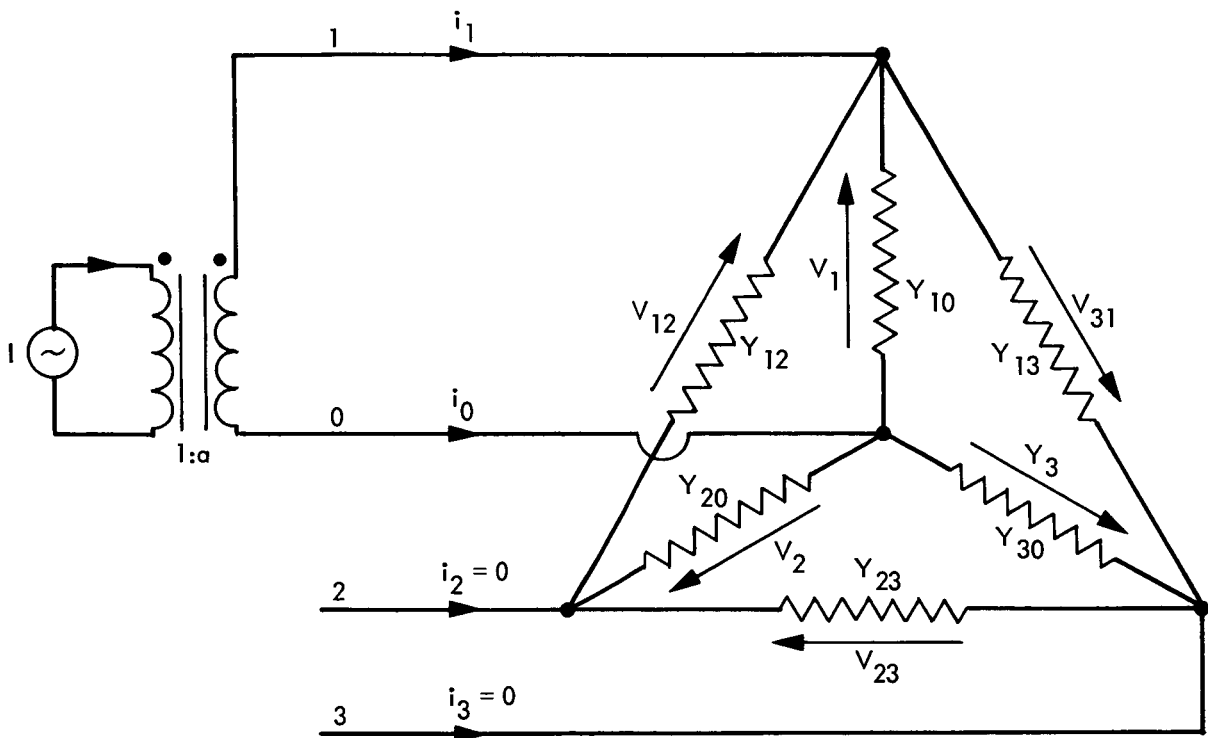

Figure 4-2. Primary Phase-to-Ground Current Injection Method on Phase 1

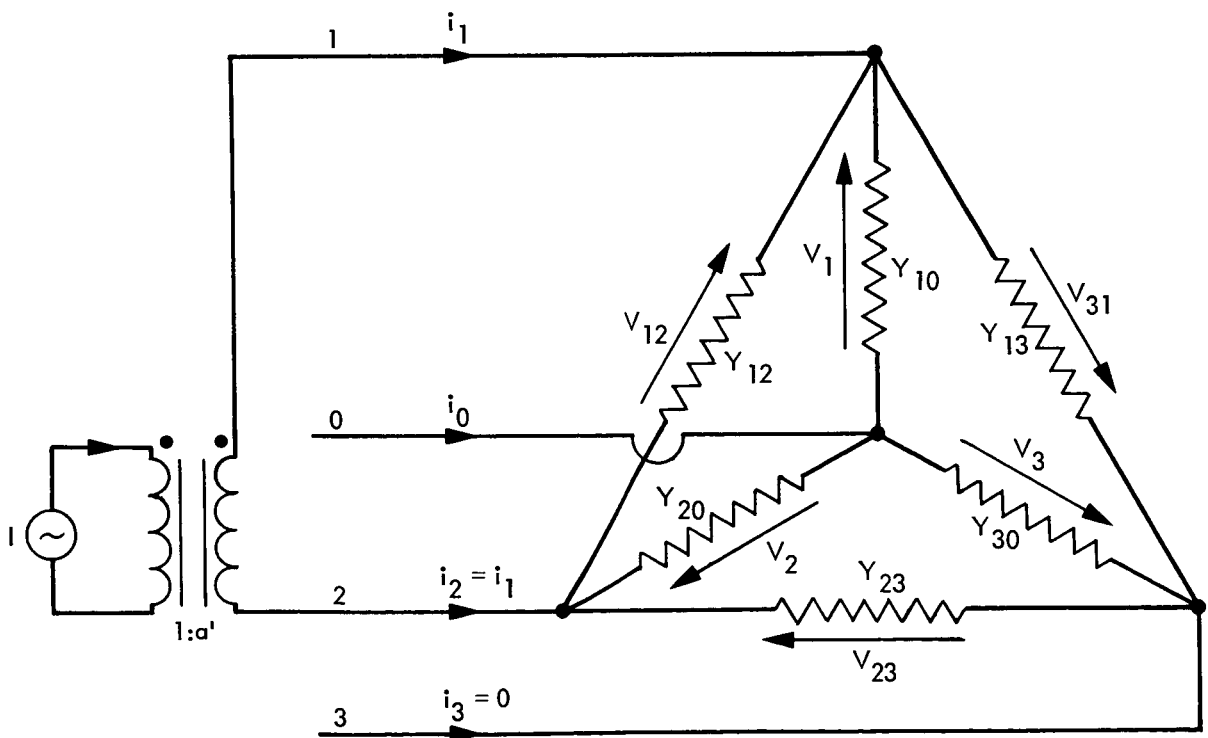

Figure 4-3. Primary Phase-to-Phase Current Injection Method on Phases 1 and 2

Then

$$i_1 = \frac{I\sqrt{3}}{100}, \quad i_2 = 0, \quad \text{and} \quad i_3 = 0 \quad (42)$$

for the phase-to-ground injection method on Phase 1 and

$$i_1 = \frac{I}{100}, \quad i_2 = -i_1 = \frac{-I}{100}, \quad \text{and} \quad i_3 = 0 \quad (43)$$

for the phase-to-phase injection method on Phases 1 and 2. Equation (39) becomes

$$\begin{bmatrix} V_1 \\ V_2 \\ V_3 \end{bmatrix} = \frac{V^2}{S} \frac{1}{3k} \begin{bmatrix} 1 + 2k & 1 - k & 1 - k \\ 1 - k & 1 + 2k & 1 - k \\ 1 - k & 1 - k & 1 - 2k \end{bmatrix} \begin{bmatrix} \frac{I\sqrt{3}}{100} \\ 0 \\ 0 \end{bmatrix} \quad (44)$$

or

$$\begin{bmatrix} V_1 \\ V_2 \\ V_3 \end{bmatrix} = \frac{V^2}{S} \frac{I\sqrt{3}}{300k} \begin{bmatrix} 1 + 2k \\ 1 - k \\ 1 - k \end{bmatrix} \quad (45)$$

for the phase-to-ground injection system on Phase 1, and

$$\begin{bmatrix} V_1 \\ V_2 \\ V_3 \end{bmatrix} = \frac{V^2}{S} \frac{1}{3k} \begin{bmatrix} 1 + 2k & 1 - k & 1 - k \\ 1 - k & 1 + 2k & 1 - k \\ 1 - k & 1 - k & 1 + 2k \end{bmatrix} \begin{bmatrix} \frac{I}{100} \\ -\frac{I}{100} \\ 0 \end{bmatrix} \quad (46)$$

or

$$\begin{bmatrix} V_1 \\ V_2 \\ V_3 \end{bmatrix} = \frac{V^2 I}{S 100} \begin{bmatrix} 1 \\ -1 \\ 0 \end{bmatrix} \quad (47)$$

for the phase-to-phase injection system on Phases 1 and 2.

Equations (45) and (47) give the phase-to-ground voltages for the injection methods stated. Two other sets of voltages are of interest: the phase-to-phase voltages for the two injection methods (phase-to-ground and phase-to-phase). To calculate these (see Figure 4-1), note that

$$V_{12} = V_1 - V_2 \quad (48)$$

$$V_{23} = V_2 - V_3 \quad (49)$$

$$V_{31} = V_3 - V_1 \quad (50)$$

Therefore,

$$\begin{bmatrix} V_{12} \\ V_{23} \\ V_{31} \end{bmatrix} = \frac{V^2}{S} \frac{1}{3k} \begin{bmatrix} (1+2k) - (1-k) & (1-k) - (1+2k) & (1-k) - (1-k) \\ (1-k) - (1-k) & (1+2k) - (1-k) & (1-k) - (1+2k) \\ (1-k) - (1+2k) & (1-k) - (1-k) & (1+2k) - (1-k) \end{bmatrix} \begin{bmatrix} i_1 \\ i_2 \\ i_3 \end{bmatrix} \quad (51)$$

or

$$\begin{bmatrix} V_{12} \\ V_{23} \\ V_{31} \end{bmatrix} = \frac{V^2}{S} \begin{bmatrix} 1 & -1 & 0 \\ 0 & 1 & -1 \\ -1 & 0 & 1 \end{bmatrix} \begin{bmatrix} i_1 \\ i_2 \\ i_3 \end{bmatrix} \quad (52)$$

Using Equations (42) in Equation (52) to calculate the phase-to-phase voltages for phase-to-ground injection current into Phase 1 yields the following:

$$\begin{bmatrix} V_{12} \\ V_{23} \\ V_{31} \end{bmatrix} = \frac{V^2}{S} \begin{bmatrix} 1 & -1 & 0 \\ 0 & 1 & -1 \\ -1 & 0 & 1 \end{bmatrix} \begin{bmatrix} \frac{I\sqrt{3}}{100} \\ 0 \\ 0 \end{bmatrix} \quad (53)$$

$$= \frac{V^2}{S} \frac{I\sqrt{3}}{100} \begin{bmatrix} 1 \\ 0 \\ -1 \end{bmatrix} \quad (54)$$

Similarly, using Equation (43) in Equation (52) to calculate the phase-to-phase voltages for phase-to-phase injection current into Phases 1 and 2 yields the following:

$$\begin{bmatrix} V_{12} \\ V_{23} \\ V_{31} \end{bmatrix} = \frac{V^2}{S} \begin{bmatrix} 1 & -1 & 0 \\ 0 & 1 & -1 \\ -1 & 0 & 1 \end{bmatrix} \begin{bmatrix} \frac{I}{100} \\ -\frac{I}{100} \\ 0 \end{bmatrix} \quad (55)$$

$$= \frac{V^2}{S} \frac{I}{100} \begin{bmatrix} 2 \\ -1 \\ -1 \end{bmatrix} \quad (56)$$

A summary of Equations (45), (47), (54), and (56) is shown in Table 4-1.

Equations (45) and (56) show strong cross coupling terms. Equation (45) shows that the phase-to-ground voltage can go to infinity for $k = 0$. This is because the injection current has no finite impedance return path. All the voltages can be put into perspective if the appropriate voltage divider action of the network is inspected closely.

Laboratory Verification Tests

Tests were performed on the substation simulator for all modes of excitation, five k factors, and all modes of signal extraction. The assumptions for the tests were:

$$I = 1.0 \text{ A} \quad (\text{Injection current on secondary})$$

$$S = 30 \text{ MVA} \quad (\text{Equal to capacity of two 15-MVA transformers in parallel})$$

$$V = 12,000 \text{ V}$$

Results of the calculations and measurements are shown in Table 4-2. Correspondence between calculations and measurements are generally very good except where $k = 0$. In the setup, k could not actually be equal to zero because half the injection transformers were connected in Y and were present during the test.

Table 4-1. Summary of Analysis

Bus Voltage	Phase-to-Ground Current Injection on Phase 1 ^a	Phase-to-Phase Current Injection on Phases 1 and 2 ^a
	Equation (45)	Equation (47)
Phase-to-ground voltage	$\begin{bmatrix} v_1 \\ v_2 \\ v_3 \end{bmatrix} = \frac{v^2}{S} \frac{I\sqrt{3}}{300k} \begin{bmatrix} 1 + 2k \\ 1 - k \\ 1 - k \end{bmatrix}$	$\begin{bmatrix} v_1 \\ v_2 \\ v_3 \end{bmatrix} = \frac{v^2}{S} \frac{I}{100} \begin{bmatrix} 1 \\ -1 \\ 0 \end{bmatrix}$
	Equation (54)	Equation (56)
Phase-to-phase voltage	$\begin{bmatrix} v_{12} \\ v_{23} \\ v_{31} \end{bmatrix} = \frac{v^2}{S} \frac{I\sqrt{3}}{100} \begin{bmatrix} 1 \\ 0 \\ -1 \end{bmatrix}$	$\begin{bmatrix} v_{12} \\ v_{23} \\ v_{31} \end{bmatrix} = \frac{v^2}{S} \frac{I}{100} \begin{bmatrix} 2 \\ -1 \\ -1 \end{bmatrix}$
<p>^a To get the resulting voltages for other injection phases, permute the appropriate indices.</p>		

Table 4-2. Summary of Calculations and Laboratory Verification

Voltages	Phase-to-Ground Current Injection on Phase 1		Phase-to-Phase Current Injection on Phases 1 and 2				
<u>Phase-to-Ground Voltages</u>							
		Calculated	Measured ^a	Calculated	Measured ^a		
k = 1 (Same as all Y load)	$\begin{bmatrix} V_1 \\ V_2 \\ V_3 \end{bmatrix}$	$\begin{bmatrix} 0.0831 \\ 0 \\ 0 \end{bmatrix}$	$\begin{bmatrix} 0.0785 \\ 0.0008 \\ 0.0008 \end{bmatrix}$	$\begin{bmatrix} 0.0480 \\ -0.0480 \\ 0.0 \end{bmatrix}$	$\begin{bmatrix} 0.0480 \\ 0.0478 \\ 0.0005 \end{bmatrix}$		
	k = 0.8	$\begin{bmatrix} V_1 \\ V_2 \\ V_3 \end{bmatrix}$	$\begin{bmatrix} 0.090 \\ 0.0069 \\ 0.0069 \end{bmatrix}$	$\begin{bmatrix} 0.0903 \\ 0.0073 \\ 0.0069 \end{bmatrix}$			
		k = 0.6	$\begin{bmatrix} V_1 \\ V_2 \\ V_3 \end{bmatrix}$	$\begin{bmatrix} 0.1016 \\ 0.0185 \\ 0.0185 \end{bmatrix}$	$\begin{bmatrix} 0.1000 \\ 0.0178 \\ 0.0172 \end{bmatrix}$		
			k = 0.2	$\begin{bmatrix} V_1 \\ V_2 \\ V_3 \end{bmatrix}$	$\begin{bmatrix} 0.1939 \\ 0.1108 \\ 0.1108 \end{bmatrix}$	$\begin{bmatrix} 0.182 \\ 0.101 \\ 0.101 \end{bmatrix}$	
	k = 0.0 (Same as all Δ load)	$\begin{bmatrix} V_1 \\ V_2 \\ V_3 \end{bmatrix}$		$\begin{bmatrix} \\ \\ \end{bmatrix}$	$\begin{bmatrix} 1.88 \\ 1.84 \\ 1.84 \end{bmatrix}$		
<u>Phase-to-Phase Voltages</u>							
	$\begin{bmatrix} V_{12} \\ V_{23} \\ V_{31} \end{bmatrix}$	$\begin{bmatrix} 0.0831 \\ 0.0 \\ -0.0831 \end{bmatrix}$	$\begin{bmatrix} 0.0842 \\ 0.0015 \\ 0.0820 \end{bmatrix}$	$\begin{bmatrix} 0.0980 \\ -0.0480 \\ -0.0480 \end{bmatrix}$	$\begin{bmatrix} 0.0964 \\ 0.0483 \\ 0.0481 \end{bmatrix}$		
^a Signs were not noted in the tests.							

Field Measurements

Measurements on the SDG&E Murray Substation North Bus through capacitor couplers are shown in Table 4-3. There is a correspondence between these measurements and the equations summarized in Table 4-2.

Table 4-3. Murray Substation North PLC Bus Voltage Measurements Made by AS&E (Reformatted to Correspond to Tables 4-1 and 4-2)

	Phase-to-Ground Current Injection, 10 A			Phase-to-Phase Current Injection, 10 A		
	A-G	B-G	C-G	A-B	B-C	C-A
Phase-to-ground, ^a						
A-G	3.68	1.28	1.29	1.41	0.77	1.41
B-G	1.6	4	1.89	1.68	0.98	0.22
C-G	1.6	1.76	4.21	0.48	1.68	1.17
Phase-to-phase, ^a						
A-B		No		2.96	0.85	1.12
B-C		measurements		1.18	2.48	1.31
C-A		available		1.76	1.60	2.4
^a Polarity of voltage measurements is not available from the test data. Data are in volts.						

The derivation of the equations in this report assumes that the impedances were balanced. However, the actual bus impedances may not be balanced. As a result, some variation between the measurements and calculations can be anticipated. Also, because the load on the substation or the ratio of the Y load to the total load (k) is unknown, the expected voltages cannot be predicted with precision. Nevertheless, one can work backward from the data to calculate these voltages to determine if they are reasonable and consistent.

The diagonal terms of the first 9 numbers of Table 4-3 (3.68, 4, and 4.21) should correspond to (1 + 2k) of Equation (45) (see Table 4-1), and the off-diagonal terms should correspond to (1 - k) of Equation (45). If the diagonal and the off-diagonal terms are averaged (to remove the effects of unbalanced loads) and the ratio taken, then:

$$\frac{(1 + 2k)}{(1 - k)} = \frac{\langle \text{diagonal terms} \rangle}{\langle \text{off-diagonal terms} \rangle} = \frac{3.96}{1.57}$$

where < > means 'average'

Solving for k:

$$k = 0.33$$

The value $k = 0.33$ is a reasonable value for the amount of underground (Y-connected load) to overhead (A-connected load) lines on the Murray Substation. This measured value of k is at the signalling frequency and may not fully reflect the value of k at 60 Hz. Using the value $k = 0.33$, one can calculate the substation load through either the $(1 - k)$ or the $(1 + 2k)$ term of Equation (45). If the value of $(1 - k)$ is used, then

$$\langle \text{off-diagonal terms} \rangle = 1.57 = \frac{V^2}{S} \frac{I\sqrt{3}}{300} \frac{1 - k}{k}$$

then

$$S = \frac{V^2}{1.57} \frac{I\sqrt{3}}{300} \frac{1 - k}{k}$$

whereas

$$I = 10 \text{ A}$$

then

$$S = 10.75 \text{ MVA}$$

This value is about a third of the OA (oil-immersed, self-cooled), 60-Hz rating of the parallel transformer banks [Equations (48) and (49)] installed in the SDG&E Murray Substation North Bus and seems to be a reasonable value for operation at the signalling frequency.

The 9 numbers in the upper right quadrant of Table 4-3, corresponding to Equation (47) from the analysis, show a sizable departure from what is expected. There should be at least three entries that are closer to zero than the data show. (These are those corresponding to V_{CG} for phases A-B current injection, V_{AG} for phases B-C, and V_{BG} for phases C-A.) This specific measurement is sensitive to the unbalances of the load. However, if the rest of the data corresponding to Equation (47) are averaged, the bus load can be calculated to determine if it is consistent with the calculation of the preceding paragraph, then

$$\langle 1.41, 1.41, 1.68, 0.98, 1.68, 1.17 \rangle = 1.39 = \frac{V^2}{S} \frac{I}{100}$$

or

$$S = \frac{V^2}{1.31} \frac{I}{100} = 10.36 \text{ MVA}$$

that is consistent with the previous value calculated.

The data of the lower right quadrant of Table 4-3, corresponding Equation (56), indicate that the diagonal terms should be twice the off-diagonal terms. If these terms are averaged to remove the effects of the load unbalance, then:

$$\frac{\langle \text{diagonal terms} \rangle}{\langle \text{off-diagonal terms} \rangle} = \frac{2.6133}{1.31033} = 2.005$$

Except for the unbalance there is a good correspondence between the analysis and the field measurements. The data can also be used to calculate the substation load at the injected signalling frequency by using Equation (56). Then:

$$\langle \text{off-diagonal terms} \rangle = 1.31 = \frac{V^2}{S} \frac{I}{100}$$

or

$$S = \frac{V^2}{1.31} \frac{I}{100} = 10.99 \text{ MVA}$$

that is consistent with the two previous calculations.

A summary of the substation load (at signalling frequency) calculated from the test data is:

from Equation (45) Load = 10.75 MVA

from Equation (47) Load = 10.36 MVA

from Equation (56) Load = 10.99 MVA

Conclusions

Very good correspondence was obtained between analysis, simulation results, and field test data. Therefore, a high degree of cross coupling between the bus voltages corresponding to the signal injection system should be expected at the SDG&E Murray Substation.

SECTION V

SUMMARY AND CONCLUSIONS

To improve the reliability of service and economy of operation, many utilities and some government agencies are considering the possibility of distribution automation. Load management, of the kind that has been practiced for a number of years in the United States and abroad, can be considered to be one specific subset of distribution automation. Other aspects of distribution automation would include voltage control in the distribution system, feeder reconfiguring following faults, load redistribution, and automatic meter reading.

The different aspects of distribution automation each impose an additional burden on the communication system. In spite of the low data rate usually experienced with PLC systems, they are nevertheless receiving attention again as possible communications media in the implementation of distribution automation. Newer and more ingenious uses of PLC are still being developed.

The simulator described in this report may be useful for analyzing signal propagation in distribution systems in ways as yet untried. The simulator is a detailed model of a distribution system, including the phase-to-phase and phase-to-ground effects and the skin effect of the conductors. Because of this it should be possible to use it to study single-phase and multi-phase injection over a variety of frequencies, and over a number of possible line and cable designs.

The usefulness of the simulator may continue until a different and distinctly better communications channel is implemented in the distribution system. For many utilities, such a development may be a long way in the future.