

CR-171 949

FINAL REPORT  
NASA Lyndon B. Johnson Space Flight Ctr.  
Contract NAS 9-17516  
31 Mar 1986

(NASA-CR-171949) A NEW APPROACH TO  
NON-INVASIVE OXYGENATED MIXED VENOUS  
ECC(SUB)2 Final Report (Vacumetrics, Inc.)  
79 p

N87-15682

CSCL 06E

Unclass

G3/52 40245

FINAL REPORT

31 March 1986

Contract NAS9-17516

NASA Lyndon B. Johnson Space Flight Center

CONTENTS

	<u>Page</u>
1. Scientific Review: A new approach to non-invasive oxygenated mixed venous $PCO_2$	1
2. Fisher System Users Manual	48
3. Fisher System Documented	A1-A12
Appendix A	

A NEW APPROACH TO NON-INVASIVE OXYGENATED MIXED VENOUS PCO<sub>2</sub>

Joseph A. Fisher, M.D., F.R.C.P.(C)  
Department of Anesthesia  
The Wellesley Hospital, Toronto  
Assistant Professor, Faculty of Medicine  
University of Toronto

Clifford A. Ansel  
Division of Engineering Science  
Faculty of Applied Science and Engineering  
University of Toronto

Address reprints to: Dr. J. A. Fisher, Department of Anesthesia  
Room 150, Turner Wing, Wellesley Hospital  
160 Wellesley Street, Toronto, Ontario, M4Y 1J3

### Glossary of abbreviations

C.O.	cardiac output
$\dot{V}CO_2$	amount of $CO_2$ exhaled per minute which in steady state equal to the $CO_2$ production rate
FRC	functional residual capacity
$V_D$	dead space
A	alveolar
$CaCO_2$	arterial $CO_2$ content
$CvCO_2$	mixed venous $CO_2$ content
$PaCO_2$	arterial $CO_2$ partial pressure
$P\bar{V}CO_2$	mixed venous $CO_2$ content
$F_I$	refers to fractional concentration of inspired gas
$F_E$	refers to fractional concentration of expired gas
$F_{FRC}$	fractional concentration of a gas in the FRC
	-EI subscript = end inspiratory
	-EE subscript = end expiratory
$\bar{v}$	mixed venous concentration
$D(\bar{v}-A)CO_2$	pulmonary arterial (mixed venous)-alveolar $CO_2$ concentration gradient

## Introduction

The purpose of this study was to develop a clinically practical technique to calculate mixed venous CO<sub>2</sub> partial pressure (P $\bar{V}$ CO<sub>2</sub>) for the calculation of cardiac output (C.O.) by the Fick technique.

The basis of using a Fick approach to measuring cardiac output has been extensively reviewed by Grollman (1). As it applies to CO<sub>2</sub>, the Fick principle states that the cardiac output is equal to the CO<sub>2</sub> production ( $\dot{V}$ CO<sub>2</sub>) divided by the arterio-venous CO<sub>2</sub> content difference of the pulmonary vessels (C $\bar{V}$ CO<sub>2</sub>-CaCO<sub>2</sub>). Stated in symbols,

$$CO = \frac{\dot{V}CO_2}{C\bar{V}CO_2 - CaCO_2}$$

where C $\bar{V}$ CO<sub>2</sub> is the CO<sub>2</sub> content of blood in mixed venous blood entering the lungs and CaCO<sub>2</sub> is the CO<sub>2</sub> content of arterial blood. Of these,  $\dot{V}$ CO<sub>2</sub> can be measured by analyzing a time collection of expired gas for CO<sub>2</sub>. The CaCO<sub>2</sub> can be calculated from arterial partial pressure for CO<sub>2</sub> (PaCO<sub>2</sub>). This in turn can be calculated noninvasively from end tidal gases (2) or relatively easily from an arterial puncture. It is the difficulties inherent in the noninvasive estimation of (P $\bar{V}$ CO<sub>2</sub>) that have been the impediment to widespread application of the technique.

A review of the principles involved in the various techniques used to estimate P $\bar{V}$ CO<sub>2</sub> (for C $\bar{V}$ CO<sub>2</sub> calculation) is presented by Richards and Strauss (3). They classify these techniques as attempts to "use the lungs as an aerotonometer, in an attempt to bring the lung gases into equilibrium with inflowing venous (pulmonary artery) blood

before recirculation alters the character of this inflowing blood". These, as well as the more recent techniques depend on data gathered after certain subject manoeuvres.

1) Breath holding techniques

- a) In one method as used by Dubois et al (4, 19) the subjects held their breath for variable periods of time then exhaled and a sample of end tidal gas was analyzed. The mixed venous  $PCO_2$  was derived from extrapolation of the end tidal  $PCO_2$  values to an asymptote at infinite time or by calculating when the amount of  $CO_2$  added to the lung was equal to 0 (16).
- b) Frankel et al (5) had their subjects take a breath to vital capacity of gas containing either 100%  $O_2$  or 12%  $CO_2$  in  $O_2$ . They held their breath and exhaled 500 ml at 5 seconds and then again at 15 sec. Assuming the exponential approach of alveolar  $PCO_2$  to  $P\bar{V}CO_2$ , the  $P\bar{V}CO_2$  was calculated by extrapolating to the same  $PCO_2$  value from above and below.

2) Rebreathing techniques

- i) Defares (6) had subjects rebreath from a closed container and samples were analyzed after each exhalation. The  $PCO_2$  rose steadily in an exponential manner towards an asymptote ( $P\bar{V}CO_2$ ) which was mathematically and graphically calculated.
- ii) Collier (7), and later McEvoy et al (2) and Powles (8) described a technique where the subjects rebreath from a bag containing an amount of  $CO_2$  designed to allow the system to equilibrate at the mixed venous  $CO_2$  tension.

These techniques have been shown to predict mixed venous  $PCO_2$  extremely well in clinical situations such as patients under

general anaesthesia (9), or patients suffering from congestive heart failure (10), severe respiratory disease (11), with hypercapnea (12) and other severe diseases requiring intensive care (13, 14). Yet despite this and despite exhortations to be "less invasive" (15), none of these methods have been widely employed.

The reasons for this are not difficult to discover. The above techniques have 3 major drawbacks.

- 1) They are cumbersome to perform. They require multiple pieces of equipment and critical manoeuvres. Often they require trial and error to find the proper conditions for a test.
- 2) They require a patient manoeuvre. The patient must actively perform some manoeuvre or it must be performed on the patient. This may be technically difficult and aesthetically unpleasing to the physician.
- 3) They require complex data analysis. Some techniques present difficulty in identifying data end points (8). Analysis of complex differential equations and polynomials is a difficult bedside procedure.

This study was undertaken to a) develop another noninvasive method for predicting  $\overline{P\text{VCO}_2}$  that had the advantages of

- i) being easy to apply in a clinical setting
  - ii) allowing the patient to continue to breathe at his own frequency and tidal volume, requiring no rebreathing or breathholding
  - iii) having a simple linear mathematical approach.
- b) to show the feasibility of the method.

## A. STUDIES WITH $N_2$ AS AN "INERT GAS"

### Rationale

We assumed the lung to

- a) be a single compartment container
- b) have instantaneous mixing
- c) have a volume "FRC" (functional residual capacity)
- d) expand and contract by a constant volume  
" $V_T$ " (tidal volume)

Consider a subject breathing spontaneously at rest, equilibrated to a gas such as  $N_2$  which is not absorbed from, or does not elute into, the lung. After normal exhalation the subject inhales a  $V_T$  of gas containing a fractional concentration of  $N_2$  ( $F_I N_2$ ) less than the previous equilibrated-to concentration. When he exhales, the end tidal  $N_2$  fractional concentration ( $F_E N_2$ ) will be less than the equilibrated concentration and greater than the  $F_I N_2$ . If the  $F_I N_2$  is 0 then the  $F_E N_2$  will be least. If the  $F_I N_2$  is equal to the equilibrated value then the  $F_E N_2$  will be equal to the  $F_I N_2$ .<sup>\*1</sup>

To explore the relationship between FRC,  $V_T$ ,  $F_I N_2$  and  $F_E N_2$  we conducted the following experiment.

### EXPERIMENT 1: Single breath $N_2$ testing

#### Method

Six normal healthy male volunteers were studied. Subjects were at rest and were initially breathing through a mouthpiece and a

---

1\* We are ignoring the small fluctuation in concentration caused by the discrepancy in  $O_2$  absorption and  $CO_2$  production.



circuit depicted in Fig. 1. The circuit had two one-way valves allowing inhalation from one limb and exhalation through another. The inhalational limb contained a stopcock which allowed either room air or test gas to enter it. Gas sampling was done through a catheter originating close to the mouth. Expiratory volumes were measured by a rolling seal spirometer connected to the expiratory part of the circuit.

Subjects breathed room air through the circuit until they developed a regular pattern of respiration. At the end of an exhalation, the stopcock was turned so that the next four breaths consisted of test gas. The subject then went back to breathing room air. After a period of at least 5 minutes the process was repeated with another test gas. A total of four test gases containing  $N_2$  concentrations between 2% and 60% were used for each subject.

Continuous gas sampling was done by a Perking-Elmer MGA-1100 Medical gas analyzer which was recalibrated with known gases before each subject was tested. The volume and gas analysis data was digitalized at a rate of 37 samples per second and stored on disk by a Norstar Horizon microcomputer. All volumes were corrected for the sampled gas.

The results of the experiment are tabulated in Table 1. Figure 2 is a bar graph made from the data of H.S. It illustrates the effect of various  $F_I N_2$ 's on the  $F_E N_2$ . The minimum  $F_E N_2$  occurs at the minimum  $F_I N_2$ . Fig. 3 shows that the difference between inspired and expired  $N_2$  concentrations bears a linear relationship to the  $F_I N_2$ .

Discussion

The linear relationship between  $F_E N_2 - F_I N_2$  and  $F_I N_2$  can be explained as follows. Again assume the mechanical characteristics of the lung with respect to  $N_2$  are those of a single chamber with instantaneous mixing of inspired gas (Fig. 4). A breath is taken of a known  $N_2$  concentration of volume  $V_T$ . The expired concentration will be the total amount of  $N_2$  in the lung divided by the total lung volume (16),(18). Stated in symbols:

$$F_E N_2 = \frac{(V_T \times F_I N_2) + F_{FRC} N_2 \times FRC}{V_T + FRC} \quad (1)$$

where  $F_{FRC} N_2$  is the  $N_2$  concentration in the FRC.

Subtracting  $F_I N_2$  from both sides,

$$F_E N_2 - F_I N_2 = \frac{(V_T \times F_I N_2) + (F_{FRC} N_2 \times FRC)}{V_T + FRC} - F_I N_2 \quad (2)$$

$$= \left( \frac{V_T}{V_T + FRC} - 1 \right) F_I N_2 + \frac{F_{FRC} N_2 \times FRC}{V_T + FRC} \quad (3)$$

Equation 3 is in the form  $y = mx + b$ , describing the linear relationship between  $F_E N_2 - F_I N_2$  and  $F_I N_2$ .

The excellent correlation of these two variables illustrated in Table 1 stems from the constant  $V_T$  for each test as measured and the presumed small variation in FRC at the beginning of each test gas series. Clearly, as the  $V_T$  is known and the slope of the line

is known, the FRC can be calculated from the slope of equation 3. This is the subject of work in progress at our laboratory.

We conclude that the first breath of nitrogen is distributed over a volume of the lung which behaves as a single chamber with instantaneous mixing. It is this characteristic which gives a linear relationship between  $F_{EN_2}$  and  $F_{IN_2}$ .

If one had a situation where the  $F_{FRC}$  of gas was unknown (and reconstituted between tests) one could use the approach of stimulus (a breath of different concentration gas) and response ( $F_E$ ) to calculate it. Any two points on an  $F_E - F_I$  vs  $F_I$  graph would define a line which crosses the abscissa at  $F_I = F_{FRC}$ , as can be seen from equation 3 by setting the left hand side equal to 0.

B. STUDIES TO EXAMINE THE METHOD FOR DETERMINING THE MIXED VENOUS  $\text{PCO}_2$  ( $\bar{P}\text{VCO}_2$ ) NON INVASIVELY

Rationale

To predict whether we could expect a similar linear relationship between inspired, expired and FRC concentrations of  $\text{CO}_2$ , we considered the effect of dilution and diffusion on the  $F_E\text{CO}_2$ .

If we imagine an instantaneous inspiration of  $V_T$  containing some  $\text{CO}_2$ , the instantaneous end inspiratory  $F_{\text{FRC}}\text{CO}_2$  should bear a linear relationship to the  $F_I\text{CO}_2$  as was shown for  $\text{N}_2$  in the previous section, ignoring for the moment any  $\text{CO}_2$  diffusion into the lung from blood or tissue stores.

Knowles et al (16), Dubois (19), Fenn and Dejours (18) showed that the change in  $\text{CO}_2$  tension in the lung per unit time varies directly as the  $\text{CO}_2$  gradient between mixed venous blood and the alveoli. In a regular pattern of respiration the diffusion time is constant. We can expect therefore, the change in  $\text{CO}_2$  tension in the lung to be directly proportional to this  $\text{CO}_2$  gradient.

Fig. 5 represents a schematic summary of the above events. We assume the mixed venous blood has a partial pressure equivalent to a  $\text{CO}_2$  concentration of an arbitrary value "8". Breathing room air ( $F_I\text{CO}_2 = 0$ ), the end tidal  $\text{CO}_2$  concentration is diluted to "4". This induces a gradient from mixed venous blood to alveoli of "4". In the duration of a breath, carbon dioxide diffuses into the lung in an amount sufficient to return the concentration back to "7".

In experiment 2 in Fig. 5, we assume the events take place before one recirculation time so that the equivalent mixed venous  $\text{CO}_2$  concentration stays constant at "8". The subject begins to breathe a

gas containing a  $F_I\text{CO}_2$  greater than 0 but less than the mixed venous value. At equilibrium, the end inspiratory diluted  $F_{\text{FRC}}\text{CO}_2$  will be greater than the previous value (when  $F_I\text{CO}_2$  was 0). The gradient for  $\text{CO}_2$  between mixed venous blood and alveoli is diminished compared to breathing room air. There will be a proportionately smaller amount of  $\text{CO}_2$  diffusing into the alveoli. The  $F_E\text{CO}_2$  will be greater than in expt. 1 but less than the mixed venous value. Similar events occur in experiment 3 and 4 each of which also represents a step change for a subject equilibrated to room air.

In expt. 5 the subject inhales a concentration of  $\text{CO}_2$  equal to that of his mixed venous blood. After one or more breaths the  $\text{CO}_2$  entering the lungs from the mixed venous blood and inhaled gas bring the alveolar concentration to the mixed venous value and there is no difference between  $F_I\text{CO}_2$  and  $F_E\text{CO}_2$  as long as the test time is less than a recirculation time.

Experiment 6 also represents a continuation of this argument for the inhalation of a gas whose  $F\text{CO}_2$  is greater than that of the mixed venous blood. The dilution argument holds unchanged. Knowles (16) has also shown that the amount of  $\text{CO}_2$  diffusing back into the lung per unit time continues to be directly proportional to the gradient.

In summary, with respect to  $\text{CO}_2$ , the  $F_E\text{CO}_2$  is proportional to the amount of  $\text{CO}_2$  diffusing into the alveoli which is proportional to the mixed venous - alveolar  $\text{CO}_2$  gradient which itself is proportional to the  $F_I\text{CO}_2$ . Therefore, we could expect a linear relationship between  $F_E\text{CO}_2 - F_I\text{CO}_2$  and  $F_I\text{CO}_2$  (Fig. 6).

## Experiment 2: Third breath CO<sub>2</sub> test

### Methods

Six normal male volunteers were studied. Subjects were at rest and were breathing through a circuit identical to one described for nitrogen testing (Fig. 1). The test gases consisted of CO<sub>2</sub> in O<sub>2</sub> and N<sub>2</sub> mixtures. The F<sub>I</sub>CO<sub>2</sub> varied from 2% to 8%. The F<sub>I</sub>O<sub>2</sub> was greater than 30%.

In the test sequence the subject was allowed to breathe through the circuit until a regular pattern of respiration had developed. At the end of a normal exhalation the stopcock was turned and the subject inhaled four breaths of a test gas trying not to change the depth and frequency of his breaths. At the end of four breaths the subject was returned to breathing room air for at least 15 minutes before another test gas was applied. A total of four tests were performed on each subject.

Inspired and expired CO<sub>2</sub> was monitored continuously by a Perkins-Elmer MGA-1100 Medical gas analyzer. The volumes were measured by a rolling seal spirometer. All instruments were recalibrated before each subject was tested. All data were automatically digitalized and stored on disk by a Norstar Horizon microcomputer.

### Results

Table 2 lists the results of changes in expired CO<sub>2</sub> concentration resulting from test gases containing different F<sub>I</sub>CO<sub>2</sub>'s. It also lists the linear regression equation and correlation coefficients for the F<sub>E</sub>CO<sub>2</sub> - F<sub>I</sub>CO<sub>2</sub> vs F<sub>I</sub>CO<sub>2</sub> lines for each subject. Figure 7 graphs F<sub>I</sub>CO<sub>2</sub>

vs  $F_E\text{CO}_2 - F_I\text{CO}_2$  for subject H.S. ( $r=-0.999$ ). This graph illustrates the linear relationship of the points.

Our hypothesis is that the intercept with the abscissa of this easily generated line is related to the mixed venous  $\text{PCO}_2$  (Table III).

Experiment 3: Comparison of third breath  $\bar{P}\text{VCO}_2$  prediction to invasive  $\bar{P}\text{VCO}_2$

Methods

This protocol was approved by the University of Toronto and St. Michael's Hospital Animal Care Committee. Five mongrel dogs were anesthetized with nembutal 30 ml/kg and pancuronium bromide .04 mg/kg. Both drugs were supplemented as necessary. The trachea was intubated with a cuffed #9 Portex endotracheal tube. One dog was tested during spontaneous ventilation at various depths of anesthetic and 4 dogs had controlled ventilation.

a) Circuit for controlled ventilation: The dogs were ventilated with a Bennet MA1 ventilator with a  $V_T$  of 12 ml/kg. The ventilator was attached to a circuit as illustrated in Fig. 8 and 9. The ventilator was found to deliver a constant tidal volume between the rates of 6/min and 30/min. The circuit consisted of a "bag in a bottle" set up. This was initially constructed from two, three litre rubber anesthesia bags inside a 5 litre bottle. The bottle neck had 2 openings. One opening was attached to a mushroom valve which occluded it during the inspiratory phase of the ventilator. The other opening was attached to the circuit by a 3-way respiratory stopcock. The test gas bag was attached to the circuit proximal to the dog by another

respiratory stopcock. Proximal to this stopcock was the inspiratory limb of the circuit with a one way valve allowing gas to enter the circuit but not to waft back into the bag. Exhalation was accomplished through a port proximal to the one way valve. This port was also closed by a mushroom valve during the inspiratory phase of the ventilator. Thus during the control phase of the experiment the inspired volume bypassed the bottle and entered the dog (Fig. 8). For the test phase, the anesthesia bag was prefilled with a test gas containing a  $\text{CO}_2$  concentration 0% - 8%. During exhalation the stopcocks were turned so that the next tidal volume from the ventilator entered the bottle (Fig. 9) and displaced an equal volume of gas from the bag into the dog. After 4 breaths the stopcocks were turned to the original position. The dog was again ventilated directly by the ventilator. The bag was filled with a test gas containing another  $\text{CO}_2$  concentration. After restoration of equilibrium, the test was be repeated with the new test gas.

Test gases were pre-mixed from 100%  $\text{CO}_2$  and 100%  $\text{O}_2$  and stored in identical, unlabeled Douglas bags. Their composition was changed throughout the day by adding  $\text{CO}_2$  or  $\text{O}_2$  to the bags.

#### b) Vascular lines and monitors

Once anesthetized, the dogs had their femoral artery cannulated. A silastic pulmonary catheter was passed through the external jugular vein. Both catheters were monitored constantly for pressure. Blood was sampled from the vascular catheters and analyzed for hemoglobin concentration, blood gases, and pH. Temperature was monitored by an electronic rectal temperature probe. Tidal  $\text{PCO}_2$  was constantly sampled at the mouth and analyzed by an infra-red



capnograph (Beckman model LB2). All values were recorded continuously on a Beckman type RM dynagraph recorder.

c) Protocol

One dog was anesthetised and the trachea intubated. After placement of the vascular catheters, test gases containing 0 - 8% CO<sub>2</sub> were applied via a circuit as illustrated in Fig 1. As the anesthetic began to wear off and the dog's minute ventilation increased, the test gases were again applied.

Four dogs were ventilated throughout the experiment at a constant V<sub>T</sub> of 10 - 12 ml/kg. The frequency setting on the ventilator was set and the dog was allowed to come to a steady state with respect to his mixed venous PCO<sub>2</sub>. This was judged to occur when two successive P $\bar{V}$ CO<sub>2</sub> values (aspirated from the pulmonary arterial catheter) aspirated within 5 minutes of each other differed by less than 2 mm Hg. When this occurred a blood sample was drawn from the femoral artery and pulmonary artery catheters and analyzed for pH, PCO<sub>2</sub>, PO<sub>2</sub> and Hb. A test consisted of 4 breaths of a test gas containing an amount of CO<sub>2</sub> between 0 and 8%. After 4 breaths the dog again was ventilated directly by the ventilators for 3 - 5 minutes while the anesthetic bag in the bottle was being filled with another test gas. The test gases were applied without consideration of their CO<sub>2</sub> concentration or their previous order of use.

When at least 2 test gases had been applied the ventilator frequency was changed and the dog allowed again to come to a new equilibrium with respect to his P $\bar{V}$ CO<sub>2</sub>. The above process was again repeated at the new P $\bar{V}$ CO<sub>2</sub>.

d) Data analysis

i) Calculation of non invasive mixed venous  $\text{CO}_2$  CONTENT.

The  $F_I\text{CO}_2$ ,  $F_E\text{CO}_2$  and temperature were read from the previously calibrated strip recorder. The highest end tidal  $F\text{CO}_2$  of the third breath was taken as the  $F_E\text{CO}_2$ . A linear regression equation of the  $F_I\text{CO}_2$ ,  $F_E\text{CO}_2 - F_I\text{CO}_2$  pairs was computed and the line extrapolated to the point of crossing the abscissa. The fraction of  $\text{CO}_2$  at the intercept was converted to partial pressure. This value was assumed to be the  $P\bar{V}\text{CO}_2$ . The pulmonary capillary  $P\text{O}_2$  was calculated from the alveolar gas equation. The base excess and hemoglobin from the invasive value were used to complete the calculation of  $\text{CO}_2$ . These data were entered into the BASIC translation of a program for converting  $P\text{CO}_2$  to  $\text{CCO}_2$  by Olszowka et al. (17).

ii) The invasive  $\text{CCO}_2$  was calculated in the same way using the measured  $P\bar{V}\text{CO}_2$ ,  $P\bar{V}\text{O}_2$ , Hemoglobin, and pH.

## RESULTS

Results are tabulated in Table 4. Dog 1 was breathing spontaneously from room air. The first test was done soon after induction of anesthesia. The dog was very deeply anesthetized as evidenced by its relative hypotension and respiratory depression. The respiratory rate was 4 per minute and irregular in depth and pattern. We include this point as raw data but it does not fall within the criteria for inclusion in the study. During the subsequent tests the respirations became more regular.

The remainder of the dogs were studied under controlled ventilation.

Dogs 2 and 3 which were being ventilated by the secondary circuit we had constructed initially had a significant drop in their tidal volume when they were switched into the secondary circuit. This drop in tidal volume was caused by the added compliance of the animal-circuit system into which the ventilator delivers its constant tidal volume. Since the control tidal volume was greater than the test tidal volumes for dogs #2 and #3, the room air control value was not incorporated into the calculation of  $\bar{P}\bar{V}\text{CO}_2$ . Theoretically, the remaining test values should still predict the  $\bar{P}\bar{V}\text{CO}_2$  despite this sudden decrease in  $V_T$ . To correct for this problem a smaller "bag in the box device" was constructed giving only a 10-12% drop in  $V_T$  in dogs #4 and #5. We therefore incorporated these control values in the mixed venous  $\text{PCO}_2$  calculation.

Fig. 10 illustrates data obtained from dog #3. The intercepts of the regression lines with the abscissa are taken as the mixed venous  $\text{PCO}_2$ .

In Fig. 11 we plot noninvasive vs invasive  $PCO_2$ . The regression equation for this line is  $y = 1.37x + 9.71$  ( $r=0.96$ ). The non invasive  $PCO_2$  prediction is that of  $O_2$  saturated blood whereas the blood aspirated from the pulmonary artery is  $O_2$  desaturated. This could account for the higher noninvasive values (ref 5). Theoretically, however, the content of  $CO_2$  should be the same using a  $P\bar{V}CO_2$  calculated from either technique. In Fig. 12 we plot the  $CO_2$  content as calculated by the new non invasive against that calculated by the invasive technique. The regression equation for the line is  $y = 1.16x - 6.33$ . The slope was found not to differ significantly from 1.0 and the intercept was found not to differ significantly from 0 ( $p>0.1$  for both).

## DISCUSSION

### 1. Model rationale

#### a) Single compartment model for $CO_2$ .

Dubois (19) Fenn and Dejours (18) define a term "equivalent lung volume for  $CO_2$  "ELV" which includes the air space volume which the breath distributes to as well as the effect of the breath on dissolved  $CO_2$  stores such as lung tissue and blood. In this concept the  $CO_2$  entering the gas spaces during early parts of the inspiratory cycle come from fast space tissue buffers. If gas is sampled early this would give an apparent greater volume of distribution to a breath of air. This difference in volume of breath distribution between  $CO_2$  and  $N_2$  is very small but measureable (18). Otherwise, these authors have considered their data and calculations consistent with the model of the lung as having a single compartment. Fenn and

Dejours also showed that a single breath result is not altered by mixing attempts such as rapid rebreathing. In fact all their data as well as ours are consistent with the model of the lung as a single compartment container with instantaneous mixing.

b) The role of  $\bar{v}$ -A gradient in determining  $P\bar{V}CO_2$ .

In determining the end tidal  $PCO_2$  of a subject breathing room air (0%  $CO_2$ ), the model assumes that the  $V_T$  of fresh air dilutes the existing concentration in the FRC, establishing an instantaneous end-inspiratory  $\bar{v}$ -A gradient. An amount of  $CO_2$  proportional to this gradient diffuses into the FRC, increasing the FRC concentration to its final value of the  $F_ECO_2$ .

Now assume that a test gas containing an amount of  $CO_2$  is breathed for 3 breaths. The resultant  $F_ECO_2$  values will represent a rise towards a new equilibrium value of  $F_ECO_2$  (before a recirculation time). This new equilibrium value is determined by two interacting effects: one a dilution effect, the other a diffusion effect.

The test gas serves to dilute the gas in the FRC, although now the dilution effect is smaller due to the presence of the  $CO_2$  in the inspired test gas. This results in successively higher end inspiratory  $F_{FRC}$  values analagous to the "wash in" effect of any test gas. Because the end-inspiratory  $F_{FRC}$  values are higher, however, the  $\bar{v}$ -A gradient is smaller, so that less  $CO_2$  diffuses into the lung from the venous blood during the fixed period of a breath. It is this reduction in gradient which causes the  $F_ECO_2$  values to level off at a new equilibrium value. These two effects, taken together establish the new  $F_ECO_2$ .

The technique to determine  $\bar{FVCO}_2$ , assumes that if  $\bar{FVCO}_2$  were inhaled, the equilibrium  $F_{FRC}$  would rise to  $\bar{FVCO}_2$  thereby eliminating the gradient. Thus, no  $CO_2$  would diffuse into the lung and the expired concentration would also be equal to  $\bar{FVCO}_2$  (i.e. the difference between inspired and expired concentrations will be 0).

Using reasoning analogous to that used to develop equation 1 for  $N_2$ , we state the formula for the end inspiratory  $CO_2$  concentration in the FRC

$$F_{FRC_{EI}} = \frac{V_T \cdot F_I + F_{FRC_{EE}} \cdot FRC}{V_T + FRC} \quad (4)$$

Where  $F_{FRC_{EI}}$  = Fractional concentration of  $CO_2$  in the FRC at the end of inspiration

$F_{FRC_{EE}}$  = Fractional concentration of  $CO_2$  in the FRC end exhalation

$V_T$  and FRC refer to the volume in milliliters of the tidal volume and functional residual capacity respectively.

That this is a linear function of the inspired  $CO_2$  concentration can be shown by simple re-writing of the equation in the form

$$F_{FRC_{EI}} = \left[ \frac{V_T}{V_T + FRC} \right] F_I + \frac{F_{FRC_{EE}} \cdot FRC}{V_T + FRC} \quad (5)$$

For the sake of formula simplification, let  $m = \frac{V_T}{V_T + FRC}$

$$\text{and } b = \frac{F_{FRC_{EE}} \cdot FRC}{V_T + FRC}$$

The amount of CO<sub>2</sub> diffusing into the lung for a given time (ACO<sub>2</sub>) varies directly as the CO<sub>2</sub> concentration gradient between the mixed venous blood and the alveoli:

$$A_{CO_2} = k (F\bar{V} - F_{FRC_{EI}}) \quad (6)$$

where  $F\bar{V}$  = mixed venous concentration. The end tidal CO<sub>2</sub> concentration ( $F_E$ ), then must be the sum of the CO<sub>2</sub> in the lung at end inspiration plus the amount diffused in, divided by the net lung volume.

$$F_E = \frac{V_T \cdot F_I + F_{FRC_{EE}} \cdot FRC + k(\bar{v} - F_{FRC_{EI}})}{V_T + FRC} \quad (7)$$

Substituting for  $F_{FRC_{EI}}$  from Eq. 5 and subtracting  $F_I$  from both sides to change the formulation to identify our end point:

$$F_E - F_I = \frac{V_T \cdot F_I + F_{FRC_{EE}} \cdot FRC + k(F\bar{V} - mF_I - b)}{V_T + FRC} - F_I \quad (8)$$

$$\left( \frac{V_T - km}{V_T + FRC} - 1 \right) F_I + \frac{F_{FRC_{EE}} \cdot FRC + k(F\bar{V} - b)}{V_T + FRC} \quad (9)$$

As was illustrated in Fig. 5, this formula represents a summation of two lines that we expect to cross the abscissa at  $F_VCO_2$ . As test gases whose  $F_I CO_2$  approach  $v$  values are given, the  $F_{FRC_{EI}}$  rises and the  $D(\bar{v}-A)CO_2$  falls. When  $F_I CO_2$  is equal to the  $F_VCO_2$ ,  $CO_2$  gas will be added to the  $F_{FRC_{EE}}$  until it is equal to the  $F_VCO_2$ . Subsequent breaths taken before recirculation should reflect the fact that  $F_I CO_2 = F_{FRC_{EI}} CO_2 = F_VCO_2 = F_{FRC_{EE}} CO_2 = F_E CO_2$ .

d) Expected influences on the  $F_E - F_I$  vs  $F_I$  curve

i) Dead space ( $V_D$ ).

It is expected that the presence of dead space will not affect the determination of  $F_VCO_2$  by this technique.

If the dead space has a long time constant and a low  $V/Q$ , one would expect it to have an  $F_{V_D} CO_2$  close to that of the mixed venous blood, and to contribute minimally to  $F_E$ .

If the dead space has a short time constant, and thus a high  $V/Q$ , the  $F_{V_D} CO_2$  can be expected to be close to 0 when breathing room air.

Considering the  $F_E CO_2$  of the first breath, it is possible that an  $F_I CO_2$  lower than  $F_VCO_2$  would yield the result of  $F_E CO_2 = F_I CO_2$ , thus underestimating  $F_VCO_2$ .

The reason for this is that when the first breath of test gas is inhaled, the  $F_{V_D} CO_2$  rises slightly from zero to some value below  $F_I CO_2$  while the  $F_{FRC}$  rises slightly to a value higher than  $F_I CO_2$ . When the subject exhales, these two concentrations may combine to yield  $F_E CO_2 = F_I CO_2$ .



The case for  $F_E CO_2$  of the third breath is different however. By the third breath, the  $F_{V_D} CO_2$  approaches  $F_I CO_2$ , since its time constant is small and  $\dot{V}/Q$  high. The  $F_{FRC}$  is higher than  $F_I CO_2$  since it also contains the  $CO_2$  that diffuses into the lung. The value of  $F_E CO_2$ , therefore, must be higher than  $F_I CO_2$  since it is a combination of the two concentrations,  $F_{V_D} CO_2 = F_I CO_2$  and  $F_{FRC} CO_2 > F_I CO_2$ .

The  $F_E - F_I$  line for a subject with dead space will still pass through  $F_I CO_2 = F_V CO_2$  if  $F_E CO_2$  of the third breath is considered, since then

$$F_{V_D} CO_2 = F_V \text{ and } F_{FRC} = F_{\bar{V}}.$$

The combination of these two equal concentrations to form  $F_E CO_2$  will still yield  $F_E CO_2 = F_{\bar{V}} CO_2$ .

ii) Right to left shunt ( $Q_S/Q_T$ )

Shunted blood will alter the arterial  $PCO_2$  which in turn will affect the  $P_{\bar{V}} CO_2$ . As it is the same  $P_{\bar{V}} CO_2$  that perfuses all areas of the lung, no systematic error in predicting the  $P_V CO_2$  in predicting the  $P_{\bar{V}} CO_2$  is expected on this basis alone with the technique. The Fick technique is otherwise still valid in the presence of shunted blood.

iii) Cardiac output

The difference in slope between a first breath  $N_2$  line and the equilibrium  $CO_2$  line is related to a "diffusion constant"  $k$  (Eq. 6 and 9) which probably reflects cardiac output influences as well as diffusion. For these experiments and equations we assume a

constant cardiac output during each test. For clinical purposes where  $\bar{P}\bar{V}\text{CO}_2$  is predicted from only one test gas result, it is assumed that C.O. was constant during the 20 seconds or so of the test.

e) Physiologic effect of breathing  $\text{CO}_2$

Fowle and Campbell (21) showed the short term capacitance of the body for  $\text{CO}_2$  is 40 ml  $\text{CO}_2/\text{mm Hg PCO}_2$ . For an  $F_I\text{CO}_2$  equal to the  $\bar{P}\bar{V}\text{CO}_2$  for 3 breaths over 15 sec. and a  $\text{CO}_2$  production of 200 ml/min we can expect 50 ml of  $\text{CO}_2$  to be retained by the body. This would give an approximately 1 mm Hg rise in tissue  $\text{PCO}_2$ , presumably reflected in the recirculated  $\bar{P}\bar{V}\text{CO}_2$ . If a test gas contains only a fraction of the  $\bar{F}\bar{V}\text{CO}_2$ , only that fraction of the  $\text{CO}_2$  can be expected to be retained giving a negligible rise in recirculated  $\bar{P}\bar{V}\text{CO}_2$ . Therefore in situations where pulmonary gas mixing is poor, allowing the test to proceed into the next recirculation time while using low  $F_I\text{CO}_2$  may yield better results on balance.

f) Relation of the technique to previously described techniques.

The technique we describe shares a number of theoretical points with previous techniques which we have used as a foundation. DuBois et al (4) established the concept of an "equivalent alveolar lung volume" or EVL. This was later used by Knowles et al (16) using  $\text{N}_2$  as a marker for the distribution of an inhaled volume. In this study we called this the  $\text{FRC}_{\text{EI}}$  which is the net volume of distribution of a breath. Although this may or may not be the "FRC" as measured by body plethysmography or inert gas dilution it can be defined as that volume that a known amount of indicator gas is diluted by.

These authors are also credited with being the first to demonstrate the exponential rise of  $\text{CO}_2$  in the lung during breathholding. This information was later used by Defares (6) and Collier(7) to extrapolate to  $\bar{P}\text{VCO}_2$ . Knowles (16) however used this information to demonstrate that the amount of  $\text{CO}_2$  entering the lung per unit time was a linear function of the pulmonary capillary to alveolar concentration gradient. We used this information to predict the persistent linearity of the  $F_E - F_I$  vs  $F_I$  curve for  $\text{CO}_2$ .

Despite this agreement on the basics, all of the previous techniques have in common attempts to equilibrate pulmonary gases to  $\bar{P}\text{VCO}_2$ . Some methods involve finding conditions where this equilibration occurs (7, 8). The other methods set conditions where equilibration is approached physically and the final value is calculated mathematically (5, 6).

Our technique is based however on stimulus and response. A breath of known concentration of gas is given and from the expired concentration of that gas all calculations are made. Each test in effect gives 2 points. The point from room air ( $F_I\text{CO}_2=0$ ,  $F\text{N}_2=.79$ ) and the test gas. An extrapolation from a straight line through these two points is all the analysis that is required.

#### SUMMARY

We presented a technique for estimating mixed venous partial pressure. The technique is based on previously accepted principles of pulmonary physiology. The approach involves applying an inspired concentration of  $\text{CO}_2$  other than 0 and observing the expired concentration. We developed the theoretical and mathematical basis

for the technique.

Unlike previously described methods, the present technique is simple to perform. The calculation of  $\bar{P}\bar{V}\text{CO}_2$  requires only the application of three or four breaths of a test gas while the patient continues to breath in his usual fashion. The technique is valid in spontaneous breathing as well as ventilated subjects.

For the calculation of  $\bar{P}\bar{V}\text{CO}_2$ , inspired and expired  $\text{FCO}_2$  is monitored continuously. End tidal  $\text{CO}_2$  for  $\text{F}_\text{I}\text{CO}_2$  of 0 and the third breath of at least one test gas is noted. Data analysis consists of plotting  $\text{F}_\text{E}\text{CO}_2 - \text{F}_\text{I}\text{CO}_2$  vs  $\text{F}_\text{I}\text{CO}_2$  for the control gas ( $\text{F}_\text{I}\text{CO}_2 = 0$ ) and at least one test gas. A straight line is fit through these points and extrapolated to its intersection of the abscissa.

We have demonstrated that this data is easy to obtain, has an easily definable end point and correlates highly with invasively obtained  $\bar{P}\bar{V}\text{CO}_2$ .

The technique shows advantages over previously described techniques and as such shows promise as a basis for a new clinical method for measuring non invasive cardiac output.

## REFERENCES

1. Grollman, A.: The cardiac output of man in health and disease, Charles C. Thomas, Baltimore Md., 1932.
2. McEvoy, J.D.S., Jones, N.L., Campbell, E.J.M.: Mixed venous and arterial  $PCO_2$ . British Medical Journal 4:687-690, 1974.
3. Richards, D.W. Jr., Strauss M.: The carbondioxide and oxygen tensions of mixed venous blood of man at rest. J. Clin. Invest. 9:475-532, 1930.
4. DuBois, A.B., Britt, A.G., Fenn, W.O.: Alveolar  $CO_2$  during the respiratory cycle. J. Appl. Physiol. 4:535-548, 1952.
5. Frankel, D.Z.N., Mahutte, C.K., Rebuck, A.S.: A noninvasive method for measuring the  $PCO_2$  of mixed venous blood. Am. Rev. of Resp. Dis. 117:63-69, 1978.
6. Defares, J.G.: Determination of  $PvCO_2$  from the exponential  $C_2$  rise during rebreathing. J. Appl. Physiol. 13(2):159-163, 1958.
7. Collier, C.R., Determination of mixed venous  $CO_2$  tensions by rebreathing. J. Appl. Physiol. 9:25-28, 1956.
8. Powles, A.C.P., Campbell, E.J.M.: An improved rebreathing method for measuring mixed venous carbon dioxide tensions and its clinical application. Can. Med. Ass. J. 118:501-504, 1978.
9. Frankel, D.Z.N., Sandham, G., Rebuck, A.S.: A new method for measuring  $PCO_2$  during anesthesia. Br. J. Anaesth. 51:215-219, 1979.
10. Francoisa J.A., Ragan, D.O., Rubenstone, S.J.: Validation of the  $CO_2$  rebreathing method for measuring cardiac output in

- patients with hypertension or heart failure. J. Lab. Clin. Med. 88(4):672-681, 1976.
11. Hackney, J.D., Sears C.H., Collier, C.R.: Estimation of arterial CO<sub>2</sub> tension by rebreathing technique. J. Appl. Physiol. 12:425-430, 1958.
  12. McEvoy, J.D.S., Jones, N.L., Campbell, E.J.M.: Alveolar-arterial PCO<sub>2</sub> difference during rebreathing in patients with chronic hyperapnea. J. Appl. Physiol. 35(4):542-545, 1973.
  13. Davis, C.C., Jones, N.L., Sealey, B.J.: Measurements of cardiac output in seriously ill patients using CO<sub>2</sub> rebreathing method. Chest 73:167-172, 1978.
  14. Franciosa, J.A.: Evaluation of the CO<sub>2</sub> rebreathing cardiac output method in seriously ill patients. Circulation 55(3):449-455, 1977.
  15. Powles, A.C.P., Campbell, E.J.M.: How to be less invasive. Am. J. Med. 67: 98-104, 1979.
  16. Knowles, I.H., Newman, W., Fenn, W.O.: Determination of oxygenated mixed venous blood CO<sub>2</sub> tension by breath-holding method. J. Appl. Physiol. 15(2):225-228, 1960.
  17. Olszowka, A., Farhi, L.E.: A system of digital computer subroutines for blood gas calculations. Respir. Physiol. 4:270-280, 1968.
  18. Fenn, W.O., Dejours, P.: Composition of alveolar air during breath holding with and without prior inhalation of O<sub>2</sub> and CO<sub>2</sub>. J. Appl. Physiol. 7: 313-319, 1954.
  19. Dubois, A.B., Alveolar CO<sub>2</sub> and O<sub>2</sub> during breath holding, expiration and inspiration. J. Appl. Physiol. 5(1): 1-12, 1952.

20. Gideon, A.: A new method for noninvasive bedside determination of pulmonary blood flow. *Med. and Biol. Eng. and Comput.*, 18, 411, 1980.
21. Fowle, A.S.E., Campbell, E.J.M.: The immediate carbon dioxide storage capacity of man. *Clin. Sci.* 27, 41-49, 1964.

Table 1: Human Subjects Breathing N<sub>2</sub> Concentrations 23-50%

Subject	V <sub>T</sub>	FIN2	FEN2	DN2	REGRESS. EQ'N	"r"
CA	-	77.97	78.61	0.64	Y = -0.842X + 66.12	-1.0
	753	55.82	74.64	18.82		
	742	40.42	72.82	32.40		
	762	22.95	69.40	46.45		
	725	2.16	66.66	64.50		
HS	-	78.03	79.45	1.42	Y = -0.824X + 65.95	-1.0
	846	56.45	74.64	20.19		
	815	40.42	72.82	32.40		
	838	22.95	69.40	46.45		
	840	2.16	66.66	64.50		
JF	-	78.17	80.20	2.03	Y = -0.875X + 71.37	-1.0
	491	57.76	78.92	21.16		
	511	41.17	76.72	35.55		
	510	26.76	74.86	48.12		
	515	5.75	71.19	65.44		
AO	-	77.52	77.54	0.02	Y = -0.903X + 70.58	-0.999
	742	57.01	76.32	19.72		
	673	41.23	75.76	34.53		
	815	24.58	71.44	46.86		
	726	4.69	71.39	66.70		
CE	-	77.60	80.10	2.50	Y = -0.845X + 68.86	-0.998
	566	57.71	79.50	21.79		
	579	41.30	74.58	33.28		
	551	25.96	72.74	46.78		
	562	7.28	72.39	65.11		
HI	-	77.32	78.18	0.86	Y = -0.817X + 64.15	-0.997
	941	56.12	73.6	17.51		
	850	40.09	71.14	31.05		
	906	23.04	67.31	48.31		
	948	3.18	62.93	59.75		

V<sub>T</sub> = inspired tidal volume (ml)

FIN2 = fractional inspired N<sub>2</sub> concentration (%)

FEN2 = fractional expired N<sub>2</sub> concentration (%), first breath of test gas

DN2 = FEN2 - FIN2



Table 2: Human Subjects Breathing CO<sub>2</sub> Concentrations 2%-8%

<u>Subject</u>	<u>V<sub>T</sub></u>	<u>F<sub>ICO2</sub></u>	<u>F<sub>ECO2</sub></u>	<u>DCO2</u>	<u>REGRESS. EQ'N</u>	<u>"r"</u>
AO	691	0	4.48	4.48	Y= -0.771X + 4.64	-0.997
	729	2.25	5.16	2.91		
	764	4.16	5.91	1.75		
	729	6.22	6.05	-0.17		
	762	7.94	6.29	-1.65		
CA	-	0.31	6.34	6.03	Y= -0.832X + 6.51	-0.996
	787	2.29	7.01	4.72		
	740	4.15	7.54	3.39		
	747	6.21	7.39	1.18		
	751	7.92	7.76	-0.16		
HS	-	0.21	5.53	5.32	Y= -0.799X + 5.72	-0.994
	862	2.30	6.65	4.35		
	963	4.16	6.43	2.27		
	857	6.20	6.85	0.65		
	884	7.99	7.37	-0.62		
HTS	813	0.10	5.78	5.68	Y= -0.81X + 5.89	-0.999
	908	2.30	6.41	4.11		
	1002	4.17	6.78	2.61		
	880	6.22	7.15	0.93		
	900	7.92	7.25	-0.67		
HI	782	0.14	5.82	5.68	Y= -0.798X + 5.80	-0.9998
	1086	2.26	6.30	4.04		
	831	4.18	6.63	2.45		
	839	6.24	7.00	0.76		
	884	7.91	7.44	-0.47		
JF	-	0.30	5.83	5.53	Y= -0.868X + 5.77	-0.9999
	537	2.40	6.05	3.65		
	490	4.23	6.34	2.11		
	535	6.26	6.60	0.34		
	506	7.94	-	-		
JS	-	0.13	5.33	5.20	Y= -0.781X + 5.28	-0.9997
	586	3.33	6.01	2.68		
	625	4.38	6.17	1.79		
	473	6.23	6.72	1.79		
	513	7.97	7.01	-0.96		

Table 3: "Mixed Venous PCO<sub>2</sub>" as Calculated from Data in Table 2

<u>Subject</u>	<u>Projected "PvCO<sub>2</sub>"</u>
AO	6.02 %
CA	7.82 %
HS	7.16 %
HTS	7.27 %
HI	7.27 %
JF	6.65 %
JS	6.76 %





Table 4:(continued)

<u>DoB</u>	<u>Wt.</u>	<u>FI</u>	<u>FE-FI</u>	<u>NIFCO2</u>	<u>NIPCO2</u>	<u>NICCO2</u>	<u>Hb</u>	<u>T</u>	<u>pH</u>	<u>IPC02</u>	<u>IPO2</u>	<u>ICC02</u>
4.	21.8	0.00	4.54	6.25	44.75	45.6	14.0	39.0	7.36	46.8	51.0	47.59
		7.23	-0.93									
		3.70	2.30									
		0.00	3.24	4.70	33.65	41.7	14.0	39.0	7.46	34.1	47.0	43.04
		3.77	0.86									
		7.55	-2.14									
5.	16.4	0.00	4.64	6.28	44.96	47.53	14.0	38.5	7.42	38.6	46.0	45.67
		1.73	3.15									
		7.10	-0.60									
		3.72	1.95									
		0.00	3.43	4.50	32.22	41.08	14.0	38.5	7.47	31.9	44.0	42.07
		3.67	0.74									
		6.12	-1.22									
		6.85	-1.71									
		3.57	0.48									

Wt.- weight of dog in Kg

NIPCO2- noninvasive PCO2 in mm Hg

NICCO2- noninvasive CO2 content in mlCO2/100 ml blood

T- dog temperature in degrees Celsius

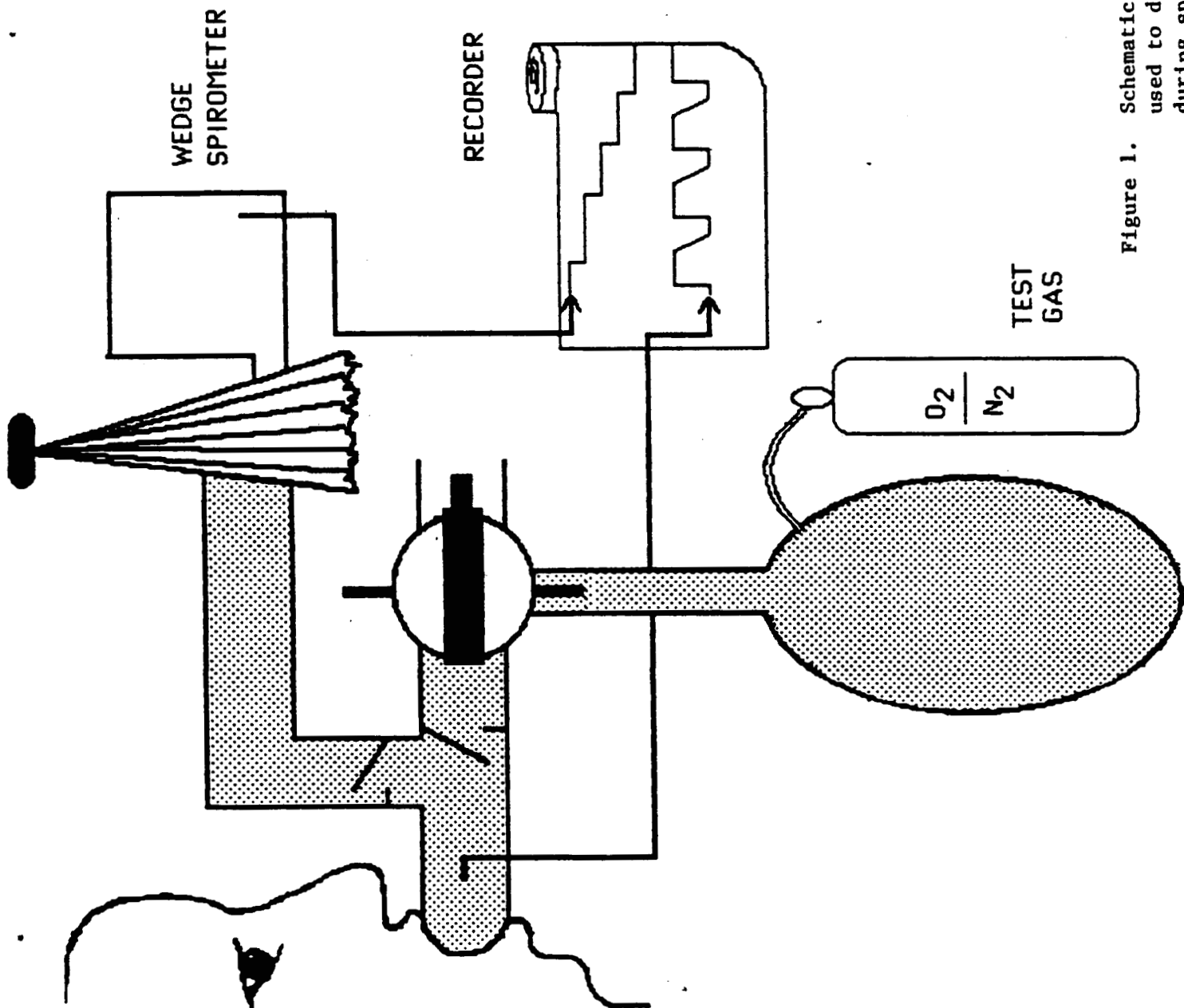

Figure 1. Schematic diagram of circuit used to deliver a test gas during spontaneous ventilation.

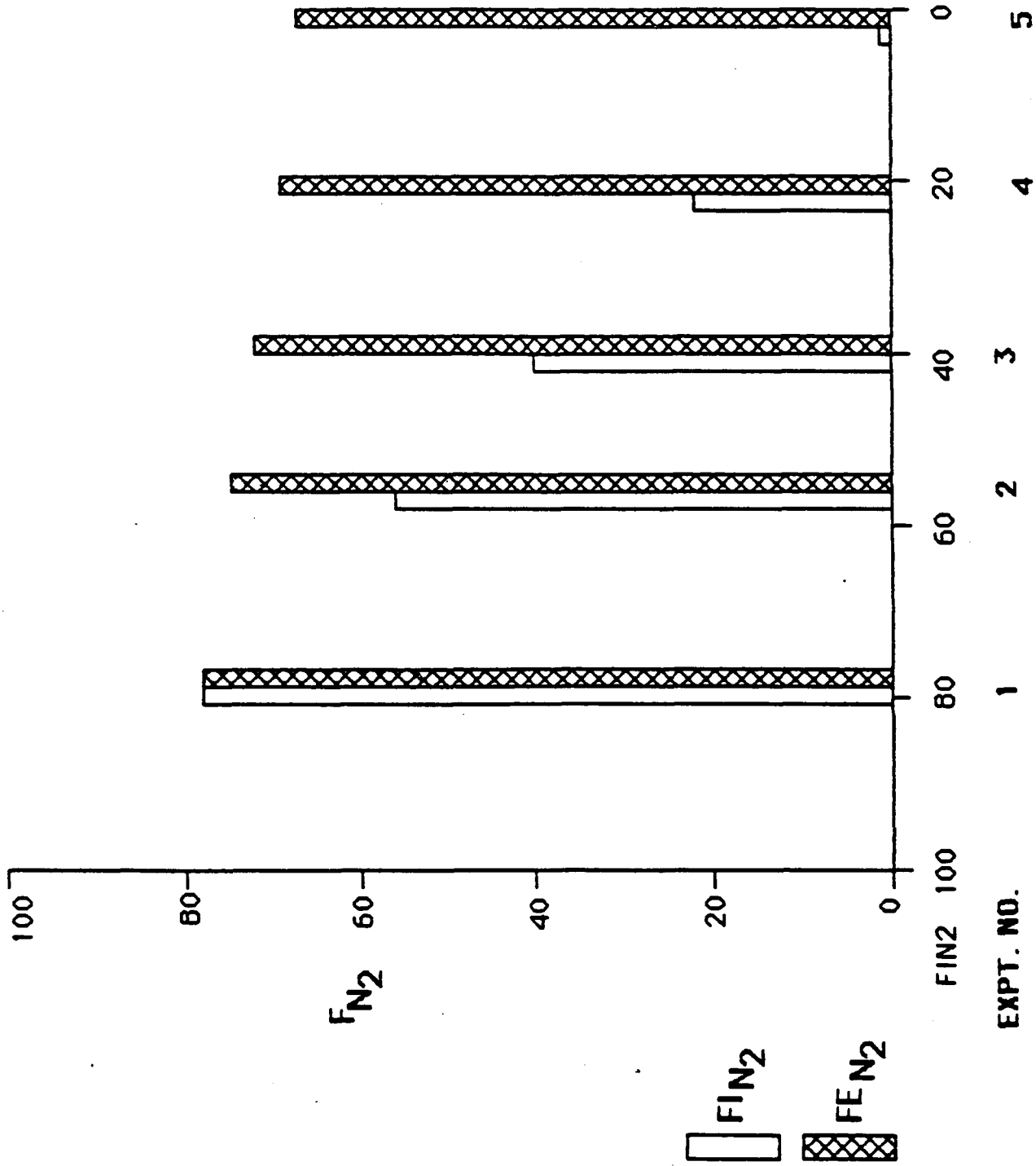

Figure 2. Inspired and expired nitrogen concentrations for subject H.S. Each experiment consisted of breathing one breath at normal tidal volume of a gas with a N<sub>2</sub> concentration less than room air. The subject equilibrates with room air between tests.

H.S. FE-FI VS FI : N2

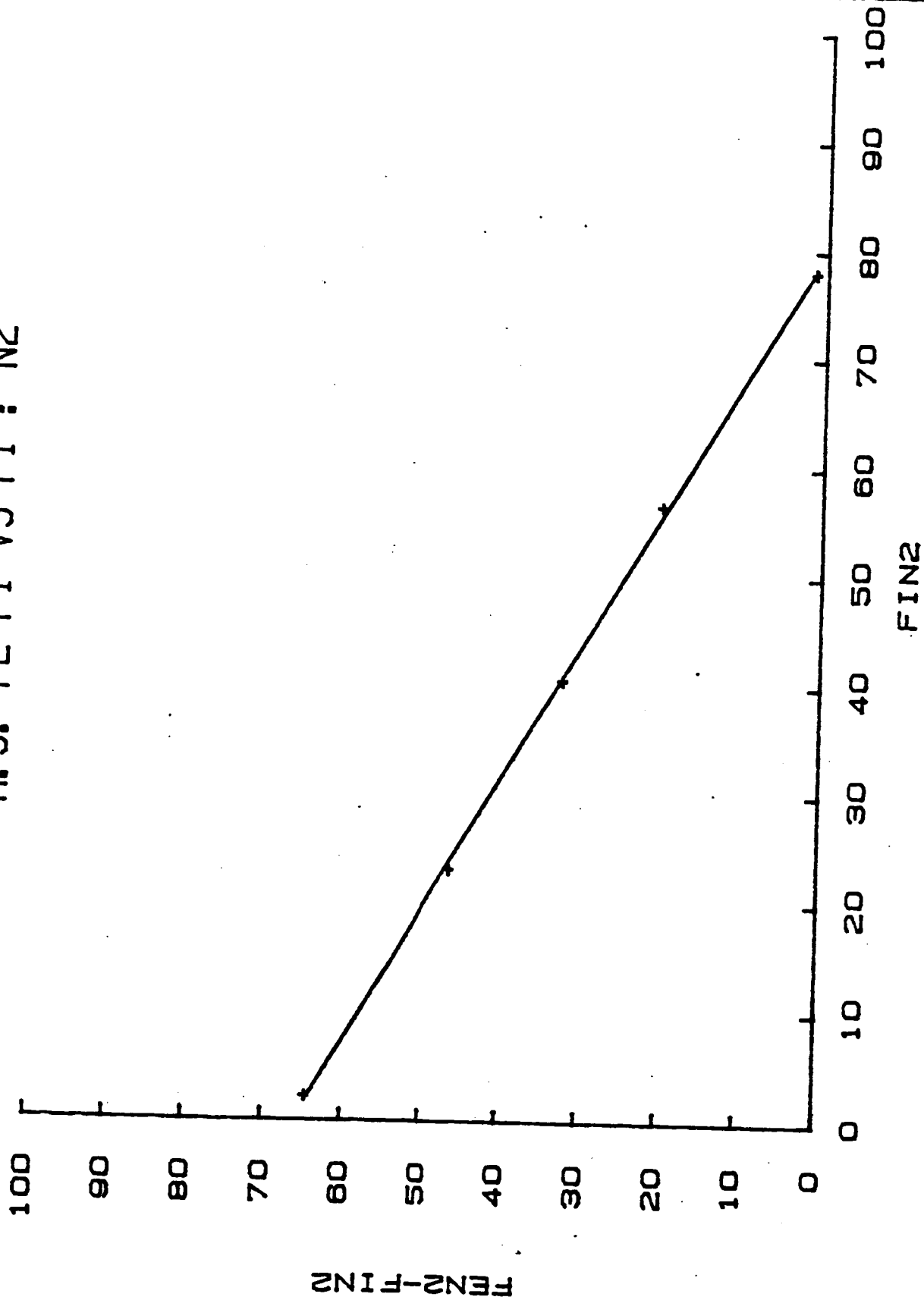

Figure 3.



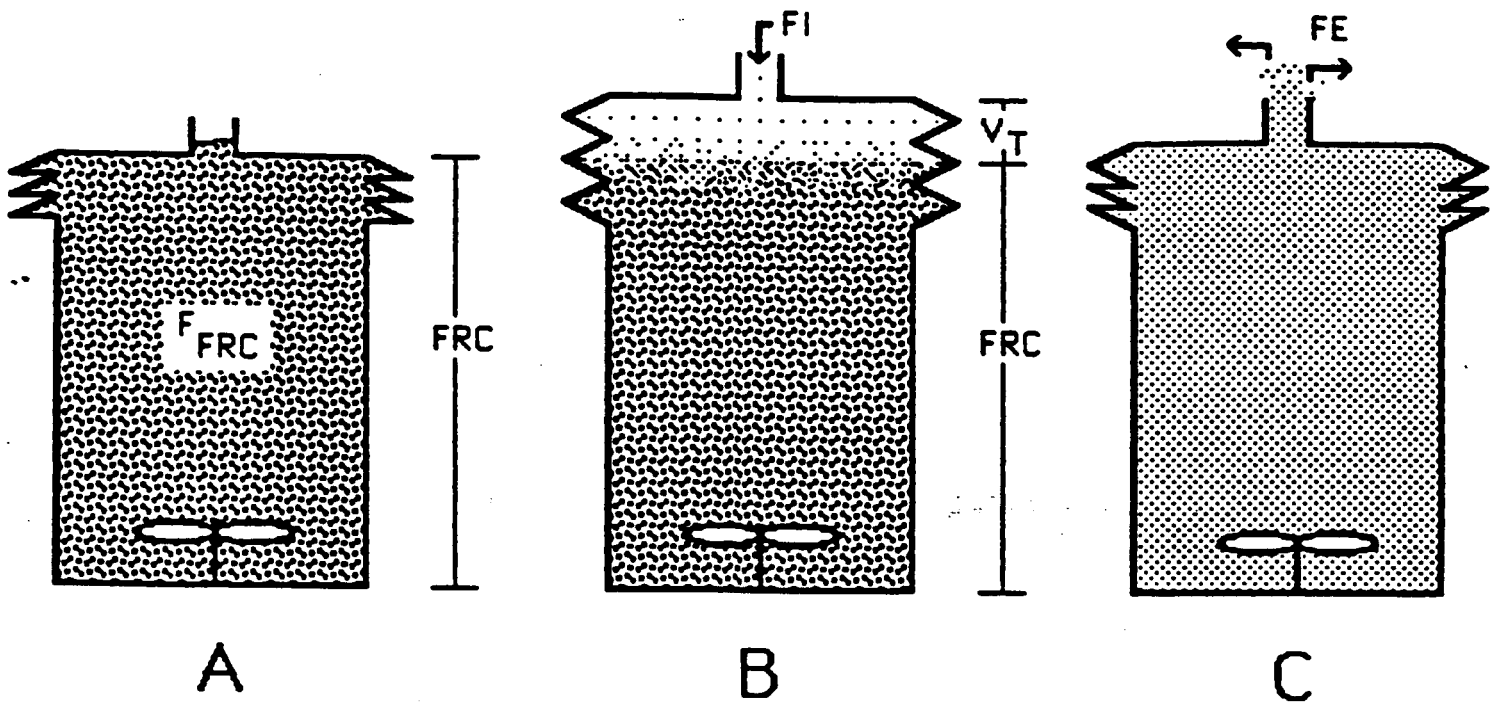

Figure 4. A. Illustration of a lung model whose volume is "FRC" and the gas concentration it contains is  $F_{FRC}$ .  
 B. The lung expands by volume  $V_T$  and takes in  $F_{FRC}$  concentration  $F_I$ .  
 C. These gases are instantly mixed (by the propeller) and the model exhales concentration  $F_E$ .

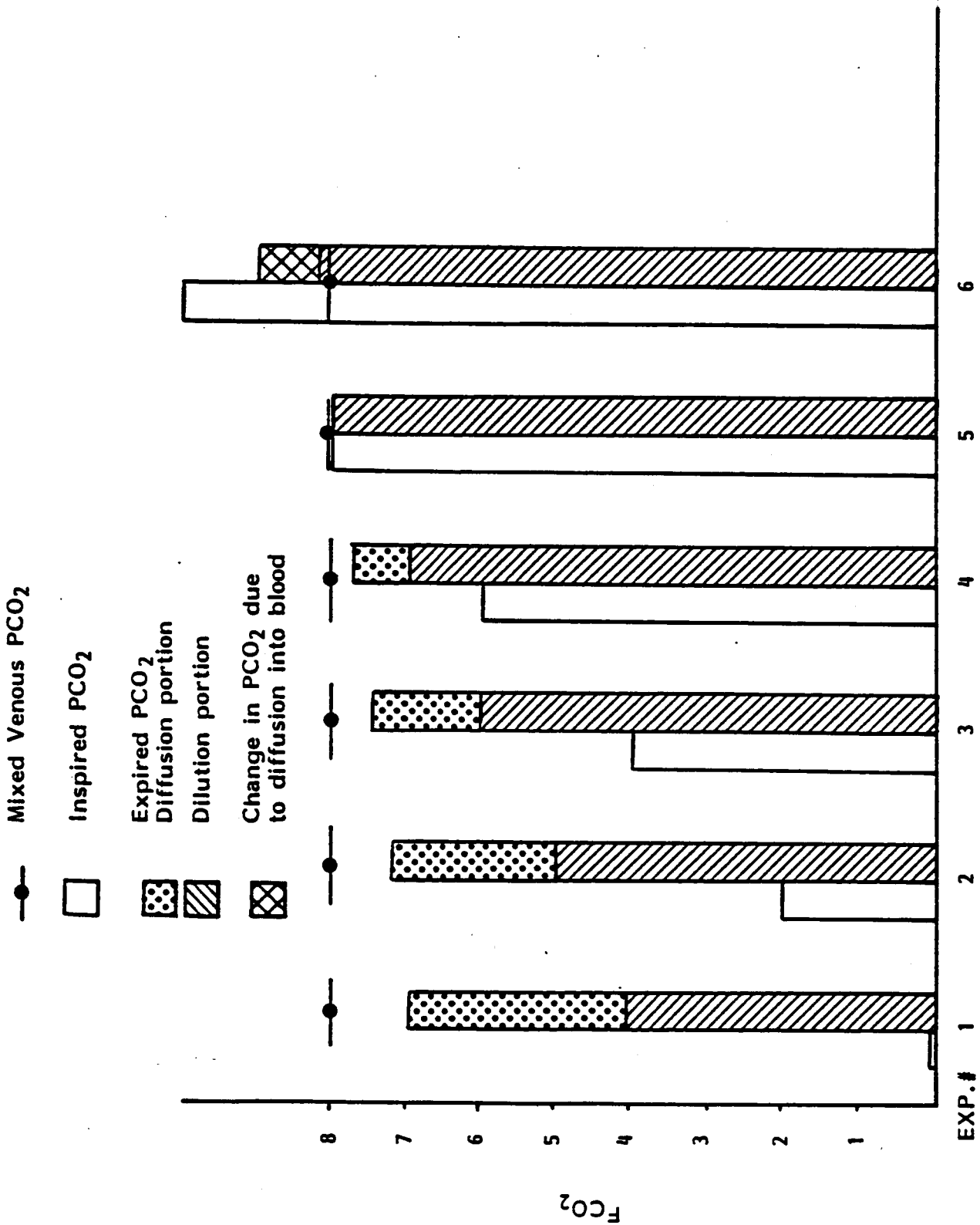

Figure 5. SCHEMATIC REPRESENTING THE RATIONALE USED FOR PREDICTING  $PVCO_2$

GRAPH DERIVED FROM SCHEMATIC

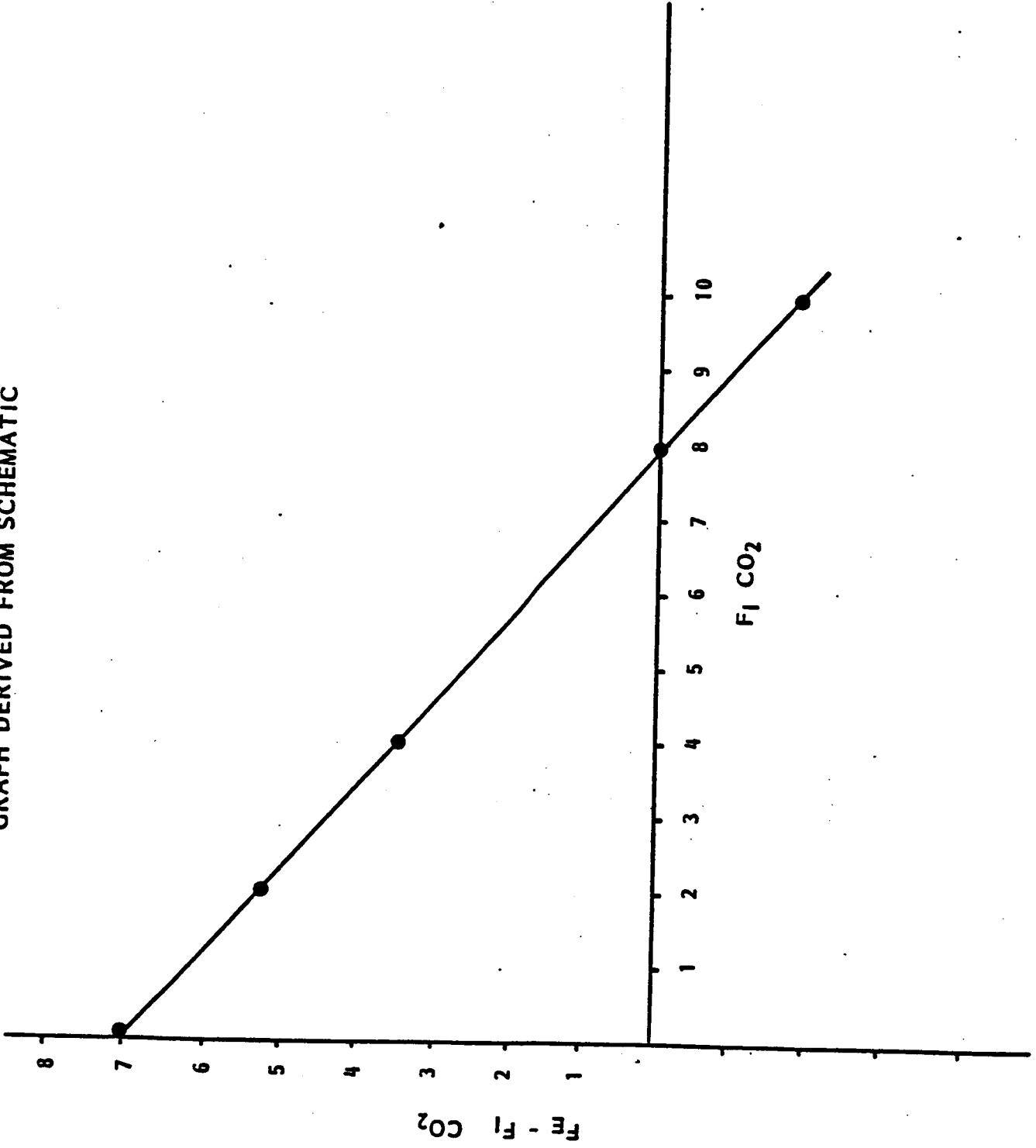

Figure 6.

FE-FI VS FI : CO2 (H.S)

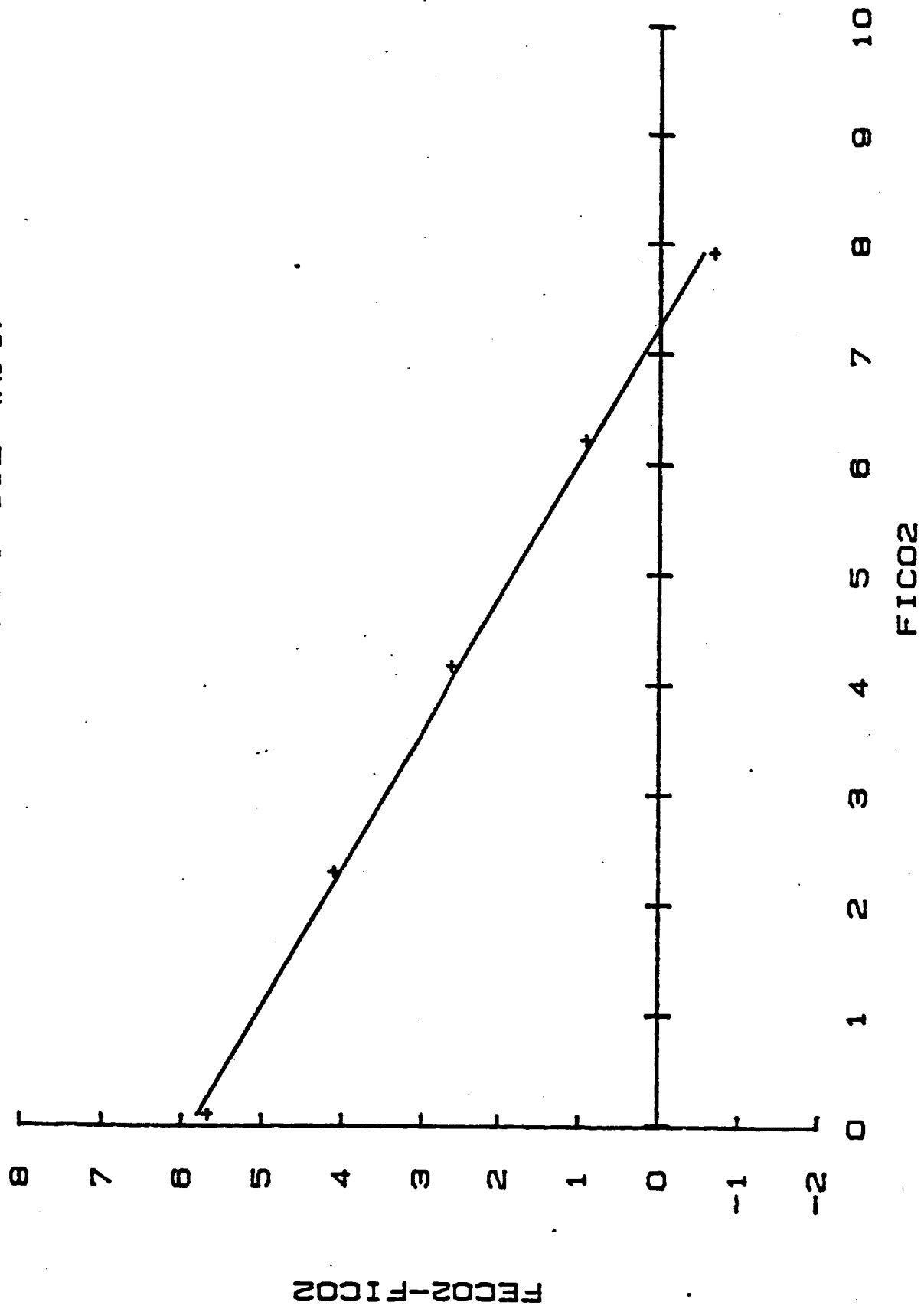

Figure 7.

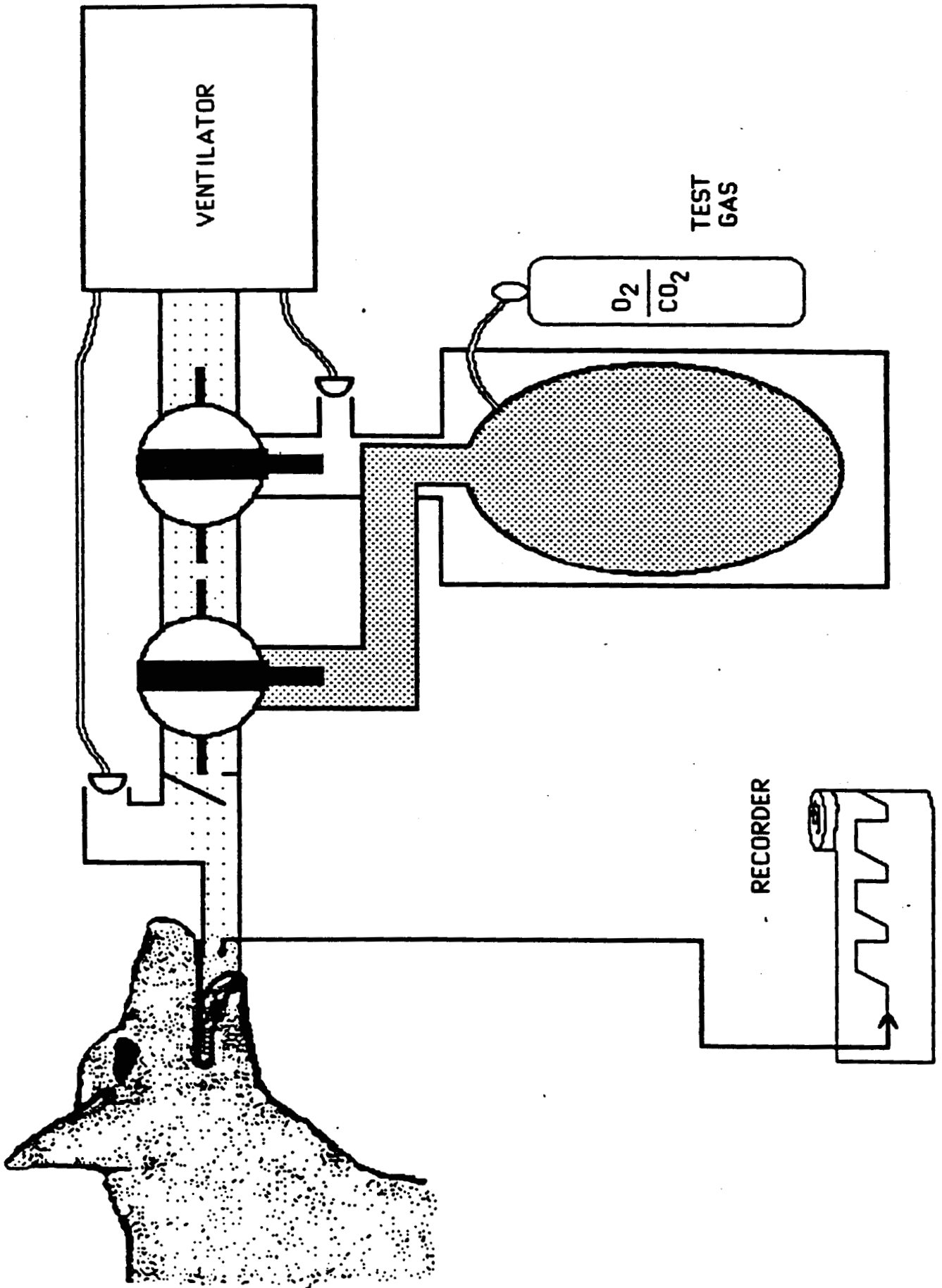

Figure 8. Schematic diagram of circuit used to ventilate dogs and apply the test gas. Control phase depicted.

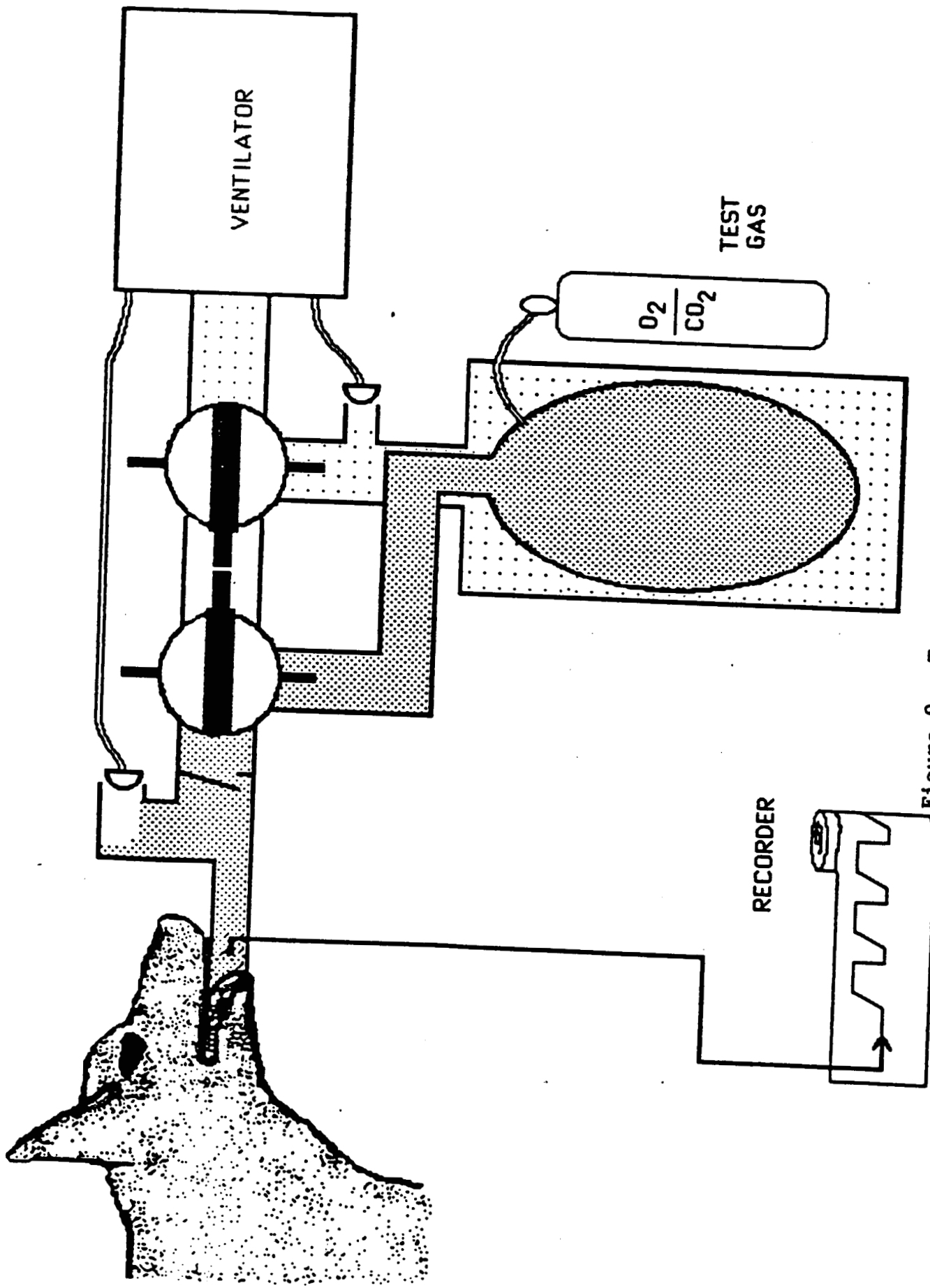

Figure 9. Test gas phase. Ventilator injects its volume into the bottle and displaces an equal volume of test gas from the bag.

# FECO2-FICO2 VS FICO2

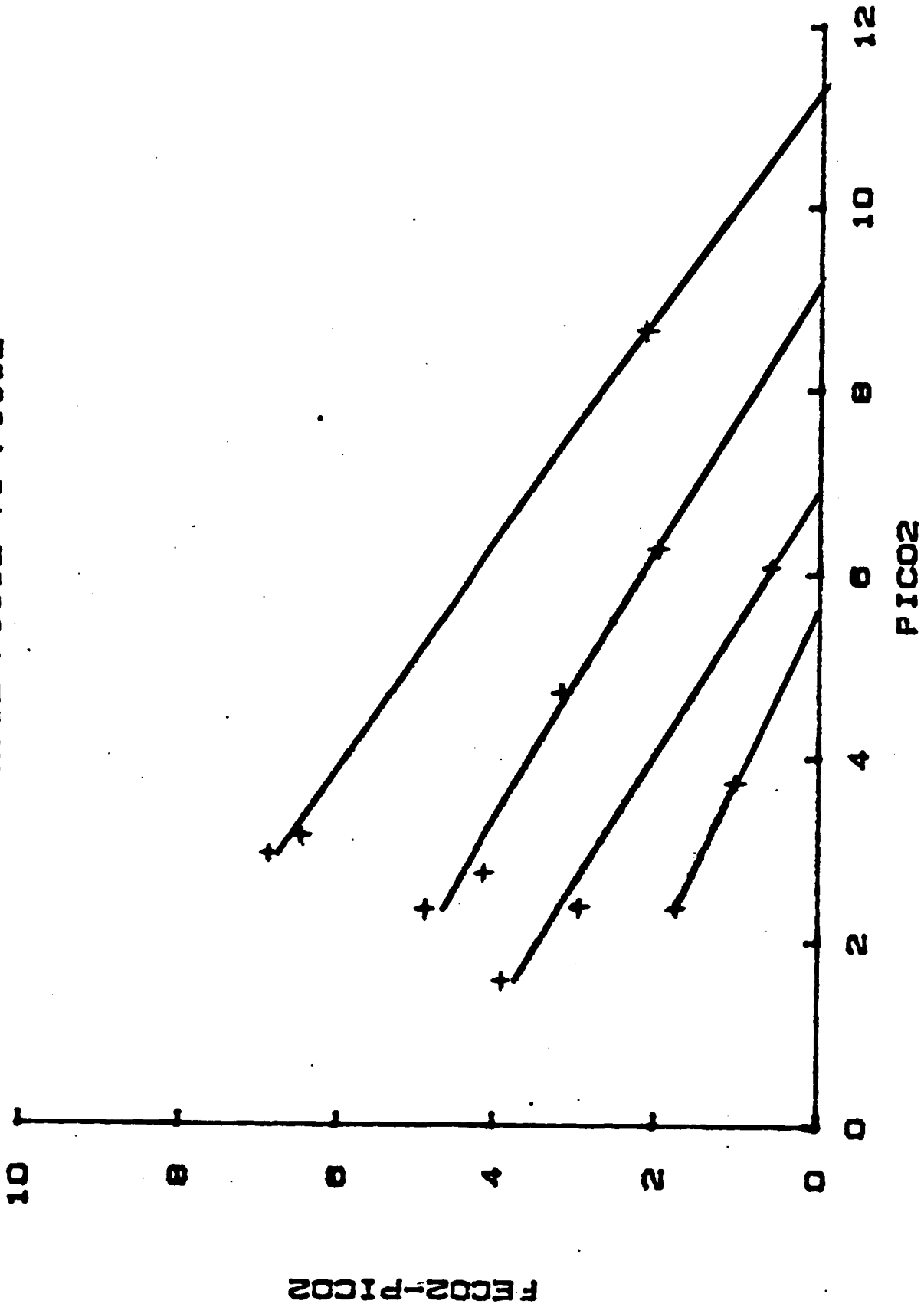

Figure 10.  $F_{E-FI}$  vs  $F_I$  values for one dog whose  $P_{vCO_2}$  was changed by altering frequency of the ventilator while keeping the tidal volume constant. Theoretical considerations would predict a series of parallel lines intersecting the abscissa at the mixed venous  $PCO_2$  values.

# NONINV. VS INVAS. PCO2

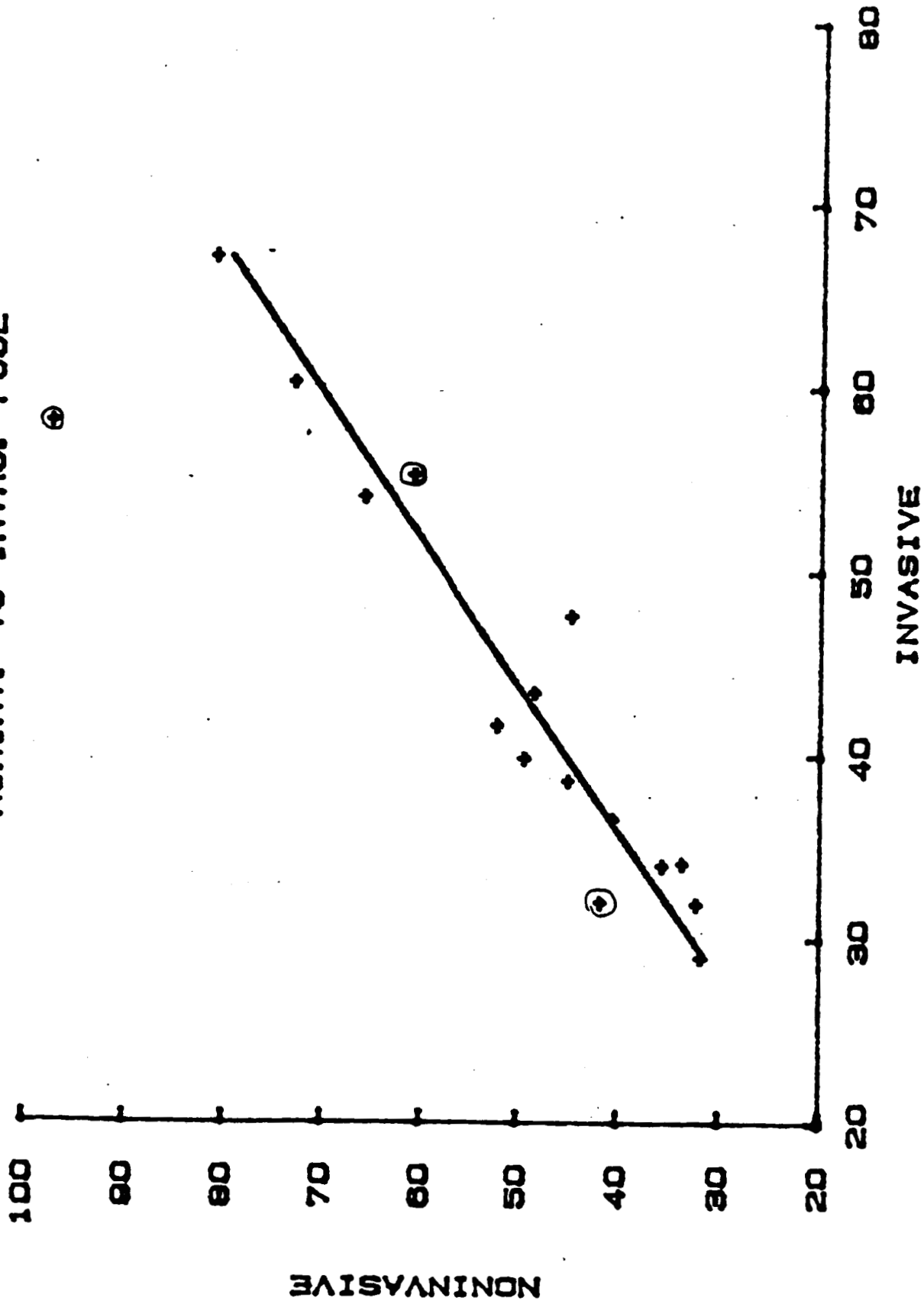

Figure 11. A plot of the value at intercept with the abscissa of lines as generated in Figure 10. Circled points were generated in the dog breathing spontaneously at various depths of anesthesia.



NON-INV. VS INV. CCO2

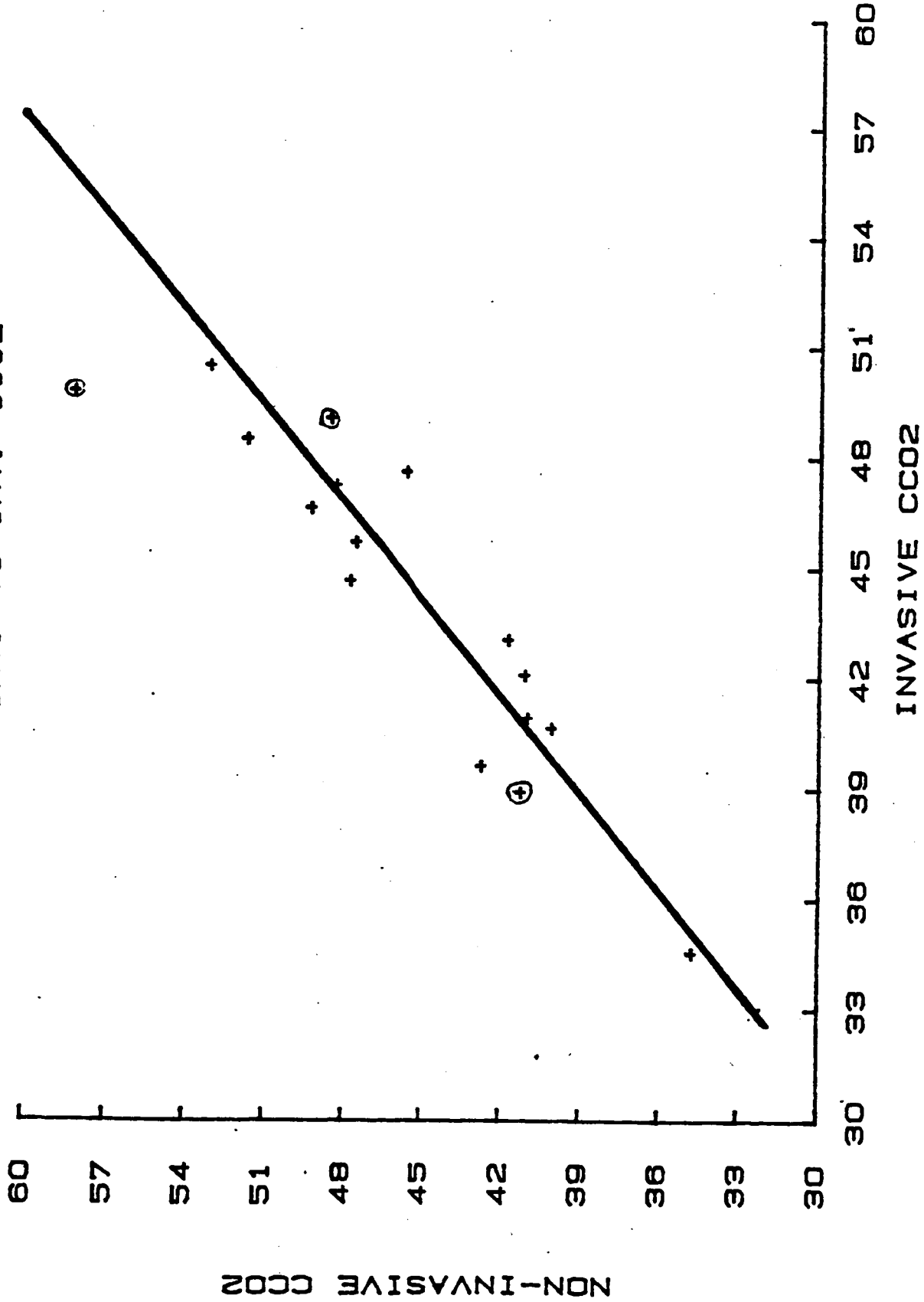

Figure 12. Carbon dioxide content as calculated using invasive and non invasive calculated PCO<sub>2</sub> are graphed. Circled points represent spontaneous ventilation.

# FISHER SYSTEM USERS MANUAL

## Startup Procedure

Refer to Figure 6.

1. Insure that gas tanks are attached and secured tightly.
2. Insert FISHER SYSTEM Program Disc into the disc drive and close the drive door.
3. Turn gases on. Second stage of the gas regulator should indicate approximately 5 PSI.
4. Insure that patient mouth port is sealed for the initial delay measurement.
5. Turn main power switch to ON position. The FISHER SYSTEM program will load itself and auxiliary subroutines. The program will start the delay measurement function ( see section on MAIN MENU) and upon completion, will return to the main menu.
6. Calibrate the Andros CO<sub>2</sub> Analyser as per instructions in the calibration section.

## Calibration of Andros CO<sub>2</sub> Analyser

The Andros CO<sub>2</sub> analyser must be calibrated after the system has been on for at least 10 minutes to allow for a stable operating temperature. To calibrate the meter, select option \*1 from the FISHER SYSTEM MENU. The monitoring display will appear on the screen ( figure 2 ) , showing continuous measurements of %CO<sub>2</sub> concentration and tidal volume both numerically and graphically.

## FISHER SYSTEM USERS MANUAL

### Zero Setting

To zero the signal, use the "ZERO" knob on the front panel (see figure 6) and observe the numerical % CO<sub>2</sub> display only. Turn the knob in the appropriate direction (UP indicated by "U", DOWN indicated by "D" on the front panel) until the meter reads some value slightly greater than 0% (for example 0.01%). This slight offset will not affect CO<sub>2</sub> measurements within the specifications of the analyser and is necessary for the following reason. The Andros analyser output signal, although nominally 0-10V, can give a signal at negative voltage for zeroing procedures when used with analog systems. The FISHER SYSTEM, however, digitizes this signal using an A/D converter for computer data acquisition and analysis. The A/D converter responds to positive voltages only. Thus, a reading of exactly zero on the monitoring screen may correspond to an offset (negative) signal of any amount, which would affect any subsequent CO<sub>2</sub> value measured.

### Span Setting

Once the zero has been set, test gas #1 is used to complete the two point calibration. (It is suggested that this procedure be carried out infrequently, as a sizable volume of gas is used.) **Insure that the patient port is closed for proper calibration.** Press "C" on the keyboard as per the instructions appearing on the monitor. The valves will open to let test gas #1 flush past the sampling port. Allow 15-20 seconds for the gas to flush out any gas that was in the tubing prior to calibration. Using the SPAN knob on the front panel, adjust the meter until the numeric display shows the concentration of test gas #1 (which may be read from

## FISHER SYSTEM USERS MANUAL

the cylinder). When this is set, press <RETURN> to turn off gas and return to the main menu.

### The FISHER SYSTEM MENU

The FISHER SYSTEM is "menu driven". This means that any one of its functions can be performed in any order desired (with some restrictions to be mentioned) or redone as often as desired, just by selecting the appropriate action from the menu. The main menu is a list of actions that may be performed by the system and is returned to at the end of each action. It appears on the screen as below.

#### FISHER SYSTEM MENU

- 1) CALIBRATE/MONITOR
- 2) COMPUTE DELAY
- 3) VCO<sub>2</sub>/VE/END TIDAL
- 4) TEST GAS #1 (OR TEST GAS #3)
- 5) TEST GAS #2 (OR TEST GAS #4)
- 6) PLOT E-1
- 7) CONVERT P/CCO<sub>2</sub> AND CARDIAC OUTPUT
- 8) CHANGE GASES TO 3 & 4 (OR 1 & 2)
- 9) RESTART
- 10) ARTERIAL PCO<sub>2</sub>

Some of the lines may be printed in inverse mode. These are the functions that have already been performed. Any one of these may be repeated, with the effect of replacing the data from the first measurement with that of

## FISHER SYSTEM USERS MANUAL

the second. A description of each function will now be given.

### 1. CALIBRATE/MONITOR

The calibration procedure has already been described. In addition, this may be used to monitor the patient's tidal volume and end tidal  $PCO_2$  to see if the patient is in a steady state.

### 2. COMPUTE DELAY

This function measures the inherent response delay of the Andros  $CO_2$  analyser due to the fact that the sample cell which performs the analysis is distal to the sampling port near the patient port. This is necessary for accurate computation of  $VCO_2$  by integration of the volume and  $CO_2$  waveforms. The volume measurements are transmitted to the computer electrically and are thus instantaneous. This function is performed automatically after power up of the system, to insure that the delay is measured. It can be remeasured by the user if the sampling flow rate for the Andros pump is changed.

**Before selecting this function, insure that the patient port is closed.** The system will fill bag #1 with test gas #1. The gas will then be flushed through the exhalation port. The system then calls a subroutine to measure the delay and returns to the main menu. **WARNING: SHOULD THE USER SELECT THIS FUNCTION WHILE THE PATIENT IS ATTACHED (VENTILATED), THE PROGRAM MUST BE TERMINATED TO PREVENT POSSIBLE INJURY. SEE SECTION ON TERMINATION FOR THE CORRECT PROCEDURE !!**

## FISHER SYSTEM USERS MANUAL

### 3. VCO<sub>2</sub>/VE/ END TIDAL

This function measures minute CO<sub>2</sub> production (VCO<sub>2</sub>), minute ventilation (VE), and end tidal PCO<sub>2</sub>. The screen monitor will appear after selection of this function. The system will record the volume and CO<sub>2</sub> data for 5\* breaths. A subroutine will be called to integrate the data for computation of VCO<sub>2</sub>. The CO<sub>2</sub> wave form will appear on the digitization screen. Use the following keys to move the pointer to the desired value for end tidal PCO<sub>2</sub>.

**H- cursor left, 5\* columns per key depression**

**J- cursor left, 1 column per key depression**

**L- cursor right, 5\* columns per key depression**

**K- cursor right, 1 column per key depression**

The numerical value of PCO<sub>2</sub> will be shown on the screen. Once the desired value for PCO<sub>2</sub> is pointed to by the cursor, **press <I> to select the value** and proceed. The digitization process is repeated so that another end tidal PCO<sub>2</sub> value may be chosen (from a different breath). The reason for this is that there is a small fluctuation in end tidal PCO<sub>2</sub> over successive breaths. Both these values will be used in determining PvCO<sub>2</sub>.

\*see section on changeable program parameters

### 4. TEST GAS #1 ( or TEST GAS #3)

## FISHER SYSTEM USERS MANUAL

This function administers test gas #1 (or #3) to the patient and allows selection of the  $F_I$  and  $F_E$  values by the user. Upon selection of this function, the monitor screen will appear. The system will fill bag #1 with the test gas. Excess gas is used to flush any gas remaining in the tubes connecting the bag to the patient via the green "pop-off" valve located near the patient manifold (see figure 1). This insures a constant inspired concentration of gas. Once the bag is full, the system waits for the patient to expire.

Upon expiration, the valves are opened so that the patient inspires from the reservoir bag of test gas. Due to the limited size of the bag, the system must intermittently pulse gas into the bag, while the patient is exhaling. In order to do this, the system measures the time taken for the patient's last exhalation and fills the bag for a fraction of this time. During the refilling, however, the patient cannot inspire as the inspiratory limb is occluded to prevent the filling gas from flowing past the sampling port (see section on Changeable Parameters for information on Frequency Response). Since only three breaths of the test gas are given, the maximum tidal volume allowable should be  $\approx 600$  cc.

After the test gas is administered, the valves are turned so that the patient is breathing room air. The digitization screen (see figures 3 and 4) will appear with the  $CO_2$  data from the test. The user should use the cursor (see cursor instructions in previous section) to select  $F_I$  where the inspired concentration is constant. This concentration should be roughly equal to the concentration on the gas tank but not necessarily exactly equal to this number due to possible mixing of the test gas with gas from

## FISHER SYSTEM USERS MANUAL

the tubing prior to the test. Once  $F_I$  is selected, use the cursor to select  $F_E$  from the third breath. This should be the maximum value of the expired wave for  $F_E > F_I$  (see figure 3) or the minimum value of the wave for  $F_E < F_I$  (see figure 4). When this is completed, the system will return to the main menu.

### 5. TEST GAS \*2 (or TEST GAS \*4)

This function administers test gas\*2 (or 4) to the patient exactly as described previously with test gas \*1.

### 6. PLOT E-I

This function computes the regression statistics for the  $F_E - F_I$  vs  $F_I$  line to determine  $P_vCO_2$  from the x-intercept. The slope, correlation coefficient and  $P_vCO_2$  values will be displayed, followed by a graph of the regression line. Press <RETURN> to return to the main menu when finished viewing graph. NOTE: This function may be performed only after measuring end tidal  $PCO_2$  and administering 2 or 4 test gases.

### 7. CONVERT P/CCO2

This function calls a subroutine to convert  $PCO_2$  to  $CCO_2$  (by Olszowka et. al. 1982). The user must enter the following patient parameters: base excess (if known) or pH, hemoglobin,  $PO_2$ , and temperature. The  $CO_2$  content and  $O_2$  content of the mixed venous blood will be printed on the screen. This function must not be selected until the plotting function has



## FISHER SYSTEM USERS MANUAL

been selected.

### 8. CHANGE GASES TO 3 & 4

This function allows the user to add two test gases to the system for a five point determination of  $PvCO_2$ . Gas tanks must be changed by the user. The main menu reflects the change. Once selected, the plotting function may not be selected until both of these gases have been administered at least once.

### 9. RESTART

This function erases all patient data. Calibration procedure and delay measurement need not be repeated at this time.

### Termination of Program

Should the program at any time need to be terminated by the user while performing any of the system functions (i.e. not in the main menu mode), the following procedure should be followed for ventilated patients. Press <CONTROL> and <RESET> buttons on the APPLE keyboard simultaneously. This terminates the program and resets all valves to the off position as indicated by the front panel LEDs being off. **Using the manual override switches on the front panel (figure 5), turn BV4 and BV5 to the ON position.** This insures that the ventilator volume will be delivered directly to the patient.

### Changeable Program Parameters

As this version of the FISHER SYSTEM and its software are prototypes

## FISHER SYSTEM USERS MANUAL

only, certain features of the system as well as program parameters were left manipulable for testing and development purposes. The following is a list of variables which may be changed as the user sees necessary, with explanations of the parameters and the line numbers where they should be changed.

1. MEMORY LOCATION 4105 - the contents of this location is an indicator of the frequency response of the system for volume measurements in the following way. The routine which detects end of expiration counts the time for which the propellor in the flow meter does not turn and matches it against this number. The higher this number, the greater is the confidence that a true end expiration has been detected. The lower this number, the faster is the detection and phase change flag (respiratory phase is indicated on the monitor screen beside the word EXPIRING. A 1 indicates expiration, a 0 indicates inspiration. See Figure 2.)

The system initializes this value to 60 on line number 1140. This may be raised or lowered by the user.

2. Eliminate Gas Pulsing - the gas pulsing to refill the bag with test gas between breaths may be eliminated for suitable tidal volumes and respiratory frequencies. To do this, insert as line 4144 the following:

```
4144 GOTO 4160
```

3. B1 - this variable is the number of breaths used in the measurement of  $VCO_2$  and end tidal  $PCO_2$ . The maximum number of breaths allowable by the memory size is 8 ( minimum is 1 ). A more accurate  $VCO_2$  is measured with more breaths, and this also allows better

## FISHER SYSTEM USERS MANUAL

determination of end tidal  $PCO_2$  since there are more to values to choose from. The system sets this variable to 5 initially on line 7025. This may be changed by the user.

3. Cursor speed - change 5 on lines 4485 and 4495 to a higher number (<10) for faster movement.

### Performing the Test

To perform the test to determine  $PvCO_2$ , the following functions must be performed at least once. Before starting the user should select

#### 9) RESTART

to insure that old patient data is erased. Once this is done, the following should be performed in any order.

#### 3) $VCO_2/VE/END$ TIDAL

#### 4) TEST GAS #1 (OR TEST GAS #3)

#### 5) TEST GAS #2 (OR TEST GAS #4)

Once these have been performed, repetition of any of these functions is optional. In addition, for greater accuracy, the user may want to obtain additional data by attaching two additional gases. This may be performed by selecting

#### 8) CHANGE GASES TO 3 & 4

attaching the gases and then performing

#### 4) TEST GAS #3

#### 5) TEST GAS #4

## FISHER SYSTEM USERS MANUAL

Once all of the data points have been obtained, the user should select

### 6) PLOT E-1

to determine  $PvCO_2$ . Should the user require  $CvCO_2$  for determination of cardiac output, the user should first select

### 10) ARTERIAL $PCO_2$

and then select

### 7) CONVERT P/ $CCO_2$ AND CARDIAC OUTPUT

For further information about each function see the section on the MAIN MENU.

## Trouble Shooting

The following is a list of possible problems that may be encountered with the system and the appropriate corrective actions which should be taken.

1. All front panel lights on simultaneously - +5V supply fuse has blown. Turn power off. Replace (see figure 6) with **MDL 250V/ 2.5 A** fuse.
2. Patient has difficulty breathing test gas - patient may be trying to breathe against closed valve due to pulsing. Patient may decrease respiratory rate or pulsing may be omitted. Frequency response may be adjusted (see section on Changeable Parameters).
3. Error messages when converting P/ $CCO_2$  - entered parameters out of range . insure that all requirements of a minimum test have been performed including Plotting. Reselect this function. Check that entered parameters are correct.
4. Inspired test gas concentration not constant- check gas system for

## FISHER SYSTEM USERS MANUAL

leaks including ballon valves. These may be tested by opening and closing using the manual switches on the front panel.

# System Schematic

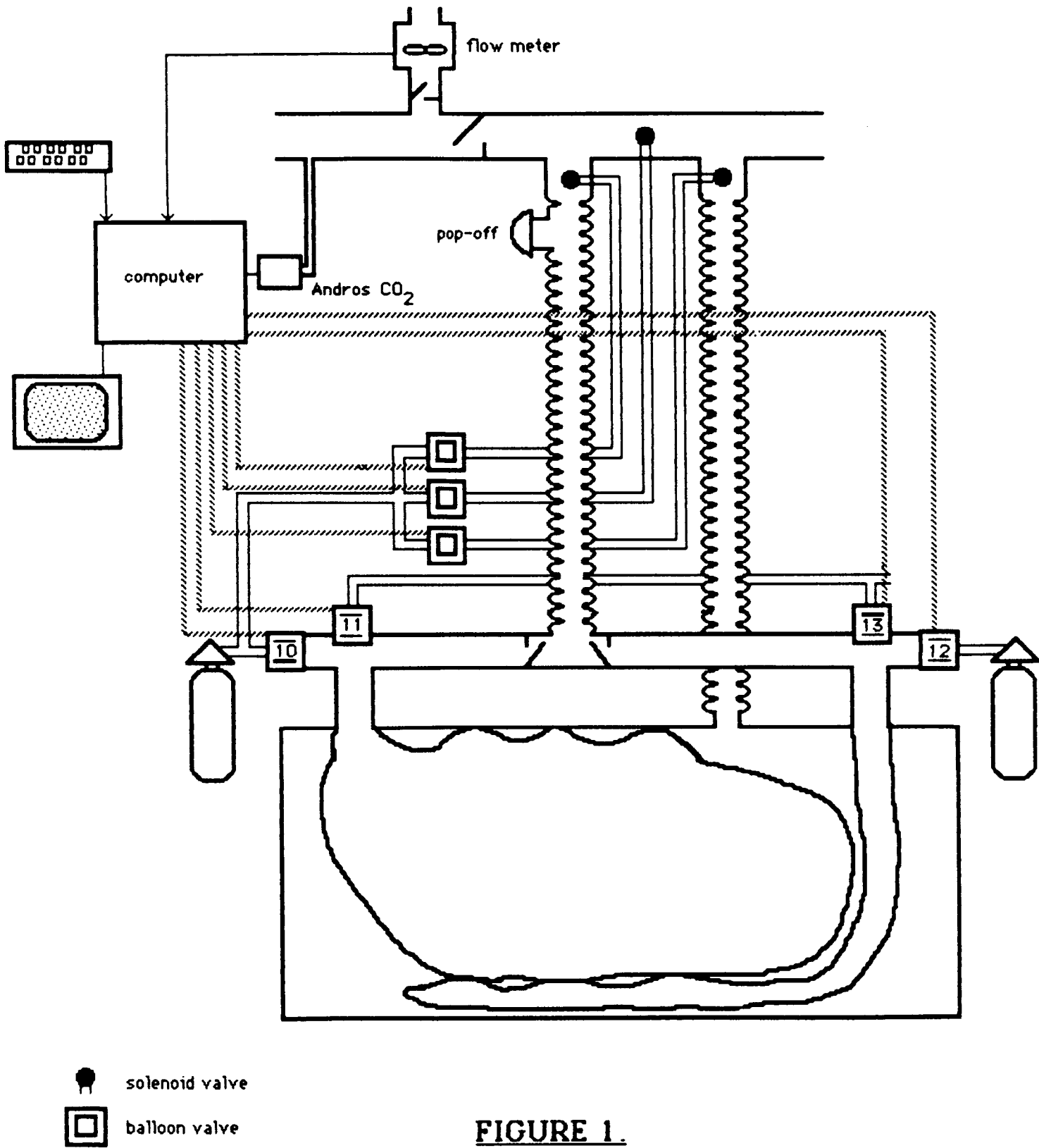

**FIGURE 1.**

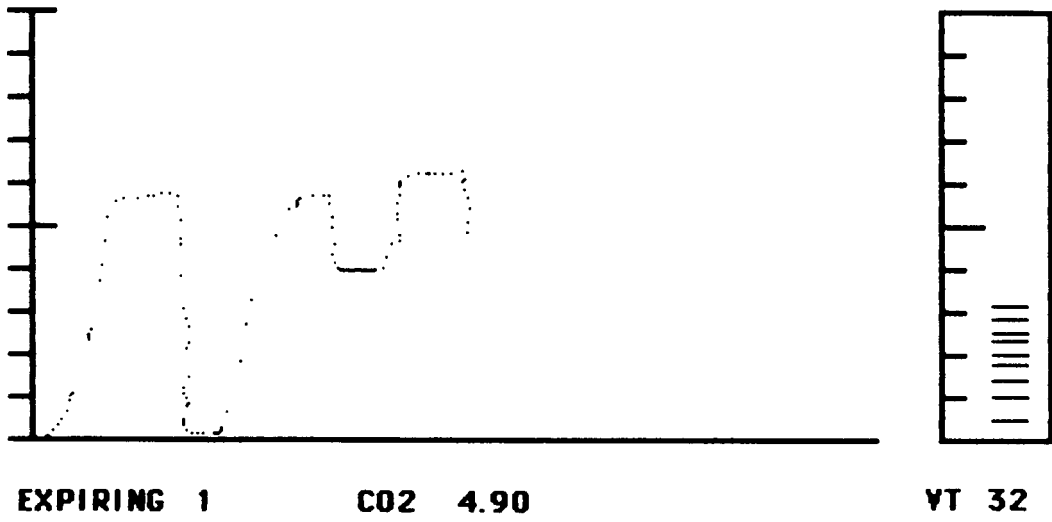

**FIGURE 2. DISPLAY SCREEN**

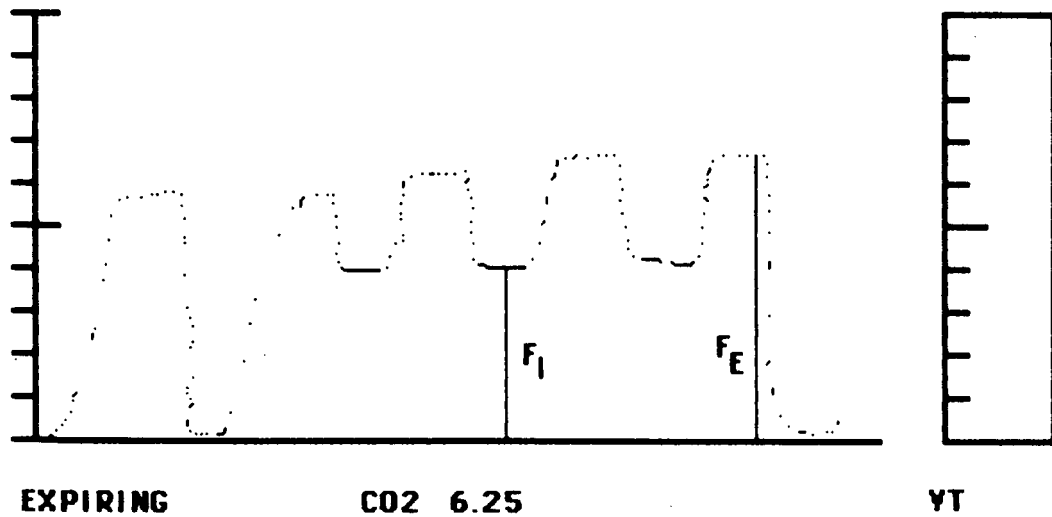

**FIGURE 3. DIGITIZATION SCREEN**  
**(F<sub>E</sub> > F<sub>I</sub>)**

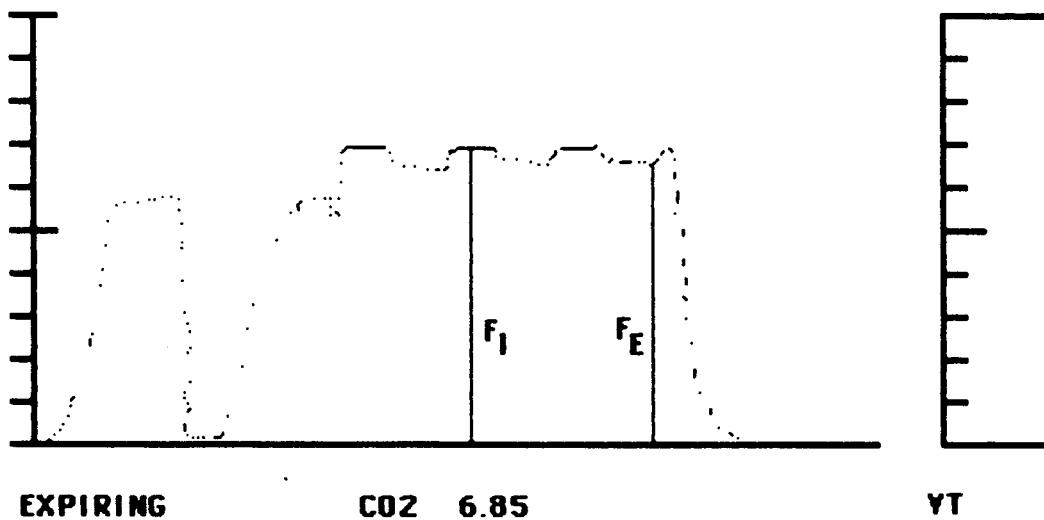

**FIGURE 4. DIGITIZATION SCREEN**  
**( $FE < FI$ )**

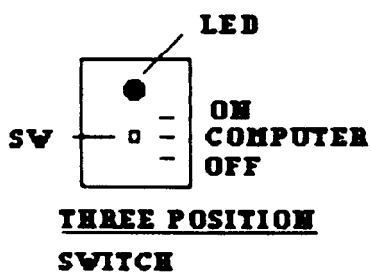

**THREE POSITION SWITCH**

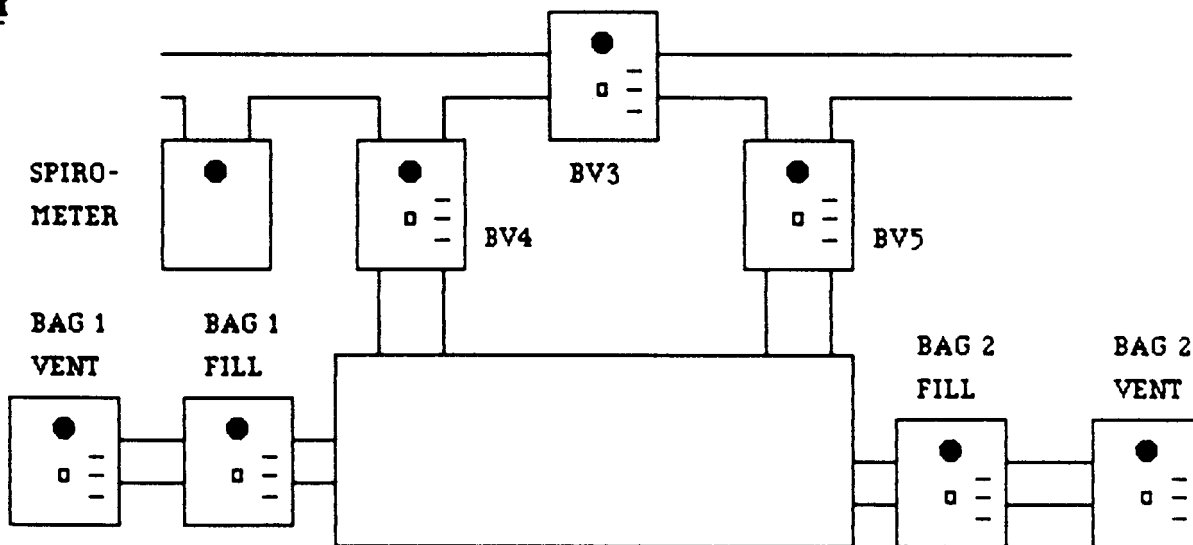

**FIGURE 5. FRONT PANEL INDICATORS AND SWITCHES**



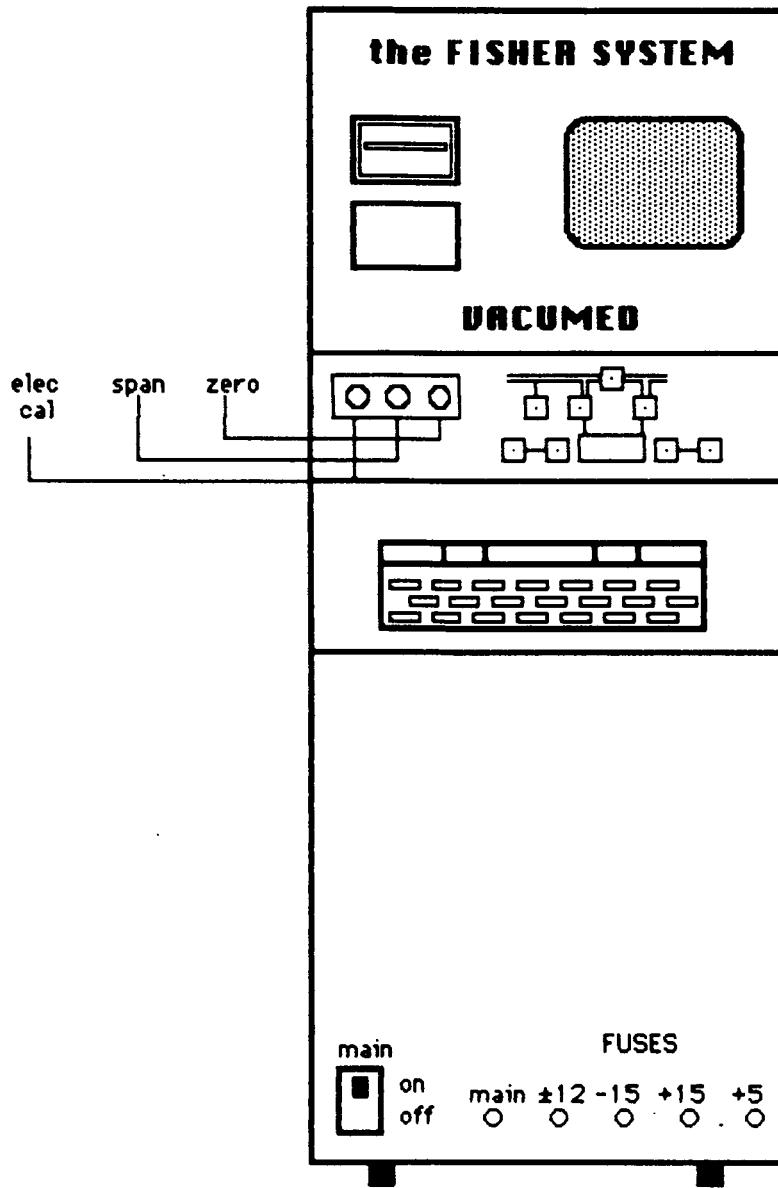

**FIGURE 6. THE FISHER SYSTEM**

### FLOW TRANSDUCER MAINTENANCE

The Kozak Modular Flow Transducer SC-520 consists of the flow transducer body and a removable SC-521 turbine cartridge. All SC-521 cartridges are interchangeable. We recommend you keep a spare cartridge on hand. The transducer body comprises the infrared opto-electronics, and is not submersible. All the cartridges are shock proof, immersible, and sterilizable. Moisture, condensed vapor, or saliva expelled by the patient will not affect the operation or accuracy of the flow transducer. It will provide long and reliable service if regularly cleaned by rinsing the cartridge in water after use, or cold chemical sterilization to prevent the drying-out and hardening of the saliva or disinfectant deposits inside the turbine cartridge.

To remove the cartridge from the transducer body for inspection or cleaning, simply apply moderate axial pressure to the black rear part of the cartridge, and it will pop out easily. Secure the white front end of the cartridge with the other hand to prevent the cartridge from dropping on the floor while removing it. NEVER clean the cartridge by using a cue tip or similar cleaning probe inserted into the turbine cartridge, as this will damage the turbine blade and/or the pivot assembly. ALWAYS keep the transducer clean and use the proper disposable mouthpieces, such as the VACUMED #1026. Improper mouthpieces may cause air leakage, or may not otherwise work properly. To clean the transducer body, use a lint free dry cloth, and do not apply any pressure to the optical lenses inside the body. Always keep it dry.

The accuracy of the SC-520 flow transducer is given only by the mechanical dimensions of the turbine and the impeller. Because the dimensions are constant and consistent, (precision production technology and components), calibration or recalibration is not needed. The operation of the transducer is strictly digital. It transmits electric pulses and the pulses are counted as volume increments. This is the principle of 100% drift free operation and long term stability. The only and essential condition for consistent accuracy is the proper function of the impeller, i.e., its unobstructed rotation capabilities. Therefore, a very simple test of flow rotation sensitivity is a reliable accuracy indicator. The electronic components of the flow transducer - the infrared emitter and the photo transistor - do not have any influence on the accuracy. Any malfunction of the opto-electronic system will result in loss of the electric output signal.

SENSITIVITY TEST: Take the turbine cartridge in your hand so that you are facing the rear black end of the cartridge. Start walking with a speed of about half to one mile per hour, watching the impeller rotate inside the cartridge. If the impeller does not rotate freely, it indicates a malfunction of the jewel bearing suspension system, caused mainly by the saliva deposit buildups as a result of insufficient maintenance. In such a case, the cartridge should be immersed in water for a few hours, and then rinsed to remove dissolved deposits. The most efficient rinsing method is to apply a moderate stream of water into the cartridge input opening (the white end) directly from the water tap. If any malfunction persists, the turbine cartridge should either be sent to the factory for inspection, or replaced.

(Ref: E/FLOWTRAN)

FISHER SYSTEM DOCUMENTATION

<u>ITEM</u>	<u>Description</u>	<u>Drawing No.</u>	<u>Page</u>
1.	Bill of Material	-----	A 1 & 2
2.	List of Standard Commercial Components	-----	A 3
3.	Block Diagram	1147-6	A 4
4.	Interconnection Diagram	1147-7	A 5
5.	Valve Driver Interface	1147-8	A 6
6.	VDAS Computer Interface	1147-9	A 7
7.	Turbine Electronics Schematic	1147-10	A 8
8.	Turbine Electronics Parts List	-----	A 9
9.	Apple Interface Schematic	1147-11	A 10
10.	Gas Valve System Schematic	1147-3	A 11
11.	Patient Interface, Block Diagram	Fig 1	A 12

DATE 04/22/86

BILL OF MATERIALS

ORIGINAL PAGE IS  
OF POOR QUALITYPART NUMBER: 7200  
DESCRIPTION: THE FISHER SYSTEM

LN#	PART NUMBER	DESCRIPTION	QTY
1	X7200-01	PATIENT MANIFOLD	1
2	X7200-03	BAG CYLINDER	1
3	X7200-04	VALVE V9	1
4	X50401	VDAS PCB POPULATED	1
5	.01021	STRIP PRINTER	1
6	.01022	EXTENDER CARD-VECTOR 3690	1
7	.04001	CIRCUIT BKR 20A 2 POLE	1
8	.07003	HOSP GRADE LINECORD	1
9	.08190	VERTICAL CABINET	1
10	.08191	SIDE PANEL KIT	1
11	.08192	SET OF 4 CASTERS	1
12	.08193	CABINET SHELF	1
13	.08194	REAR DOOR	1
14	.08195	INTERFACE CABINET	1
15	.08200	CARD CAGE	1
16	.09005	PCB EDGE CONN 22-44 SE	1
17	.09006	HOSP GRADE AC PLUG	1
18	.09051	CONN TURBINE CHASS 2-PIN	1
19	.09056	AC RECEPTACLE, ROUND SOLE	1
20	.13002	TURBINE MCT CHIP PC BOARD	1
21	.13003	CO2 ANALYZER MODULE	1
22	.14006	FUSEHOLDER 1/2"	1
23	.17001	LED MOUNT LHM-200	1
24	.17002	B BASE SUPPORT BRACKET	1
25	.17003	FEEDTHRU 1/8" PANEL MOUNT	1
26	.17948	AIR FUME MOUNTING BRACKET	1
27	.18900	DRAWER SLIDES (DISCONT)	1
28	.18901	BLANK MONITOR/DEFIVE PANEL	1
29	.18902	VISTA ANALYZER BOX	1
30	.18904	BASEPLATE W CASE CUTOUT	1
31	.18905	CARDCAGE ADAPTER BRACKET	1
32	.18906	DRAWER SHELF	1
33	.19001	TWIN TUBE BODY	1
34	.19002	TWIN TUBE INSERT	1
35	.19003	BODY PANEL MOUNTING	1
36	.19004	INSERT	1
37	.19006	FISHER VALVE MANIFOLD	1
38	.19008	HOSE FITTING FOR 1/8" ID	1
39	.19010	HOSE BARS FOR 1/16" ID	1
40	.22009	30 SN-7417	1
41	.22073	FLOWMETER .15 TO 1 LPM	1
42	.22076	FLOWMETER INSERT	1
43	.29013	ELECTRIC OUTLET STRIP	1
44	.29017	MARKER BOARD	1
45	.29025	TUBING FEEDTHRU 7/8" OD	1
46	.29046	TUBING SUPPORT ARM	1
47	.32001	M W DIP FLUORBOARD 3677-2	1
48	.34004	POWER SUPPLY +/-15V, +5V	1
49	.34005	POWER SUPPLY 12V (FISHER)	1

DATE 04/22/86

BILL OF MATERIALS

PART NUMBER: 7200

DESCRIPTION: THE FISHER SYSTEM

LN#	PART NUMBER	DESCRIPTION	QTY
50	.35001	IWAKI AIR PUMP	1
51	.44004	VAR RESISTOR 10K 10T	2
52	.44021	POT 50K TRIM 22T FRONT	1
53	.48002	SWITCH TOGGLE SPDT	2
54	.40103	LENS CAP, WHT, PWR SWITCH	1
55	.49014	14-PIN IC SOCKET	1
56	.62002	PLASTIC HOSE 1/16" ID BLK	10
57	.66001	PRESSURE RELIEF VALVE	1
58	.66002	VALVE 3-WAY SOLENOID 12V	1
59	.69040	TUBING PLAST 1/400 3/16ID	20
60	1049	SILICON TUBING, 20 FT.	1
61	1125	3-L BR, 5AG NIP WIOT TUBE	2
62	1467	COUPLER, 22mm OD, 15mm ID	1
63	1469	SILICON CONNECTOR 22MM	2
64	21501	DISP DESICCATOR COLUMN	2
65	50417	PRINTER EPSON LX-80	1
66	50427	PRASO PRINTER INTERFACE	1
67	50429	REAL TIME CLOCK (MTN NEW)	1
68	50429	SINGLE DISK DRIVE (APPLE)	1
69	50448	TRACTOR FEED EPSON LX-80	1
70	50456	RELAY DRIVER, ELECT-MECH	1
71	50500	APPLE//2 64K COMPUTER	1
72	50506	APPLE CRT CABLE	1
73	50519	9" AMBER MONITOR	1
74	5312	CLEAN-BOR TUBE 12"	2
75	5348	CLEAN-BOR TUBE 18"	1
76	5350	CLEAN-BOR TUBE 30"	1
77	5C-520	CONPL FLOW SENSOR	1

ORIGINAL PAGE IS  
OF POOR QUALITY

FISHER SYSTEM MAJOR COMPONENTS

Component System	Vacumetrics Part No.	Vendor/Address	Vendor Part No.
CO2 Analyzer	.13003	Andros 2332 Fourth St., Berkeley, CA 94710	10606
Computer	50500	Apple 904 Caribbean Dr., Sunnyvale, CA 94086	Apple //e A252064
Diskdrive	50429	Apple 904 Caribbean Dr., Sunnyvale, CA 94086	A2M1044
CRT Monitor	50519	Charlie Apple 2377 E. Main St., Ventura, CA 93003	SANSON
Printer	50417	Bell Industries 1829A De Havilland Dr., Thousand Oaks CA 91320	EPSON LX-80
Valve Manifold	.19006	Clayton Controls 2925 College Ave., Costa Mesa, CA 92626	MACK-12
Turbine Flow Sensor	SC-520	KL Engineering 13000-6 San Fernando Rd., Sylmar, CA 91342	SC-520
Turbine Electronics	.13002	KL Engineering 13000-6 San Fernando Rd., Sylmar, CA 91342	S-310
Computer Interface	X50401	Vacumetrics, Inc. Drawing No. 1147-9	N/A
Valve Driver	50456	Vacumetrics, Inc. Drawing No. 1147-8	N/A
GP Apple Interface Board	Part of X50401	Vacumetrics, Inc. Drawing No. 1147-11	N/A
Patient Manifold	X7200-01	Hans Rudolph Inc. 7200 Wyandotte St., Kansas City, MO 64114	112260
Power Supply +/-15V, +5V	.34004	Power One, Inc. 751 E. Daily Dr., Camarillo, CA 93010	HDCC-150W-A
Power Supply 12V	.34005	Power One, Inc. 751 E. Daily Dr., Camarillo, CA 93010	HE12-10.2-A

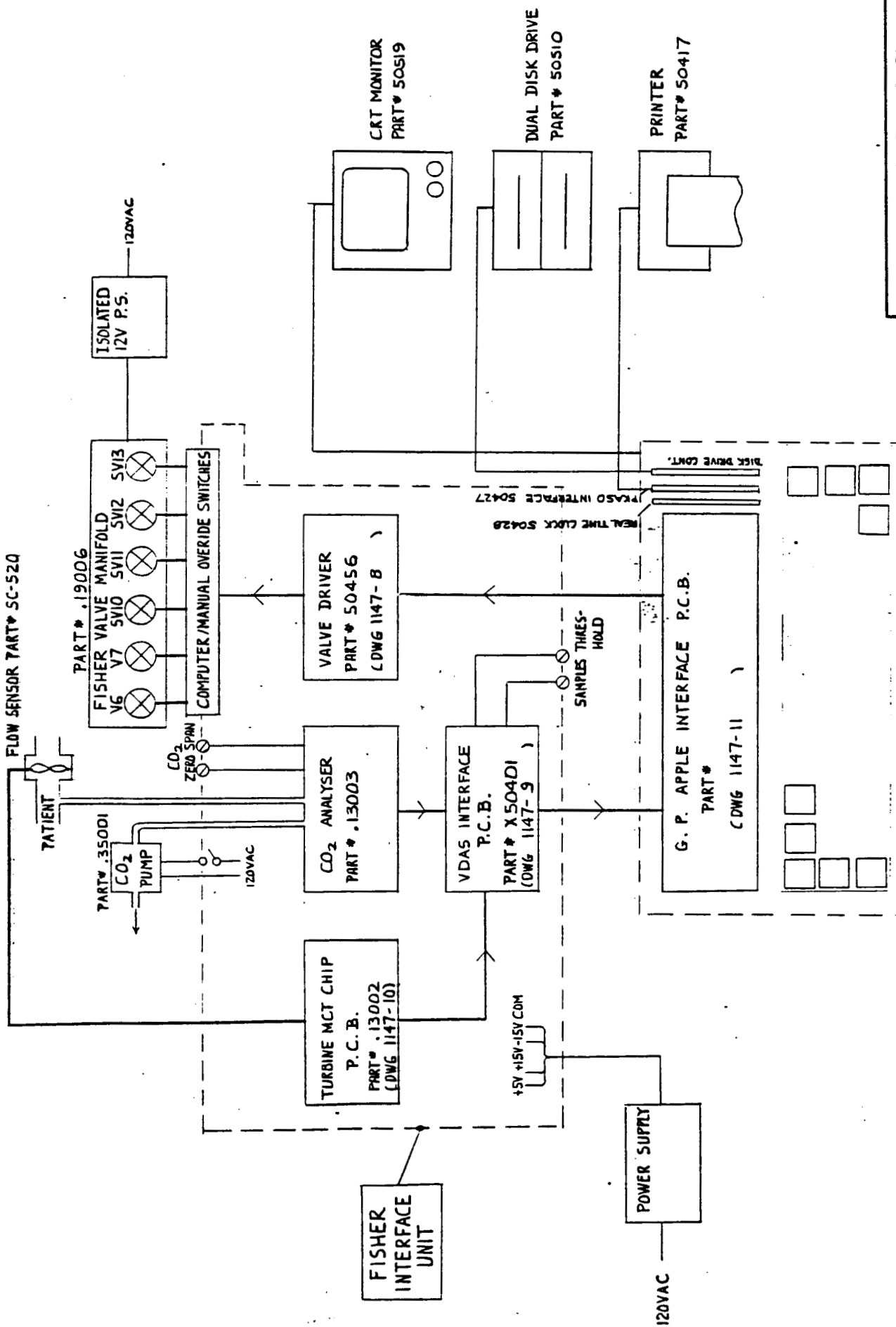

VACUMETRICS INC., VENTURA, CA	
SCALE: N/A	APPROVED BY: KJD
DATE:	
FISHER SYSTEM - BLOCK DIA.	
DRAWING NUMBER: 1147-6	

APPLE II(E) COMPUTER  
PART # 50500







1	2	3	4	5	6	7	8	9	10	11	12	13	14	15
15V	15V	15V	15V	15V	15V	15V	15V	15V	15V	15V	15V	15V	15V	15V
15V	15V	15V	15V	15V	15V	15V	15V	15V	15V	15V	15V	15V	15V	15V
GND	GND	GND	GND	GND	GND	GND	GND	GND	GND	GND	GND	GND	GND	GND
-15V	-15V	-15V	-15V	-15V	-15V	-15V	-15V	-15V	-15V	-15V	-15V	-15V	-15V	-15V

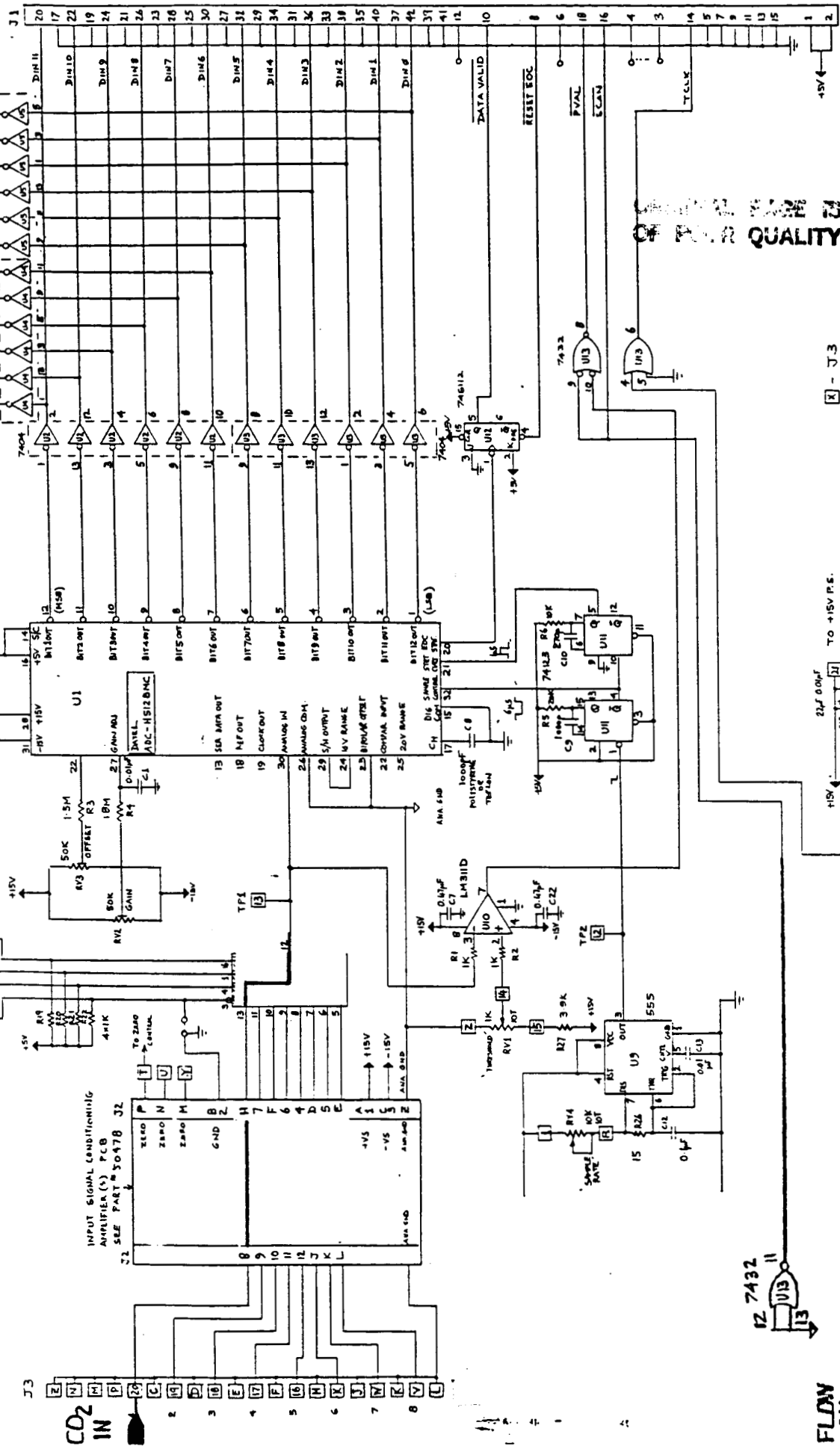

QUALITY  
OF YOUR QUALITY

X - J3  
O - flight to link wires

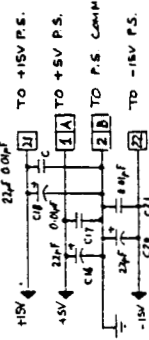

VACUMETRICS INC.  
PART 10-22-B2  
SCALE  
DESIGNED BY KJD  
REVISED BY  
VDSAS-I INTERFACE CAT# 50400  
SERIAL NUMBER  
1147-9

15V ± 1%

FLOW IN

# PARTS LIST

K L ENGINEERING CO.  
13000-6 San Fernando Road  
SYLMAR, CALIFORNIA 91342

TURBINE COMPENSATOR  
KTC-3

LIST TITLE PCB ASSEMBLY - KTC-3

COMPILED BY  
*pe*

DATE

CODE IDENT NO.

ITEM NO.	QTY	PART NO.	CODE IDENT	A S S Y	DESCRIPTION	REFERENCE DESIGNATORS	C H G
1		MC 14093	NOT		IC 14 PIN 4x SCHMITT TRIGGER	U1	
1		MC 14520	NOT		IC 16 PIN DUAL BI-COUNTER	U2	
1		8749	INTEL		IC 40 PIN 8-BIT MICROCOMPUTER	U3	
1		MC 14050	NOT		IC 16 PIN 6x BUFFER	U4	
1		MC 14538	NOT		IC 16 PIN DUAL MULTIVIBRATOR	U5	
2		MC 14527	NOT		IC 16 PIN BCD RATE MULTIPLIER	U6,7	
1		2N3904			NPN TRANSISTOR	Q1	
1					RESISTOR, METAL OXIDE 47Ω 1W 5%	R1	
1					RESISTOR CARB FILM 22K 1/4 (1/8)W 5%	R2	
1					15K -"-	R3	
1					3K3 -"-	R4	
2					100K -"-	R5,6	
1					470Ω -"-	R7	
2		EUN-36C	PANASONIC		TRIMMABLE POT. 1MΩ	R8,9	
1					RES. CARB. COFF. 15K 1/4W	R10,11,12,13	

ORIGINAL PAGE IS  
OF POOR QUALITY

PARTS LIST		K L ENGINEERING CO. 13000-6 San Fernando Road SYLMAR, CALIFORNIA 91342		TURBINE COMPENSATOR KTC-3			
LIST TITLE PCB ASSEMBLY - KTC-3				COMPILED BY	DATE	CODE IDENT NO.	
ITEM NO.	QTY	PART NO.	CODE IDENT	ASSY	DESCRIPTION	REFERENCE DESIGNATORS	CHG
3		EC3-1-1	TRANSFORMER		TANTALUM CAP. 3.3MF 25V	C1, 2, 6	
1			PIVOT		CERAMIC PLATE CAPACITOR 56 PF 100V	C3	
2		HVC-2	WIPER		MET. POLYCARBONATE CAPACITOR 0.33MF	C4, 5	
1					10MHZ CRYSTAL HC18U	Y	
2					DIN JACK, 7 PIN PCB	J1, 2	
1		KTC-2	K L ENGINEERING		PCB GLASS EPOXY 1/16x23x41	KTC-2	
					LED, RED		
1		DRD-10-RA	ALCO, AUGAT		DIP SWITCH, BCD	S1	

JK

ORIGINAL PAGE IS  
OF POOR QUALITY

TO J1 (VALVE DRIVER)  
↑

TO J1 (VDAS)  
↑

J1 Ground connections: odd pins 1 thru 49

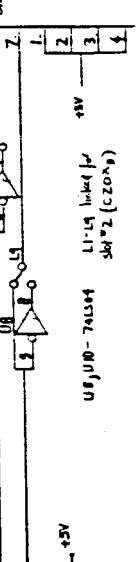
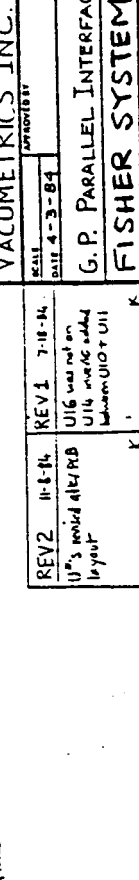
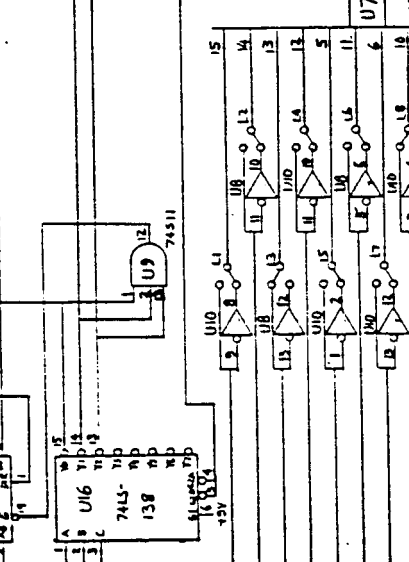
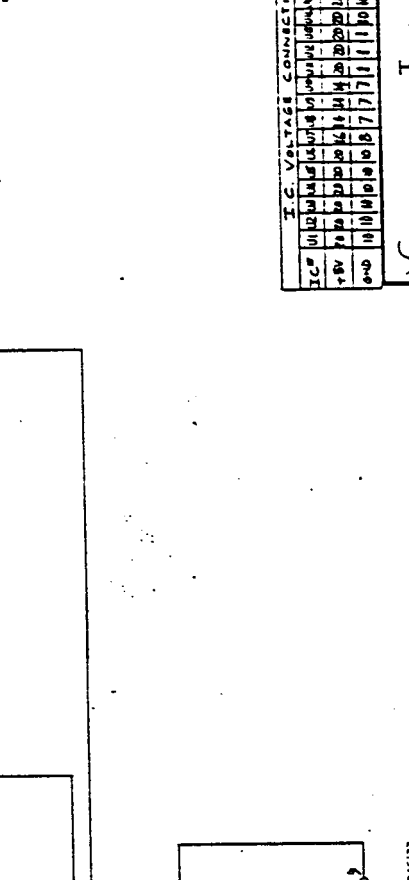
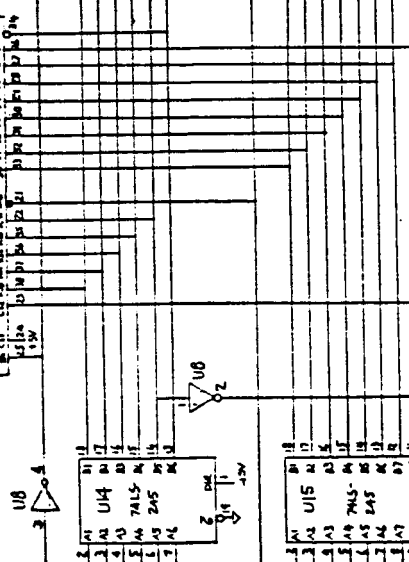
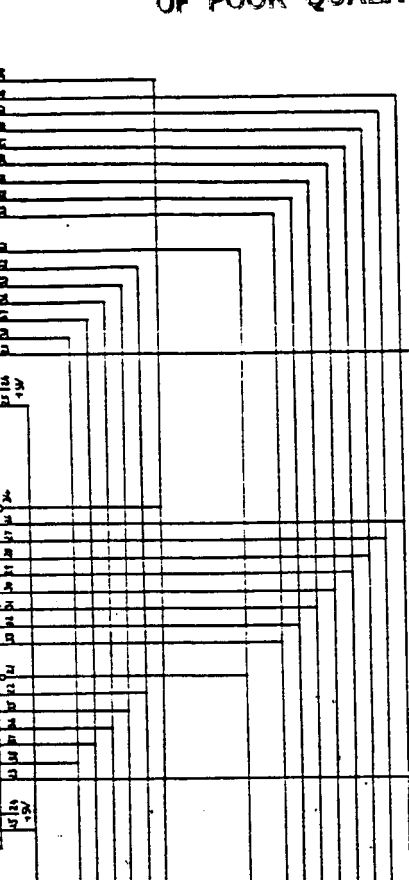
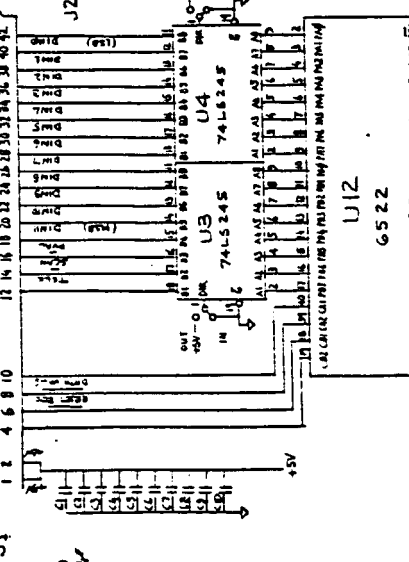
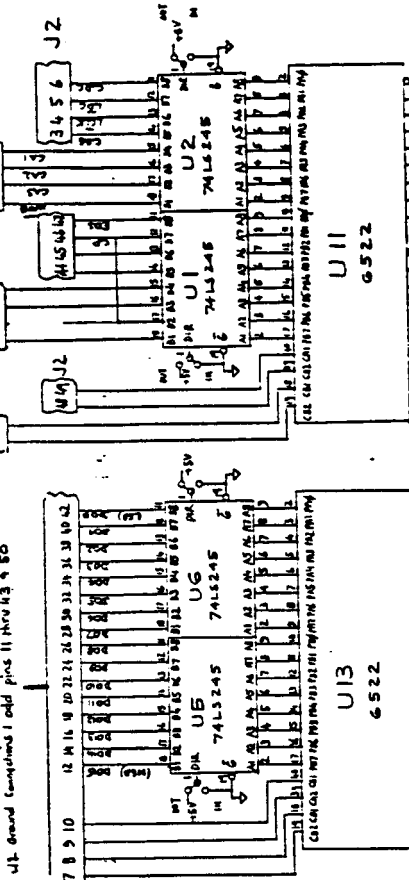

I.C. VOLTAGE CONNECTIONS															
IC#	U1	U2	U3	U4	U7	U8	U11	U12	U13	U15	U16	U17	U18	U19	U20
+5V															
0-5V															

VACUMETRICS INC. CA  
DATE 4-3-84  
G.P. PARALLEL INTERFACE - APPLE VIOS  
FISHER SYSTEM 1147-11

REV2 11-8-84  
U7's revised after RB layout

REV1 7-18-84  
U16 was not on U14 socket in early layout

APPLE 510 CONNECTOR

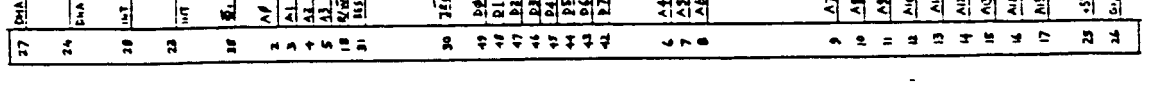

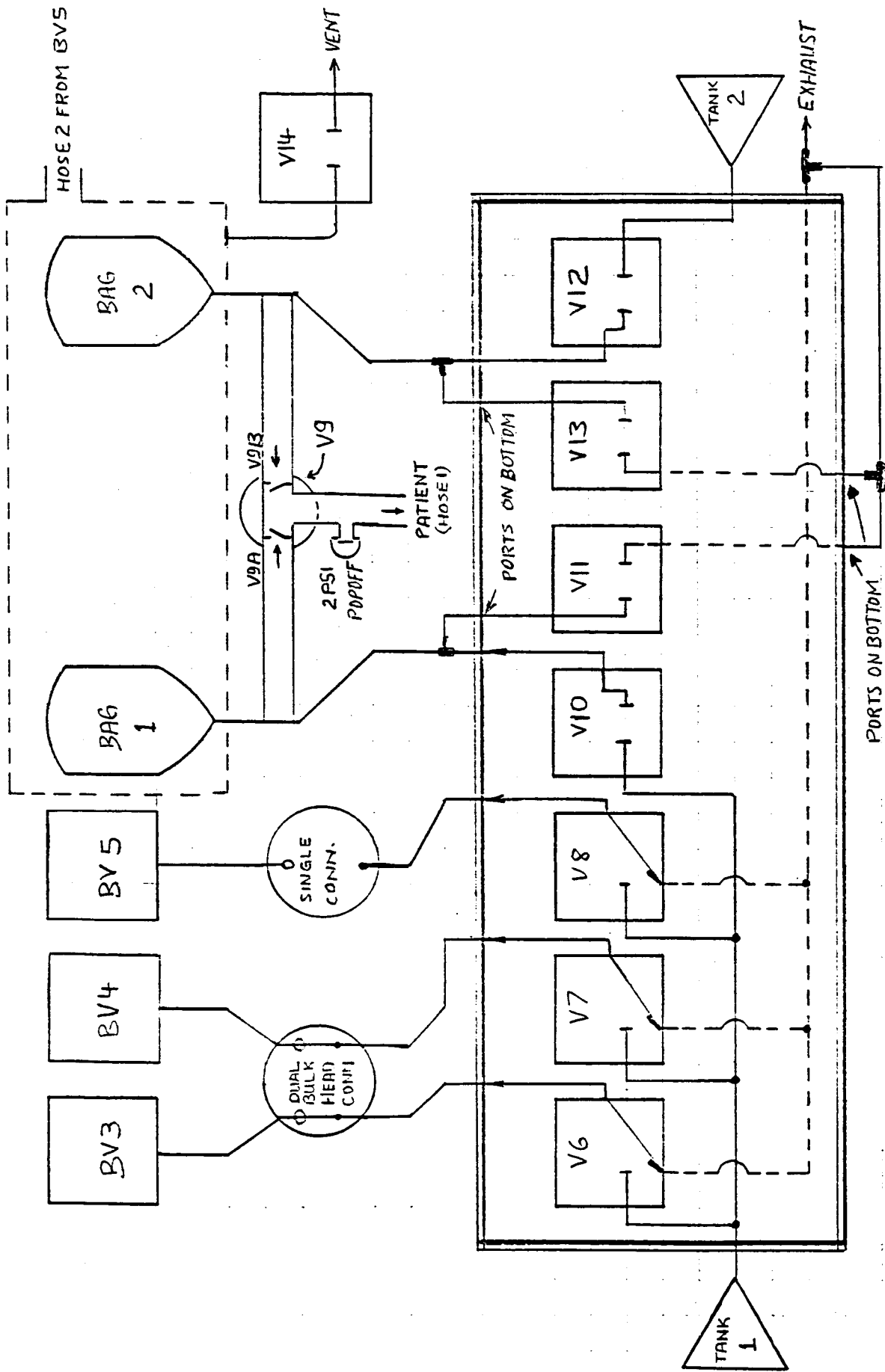

BY JH 6-27-85	VACUMETRICS INC GAS VALVE SYSTEM	NO 1147-3
------------------	-------------------------------------	--------------

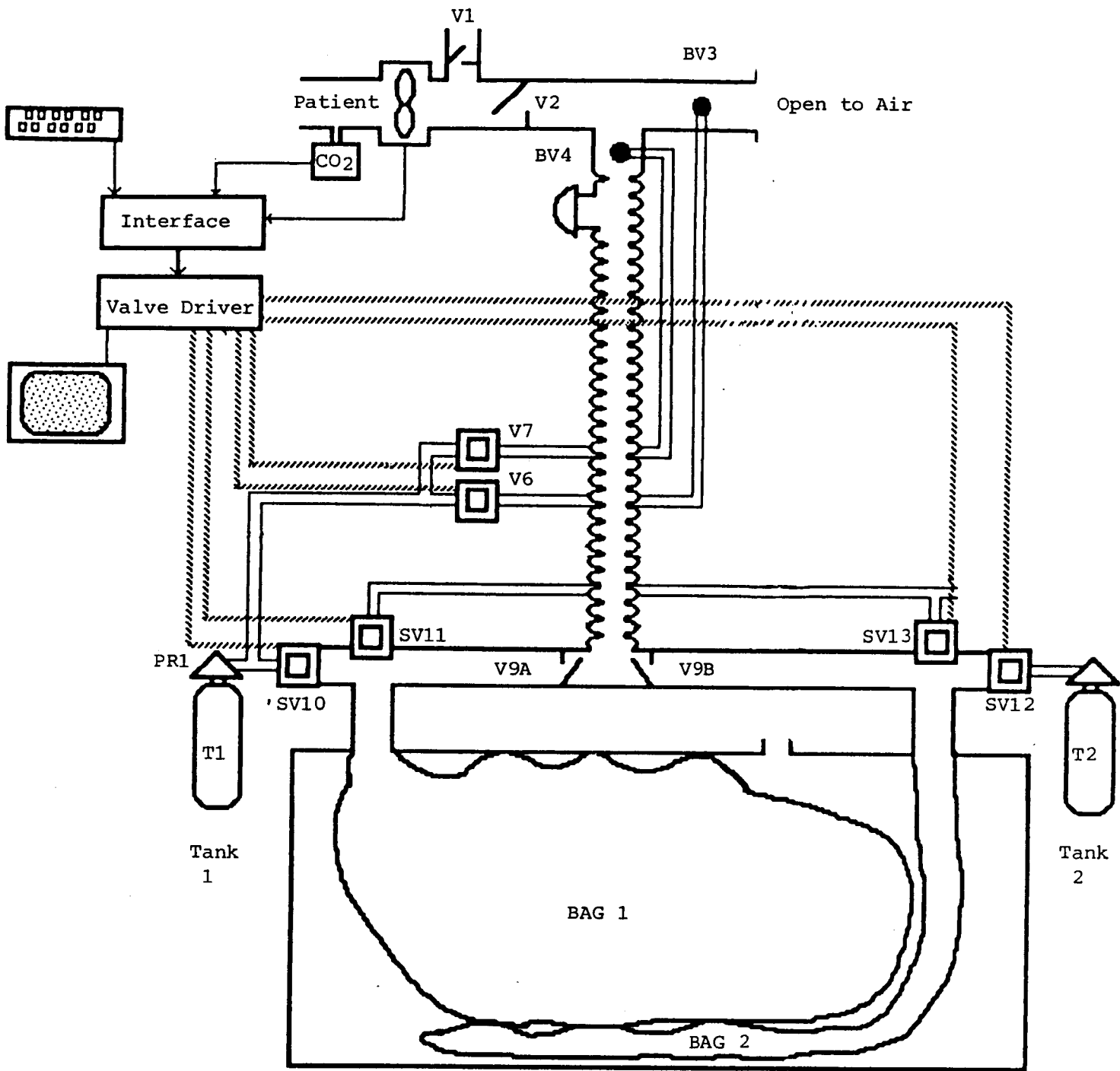

**FIGURE 1**

ORIGINAL PAGE IS  
OF POOR QUALITY

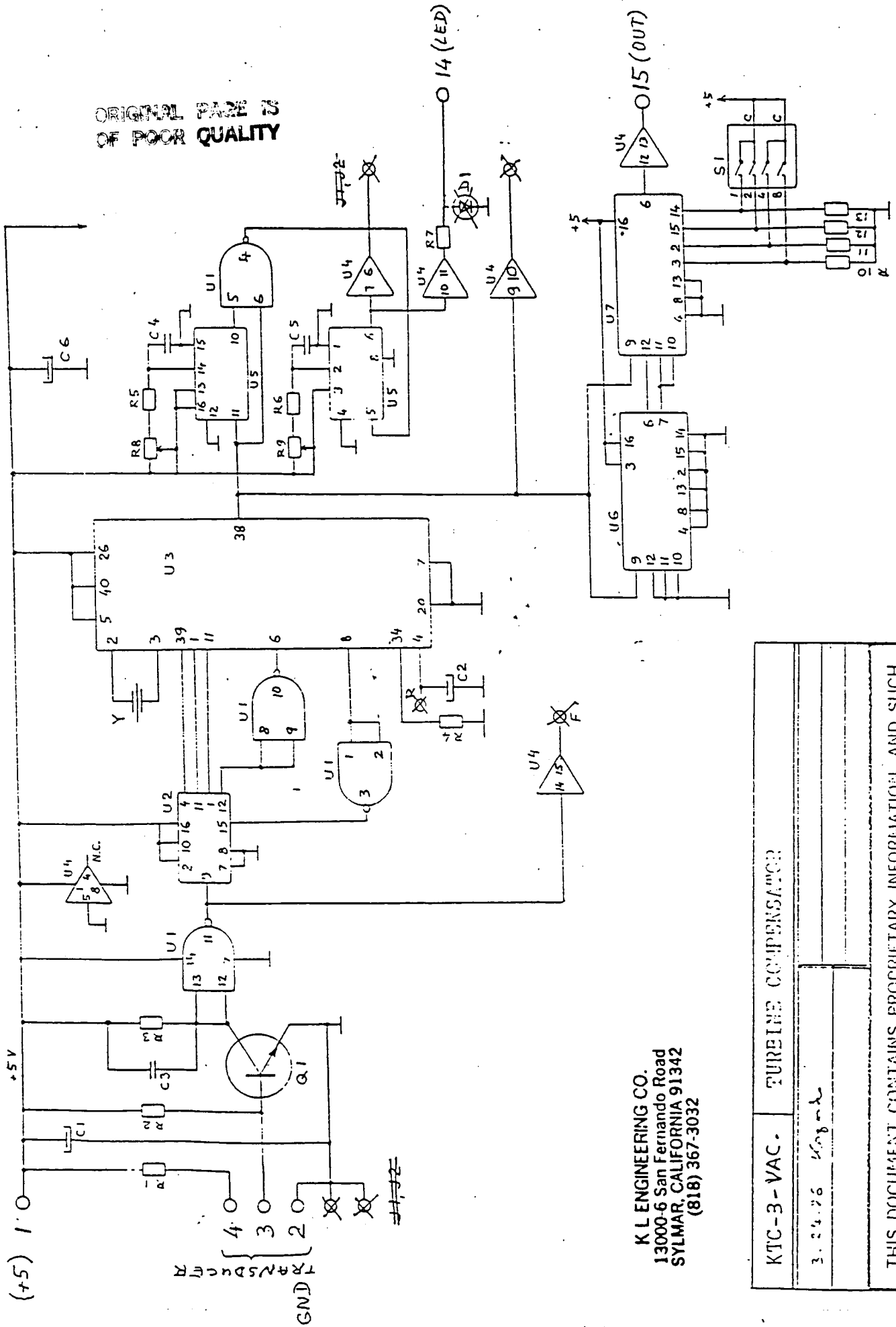

K L ENGINEERING CO.  
13000-6 San Fernando Road  
SYLMAR, CALIFORNIA 91342  
(818) 367-3032

KTC-3-VAC.	TURBINE COMPENSATOR
3.24.76	KL/mk
THIS DOCUMENT CONTAINS PROPRIETARY INFORMATION, AND SUCH INFORMATION MAY NOT BE DISCLOSED TO OTHERS FOR ANY PURPOSE NOR USED FOR MANUFACTURING PURPOSES WITHOUT WRITTEN PERMISSION FROM K L ENGINEERING COMPANY.	

Turbine MCT Chip Schematic  
FISHER SYSTEM 1147-10