

N87-16335

RF SWITCH POSITIONER FOR COMMUNICATIONS SATELLITE NETWORK

A.G. Storaasli, H.P. Griesser, R.W. Grant*

The RF switch positioner is a simple, lightweight, redundant positioning mechanism used to reconfigure the antenna beam on the INTELSAT VI satellite. It simultaneously rotates approximately 100 squareax waveguide switches through a full 360°.

BACKGROUND

INTELSAT VI is a geosynchronous communications satellite designed and built by Hughes Aircraft Company's Space and Communications Group for the INTELSAT consortium.** Five satellites are to be placed in orbit over three major regions: the Atlantic (AOR), Pacific (POR), and Indian (IOR) oceans. The system is designed to operate in any of the three ocean regions. If a satellite has to be moved, its communication payload must be reconfigured in orbit to operate in the new ocean region.

The 4 and 6 GHz zone coverage beams (see Figure 1) must be reconfigured to direct the maximum RF energy where needed (i.e., populated areas). The zones are reconfigured by changing the relative amplitudes and phases in the antenna feed network (Figure 2); the connection of each horn to the proper network is enabled by devices called squareax switches (Figure 3). The three switch conditions are affected by rotation of a crank shaft. Figure 3 shows the squareax switch in the Atlantic condition; the 120° rotation of the

*Hughes Aircraft Company, Space and Communications Group, El Segundo, California.

**The INTELSAT VI spacecraft is being developed and built by an international team of contractors lead by Hughes Aircraft Company for the International Telecommunications Satellite Organization (INTELSAT), the nonprofit cooperative of 110 countries that owns and operates the global communications satellite system used by countries around the world for international communications and by more than 27 countries for domestic communications.

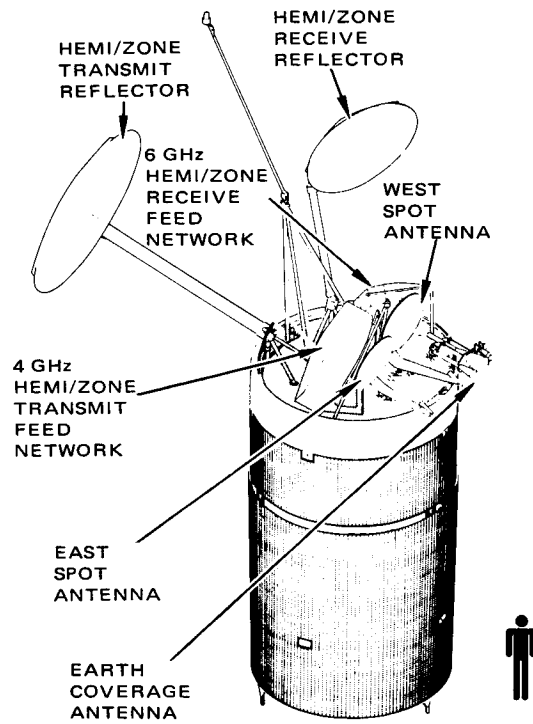

Figure 1. - Antenna farm configuration for INTELSAT VI.

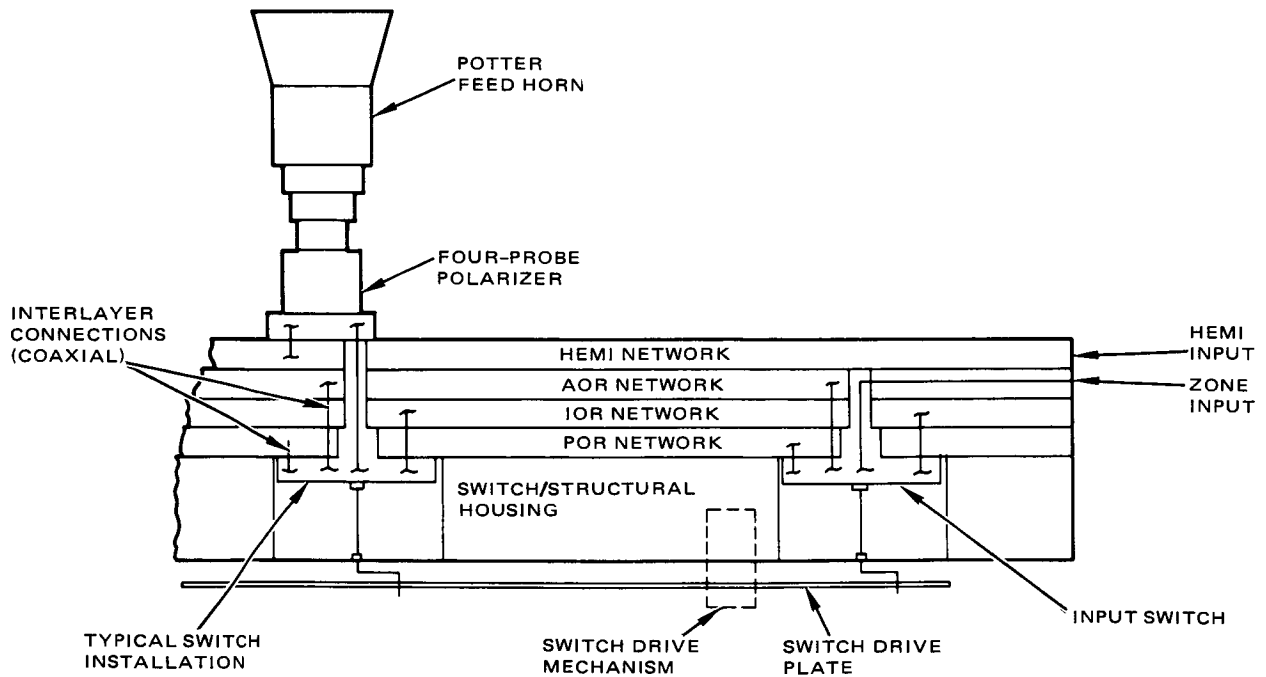

Figure 2. - Hemi/zone squareax network implementation.

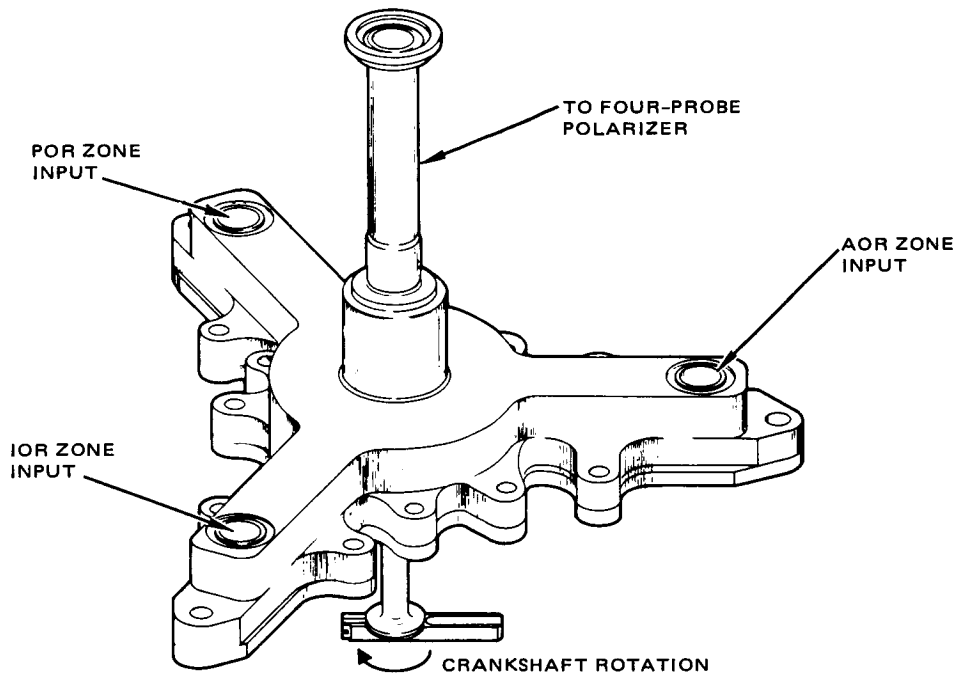

Figure 3. - Squareax switch.

crank provides connection for the POR or IOR zone, depending on the direction of travel.

Ninety-two such squareax switch/horn sets are on the transmit feed network and 91 on the receive feed network. Proper reconfiguration requires that all switch cranks on a network be rotated 120° (switches must be in the predetermined location at launch). The RF switch positioner performs the function of driving the 92 (or 91) cranks in unison.

APPROACH

An early concept considered was to use a long belt to turn pulleys (sprocketed or nonsprocketed) on each shaft (Figure 4). It appeared simple and lightweight, but serious design limitations became evident: maintaining belt tension, cumulative error buildup, and the need to deal with a mix of CW and CCW rotations.

The final solution was to use the swashplate arrangement shown in Figure 5. A lightweight plate is driven in an orbiting motion by cranks connected to the plate such that they are caused to rotate. By controlling the orbit of the plate, all switch cranks are simultaneously stopped at the proper 120° location.

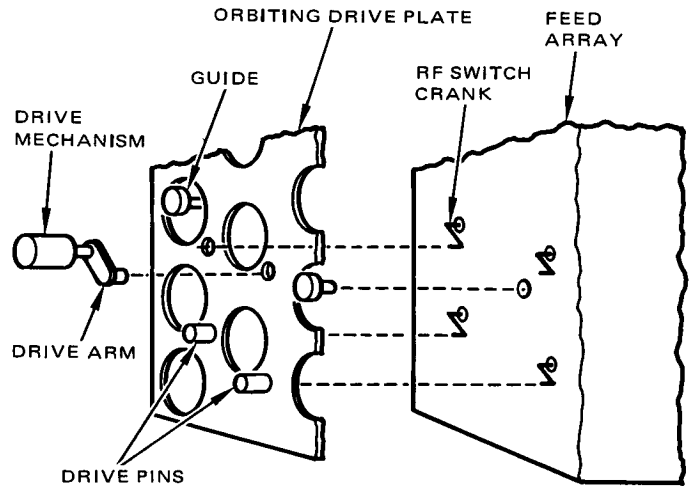
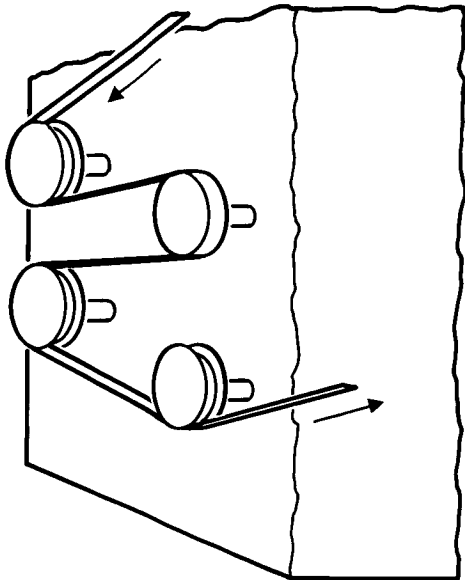

Figure 4. - Early belt drive concept. Figure 5. - RF switch positioner concept.

Detailed Description

Implementation of the design proved challenging considering the size of the feed networks, the number of switches, and the need to avoid mismatches between the plate and switches that may cause rotational errors or jamming.

Figure 6, a production honeycomb plate, was sized in thickness such that it could be held in place by a reasonable number of "mushrooms" in the launch vibration environment. The mushrooms, attached to the feed substrate, retain the plate laterally by their snug fit at respective plate lightening holes. The redundant motor set provides one rotational link; two passive links are located elsewhere to ensure proper orbiting motion. The cranks have slotted engagements so jamming cannot occur from tolerance buildups or thermal distortions.

Drive redundancy was a design baseline. Motor/gearhead pair plus differential gearing seemed a likely choice, however a more simple design was found. The Figure 7 design consists of two motor/gearheads connected by the mesh of respective output spur gears. Rotation of drive A pinion causes drive B (including plate) to orbit around drive A axis (drive B must be locked). Alternatively, if the redundant drive B is driven, its pinion will walk around drive A in the same orbital motion.

Redundant pots located on the base, connected by a similar crank, sense the orbital position. A tradeoff was performed on motor type dc versus stepper. The dc motor is workable, but the stepper motor was chosen since

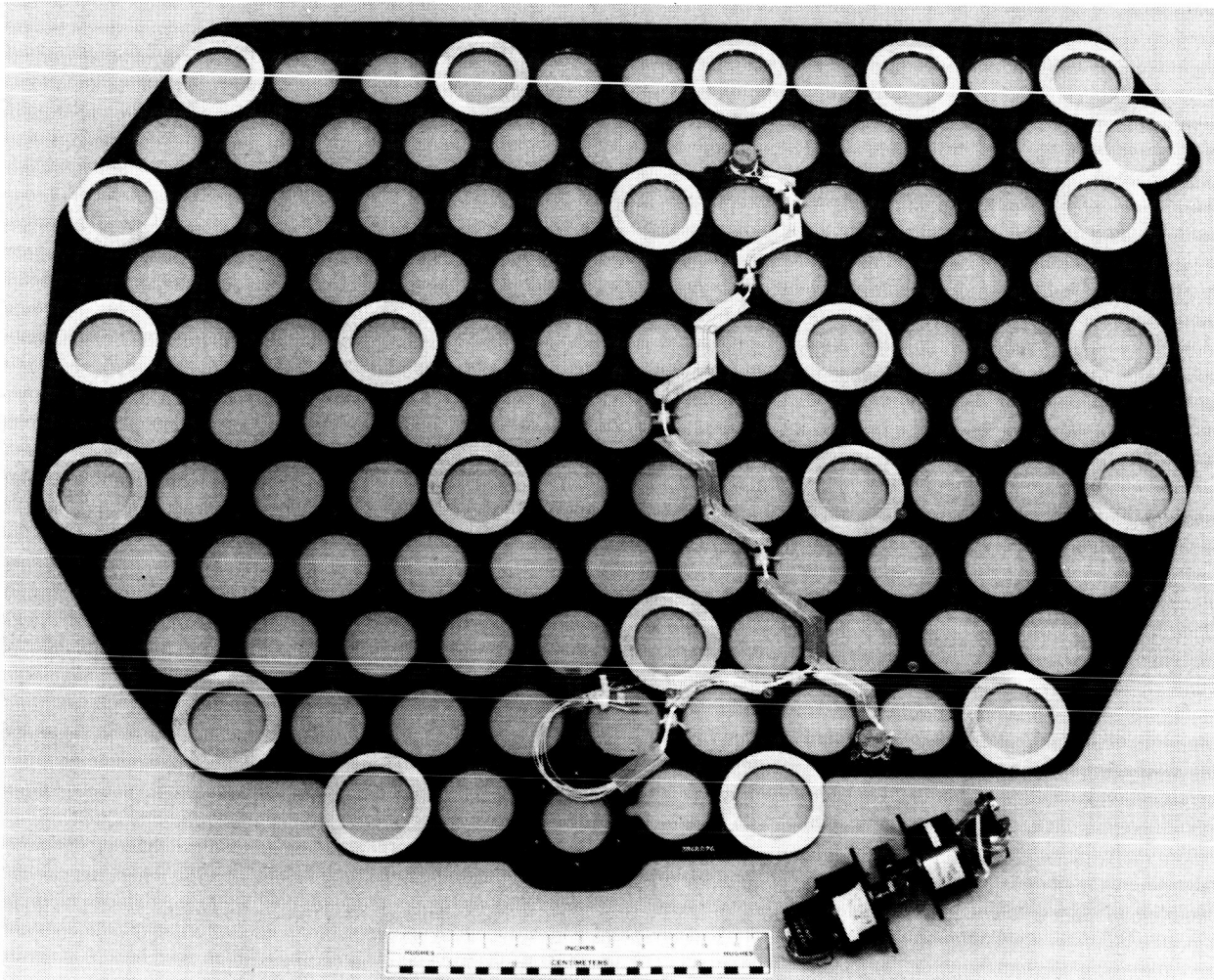

Figure 6. - Aluminum honeycomb plate and drive.

stepper motor drive electronics are being used in other areas of this spacecraft. Another advantage of stepper drive is that a predetermined step count can be used for accurate positioning. Each drive consists of a 45° size 11 stepper and 4126:1 gearhead. Figure 8 shows a production set of redundant motor geardrive and pots.

Table 1 lists the salient positioner characteristics. The 2° accuracy was not overly difficult to meet. The chief contributors were pot readout, manufacturing tolerance, and thermal gradients. The 4126:1 gear ratio was selected to give high torque margin, yet move the 120° at an acceptable rate.

Development and Testing

Engineering model testing performed early in the program proved helpful in locating some design problems or errors. It also gave some insight to

ORIGINAL PAGE IS
OF POOR QUALITY

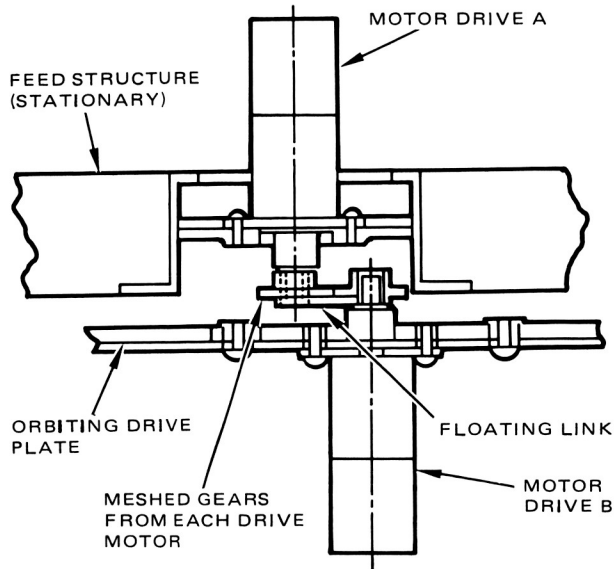

Figure 7. - Redundant drive configuration.

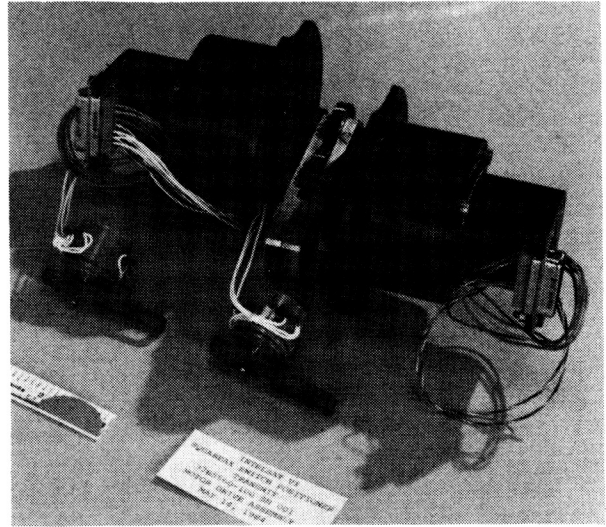

Figure 8. - Redundant motor gear drive and pots for one RF switch positioner assembly.

TABLE 1. RF SWITCH POSITIONER CHARACTERISTICS

POWER CONSUMPTION	15 W
ACCURACY	$\pm 2^\circ$
POSITION INDICATOR	REDUNDANT POTENTIOMETERS
RANGE	0° to 240°
SWITCHING TIME	20 MIN AT 25 STEPS/SECOND
GEAR RATIO	4126:1
POSITIONER TORQUE	>4.13 N.m (FACTOR OF 3 OVER WORST CASE OF TORQUE)
WEIGHT	
TRANSMIT UNIT	3.22 kg
RECEIVE UNIT	2.35 kg

ORIGINAL PAGE IS
OF POOR QUALITY

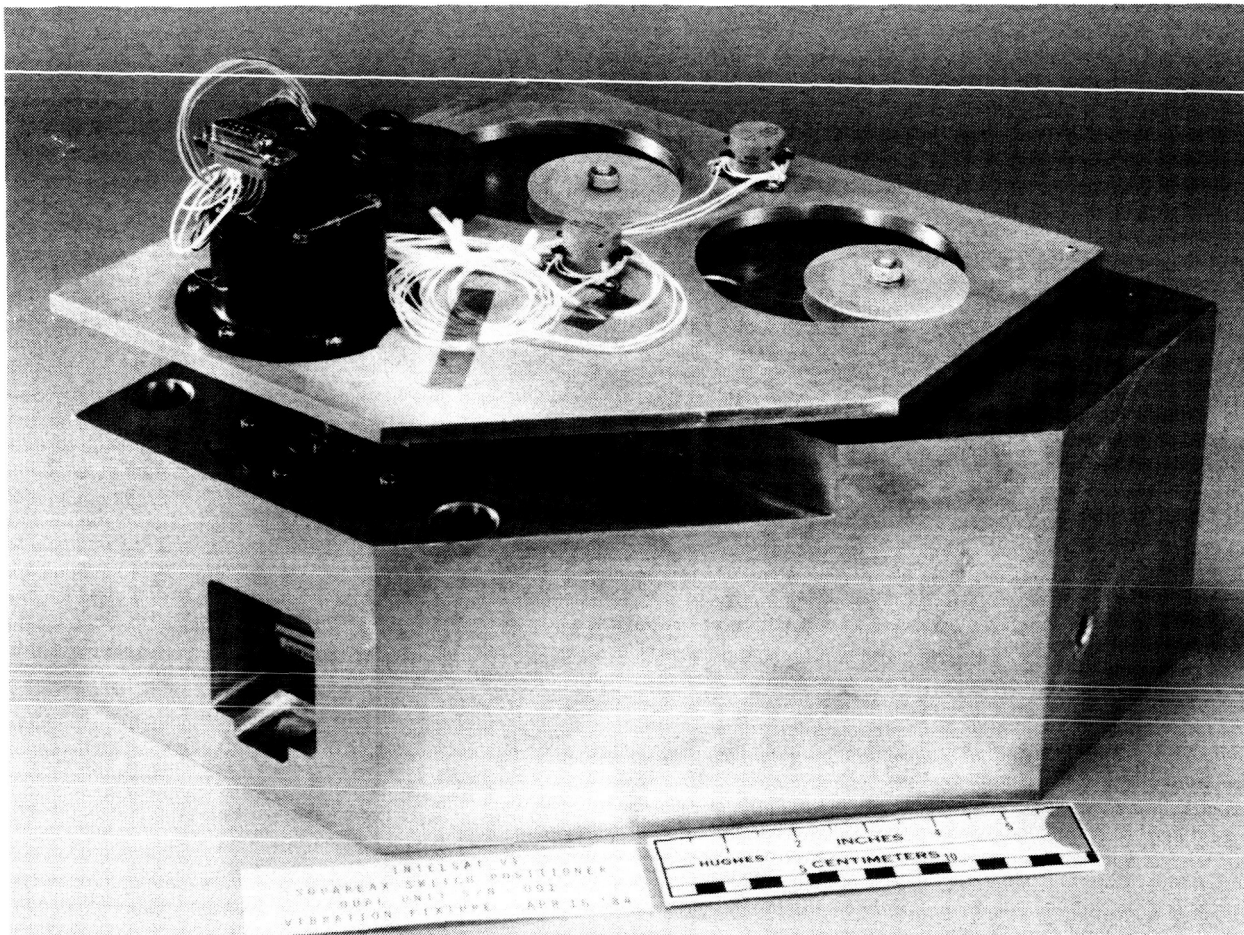

Figure 9. - Qualification unit with dummy plate section.

the lateral vibration nature of the plate which was a major concern because of the difficulty in analyzing such a plate.

Qualification testing consisted of random vibration and thermal-vacuum tests along with functional tests. To make the testing manageable, unit level testing consisted of the drive, idler cranks, pins, and plate section. Figure 9 shows the qualification level vibration setup. This is a reasonable screening test; additional testing takes place after installation to the actual feed assembly.

Only two anomalies were encountered in qualification testing. One idler link was damaged in vibration testing which was diagnosed as a setup problem resulting in unrealistic acceleration amplification.

The second anomaly took place during thermal-vacuum. To verify drive margin, clamp devices are installed to provide worst case frictional torque. Motor voltage is then reduced below the 28 Vdc nominal until the starting voltage is determined. During operation at the low temperature

ORIGINAL PAGE IS
OF POOR QUALITY

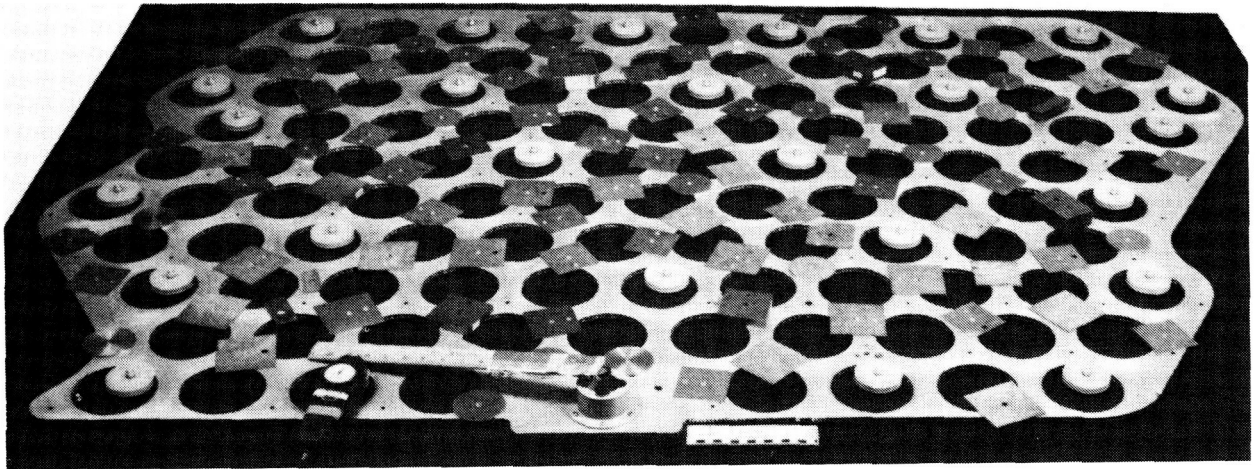

Figure 10. - Simulated thermal gradient test setup.

cycles the starting voltage was erratic although within specification. It was determined that the clamp experienced stiction, and was not a unit problem. The flight test setup now uses a magnetic particle brake to produce more consistent drag torque.

The aluminum honeycomb is susceptible to thermal gradients even though the area is covered with a thermal blanket. A special test was conducted to determine torque effects due to thermal gradient across the width of the plate.

The test setup (Figure 10) consisted of a full sized, aluminum honeycomb, transmit drive plate installed on the mushroom positioners. The positioners were mounted on a 1 inch thick plywood sheet and arranged in the flight configuration. A gear on a shaft replaced the front of the outer drive motor. The inner drive motor was mounted to the plywood substrate, and a link was provided to constrain the gears to orbit around each other.

The equivalent motor torque required to move the plate was measured with a torque watch. Larger torques were measured by attaching a moment arm to the shaft and driving it with a force guage as shown in Figure 10. The actual drive plate torque was twice the motor torque because of the 2:1 reduction of the gear linkage ratio.

The distortion due to a thermal gradient across the width of the plate was simulated by a uniformly distributed load on the plate face. The plate was mounted horizontally, and various weights were uniformly arranged upon it.

A 1°C gradient across the width of the plate has been predicted as the worst case. This gradient will cause a 0.30 cm deflection at the plate's center. The force this deflection will generate on the positioner disks can be simulated by distributing 3.6 kg uniformly across the plate. Margin can then be demonstrated by applying additional weights.

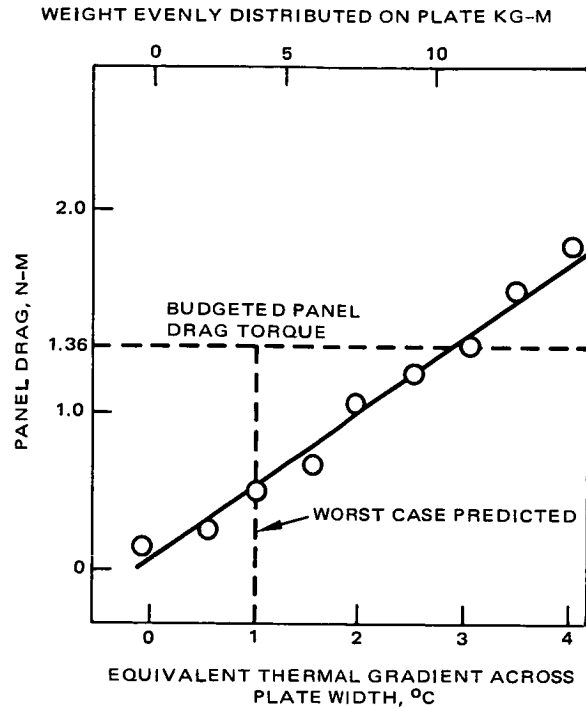

Figure 11. - Panel drag versus plate thermal gradient.

The results of the tests are shown in Figure 11. Data was taken in eight increments from 0 to 14.5 kg. The panel drag was linear with respect to the thermal gradient as expected. The panel drag exceeded the budget only at a 3°C gradient, three times the predicted worse case.

This test shows that the thermal gradient across the width of the plate will not impede the motion of the switch positioner. The low panel drag is primarily due to the low friction coefficient between the plate and the positioner disks and the low stiffness of the plate. A relatively small force is needed to hold the plate straight against thermal distortion.

CONCLUSIONS

The RF switch positioner has been space qualified and has performed to expectations in conjunction with the feed networks in range testing.