

N87-16752

D16-35

2.5P

49626

1986

NASA/ASEE SUMMER FACULTY FELLOWSHIP PROGRAM**MARSHALL SPACE FLIGHT CENTER
THE UNIVERSITY OF ALABAMA****QUANTITATIVE SCHLIEREN ANALYSIS APPLIED TO
HOLOGRAMS OF CRYSTALS GROWN ON SPACELAB 3**

Prepared by:	Howard L. Brooks
Academic Rank:	Assistant Professor
University and Department:	DePauw University Department of Physics and Astronomy DM604965
NASA/MSFC:	
Laboratory:	Test
Division:	Systems and Components
Branch:	Experiments and Components
MSFC Colleague:	Thomas L. Denton
Date:	August 8, 1986
Contract No.:	NGT 01-002-099 The University of Alabama

X

QUANTITATIVE SCHLIEREN ANALYSIS APPLIED TO
HOLOGRAMS OF CRYSTALS GROWN ON SPACELAB 3

by

Howard L. Brooks
Assistant Professor of Physics and Astronomy
DePauw University
Greencastle, Indiana

ABSTRACT

In order to extract additional information about crystals grown in the microgravity environment of Spacelab, a quantitative schlieren analysis technique has been developed for use in the Holography Ground System of the Fluid Experiment System located in Test Laboratory at Marshall Space Flight Center. Utilizing the Unidex position controller, it has been possible to measure deviation angles produced by refractive index gradients of 0.5 milliradians. Additionally, refractive index gradient maps for any recorded time during the crystal growth have been drawn and used to create solute concentration maps for the environment around the crystal.

The technique has been applied to flight holograms of Cell 204 of the Fluid Experiment System that were recorded during the Spacelab 3 mission on STS 51B (29 April - 6 May, 1985). A triglycine sulfate crystal was grown under isothermal conditions in the cell and the data gathered with the quantitative schlieren analysis technique is consistent with a diffusion limited growth process.

ACKNOWLEDGEMENTS

I am grateful for the opportunity that I have had to participate in the Summer Faculty Fellowship Program. The work that I completed this summer would not have been possible without the advice and assistance of Thomas L. Denton, David R. McIntosh, and Randy Posey.

I also appreciate the support of Bobby J. Johnson, Richard N. Stone and James H. Newton that allowed me to finish the project. Discussions with Rudy Ruff and Bill Witherow provided valuable insight in understanding some of the difficulties encountered during the research. I am grateful to Dr. R. B. Lal, the principal investigator for the TGS experiment for permitting me to analyze the flight holograms.

I would like to thank Dr. Mike Freeman for his encouragement and guidance throughout the program. The experience at Marshall Space Flight Center has been very enjoyable and I am indebted to the National Aeronautics and Space Administration and the American Society for Engineering Education for providing me with the chance to work in Huntsville.

INTRODUCTION

The Holography Ground System (HGS) at Marshall Space Flight Center is a vital part of the Fluid Experiment System (FES) designed to fly in Spacelab onboard the Shuttle. One of the many uses of HGS is reconstruction of space recorded holograms to investigate crystal growth. This paper describes a Quantitative Schlieren Analysis Technique (QSAT) that determines the refractive index gradients around crystals growing from solution.

Quantitative schlieren analysis is not done easily (Davies 1982, Eckert and Goldstein 1970, Vasil'ev 1971). However, the Unidex stepper motor controller on the HGS can locate the knife edge with an uncertainty of position of less than 10 micrometers. This precision enables the researcher to measure deflection angles of 0.1 milliradians. Since holograms are being analyzed it is possible to study the state of the test cell at a single moment in time with the knife edge in any position. Therefore it is possible to observe index of refraction gradients as small as 1×10^{-6} /mm. The optical elements in the HGS limit the deflection angle to a maximum of 1 degree, corresponding to a gradient of 2×10^{-4} /mm.

QSAT has been used to study the growth of a triglycine sulfate (TGS) crystal in Cell 204 in the FES onboard the Spacelab 3 (SL-3) mission that flew on Shuttle 51B from 29 April to 6 May, 1985. TGS crystals are good infrared detectors that operate at room temperature, but large crystals are difficult to grow under normal gravity at the Earth's surface. The index of refraction of TGS solution depends on the TGS concentration and has been studied by Kroes and Reiss (Kroes and Reiss, 1984). The end result of applying QSAT to the SL-3 holograms has been the production of refractive index gradient maps and average solute concentration maps for the growth period of the TGS crystal in Cell 204.

OBJECTIVES

The objectives of this work were to:

1. Analyze the reconstructed images of several holograms of the crystal growth test cell from the Fluid Experiment System on Spacelab 3 using schlieren techniques to develop a concentration gradient map around the crystal.
2. Develop a map of the solute concentration field of the test cell.
3. Refine the techniques involved in producing these maps to a "user guide" approach for follow-up research.

THEORY

Consider parallel light normally incident on a test cell as in Figure 1. If the test cell has a constant index of refraction then the light will remain parallel. When a lens is placed into this beam, all of the light will be brought to focus at the back focal point of the lens. Schlieren analysis uses a knife edge at this point to block the light and leave the image screen dark.

However, if the index of refraction in the test cell varies, then the light will be deviated from a parallel beam. If the light is bent upward by an angle α , see Figure 1, it passes above the edge and makes a bright spot on the screen. All rays bent upward reach the screen, regardless of where they pass through the cell. On the other hand, if the beam is deflected down by an angle β , the screen remains dark. To observe these deflections the knife edge is rotated 180 degrees, inserted from the top of the figure. Schlieren analysis is sensitive to deviations that are perpendicular to the knife edge. Deflections parallel to the edge remain blocked unless the knife edge is rotated 90 degrees.

If the knife edge is moved a distance, a , above the location where the undeviated light was blocked, then some of the screen is still illuminated while more of the screen is dark. The boundary between the bright and dark regions locates where the light has been bent by the angle α (Vasil'ev, 1971). For small deviations (Eckert and Goldstein, 1970), the angle α , in radians, equals the ratio of a to the focal length of the lens f .

$$\alpha = a/f \quad (1)$$

This angle is greater than the deflection angle produced by a refractive index gradient because of refraction at the fluid-cell wall-air boundary. Applying Snell's law to the two plane interfaces, see Figure 2, yields for small angles,

$$n'' \alpha'' = n \alpha \quad (2)$$

where n is the refractive index of air, α is the observed angle, n'' is the refractive index of the fluid and α'' is the deflection angle in the fluid. Substituting from (1) and solving for α''

$$\alpha'' = (1/n'')(a/f) \quad (3)$$

since the refractive index of air is 1.00.

To understand the relationship of the deflection angle to the refractive index gradient (Wolter, 1926 or Meyer-Arendt, 1972), consider the model of the test cell presented in Figure 3. Assume that the refractive index only varies in the y -direction. As parallel wavefronts enter the cell, they obey Fermat's principle and travel faster where the refractive index is smallest and complete the same optical pathlength in any time period. Or in equation form,

$$n ds = n'' ds'' \quad (4)$$

where n and n'' are the indices of refraction along the paths ds and ds'' and $n'' = n + dn$.

The angle between the two wavefronts is the deviation angle α'' . Looking at Figure 3,

$$ds = R d\alpha \quad (5)$$

$$ds'' = (R - dy) d\alpha \quad (6)$$

From (4)

$$ds - ds'' = (1 - (n/n''))ds \quad (7)$$

and from (5) and (6)

$$ds - ds'' = (dy) d\alpha \quad (8)$$

Setting these relationships equal and solving for $d\alpha$

$$d\alpha = (1/dy)(1 - (n/n''))ds \quad (9)$$

Recalling $n'' = n + dn$

$$d\alpha = (1/n'')(dn/dy)ds \quad (10)$$

Integration finds the total deviation angle α'' produced by travelling through the cell a distance z . If n'' and dn/dy do not vary with z ,

$$\alpha'' = (1/n'')(dn/dy)z \quad (11)$$

Equating the expressions for α'' in (3) and (11) and solving for the gradient dn/dy ,

$$dn/dy = (a/f)(1/z) \quad (12)$$

From symmetry, the total two dimensional gradient is

$$\nabla n = \sqrt{(dn/dx)^2 + (dn/dy)^2} \quad (13)$$

If there is a dependence of the gradient on the distance through the cell, which is often true, then (13) is the value of the gradient averaged over z .

As the TGS crystal grows, it removes solute from the solution and reduces the concentration of TGS surrounding the crystal (Owen and Kroes, 1985). The relationship of the refractive index to the concentration is understood (Kroes and Reiss, 1984), and is plotted for 42 degrees Celsius in Figure 4. With this information, the gradients can be used to determine concentrations.

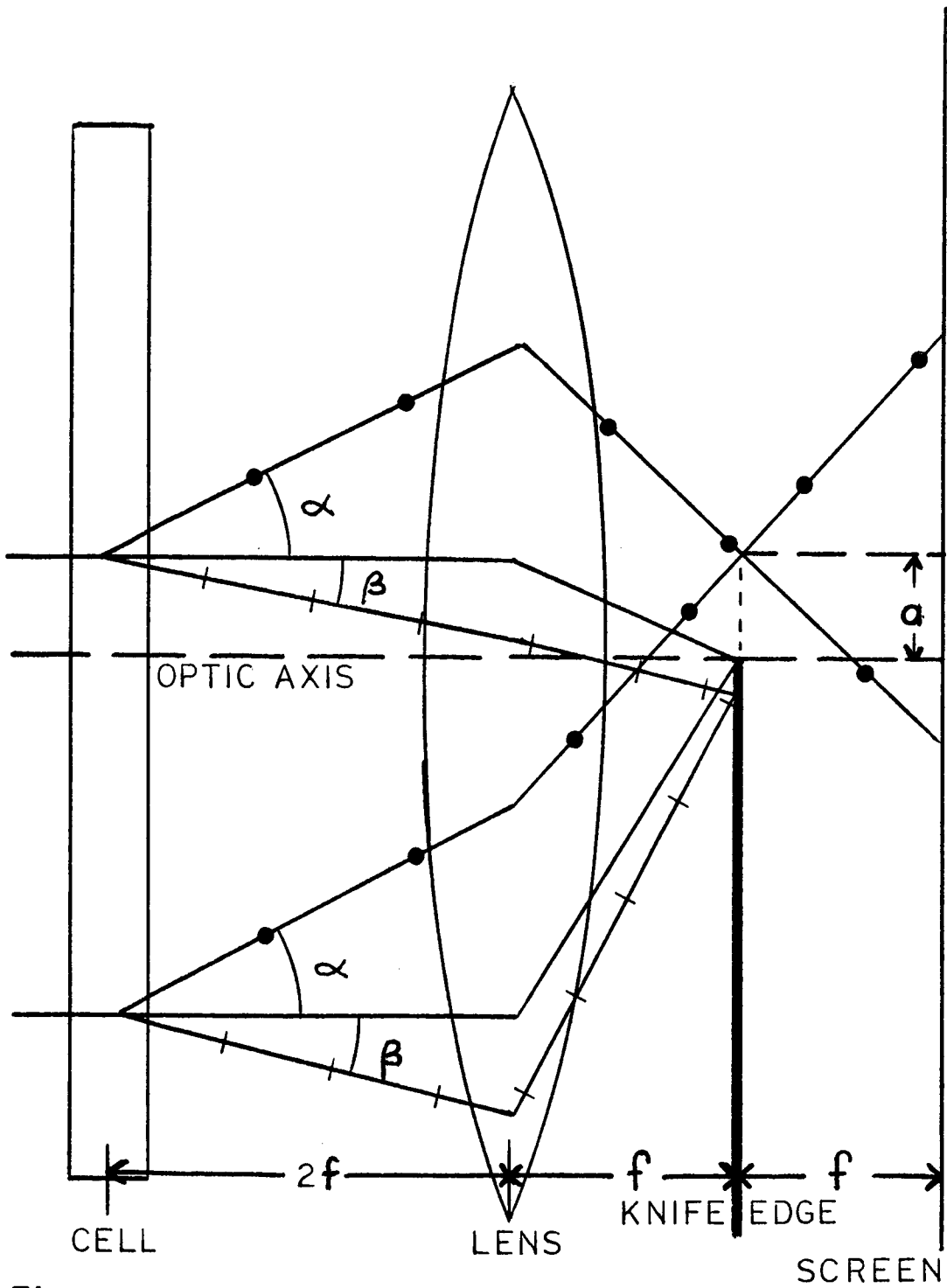

Figure 1- Optical System for Schlieren Analysis

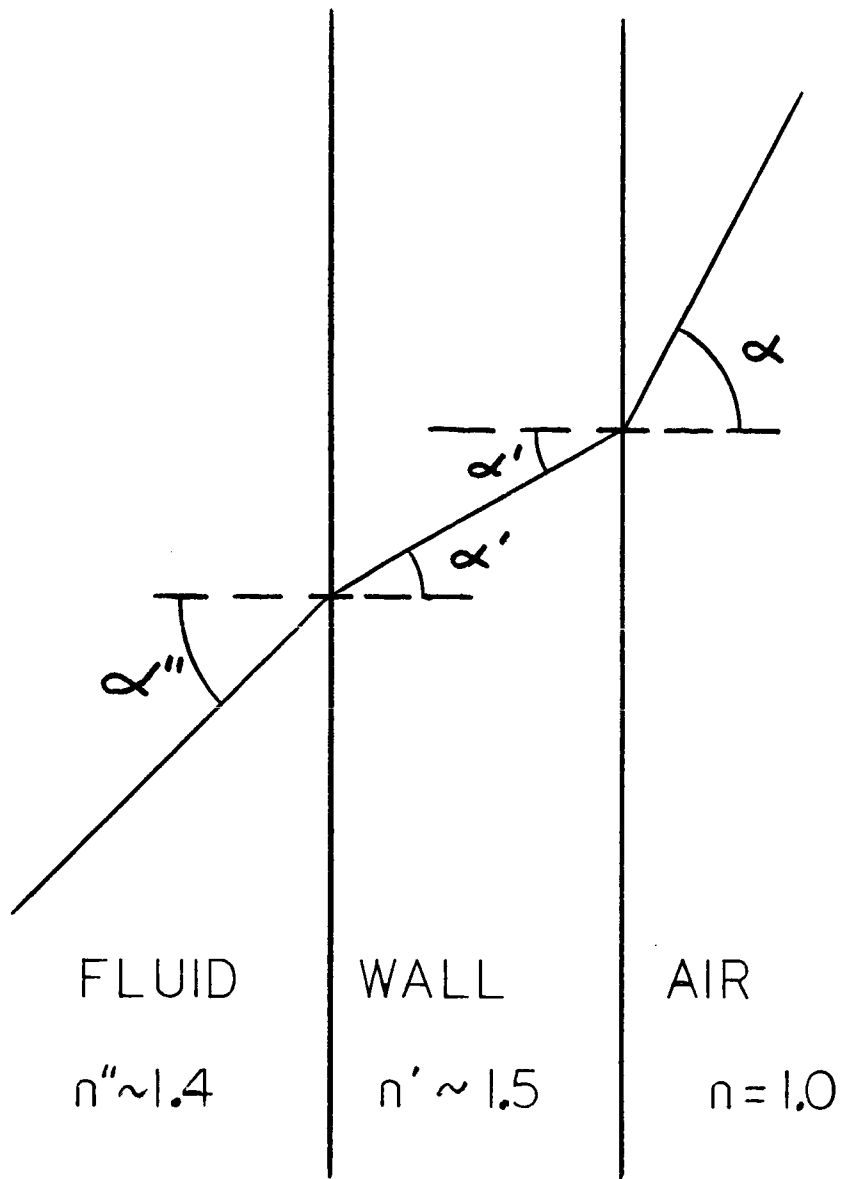

Figure 2- Ray Path Leaving Cell Fluid

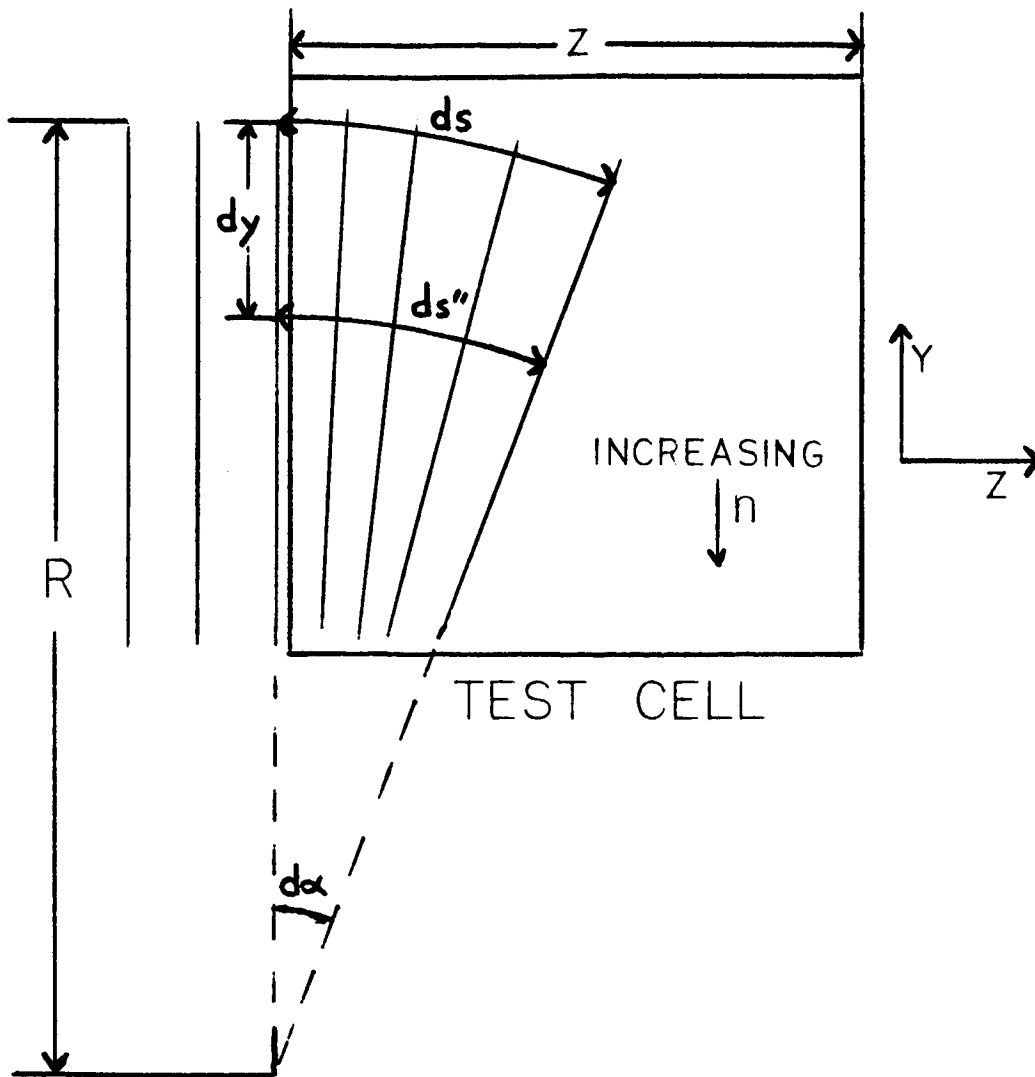

Figure 3- Wavefronts Passing Through Test Cell

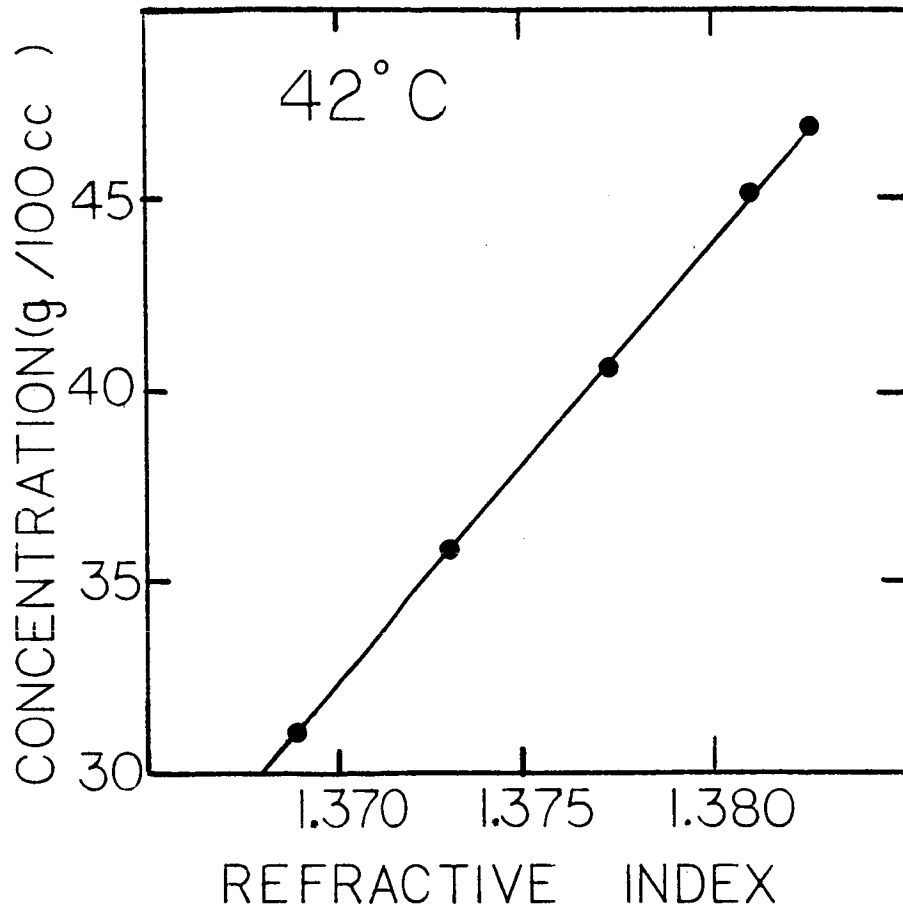

Figure 4- TGS Concentration versus Refractive Index at 42 degrees Celsius

APPARATUS AND PROCEDURE

Reconstruction of the FES flight holograms was completed on the Holography Ground System (HGS). The HGS consists of a Newport Research Corporation Model RS-516-18 5' x 16' x 1.5' enclosed flat table suspended on Model XL-8 pneumatic legs. A Spectra Physics Model 125 helium neon laser rated at 50 milliwatts is used with the optical elements on the table to produce a uniform beam to illuminate the holograms. Precise positioning of the knife edge is accomplished with the Unidex IIIa controller manufactured by Aerotech. Exposure times are set on a Newport Research Model 845 electronic shutter.

To begin QSAT the HGS must be configured for schlieren analysis as detailed in the Operations Manual (TAI Corporation, 1984). The first hologram to be reconstructed should be of the test cell when the solution was of uniform concentration. This condition will produce an undeviated parallel beam of light. The knife edge must be inserted into the beam at the back focal point of the lens, 100 cm behind the lens. This location can be confirmed by watching the field darken uniformly as the knife edge is moved through the focal plane (Eckert and Goldstein, 1970). The position is determined where no light reaches the image screen located 100 cm behind the knife edge.

With the initialization procedure completed, a growth process hologram can be studied. If there are any gradients in the solution that deflect the light over the knife edge, then bright regions appear on the screen at points in the image plane corresponding to increasing gradient locations in the cell. A photographic record of the image of the cell is obtained using Polaroid Type 55 film, which produces a positive and a negative. The knife edge is moved

farther across the optic axis, typically 0.50, 1.00, 2.00, and 5.00 mm and photographs taken for each of these positions.

When the set of photographs for a given knife edge orientation on a single hologram have been taken, the knife edge is returned to the zero position with the Unidex controller. The knife edge can be rotated to a new orientation and the undeviated hologram initialization procedure repeated. A complete set of data requires photographs with the knife edge oriented at 0 degrees, 90 degrees, 180 degrees, and 270 degrees. These orientations identify all refractive index gradients in the cell at the time the hologram was exposed. Figure 5 shows the effect of rotating the knife edge 180 degrees for hologram 3P083. Figure 6 shows the change as the knife edge is moved 2.00 mm and 5.00 mm above the optic axis.

Next, a map is produced indicating lines of equal deviation angle within the cell. The negatives are enlarged five times, using an overhead projector, and the boundary between bright and dark regions of is marked and coded to indicate knife edge orientation and deviation angle (as in Figure 7). Tracing paper is laid over this map and all intersection points marked. Gradients are the vector sums of the two orthogonal components at these points which can be plotted on maps (see Figure 8). Average solute concentration maps (see Figure 9) are easily drawn since isoconcentration lines will always be perpendicular to the gradient vectors. It is assumed that the zero gradient points are at locations of saturated solution and that the gradient varies smoothly through the regions between points where precise values are known. The change in the index of refraction is found by integrating the gradient over the distance from the zero gradient points. These refractive index values can be used with Figure 4 to determine the average solute concentration.

ORIGINAL PAGE IS
OF POOR QUALITY

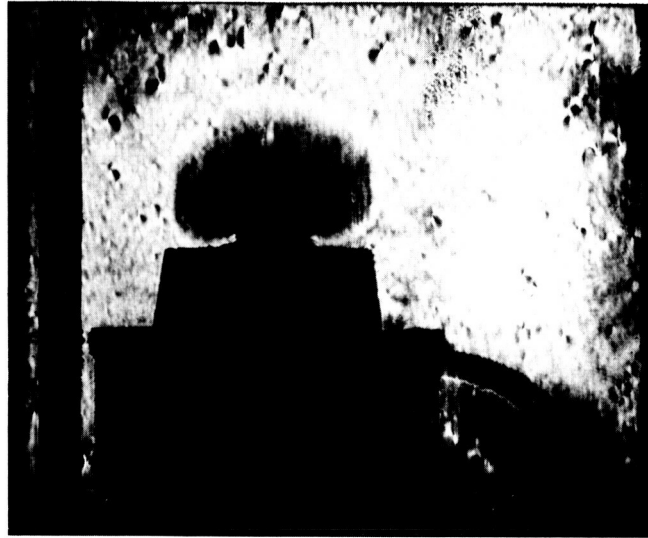

Figure 5- Schlieren photos from 3P083
TOP- Knife Edge at 0 degrees
BOTTOM- Knife Edge at 180 degrees

ORIGINAL PAGE IS
OF POOR QUALITY

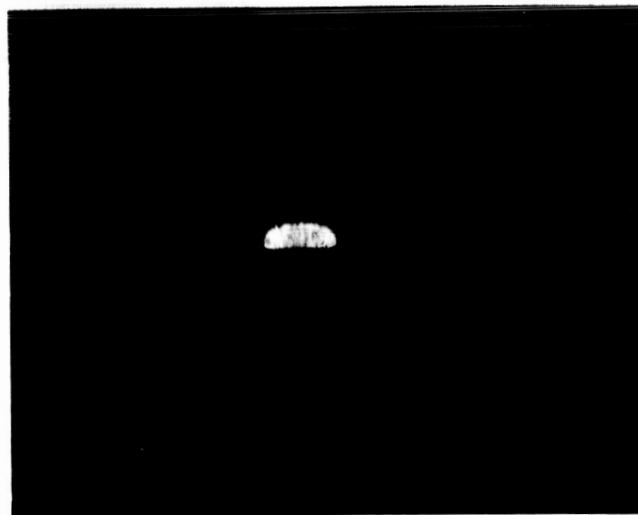

Figure 6- Schlieren Photos from 3P083 with
Knife Edge at 180 degrees
TOP- $\alpha'' = 2$ milliradians
BOTTOM- $\alpha'' = 5$ milliradians

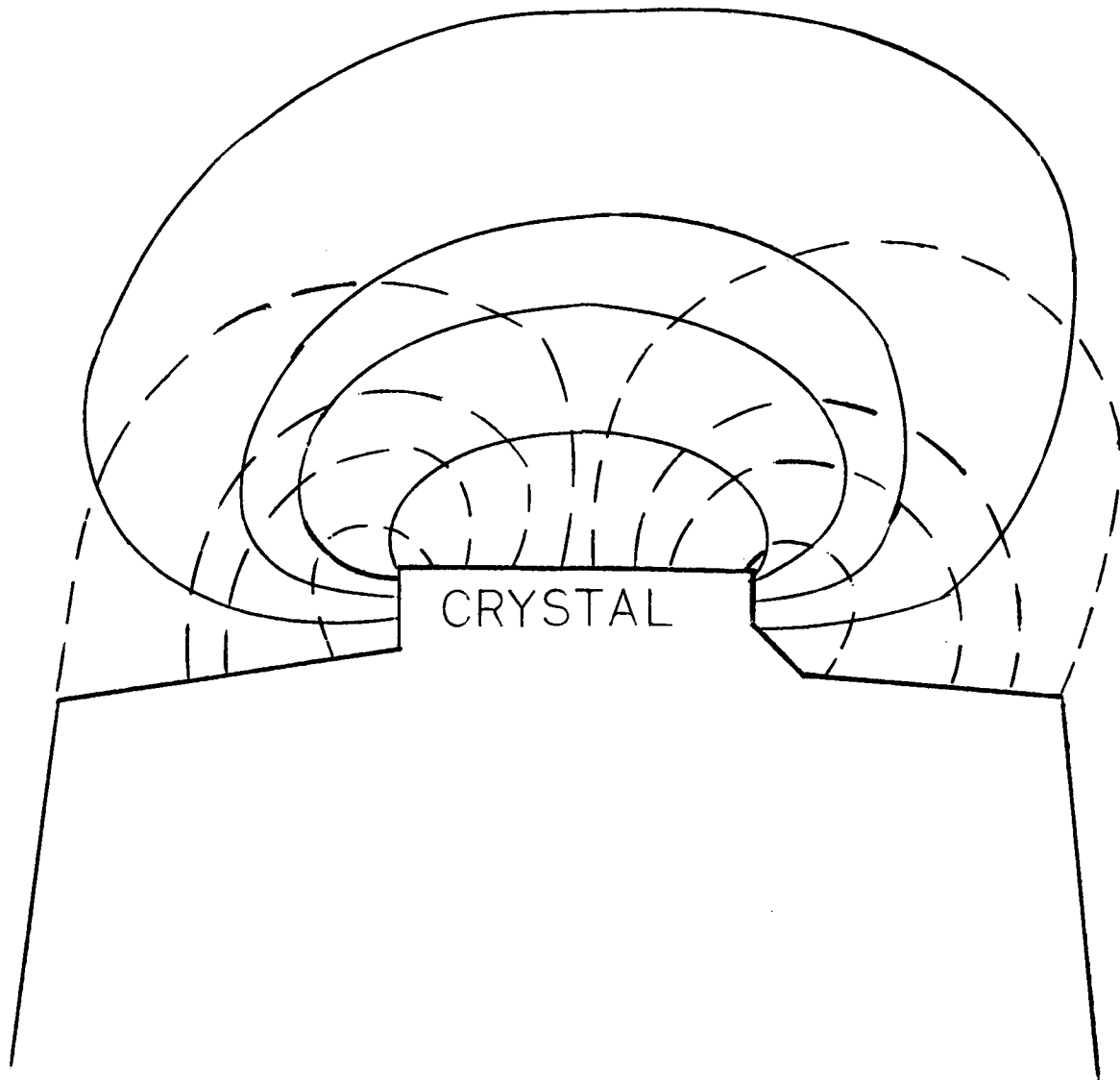

Figure 7- Boundary Lines for 3P083

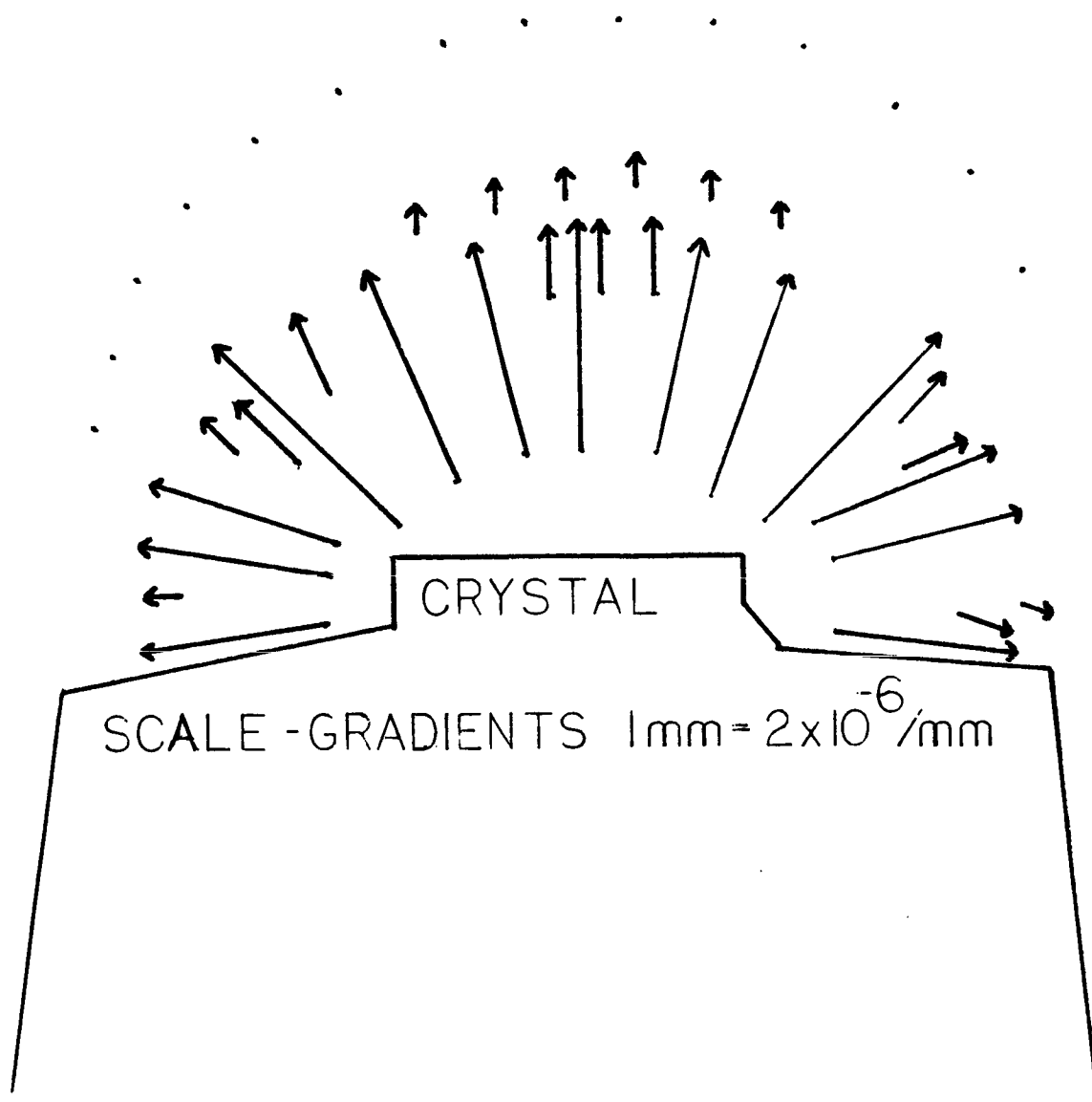

Figure 8- Gradients for 3P083

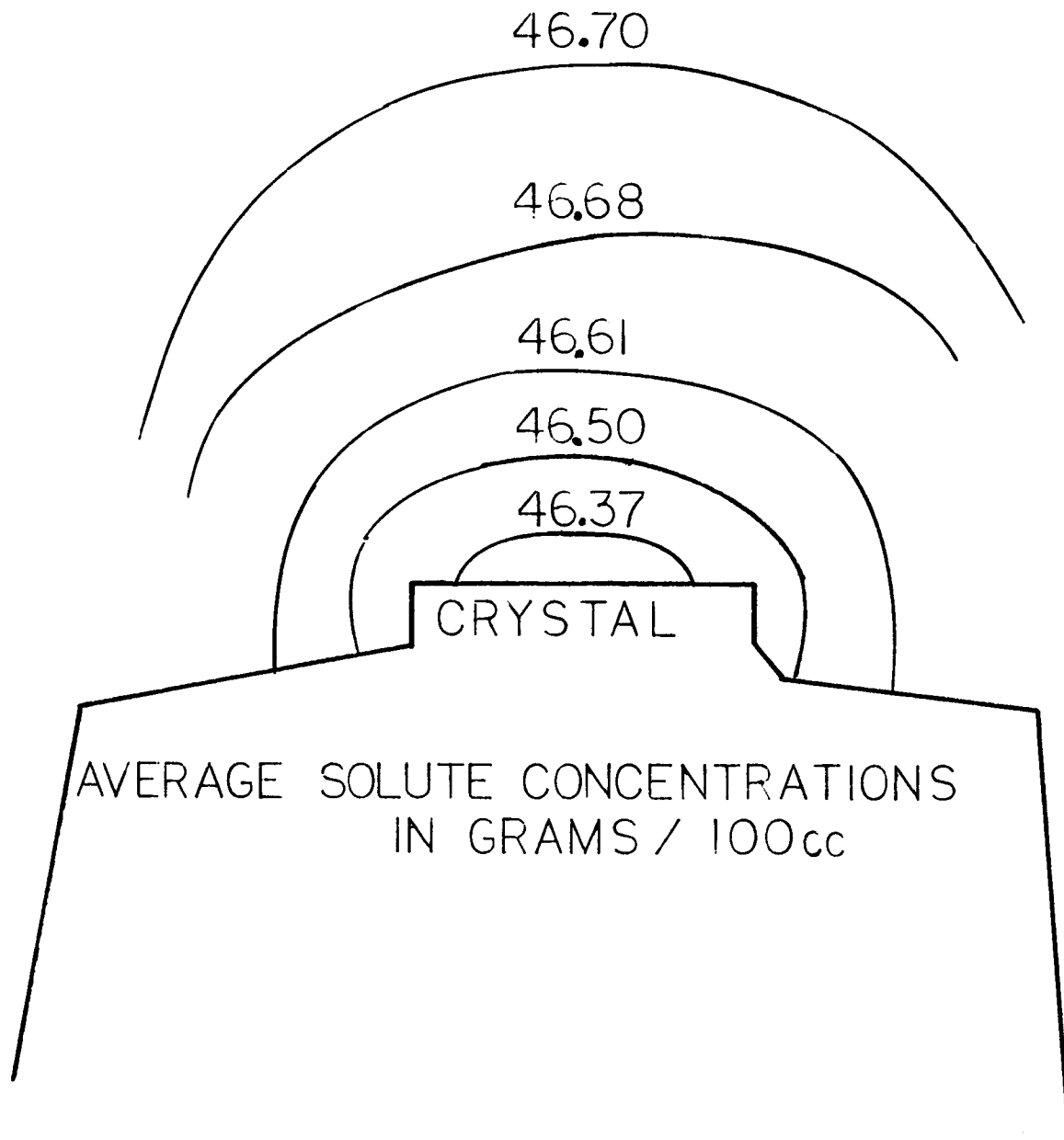

Figure 9- Isoconcentration Lines for 3P083

DATA ANALYSIS

The results of applying QSAT to the Cell 204 holograms are consistent with the theoretical expectations. Table 1 lists the holograms studied, the Mission Elapsed Time, and the time since cap opening. All Schlieren photographs, boundary line plots, gradient and average solute concentration maps are stored in the HGS at MSFC. Discussion of the crystal growth can be divided into three time periods, distinguished by the behavior of the refractive index gradient.

Cell 204 was operated in an isothermal environment for the growth period at 42 degrees Celsius. However, at the time the cap was opened, the sting and solution were at a higher temperature to allow the surface of the seed crystal to dissolve. The dissolving crystal adds more TGS to the solution near the crystal. Schlieren photographs from 3P043 show the crystal is still dissolving. In 3P047 the data exhibit very small gradients which suggest that the crystal is growing, although the growth could not have begun much before the exposure, 2h:43m:57s after the cap was opened. The next hologram suitable for Schlieren analysis, 3P049, shows a growing crystal.

Holograms for almost the next nine hours show a steady, uniform, symmetric growth pattern in the gradient. The location of the zero gradient points above the crystal face move from 2.0 mm in 3P049 to 14.8 mm in 3P083. The magnitude of the gradient inside these points also increased with gradients of 5×10^{-5} /mm first appearing in 3P055 0.5 mm above the crystal face. By 3P083 these gradients were found 3.3 mm above the face, and a gradient of 9×10^{-5} /mm 0.5 mm above the crystal.

This regular growth pattern changed in 3P102. The same size gradients were found slightly farther

above the right side of the crystal than the left. By 3P108 there were large asymmetries in the zero gradient, but gradients remained symmetric near the crystal. From 3P102 through 3P133 the gradients continued to extend farther away from the crystal face, while there were only slight changes near the edges of the crystal. In 3P133, the zero gradient points were 17.8 mm above the face and 5×10^{-5} /mm gradients were 3.5 mm above the crystal. The later holograms, 3P151 and 3P161, may indicate a slight decrease in the gradients around the crystal.

Average solute concentration was determined by curve fitting. Starting from the zero gradient and moving in the normal direction toward the crystal, the gradient could be found by,

$$\nabla n(y) = k y^2 \times 10^{-5} / \text{mm} \quad (14)$$

where y is the distance in mm from the zero gradient and k is a fitting constant. The average k values with standard deviations for each hologram are given in Table 2. Early in the growth the k values change rapidly before reaching a fairly steady value. For 3P102 to 3P161 the average value of k is $0.0275 \pm .0040$. Integrating this function over the displacement from the zero gradient line enables values for the refractive index, and subsequently the average solute concentration, to be assigned to each isoconcentration line. Table 2 also shows the largest measurable deviation angle, about 0.5 mm above the crystal, for all holograms with angles greater than 5 mrad. All of the data suggest that the crystal started growing slowly, then grew more rapidly before slowing again during the last 12 hours.

There are also indications in all of the holograms of some very small gradients in other portions of the cell. These gradients may be the result of thermal variation within the cell or relate to other locations where TGS was deposited during the growth period.

TABLE 1 - CELL 204 Holograms Studied with QSAT

Hologram Number	Mission Elapsed Time	Time from Cap Opening
3P032	110:04:44	- 0:40:49
CAP OPENING	110:45:33	0:00:00
3P043	112:02:05	+ 1:16:32
3P047	113:29:30	+ 2:43:57
3P049	115:00:28	+ 4:14:55
3P053	116:02:38	+ 5:17:05
3P055	116:47:30	+ 6:01:57
3P057	117:45:52	+ 7:00:19
3P065	120:40:00	+ 9:54:27
3P083	123:38:02	+12:52:29
3P102	127:01:56	+16:16:23
3P108	129:33:52	+18:48:19
3P122	132:43:47	+21:58:14
3P133	135:15:43	+24:30:10
3P151	139:03:37	+28:18:04
3P161	141:35:33	+30:50:00

TABLE 2 - k Values and maximum deflection angles for Cell 204 Holograms

	k	maximum deflection angle(milliradians)
3P053	.403 +/- .132	
3P055	.262 +/- .102	5.00
3P057	.186 +/- .024	6.00
3P065	.160 +/- .012	8.50
3P083	.040 +/- .003	9.00
3P102	.026 +/- .003	9.00
3P108	.028 +/- .004	9.00
3P122	.031 +/- .005	10.00
3P133	.024 +/- .003	9.00
3P151	.030 +/- .003	9.00
3P161	.027 +/- .002	8.00

CONCLUSIONS AND RECOMMENDATIONS

In summary, the objectives for the project have been successfully met. The Quantitative Schlieren Analysis Technique produces reliable, reproducible results for the refractive index gradient from the FES flight holograms. Unlike the Mach-Zehnder interferometric method, there are no problems with table vibrations, or thermal air currents over the table. Deviation angles of 0.5 milliradians were recorded and gradients were measured within 0.5 mm of the crystal face. It is quite probable that angles as small as 0.1 milliradians could be recorded. With knowledge of the gradient, iso-concentration lines can be mapped. These lines are very similar in appearance to those obtained for sodium chlorate crystals analyzed under conditions with no gravity induced convection currents perpendicular to the crystal face (Humphreys-Owen, 1949). Using (14) it is possible to find the refractive index on an isoconcentration line and to assign average solute concentration values to these lines. To obtain solute concentrations directly above the crystal requires some type of mathematical manipulation assuming symmetry to the growth process. There has been no attempt during this summer to calculate exact solute concentrations using symmetry assumptions.

Having completed this work there are two recommendations for the future. The first can be implemented with the HGS for better analysis of the holograms and the second recommendation needs to be incorporated into the FES system.

1. A digital image processor must be added to the HGS system. The present system using conventional photography wastes time, manpower, and material. At least one hour is

needed to obtain the data from a hologram, and two to three hours to refine the data. If the image processor and the Unidex positioner were controlled by a computer, data collection time would be reduced by a factor of ten. Computer analysis would produce gradient and solute concentration maps. Each hologram contains more detail than the present process can examine, computer control could reveal the details. With the digital image processor, an operator mounts the hologram, checks the initialization position, and waits for the computer to collect the data.

2. Averaging over the distance through the cell can be avoided by adding optical elements to the FES object beam path that send a set of beams at different angles into the cell. Matching elements on HGS would obtain three dimensional information. One possible system has been used by Buzzard (Buzzard, 1968). A coarse diffraction grating (16 grooves/cm) may be another workable alternative.

Until the image processor is acquired, slow paced data analysis can continue. A detailed investigation of the early growth stages could be made. The time of the first non-symmetric gradients should also be studied. Gradients not related to the seed crystal could yield information about temperature changes and unwanted crystals.

QSAT is a method of holographic analysis that can be extended to any systems where refractive index gradients are present. The hologram reconstructs the wavefronts leaving the test volume and the Unidex controller locates the knife edge with sufficient precision to determine numerical values of the gradients. These gradients may be used to understand processes in the test region.

REFERENCES

- Buzzard, R. D., "Description of three-dimensional Schlieren system", Eighth International Congress on High Speed Photography, 335-340, (1968).
- Davies, T. P., "Schlieren Photography- Review, applications and bibliography", Fifteenth International Congress on High Speed Photography and Photonics, Proceedings Part 2, San Diego, (1982).
- Eckert, E. R. G. and R. J. Goldstein, Measurement of Heat Transfer, Technivision Services, Slough, England, (1970).
- Humphreys-Owen, S. P. F., "Crystal Growth from Solution", Proceedings of the Royal Society, Series A 197, 218-237, (1949).
- Kroes, R. L. and D. Reiss, "Properties of TGS Aqueous Solution for Crystal Growth", Journal of Crystal Growth 69, 414-420, (1984).
- Meyer-Arendt, J. R., Introduction to Classical and Modern Optics, Prentice Hall, Englewood Cliffs, NJ, (1972).
- Owen, R. B. and R. L. Kroes, "Holography on the Spacelab 3 Mission", Optics News, 11, 12-16, (July, 1985).
- TAI Corporation, HGS Users Manual vol. 1 and HGS Technical Operations Manual vol. 2, Contract # NAS8-35426, Huntsville, AL (1984).
- Vasil'ev, L. A., Schlieren Methods, trans. A. Baruch, Israel Program for Scientific Translations, New York, (1971).
- Wolter, H., "Schlieren-, Phasenkontrast- und Lichtschnittverfahren", Handbuch der Physik, S. Flugge, Editor, vol. 24, p.572, Springer Verlag, New York, (1956).