

N87-16755

13-33

25P.

49629

1986

**NASA/ASEE SUMMER FACULTY FELLOWSHIP PROGRAM**

**MARSHALL SPACE FLIGHT CENTER  
THE UNIVERSITY OF ALABAMA**

**AUTONOMOUSLY MANAGED ELECTRICAL POWER SYSTEMS**

<b>Prepared by:</b>	<b>Charles P. Callis</b>
<b>Academic Rank:</b>	<b>Associate Professor</b>
<b>University and Department:</b>	<b>The University of Tennessee at Martin School of Engineering Technology and Engineering</b>
<b>NASA/MSFC:</b>	
<b>Laboratory:</b>	<b>Information &amp; Electronic Systems</b>
<b>Division:</b>	<b>Electrical</b>
<b>Branch:</b>	<b>Electrical Power</b>
<b>MSFC Colleague:</b>	<b>David J. Weeks</b>
<b>Date:</b>	<b>August 1, 1986</b>
<b>Contract No.:</b>	<b>NGT 01-002-099 The University of Alabama</b>

TN908924

# **AUTONOMOUSLY MANAGED ELECTRICAL POWER SYSTEMS**

by

**Charles P. Callis**  
**Associate Professor of Engineering**  
**University of Tennessee at Martin**  
**Martin, Tennessee**

## **ABSTRACT**

The electrical power systems for future spacecraft such as the Space Station will necessarily be more sophisticated and will exhibit more nearly autonomous operation than earlier spacecraft. The additional efforts required for the design, development, and testing of these more autonomous systems will result in the reduction of required components as well as ground support personnel. A reduction in crew involvement will also be realized. Space Station crew members will be able to concentrate more on experiments and mission objectives instead of focusing their attention on power system operations and maintenance. These new power systems will be more reliable and flexible than their predecessors offering greater utility to the users.

This paper will concentrate on automation approaches implemented on various power system breadboards in the Electrical Division of the Information and Electronic Systems Laboratory at Marshall Space Flight Center. These breadboards include the Hubble Space Telescope power system test bed, the Common Module Power Management and Distribution system breadboard, the Autonomously Managed Power System (AMPS) breadboard, and the 20 kilohertz power system breadboard. Particular attention will be given to the AMPS breadboard. Future plans for these breadboards including the employment of artificial intelligence techniques will also be addressed.

## **ACKNOWLEDGEMENTS**

I am honored to have been selected as a summer faculty fellow in the NASA/ASEE summer faculty program. I acknowledge with thanks the smooth and professional administration of the program by Dr. Mike Freeman and Ms. Ernestine Cothran.

I am particularly grateful to Mr. Dave Weeks for sponsoring me in his laboratory for the summer, for the time he has spent with me in the laboratory to involve me in his work, for serving as a visiting lecturer at The University of Tennessee at Martin, and for the encouragement and help he provided so that I might produce an acceptable paper for presentation at the 1986 meeting of the International Energy Conversion Engineering Conference. My teaching, consulting, and research will be improved by the technology exposure I have experienced under Mr. Weeks' guidance and supervision.

I am very appreciative of the help I received and the friendly, cooperative spirit shown to me by all the employees of the Electrical Power Branch.

## LIST OF FIGURES

	<b>Page</b>
<b>Figure 1. MSFC 20 KHZ BREADBOARD</b>	<b>XIII-4</b>
<b>Figure 2. POWER SYSTEM DEVELOPMENT FACILITY</b>	<b>XIII-5</b>
<b>Figure 3. REFERENCE ELECTRICAL POWER SYSTEM DESIGN</b>	<b>XIII-10</b>
<b>Figure 4. AMPS BREADBOARD CONCEPT</b>	<b>XIII-13</b>
<b>Figure 5. AUTONOMOUSLY MANAGED POWER SYSTEM</b>	<b>XIII-14</b>

## TABLE OF CONTENTS

	<b>Page</b>
<b>INTRODUCTION</b>	<b>XIII-1</b>
<b>OBJECTIVES</b>	<b>XIII-6</b>
<b>THE AMPS PROJECT</b>	<b>XIII-8</b>
<b>HISTORY</b>	<b>XIII-8</b>
<b>DEFINITION</b>	<b>XIII-12</b>
<b>SIGNIFICANCE</b>	<b>XIII-15</b>
<b>STATUS</b>	<b>XIII-16</b>
<b>PLANS</b>	<b>XIII-17</b>
<b>CONCLUSIONS AND RECOMMENDATIONS</b>	<b>XIII-18</b>
<b>REFERENCES</b>	<b>XIII-19</b>
<b>ACRONYMS AND ABBREVIATIONS</b>	<b>XIII-20</b>

## INTRODUCTION

Although a relatively new subject of research, 'autonomously managed power systems' has attracted the attention of a number of groups of government employees as well as that of many private companies. A considerable number of speculative publications have been produced over the past five years. Most of the power systems of interest contain three major elements: power generation, energy storage, and the power management and distribution system.

Power generation sources may include photovoltaics, solar dynamic systems, or nuclear systems. Energy storage systems may involve batteries (nickel-cadmium or nickel-hydrogen), flywheels, or regenerative fuel cells. The power management and distribution systems may involve power conversion components, switchgear, load centers with microprocessor controllers, multiple power buses and load buses, circuit breakers, etc.

Researchers continue to speculate on parameters required by future spacecraft power systems. These include power form (alternating current versus direct current), power bus frequency if alternating current, number of phases distributed, voltage level, multiple or single power forms for users, system power level capability, load bus and power bus configurations, and the distribution of controls for the system.

The Autonomously Managed Power System (AMPS) is a proof-of-concept breadboard of an end-to-end high voltage, high power electrical power system. It is based on a multi-hundred kilowatt photovoltaic electrical power system with battery energy storage and distributed load centers. Based on 200 volts direct current, the reference system would deliver 17 power channels with a capacity of 16 kilowatts each. Each of ten load centers would handle 24 kilowatts with remaining power feeding housekeeping payloads directly. The AMPS breadboard is designed for three of the 16 kilowatt power channels feeding two 24 kilowatt load centers. Each load center boasts 10 load channels.

The Hubble Space Telescope (HST) power system test bed is a high fidelity breadboard of the actual HST electrical power system. The test bed contains many flight-type components including the nickel-cadmium batteries, the battery protection and reconditioning circuits (BPRC), and other electronics. A computer interface with the breadboard telemetry determines when an out-of-limits condition occurs for a significant parameter. The computer is connected to an automatic telephone caller which summons test bed personnel to arrive at the test bed site to troubleshoot and correct the malfunction. A fault diagnostic expert system is under development which will troubleshoot the breadboard, identify the malfunctioning component, recommend corrective actions, and print out a report by the time test bed personnel arrive on the scene.

The 20 kilohertz power system breadboard contains a five kilowatt driver module complex coupled to five distinct user modules via two redundant 100 meter transmission lines. This breadboard accepts either alternating current or direct current inputs and can deliver either single phase or three phase 20 kilohertz at 440 volts. The receiver system contains individual modules which produce 28 Vdc, 150 Vdc (as a bi-directional converter), 115 Vac at 60 hertz, 120/208 Vac at 400 hertz, and 120/208 Vac at 800 and 1200 hertz. Actually the last two modules can produce 120/208 Vac at various frequencies between 13 and 3333 hertz. Driver and user switches are controlled by 8086 microprocessors while a Macintosh microcomputer provides an user interface terminal allowing voltage and configuration changes by icon and menu control. (See Figure 1)

The Common Module Power Management and Distribution (CM/PMAD) system breadboard is currently being defined. Most likely, it will accept 20 kilohertz 440 Vac single phase from the 20 kilohertz breadboard. It will likely distribute either 20 kilohertz or possibly 150 Vdc if the Europeans and Japanese persist in their arguments for direct current power in their two modules on Space Station. The CM/PMAD will be a smart system, flexible with fault isolation and recovery capabilities. A great number of automation issues have been under study in order to determine the automation approach for this system.

# MSFC 20 KHZ BREADBOARD

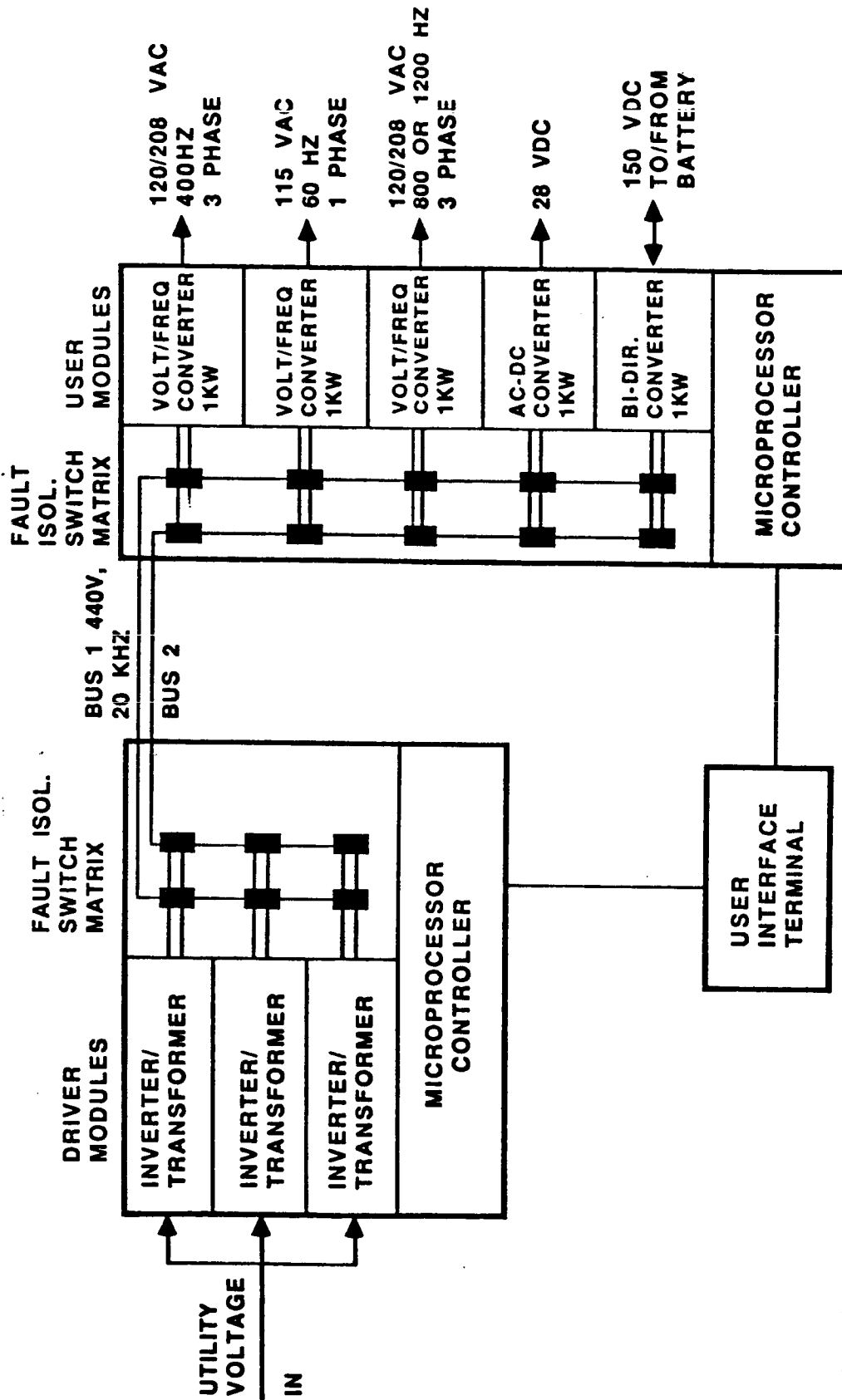

FIGURE 1

**NASA**  
National Aeronautics and  
Space Administration

George C. Marshall Space Flight Center



**The AMPS, 20 kilohertz, and CM/PMAD breadboards will be housed in the MSFC Power Systems Development Facility (see Figure 2). This facility is being employed as a site to consolidate power systems development for future spacecraft. A key element in this development is automation.**

# POWER SYSTEM DEVELOPMENT FACILITY

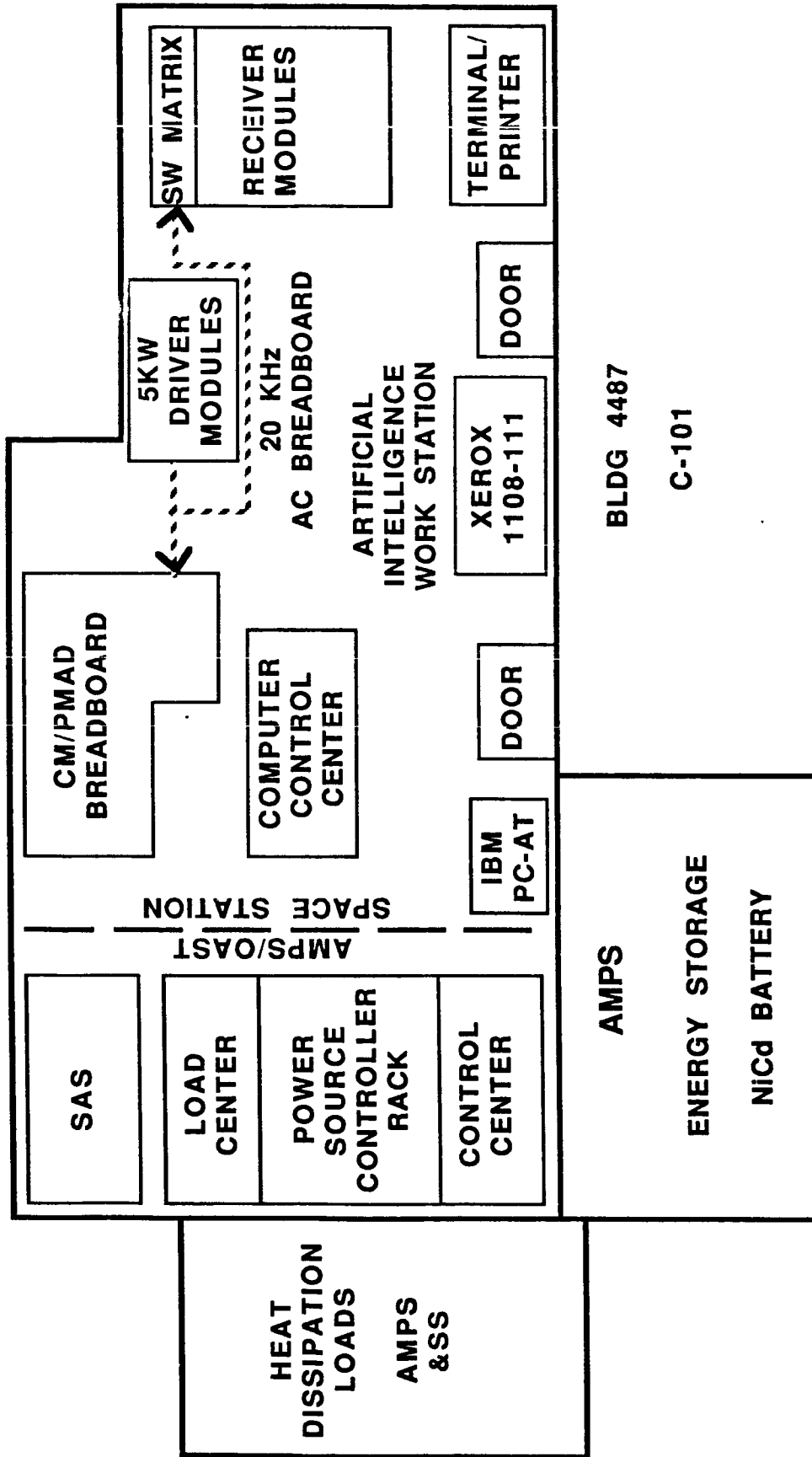

FIGURE 2

## **OBJECTIVES**

The objectives of this work included:

- 1) **Help install the AMPS breadboard at MSFC and prepare for operation by:**
  - a) **aiding in the installation of the major breadboard components**
  - b) **aiding in fabricating and installing interconnecting cables**
  - c) **becoming familiar with the graphics terminals in the host computer environment to prepare for their integration with the breadboard**
  - d) **preparing the breadboard for evaluation of LeRC developed remote power controllers (RPC)**
  
- 2) **Help direct future thrusts in automation of power systems by:**
  - a) **becoming familiar with microcomputer equipment**
  - b) **becoming familiar with existing advanced automation approaches utilized at MSFC including expert systems**
  - c) **becoming somewhat familiar with other existing and planned power system breadboard activities at MSFC**
  - d) **determining potential applications and utilization of AMPS breadboard**
  
- 3) **Assist in the training of a graduate coop by helping him to develop system engineering skills.**
  
- 4) **Make suggestions for gradual development of a more generalized power system breadboard test and evaluation facility.**
  
- 5) **Collect the latest technology applications related to power systems**

**development for dissemination in the electrical power related courses at the University of Tennessee.**

- 6) Become familiar with the NASA procedures for development of flight ready systems: from concept, to specifications, to private contractor to breadboard evaluations, to final product.**
- 7) Learn the evaluation techniques applied to the testing of flight quality electrical power systems.**

## **THE AMPS PROJECT**

My work this summer has primarily been focused on the Autonomously Managed Power System (AMPS) project. The major breadboard components were delivered to MSFC at the end of May, 1986. The breadboard is designed to function as an agency test facility for evaluating new power system components and automation techniques

### **History**

In 1979, the Director of the Power and Propulsion Division of the Office of Aeronautics and Space Technology (OAST) directed MSFC to design an electrical power system with ten times the capacity of any spacecraft power system on the drawing boards at that time.

The program objectives included the development of management and distribution technologies for multi-hundred kilowatt power systems that:

Provide utility-type power by:

- managing a complex multi-channel electrical power system
- accommodating varying power source levels and loads
- improving performance and reliability.

Enable operation with reasonable support requirements.

Reduce development, operation and resupply costs.

Establish specific component technology needs and requirements.

The approach was threefold:

- 1) Identify a reference photovoltaic electrical power system of 250

kilowatts for a low earth orbit (LEO) satellite by:

performing trade studies on cost effective energy storage and power distribution.

2) Developing autonomous power management for reference power system by:

- defining power system philosophies, goals, and operating requirements.
- identifying and developing the algorithms and decision trees necessary to implement these requirements as an autonomous power management subsystem.
- selecting hardware and architecture to perform and implement the management decisions.
- identifying benefits versus cost of autonomy.

3) Defining and developing a test facility that:

- demonstrates a representative portion of the reference 250 kilowatt power system with:
  - three power sources
  - two load centers
  - power subsystem controllers
- integrate power sources, load centers, and power/management controllers that:
  - utilize breadboard equipment where available.
  - utilize simulators where warranted.

Under the direction of the Electrical Power Branch, a reference configuration for a 272 kilowatt electrical power system was developed (see Figure 3). This system is based on Cassegrainian concentrator solar arrays for power generation and nickel-hydrogen batteries or regenerative fuel cells for energy storage. Primary distribution is  $220 \pm 20$  Vdc.

# REFERENCE ELECTRICAL POWER SYSTEM DESIGN

MANAGEMENT OF COMPLEX POWER SYSTEMS USING DISTRIBUTED MICROPROCESSORS LINKED WITH DATA BUS

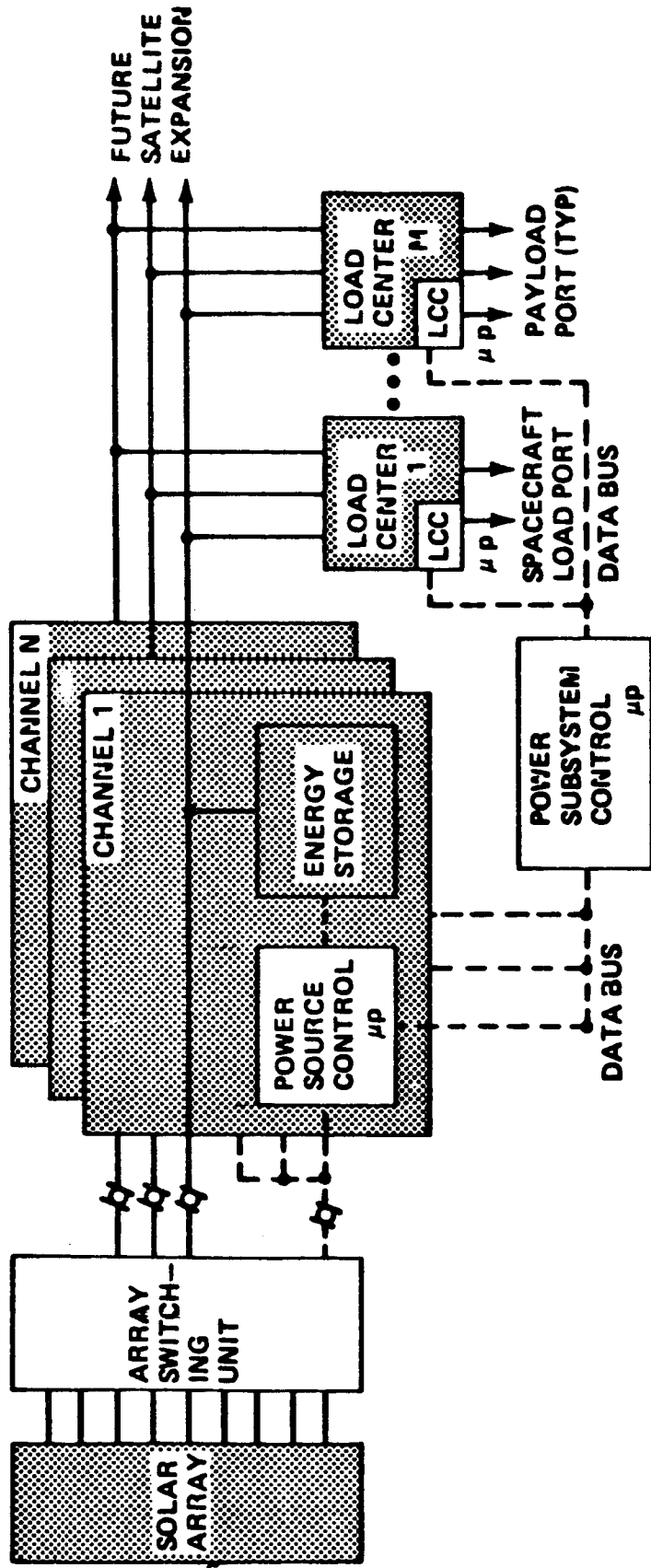

LCC = LOAD CENTER CONTROL  
 μP = DISTRIBUTED MICROPROCESSOR

ORIGINAL PAGE IS  
 OF POOR QUALITY

- GENERATION -- CASSEGRAINIAN CONCENTRATOR SOLAR ARRAY
- ENERGY STORAGE -- FUEL CELL/ELECTROLYSIS OR BATTERIES
- BATTERY CHARGER -- SOLAR ARRAY REGULATION
- REGULATION -- ON ARRAY SWITCHING (200-240 VOLTS)
- POWER TRANSMISSION -- DIRECT CURRENT AT SOURCE VOLTAGE
- POWER DISTRIBUTION -- DIRECT CURRENT AT SOURCE VOLTAGE
- POWER PROCESSING -- AS NEEDED WITHIN EACH PAYLOAD OR LOAD CENTER
- CHANNEL QUANTITY -- DEFINED BY ENERGY STORAGE CAPACITY (17)
- RELIABILITY -- FAIL OPERATIONAL, FAIL SAFE GRACEFUL
- CAPACITY DEGRADATION WITH FAILURES
- LIFE -- INDEFINITE; REPLACE FAILED UNIT AT NEXT SERVICE OPPORTUNITY

FIGURE 3.

About three years were expended studying various trade issues, developing the reference configuration, and generating an automation approach. In 1982, work was initiated on a proof-of-concept breadboard. This breadboard will be defined in the next section.

In 1984, President Reagan commissioned NASA to build a space station within the next decade. The electrical power system development was distributed among the Johnson Space Center, the Lewis Research Center, and the Marshall Space Flight Center. The Lewis Research Center was given the lead role and responsibility for developing the power generation sources and the energy storage components. Johnson Space Center has responsibility for primary distribution while Marshall Space Flight Center is responsible for developing the power management and distribution system for the common modules.

At this point, it appears the primary distribution power form on the Space Station will be 20 kilohertz, single phase. The power generation sources will consist of 25 kilowatts of photovoltaics (flat solar panels) and 50 kilowatts of solar dynamic systems. The distribution within the common modules (two American, one Japanese, and one European) will most likely be 20 kilohertz (single phase) or 150 Vdc (which the Europeans and Japanese prefer). The 20 kilohertz is derived from research efforts by General Dynamics for the Lewis Research Center.

While the initial operating capability (IOC) of the Space Station power system will be 75 kilowatts, the system will grow to 300 kilowatts within ten years of deployment. The automation efforts will be coordinated between the Lewis Research Center and the Marshall Space Flight Center and likely include expert systems for payload management and fault isolation. Such systems will likely coordinate with Johnson Space Center developed system controllers.

Since the Space Station electrical power system development work was divided among three NASA centers and alternating current was selected as the primary power form, the AMPS project was not picked up by the Space Station project. AMPS continues to be a generic agency end-to-end electrical power system.



## Definition

The AMPS breadboard was originally designed to have three power channels and two load centers (see Figure 4). Due to funding restraints from OAST, the breadboard has one power channel feeding three power buses to one load center (see Figure 5).

The breadboard utilizes a 75 kilowatt solar array simulator for the power generation source. This unit is oversized for the task but offers capability for increasing the power channel capacity from 16 kilowatts to about 35 kilowatts. It has remote control capability such that it can be programmed for various orbital simulations.

The energy storage source is a 168 cell nickel-cadmium battery with a capacity of 189 ampere hours. A nickel-cadmium battery was selected because of economics and its approximate simulation of many of nickel-hydrogen battery characteristics.

Three power buses form the transmission lines. These buses lead to the load center which contain ten load buses. Each of the first nine load buses are connected via switchgear to two of the three power buses while the tenth load bus is connected to all three power buses. This was designed to demonstrate maximum flexibility in autonomous management approaches. If one power bus has a fault, load buses can open the switchgear to that power bus while closing the switchgear to engage another power bus.

The loads are resistive while the last load (3 kilowatts) is a pulsed load. The pulsed load pulses between 30 hertz and 20 kilohertz to simulate noise that real loads might put on the buses. The first nine loads may be stepped in increments from 0 volts to the rated value of the load. This stepping may be controlled manually with load center toggle switches or by computer command. This approach is somewhat simplified in that reactive loads are not introduced.

There are three embedded microprocessor-based controllers in the breadboard.

# AMPS BREADBOARD CONCEPT

- 3, 16KW CHANNELS, 48KW TOTAL
- PROVISION FOR UPGRADE TO 30-35KW PER CHANNEL
- POWER PROFILE AND ECLIPSE SIMULATION.

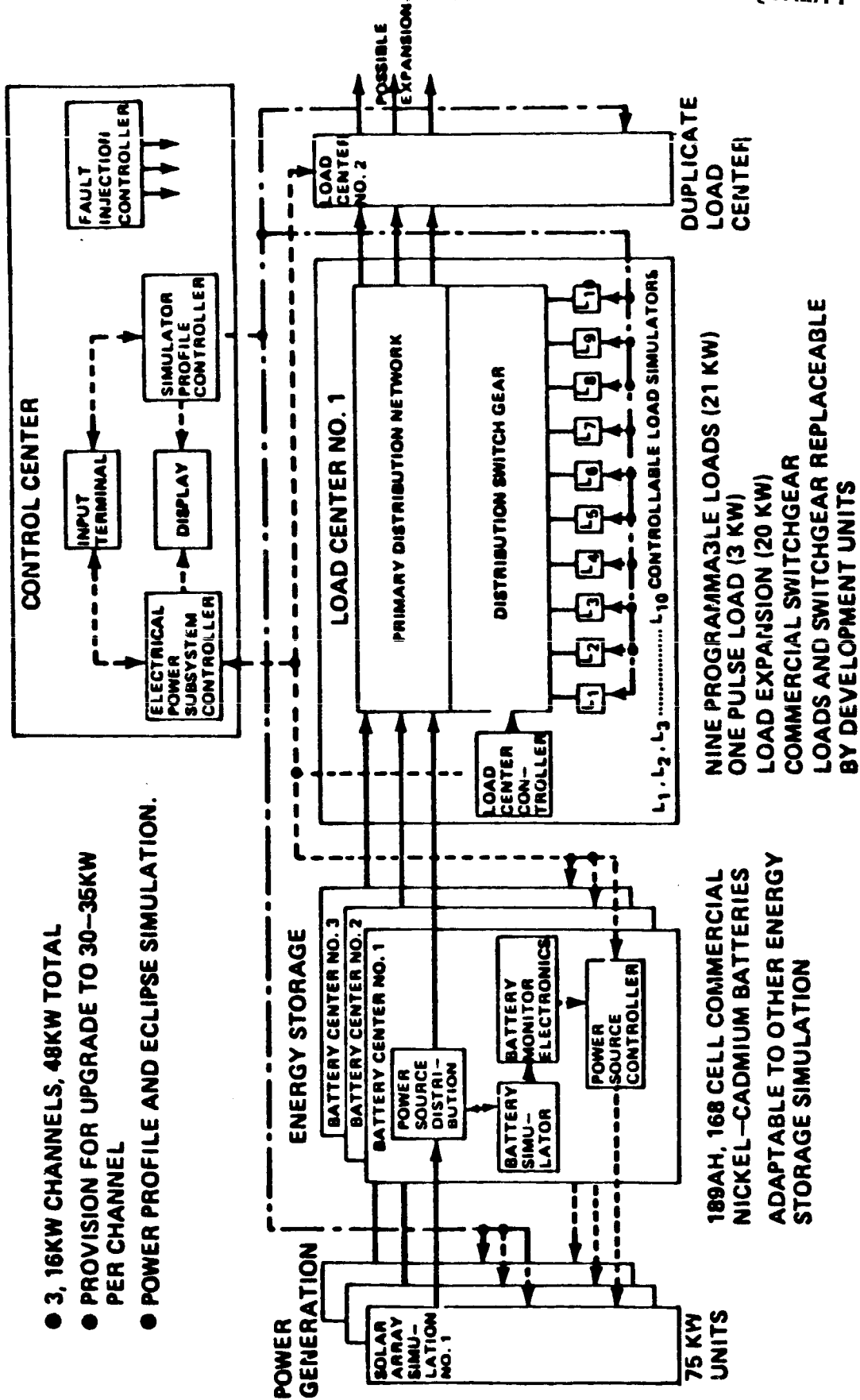

ORIGINAL PAGE IS OF POOR QUALITY

FIGURE 4

# AUTONOMOUSLY MANAGED POWER SYSTEM

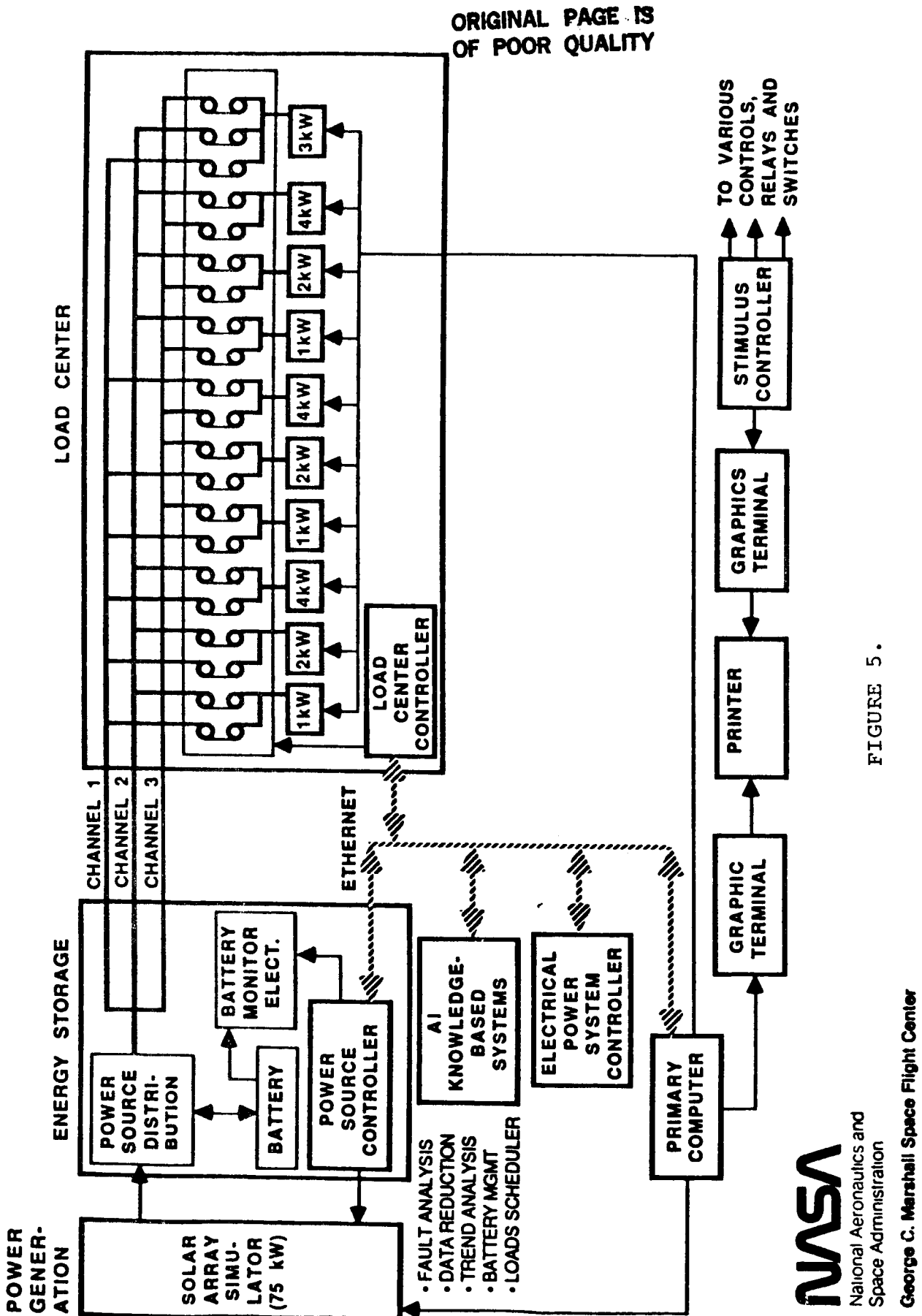

ORIGINAL PAGE IS OF POOR QUALITY

FIGURE 5.

**NASA**  
National Aeronautics and  
Space Administration

George C. Marshall Space Flight Center

The power source controller controls the power generation source (solar array simulator) and the energy storage source (battery) as well as the associated electronics. The load center controller controls the various loads and switchgear. The electrical power system controller acts as an interface to the outside world and in a multi-channel, multi-load center system would control the various load center and power source controllers. The controllers are 68000 processor based and are networked via an Ethernet local area network.

A host computer environment is interfaced to exercise the breadboard. The primary computer is a NCR Tower XP model that is also connected to the Ethernet network. This computer also interfaces with the solar array simulator and with the loads in order to introduce various operational scenarios such as changing the day/night orbit times and the system voltage levels as well as load levels. The primary computer is also interfaced with a Tektronix 4125P color graphics computer to display system status, schematics, block diagrams, etc.

A stimulus controller interfaces with the loads, the solar array simulator, and various relays embedded in the breadboard to simulate different faults in the system. This controller is also a NCR Tower XP and it interfaces with a Tektronix 4105A color graphics computer to display schematics and block diagrams which pinpoint potential faults which may be injected by keyboard command. The stimulus controller does not interface with the Ethernet network. Faults may be injected into the breadboard via the stimulus controller system and the response of the system may be observed on the primary computer system. Both color graphics terminals interface with a Tekronix 4691 color ink jet printer.

### Significance

This breadboard is the only generic end-to-end direct current electrical power system breadboard/test facility in the agency. It provides a test bed and demonstration system that will verify power management strategies, verify the performance of technology hardware such as new power converters and remote power controllers (switchgear), and provide a continuing vehicle for verification of new technology and power system component performance.

Some of the design drivers for the power management include complexity of 50 to 500 kilowatt, multi-channel power subsystems; power management must be flexible and adaptable to varying power levels consistent with modular growth in power system capability; main power bus compatibility with future undefined users through load center control flexibility; rapid reaction time to anomalies independent of ground station activity; and "user friendly" utility type interface.

### Status

As mentioned earlier, the breadboard components were delivered to MSFC at the end of May 1986. These components were developed or procured by TRW in Redondo Beach, California. The host computer environment is being developed at MSFC. The breadboard was tested at TRW and demonstrated autonomous load balancing which extends the lifetimes of power conversion and distribution components.

The power channel including the power generation source, the energy storage system, and the three power buses have been completed. Some of the algorithms for the power source controller have been completed including the battery cell scanner data acquisition. Other power source controls including energy storage charge control and energy storage state of health are under development. Several of the power distribution controls including fault/anomaly recognition, fault/anomaly recovery, load center state of health, and power processor control and monitor have been completed. Subsystem fault/anomaly recognition and recovery have also been completed.

Software controls remaining to be accomplished include subsystem energy planning and allocation, power system trend analyses, power source solar array status and state of health, power source switchgear control and monitor, and various spacecraft interface simulation software for the host computer system.

The host computer system must still be interfaced with the breadboard. This includes installing the primary computer as a node on the Ethernet network, installing the stimulus controller, and connecting the primary computer to the

solar array simulator and to the loads. The stimulus controller must also be interfaced with the solar array simulator and the loads. Various relays must be installed in the actual breadboard to simulate different fault conditions. The stimulus controller will then have to be interfaced with these relays.

Although the pulsed load has been developed, it must also be interfaced with the load center and host computer system. These activities are expected to be completed over the next 15 months although refinements will continue to be made.

### Plans

The breadboard is being readied for evaluating MOSFET remote power controllers developed at the Lewis Research Center. This evaluation should begin in the next few months and will continue for about a year.

The Electrical Power Branch has been engaged in the development of expert system applied to other electrical power system breadboards. Proposed plans call for the application of expert systems to AMPS for fault analysis, data reduction, trend analysis and component failure forecasting, battery management, and dynamic loads scheduling.

## **CONCLUSIONS AND RECOMMENDATIONS**

The four power system breadboards discussed in this paper represent considerable advancement in autonomously operated electrical power systems for space. Much of the technology developed in the effort will remain generally useful and applicable in a test bed layout for evaluations of space power systems yet undeveloped.

Thought should be given to the further development of the laboratory test beds which would permit easier and faster testing of various configurations and designs of future systems. The physical facility could be developed and enhanced such that its cable arrangements providing external power, its host computer services, its selection of static and dynamic loads, etc., would provide a setting wherein new system installation and data acquisition could be greatly facilitated.

Further testing capability should be considered for the test bed facility to permit the following tests and measurements:

1. Electromagnetic interference generated by any test package.
2. Coordination of fault interruption circuits and devices.
3. Operate time and cycle lifetimes of fault interruption equipment.
4. Measurement of personal shock currents allowed by life-protect fault interruption equipment (GFI fast operate circuits).
5. Quality of regulated power produced from bus of system in test.

## REFERENCES

Bechtel, R.T. and D.J. Weeks, "Autonomously Managed High Power Systems", Proceedings of the 20th IECEC, 164-170 (1985).

Lepisto, J.W., "Autonomously Managed Electrical Power System", to be published in the Proceedings of the 21st IECEC (1986).

Weeks, D.J., "Application of Expert Systems in the Common Module Electrical Power System", Proceedings of SPIE, Volume 580, Space Station Automation (1985)

Final Report: Space Power Distribution System Technology, TRW Report No. 34579-6001-OT-00, Volumes 1-3, Contract NAS8-33198, March 1983.



## **ACRONYMS and ABBREVIATIONS**

<b>ac</b>	<b>alternating current</b>
<b>AI</b>	<b>artificial intelligence</b>
<b>AMPS</b>	<b>autonomously managed power system</b>
<b>ASEE</b>	<b>American Society of Engineering Education</b>
<b>BI-DIR</b>	<b>bi-directional</b>
<b>BPRC</b>	<b>battery protection and reconditioning circuit</b>
<b>CM/PMAD</b>	<b>common module/power management and distribution</b>
<b>dc</b>	<b>direct current</b>
<b>GFI</b>	<b>ground fault interrupter</b>
<b>HST</b>	<b>Hubble Space Telescope</b>
<b>Hz</b>	<b>hertz</b>
<b>IOC</b>	<b>initial operating capability</b>
<b>kHz</b>	<b>kilohertz</b>
<b>kW</b>	<b>kilowatts</b>
<b>LEO</b>	<b>low earth orbit</b>
<b>LeRC</b>	<b>Lewis Research Center</b>
<b>MOSFET</b>	<b>metallic oxide semiconductor field effect transistor</b>
<b>MSFC</b>	<b>Marshall Space Flight Center</b>
<b>NASA</b>	<b>National Aeronautics and Space Administration</b>
<b>NiCd</b>	<b>nickel cadmium</b>
<b>OAST</b>	<b>Office of Aeronautics and Space Technology</b>
<b>RPC</b>	<b>remote power controller</b>
<b>SAS</b>	<b>solar array simulator</b>
<b>SS</b>	<b>Space Station</b>
<b>SW</b>	<b>switch</b>