

N87-17782**AMTEC: HIGH EFFICIENCY STATIC CONVERSION FOR SPACE POWER**

C. P. Bankston and M. Shirbacheh
California Institute of Technology
Pasadena, CA

ABSTRACT

Future manned and unmanned space missions will require reliable, high efficiency energy conversion systems. For a manned Mars mission, power levels in the range 10kWe-100's kWe will be needed. The Alkali Metal Thermoelectric Converter (AMTEC) is a new direct energy conversion technology with the potential to meet these needs. It's characteristics include compactness, light weight, reliability and simplicity (no moving parts), and modularity, where efficiencies of 20-40% have been predicted. AMTEC is a thermally regenerative electrochemical device that derives its operation from the unique sodium ion conducting properties of beta-alumina solid electrolyte (BASE). It's high temperature operating range, 900 K-1300 K, makes it well suited for space power heat sources. To date, an efficiency of 19%, area power density of 1 W/cm^2 , and a lifetime of 10,000 hrs at high temperature have been demonstrated in laboratory devices. Systems studies show that projected AMTEC systems equal or surpass the performance of other static or dynamic systems in applications of 1 kWe-1 MWe. Thus, the laboratory experiments and applications studies conducted to date have shown that the AMTEC possesses great potential. In order to bring this technology to the stage where prototype units can be built and operated, several technical issues must be addressed. These include the need for long life, high power electrodes, minimization of radiative parasitic losses, and high temperature seals. In summary, the evidence shows that if the AMTEC is developed, it can play a significant role in future space power applications.

INTRODUCTION

A manned Mars mission (MMM) will require a reliable high efficiency power conversion system that can provide electrical power in the 10 kWe-100's kWe range. The conversion system also has to be adaptable to a variety of energy sources (nuclear, solar and isotope) to be useful for various phases of the mission. The MMM will probably consist of mission module, lander and rover and can evolve to a permanent base on Mars. The electrical power requirements can vary from tens of kilowatts for the

lander to 100's of kilowatts for a base. The lifetime of the power conversion system should be in the 7-10 year range to accommodate the various mission scenarios. Reliability of the conversion system is especially important for the manned missions, and redundancy in components or the total system has to be offered. Low mass is always an important factor in space power. It becomes even more important for MMM because of the large ratio of mass required in Low Earth Orbit (LEO) to that delivered to the surface of Mars. The conversion system also has to have a small area/volume, especially if aerocapture for Mars landing or the Earth return is employed.

It is desirable for a power conversion system to meet the above criteria as well as other mission peculiar requirements and considerations. Previous NASA missions, with the exception of short duration missions (e.g., Apollo, Space Shuttle) that used fuel cells, have usually taken advantage of static conversion systems (e.g., photovoltaic, thermoelectric). Static conversion systems are modular, reliable and have a moderate specific power. However, they offer a low energy conversion efficiency (7-10%) which in view of high fuel cost, makes them less attractive. Dynamic conversion systems, on the other hand, offer higher conversion efficiencies, but a mass penalty has to be paid to make them redundant and reliable. This is particularly true for power levels less than ~25 kWe. A system that promises to offer the advantages of both static and dynamic conversion systems is the Alkali Metal Thermoelectric Converter (AMTEC), a system with the modularity and reliability of static conversion systems.

The AMTEC is a thermally regenerative electrochemical device for high efficiency, direct thermal to electrical energy conversion.^(1,2) Its operation derives from the unique sodium ion conducting properties of beta-alumina solid electrolyte (BASE).⁽³⁾ The AMTEC accepts heat at 900-1300 K and rejects heat in the range 400-800 K, with predicted device efficiencies of 20-40%.⁽⁴⁾ These projected efficiencies are much higher than any other direct thermoelectric device. To date, an efficiency of 19%⁽⁵⁾ and an area power density of 1 W/cm²⁽⁴⁾ have been demonstrated in laboratory devices.

Among the AMTEC characteristics that make it potentially attractive for space applications are compactness, light weight, reliability and

simplicity (no moving parts) and modularity. Since the high temperature sodium reservoir may be heated externally, the AMTEC may be coupled with chemical, nuclear or solar heat sources. The high temperature range is well suited for current and projected space power heat sources. Its high efficiency and light weight would provide high specific power (W/kg), and radiator area would be minimized. Modular units could be designed to produce efficient power generation over a range of power system sizes. Also, a particular AMTEC system could be operated at reduced power levels without large drops in efficiency during periods of low demand.

A comprehensive technical review of thermally regenerative electrochemical systems, including AMTEC, was carried out by the Solar Energy Research Institutes for DOE.⁶ It found that the AMTEC (or sodium heat engine) has potentially the highest power density and efficiency of such systems. Thus, the characteristics and potential of the AMTEC make it a candidate for a variety of applications, including space and remote power.

PRINCIPLES OF OPERATION

The operating cycle of the AMTEC is illustrated in Figure 1. A closed vessel is divided into a high-temperature/pressure region in contact with a heat source and a low-temperature/pressure region in contact with a heat sink. These regions are separated by a barrier of BASE which has an ionic conductivity much larger than its electronic conductivity. The high-temperature/pressure region contains liquid sodium at temperature T_2 , and the low-pressure region contains mostly sodium vapor and a small amount of liquid sodium at temperature T_1 . Electrical leads make contact with a porous (positive) electrode which covers the low pressure surface of the BASE and with the high temperature liquid sodium (negative electrode). When the circuit is closed, sodium ions are conducted through the BASE due to the difference in vapor pressures (or chemical activity) across the BASE, while electrons flow to the porous electrode surface through the load, producing electrical work. The unique feature of the AMTEC cycle is that sodium vapor is expanded nearly isothermally through the BASE, causing the sodium atoms to separate into sodium ions and electrons. The AMTEC thus converts the work of isothermal expansion of sodium vapor directly to electric power.

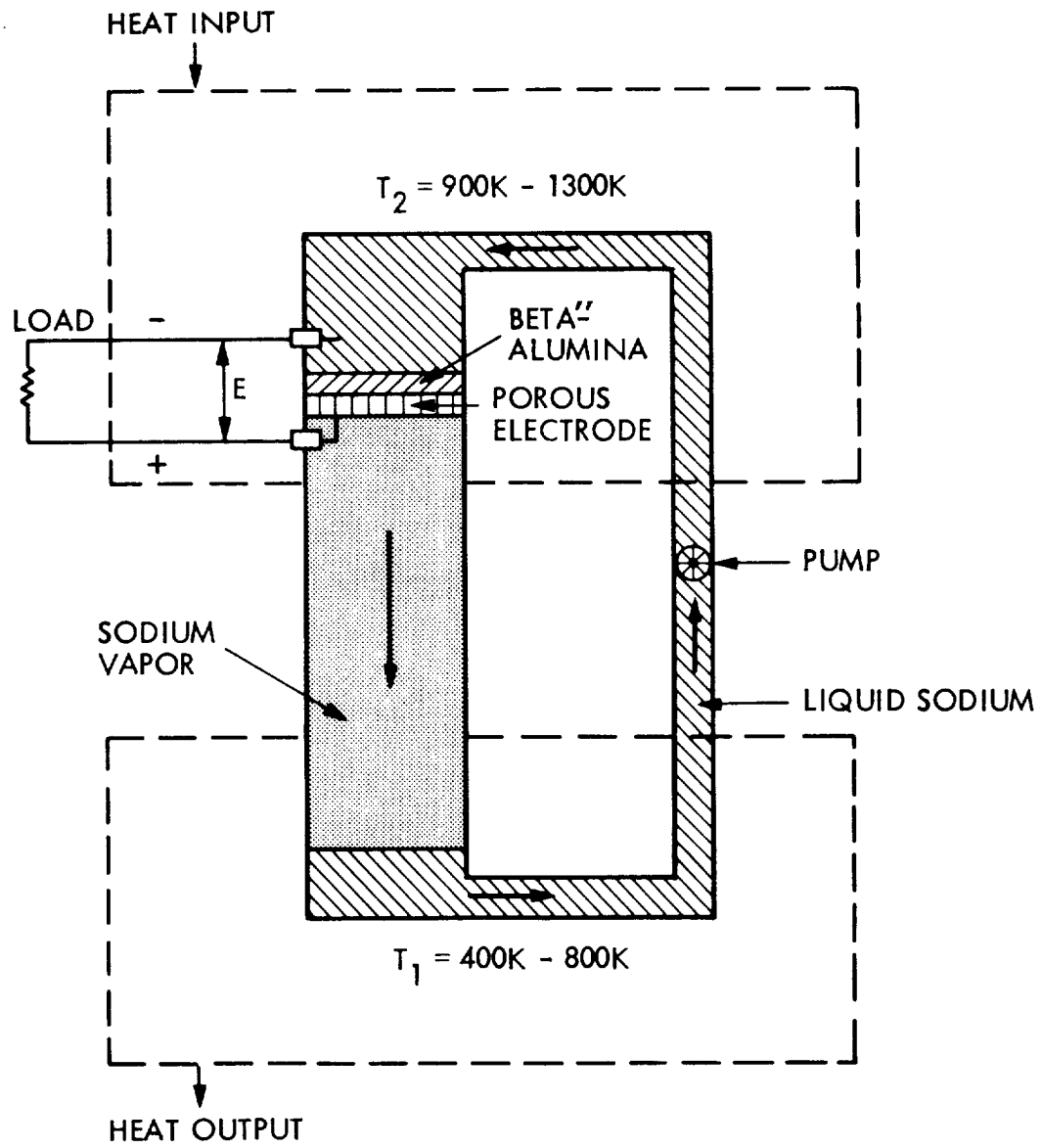

Figure 1. AMTEC Schematic

A return line and an electromagnetic pump (no moving parts) circulate the sodium working fluid through the AMTEC. Complete details on the AMTEC cycle may be found in References 1, 2, 4 and 7.

The operating characteristics and system performance may be determined from AMTEC voltage vs. current characteristics:

$$V = A - B \ln(I + \delta) - I h r_0, \quad (1)$$

where A, B and δ depend on temperatures T_1 and T_2 , and r_0 is the resistivity of the BASE which is also dependent on T_2 . I is current density in A/cm^2 and h is BASE thickness in cm. The relationship for A, B, δ and r_0 are given in Ref. 7. Equation (1) is derived from kinetic theory and an equation relating pressure and the rate of evaporation of sodium atoms from the low pressure hot surface. (2,4) Representative voltage vs. current curves for different temperatures are shown in Figure 2.

AMTEC efficiency is given by:

$$\eta = IV / [IV + I(L + C(T_2 - T_1)/F + Q_{loss})], \quad (2)$$

where L is the latent heat of vaporization for sodium, C is the average specific heat of liquid sodium, and F is the Faraday. Q_{loss} is the sum of parasitic conductive and radiative heat losses. This quantity depends on the specific AMTEC design and should be minimized in any practical device. Its effect on system performance is illustrated in Figure 3. Note that both power output and parasitic losses scale with electrode area. The AMTEC thus lends itself to modular design, since efficiency will be relatively independent of size (or output).

TECHNOLOGY STATUS

Work on the AMTEC concept has to date predominantly been directed toward the development of a long life, high power porous electrode. State-of-the-art electrodes are composed of either magnetron sputter-deposited molybdenum (1-3 μ m thick) or of bi-conductor cermet composed of a mixture of molybdenum and BASE powders. For the cermet electrode, power densities are very low initially, but have been observed to be stable for up to approximately 10,000 hours. (8) In the case of the thin film molybdenum electrode, the data show that power densities are initially high (near theoretical), followed by a decay by a factor of 3-5 in the first 1000 hours of operation. Power output usually remained stable thereafter. However, more recent studies at JPL indicate that the high initial power densities for thin electrodes may be explained by certain

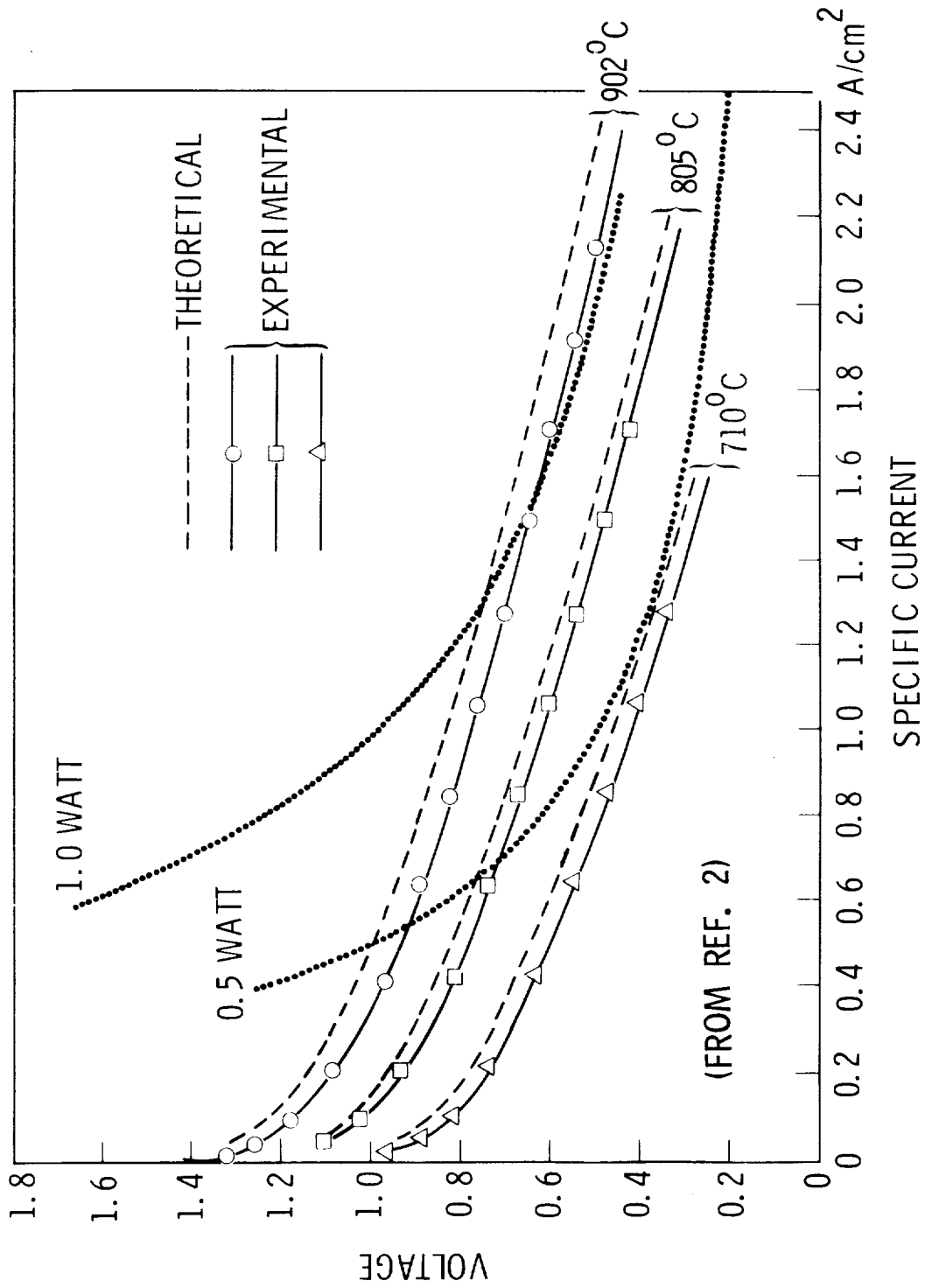

Figure 2. AMTEC: Voltage vs Current

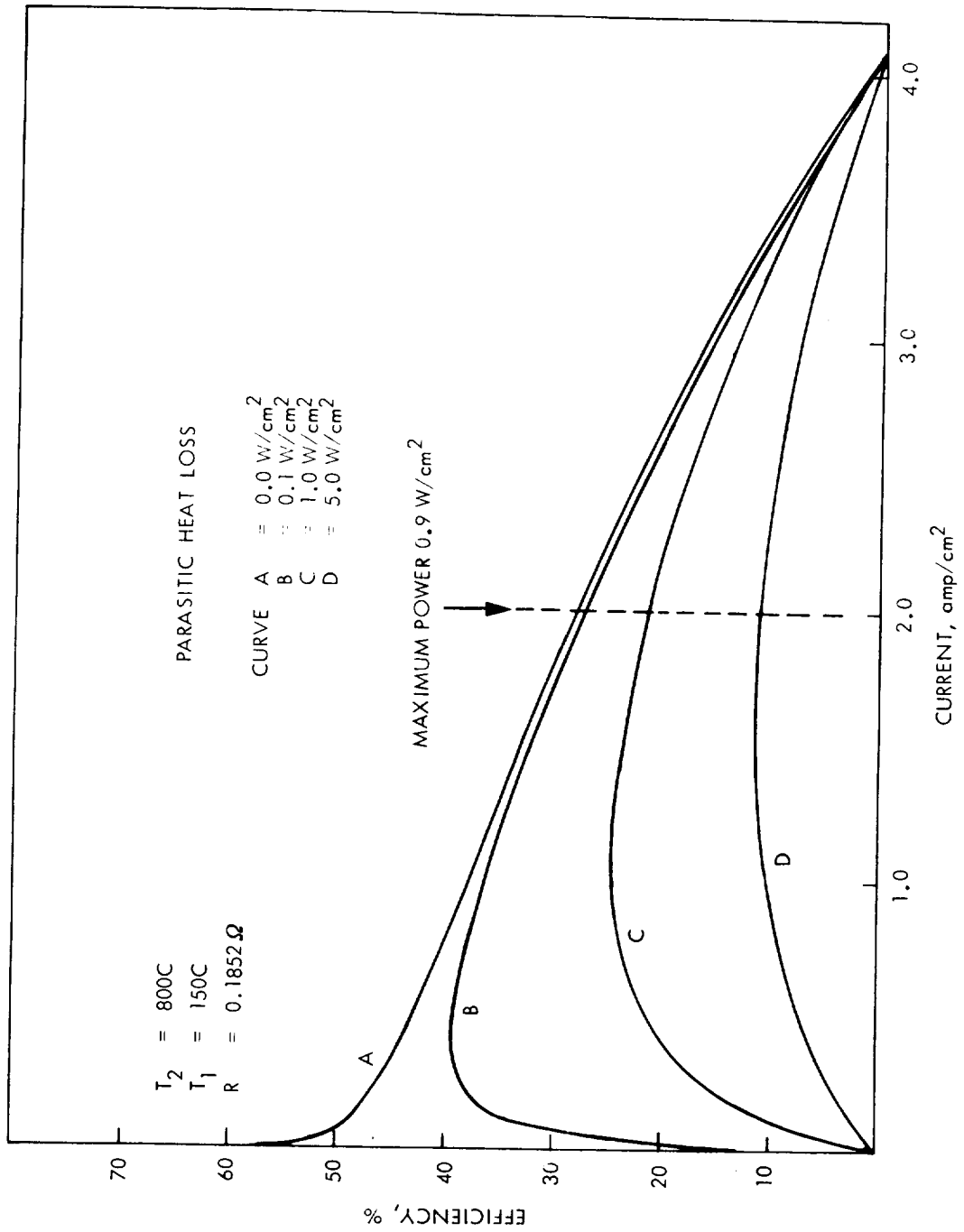

Figure 3. Efficiency vs Current

electrochemical mechanisms and that the high power lifetime may be restored and extended by oxygen treatment of deposited Mo electrodes.⁽⁹⁾

As mentioned previously, recirculating devices have been built which have demonstrated relatively high efficiency⁽⁵⁾ and more recently long lifetime potential (10,000 hours).⁽⁸⁾ A single cell recirculating device schematic is shown in Figure 4. Also, series connection of AMTEC cells has been demonstrated.⁽⁸⁾

SYSTEM STUDIES

System studies of the AMTEC have been carried out at JPL for space power applications (7,9,10) over a wide range of power levels (1-10,000 kW). In the concept designs studied by Bankston, et al.,^(7,9) the results (Figure 5) show that small radioisotope space power systems (~1kW) would operate at an efficiency and specific power (W/kg) which is 3-4 times the currently utilized Seebeck effect generators. For larger nuclear reactor based systems (1000kW), AMTEC projections equal or surpass efficiency and mass characteristics of both the static (thermoelectric, thermionic) and dynamic (Brayton, Rankine, Stirling) system projections. The AMTEC would also allow the nuclear reactor to be operated at lower temperatures than most other conversion options. Ewell⁽¹⁰⁾ extended these projections to the 1MW level and found the AMTEC to be very competitive with the static and dynamic systems. In the most recent study,⁽¹¹⁾ it was found that if the AMTEC is developed, it would be the preferred power converter for an unmanned Mars rover.

Preliminary solar energy system projections were carried out at Ford by Subramanian and Hunt.^(12,13) They calculated that with a "near term" AMTEC technology, a point focused system would achieve a converter-receiver efficiency of 25%, and with advanced technology, 33%. In an AMTEC/Rankine cycle topping/bottoming system combination, estimated efficiencies would increase to 37% and 45 % for near term and advanced levels. These efficiencies are highly competitive with alternate technologies. Recently, in a study for the Department of Energy,⁽¹⁴⁾ Sandia National Laboratories ranked the AMTEC first among heat engine technologies with the potential to meet DOE's long-term goals for dish electric solar systems.

In the transportation sector, the AMTEC has been proposed as a prime power source and as the battery charger in an AMTEC-battery hybrid elec-

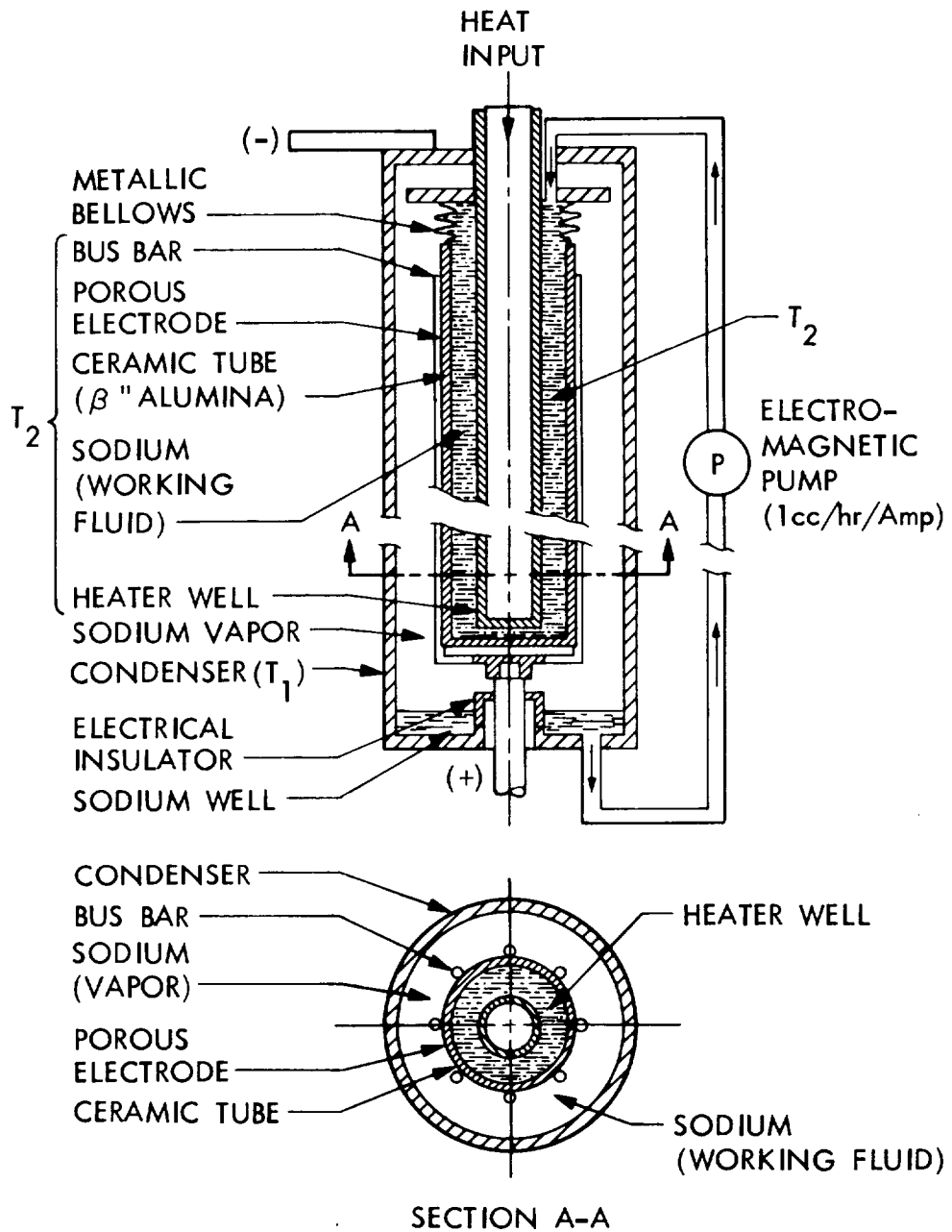
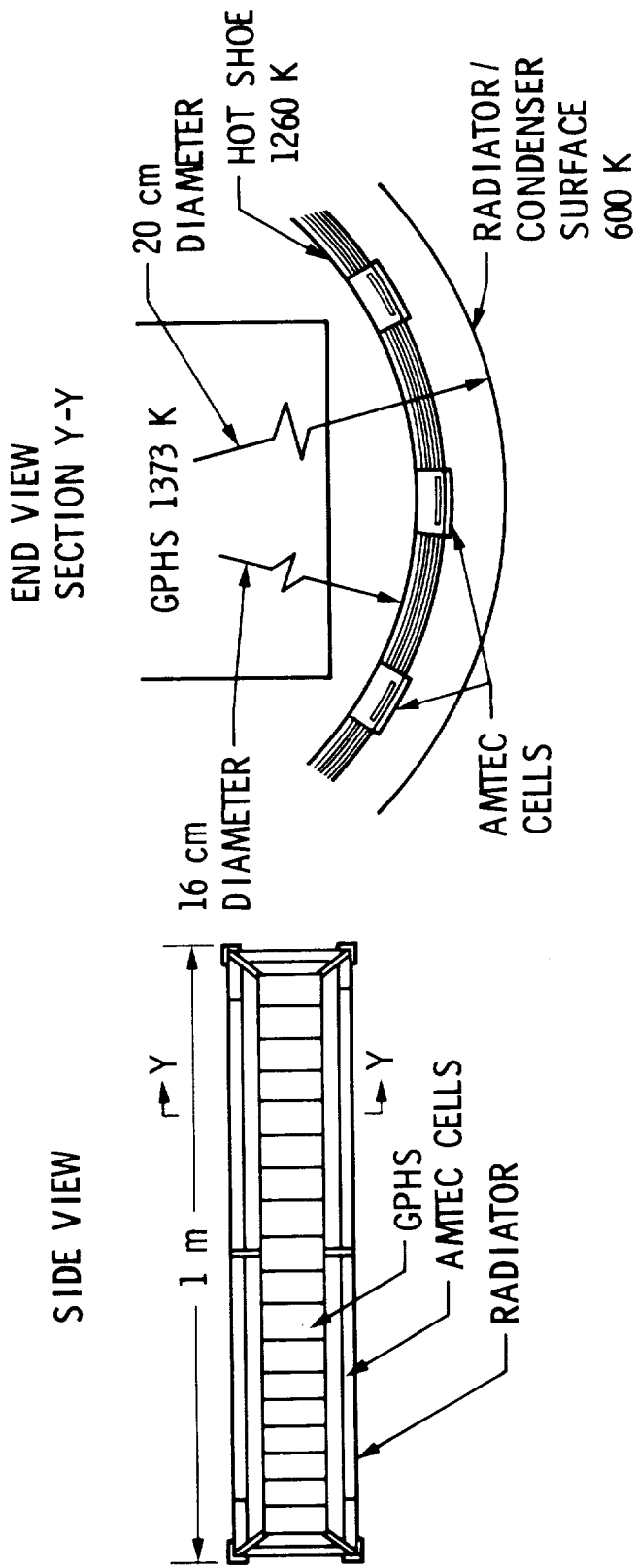

Figure 4. AMTEC Recirculating Test Cell



- AMTEC POWER SOURCE NEARLY IDENTICAL TO GPHS RTG CONFIGURATION, DIMENSIONS, AND MASS---PROJECTED OUTPUT POWER IS MORE THAN TRIPLED BECAUSE OF INCREASED EFFICIENCY
- BASELINE DESIGN HAS A MASS OF 55 kg AND PROJECTED OUTPUT POWER OF 890 W => SPECIFIC POWER 16.2 W/kg; SPECIFIC POWER BASED ON DEMONSTRATED LABORATORY PERFORMANCE IS 14.7 W/kg (SOA GPHS RTG 5.2 W/kg)

Figure 5. AMTEC Radioisotope Power Source Concept

tric vehicle. As a primary power source, the compactness (~ 0.5 kW/liter) of the AMTEC makes it a potential competitor for >1MW electric drives for locomotives or other large land vehicles. In a hybrid system, a well engineered AMTEC should be able to generate direct current at high efficiency for battery charging.

COMPARISON OF AMTEC WITH OTHER POWER CONVERSION SYSTEMS

As mentioned earlier, AMTEC offers efficiencies and specific power (kW/kg) better than (in the 1-100 kWe range) or comparable (in the 100 kWe-1 MWe range) to dynamic conversion systems. This is illustrated in the following figures. Figure 6 shows the radiator area requirement for various power conversion systems. The radiator area requirement for AMTEC is lower because of its high temperature heat rejection. Figure 7 shows the efficiencies of various conversion systems. The figure shows the efficiencies for intermediate technology (dashed lines) and advanced technology. The basic difference between the two technologies is the hot side temperature. Figure 8 shows the total system mass for various conversion systems in the 1-100 kWe power range. The numbers in the 1 kWe range are the system studies that have been performed by various organizations (7,15,16,17), and the 100 kWe numbers are the result of SP-100 system studies. Figure 9 shows the same comparison for 100 kWe-10 MWe power ranges.

TECHNICAL ISSUES

The laboratory experiments and applications studies conducted to date have shown that the AMTEC concept possesses great promise. However, it is still at an early stage of development, relative to more mature energy conversion devices. Thus, a significant technology development effort will be required before prototype units can be tested. Work to date has led to the conclusion that to bring the AMTEC to a state of technical maturity, several key issues must be resolved.

(a) The porous electrode is crucial to the operation of the AMTEC. To date, high power density operating periods of 300-1000 h have been achieved. Recent experimental work has resulted in regeneration of degraded electrodes and led to an understanding of electrode degradation mechanisms. Continued work on stabilizing electrode performance is needed to extend lifetimes to 10,000 h or more.

(b) The efficiency equation for the AMTEC shows that parasitic heat loss by radiation from the porous electrode to the condenser must be tightly controlled to achieve 20-40% efficiency. A smooth film of liquid sodium on the condenser surface would meet this requirement. Thus, materials or surface treatments that will insure a smooth film on the condenser surface must be identified. Also, if operated in zero-g, this condenser must also be capable of collecting and transporting sodium for recirculation.

(c) Operation of the AMTEC for thousands of hours will require several high quality ceramic to metal and metal to metal seals in the high temperature zone. State-of-the-art techniques have been demonstrated for short term testing; however, durable, long life integrity must be demonstrated.

(d) Control circuitry and optimum power/voltage conversion components must be developed.

(e) What are the effects of thermal, electrical and mechanical transients on the durability of the device? Testing must be conducted.

(f) The initial design studies have shown that the AMTEC would provide significant performance advantages in space power applications. However, design optimizations have not been carried out, particularly with respect to coupling with appropriate heat sources.

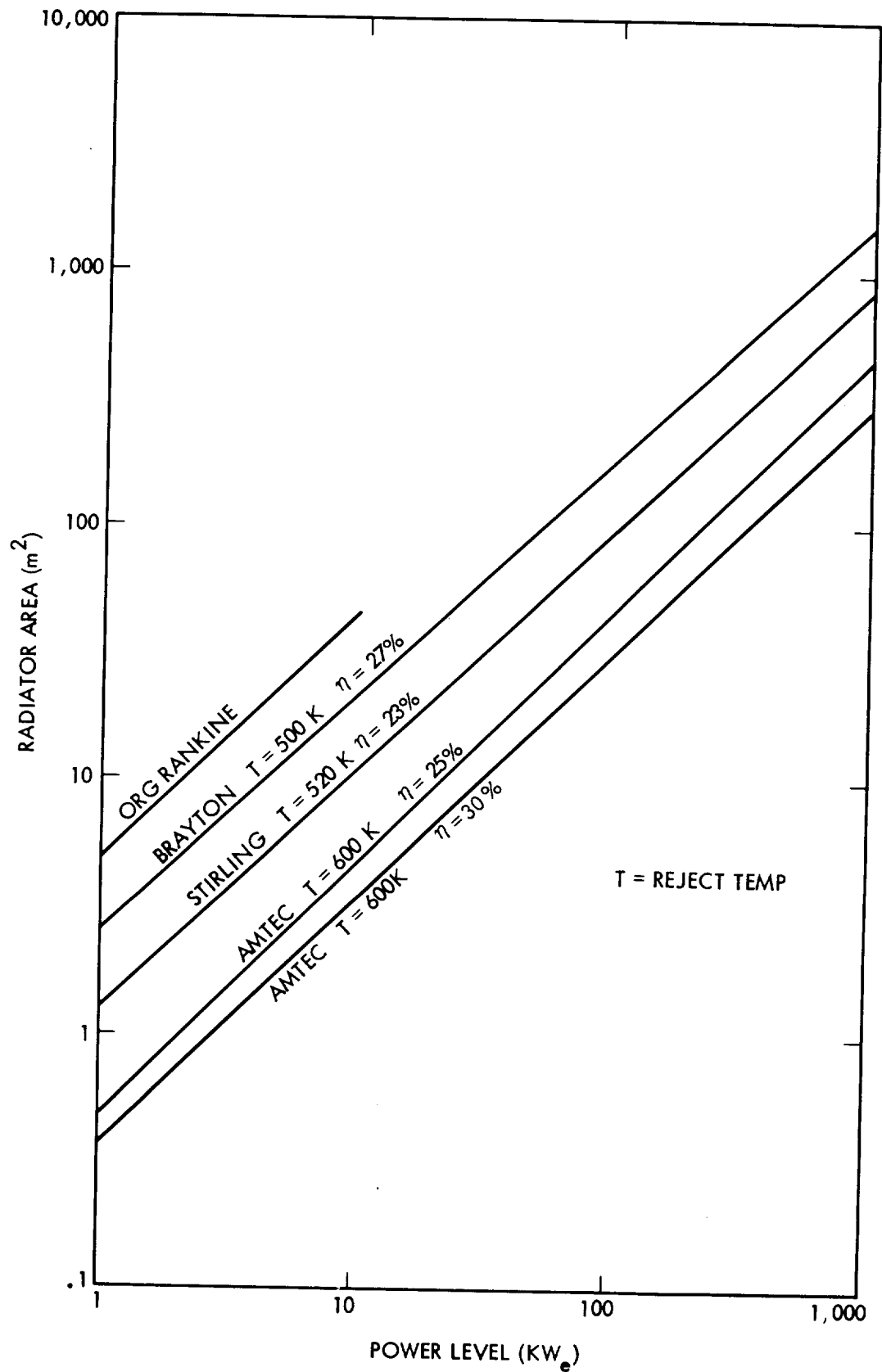

Figure 6. Radiator Area vs Power

T_t = TURBINE INLET
 T_e = EMITTER
 T_h = HOT SHOE
 T_s = SODIUM TEMP

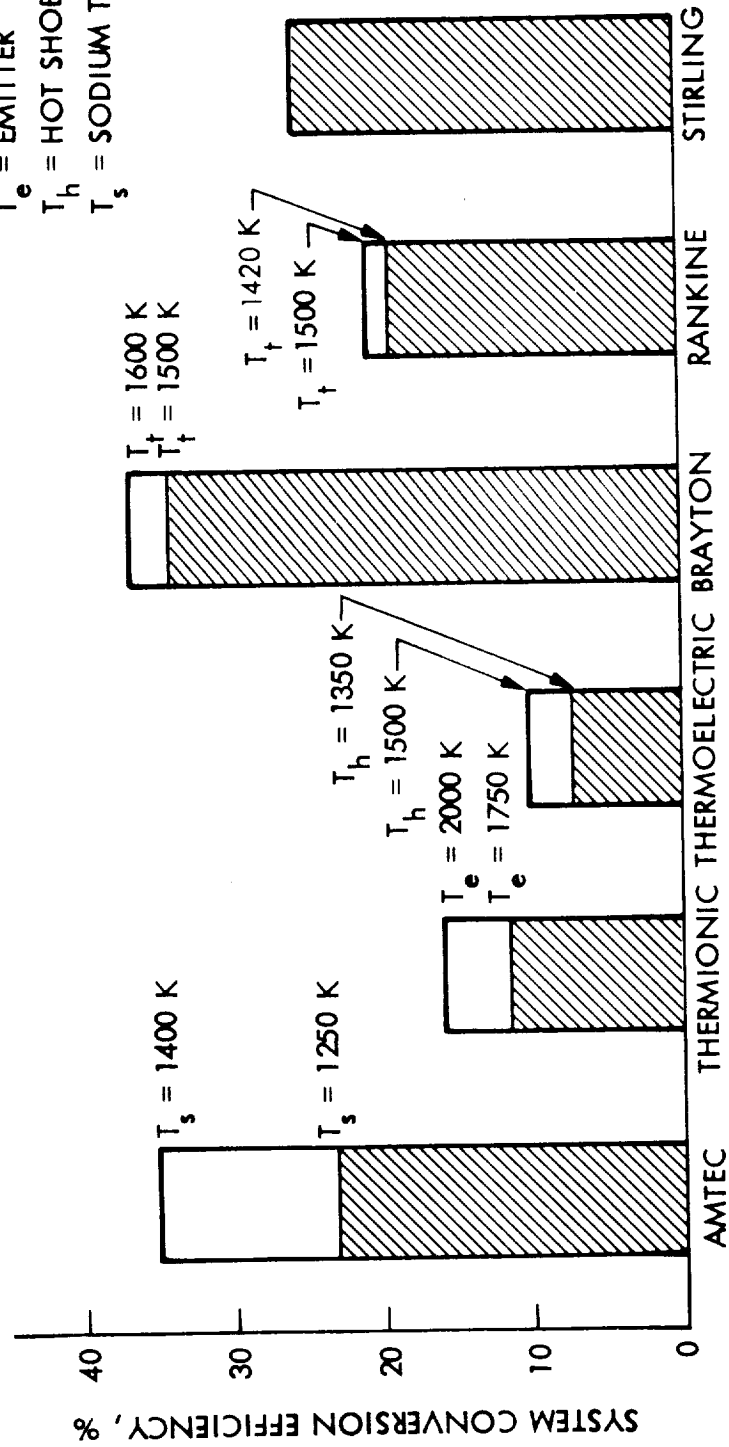

Figure 7. System Conversion Efficiencies

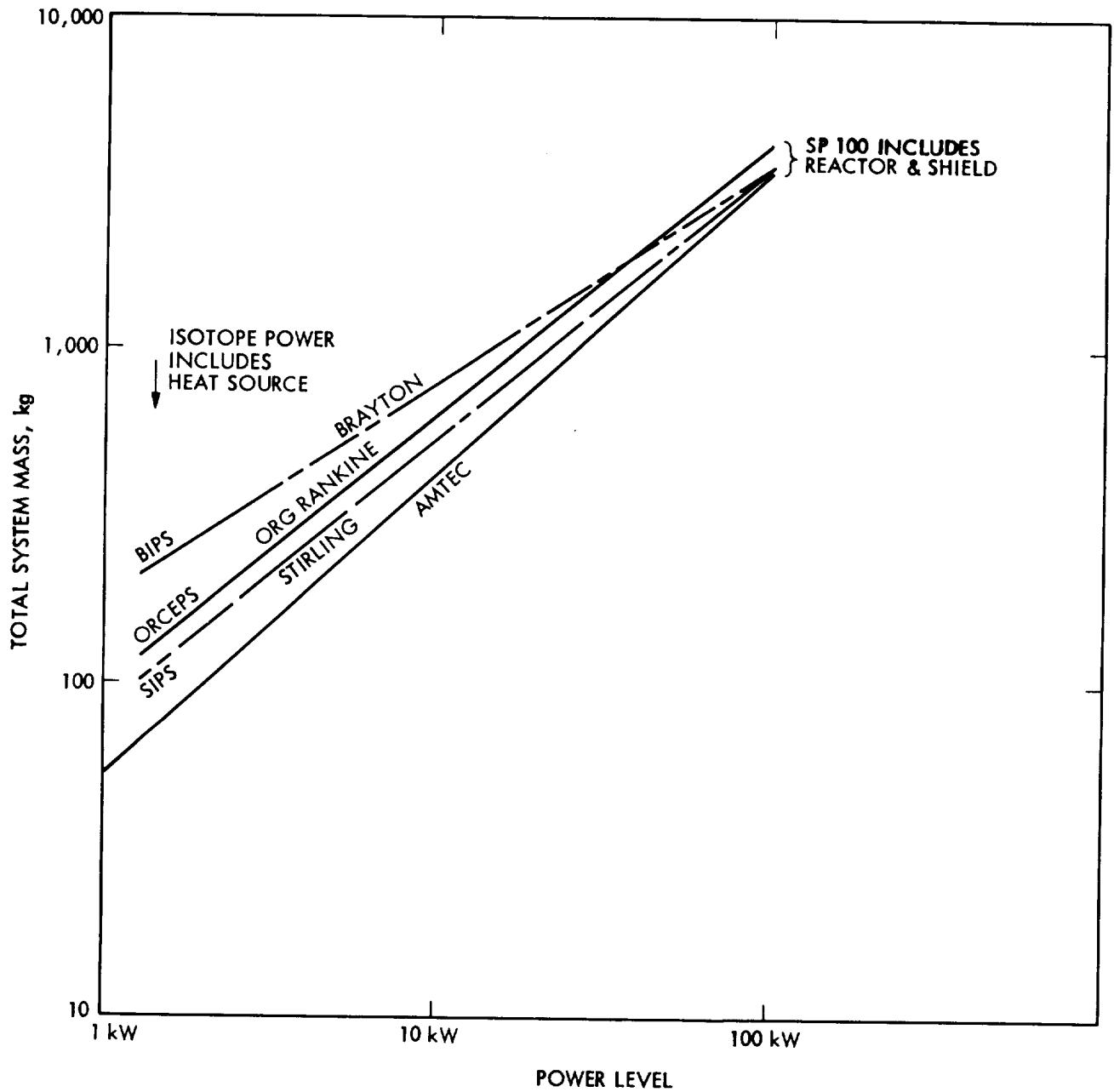

Figure 8. System Mass Comparisons 1-100 kWe

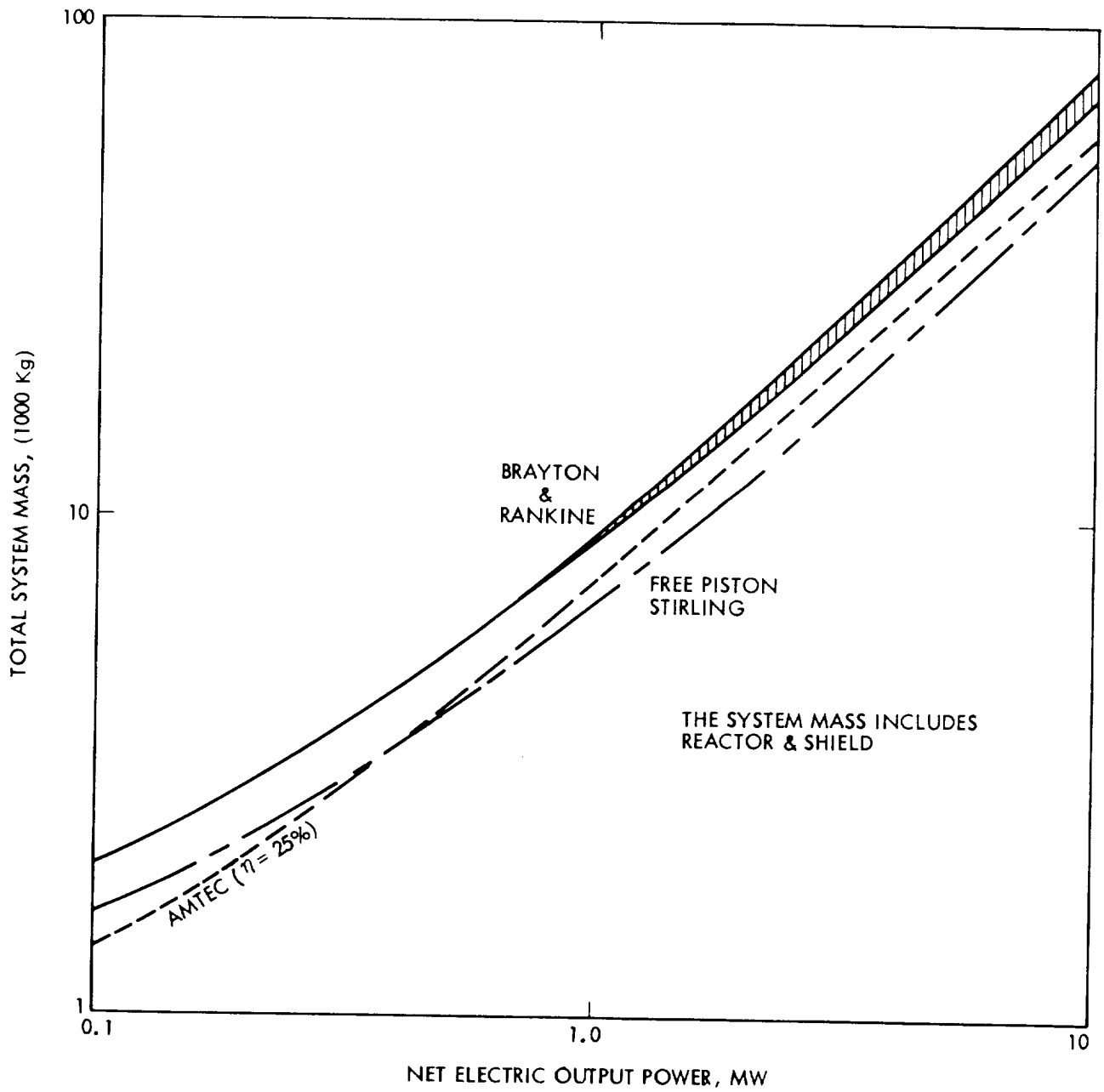

Figure 9. System Mass Comparisons 0.1-10 MW_e

REFERENCES

1. Weber, N., "A Thermoelectric Device Based on Beta-Alumina," *Energy Conversion*, 14, 1 (1974).
2. Cole, T., "Thermoelectric Energy Conversion with Solid Electrolytes," *Science*, 221, 4614, 915 (1983).
3. Kummer, J. T., "B" - Alumina Electrolytes," *Progress in Solid State Chemistry*, 1, edited by J.O. McCaldin, Pergamon Press, New York, 141 (1972).
4. Hunt, T.K., Weber, N. and Cole, T., "Research on the Sodium Heat Engine," *Proceedings of the 13th Intersociety Energy Conversion Engineering Conference*, SAE, Warrendale, PA, 2011 (1978).
5. Hunt, T.K., Weber, N. and Cole, T., "High Efficiency Thermoelectric Conversion with Beta"-Alumina Solid Electrolytes, The Sodium Heat Engine," Fast Ionic Transport in Solids, edited by J.B. Bates and G.C. Farrington, North-Holland Publishing Co., Amsterdam, 263 (1978).
6. Chum, H.L. and Osteryoung, R.W., "Review of Thermally Regenerative Electrochemical Systems," SERI Report TR-332-416, Vols. 1 and 2, April 1982.
7. Bankston, C.P., Cole, T., Jones, R. and Ewell, R., "Experimental and Systems Studies of the Alkali Metal Thermoelectric Converter for Aerospace Power," *J. Energy*, 7, 5, 442 (1983).
8. Hunt, T.K. and Weber, N., Ford Scientific Research Staff, private communication (1985).
9. Bankston, C. P., Cole, T., Khanna, S. K. and Thakoor, A. P., "Alkali Metal Thermoelectric Conversion (AMTEC) for Space Nuclear Power Systems," Space Nuclear Power Systems, 1984, ed. by M. S. El-Genk and M.D. Hoover, Orbit Book Co., Malabar, FL, 393 (1985).
10. Ewell, R., "Energy Conversion for Megawatt Space Power Systems," *Proceedings of the 18th Intersociety Energy Conversion Engineering Conference*, AIChE, New York, 87 (1983).

11. Klein, G. (ed)., "FY'85 Second Quarter Progress Report for Planetary Spacecraft System's Technology Program," JPL Report D-2280, March 1985.
12. Subramanian, K., and Hunt, T.K., "Solar Residential Total Energy System Using the Sodium Heat Engine - A Concept Study," Proceedings of the 17th Intesociety Energy Conversion Engineering Conference," IEEE, New York, 1474, (1982).
13. Subramanian, K., and Hunt, T.K., "Solar Thermal/Electric Power Conversion Using the Sodium Engine," ASME Solar Energy Conference, April 1983.
14. Lukens, Laurance L., "Dish Electric Systems Heat Engine Assessment," Proceedings of the Distributed Receiver Solar Thermal Technology Conference, ed. by J.F. Muir, Sandia Report SAND84-2454, Albuquerque, NM, April 1985, pp. 177-184.
15. Bland, T.J., Niggemann, R. e. and Wren, P.W., "Organic Rankine Cycle Power Conversion Systems for Space Application," IECEC 839162.
16. Macosko, R.P., Barna, C.J., Block, H.B. and Ingle, B.D., "Isotope Brayton Electric Power System for the 500-2500 Watt Range," IECEC 729085.
17. Boretz, J.E., " Radioisotope Dynamic Power System," TRW Applied Technology Division.