

N87-17829

Model Reference Control of Distributed Parameter Systems: Application to the SCOLE Problem

by

H. Kaufman

D. Minnick

M. Balas

A. Musalem

**Rensselaer Polytechnic
Institute**

PRECEDING PAGE BLANK NOT FILMED

MODEL REFERENCE CONTROL
OF DISTRIBUTED PARAMETER SYSTEMS
WITH APPLICATION TO THE SCOLE PROBLEM

BY

H. KAUFMAN

D. MINNICK

M. BALAS

A. MUSALEM

ELECTRICAL, COMPUTER AND SYSTEMS ENGINEERING DEPARTMENT
RENSSELAER POLYTECHNIC INSTITUTE
TROY, NEW YORK 12180-3590

OUTLINE

- INTRODUCTION
- MODEL REFERENCE CONTROL OF LUMPED LINEAR SYSTEMS
THEORY
SCALE APPLICATION
- MODEL REFERENCE CONTROL OF DPS
THEORY
SCALE APPLICATION
- CONCLUSIONS AND RECOMMENDATIONS

INTRODUCTION

SCALE MODELS

LUMPED: 16th ORDER WITH 5 FLEXIBLE AND 3 RIGID BODY MODES

DISTRIBUTED: 3 PARTIAL DIFFERENTIAL EQUATIONS FOR ROLL,
PITCH, YAW BEAM BENDING

LUMPED MODEL

$$\dot{x} = Ax + Bu$$

$$y = Cx$$

$$x^T = (\underline{u}_1^T, \dots, \underline{u}_8^T, \underline{\phi}_{RB}^T, \underline{\theta}_{RB}^T, \underline{\psi}_{RB}^T)$$

$$y_F^T = (\underline{\phi}_S^T, \underline{\theta}_S^T, \underline{\psi}_S^T, \underline{\phi}_r^T, \underline{\theta}_r^T, \underline{\psi}_r^T, \underline{\zeta}_x, \underline{\zeta}_y)$$

$$y^T = y_F^T + (\underline{\phi}_{RB}^T, \underline{\theta}_{RB}^T, \underline{\psi}_{RB}^T, \underline{\phi}_{RB}^T, \underline{\theta}_{RB}^T, \underline{\psi}_{RB}^T, 0, 0)$$

$$\underline{u}^T = (\underline{I}_S, \underline{f}_r, \underline{I}_r)$$

OBJECTIVE: IF $\phi_{RB}(0) = 20^\circ$

$\phi_{RB} \rightarrow 0$ IN ABOUT 10 SEC.

$$|T| \leq 10,000$$

$$|f| \leq 800$$

DISTRIBUTED MODEL

ROLL BEAM BENDING:

$$PA \frac{\partial^2 u_\phi}{\partial t^2} + 2\zeta_\phi \sqrt{PA EI_\phi} \frac{\partial^3 u_\phi}{\partial s^2 \partial t} + EI_\phi \frac{\partial^4 u_\phi}{\partial s^4} = \sum_{n=1}^4 [f_{\phi,n} \delta(s-s_n) + g_{\phi,n} \frac{\partial \delta}{\partial s}(s-s_n)]$$

PITCH BEAM BENDING:

$$PA \frac{\partial^2 u_\theta}{\partial t^2} + 2\zeta_\theta \sqrt{PA EI_\theta} \frac{\partial^3 u_\theta}{\partial s^2 \partial t} + EI_\theta \frac{\partial^4 u_\theta}{\partial s^4} = \sum_{n=1}^4 [f_{\theta,n} \delta(s-s_n) + g_{\theta,n} \frac{\partial \delta}{\partial s}(s-s_n)]$$

YAW BEAM TORSION:

$$PI_\psi \frac{\partial^2 u_\psi}{\partial t^2} + 2\zeta_\psi I_\psi \sqrt{GP} \frac{\partial^3 u_\psi}{\partial s^2 \partial t} + GI_\psi \frac{\partial^2 u_\psi}{\partial s^2} = \sum_{n=1}^4 g_{\psi,n} \delta(s-s_n)$$

MODEL REFERENCE CONTROL OF LUMPED LINEAR SYSTEMS

THEORY

$$\left. \begin{aligned} \dot{x}_p &= A_p x_p + B_p u_p \\ y_p &= C_p x_p \end{aligned} \right\} \text{PROCESS}$$

$$\left. \begin{aligned} \dot{x}_m &= A_m x_m + B_m u_m \\ y_m &= C_m x_m \end{aligned} \right\} \text{REFERENCE MODEL}$$

DESIRE

$$y_p \rightarrow y_m$$

DEFINE IDEAL STATE AND CONTROL

$$\dot{x}_p^* = A_p x_p^* + B_p u_p^*$$

$$y_p^* = C_p x_p^*$$

WHERE $y_p^* = C_m x_m = y_m$

WILL FORCE $x_p \rightarrow x_p^*$

$$\implies y_p \rightarrow y_p^* = y_m$$

ASSUME

$$x_p^* = S_{11} x_M + S_{12} u_M$$

$$u_p^* = S_{21} x_M + S_{22} u_M$$

THEN

$$S_{11} A_M - A_P S_{11} = B_P S_{21}$$

$$S_{11} B_M - A_P S_{12} = B_P S_{22}$$

$$C_P S_{11} = C_M$$

$$C_P S_{12} = 0$$

APPLY

$$u_p = u_p^* + K(y_m - y_p)$$

THEN

$$\dot{e} = (A_p - B_p K C_p)e$$

WHERE

$$e = x_p^* - x_p$$

∴ CHOOSE K TO STABILIZE $(A_p - B_p K C_p)$

Figure 1: System block diagram.

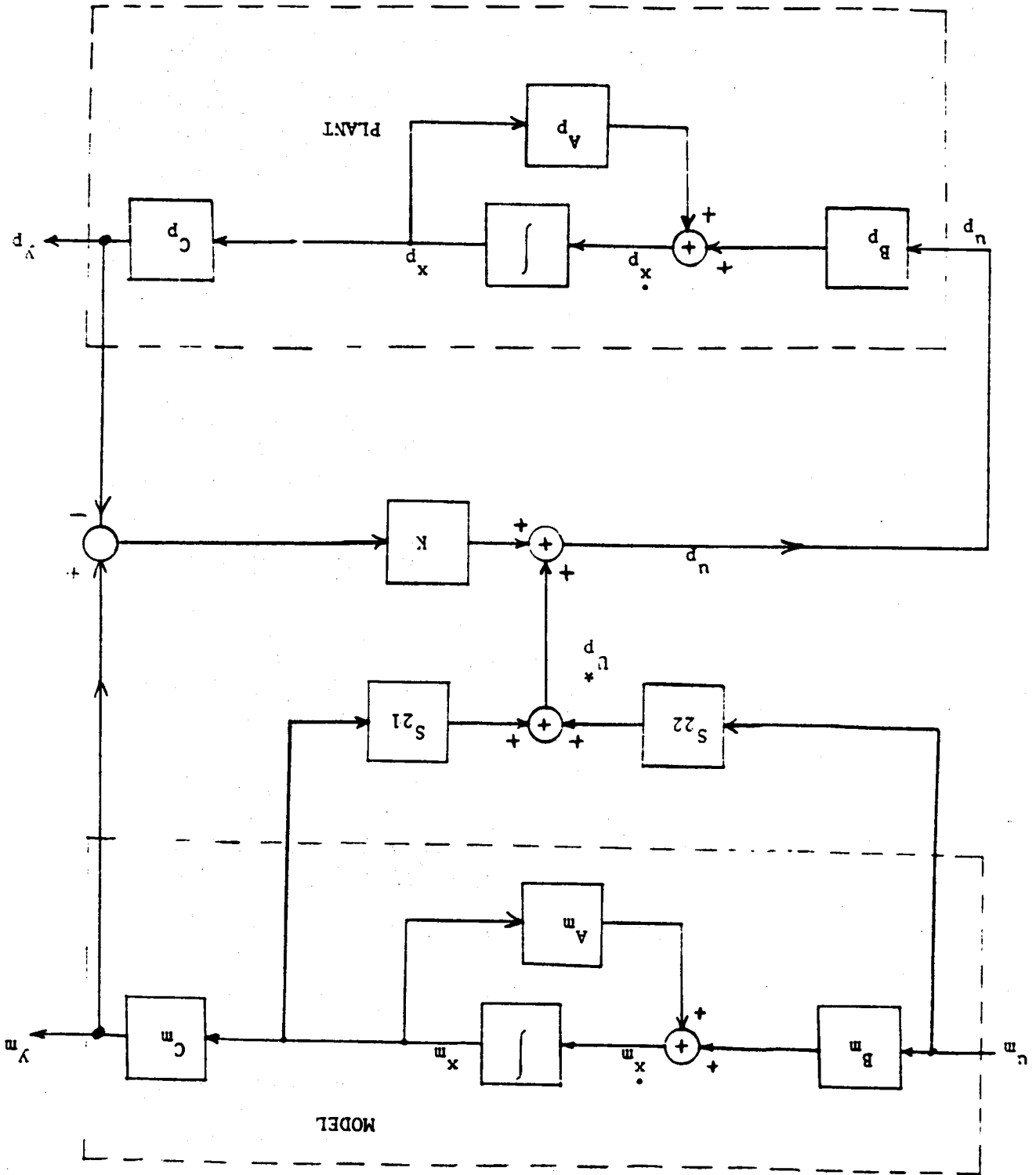

SPECIAL CASE (PMF)

$$x_p \rightarrow x_m$$

OR $C_p = C_m = I$

$$u_p = S_{21} x_m + S_{22} u_m + K(x_m - x_p)$$

$$B_p S_{21} = A_m - A_p$$

$$B_m = B_p S_{22}$$

$(A_p - B_p K)$ STABLE

SCALE APPLICATION OF LUMPED MODEL FOLLOWING

OBSERVATIONS

- EIGHT CONTROLS
- EIGHT OUTPUT MODES TO BE CONTROLLED

PROCEDURES

- PMF
- $x_p \rightarrow x_m$
- OUTPUT FOLLOWING
- $y_p \rightarrow y_m$

SPECIAL CASES: 8 outputs

CASE I: Consider only positions:

$$Y_P^T = [\theta_S + \theta_{RB}, \theta_S + \theta_{RB}, \psi_S + \psi_{RB}, \xi_X, \xi_Y, \theta_r + \theta_{RB}, \psi_r + \psi_{RB}]^T$$

CASE II: Position and LOS vectors

$$Y_P^T = [\theta_S + \theta_{RB}, \theta_S + \theta_{RB}, \psi_S + \psi_{RB}, \xi_X, \xi_Y, E_1, E_2, E_3]^T$$

E_1, E_2, E_3 - LOS VECTOR COMPONENTS

Note: $R_{LOS} = (R_{LOS})_{NOM} + \Delta$, where $\Delta = \begin{bmatrix} E_1 \\ E_2 \\ E_3 \end{bmatrix}$

$$E_1 = -130 \theta_{RB} - 32.2 \psi_{RB} + \xi_X - 32.2 \psi_r - 260 \theta_r$$

$$E_2 = 130 \theta_{RB} + 18.75 \psi_{RB} + \xi_Y + 18.75 \psi_r - 260 \theta_r$$

$$E_3 = -18.75 \theta_{RB} + 32.2 \theta_{RB} - 18.75 \theta_r - 32.2 \theta_r$$

INITIAL CONDITIONS

Two sets of I.C.'s for each case

CASE I (a):

Choose θ_{RBI} , θ_{RBF} , θ_{RBI} , θ_{RBF} so that $e_{LOS}(0) = 20^\circ$, $e_{LOS}(t_f) = 0^\circ$

$\Rightarrow \theta_{RBI} = 0.1063$ rad ; $\theta_{RBF} = -0.245$ rad

$\theta_{RBI} = -0.1115$ rad ; $\theta_{RBF} = -0.1115$

$t_f = 10$ sec.

$\Rightarrow Y_0^T = [0.0163, -0.1115, 0, 0, 0, 0.1063, -0.1115, 0]^T$

STATE I.C.'s:

$Y_p(0) = C_p X_p(0)$ ----- Solve for $X_p(0)$

Model I.C.'s

$Y_p \rightarrow Y_m, Y_p(0) = Y_m(0)$

$\Rightarrow X_m^T = [0.1063, -0.1115, 0, 0]^T$

COMMAND

II (0) = 1.0, T > 0. i = 1, 2, ..., 8

I.C.'s (cont.)

CASE I (b):

$$\theta_{RB} = 0.34 \text{ rad} = 20^\circ$$

$$\psi_{RB} = \theta_{RB} = 0.0$$

$$\Rightarrow Y_p^T(0) = [0.34, 0, 0, 0, 0, 0, 0, 0, 0, 0, 0]^T$$

Model:

$$X_m^T = [0.34, 0, 0, 0, 0]^T$$

COMMAND:

$$U_{m_i}(0) = 0.0, \quad T \geq 0, \quad i = 1, \dots, 8$$

I. C."s (cont.)

CASE II (a): Same objective as in CASE I (a)

$$Y_P^T(o) = \{0.1063, -0.1115, 0, 0, 0, 14.49, 13.82, 5.51\}^T$$

$$X_M^T(o) = \{0.1063, -0.1115, 0, 0, 1\}$$

$$\Rightarrow Y_M(o) = Y_P(o)$$

$$U_{m_j} = 1.0, \quad j = 1, \dots, 8$$

CASE II(b): Same objective as in CASE I (b)

$$Y_P^T(o) = \{0.34, 0, 0, 0, 0, 44.2, 10.948\}^T$$

$$X_M^T = \{0.34, 0, 0, 0, 1\}^T$$

MODEL

In both cases: 4 states

$$\dot{X}_M = A_m X_M + B_M U_M$$

$$A_M = \text{DIAG } [A_1 \ A_2 \ A_3 \ A_4] = [-.15, -0.10, -0.10, -0.10]^T$$

$$Y_M^T = [Y_{M1} \ Y_{M2} \ \dots \ Y_{M8}]^T$$

CASE I (a, b):

$$C_M = \begin{bmatrix} 1 & 0 & 0 & 0 \\ 0 & 1 & 0 & 0 \\ 0 & 0 & 1 & 0 \\ 0 & 0 & 0 & 1 \\ 1 & 0 & 0 & 1 \\ 0 & 1 & 0 & 0 \\ 0 & 0 & 1 & 0 \end{bmatrix}$$

CASE II (a, b):

$$C_M = \begin{bmatrix} 1 & 0 & 0 & 0 \\ 0 & 1 & 0 & 0 \\ 0 & 0 & 1 & 0 \\ 0 & 0 & 0 & 1 \\ 0 & 0 & 0 & 1 \\ 0 & -130 & 0 & 0 \\ 130 & 0 & 0 & 0 \\ 32.2 & -18.75 & 0 & 0 \end{bmatrix}$$

MODEL (cont.)

Matrix BM:

Cases I (a), II (a):

$$B_M = \begin{bmatrix} -3.67 \times 10^{-2} & 0 & 0 & 0 & 0 & 0 & 0 & 0 & 0 \\ 0 & -1.115 \times 10^{-2} & 0 & 0 & 0 & 0 & 0 & 0 & 0 \\ 0 & 0 & 0 & 0 & 0 & 0 & 0 & 0 & 0 \\ 0 & 0 & 0 & 0 & 0 & 0 & 0 & 0 & 0 \end{bmatrix}$$

Cases II (b), II (b):

$$B_M = [0]$$

SYSTEM I.C.'s: RESULTS

CASE I (a):

$$Y_P^T(o) = Y_M^T(o) = [0.1063 \quad -0.1115, \quad 0, \quad 0, \quad 0, \quad 0.1063, \quad -0.1115, \quad 0]^T$$

$$X_P^T(o) = [0, \quad 0, \quad 0, \quad 0, \quad 0, \quad 0, \quad 0, \quad 0.1063, \quad 0, \quad -0.1115, \quad 0, \quad 0, \quad 0]^T$$

$$X_P^{*T}(o) = [0, \quad 0, \quad 0, \quad 0, \quad 0, \quad 0, \quad 0, \quad 0.1063, \quad -0.05269, \quad -0.1115, \quad 0, \quad 0, \quad 0]^T$$

CASE I (b):

$$Y_P^T(o) = Y_M^T(o) = [0.34, \quad 0, \quad 0, \quad 0, \quad 0, \quad 0.34, \quad 0, \quad 0]^T$$

$$X_P^T(o) = [0, \quad 0, \quad 0, \quad 0, \quad 0, \quad 0, \quad 0, \quad 0.34, \quad 0, \quad 0, \quad 0, \quad 0, \quad 0]^T$$

$$X_P^{*T}(o) = [0, \quad 0, \quad 0, \quad 0, \quad 0, \quad 0, \quad 0, \quad 0.34, \quad -0.051, \quad 0, \quad 0, \quad 0, \quad 0]^T$$

LOS ERROR : CASE II(a)

$$e_{LOS} = \sin^{-1} \left[\frac{\| \delta_T \times T_i \bar{R}_{LOS} \|}{\| R_{LOS} \|} \right]$$

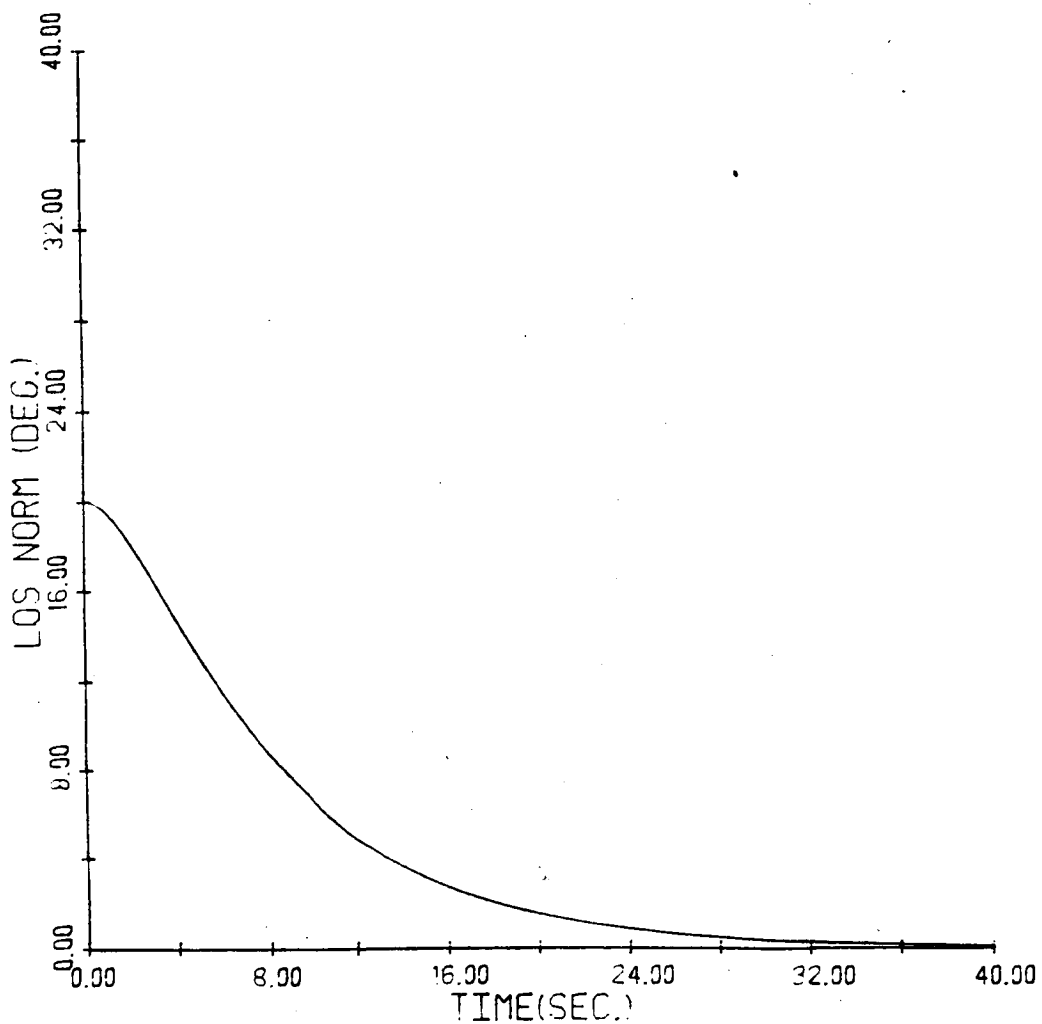

OUTPUT: PLANT and Model
Case II (a)

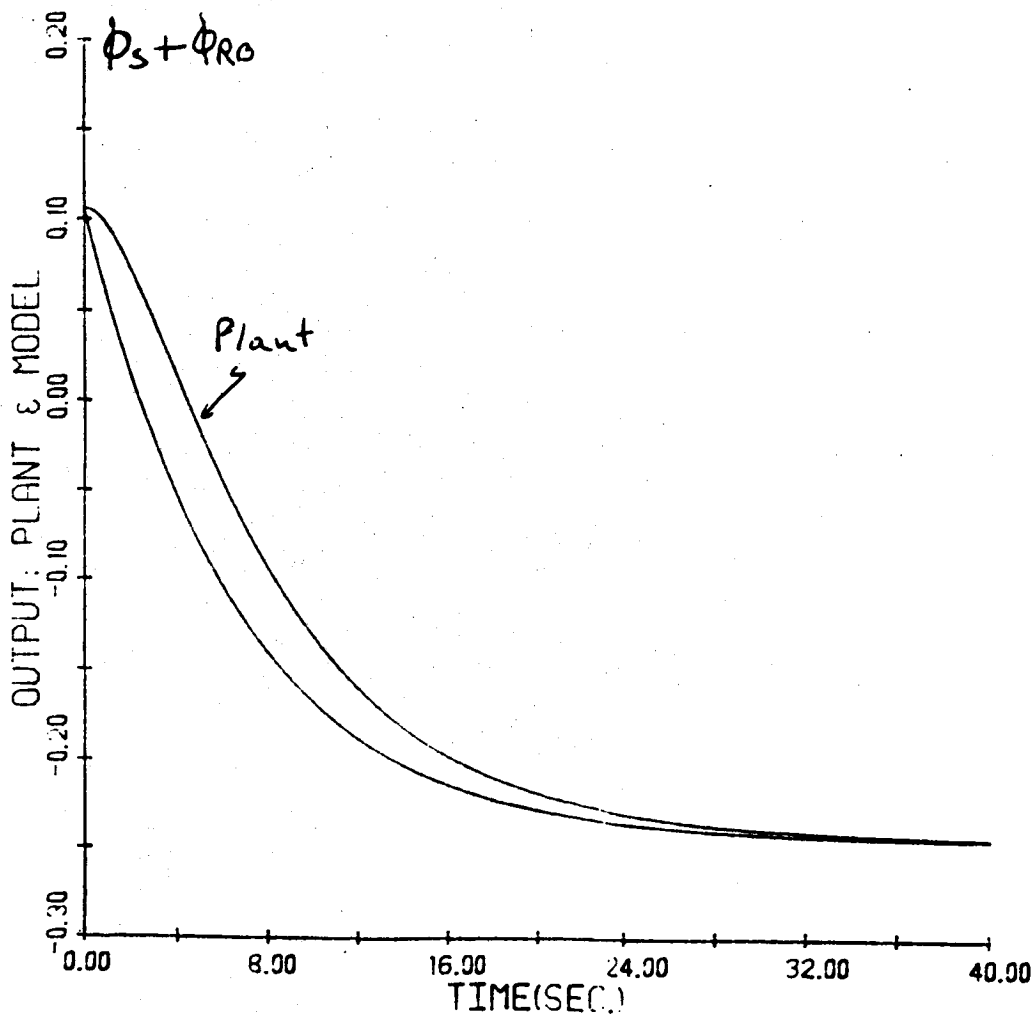

OUTPUT: PLANT and Model
Case II (a)

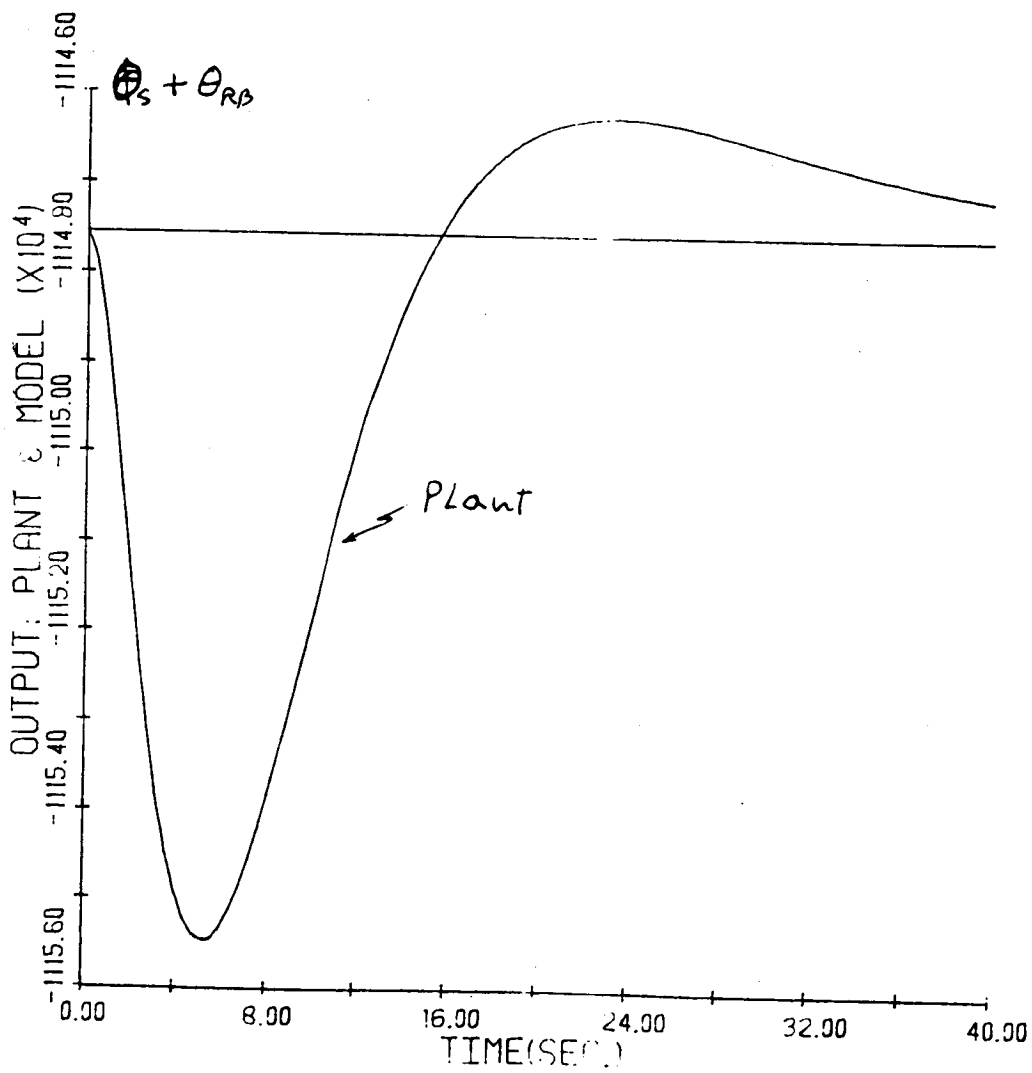

OUTPUT: PLANT and Model
CASE II(a): 1st Component of LOS

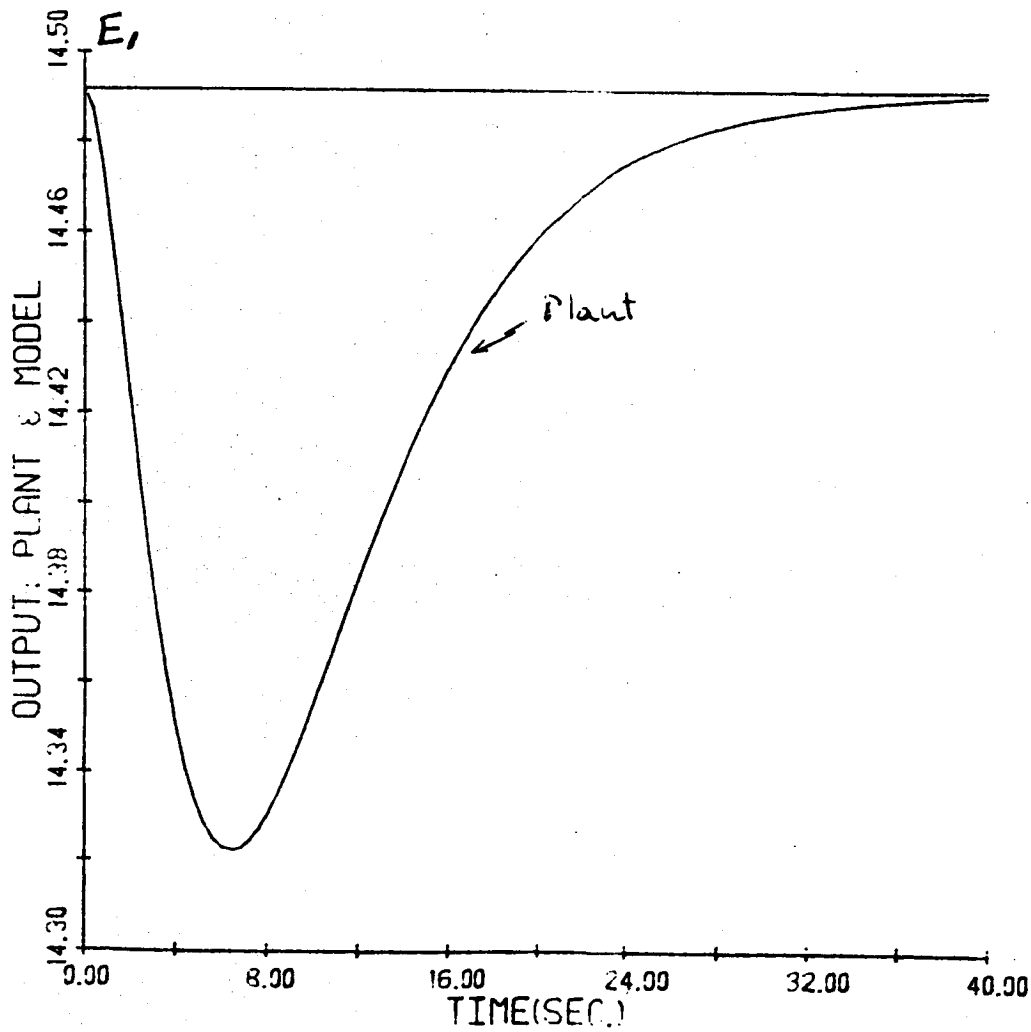

C-3

OUTPUT: PLANT and Model
CASE II(a): 2nd Component of LOS

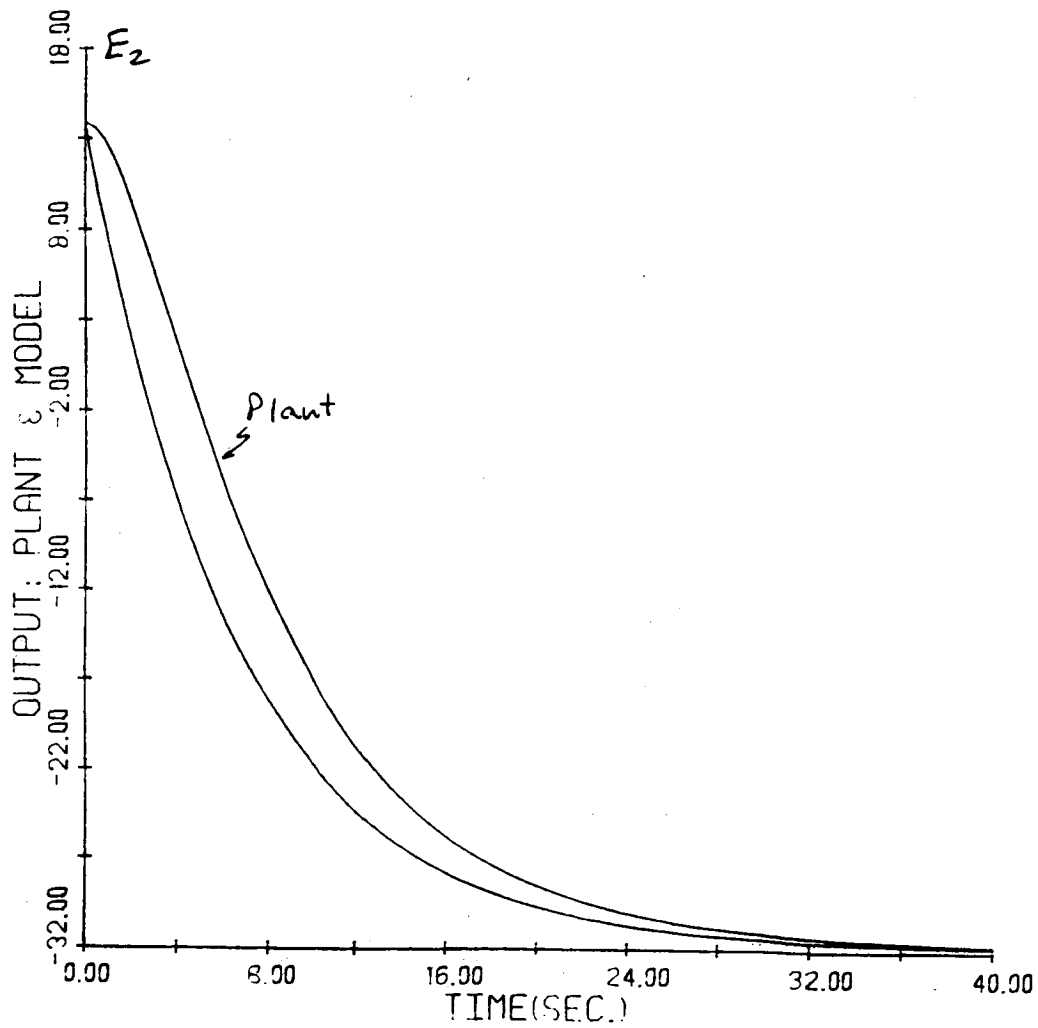

OUTPUT : PLANT and Model
CASE II(a) : 3RD Component of LOS

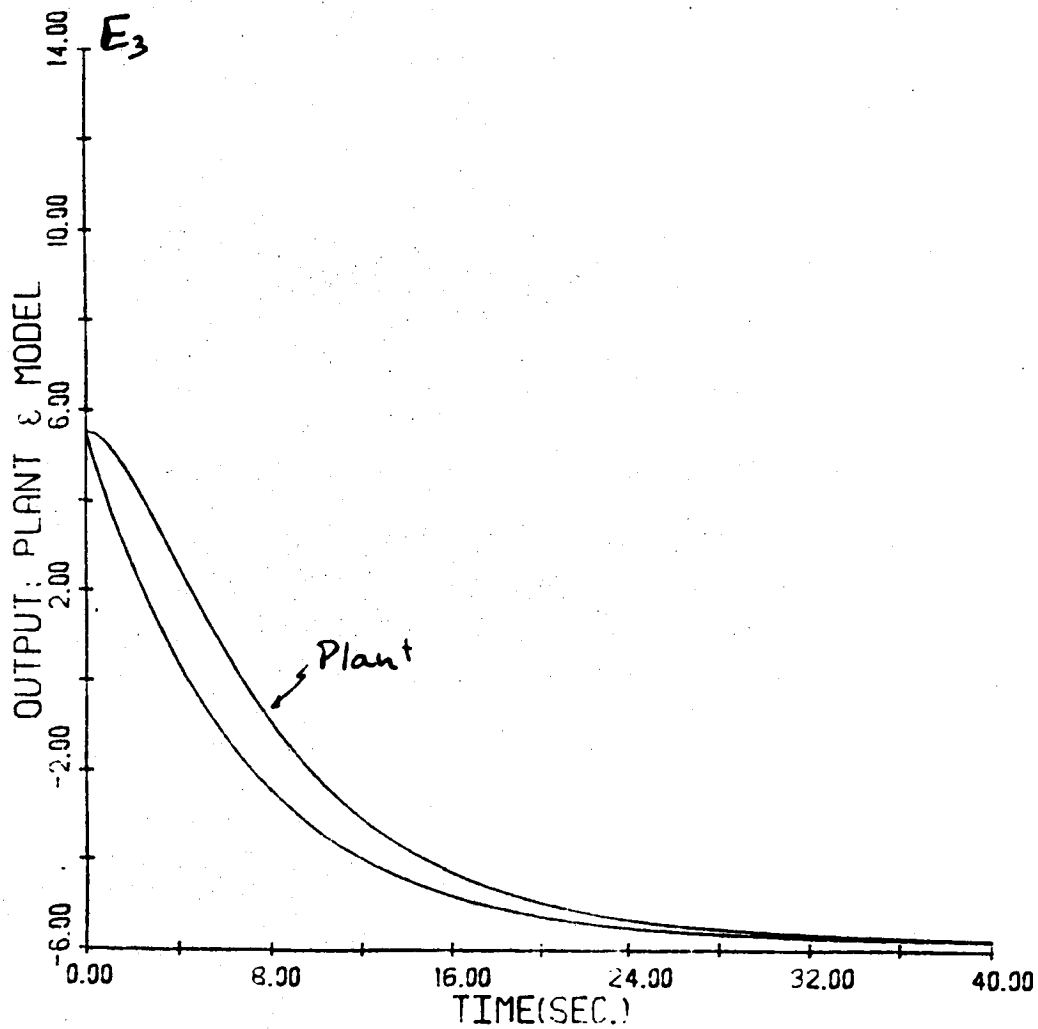

CONTROL : CASA II(a)

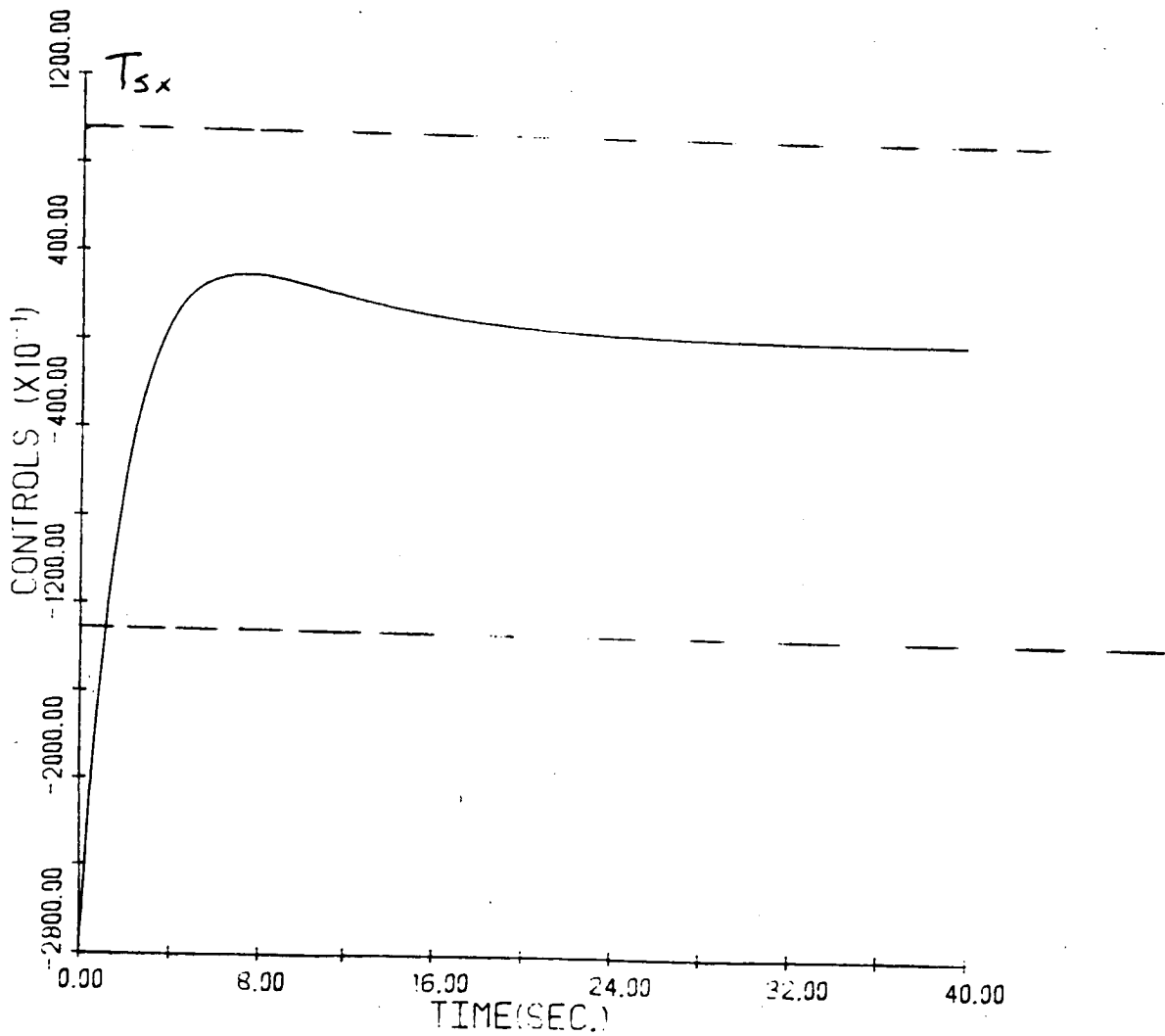

CONTROL : CONTROL : CASE II(a)

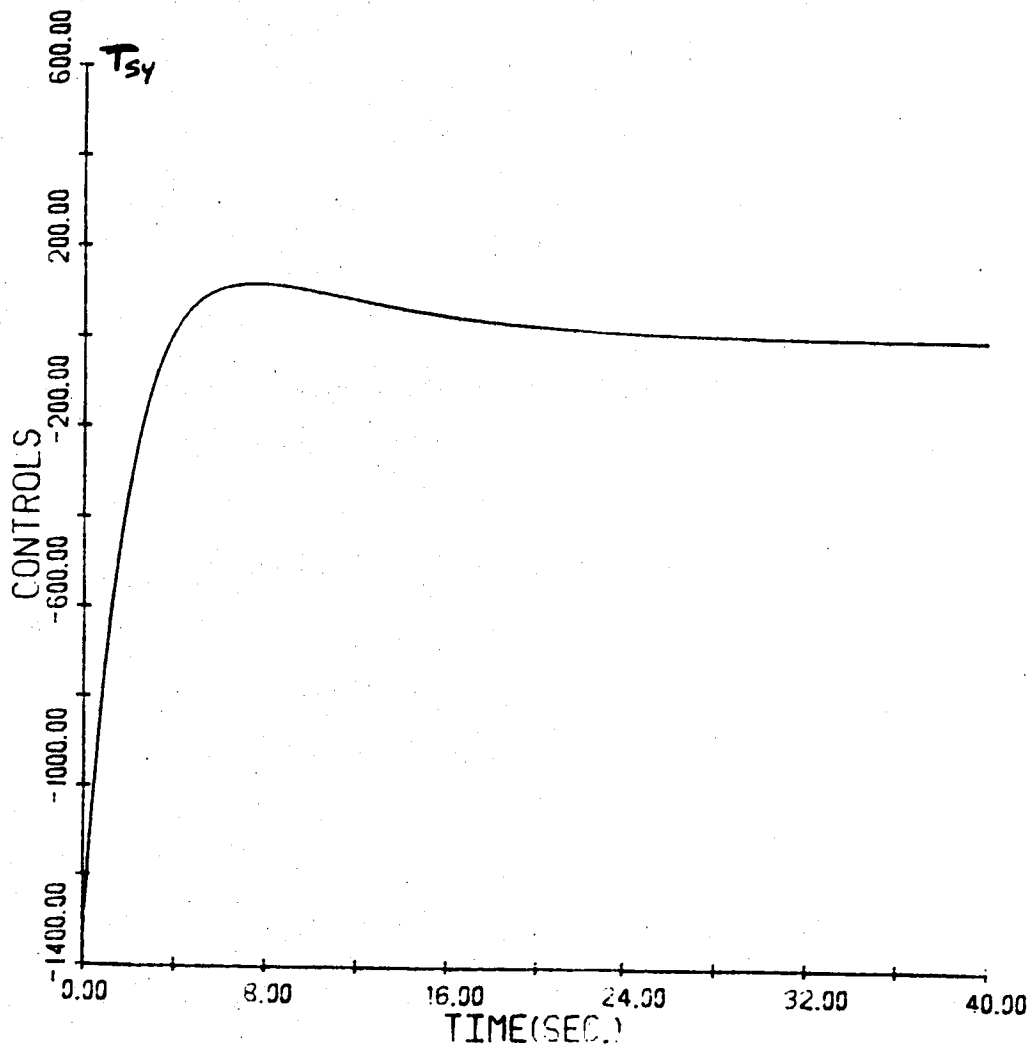

CONTROL: CASE II (a)

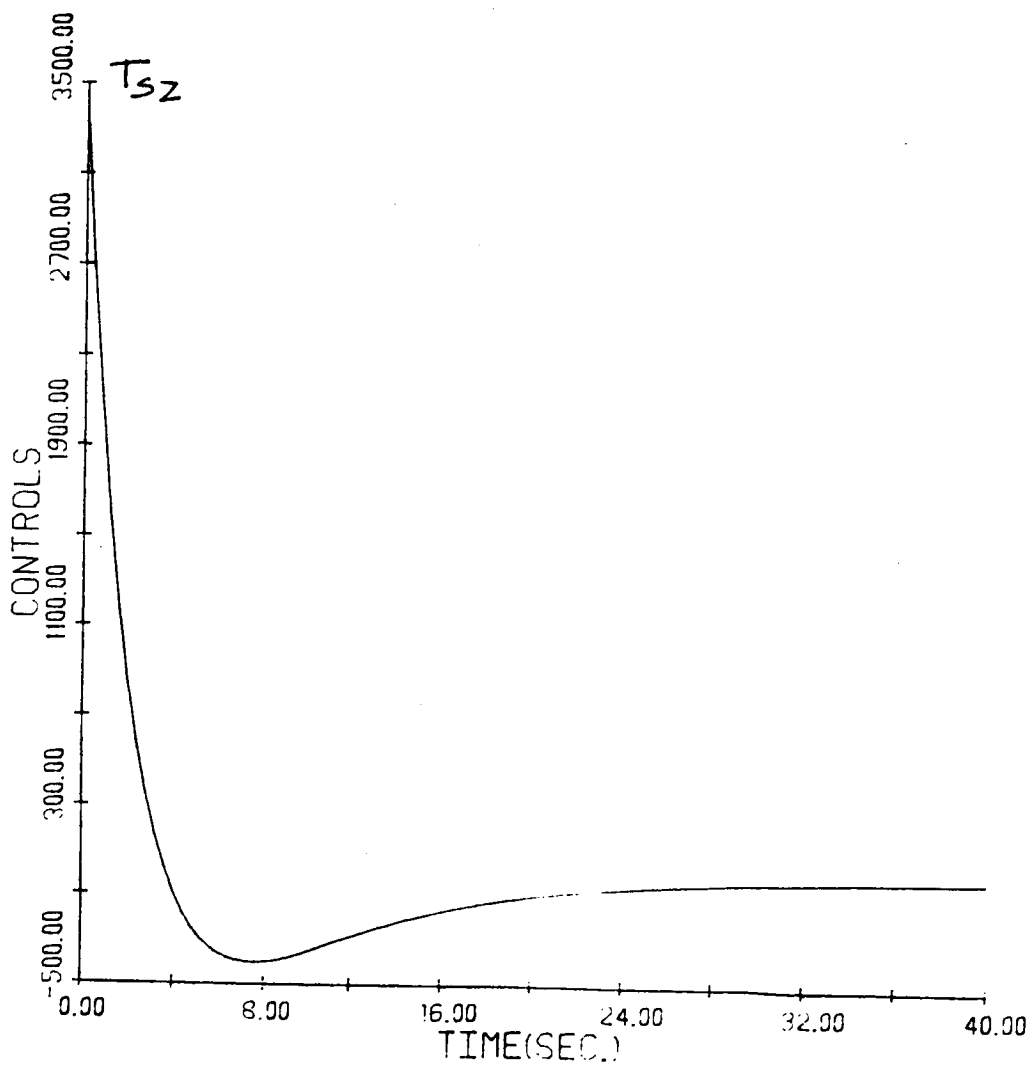

NORM OF MOMENTS AT SHUTTLE : CASE II (a)

$$= (T_{sx}^2 + T_{sy}^2 + T_{sz}^2)^{1/2}$$

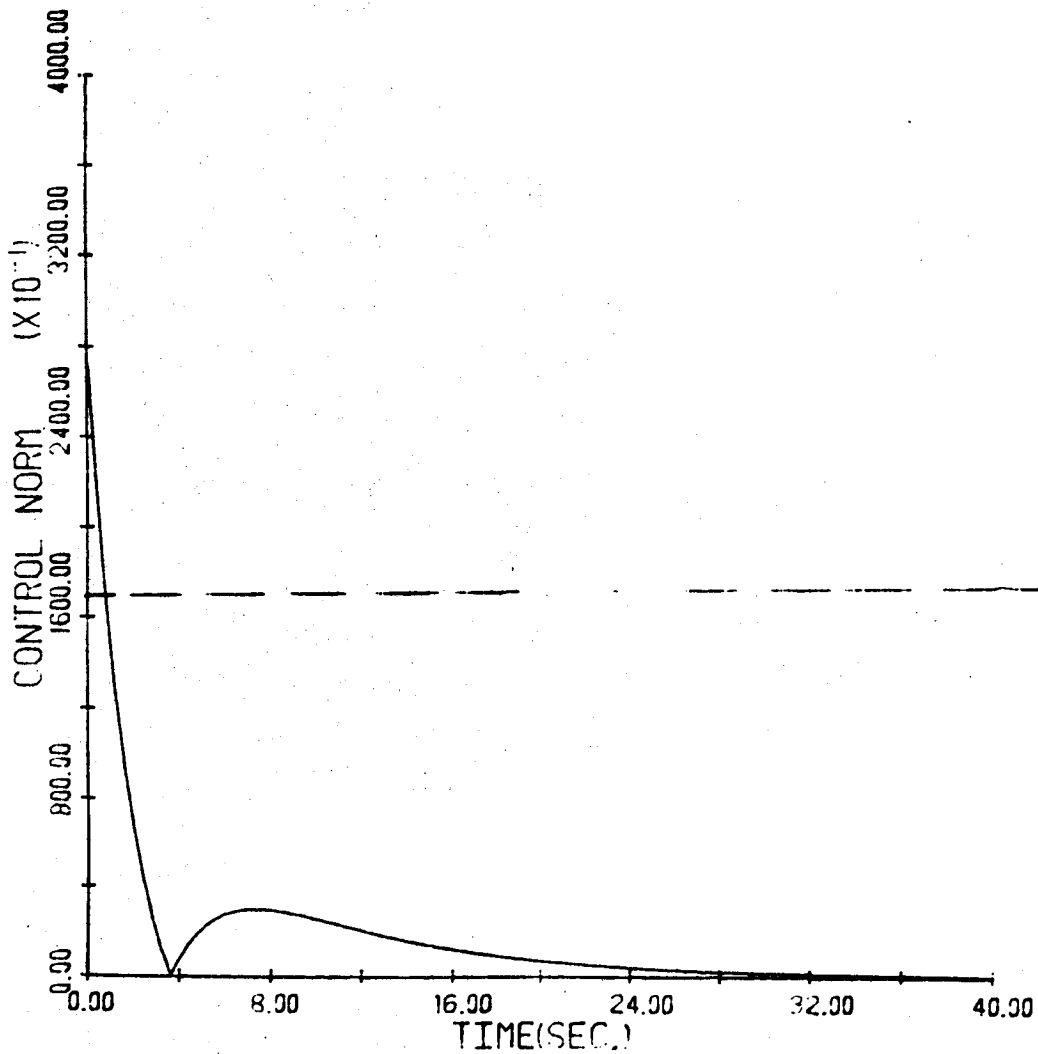

NORM of FORCES AT REFLECTOR : CASE II (a)

$$= (f_{nx}^2 + f_{ny}^2)^{1/2}$$

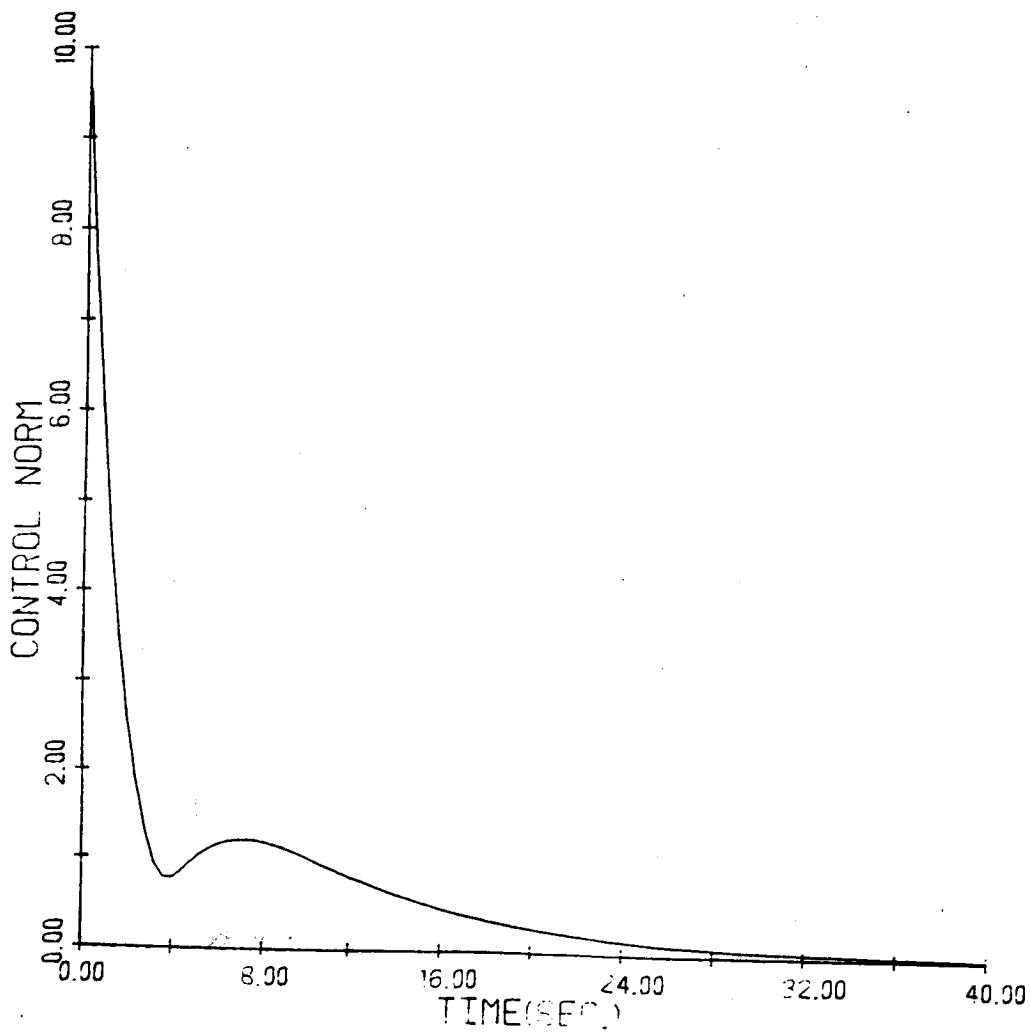

NORM OF MOMENTS AT REFLECTOR: CASE II (a)

$$= (T_{ax}^2 + T_{ay}^2 + T_{az}^2)^{1/2}$$

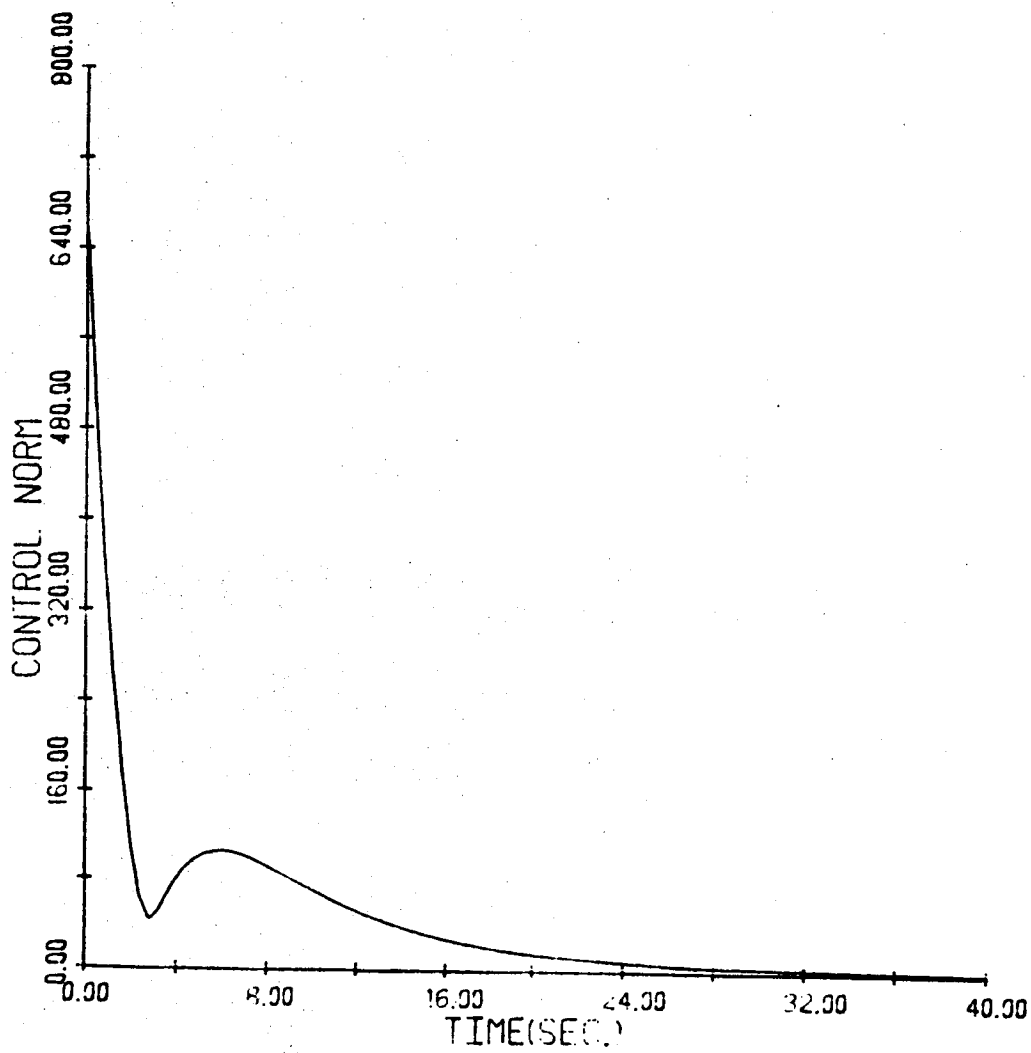

PLANT STATE : CASE II (a)

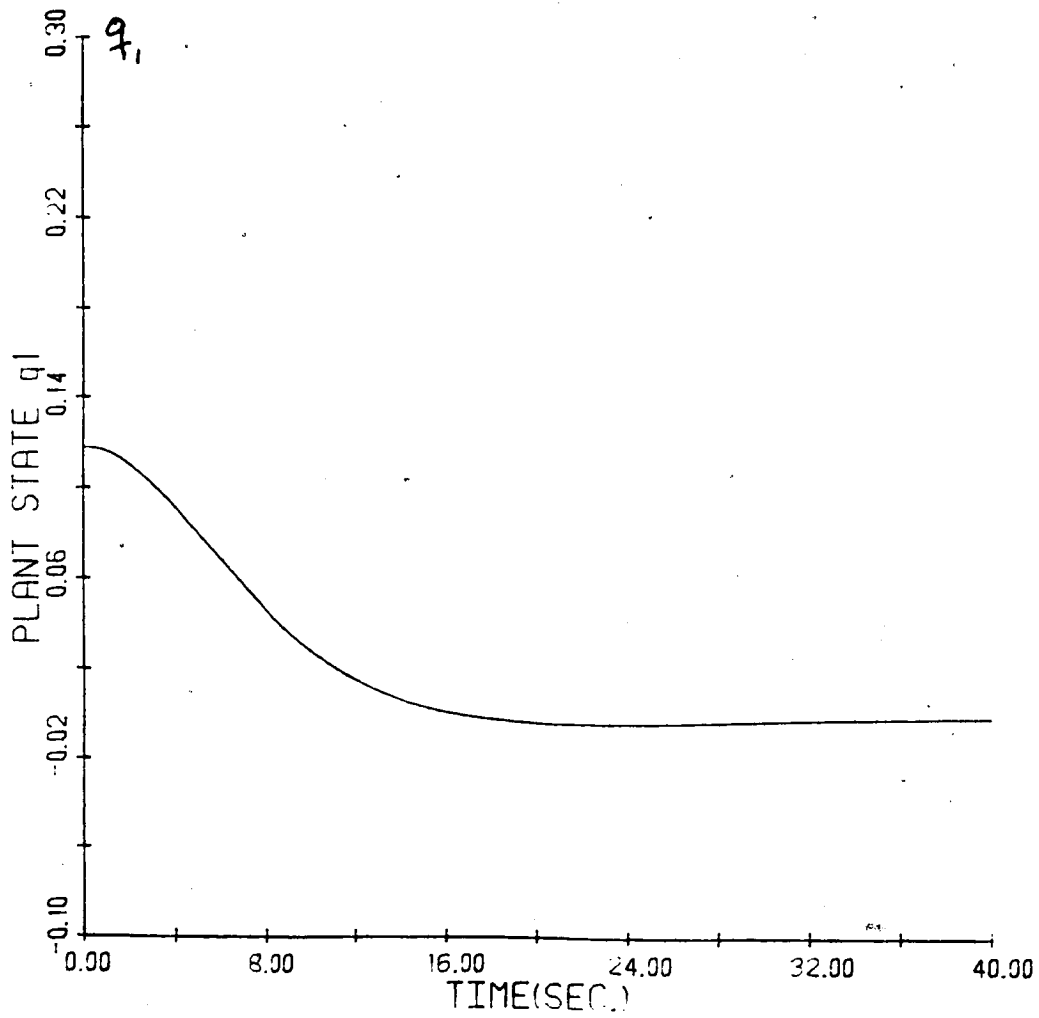

MODEL REFERENCE CONTROL OF DISTRIBUTED SYSTEMS

$$m(x)u_{tt}(x,t) + D_0 u_t(x,t) + A_0 u(x,t) = f(x,t)$$

$$v_1 = u(x,t)$$

$$\text{BC } v_1''(0) = v_1''(L) = 0$$

$$v_2 = \frac{\partial}{\partial t} u(x,t)$$

$$\text{and } v_2''(0) = v_2''(L) = 0$$

$$\dot{\underline{v}} = \underline{A}\underline{v} + \underline{B} f(x,t)$$

$$\underline{A} = \begin{bmatrix} 0 & 1 \\ -\frac{A_0}{m(x)} & -\frac{D_0}{m(x)} \end{bmatrix}$$

$$\underline{B} = \begin{bmatrix} 0 \\ \frac{1}{m(x)} \end{bmatrix}$$

$$y = Cv$$

CONTROL PROBLEM FORMULATION

GIVEN THE DPS, IT IS DESIRED TO FIND A FINITE DIMENSIONAL CONTROLLER

SO THAT THE OUTPUT $y(t)$ "FOLLOWS" A DESIRABLE OUTPUT TRAJECTORY $y_m(t)$.

$$\dot{q} = A_m q + B_m u_m$$

$$y_m = C_m q$$

SOLUTION TO DPS MRC PROBLEM

DEFINE IDEAL STATE AND CONTROL v^* , f^*

$$\frac{\partial v^*(t)}{\partial t} = A v^*(t) + B f^*(t)$$

$$y^*(t) = C v^*(t)$$

$$y^*(t) = y_m(t) = C_m q(t)$$

$$v^*(t) = S_{11}(x) q(t) + S_{12}(x) u_m(t)$$

$$f^*(t) = S_{21} q(t) + S_{22} u_m(t)$$

$$y^*(t) = C S_{11} q + C S_{12} u_m = y_m = C_m q$$

$$S_{11}(x) A_m = A S_{11}(x) + B S_{21}$$

$$S_{11} B_m = A S_{12}(x) + B S_{22}$$

$$C S_{11} = C_m$$

$$C S_{12} = 0$$

$$\dot{e} = \dot{v}^* - \dot{v} =$$

$$A v^* + B f^* - A v - B f =$$

$$A e + B (f^* - f)$$

THIS EQUATION SUGGESTS THAT THE ACTUAL MODEL FOLLOWING

CONTROL (f) BE DEFINED AS:

$$f = f^* + G(y_m - y)$$

$$= f^* + G(C q_m - C v)$$

$$= f^* + G C (v^* - v)$$

$$= f^* + G C e$$

SUBSTITUTION OF (3.14) INTO (3.13) GIVES:

$$\dot{e} = (A - B G C)e$$

FOR ILLUSTRATIVE PURPOSES WE WILL CONTROL

$$\omega_4 = \dot{v}'(t, L) = y_1$$

$$\omega_1 = \dot{v}'(t, 0) = y_2$$

AND

$$y_3 = v(t, s_0) + \alpha \dot{v}(t, s_0)$$

WHERE

$$0 < s_0 < L$$

THUS

$$C = \begin{bmatrix} 0 & \partial/\partial s[\delta(s-L)] \\ 0 & \frac{\partial}{\partial s} \delta(s) \\ \delta(s-s_0) & \alpha \delta(s-s_0) \end{bmatrix}$$

REFERENCE MODEL

$$\dot{q} = a_m q + b_m u_m$$

$$y_{m1} = c_1 q$$

$$y_{m2} = c_2 q$$

$$y_{m3} = c_3 q$$

UNDER THE ASSUMPTION THAT $u_m = 0$,

$$v_1^* = S_{11}^{-1}(s) q(t)$$

$$v_2^* = S_{11}^{-2}(s) q(t)$$

$$f_1^* = S_{21}^{-1} q$$

$$f_2^* = S_{21}^{-2} q$$

$$f_3^* = S_{21}^{-3} q$$

ILLUSTRATIVE APPLICATION TO SCOLE

ROLL BEAM BENDING EQUATION

ASSUMPTIONS: PROOF MASSES AND DAMPING NEGLIGIBLE, REFLECTION MASS NEGLIGIBLE

$$PA \ddot{v}(t,s) + EI v''''(t,s) = f_1 \delta(s-l) + f_2 \delta'(s) + f_3 \delta'(s-l)$$

$$f_1 = F_y$$

$$f_2 = M_l$$

$$f_3 = M_y$$

CASE 1: (ignore shuttle mass)

$$v''(t,0) = v''(t,L) = 0$$

$$v''''(t,0) = v''''(t,L) = 0$$

CASE 2: Simple-free (shuttle mass \rightarrow infinity)

$$v(t,0) = 0 \quad v'(0,t) = 0$$

$$v''(t,L) = 0 \quad v''''(t,L) = 0$$

CASE I Free-Free

$$\begin{aligned}
 S_{11}^1(s) = & \\
 & + S_{21}^1 \sum \frac{X_K(L)}{K} \frac{L}{4} \frac{X_K'(s)}{(PA a_m^2 + EIK^4) X_K^2(L)} \\
 & + S_{21}^2 \sum \frac{-X_K'(0)}{K} \frac{L}{4} \frac{X_K'(s)}{(PA a_m^2 + EIK^4) X_K^2(L)} \\
 & + S_{21}^3 \sum \frac{-X_K'(L)}{K} \frac{L}{4} \frac{X_K'(s)}{(PA a_m^2 + EIK^4) X_K^2(L)}
 \end{aligned}$$

WHERE

$$\begin{aligned}
 X_K(s) = & \left[\left(\frac{\text{Sinh}(KL) - \text{Sin}(KL)}{\text{Cos}(KL) - \text{Cosh}(KL)} (\text{Cosh } Ks + \text{Cos } Ks) \right) \right. \\
 & \left. + \text{Sinh}(Ks) + \text{Sin}(Ks) \right]
 \end{aligned}$$

SOLVING THE EQUATIONS OF MOTION

$$v(t,s) = \sum_{n=1}^{\infty} Q_n(s) y_n(t)$$

$$EI \frac{d^4 Q_n(s)}{ds^4} - W_n^2 P A Q_n(s) = 0 \quad n = 1, 2, \dots, \infty$$

$$Q_n(s) = A \sin k_n s + B \cos k_n s + C \sinh k_n s + D \cosh k_n s$$

CASE 1

$$Q_n(s) = \left[\frac{\sinh k_n L - \sin k_n L}{\cos k_n L - \cosh k_n L} \right] (\cosh k_n s + \cos k_n s) + \sin k_n s + \sinh k_n s$$

CASE

$$Q_n(s) = \frac{1}{N_n} \left[\frac{\sin k_n L + \sinh k_n L}{\cos k_n L + \cosh k_n L} \right] (\cos k_n s - \cosh k_n s) + \sin k_n s + \sinh k_n s$$

CGT GAIN SOLUTION

Output matrix values

$$\text{Note: } S_{11}(0) = \frac{C_1}{A_m}$$

$$S_{11}(L) = \frac{C_2}{A_m}$$

$$S_{11}(s) = \frac{C_3}{1 + \alpha A_m}$$

Want $S_{11}(s)$ to be ideal initial beam shape

Case 1

Case 2

$$C_1 = 0.000251$$

$$C_1 = 0.0002$$

$$C_2 = -0.000251$$

$$C_2 = -0.0001456$$

$$C_3 = 0.009596$$

$$C_3 = 0.0092$$

REFERENCE MODEL SELECTION

PURPOSE: TO DAMP OUT THE STRUCTURAL VIBRATIONS WITHIN TEN SECONDS WITHOUT VIOLATING THE CONTROL MAGNITUDE CONSTRAINTS.

$$\dot{q}(t) = 0.4q(t)$$

$$y_{m1}(t) = C_{m1}q(t)$$

$$y_{m2}(t) = C_{m2}q(t)$$

$$y_{m3}(t) = C_{m3}q(t)$$

$$q(0) = 1$$

RESULTS

0 **FEEDBACK GAINS**

0 **FEEDFORWARD GAINS**

0 **SIMULATIONS**

PARAMETER	VALUE
L = Beam Length	130.0 ft
α = weighting factor	0.25
s = additional beam sensor location	65.0 ft
EI	4.0×10^7 lb-ft ²
PA	0.09556 slugs/ft

TABLE 5.1 : SCOPE BEAM PARAMETERS

MODE #	k_n	ω_n (rad/sec)	f_n (HZ)
1	4.73	27.085	4.311
2	7.853	74.658	11.882
3	10.996	146.378	23.297
4	14.173	243.181	38.703
5	17.274	361.236	57.492

TABLE 5.2 : NATURAL FREQUENCIES FOR CASE I

MODE # n	k_n	ω_n (rad/sec)	f_n (HZ)
1	3.927	18.669	2.971
2	7.069	60.495	9.628
3	10.210	126.199	20.085
4	13.352	215.823	34.349
5	16.493	329.310	52.411

TABLE 5.3 : NATURAL FREQUENCIES FOR CASE II

RECALL THAT FOR TRUE STABILITY WE NEED

$$\underline{f} = \underline{f}^* + G(y_m - y) = \underline{f}^* + GC(v^* - v)$$

THIS SYSTEM WILL BE STABLE FOR

$$G = \begin{bmatrix} G_1 & 0 & 0 \\ 0 & G_{22} & 0 \\ 0 & 0 & G_{33} \end{bmatrix}$$

$$G_{11} > 0$$

FEEDBACK GAINS (NO SENSOR AT s_0)

CASE I

SET A : $G_{11} = 1210.0$ $G_{22} = 1730.0$ $G_{33} = 0.0$

SET B : $G_{11} = 600.0$ $G_{22} = 850.0$ $G_{33} = 0.0$

SET C : $G_{11} = 60.0$ $G_{22} = 85.0$ $G_{33} = 0.0$

CASE II

SET A : $G_{11} = 950.0$ $G_{22} = 300.0$ $G_{33} = 0.0$

SET B : $G_{11} = 475.0$ $G_{22} = 150.0$ $G_{33} = 0.0$

SET C : $G_{11} = 95.0$ $G_{22} = 30.0$ $G_{33} = 0.0$

# modes in series	s_{21}^1	s_{21}^2	s_{21}^3
3	-690.946	-1641.531	-9785.292
4	-690.954	-1044.241	-9188.201
5	-669.460	-1236.139	-8678.003
6	-669.401	-949.532	-8391.477
7	-641.403	-1145.781	-7803.666
8	-641.402	-982.676	-7640.603
9	-631.98	-1066.760	-7320.688
10	-631.916	-959.505	-8279.688
AVERAGE	-658.000	-1127.700	-8279.000

CGT Gains for Case I

# modes in series	S_{21}^1	S_{21}^2	S_{21}^3
3	-355.878	-1141.894	-6309.016
4	-332.129	-805.507	-5354.048
5	-318.384	-1007.015	-4986.424
6	-316.305	-791.389	-4776.447
7	-303.601	-953.259	-4463.880
8	-300.262	-856.221	-4300.704
9	-295.713	-924.748	-4184.084
10	-294.991	-937.512	-4166.822
AVERAGE	-314.235	-926.750	-4817.250

Stavul n rous

Case I : Free-Free

$$G_{11} = 1210$$

$$G_{22} = 1731$$

$$G_{33} = 0$$

$$S_{21} = -669.0$$

$$S_{22} = -949.5$$

$$S_{23} = -8391.5$$

Case II : Simple-Free

$$G_{11} = 950$$

$$G_{22} = 300$$

$$G_{33} = 0$$

$$S_{21} = -316.3$$

$$S_{22} = -791.4$$

$$S_{23} = -4776.4$$

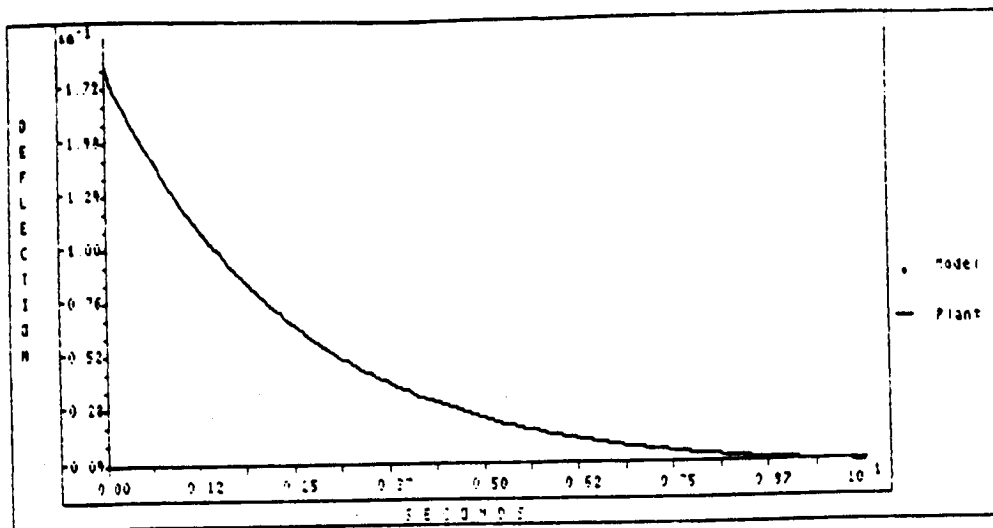

Figure 5.11 Case I : Perfect Model Following -
CGT Gains for 6 Modes

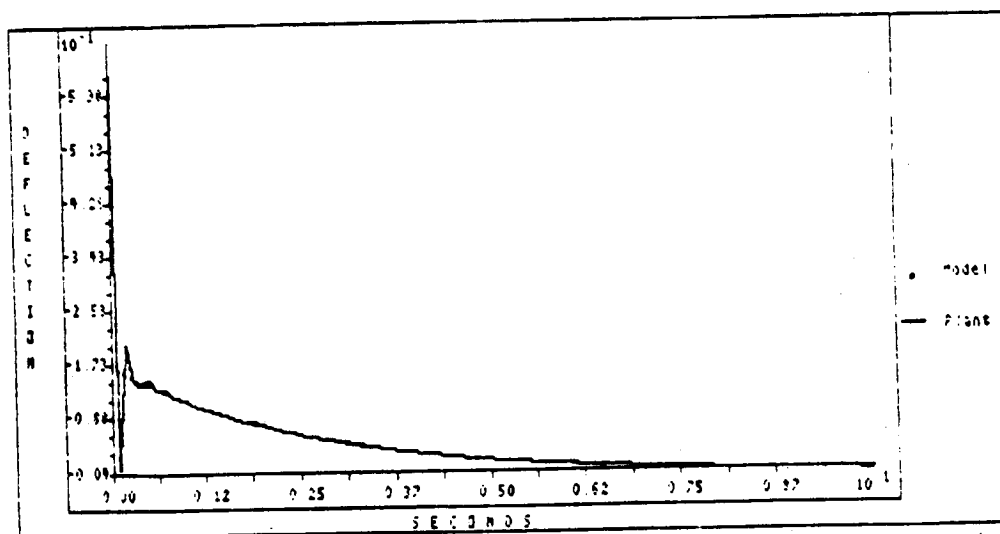

Figure 5.12 Case I : Tracking -
CGT Gains for 4 Modes

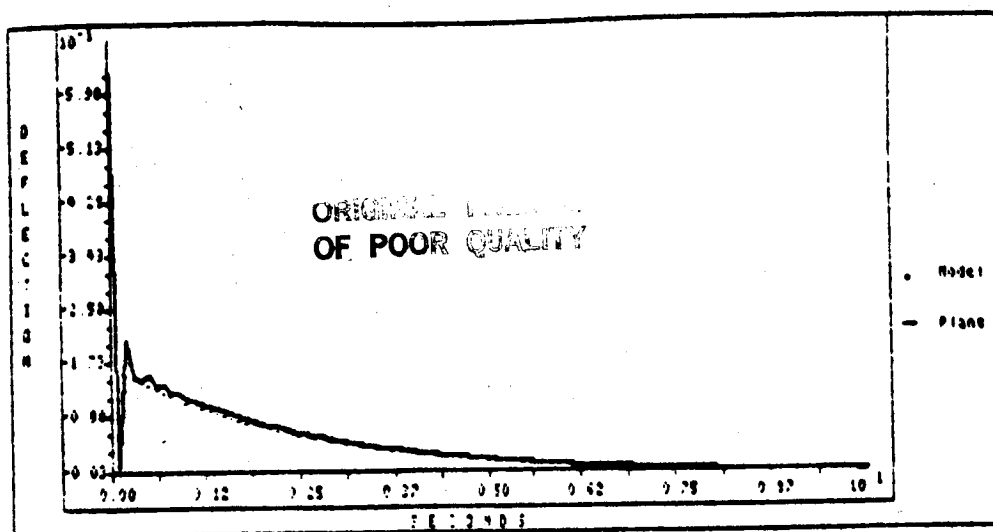

Figure 5.13 Case I : Tracking -
CGT Gains for b Modes

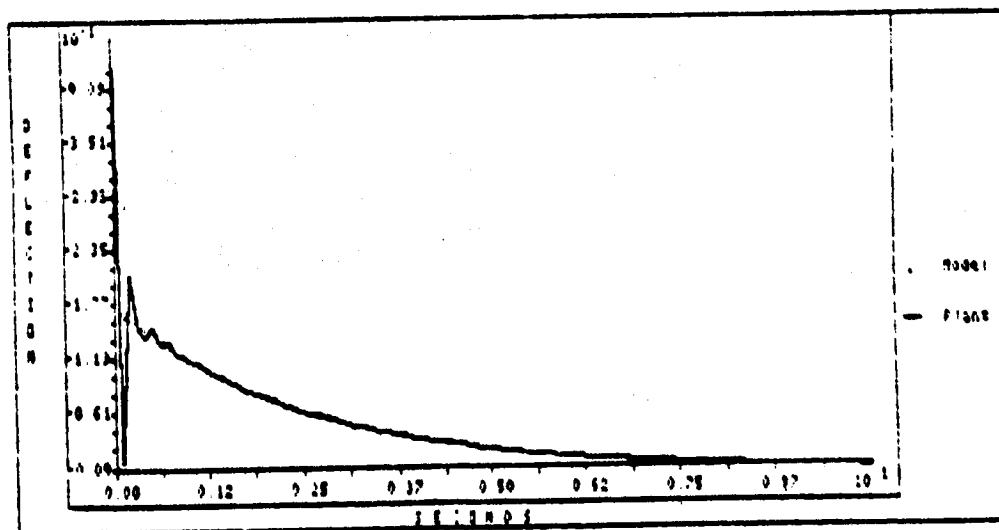

Figure 5.14 Case I : Tracking -
CGT Gains for Ave Modes

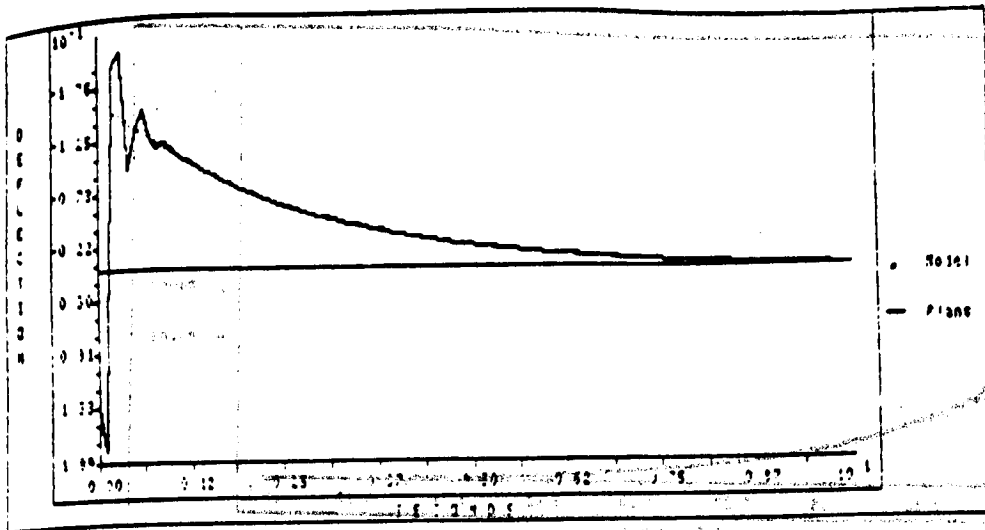

Figure 5.15 Case II : Tracking -
CGT Gains for 4 Modes

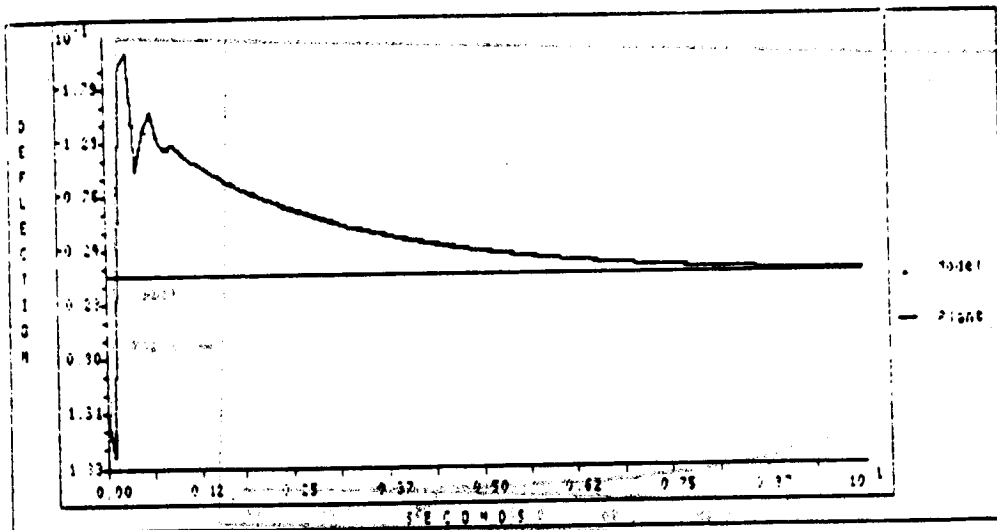

Figure 5.16 Case II : Tracking -
CGT Gains for 16 Modes

ORIGINAL PAGE IS
OF POOR QUALITY

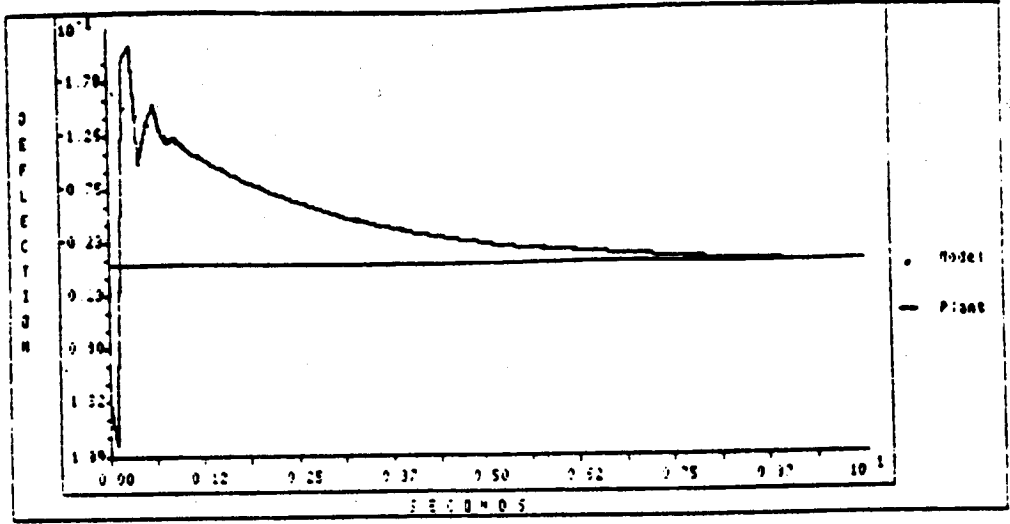

Figure 5.17 Case II : Tracking -
CGT Gains for Ave Modes

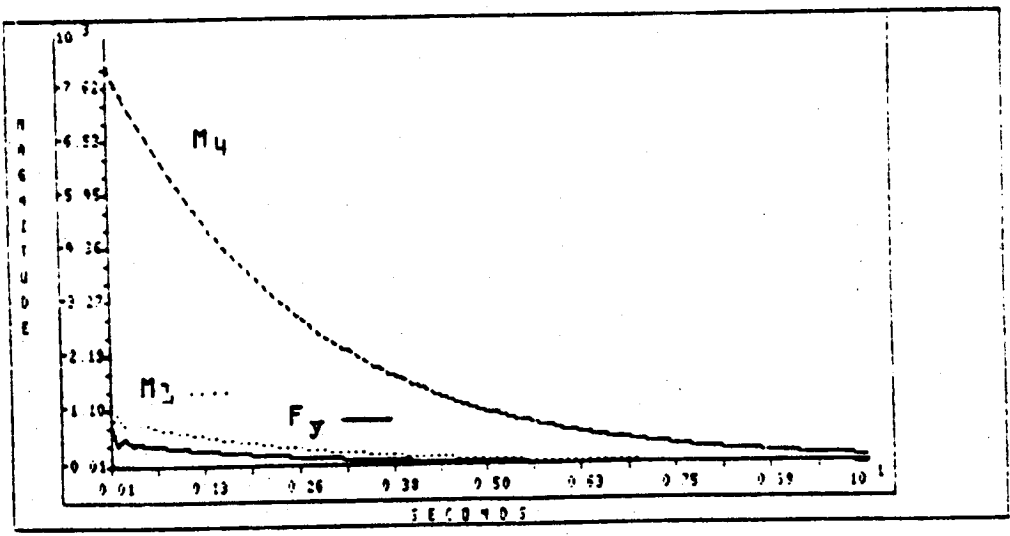

Figure 5.18 Case I : Controls -
CGT Gains for b Modes

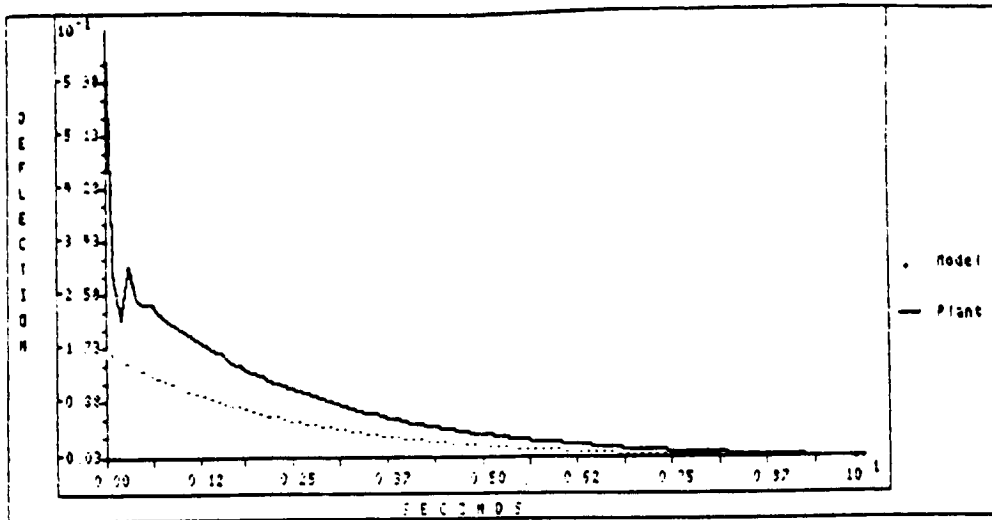

Figure 5.19 Case I : Parameter Variation -
CGT Gains for b Modes

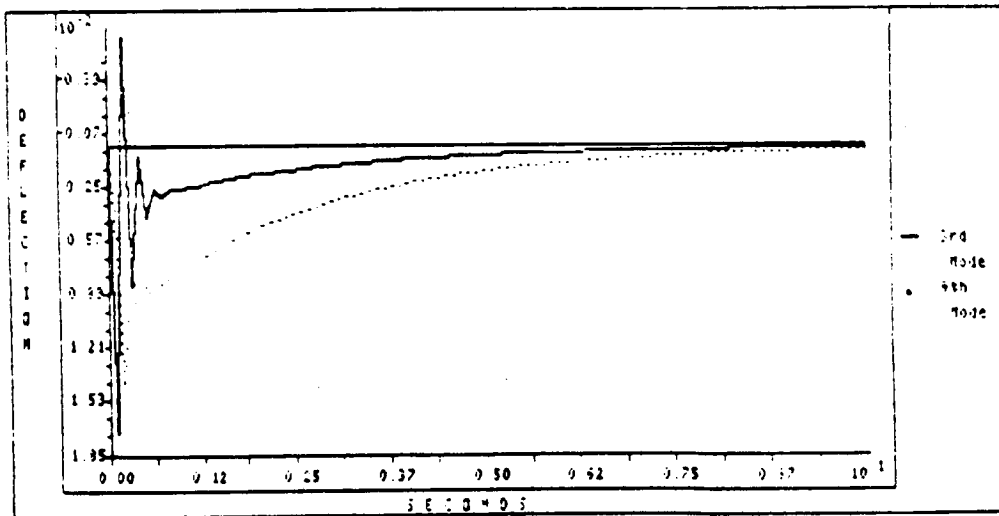

Figure 5.20 Case I : Control Spillover -
Beam Deflection for 3rd and 4th Modes,
CGT Gains for b Modes

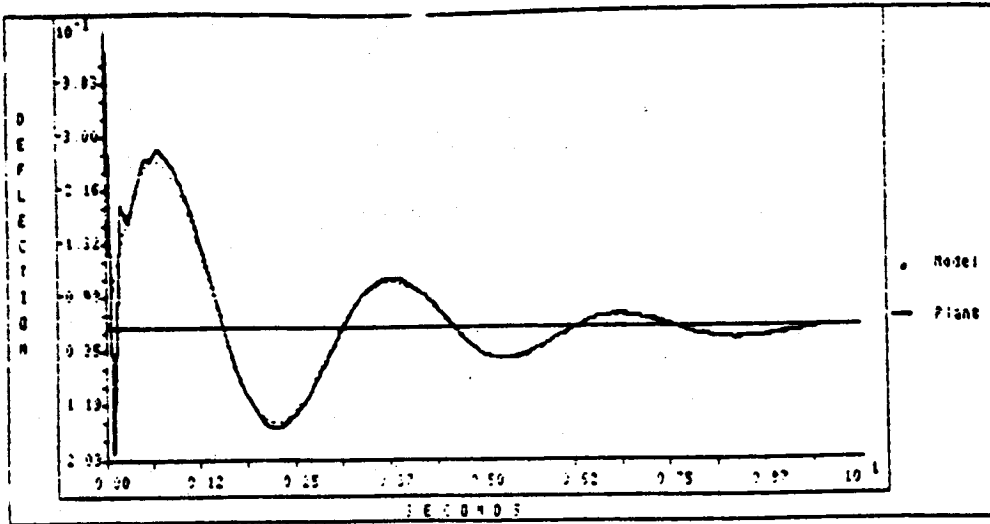

Figure 5.21 Case I : Tracking -
Reference Model $2.04 e^{-.4t} \sin (2.04t)$,
CGT Gains for b Modes

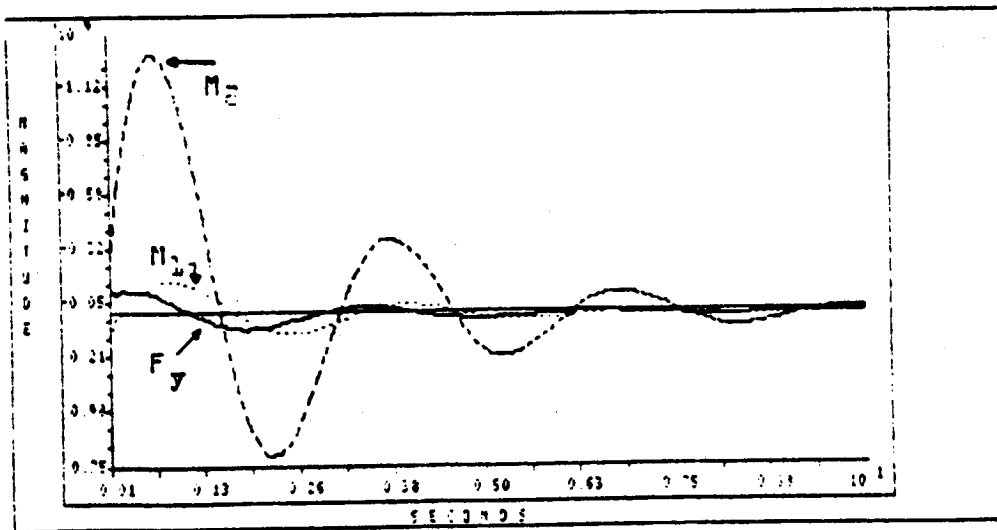

Figure 5.22 Case I : Controls -
Reference Model $2.04 e^{-.4t} \sin (2.04t)$,
CGT Gains for b Modes

CONCLUSIONS

1. A MODEL FOLLOWING PROCEDURE USING CGT THEORY WAS DEVELOPED FOR APPLICATION TO DPS SYSTEMS.
2. THE DESIGN PROCEDURE RESULTS IN A FINITE-DIMENSIONAL CONTROLLER THAT GIVES OUTPUT FOLLOWING AND FULL STATE STABILITY.
3. THE MODEL FOLLOWING CONTROLLER'S APPLICATION TO A MODELS OF THE SCOPE WAS SHOWN.
4. THROUGH SIMULATIONS, IT WAS DEMONSTRATED THAT SATISFACTORY TRACKING OF A DESIRED TRAJECTORY CAN BE ACHIEVED.
5. EXCITATION OF HIGHER ORDER MODES BY THE CONTROLLER AND PARAMETER VARIATIONS DO NOT ADVERSELY AFFECT THE SYSTEM PERFORMANCE.

PLANNED ACTIVITIES

- 0 DEVELOPMENT OF OUTPUT FEEDBACK FOR LUMPED MODEL CONTROLLER
- 0 DEVELOPMENT OF CONTROLS FOR THE PITCH AND YAW TORSION EQUATION
- 0 TESTING OF THE CONTROLLERS, IN THE PRESENCE OF NOISY SENSORS.
- 0 ADAPTIVE CONTROL