

**N87 - 17965**

TDA Progress Report 42-88

October–December 1986

# **Ka-Band (32 GHz) Spacecraft Development Plan**

A. L. Riley

Spacecraft Telecommunications Equipment Section

*A road map for the development of a protoflight 32 GHz spacecraft solid state transmitter is given. The major milestones include the development of device and component technology required for use in the spaceborne experimental and operational transmitter systems. Two experimental spacecraft transmitter systems are envisioned: first, a low power beacon, to determine the performance of a 32 GHz downlink communications system; and second, an array feed, to further verify the results of the first experiment and serve as a test bed for technology required for an operational system. The first experiment has been proposed to NASA Headquarters for flight aboard the Mars Observer spacecraft with spacecraft integration in early 1989. The second is to be available for integration aboard a spacecraft such as the Comet Rendezvous Asteroid Flyby (CRAF) mission in the 1990 time frame. These experimental systems are to lead to the development of a protoflight transmitter for subsequent spacecraft integration in 1992, the time frame of the Cassini mission to Saturn.*

## **I. Introduction**

A fair amount of study has been dedicated to the application of spaceborne solid state transmitter systems to 32 GHz deep space communications. This solid-state technology was chosen because most of the missions studied to date appear to benefit most from it. Electron beam devices such as the traveling wave tube amplifier tend to be more attractive for higher power applications. Furthermore, solid-state active arrays give the added benefit of a simple method to compensate for antenna pointing errors due to spacecraft attitude errors by utilizing electronic beam steering (EBS). Hence, the discussions here emphasize solid state technology.

## **II. Solid-State Technology State-of-the-Art**

Gallium Arsenide (GaAs) field effect transistor (FET) devices are just becoming available for moderate power appli-

cations at 32 GHz. Laboratory devices operating with 100 mW of output power with 30% power added efficiency have been demonstrated by the Texas Instruments Central Research Laboratory and others. Sample devices with 1.5 W of output power with 15% efficiency are anticipated to be available in the last quarter of 1986 from Japanese vendors.

Figure 1 is a plot of the output power performance for several devices demonstrated by Texas Instruments and by the General Electric Research Laboratories. These data include performance of both MESFET and MODFET, or HEMT, devices. Typical performance for a 32 GHz HEMT is shown in Fig. 2.

Power-added efficiency is a key element of cost savings for the 32 GHz transmitter. Overall cost of spacecraft power as a function of amplifier system efficiency is shown in Fig. 3 for various levels of transmitter RF power. System efficiency

includes DC power supply efficiency (assumed here to be 85%) and RF to regulated DC power conversion efficiency. It assumes that the cost per Watt of RTG power is \$250K. The cost of power is inversely proportional to efficiency with a cost savings of approximately \$6.5 M for an 8 W transmitter if the efficiency is increased from 15% to 30%. Such an increase in efficiency results in a more than \$1.5 M savings for a 2 W transmitter.

The technology development needs required to implement a high efficiency 32 GHz spaceborne transmitter system focus on FET devices, monolithic phase shifters, array combining, and EBS. The FET devices need improved power handling capability (100–250 mW), improved power added efficiency (greater than 30%), and high reliability (passivation, greater quantities). The monolithic phase shifters need higher frequency of operation and lower loss; the array combining area will concentrate on integrated microwave and feed circuits; EBS requires development of algorithms and software.

### III. Development Approach

Figure 4 lays out a road map for development of a spacecraft transmitter for 32 GHz operation in the Cassini mission time frame. The four elements are the development of transmitter devices, a Ka-band link experiment (KABLE) with the Mars Observer mission, a Ka-band communications experiment (KACE) with the CRAF mission, and a prototype transmitter for the Cassini mission.

The development of high efficiency 32 GHz FET amplifiers and phase shifters will exploit rapidly evolving technology development programs presently funded by DoD and NASA, take advantage of the recently announced \$1 billion (FY 87–91) DoD Microwave/Millimeter Wave Monolithic Integrated Circuit (MIMIC) Program, cooperate with Lewis Research Center in order to focus part of its present Texas Instruments (TI) efforts on JPL needs, and direct JPL funding of FET development to meet specific needs.

The proposed KABLE experiment consists of a transmitter aboard the Mars Observer spacecraft providing a Ka-band downlink to a DSN receiving station. The transmitter consists of a passive frequency multiplier driven by an X-band signal tapped from the power amplifier output to produce a signal at the fourth harmonic (approximately 33.7 GHz) of the X-band downlink. This Ka-band signal is fed to the Mars Observer high gain antenna for transmission to Earth. From the spacecraft transmitter development perspective, this experiment will provide initial experience with Ka-band onboard a deep space spacecraft at very low cost. KABLE is described in detail in an companion article (Ref. 1).

### IV. KACE

A block diagram of the CRAF Ka-band Communications Experiment (KACE) is shown in Fig. 5. The KACE is a down-link beacon system supplementing the prime X-band link. The KACE hardware consists of a Ka-band exciter, a Ka-band amplifier module, and a feedhorn and dichroic subreflector to diplex Ka- and X-band signals. The exciter and amplifier module hardware will be developed for use on CRAF and other Ka-band missions. In later missions, a larger number of these modules will be assembled in an array feed to produce higher power levels.

The amplifier module is one of the more technically challenging aspects of the system. This module is required to have high power-added efficiency (greater than 25%), small size and low cost. One approach to meeting these requirements is to use GaAs monolithic microwave integrated circuit (MMIC) FET devices. The development of devices similar to those required for the KACE system is presently being carried out by TI and funded by Lewis Research Center. Discussions are presently underway to focus this effort toward the development of a device to meet the KACE requirements. Figure 6 is a conceptual drawing of the device and layout of the monolithic circuit consisting of four FET devices on a single GaAs chip. The output stage consists of two parallel FETs driven by two series stages. It is not clear at this point whether a total monolithic structure will yield the greatest efficiency since no tuning of the critical output stage can be done. An alternate approach is to use a discrete output stage mounted in the same package as the input monolithic stages. Several industrial laboratories are presently developing discrete devices. The antenna system will be composed of the baseline Viking antenna with an X-band feed at the focal point. Modifications include the addition of a frequency selective subreflector illuminated by a Ka-band horn feed. A new feed support strut will be required for CRAF, with or without KACE, so that a negligible cost increase will result if the strut is designed to support the subreflector.

Calculations of a Ka-band link with KACE have been made. These assume 0.25 W of amplifier output, 0.2 dB circuit loss, and a Viking antenna with 48.4 dB gain and 0.25 degree pointing error (resulting in 2 dB loss). A typical set of link parameters is given in Table 1 for a 70-meter DSN antenna at a 25 degree elevation angle. A 40 bps data rate can be maintained at Goldstone to 17 AU with 95% link reliability. Assuming the same values of transmitter power, circuit loss, and antenna characteristics, but with different stations, data rate, and range, the performance shown in Table 2 would be maintained.

The KACE will require about 3 W of spacecraft power and could be operated intermittently or continuously during the

cruise phase of the mission. The experiment will measure link performance and acquire link reliability statistical data over varying elevation angles and weather conditions. The mass of the experiment hardware will be of the order of 5 kg or less, and, including the subreflector, the electronics will occupy a volume less than 2,000 cubic cm.

## V. Cassini Strawman Spacecraft Ka-Band Design

The Cassini Ka-band system will be composed of some new components and those demonstrated in the CRAF KACE. The KACE components include the exciter and amplifier modules combined in an active array. New features of the Cassini 32 GHz system include multiple modules, the addition of phase shifters and new radiating elements with each module, and beam steering electronics to compensate for spacecraft pointing errors.

A strawman Cassini 32 GHz downlink system developed by Boreham<sup>1</sup>, and shown in Fig. 7, consists of an active array feed system illuminating a 3.66 meter high gain antenna by way of a Cassegrainian subreflector. The subreflector is a frequency selective design to allow illumination of the high gain antenna by X- and S-band feeds at the focal point. The X-band feed is used for communications uplink and back-up downlink, and the S-band is used for a radio science experiment. One promising design that was investigated consisted of a 21 element array with five elements across the array and an element spacing of 1.8 wavelength. Since the half-power beam angle of the 3.66-meter reflector at 32 GHz is 0.18 degrees, and the Mariner Mark II baseline attitude pointing accuracy is 0.11 degrees, with a resulting scan loss of as much as 4 dB, either greater spacecraft stability or beam steering was required.

The strawman design assumes EBS by the array controlled by attitude sensors, which reduces the scan loss to 0.5 dB. The spaceborne 32 GHz system consists of an exciter similar to the type developed for the KACE with the active array. Major elements of the active array are a low loss power distribution system, a set of phase shifters, amplifier modules and radiating elements and the beam steering control system. The amplifier is similar to those developed for KACE. These modules produce output power levels of 0.1 W so the 21 element

EBS array feed power amplifier (AFPA) radiates 2.1 W of RF power into a 3.66-meter HGA and supports the same data rate as a previously proposed X-band baseline system. That X-band system consisted of redundant 10.6 Watt solid-state amplifiers (SSAs). The Ka-band and X-band designs were assumed to have the same fixed mounted HGAs and use the same attitude control accuracy of 0.05 degree. It was assumed that the attitude control system provides the only X-band beam pointing, but the Ka-band beam is provided with additional fine pointing with EBS. The attitude control system provides the Ka-band EBS controller with deadband position information to accomplish the vernier pointing. Details of the control system are shown in Fig. 8.

Figure 9 is a schematic diagram of the Ka-band EBS AFPA. The assembly consists of 21 ports, redundant DC to DC power converters, and redundant EBS controllers. The legend below the block diagram in Fig. 8 shows the RF power levels at the array and FET module inputs to and the outputs for the Ka-band configuration. The Ka-band exciters will use power output modules similar to those in the AFPA modules. A 4.0 dB transmission loss from the exciters (through the hybrid) and to the AFPA input and the power divider loss sets the input power levels shown in Fig. 9. The output levels from the modules are set by the required total radiated power divided by the number of elements in the array.

Figure 10 shows details of the FET module designs, which include an input phase shifter, a monolithic gain stage, a discrete driver stage, a final high efficiency power stage, and an output isolator. It has been assumed that efficiencies of discrete devices in the 30 to 100 mW output level range will equal or exceed 30% in production units by 1991. (This assumption is reasonable by the technology cut-off year for a 1995 Cassini launch based on the present rate of technology advances.) Assuming a DC to DC converter efficiency of 85%, and 1.5 W for the EBS controller, results in a total of 11.4 W for the 21 element array. Mass estimates for the EBS array feed portions of the Ka-band system are shown in Table 3.

## VI. Conclusion

A development plan has been laid out to prepare the solar system exploration program to exploit Ka-band for downlink operation by the mid 1990's, in time for the Cassini mission. The plan takes advantage of development by other agencies where that is possible, with adoption of those developments for deep space applications. Flight experiments are considered as well as a protoflight model.

<sup>1</sup>Boreham, J. F., "A 21 Element EBS Array Feed for the SOTP Spacecraft," JPL IOM 3360-86-030 (internal document), Jet Propulsion Laboratory, Pasadena, California, October 22, 1985.

## References

1. Riley, A. L., et al., "A Ka-band Link Experiment (KABLE) with the Mars Observer," *TDA Progress Report 42-88*, Jet Propulsion Laboratory, Pasadena, California, February 1987.

**Table 1. Telecommunications system downlink performance estimate**

Parameter	Design Value
<b>Transmitting System</b>	
RF power output, dBm	24.0
Transmitter circuit loss, dB	-0.2
Antenna Gain (referenced to CP), dB	48.4
Antenna ellipticity, dB	1.5
Antenna pointing loss, dB	-2.0
<b>Path Parameters</b>	
Space loss (where range = 17.5 AU and frequency = 31.9 GHz), dB	-310.9
<b>Receiving System</b>	
Antenna gain for matched polarization, dB	84.8
Antenna ellipticity, dB	1.0
Antenna pointing loss, dB	-0.2
Noise spectral density, dBm/Hz	-183.3
System noise temperature, K	33.7
Zenith noise temperature, K	23.2
Additive noise for elevation angle, K	10.5
Elevation angle, deg	25
<b>Telemetry Performance Estimate</b>	
Required pt/no. (ranging off), dB Hz	23.5
Data rate, bps	40.0
Required $E_B/N_0$ , dB	4.2
Required carrier margin, dB	10.4
Modulation level (RMS), deg	43.3
Performance margin, dB	3.8
Link reliability	1.0
Sigma, dB	0.7

**Assumptions:**

Ka-band/0.25 W KSSPA/HGA circuit  
 Ka-band/1.47 M body-fixed HGA/0.25 deg pointing error  
 DSN 70 M station/Ka-band/mechanical compensation/PE = 0.001 deg.  
 Goldstone/extrapolation from Ka-band noise temperature measurements/worst  
 DSN Block III receiver/10.8 Hz bandwidth mode  
 Telemetry channel/Viterbi (K=7,R=1/2,Q=3), 40 bps, PB=1.E-3

**Table 2. KACE telemetry performance estimates**

Station	Maximum Range, AU	Data Rate, bps
Goldstone	17.4	40
Goldstone	5.6	768
Canberra	13.7	40
Canberra	5.6	454

**Table 3. Mass estimates of Cassini Ka-band EBS array feed**

Components	Mass/Unit, g	Number of Units/Assembly	Mass, g
FET Module	12	21	250
Phase Shifter	9	21	190
Isolator	5	21	105
Array Element	5	21	105
Power Splitter	150	1	150
Power Converter	950	2	1900
EBS Controller	600	2	1200
Structure	250	1	250
Wiring	100	1	100
Hardware	100	1	100
<b>Total Mass</b>			<b>4350</b>

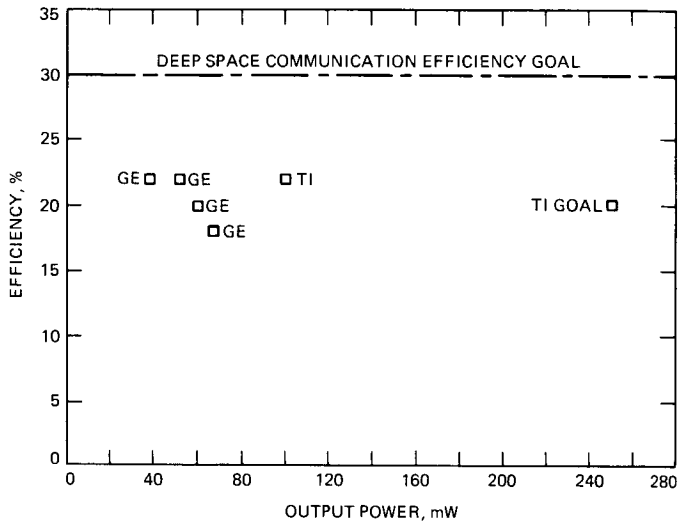

Fig. 1. State-of-the-art FET performance, 32 GHz

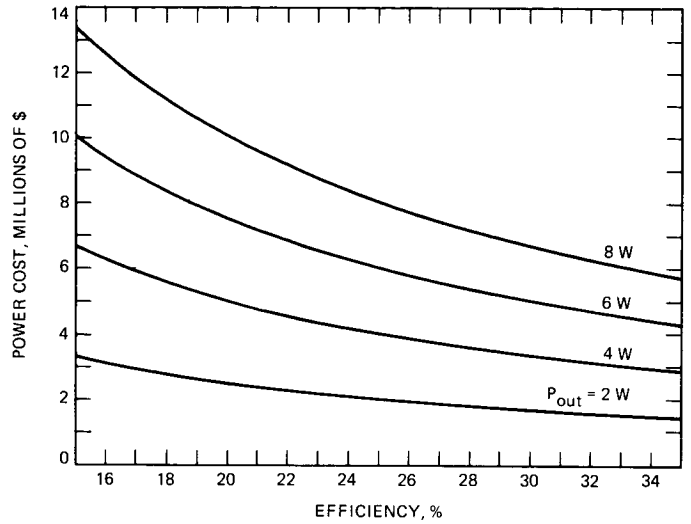

Fig. 3. PA power cost vs efficiency

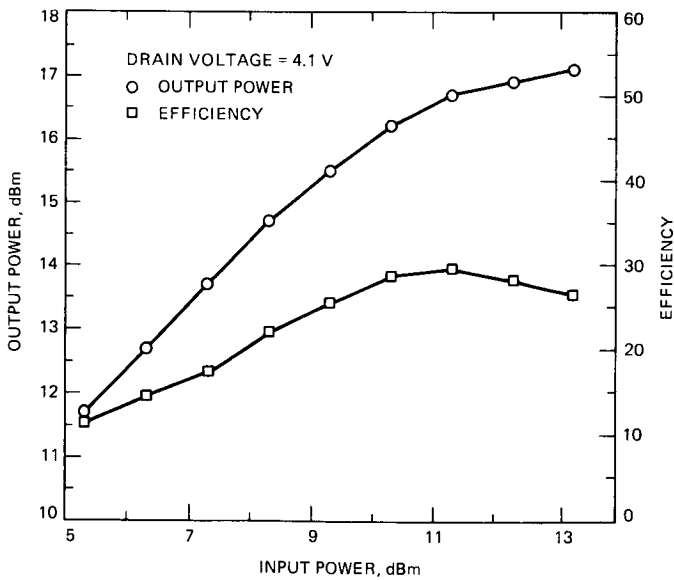

Fig. 2. Gain compression of a 32.5 GHz HEMT

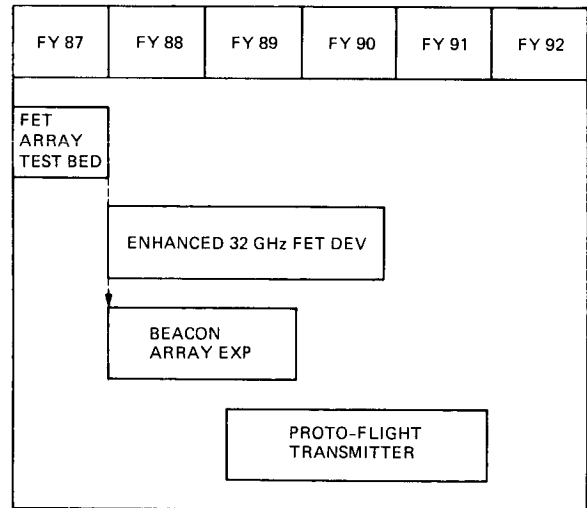
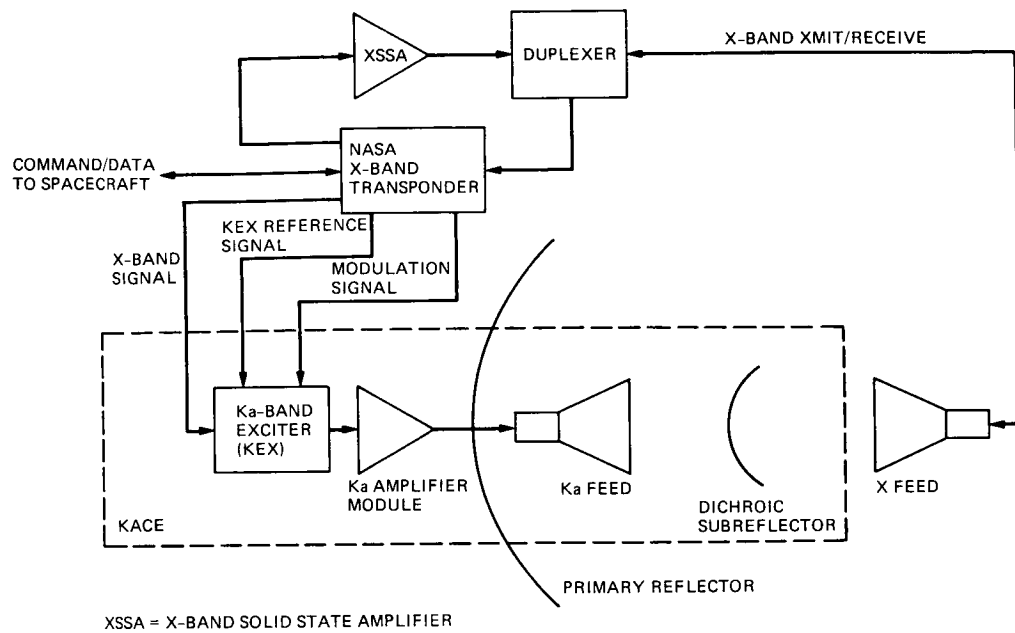
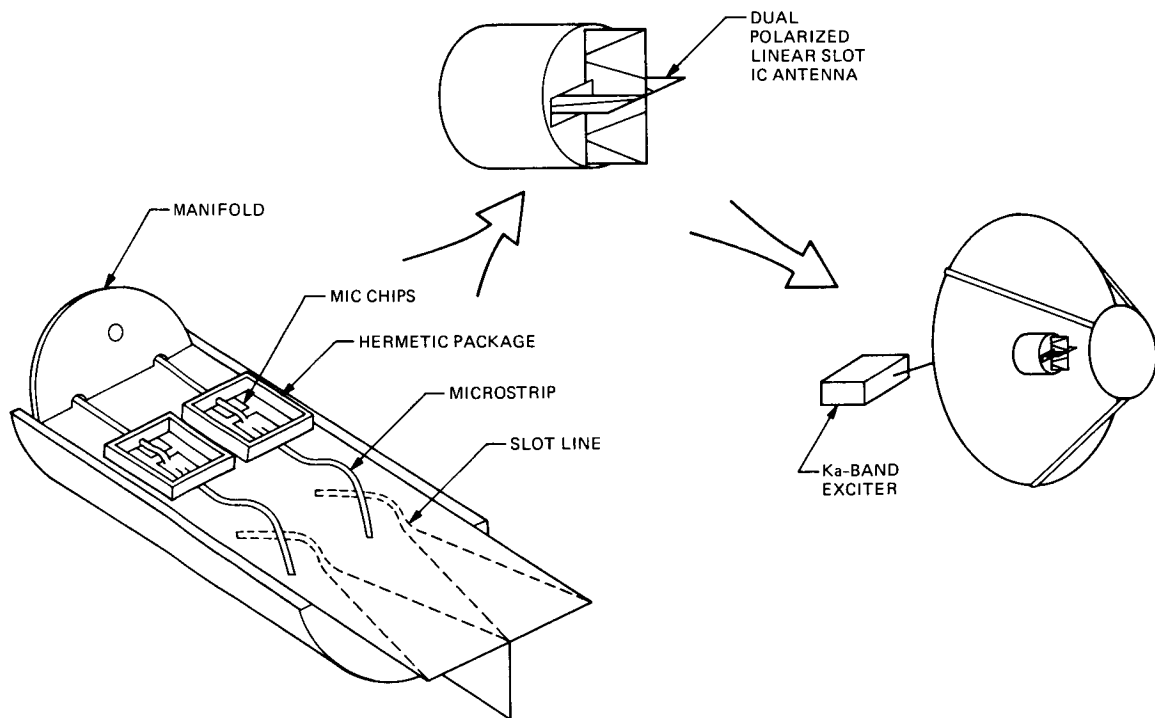

Fig. 4. Development of the 32 GHz space transmitter



**Fig. 5. Interfaces for the CRAF Ka-band communications experiment (KACE)**



**Fig. 6. Configuration of the Ka-band beacon experiment system**

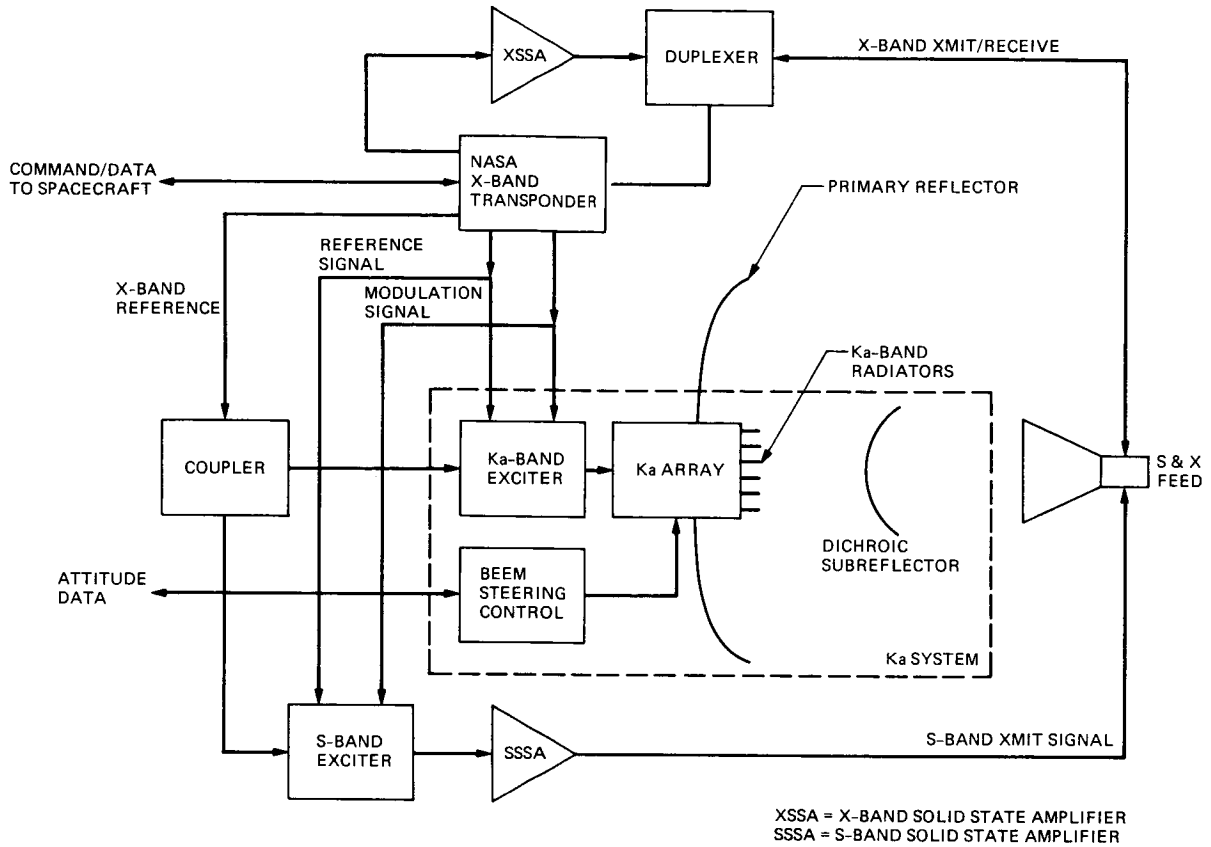

Fig. 7. Cassini Ka-, X-, and S-band communications system

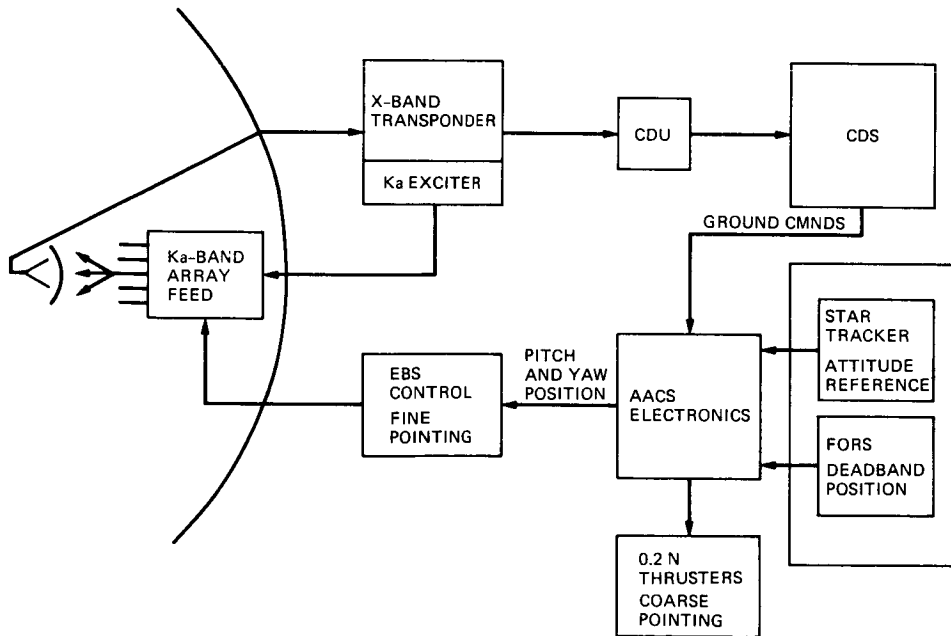

Fig. 8. Functional block diagram of the EBS antenna pointing system



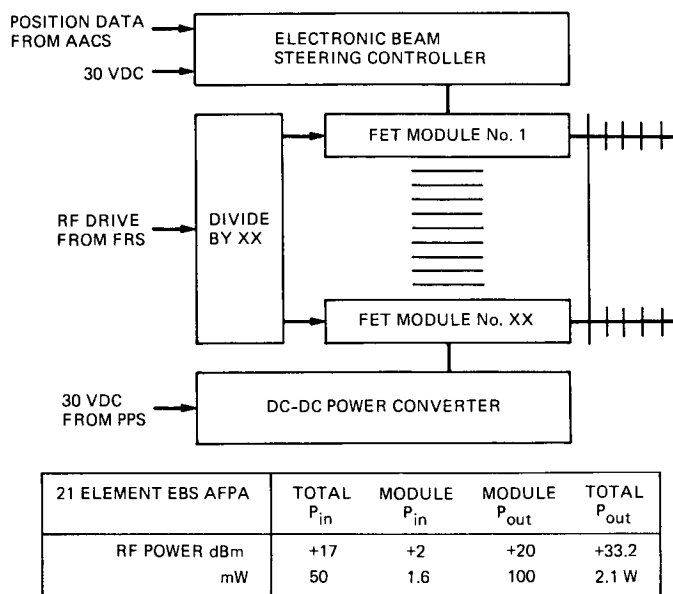
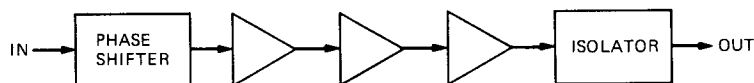

Fig. 9. Block diagram of the Ka-band EBS AFPA



21 ELEMENT FET MODULE, 3.66 m HGA

DEVICE TYPE	PHASE SHIFTER	MONOLITHIC GAIN STAGE	DISCRETE DRIVER STAGE	DISCRETE POWER AMP	ISOLATOR	TOTALS
POWER LEVEL, dBm	+2.0	0	+10.0	+15.3	+20.3	+20.0
GAIN/LOSS, dB	-2.0	+10	+5.3	+5.0	-0.3	+18.0
EFFICIENCY, %	-	15	25	30	-	25.0
DC POWER, mW	-	60	95	245	-	400

Fig. 10. The 21-element Ka-band AFPA FET module design

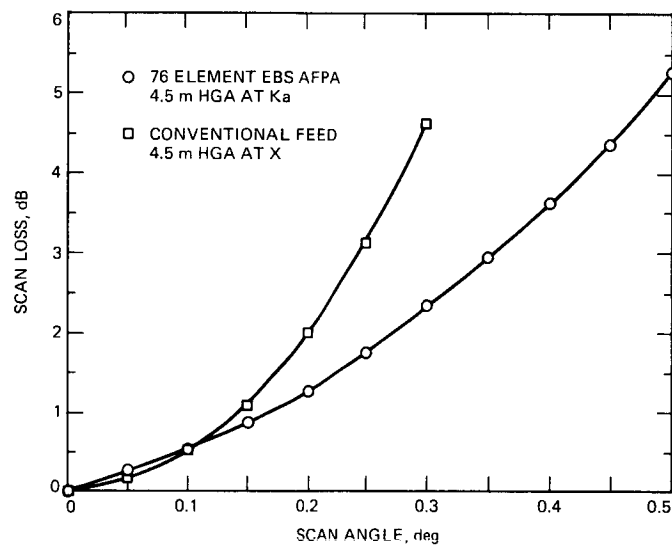

**Fig. 11. The 4.5-m HGA scan/pointing losses for EBS AFPA and conventional feeds**