

N87-18251**GAS FILTER CORRELATION RADIOMETRY: REPORT OF PANEL**

H. G. Reichle, Jr.* (Chairman)
A. A. Barringer, R. Nichols, and J. M. Russell III

To measure the concentration of a gas in the troposphere, the gas filter radiometer correlates the pattern of the spectral lines of a sample of gas contained within the instrument with the pattern of the spectral lines in the upwelling radiation. It has very-high-energy throughput, and it is able to take advantage of multiplexing since all wavelengths within the rather broad passband reach the detector at the same time. The effective resolution can be made very high since it is determined by the properties of the internal gas cell. Because the instrument does use internal gas cells as sources of the reference spectra, any single instrument can only measure a limited number of gases. In general, instruments can be built that are rugged and lightweight, require modest amounts of power, and have low data rates.

A schematic diagram of a generalized gas filter radiometer is shown in figure 9. Energy that has been emitted by or reflected from a background target is transmitted through the atmosphere to the instrument. The individual gases within the atmosphere selectively absorb and re-emit the energy in a pattern of lines that is unique to each particular gas. If the atmosphere is cooler than the radiation source, which may be either the Sun or the surface of the Earth, the gas removes a net amount of energy from the beam, and the lines are seen as absorption lines. If the atmosphere is warmer than the source, the gas contributes a net amount of energy to the beam, and the lines are seen as emission lines. If the gas in the atmosphere is at the same temperature as the radiation source, the gas emits an amount of energy equal to that which it absorbs and, hence, the atmospheric gas cannot be seen. Clearly, experiments that use reflected sunlight always operate in absorption. After being gathered by the foreoptics, the energy passes through the gas cell modulator to the detectors. In most of the instruments now being used, the signal is synchronously detected at the modulator frequency at the detector output. This signal is related to the degree of correlation between the absorption lines in the incoming energy and the absorption lines of the gas contained in the modulator.

The instruments currently in use can be divided into two basic types, depending upon the type of gas cell modulator used. Instruments of the first type are generally based upon the principle used in the Selective Chopper Radiometer (SCR) first flown on the Nimbus 4 satellite as a stratospheric temperature sounder (Abel et al., 1970). In this implementation of the principle, the incoming radiation is chopped between a fixed pressure and path-length cell containing a sample of the gas of interest and a vacuum cell or another gas cell containing a sample of the gas at a pressure different from that of the first cell. The instrument can be arranged so that the incoming energy passes alternately through the two cells to a single detector or so that the beam is divided and passes through the two cells simultaneously to two separate detectors. Both arrangements have been used to measure carbon monoxide in the atmosphere from an aircraft platform (Acton et al., 1973; and Reichle et al., 1986a). Only the second implementation has been used to measure tropospheric carbon monoxide from a satellite platform (Reichle et al., 1986b). The major advantages of

*Prepared panel report.

the two-cell modulator are simplicity and freedom that one has in selecting cell lengths, pressures, and materials. The major disadvantage of the two-cell modulator is the difficulty in insuring that the two optical legs of the instrument are maintained in a balanced condition; that is, for example, that their optical characteristics do not change differently as a result of environmental influences. Such differential changes usually result in zero-shift related errors. In order to circumvent the differential changes that occurred in early two-cell instruments, a single optical-path instrument was developed at Oxford University. Called the pressure-modulated radiometer (or p.m.r.), this device contains only a single cell, and it is the second type modulator in use. The transmission characteristics of the gas in the cell are changed, or modulated, by means of a piston arrangement that sinusoidally changes the cell pressure. This device has been applied to the measurement of stratospheric and mesospheric temperature and composition in a number of experiments flown aboard the Nimbus satellite series by the Oxford group. The latest of these was the Stratospheric and Mesospheric Sounder (SAMS) experiment flown aboard Nimbus 7. Because of its single optical path, this modulator is inherently free from the difficulties encountered in attempting to balance two different optical paths. Its major disadvantage, in its present implementation at least, is the limited range of mean pressures and pressure differences that can be achieved. A version of this device was evaluated as a candidate for application to the remote sensing of tropospheric species. The results of that study are summarized in Orr and Rarig (1981). The overall conclusions of the study were that, because of the limitations of mean pressure and pressure ratio, the application of the p.m.r. to tropospheric remote sensing was limited.

The next section describes three instruments that have application to remotely measuring tropospheric constituents.

CURRENT GAS FILTER RADIOMETERS

The Gas Filter Radiometer (GFR)

The MAPS experiment flown on the second flight of the Space Shuttle during November 1981 measured the tropospheric carbon monoxide mixing ratio along the sub-satellite track over a period of 12 hours between 38°N latitude and 38°S latitude. Since this was the first measurement of this gas made from a space platform, the instrument will be described in somewhat greater detail than will the other previously mentioned instruments.

The instrument layout is shown in figure 10. This instrument is of the SCR type in that it differences the signal as seen through two fixed cells. The energy enters the instrument through the objective lens and is chopped against a reference blackbody by a rotating chopper. After passing through a field stop, a beam combiner (the function of which will be discussed later) an aperture stop and a broad-band filter. The beam is divided by a series of beamsplitters, and it passes to three detectors. Before reaching two of the detectors, the energy passes through 1-cm-long gas cells. One of these is filled with 76 Torr of pure CO, while the second is filled with 266 Torr of pure CO. The outputs of the three detectors are differenced to form two difference signals, $\Delta V = V_{D3} - V_{D2}$ and $\Delta V' = V_{D1} - V_{D2}$. The output of detector D2 is also demodulated to form a broad-band radiometric signal called V that is indicative of the temperature of the underlying surface. Two internal blackbodies called balance sources are chopped at twice the signal frequency by the rotary chopper. The radiometric difference signal from these targets is combined via the previously mentioned beam combiner and directed onto the detectors. After demodulation at the

detectors, this signal is used to drive an automatic gain control circuit that maintains the instrument in the balanced condition. In spite of the extreme temperature variations encountered on the Space Shuttle flight (caused by the failure of a coolant loop temperature controller), this instrument performed very well.

Because the instrument views the nadir in the 4.67 μm band, the signal received by the instrument is integrated over the depth of the atmosphere. The variation of the signal received, as a function of altitude, is described by a signal function, which is analogous to the weighting function as used in describing the performance of radiometric temperature sounders. The signal functions for the two channels as flown on the STS-2 are shown in figure 11. Since the signal received is proportional to the integral of these curves, it can be seen that both channels receive the majority of their signal from the middle and upper troposphere. Neither channel receives much information from the mixing layer because of the low thermal contrast between the atmosphere and the surface of the Earth.

Figure 12 shows a typical orbit of CO data produced by the MAPS instrument. (Because the sampling rate is high at 1 sec^{-1} , the individual data points are not resolved on this figure.) The open spaces in the trace are caused by the presence of clouds in the field of view, which renders the data nonreducible.

To better demonstrate their global-scale patterns, the data were averaged over 5° latitude by 5° longitude grid squares. The data from the higher pressure channel presented in this way are shown in figure 13. The strong variations of the mixing ratio with both latitude and longitude in the Tropics and in the Northern Hemisphere are clearly shown. These global-scale patterns in the CO data, which are so evident in the satellite data, would have been very difficult to measure, either from surface-based or aircraft-based platforms.

The Halogen Occultation Experiment (HALOE)

Another gas filter radiometer similar in principle to the MAPS instrument has been built by NASA as part of the Upper Atmosphere Research Satellite (UARS) which will be launched during 1989. This instrument measures vertical profiles of several constituents in the stratosphere by viewing the Sun during sunrise and sunset as seen from the spacecraft. A schematic diagram of the instrument is shown in figure 14. Because the Sun is now the radiation source, the field of view of the instrument is much narrower. Only a single balance source is required. As can be seen from table VI, the instrument has eight channels--four are gas-filter channels and four are broadband radiometer channels, and these channels span the range from 2.5 to 10 μm . A dichroic beamsplitter is used to separate the radiation prior to its passage through the gas cells. At the present time, this instrument represents the highest development of an SCR-type gas filter radiometer as a spaceborne remote sensor.

Gas Filter Correlation Spectrometer Developed at Centre for Research for Experiment Space Science (GASCOFIL)

While this instrument is not now being developed for a space application (as are MAPS and HALOE), it incorporates certain new ideas (or advancements on old ideas) that cause it to be important for any new instrument development. The instrument, like the original SCR, is a single-detector instrument rather than a multiple-detector instrument as are MAPS and HALOE. In this implementation of the technique, the difference signal is formed on the single detector by varying the cell that is in

the optical path. This was previously done by means of a rotary or vane chopper and a system of mirrors. In the GASCOFIL instrument, this is accomplished by mounting the gas cells and vacuum cells in a rotary wheel and rapidly spinning the wheel through the optical path. The detector then sequentially "sees" the scene through the gas cells and vacuum cells. Between each gas cell and/or vacuum cell view of the scene, the detectors "see" the spokes of the wheel. The output of the detector is amplified and immediately digitized. The signal corresponding to each cell or spoke is then stored in a separate memory location of a microprocessor-based computer. Because all signals are handled as digital rather than analog data, the problems of amplifier drift are greatly reduced. Further, it is possible to adjust certain parameters (averaging time, for example) in the software of the microprocessor rather than the hardware. This considerably increases the flexibility and adaptability of the instrument.

The GASCOFIL instrument has been operated in a portable mode to measure SO₂ in a power plant plume in Ontario, Canada, with excellent results. This application used wavelengths in the near UV. Tests to measure CO using the 4.67 μm band are planned.

CAPABILITY FOR REMOTELY SOUNDING TROPOSPHERIC CARBON MONOXIDE

A set of preliminary calculations to determine the feasibility of performing a multiple-layer, tropospheric carbon monoxide measurement experiment has been carried out. The calculations assume a U.S. Standard Atmosphere for the temperature profile and a typical value for the CO mixing ratio. The air is assumed to be in thermal equilibrium with the underlying surface, which was either land or water. Both the 4.67 and 2.33 μm bands were investigated. The line-by-line radiative transfer program was the same as that used in the reduction of the MAPS data. The results of these calculations are shown in figure 15 and table VII. It can be seen that a three-layer measurement in the troposphere is feasible. The signal functions for the two higher altitude channels are generally similar to those of the OSTA-1 MAPS experiment; they have been made somewhat narrower by varying the cell conditions. The signal levels are of the same order as those achieved by the MAPS experiment. To make measurements in the mixing layer where the temperature contrast between the surface and the gas is small, it is necessary to use reflected sunlight in the 2.33 μm region. (This, of course, limits the measurements to daytime only.) The signal levels are now about 2 orders of magnitude lower than those obtained in the longer wavelength channels. Measurement of the reflected sunlight component will require some engineering advance over the MAPS instrument, both in terms of noise level and stability. This will require some engineering development, but it should require no new technology. The calculations summarized in figure 15 and table VII assume a generic gas filter radiometer. Therefore, any instrument capable of chopping between the indicated cell lengths and pressures with the appropriate noise level and stability would be capable of making the measurement.

RECOMMENDATIONS

This group feels that the following is an appropriate evolution of a tropospheric measurement program using gas filter radiometry.

Now to 1992

1. Exploit HALOE and/or GASCOFIL technology to design, build, and fly a three-layer tropospheric CO measurement and to fly it on a NOAA operational satellite.
2. Test the feasibility of measuring CH₄ by modifying the current MAPS instrument and flying on a Space Shuttle flight.
3. Carry out studies to determine the feasibility of measuring other trace gases.

1192 - 2001

1. Build a multiple-level CO instrument for EOS that includes the capability of measuring CH₄ and other gases as shown feasible via numerical simulations and flight tests.
2. Perform feasibility studies of an instrument that replaces the gas cell with an etalon; O₃ and NH₃ are candidate gases.

2001 - Beyond

1. Build advanced instrument based on results of number 2 above.

REFERENCES

- Abel, P. G., P. J. Ellis, J. T. Houghton, G. Peckham, C. D. Rodgers, S. D. Smith and E. J. Williamson, The Selective Chopper Radiometer for Nimbus D, Proc. Roy. Soc., London, A-320, 35, 1970.
- Acton, L. L., M. Griggs, H. D. Hall, C. B. Ludwig, W. Malkmus, W. D. Hesketh and H. G. Reichle, Jr., Remote Measurement of Carbon Monoxide by a Gas Filter Correlation Instrument, AIAA J., 11, 899-900, 1973.
- Orr, H. D. III and P. L. Rarig, Preliminary Feasibility Analysis of a Pressure Modulator Radiometer for Remote Sensing of Tropospheric Constituents, NASA TM 81958, 1981.
- Reichle, H. G., Jr., H. A. Wallio, J. C. Casas and E. P. Condon, The Gas Filter Radiometer for Carbon Monoxide Measurements During the 1979 Summer Monsoon Experiment, J. Geophys. Res., 91, 9846-9848, 1986a.
- Reichle, H. G., Jr., V. S. Connors, J. A. Holland, W. D. Hypes, H. A. Wallio, J. C. Casas, B. H. Gormsen, M. S. Saylor and W. D. Hesketh, Middle and Upper Tropospheric Carbon Monoxide Mixing Ratios as Measured by a Satellite-Borne Remote Sensor During November 1981, J. Geophys. Res., 91, 10865-10887, 1986b.

TABLE VI.- HALOE INSTRUMENT CHARACTERISTICS

GAS	CENTER (CM^{-1})	50% POINTS (CM^{-1})		MAX 5% POINT WIDTH
HF	4078	4047 \pm 6	4109 \pm 6	117
HC ₂	2940	2910 \pm 6	2970 \pm 6	108
CH ₄	2891	2870 \pm 6	2912 \pm 6	82
NO	1900	1883 \pm 6	1917 \pm 6	62
CO ₂	3572	3537 \pm 6	3608 \pm 6	128
H ₂ O	1514	1506 \pm 6	1522 \pm 6	29
O ₃	996	976 \pm 6	1017 \pm 6	78
NO ₂	1600	1591 \pm 5	1607 \pm 5	29

TABLE VII.- SUMMARY OF SIGNAL CHARACTERISTICS (ADVANCED SOUNDER)

GAS	ALTITUDE OF SIGNAL PEAK	BAND	SIGNAL LEVEL
CO	0 mb	2.3 μm	$2 \times 10^{-9} \text{ w/cm}^2 \text{ sr}$
CO	450 mb	4.67 μm	$2.5 \times 10^{-7} \text{ w/cm}^2 \text{ sr}$
CO	200 mb	4.67 μm	$1 \times 10^{-7} \text{ w/cm}^2 \text{ sr}$

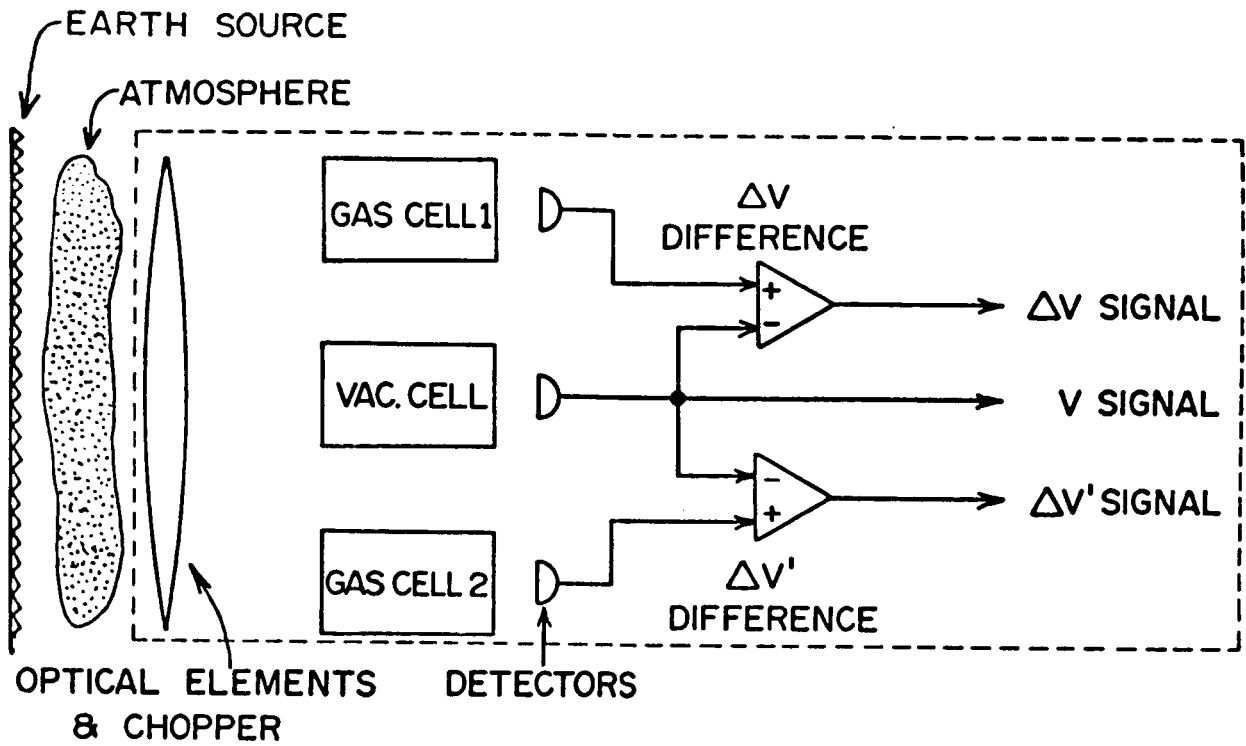

Figure 9.- GFR schematic.

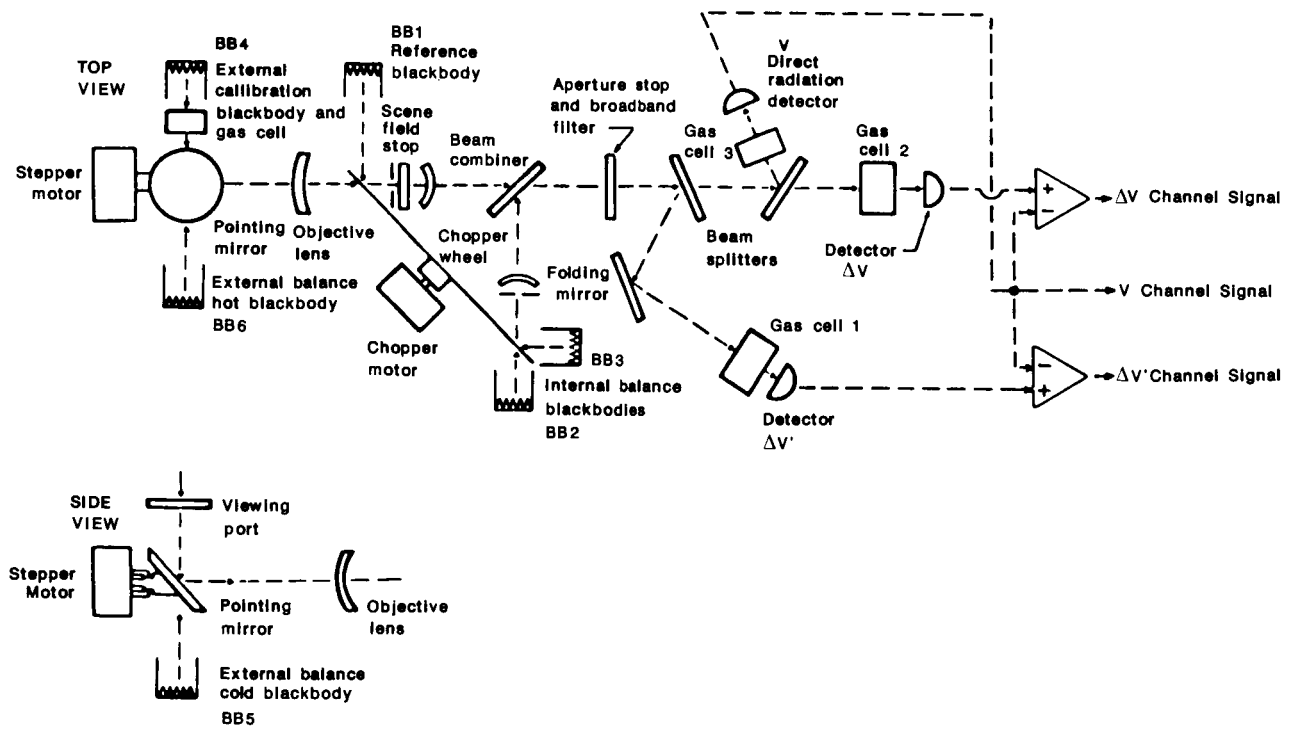

Figure 10.- MAPS instrument layout.

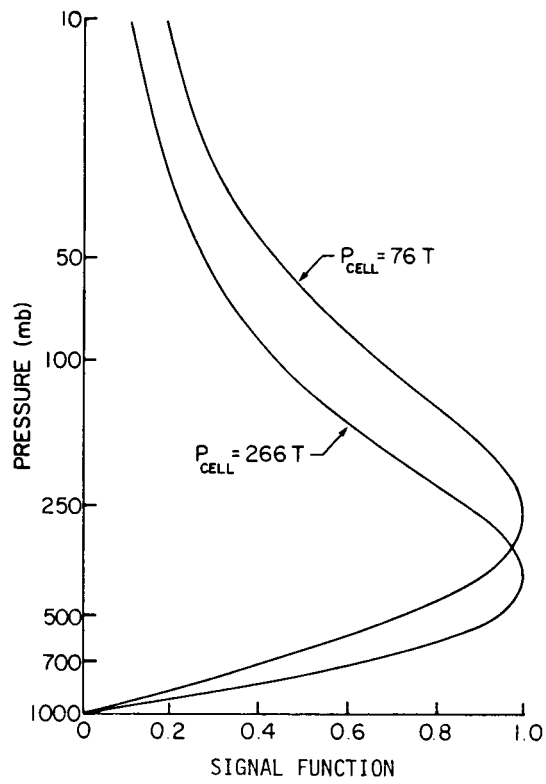

Figure 11.- MAPS OSTA-1 signal functions.

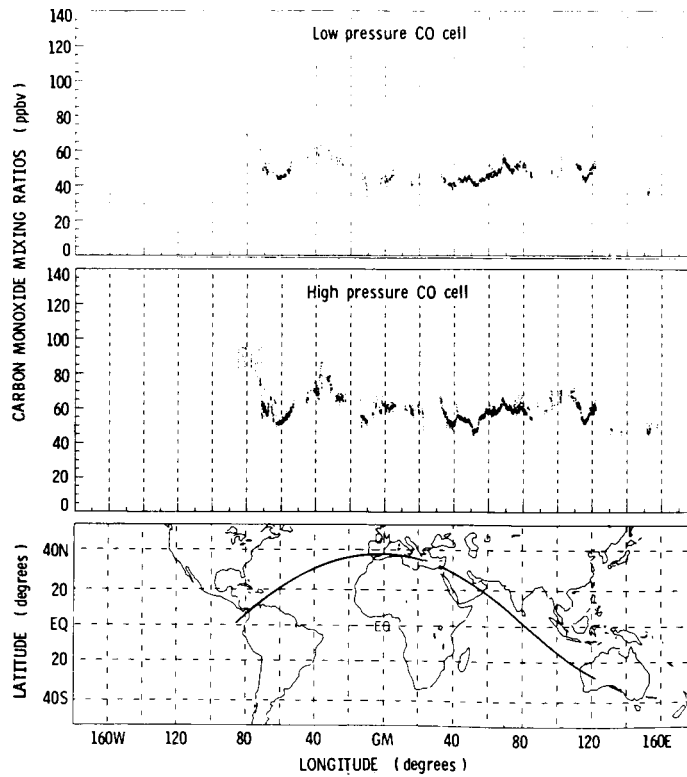

Figure 12.- MAPS data (1 orbit).

MAPS OSTA-1 CO(ppbv) NOV. 14, 1981

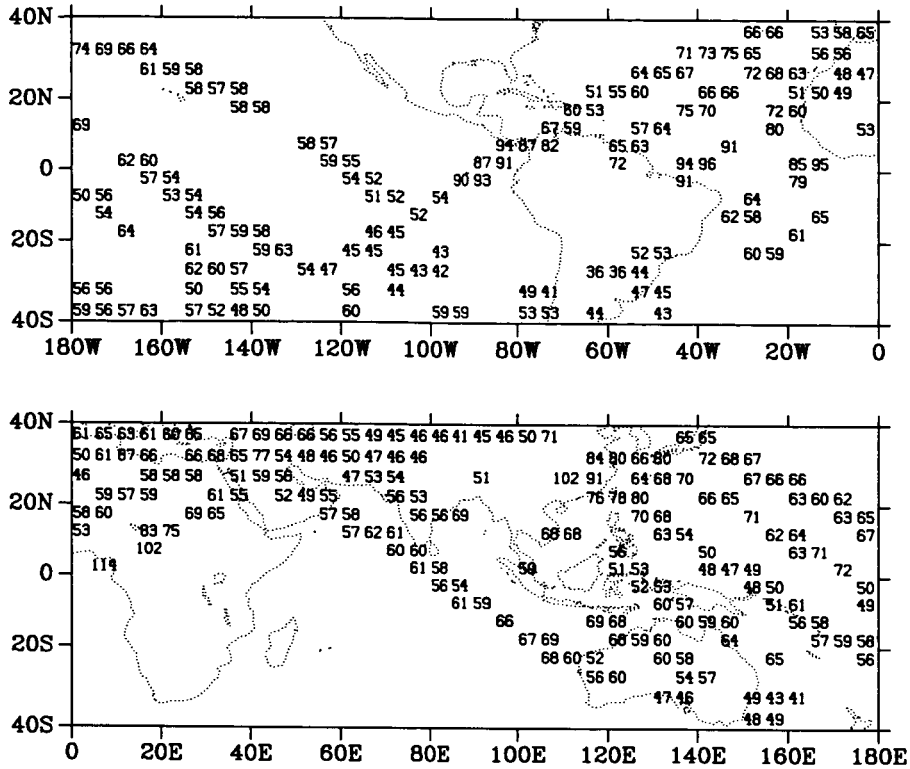

Figure 13.- MAPS data (5° x 5°) 266T.

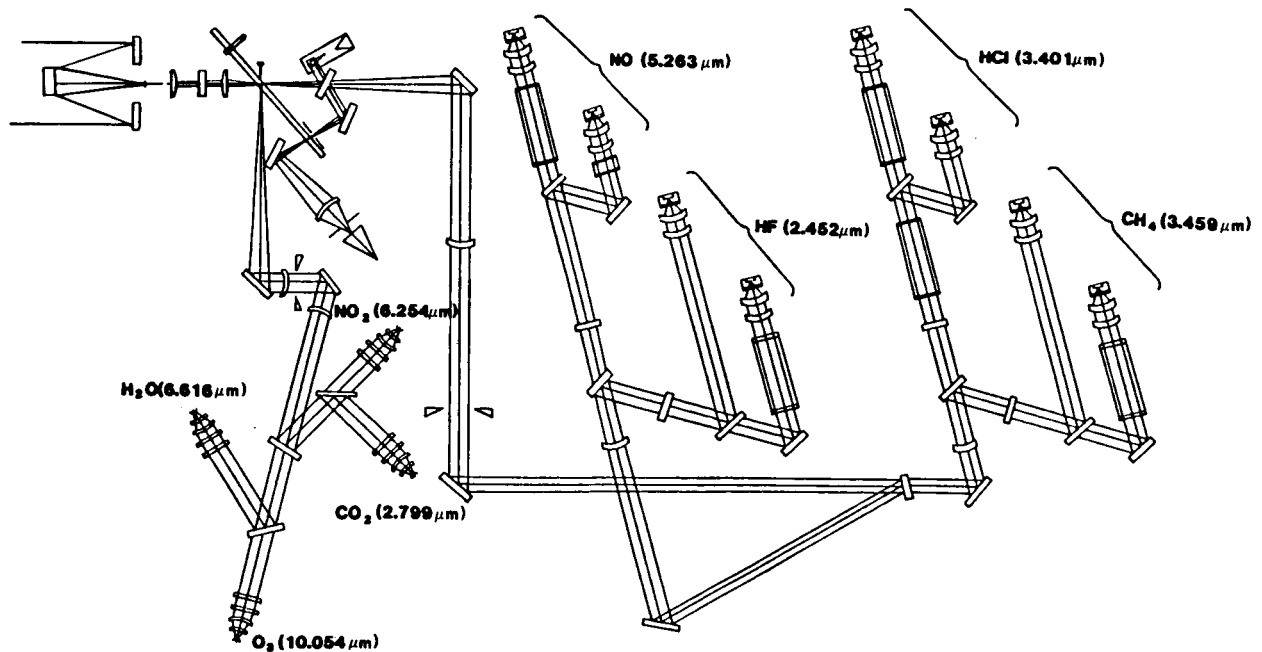

Figure 14.- HALOE schematic.

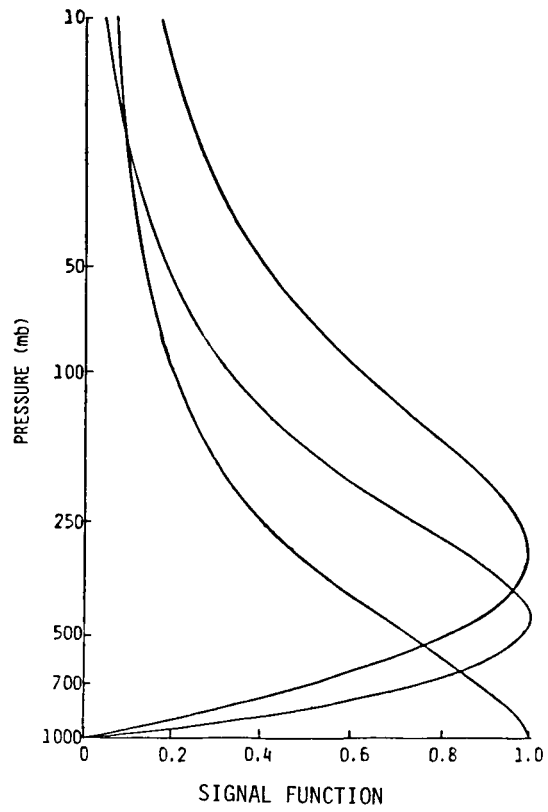

Figure 15.- Signal functions (advanced sounder).