

NASA CASE NO.

MFS-28,161-1

PRINT FIGURE

4

NOTICE

12 P.

The invention disclosed in this document resulted from research in aeronautical and space activities performed under programs of the National Aeronautics and Space Administration. The invention is owned by NASA and is, therefore, available for licensing in accordance with the NASA Patent Licensing Regulation (14 Code of Federal Regulations 1245.2).

To encourage commercial utilization of NASA-owned inventions, it is NASA policy to grant licenses to commercial concerns. Although NASA encourages nonexclusive licensing to promote competition and achieve the widest possible utilization, NASA will consider the granting of a limited exclusive license, pursuant to the NASA Patent Licensing Regulations, when such a license will provide the necessary incentive to the licensee to achieve early practical application of the invention.

Address inquiries and all applications for license for this invention to NASA Patent Counsel, Marshall Space Flight Center, Mail Code CCO1, Huntsville, AL 35812. Approved NASA forms for application for nonexclusive or exclusive license are available from the above address.

(NASA-Case-MFS-28161-1) ORBITAL MANEUVERING
END EFFECTORS Patent Application (NASA)
12 p CACL 131

MSFC
N87-18817

Unclas
G3/37 43595

NASA Case No. MFS-28161-1

Orbital Maneuvering End Effectors

Technical Abstract

This invention relates to an end effector device for grasping and maneuvering objects such as berthing handles of a space telescope.

The device includes a V-shaped capture window (74) defined as inclined surfaces (76, 78) in parallel face plates (22, 24) which converge toward a retainer recess (54) in which the handle is retained. A pivotal finger (30) meshes with a pair of pivoted fingers (26, 28) which rotate in counterrotation. The fingers rotate to pull a handle within the capture window into recess (54) where latches (50) lock handle (18) in the recess. To align the capture window, plates (22, 24) may be cocked plus or minus five degrees on base (64). Drive means is included in the form of a motor 36 coupled with a harmonic drive speed reducer 42, which provides for slow movement of the fingers at a high torque so that large articles may be handled.

Novelty of the invention is believed to reside in the combined intermeshing finger structure, drive means and the harmonic drive speed reducer, which features provide the required maneuverability and strength.

Inventors: W. Neill Myers
John C. Forbes
Wayne L. Barnes

Employer: NASA/MSFC

Patent Application Serial No.: 942,159

Date Filed: December 16, 1986

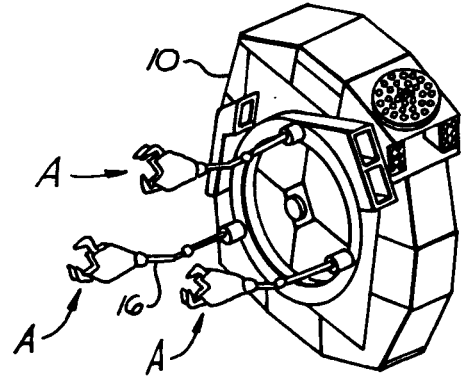
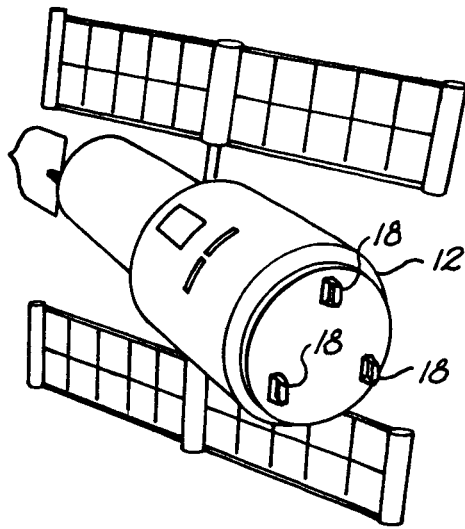

Fig. 1

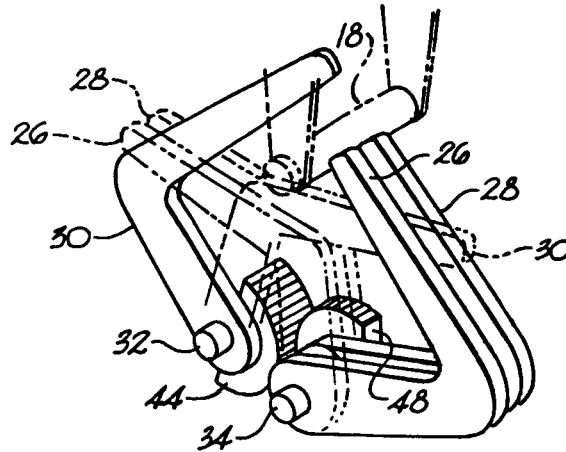

Fig. 4

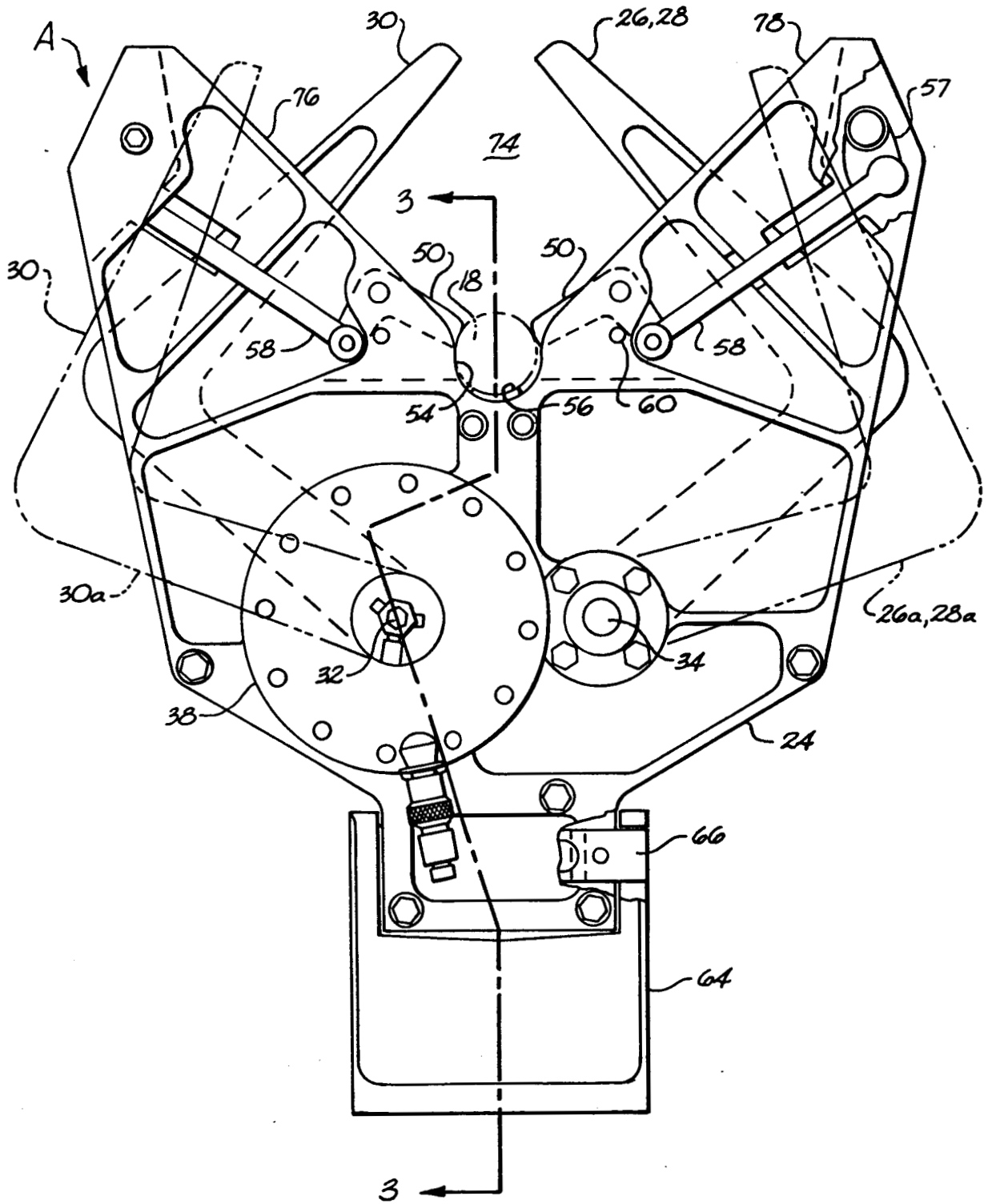

Fig. 2

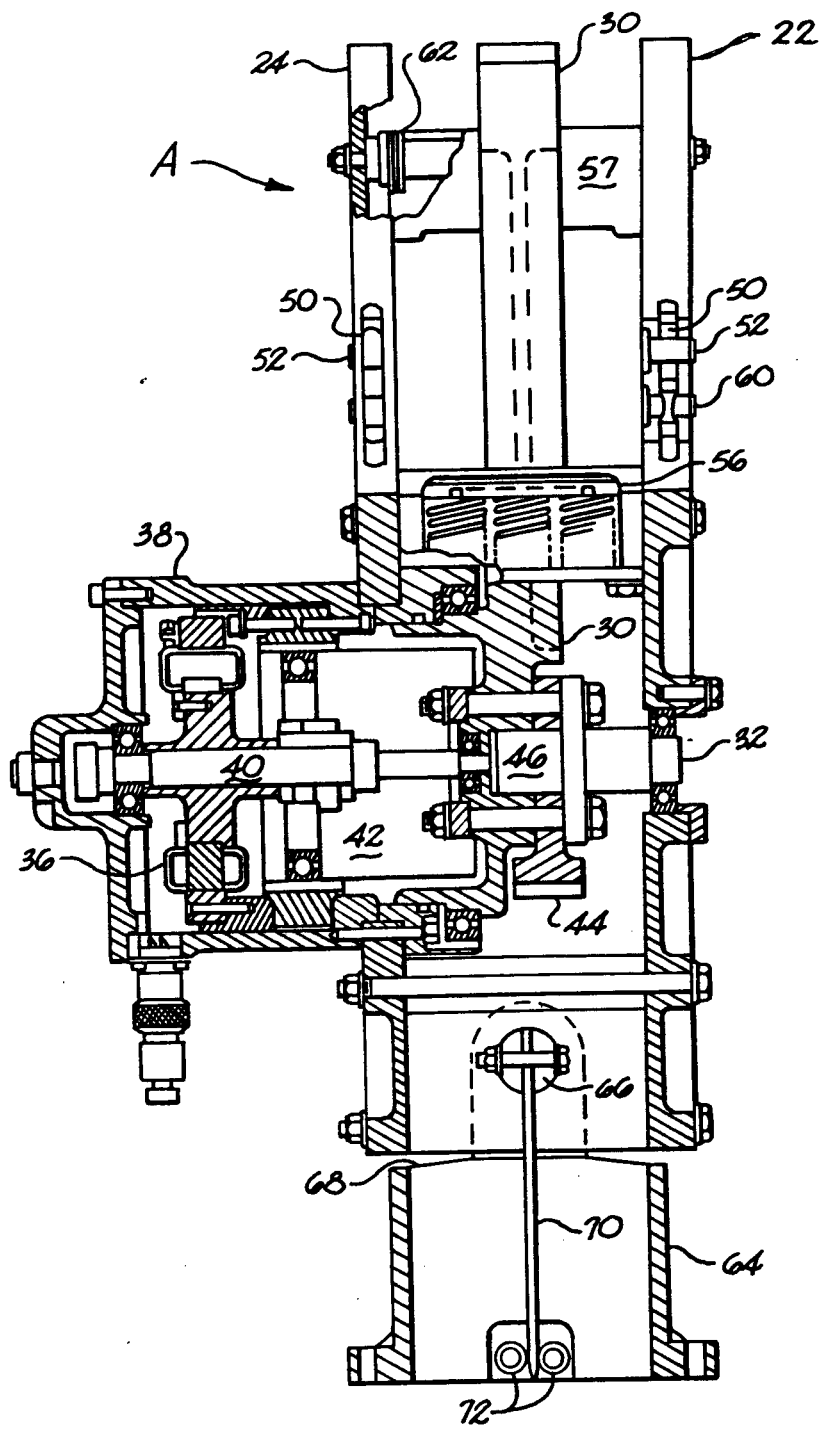

Fig. 3

NASA CASE NO. MFS 28161-1

ORBITAL MANEUVERING VEHICLE END EFFECTORS**Origin of the Invention**

The invention described herein was made by employees of the United States Government and may be
5 manufactured and used by or for the Government for Government purposes without the payment of any royalties thereon or therefor.

Background of the Invention

The invention relates to end effector devices
10 for grasping objects in space and in other applications. In particular, the invention relates to end effectors mounted to an orbital maneuvering vehicle for grasping the berthing handles of a space telescope.

15 While various end effector devices such as those in United States Patent Nos. 3,268,091, 1,025,725, and 4,068,763 have been known, they have not been entirely satisfactory for capturing, gripping and retaining free articles in space. In particular,
20 none of the prior art end effectors have the ability to satisfy all of the unique requirements for the berthing of a space telescope for servicing.

Accordingly, an object of the invention is to provide an end effector device having a relatively
25 large capture envelope for capturing the handles of a space telescope.

Another object of the invention is to provide an end effector device having counterrotating meshing fingers capable of pulling in the handles of a space
30 telescope with at least two hundred (200) pounds force.

Another object of the invention is to provide an end effector device having the ability to capture a handle or other object without precise angular align-
35 ment and particularly wherein the grasping fingers may be cocked within a prescribed interval of degrees with respect to the telescope handles.

Another object of the invention is to provide

an end effector device having the ability to lock the object to the end effector structure once captured to thereby keep the drive mechanism from having to carry the load of retaining the object in the end effector device.

Still another object of the invention is to provide an end effector device having latches which lock the object in the end effector device after capture and which may be released to free the object after servicing of the object.

Summary of the Invention

The above objects are accomplished according to the present invention by providing an end effector device which includes a base and parallel face plates carried on the base in a spaced apart manner. A pair of pivotal fingers are carried by the face plates for rotation in one direction, and an intermeshing finger is pivotally carried by the face plates for rotation in the opposite direction in a manner such that the intermeshing finger and pair of fingers move in a counterrotating fashion for intermeshing. V-shaped guide surfaces are formed in the face plates which taper inwardly and terminate at a recess which conforms in shape generally to that of the object being handled. The V-shaped guide surfaces define a capture envelope in which the object may be captured. Once captured, the counterrotating fingers grasp the object and pull the same into the recess. In the recess, latches are provided for locking the object in the recess and an actuator is provided for locking and releasing the latches. A drive for the rotating fingers is provided by a motor and a speed reducer which reduces the speed but increases the torque of the rotating fingers so that a sufficient pull is provided for pulling in large articles such as the handles of a space telescope. To enhance the capture capability, the face plates may be cocked relative to the base when the space handles are not in

proper angular alignment with the end effector device.

Description of the Drawings

The construction designed to carry out the invention will hereinafter be described, together with
5 other features thereof.

The invention will be more readily understood from a reading of the following specification and by reference to the accompanying drawings forming a part thereof, wherein an example of the invention is shown
10 and wherein:

Figure 1 is a perspective view illustrating an orbital space vehicle having end effectors constructed in accordance with the present invention for berthing with a space telescope;

15 Figure 2 is an elevation view with parts cut away illustrating an end effector device constructed in accordance with the present invention;

Figure 3 is a sectional view taken along line 3-3 of Figure 2; and

20 Figure 4 is a perspective view of intermeshing fingers and counterrotating drive therefor constructed in accordance with the present invention.

Description of a Preferred Embodiment

Referring now in more detail to the drawings,
25 an orbital maneuvering vehicle 10 is illustrated in an earth orbit along with a space telescope 12. The orbital maneuvering vehicle 10 is provided with three end effector devices, designated generally as A, constructed in accordance with the present invention.
30 The end effector devices may be attached by remote manipulator arms 16 which supply power and control to the end effector devices in a conventional manner for operation. Space telescope 12 comprises telescope handles 18 on the end of the telescope. These handles
35 are commonly referred to as berthing handles. These handles are utilized in accordance with the present invention to be grasped by the end effector devices of the orbital maneuvering vehicle. In this manner, the

orbital maneuvering vehicle may be docked with the space telescope for servicing.

As can best be seen in Figures 2 and 3, each end effector device A includes plate means in the form of a pair of spaced parallel face plates 22 and 24. The face plates are separated by rotatable intermeshing finger means in the form of a pair of fingers 26 and 28 and an intermediate finger 30. Fingers 26 and 28 rotate in counterrotation to intermediate finger 30 so that the fingers intermesh. Intermediate finger 30 rotates about a pivot axis and center 32 while fingers 26 and 28 rotate about a center pivot axis 34 laterally offset with respect to center 32 but in the same horizontal plane.

Drive means is provided for rotating the fingers in the form of a motor 36 having a housing 38. The rotor of the motor is mounted on a shaft 40 and the stator of the motor is centered in the housing 38. Mounted to the motor output shaft 40 is a speed reducing means which provides a speed reduction and a torque multiplication factor of one hundred sixty (160). The speed reducer is preferably a Harmonic drive, model HDC-1M-160-2A, manufactured by the Harmonic Drive Division of U.S.M. Corporation, Wakefield, Massachusetts. The operating principle of the Harmonic drive is that it uses a rotating elliptical element to produce rhythmic deformation of a toothed elastic member reacting against a toothed reaction member. Differing tooth members on the meshing elements produce reduced output motion with corresponding multiplication of torque. Ratios between about sixty to one (60:1) and two hundred to one (200:1) can be achieved in a single pass with the Harmonic drive.

Finger 30 is mounted along with a gear section 44 on a shaft 46. Motor 36, Harmonic speed reducer 42, finger 30, gear section 44, and shaft 46, rotate about center 32. Gear section 44 meshes with a gear section 48 which is attached to fingers 26 and 28 to

rotate these fingers in counterrotation to finger 30.

Retainer means for retaining handle 18 in a latched position in the end effector device is provided by latch means incorporated into face plates 22 and 24 which include latches 50 which rotate about centers 52. Latches 50 serve to retain the telescope handles in a retainer recess 54. The telescope handle or other object is held firmly against the latches 50 by a spring-loaded pad 56. Means for actuating the latches 50 is provided whereby the latches are retracted to release the telescope handle by movement of fingers 26, 28, and 30 to a full open position. In the full open position, the fingers contact and rotate cams 57, only one of which may be seen in the cut away view of Figure 2. However, it is to be understood that a second cam is located in a corresponding location to be contacted by intermediate finger 30. Rotation of cams 57 retracts latches 50 by link means in the form of linkage arms 58 pivotally connected to latches 50 and cams 57. The latches are held or locked in the deployed position against stops 60 by means of torsion springs 62 within cams 57.

The face plate and finger assembly is mounted to a base 64 by a pivot pin 66. This pivotal mount allows the face plate and finger assembly to cock a prescribed number of degrees, preferably plus or minus five (5) degrees, until abutment shoulder surfaces 68 are reached. A leaf spring 70 is attached to pivot pin 66 and is retained in base 64 by pins 72. The leaf spring provides centering of the face plate and finger assembly.

In operation, in order to affect docking of the orbital maneuvering vehicle 10 with the handles 18 of the space telescope 12, the orbital maneuvering vehicle approaches the space telescope until the handles are within the capture envelope 74 defined by surfaces 76 and 78 formed in the face plates 22 and 24 which act as means for guiding handle 18 into recess

54. The L-shaped fingers 26, 28 and 30 are activated at this time trapping the handle and forcing the handle into recess 54. Initially, the fingers are pivoted to a completely open position wherein finger bases 30a, 26a, 28a are generally horizontal. The guide surfaces 76,78 are entirely clear for guiding handle 18 into the "V" 74 whereupon the fingers counterrotate to pull the handles into recess 54.

As the fingers move in counterrotation, the face plate and finger assembly may cock about pivot 66 to allow the handle to fully enter recess 54 and engage all four latches 50. When fully received in recess 54, the handle of the space telescope will engage and depress spring-loaded pad 56 and be resiliently retained in recess 54. The handle will bottom out on face plates 22 and 24.

Current to motor 36 will rise and the motor will be cut off by a current limiting switch. At this point, the fingers 26, 28, and 30 may be backed off and the telescope handles will be retained against latches 50 by spring-loaded pad 56. This prevents the telescope handling loads from being imparted on the drive mechanism.

When the telescope handles are to be released, fingers 26, 28, and 30 are moved to the full open position. In this position, the fingers actuate cams 57 which retract latches 50 by way of links 58 and free the telescope handles or other object being gripped. When cams 57 have moved through full travel, the motor current will again rise and the motor will be cut off by conventional current limiting switch.

While a preferred embodiment of the invention has been described using specific terms, such description is for illustrative purposes only, and it is to be understood that changes and variations may be made without departing from the spirit or scope of the following claims.

Abstract of the Disclosure

An end effector device (A) for grasping and holding an article such as a handle (18) of a space telescope is disclosed. The device includes a V-shaped capture window (74) defined as inclined surfaces (76, 78) in parallel face plates (22, 24) which converge toward a retainer recess (54) in which the handle is retained. A pivotal finger (30) meshes with a pair of pivoted fingers (26, 28) which rotate in counterrotation. The fingers rotate to pull a handle within the capture window into recess (54) where latches (50) lock handle (18) in the recess. To align the capture window, plates (22, 24) may be cocked plus or minus five degrees on base (64).