

N87-20324

# CALPOLY SPACE PROJECT

---

G-279

by

David R. Farley

## **ABSTRACT**

The Cal Poly Space Project is an effort on the part of several highly motivated students to deploy a space canister which will examine the effects of microgravity on electroplating and immiscible metals. The experiments will be controlled and monitored by a specialized triple redundancy system developed to defer the possible electronic errors due to uncontrollable factors such as photons from the sun. With the finalization of the payload design and the near completion of the data control system, the integration phase of the project is anticipated to be completed and the project ready for launching by early 1987. It is hoped that our experiments will lead to new insights in space research and also prove profitable to industry alike.

## **Introduction**

At California Polytechnic State University, San Luis Obispo, we are taught to "Learn by Doing." Our 2.5 cubic foot canister was donated by Robert Mager in hopes that Cal Poly students could gain scientific knowledge and information along with invaluable career experience.

For the past seven years students from a variety of fields have worked and learned collectively to make the Cal Poly Space Project a reality. Among these contributions are many university required senior projects, which ranged from a financial report and budget to stress analysis testing. Since the program is coordinated completely by students, the experience has been uniquely rewarding as well as preparation for entering our respective professions.

## **Electroplating**

In microgravity many things can be done more easily and efficiently. Our electroplating experiment examines the effect of microgravity to produce a more uniform and higher quality plating. We will run sixteen separate cells, each utilizing differing agitation rates and type of plating (nickel or composite). In addition, the cathodes of the cells will have different shapes to determine if odd shapes promote a lesser quality plating. Small electronic components will be nickel plated and bearing steels will be plated with a tungsten carbide composite by the codeposition process. Codeposition involves suspending tungsten carbide particles in the electrolyte that become embedded in the plating to produce a hard, corrosion-resistant surface.

## **Immiscible Alloys**

Our other experiment will produce an alloy from immiscible metals that would be extremely difficult to accomplish on earth. After being melted and combined, the effect of microgravity should allow the metals to solidify without separating. The two furnaces used for the immiscible alloys experiment were designed and built by the Space Payloads Group in exchange for 22 furnace body shells manufactured at Cal Poly. When the samples have returned to earth they will be analyzed by photomicrographs, X-Ray diffraction, and a measurement of the superconducting transition temperature and critical field.

ORIGINAL PAGE IS  
OF POOR QUALITY

CAL POLY SPACE PROJECT	
FURNACE MOUNT LAYOUT	SCALE: 4X
DRAWN BY: ROB KNESTRICK, P.TEMP	UNLESS NOTED DIMENSIONS ARE IN INCHES. TOLERANCES .XX± .XXX±
DATE: 11-25-85 UPDATED 3-6-86.	

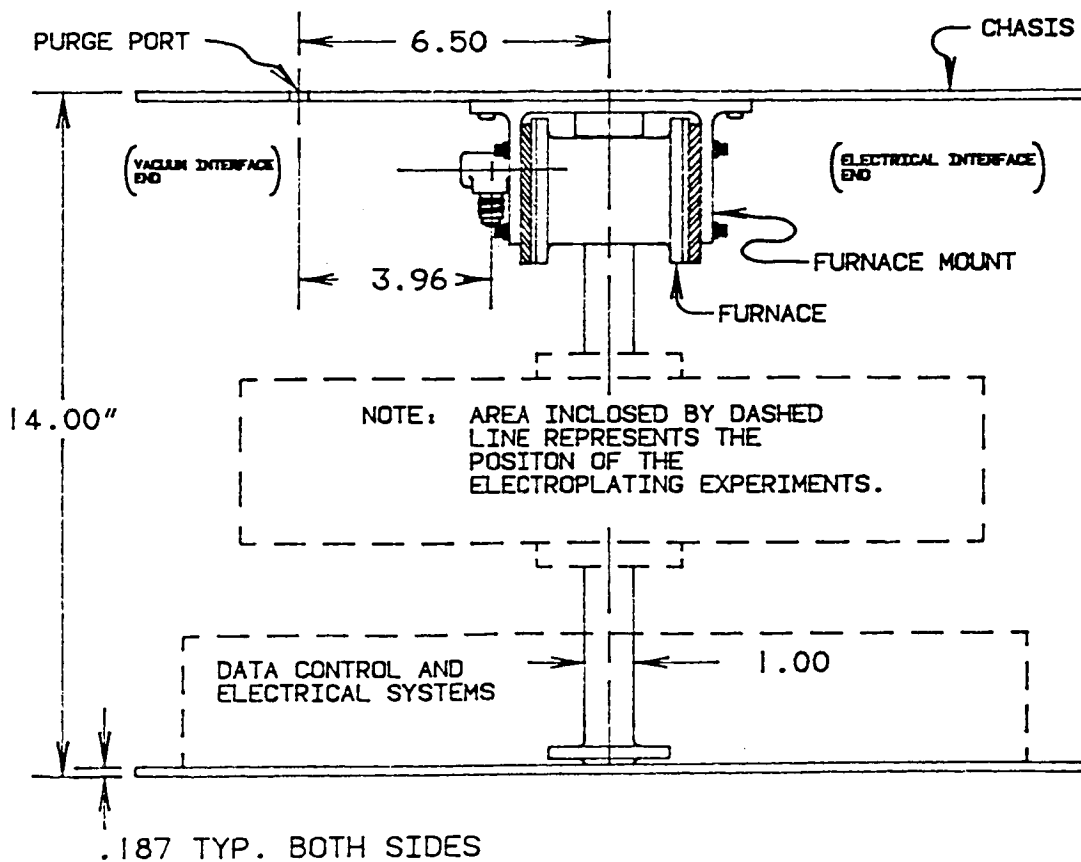

ORIGINAL PAGE IS  
OF POOR QUALITY

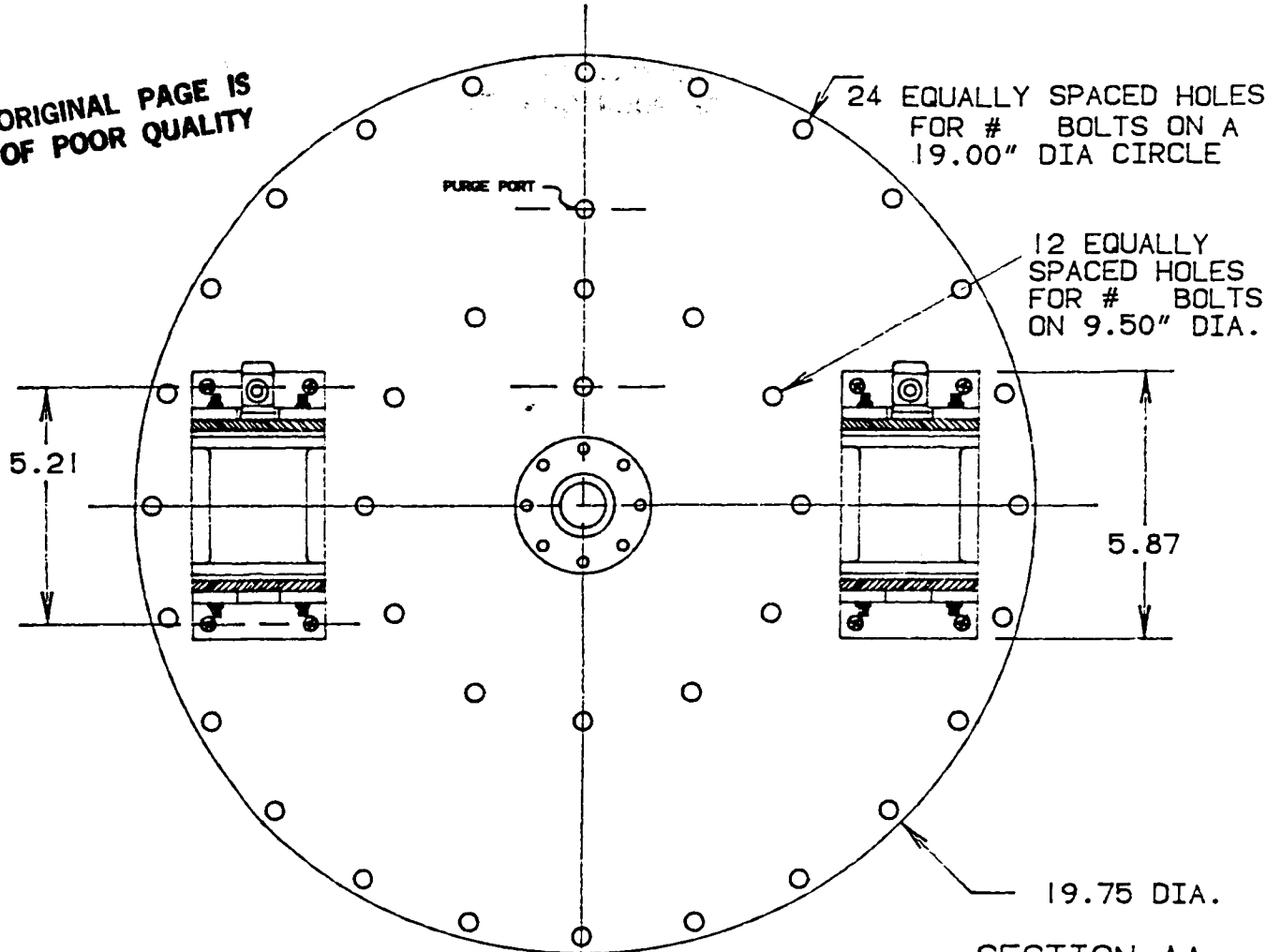

SECTION AA

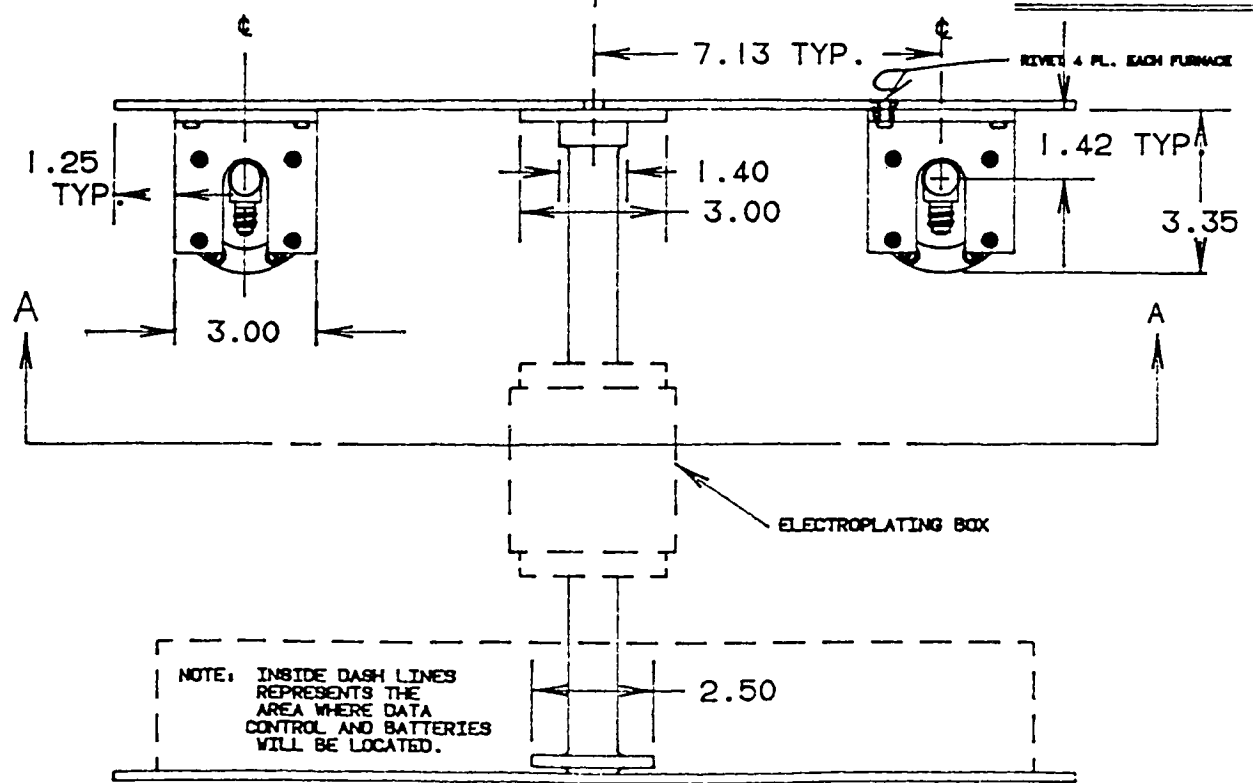

ORIGINAL PAGE IS  
OF POOR QUALITY

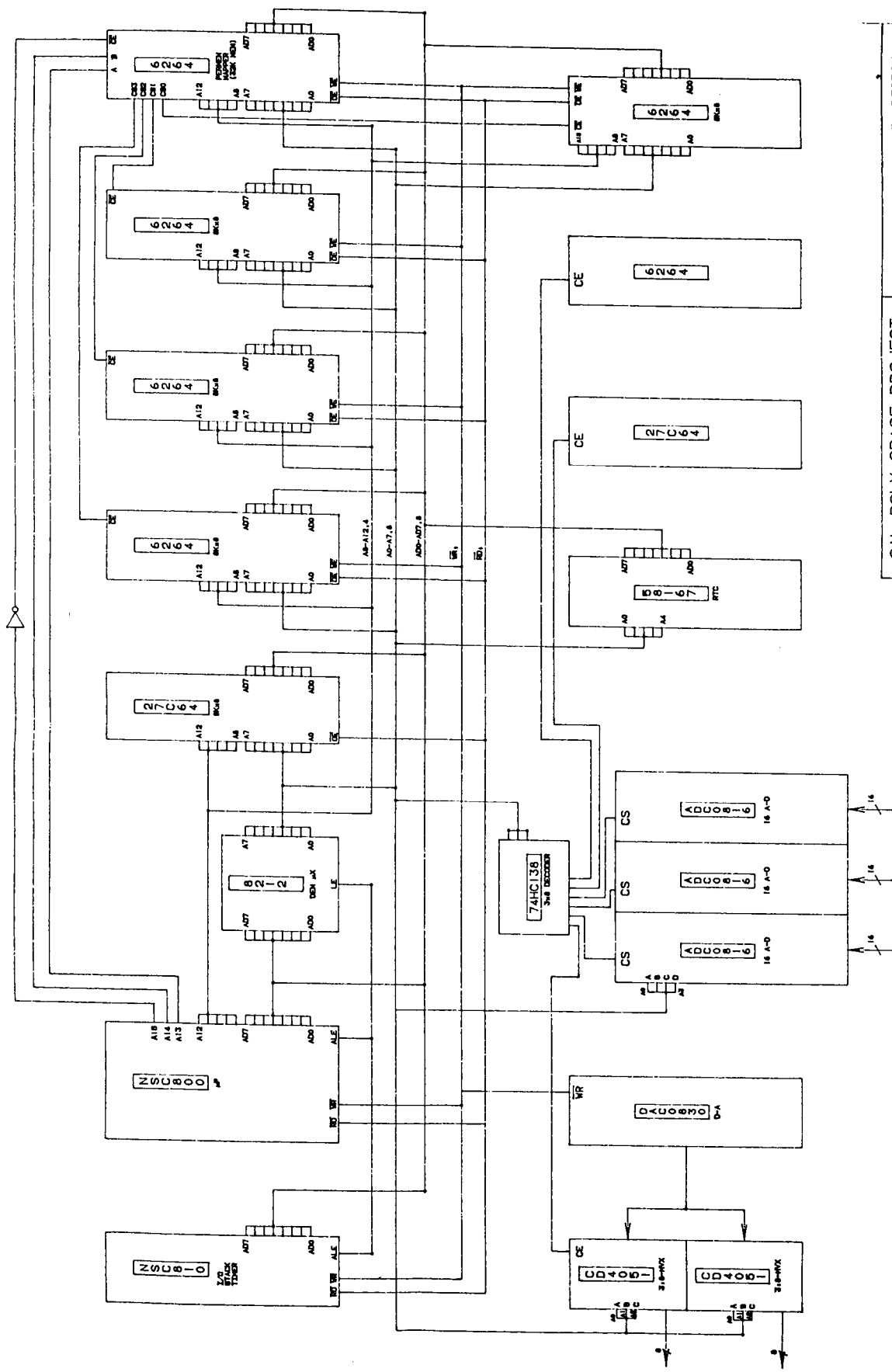

CAL POLY SPACE PROJECT DATA CONTROL - LOGIC DESIGN  
 DRAWN BY: THOM MAGNUM, P TEMPLIN DRAWING # C-279-8  
 SCALE: NOT TO SCALE DATE: 4-22-1986

## **Data Collection and Control**

Reliability is our main concern with the data collection system. We will be using a specialized triple-redundancy approach which should defer any unanticipated hazards. Data collection and control is comprised of a microprocessor with a real time clock, which will count levels of power, temperature, rates and time operations. The system uses an analog to digital converter, a digital to analog converter, EPROM to store the program, and RAM to store the data. A "Watchdog" ROM chip will decide if the primary microprocessor is performing correctly. If the primary microprocessor is inaccurate, then full control of the experiments is transferred to the secondary processor, and finally a third processor would gain control if the second malfunctions. These precautions should provide ample reliability for our experiments.

## **Chassis**

The Aluminum chassis has a modified cantilever structure which has been designed, built, and tested. All experiments and support systems shall be connected to a central vertical pole which will save space as well as keep the components securely in place. Vibrational and stress analyses were performed on an identical test structure. The chassis was found to have a fundamental frequency of 80 Hz.

## **Conclusion**

We will be conducting our test analysis of the entire project as soon as all the components are completed and integrated. By the time the Space Transportation System is again operational, our project shall be ready. A few selected members of our group will transport the project to Kennedy Space Center and also witness the launching of the Space Shuttle. After retrieving the canister, an examination of the products and recorded data will enable us to discover exactly what occurred during each experiment.

Possibilities of a future project are already being considered. The experience gained from our first project will be extremely advantageous to us for a more productive and timely second project. As a result of the Cal Poly Space Project, our members feel confident of their abilities and are also prepared for their futures.