

**N87-20330**

G-300, THE FIRST FRENCH GETAWAY SPECIAL  
MICROGRAVITY MEASUREMENTS OF FLUID THERMAL CONDUCTIVITY

J.C. PERRON, P. CHRETIEN, C. GARNIER and N. LECAUDE

Laboratoire de Génie Electrique de Paris - E.S.E  
Plateau du Moulon - 91190 Gif-sur-Yvette - France -

### Abstract

On earth thermal conductivity measurements on liquids are difficult to perform because thermal motions due to convection. In microgravity the convection due to buoyancy is evanescent and we expect a strong lowering of Rayleigh and Nusselt numbers. Three low viscosity liquids are selected to carry out the measurements : distilled water (standard) and two silicone oils. We use a modified "hot plate" method with a simplified guard ring, the lowering of convective motions let us to use in the experimental cells larger interplate distances and/or temperature differences than in earth measurements so the accuracy must be improved. Comparisons between earth and orbit results may help to understand the convection occurrence in our cells.

### Introduction

In 1979, with an advertising sake, Matra Company had reserved a Nasa Getaway Special (GAS) and organized a competition between French universities to promote space research. We won this challenge and so Matra gave us the opportunity to carry out our first experiment in microgravity. The objective of our payload is as follows. On earth the thermal conductivity measurements are difficult to perform on fluids because thermal motions due to convection. This later comes from the coupling between gravity field and temperature gradients in the experimental cell. In orbit if we assume a zero gravity, the convection due to buoyancy disappears and the accuracy on thermal conductivity will be improved specially with low viscosity liquids. The objective of G-300 is to perform such measurements on three liquids : distilled water (standard) and two silicone oils. In this paper we described the methodology of our instrumentation and the solutions we have found to fulfill the GAS requirements.

### Support Structure

To support our payload we use 32 from the 45 holes available on the Experiment Mounting Plate (EMP). As seen in the perspective view (Fig. 1), G-300 payload is cantilevered from EMP and consists of an intermediate plate and a

bottom plate separated by four U-shaped struts. The sockets of these struts are bolted at 90° intervals on the EMP and bottom plates and they are fastened to intermediate plate by brackets. The bottom plate is supported laterally by four adjustable bumpers covered with Viton, these later have the same curvature as the inner canister wall and can be pressed against it. The battery box is located between EMP and intermediate plate and bolted to them. The electronic rack is positioned between intermediate and bottom plates and secured to them. The experiment items consist of three tandems each including two cells. Each cell is mounted on an aluminium alloy support bolted to EMP and fastened to intermediate plate via a fiberglass plate (see photograph below). The design philosophy used in this payload has been to perform a good thermal path between experiment cells and the EMP to obtain a heat sink that evacuates the energy provided by heaters. A passive thermal control is sufficient in our case. The thermal paths of the various cells are decoupled at maximum taken into account the mechanical stiffness. The structure configuration provides a center of mass relatively closed to the EMP. The mass distribution is approximately as follows :

- |   |       |
|---|-------|
| . Support structure items               | 16 kg |
| . Battery box (filled)                  | 30 kg |
| . Electronic rack (filled)              | 6 kg  |
| . Experimental cells and their supports | 25 kg |

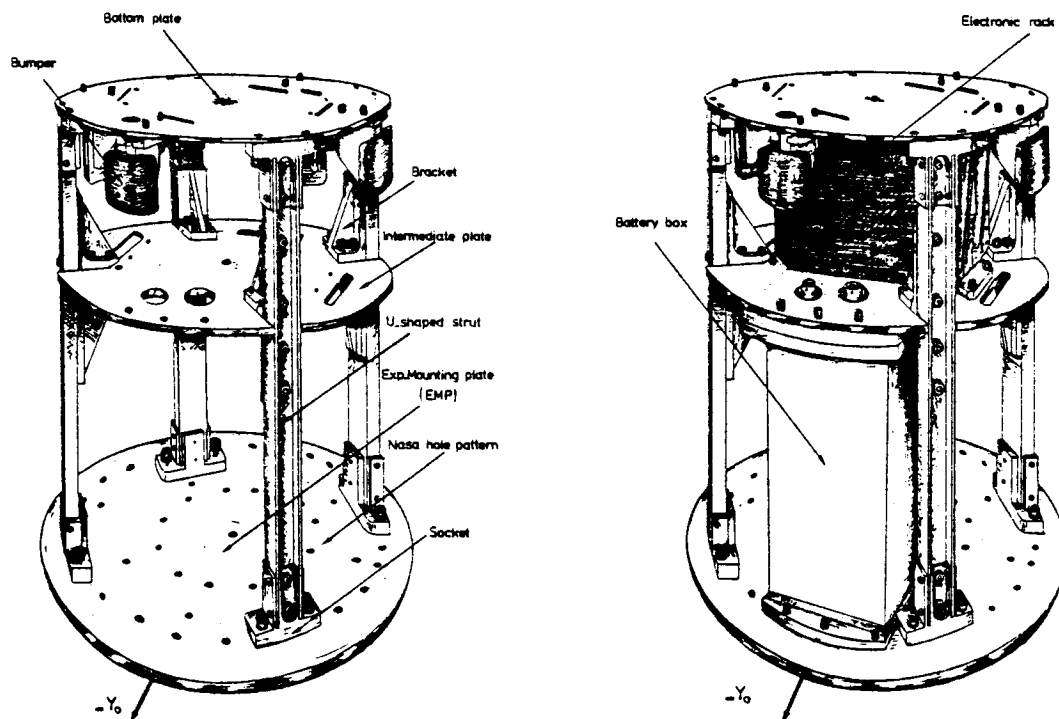

Fig. 1.G-300 Payload structure

## Measurement cells - Theoretical aspects

To carry out our experiments we have studied and manufactured a set of liquid containers adapted to thermal conductivity measurements. The cells are assembled in three tandems and each of them includes two cells filled with the same liquid. One tandem is filled with distilled water and the others with two silicone oils having a different viscosity. The shape of all tandems and cells are the same but in a tandem the two cells differ by the liquid thickness, this later varies from 2 to 5 mm. To avoid some corrosion of cells by the tested liquids (mainly distilled water) the inside part of the six cells are anodized after machining. Long duration tests (several months) are demonstrated the effectiveness of such a protection. Figure 2 shows the details of a tandem. The heater is a circular alumina plate covered with two silver contacts, a resistive path and a vitreous enamel (thick film technology). Two copper wires are soldered to silver contacts to power the heater (maximum current 0.5 A). The heater is stuck to the fiberglass cover with a glue giving a good mechanical strength in the expected temperature range - 20/+70°C. The liquid is in direct contact with the heater except for distilled water where a thin layer of silicone varnish is deposited on. In the center of the alumina heater and opposite to the liquid a thermocouple (TC) is stuck with conductive epoxy, its small wires (0.1 mm) are directed through the fiberglass cover by a small bore in which they are stuck. Six other thermocouples are glued on the fiberglass cover. Two other thermocouples are fixed in the body of cell machined with aluminium alloy. Above the heater a platinum resistance temperature detector (RTD) is glued to fiberglass cover. The RTD corresponding to a tandem are positioned face to face and wired as two branches of a bridge. The unbalance of this bridge provides an error signal needed to adjust the electrical power injected to one heater (slave) whereas the other is kept constant (master). This servo-controlled power supply provides a near zero temperature gradient between the two fiberglass covers so thermal losses are minimized. From the thermocouple voltages and with the measured electrical power, the thermal conductivity of liquid can be calculated. The cells are bolted to the cell stands which are attached by three bolts to the EMP. The two cells forming a tandem are joined by a lexan tube bolted to the cells. On each cell the two filling ports are opposite, one of them includes an expansion tube needed to accommodate the variations with temperature of the liquid volume.

They are usually three modes of heat transfer in liquids : conduction, radiation and convection. These modes are inherently linked in the one-G environment of earth and it is empirically difficult to separate their individual contribution. The convective effects may be determined by comparing the results of the experiments performed in space and on earth. Furthermore the space measurements may provide more accurate results if the convection is negligible. Various experimental techniques are used to obtain the thermal conductivity of liquids (Tsederberg, 1965). We have chosen a modified "hot plate" method with a simple guard ring to reduce heat losses above heaters. On the theoretical point of view the analysis of heat transfer is essentially different in the case of static liquid or when motions occur.

If the convection is negligible we may find the temperature field in our cell by two methods.

The first is an analytic one and starts from classical heat equation with idealized conditions along the limiting surfaces of liquid. The second one is a relaxation method. We have attached several thermocouples in our experimental cell (Fig. 2) from their signals we may calculate the temperature field anywhere in the liquid and by integration the heat flux. This last method is more realistic than

the former one but rests on experimental values.

If convection is present the thermal conductivity values increase (Fritz and Poltz, 1962 ; Poltz and Jugel, 1967) and calculations are more difficult. Usually to observe the convection phenomena the Rayleigh-Benard set-up is used, the liquid is placed between two isothermal planes and heated from below and convection occurs when the Rayleigh number reaches 1700. Our cell geometry is very different, firstly the heat comes from above the liquid layer and secondly the heater has a limited area so the convection occurrence is more difficult to estimate. As the temperature difference increases small liquid motions must take place near the heater limits and progressively these motions fill the whole layer. It seems that the transition to convection is smoother than in Rayleigh case and the critical value appears smaller (~ 700). A more detailed analysis will be performed to clear this aspect.

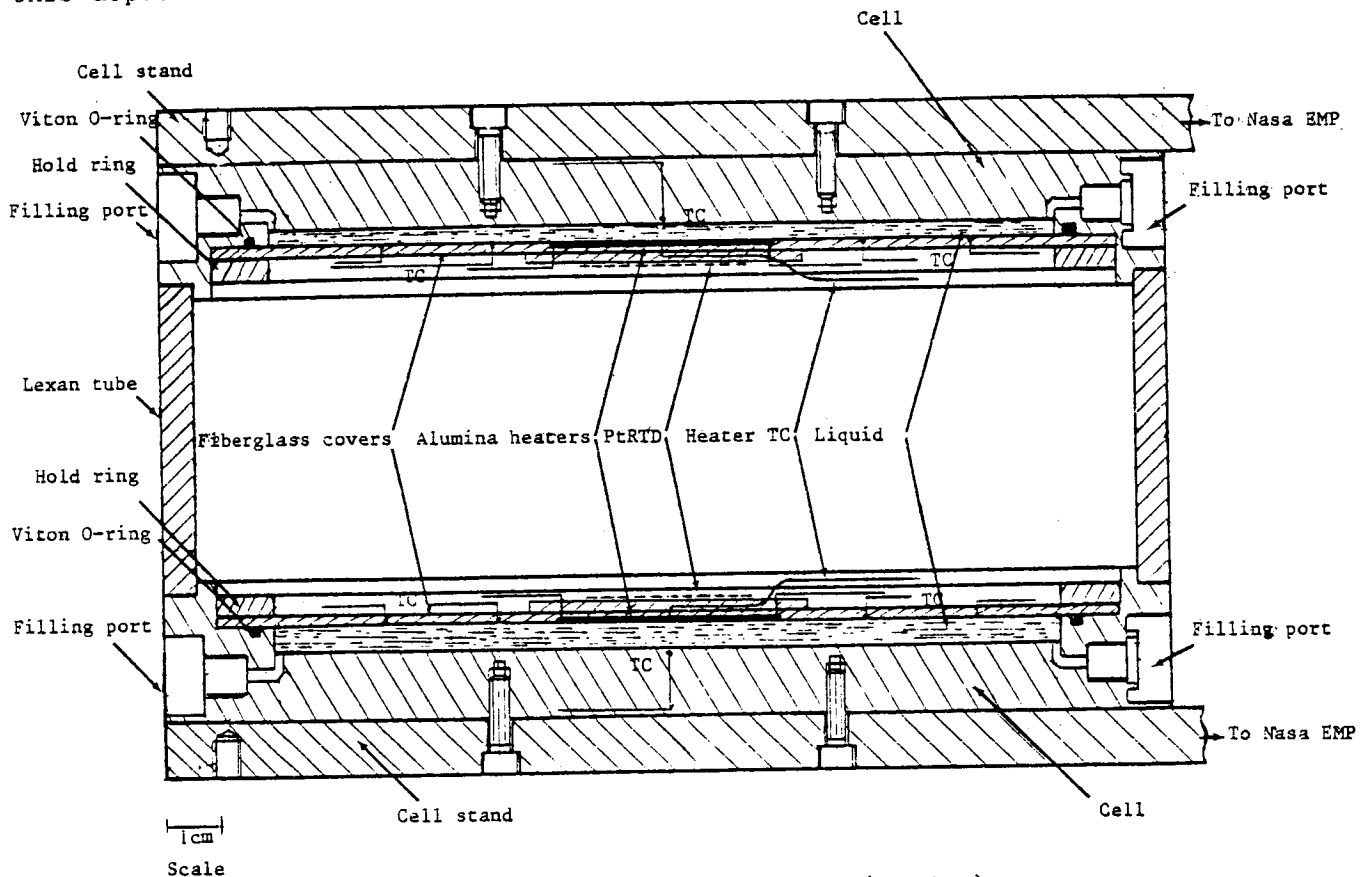

Fig. 2. Two measurement cells (Tandem)

### Power supply

Our payload is powered by only one battery. We have selected silver-zinc cells because their good charge retention and their reliability. The electrical energy to perform our experiments must be sufficient to power both electronic cards and cell heaters (only one tandem works at a time). The battery consists of twenty Ag-Zn cells joined together in two stacks of ten cells each so the power connector provides  $\pm 15$  V respect to ground (junction of stacks). The cell capacity is 40 Ah and the stored energy reaches 1200 Wh. The battery housing is manufactured with aluminium alloy and must be gas tight because  $H_2$  production (zinc corrosion) along standby. Furthermore this box is connected to the outside

of canister by two differential pressure relief valves provided by Nasa. Two connectors are fixed on the box cover, one of them delivers power and the other is used both to control each cell voltages at KSC integration and to transmit the battery temperature (two thermistors located in the housing). The experiment heaters are powered from the battery output via the servo-control card (see below) whereas the electronic cards are fed from a switching power supply giving regulated voltages (+ 5 V,  $\pm$  15 V). Along the mission the expected currents are relatively low (max. 1 A, mean 0.4 A) but the total experiment duration is long due to the thermal time constants of measurement cells. The available energy is large enough to power our payload along 60 h at minimum. The battery output ( $\pm$  15 V) is controlled (on/off) by the payload power contactor (PPC) located in the GAS interface and switched by astronaut. Two malfunction inputs are directed from our electronic rack to the Nasa PPC and if anyone is activated the power is interrupted, they are :

- . Overtemperature of battery housing, more than 70°C (Thermistor controlled)
- . Undervoltage of any battery stack, less than 12 V.

### Electronics

When the power is switch on the microcontroller start the experiments, collect the data and store it for use back on earth. The design of this control system must take into account reliability, power consumption, weight and compactness. We have studied and manufactured seven dual-sided PC Boards located in an electronic rack and using CMOS integrated circuits. Industrial grade components are soldered on the spare cards and military grade ones on the flight cards. Though the industrial temperature range - 25/+ 85°C will be adequate in the expected GAS thermal environment (see below) the military components give a better margin of safety. Figure 3 gives the system block diagram and the electronic cards are as follows :

- . CPU/ADC/MEM PC board includes the microprocessor NSC 800, I/O ports and timers, the monitor ROM (8 kbytes), a buffer RAM (8 kbytes), two independent memories used to store the data (EPROM 64 kbytes), the ADC (12-bit word format) and a RS 232 interface. The quartz frequency is 204.8 kHz.

- . Three low level cards amplify the thermocouple and RTD signals issued from each experiment tandem.

- . High level card (or housekeeping card) monitors the temperature in various locations of the payload (Thermistors) and checks the voltage of the battery and its temperature. If a problem occurs the malfunction input is activated via a non-maskable interrupt of microprocessor.

- . The servo-power PC board controls and provides the programmed powers to the master and slave heaters of the working tandem. Heater currents are fused and measured on this card.

- . The power/interface board houses the DC/DC converter giving from the battery output the regulated voltages (+ 5 V,  $\pm$  15 V) needed for electronic components. An output connector from this card is used to conduct the malfunction signals to Nasa PPC and the RS 232 bus to outside the GAS canister. This bus is used both for test purpose and to retrieve the data from EPROM.

### Operational scenario and software

The G-300 payload requires a minimum duration of two and half days and a "turn-on" signal for the experimental package as early in the Shuttle mission as possible to get satisfactory thermal environment (see below). When the power is delivered the microprocessor ( $\mu$ P) is reset and begins the monitor program stored on ROM. A twin-pack of cells is selected and a defined electrical power is supplied both to the master and slave heaters of this pack. The servo-system adjusts continuously the slave input to obtain a zero temperature gradient between the two fiberglass covers. The thermocouple voltages, the heater currents and the input connector temperature are measured and stored in RAM. Also a mean value of slave voltage is calculated and stored. The RAM values are stored in EPROM in two separate sequences via EPROM programmer. Each experiment duration is two hours at maximum, the stability of temperature gradient through the liquid layer or the elapsed time gives the end signal for this purpose. When it takes place the heater powers are switched off. Depending on the temperature of surrounding structure, a dead time may occur after which heater powers are injected on another twin. A timer is located on CPU card and time is read and stored at the beginning and the end of each experiment (2.8 s resolution). Sequentially the  $\mu$ P activates the three packs following the monitor program and the measurements are stopped when the elapsed time is about 60 hours.

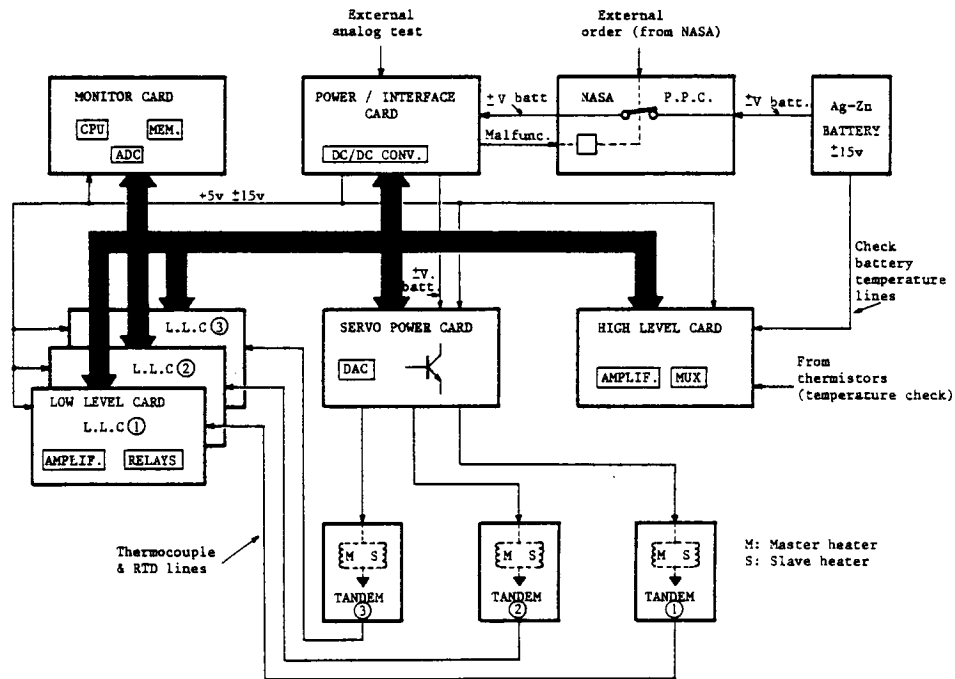

Fig. 3. System block diagram

The program is written with Z-80 assembler language. It includes various subroutines and mainly one called each three minutes to perform the temperature measurements on the working tandem. The power servo-control has a time cycle of 2.8 s and adjust continuously the slave heater. These two functions are the primary activities of the microcontroller system and their clock rates have been selected by taking into account the thermal time constants of experimental cells. The program also checks and stores the initial thermal conditions of the whole payload and of the selected tandem at the beginning of each experiment before to apply the power. In a reliability sake we have planned to add some "watch dog" instructions to the program.

## Thermal design

Along thermal measurements one important point is the internal temperature value and its stability with time. In a GAS environment it is difficult to obtain long term stability as the Shuttle changes its orientation relative to the sun and the dark sky. Fortunately the canister is well insulated laterally and as we have chosen an insulated top cover with a silverized teflon exterior coating and although the external parts of the container experience wide excursions in temperature, the internal temperatures remain relatively stable. This experimental result was obtained from the analysis of data collected with the Nasa Verification Payload which flight aboard of STS-3 mission (Butler, 1983). From these results we have try to use a simple thermal model for our payload. If we except the case where the Shuttle bay is steadily oriented to the sun and if we take into account the low dissipated power of our payload (close to 10W) we find that the internal temperature is always decreasing with elapsed time. As we measure the thermal conductivity of water (as a standard) we must keep positive temperatures along the experiment duration. We may conclude that this objective is reach with two Shuttle attitudes : bay/earth or passive thermal control (slow rotation along X axis). The importance of the "on" delay in orbit must be emphasized because we benefit from the thermal inertia of the payload.

## Testing

A finite element stress analysis of the structure was performed by using NASTRAN program. No resonance frequency below 35 Hz was detected. A serie of environmental tests were performed at Intespace facilities in the end of 1985. They have been conducted on the whole payload secured in a canister similar to the Nasa one. The thermal tests were carried out in a thermal chamber filled with dry N<sub>2</sub> gas. The temperature was changed up and down from 20°C to 70°C and was cycled from 20°C to - 20°C. The system works correctly in this temperature range. The first vibration tests were performed by using along the three axis sinus vibrations from 5 Hz to 2 kHz (sweep speed 2 oct/mn) with a 0.3 g level. No resonance frequency below 35 Hz was detected. The second tests were carried out by using the Nasa qualification spectra (Nasa, 1984). In this case the vibrations were random with an overall r.m.s. level of 13 g (20 Hz - 2 kHz) and the test duration is specified at 40 s per axis. These tests have proved that the mechanical stiffness of our payload is sufficient and fulfills the Nasa requirements-EMI tests were performed on payload without canister to satisfy Nasa requirements to radiation emission in narrow and broad bands. These measurements were conducted in an anechoic chamber in the frequency range 10 kHz - 10 GHz. The emission level was always below the specifications. To check the ability of G-300 payload in the canister to work correctly in the Shuttle environment we have carried out a radiation susceptibility test. The payload was never disturbed by external elctromagnetic fields simulating Shuttle activities.

## Conclusion

G-300 payload is completed and works correctly and environmental tests have demonstrated that it fulfills the Nasa requirements. The safety acceptance is in progress and the last vibration tests are scheduled on the flight model in the beginning of 1987. This payload is essentially the result of the work of paper coauthors and it represents their first step in space research.

ORIGINAL PAGE IS  
OF POOR QUALITY

Fig. 4. Photograph of G-300 payload  
after integration

- 1-Intermediate plate
- 2-Bottom plate
- 3-Experiment Mounting plate
- 4-U-shaped strut
- 5-Bumper
- 6-Battery box
- 7-Electronic rack
- 8-Tandem(two cells)
- 9-Cell support
- 10-Fiberglass stiffener

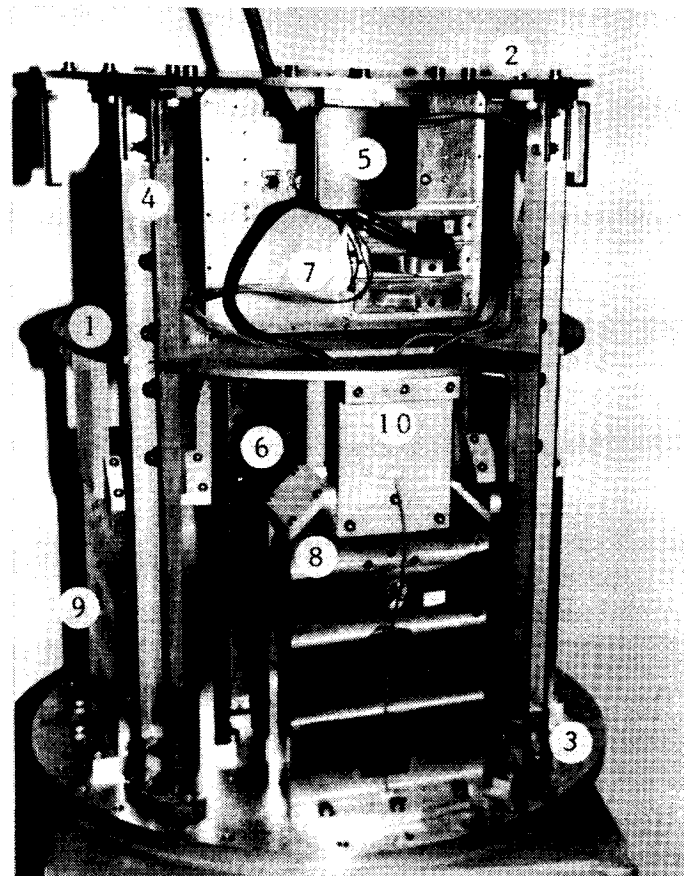

#### Acknowledgements

The authors would like to gratefully acknowledge :

The Matra Company for giving the opportunity to perform an experiment in microgravity conditions and to reserve a Nasa GAS for this purpose.

The CNES Administration of giving a contract without which this payload cannot be achieved and for providing access to Intespace facilities where the environmental tests were carried out.

Thanks are due to National Semiconductor and Analog Devices Companies for their generous gift of industrial and military grade components and to "Radio" departement of E.S.E. which has performed thick film depositions on heaters.

#### References

Butler, D. (1983). Getaway Special thermal design summary. Nasa Report. X-732-83-8.

Fritz, W., and H. Poltz (1962). Absolutbestimmung der Wärmeleitfähigkeit von Flüssigkeiten-I. Kritische Versuche an Einer Neuen Plattenapparatur. Int. J. Heat Mass Transfer, 5, 307-316.

Nasa (1984). Get Away Special (GAS). Experimenter Handbook.p. 57.

Poltz, H., and R. Jugel (1967). The thermal conductivity of liquids-IV. Temperature dependence of thermal conductivity. Int.J.Heat Mass Transfer, 10, 1075.

Tsederberg, N.V. (1965). In R.D. Cess (Ed.), Thermal conductivity of gases and liquids. M.I.T. Press, Cambridge (U.S.A.). Chap. 1, pp. 1-65.