

NASA Technical Memorandum 89072

**LARGE SPACE ANTENNAS
A SYSTEMS ANALYSIS
CASE HISTORY**

(NASA-TM-89072) LARGE SPACE ANTENNAS: A
SYSTEMS ANALYSIS CASE HISTORY (NASA) 19 p
CSCL 22B

N87-20352

63/18 Unclass
45377

February 1987

NASA

National Aeronautics and
Space Administration

Langley Research Center
Hampton, Virginia 23665-5225

NASA Technical Memorandum 89072

**LARGE SPACE ANTENNAS
A SYSTEMS ANALYSIS CASE HISTORY**

Compiled by

Lloyd S. Keafer
The Bionetics Corporation
Hampton, Virginia

and

U. M. Lovelace
Langley Research Center
Hampton, Virginia



National Aeronautics and
Space Administration

Langley Research Center
Hampton, Virginia 23665-5225

INTRODUCTION

The value of systems analysis and engineering is aptly demonstrated by the work on Large Space Antennas (LSA) by the NASA Langley Spacecraft Analysis Branch. This work was accomplished over the last half-decade by augmenting traditional system engineering, analysis, and conceptual design techniques with computer-aided engineering (CAE) techniques using the Langley-developed Interactive Design and Evaluation of Advanced Spacecraft (IDEAS) system. This report chronicles the research highlights and special systems analyses that focused the LSA work on deployable truss antennas. It notes developmental trends toward greater use of truss structures in other large space systems and toward greater use of CAE techniques in their design and analysis. A look to the future envisions the application of improved systems analysis capabilities to advanced space systems such as an advanced technology space station or to lunar and Martian missions and human habitats.

HISTORICAL BACKGROUND

For decades, LaRC has been the lead Center for NASA in research on materials, structures, and controls. The application of lightweight composite materials to aeronautical systems was quickly followed by the development of composite material struts in various truss designs to form large lattice-type space structures. The further development and application of this new space structure technology was fostered under the LaRC-managed Large Space Structures (LSS) and Large Space Systems Technology (LSST) programs.

Significant changes in philosophy and emphasis occurred with the broadening of the program from structures only to systems technology. At the same time, the Shuttle was becoming a proven and usable system and computer-aided engineering was ushering in a new era of rapid interactive design and analysis of advanced space systems concepts. Proposed structures were extremely large and relatively flimsy and generated a new area of technological concern--that of control of flexible structures (COFS), which challenges both the available analytical methods and the systems engineers.

New dimensions were added when the LSST program chose as its focus Large Space Antennas (LSA)--dimensions such as large curved structures (dish) and

precision reflecting surfaces (radio frequency mesh) (r.f.). Also, packaging and stowage of the complete electromagnetic system in Shuttle and kinematics/kinetics, controls, and adjustments related to antenna deployment in space were new considerations.

But even with the LSA focus, the evolutionary path of large system development remained unfocused and requirements became nebulous. Temporarily, size considerations were reduced (because of antenna accuracy and Shuttle accommodation constraints), and new types of structures which had only limited applicability to other types of large space systems were seriously considered for antennas. For example, concepts primarily applicable to antennas included the Hoop Column (HC) antenna--a LaRC-sponsored development of a tension-stabilized mesh supporting structure, the Wrapped Radial Rib antenna--a JPL-sponsored development of a stowable curved cantilever mesh supporting structure, and various inflatable systems using metallized membrane reflectors. Furthermore, these concepts are exclusively deployable; i.e. not amenable to assembly, erection, or construction in space using stowed parts and materials.

In the evolutionary process, however, truss-type structures were thoroughly analyzed and have emerged as a competitive "species." They are competitive not only for deployable antennas, but also for broad application to a variety of beam, curved surface and platform-type structures, which can be designed for deployment or assembly or erection, or a combination thereof. So although the HC antenna or the radial rib antenna may be the first flown, truss structural concepts with their broad applicability are likely to eventually emerge as a preferred structural concept.

SPECIAL ANALYSES

It is informative to review the CAE-type analyses and the associated testing of large space deployable truss antennas performed by the Spacecraft Analysis Branch. These analyses and tests influenced the evolutionary path of the broad large space structures program just described and directly affected truss antenna development. These analyses and trade studies are constrained to the conceptual level of detail to allow a wide variety of choices to be

reviewed in an early comparative process. Although detailed design analyses are sometimes required, they are generally limited to that necessary to verify the conceptual trades or to answer specific questions resulting from the conceptual design comparisons. Five selected examples of analyses ranging from structural synthesis to complete system performance predictions are discussed in this section. Resulting research and developmental trends are discussed in the next section. Tetrahedral and box truss concepts are highlighted, but analyses of competing antenna concepts are also included.

Structural Synthesis and Analysis--The starting point is the synthesis via finite-element modeling of the antenna's basic structural support system and the associated mesh tie system. Interactive Design and Evaluation of Advanced Spacecraft (IDEAS) has an automated finite-element modeling capability using mathematical synthesization to rapidly generate dishes of any size, shape, and structural density for several classes of repeating structures. The structural classes (tetrahedral truss, box truss, hoop and column, and radial rib) are shown in figure 1. From designer inputs such as dish diameter, number of bays, number of ribs or cable/mesh segments, focal length over diameter, dish structural depth, material and section properties, and hinge and mesh masses, the synthesizers rapidly create the finite-element model and calculate the mass and inertial properties. The associated mesh-tie system is also synthesized. The inset illustrates the design for a typical tie system for one box truss section.

Once the antenna structural and mesh-tie model has been created, various types of structural analysis can be performed. Analyses range from examining the dynamic response to predicting the material strengths and element section properties necessary to maintain proper antenna shape under space operational conditions. The integrated data base of IDEAS allows the engineer to transfer the answers found by one analysis directly to subsequent analyses. For example, elemental temperatures obtained from a thermal analysis can be combined with other environmental loads to determine the stress and strain levels in each structural element of a complex antenna structure. This information can be used to examine the effects on antenna surface accuracy and to redesign elements which fail to meet the design requirements.

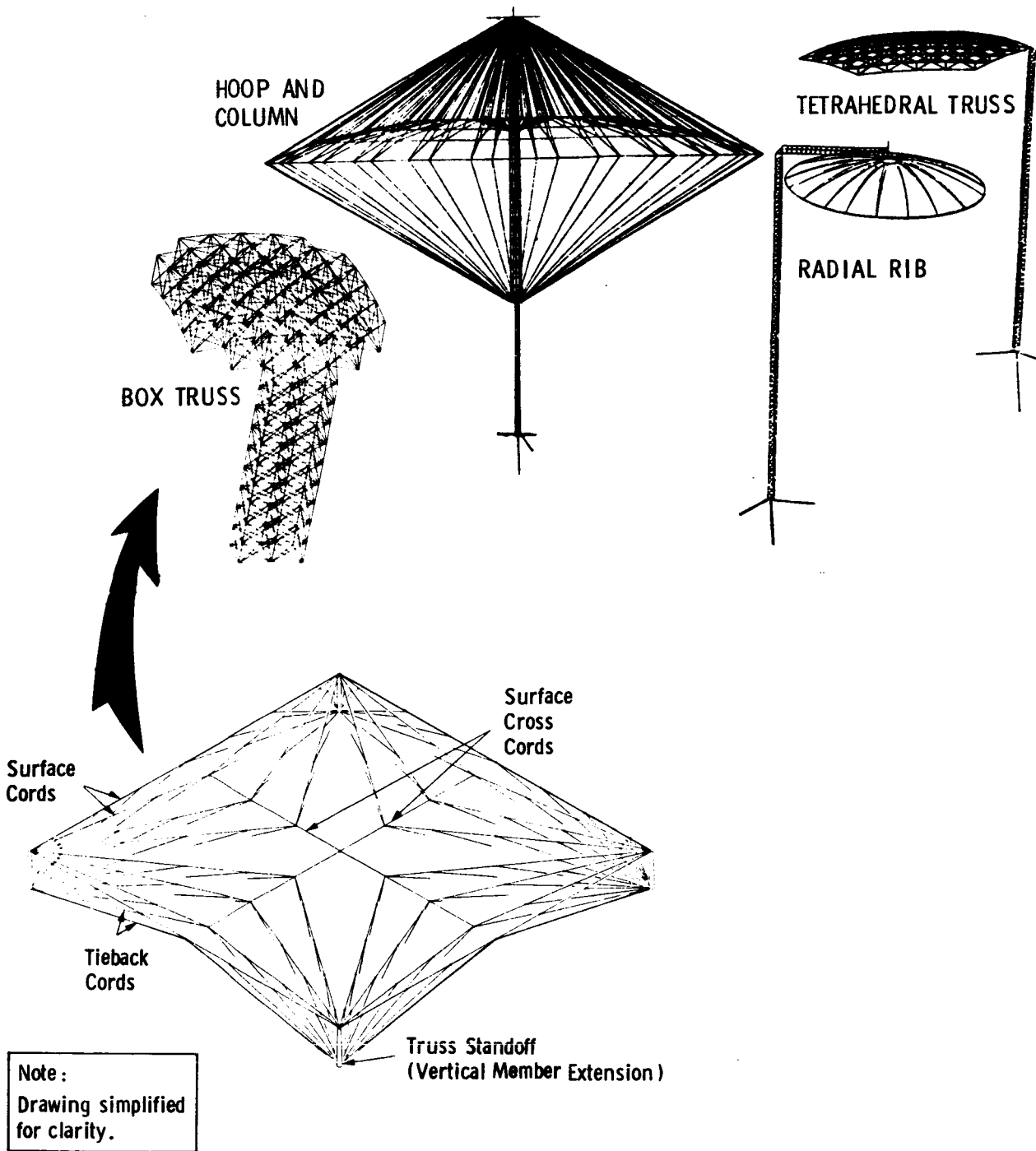

Figure 1. - Antenna structural concepts

type of information, the designer can quickly assess the impact on the antenna surface of such items as structural loading conditions (see the example in fig. 3), choices in materials and thermal coatings, or even changes in mission designs. Surface distortion results are illustrated in fig. 4. Once a structural design and a preliminary thermal design have been established, this analysis will help determine the worst case thermal conditions for subsequent detailed thermal analysis.

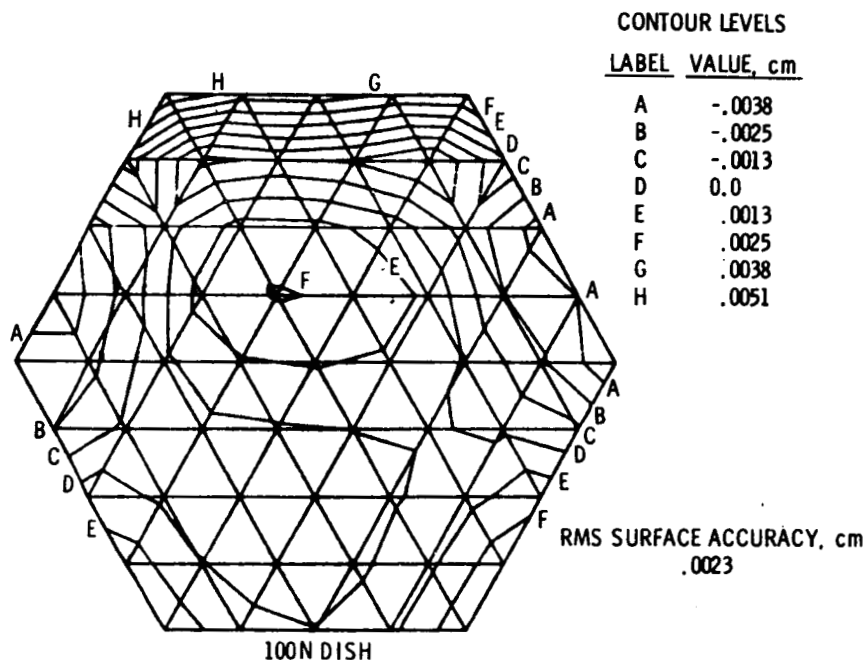

Figure 4. - Tetrahedral truss surface distortion

Deployment--Although large structural elements can be erected easily in space, assembly of the intricate mesh-tie systems in space will be much more difficult. Consequently, current large space antenna development will concentrate on preassembled and integrated mesh-tie and structural support systems. These can be packaged in the Shuttle and deployed in space with

minimum or no requirement for erection and assembly. Stowed configurations of antennas designed for the Land Mobile Satellite Service (LMSS) communications missions are shown in figure 5. Research has been devoted to kinematic and

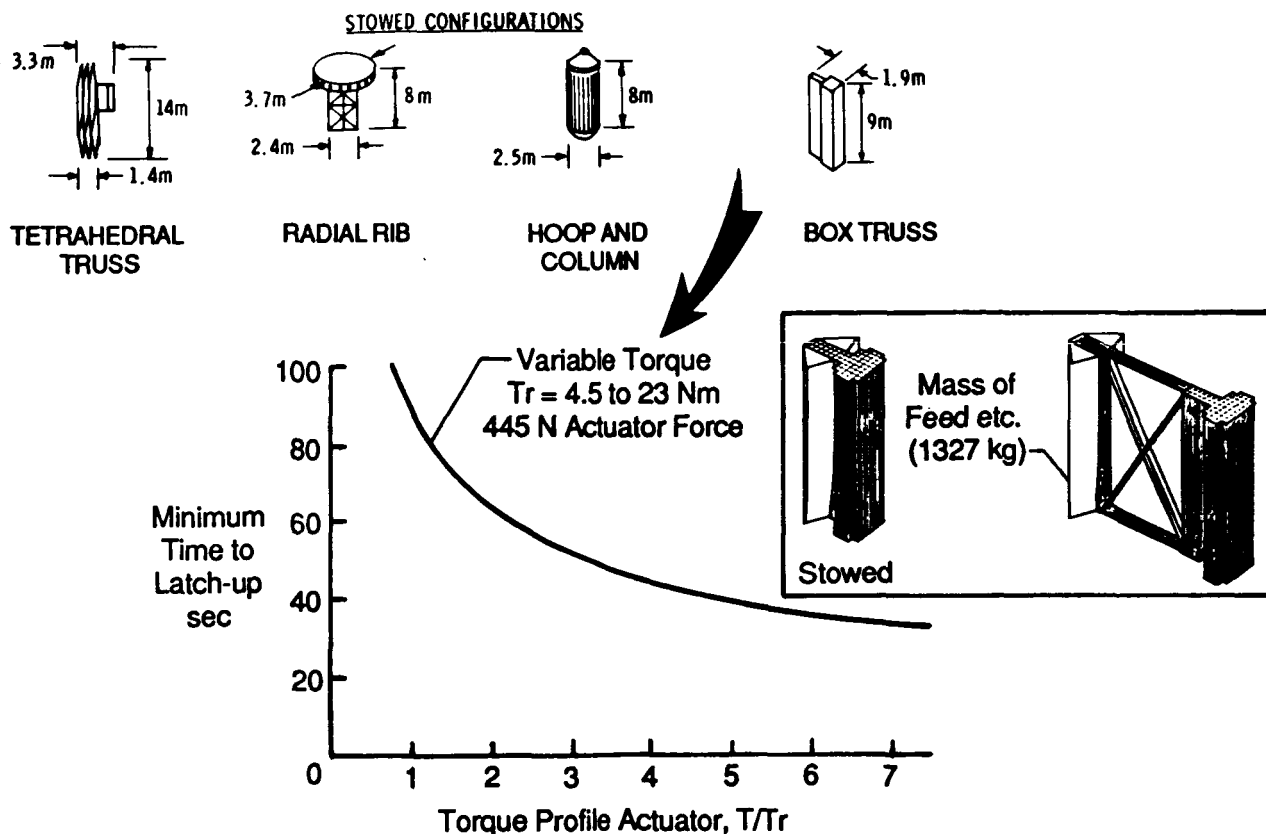

Figure 5. - Stowed configurations for LMSS antennas and deployment kinetics for the box truss design

kinetic analysis of the deployment of large antennas, because during antenna deployment, the host spacecraft undergoes large changes in center of gravity and inertia. Such changes may influence spacecraft stability and the control system design. Deployment kinetic data, possibly representative of sequential deployment of the box truss-type antenna, are shown in the inset. Deployment times are plotted as functions of the torque profile. The profile has a large ending torque to accomplish complete latch-up, including tightening of diagonal

members and the mesh. Deployment times for one double bay truss structure ranged from about 100 to 300 sec. Under such conditions, the box truss antenna shown in figure 1 would deploy in about 5 to 20 minutes. For the rapid simultaneously deploying structures, such as the tetrahedral truss, it is critical that the kinetic behavior be fully understood. Unbalanced deployment and high stress buildup in the structural members at latch-up can be major structural design drivers. Deployment induced vibrations may also lead to undesirable dynamic behavior of the spacecraft.

System Performance--A complete system performance analysis of the four antenna concepts for the LMSS mission was performed. It resulted in a comparison of the various features and attributes of this class of large space antennas.

Mass and structural data for the four structural designs are summarized in figure 6. The configurations and dimensions of the candidate structural elements are shown. The structural mass for these concepts represents one-

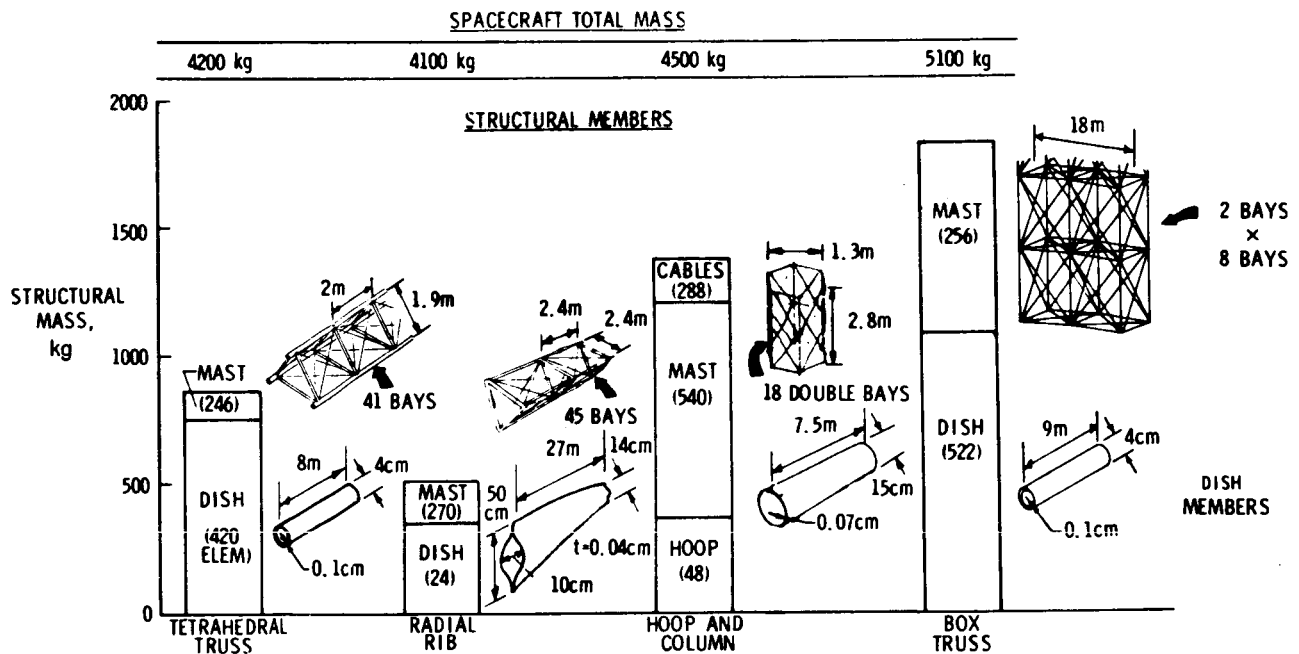

Figure 6. - LMSS mass and structural data

sixth to one-third the total spacecraft mass. Further reductions in structural mass are important, but for structural design considerations, strength, stiffness, and performance characteristics under environmental conditions (e.g., solar insolation) and operating loads (e.g., slewing) are more important. These affect the fine geometric accuracies required by LSA's. Mass, strength, and stiffness attributes along with deployment features are compared and ranked for the four concepts in the first four entries of table 1.

Table 1. Comparison and rankings of LMSS concepts

ATTRIBUTE	TETRAHEDRAL TRUSS	HOOP COLUMN	RADIAL RIB	BOX TRUSS
1. Mass	2	2	2	1
2. Structural Strength (1g, Launch, Orbit)	2	2	1	2
3. Structural Stiffness (Dish/Mast)	2/1	1/1	1/0	2/2
4. Deployment Ease	0	2	2	2
5. Dynamic Performance	1	2	0	2
6. Stability Figure Control	2	1	1	2
7. Mfg. Tolerances (Length/Rotation)	1/2	2/2	2/1	1/2
8. Part Count Complexity	1	1	2	1
9. Packaging Volume (Dish/Mast)	1/1	2/2	2/1	2/1
10. Subsystem Mounting Location	2	1	0	2
11. Universal Applicability of Structure	2	0	0	2
12. Figure Reshaping on Orbit	0	0	0	0
[Requirements Rank: 0 - Marginal, 1 - Meets, 2 - Exceeds]				

Dynamic response to anticipated LSA slewing maneuvers is summarized in Table 2 in terms of tolerances of four geometric deviations. Dimensional and dynamic stability of the feed-dish geometry, represented by tolerance limits for angular rocking and decenter, may be a potential problem for all but the box truss concept. Its stability is derived from the structural stiffness of its feed mast and its relatively high modal frequencies. The other antenna

concepts need to be redesigned to stiffen their feed masts. Dish surface shape and smoothness, represented by tolerance limits for defocus and roughness, stay within tolerance under slewing loads for three of the concepts. The radial rib concept requires some redesign. Any redesigns to meet dynamic response requirements will impose some mass penalty.

Table 2. Antenna concepts dynamic response performance

	ANGULAR ROCKING	DECENTER	DEFOCUS	SURFACE ROUGHNESS
Box Truss	2	2	2	2
Hoop Column	1	2	2	2
Tetrahedral Truss	1	0	2	2
Radial Rib	0	2	0	2
Tolerances: 0 - Outside, 1 - Within After Settling Time, 2 - Within During Maneuver				

The data on dynamic response to slewing maneuvers and other aspects of dynamic performance were compared and rated for the four concepts. These combined ratings are the fifth entry in Table 1. The results for seven other attributes complete the summary of the LMSS system performance. This comparative analysis indicates advantages for each antenna concept. The truss concepts, in particular, appear to have special advantages for precision antennas (e.g., attributes 3 and 6) and for large spacecraft systems (e.g., attributes 10 and 11). The "proof of the pudding" for antennas, however, is in the r.f. performance which results from accurate surface shape and smoothness and overall structural and mesh tie accuracy and dimensional stability (attributes 6 and 7). In this regard, the hoop column and truss concepts appear to rate extremely high. This is being verified currently by testing.

Model Test Performance--LSA models in the 5-m r.f. aperture class have been or are being built using the hoop column, tetrahedral truss, and box truss concepts. The first two have already been tested for deployment, reflecting surface shape and smoothness, and r.f. performance in the near-field test facility at Martin Marietta Aerospace Corporation, Denver, Colorado. The SAB analysis role in these model tests is to (1) guide the design and fabrication of a box truss model comparable to those concept models already tested,

(2) predict dish-feed geometry, dish surface smoothness and antenna r.f. performance, and compare each model's test data with its predicted results, and (3) analyze and evaluate the results of model tests of each LSA concept in terms of strengths and weaknesses of the design, requirements for flight testing, and operational potential. Some model test results and their significance in terms of developmental trends are given in the following section.

DEVELOPMENTAL TRENDS

Trends resulting from the analysis of LSA concepts are noted here by selected examples. Related trends for large space systems in general are noted also.

Stiffness and Controls--The most important result of recent analyses has been to show that several structural designs are feasible and practical for antennas in the 30 to 150-m size range. With proper feed mast design, these antenna structures will be stiff enough to provide the required dimensional and dynamic stability without the need for complex control systems, and the cost should be relatively low as shown in figure 7. This result should not blunt the "research" trend toward understanding the control of flexible structures. It should, however, make large space system designers and developmental managers more keenly aware of the practical "developmental" trend toward creating stiff truss-type structures in the several-hundred meter size class to avoid the complexity and cost of vibration control.

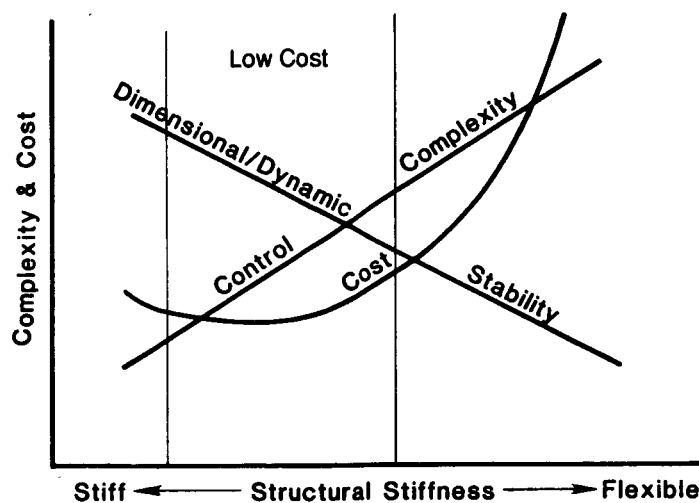
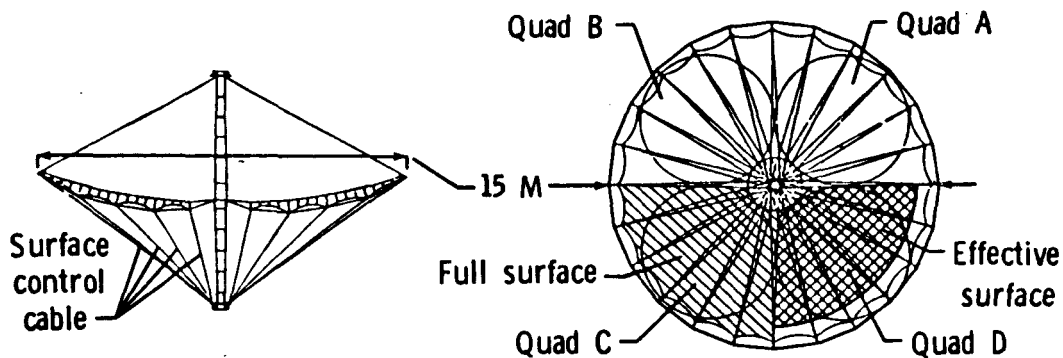

Figure 7. - Structural stiffness versus complexity and cost

Mesh Management and Modularity--The second most important result from recent analyses and model tests of the hoop column and tetrahedral truss concepts is that antenna dish surface and dish-feed geometric anomalies can be detected easily and their causes pinpointed. Furthermore, positioning the feed and practical adjustments in the mesh-tie system can be made in the lab, and possibly in flight, to correct these anomalies. For example, a new procedure for adjusting the hoop-column antenna is illustrated in figure 8 with data taken during the 15-m model near-field tests described earlier. This and similar procedures are being refined under a new Control Structures Electromagnetic Interaction program. A trend is developing from successful structural and mesh-tie adjustments (and from successful deployment tests) toward practical management of the delicate mesh reflector. If the trend being set by the box truss mesh-tie system toward individual box modularity continues, the door will be opened for putting LSA's in space by a combination of deployment, assembly, and erection as opposed to deployment only.



Quad	Original measured RMS		New predicted RMS		New measured RMS	
	Full Surface	Effective Surface	Full Surface	Effective Surface	Full Surface	Effective Surface
A	0.144	0.120	0.106	0.072	0.106	0.075
B	0.133	0.107	0.118	0.080	0.117	0.080
C	0.153	0.142	0.118	0.097	0.117	0.094
D	0.159	0.132	0.084	0.062	0.082	0.061

Figure is Courtesy of:
W.K. Belvin, SSD
LaRC

Figure 8. - New procedure for improving antenna surface accuracy

Deployment--Analyses and tests have shown that all of the various LSA concepts can be successfully deployed through many stow-deploy cycles while maintaining the structural integrity and accuracy. Analysis of the kinematics and kinetics of deployment continues. It shows slow, sequential, controlled deployment as the least stressing and most reliable approach (see fig. 5). The box type is currently the only truss structure that can be folded in two dimensions and then sequentially deployed.

Joint Freeplay and Manufacturing Tolerances--For the stiff truss structures, the worrisome problem of manufacturing tolerances and associated joint freeplay causing dimensional inaccuracy, vibration control, and element failure problems appears to be less severe than predicted earlier. Mode shapes, frequencies, and modal damping coefficients are sensitive to the amount of freeplay, and some freeplay may be required to permit smooth deployment. Knowledge of these freeplay sensitivities and requirements is needed to balance freeplay specifications, manufacturing tolerances, and production costs for good truss structure designs. SAB-sponsored analyses and tests on box truss structures indicate that tensioning diagonals (illustrated in fig. 9) are useful in controlling freeplay and in making the structure dynamically predictable. Indeed, the trend toward tensioning diagonals and dimensional adjustment techniques looks like it may solve the freeplay problem for many large space structures with only a small penalty in added complexity.

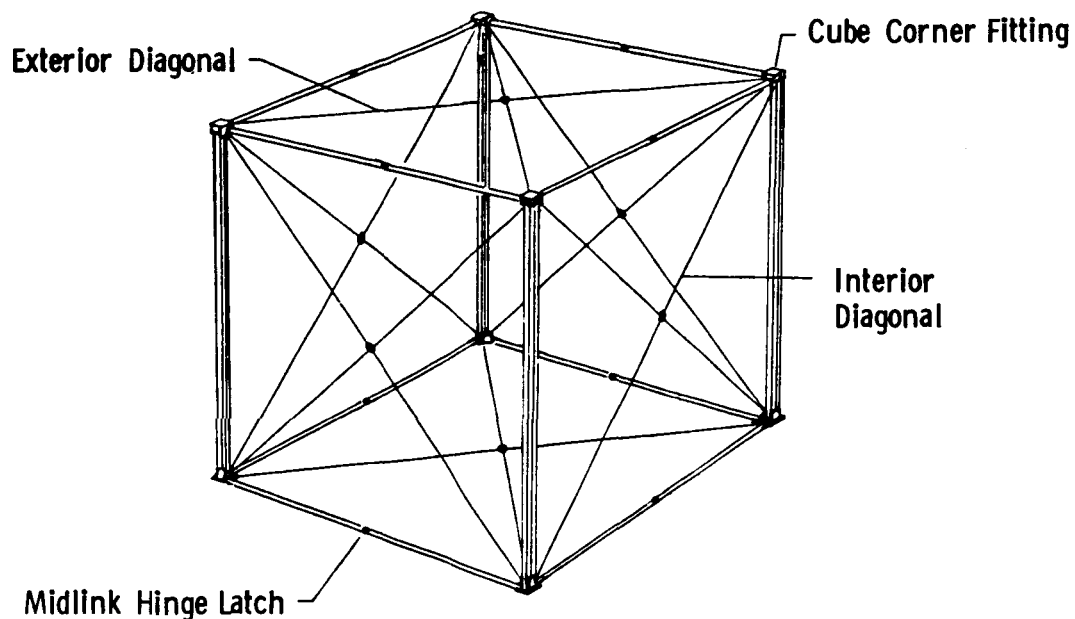

Figure 9. - Box truss with diagonal tensioning members

Size and Mass--Trends discerned in the analyses of large reflecting systems regarding size and mass are illustrated in figure 10. Note that mesh reflectors fall in between two types of membrane reflectors: (1) inflatables with flexible reflectors of polymer material, and (2) precision-structure-backed reflectors of metallic or glass material. These two types of

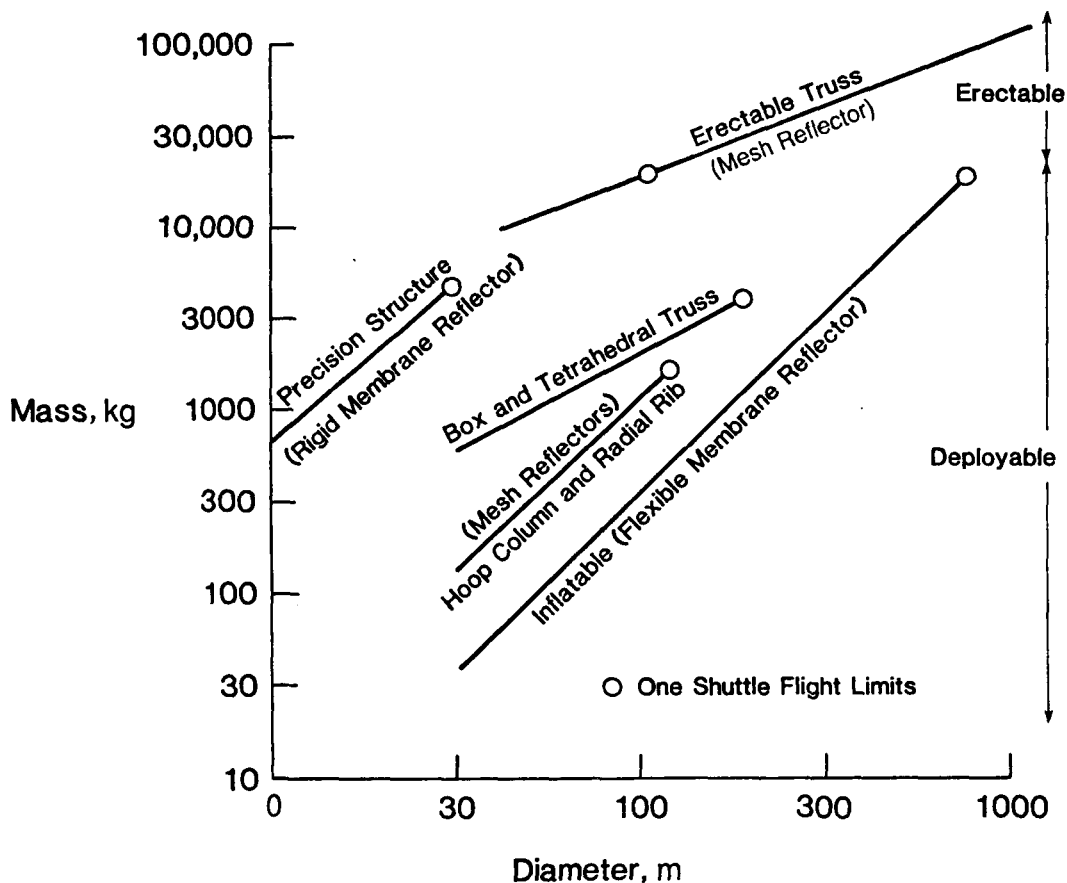

Figure 10. - Large reflecting antenna size and mass trends

reflectors may be used for relatively non-precision microwave and precision infrared applications, respectively. The mesh reflectors in comparison have the degree of precision required by many microwave communication and radiometric applications. They are mounted on structures which are either deployable or erectable (or a combination). SAB analysis of the four mesh deployable types indicates better mass/diameter slopes for truss structures than for the hoop column or radial rib structures, but since the initial truss structure mass is higher, the mass benefit does not manifest itself until diameters exceed 100 m. Similarly, erectable truss structures show mass benefits at diameters exceeding approximately 150 m and for payloads requiring

more than a single Shuttle flight. This applicability to very large systems and other attractive features of truss systems, made acutely obvious by the various LSA and Space Station design and analysis activities by SAB, are listed in Table 3.

Table 3. Truss Applicability

- Very Large Erectable Modular Systems
- Fundamentally Stiff, Strong, and Easy to Control
- Beams, Planar Structures, and Dishes
- Structurally Redundant
- Mounting Flexibility
- Easy to Model and Analyze

Analysis and Testing--The trend is accelerating toward analytical modeling and analysis becoming a full partner in any ground-based or flight testing program. Good modeling enables quantitative comparison of tests conducted using different designs and different test facilities, and in some cases, obviates the need for refined testing. For large structures that will not tolerate tests in Earth's 1 g, one atmosphere environment, accurate modeling is even more important for the testing which can only be done in space. For example, a relatively simple flight test of Scaled Truss Antenna Structures (STAS) was modeled and analyzed by SAB using the Space Technology Experiment Platform (STEP) on the Shuttle (see fig. 11).

Analysis, as a partner in flight testing, is particularly needed when flight models are large, extremely expensive, multidisciplinary freeflyers. Capability to analyze both the design and the "as-built" flight article is also a must in order to validate the technology and readily demonstrate its readiness for space flight.

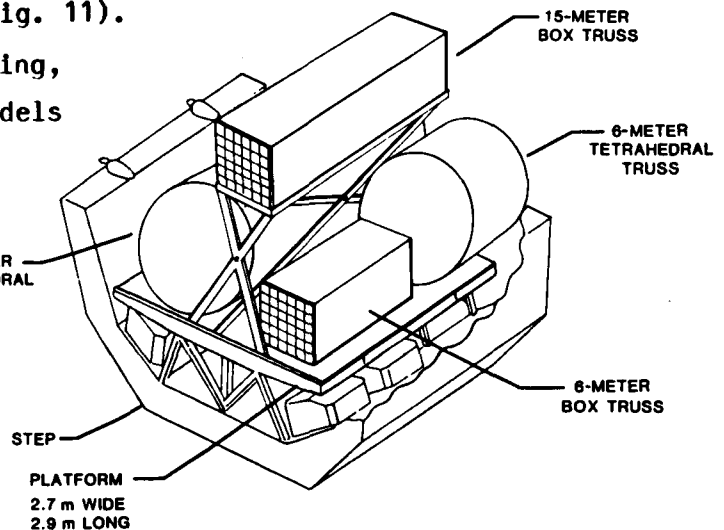

Figure 11. - Launch configuration of STAS mounted to STEP

THE CASE FOR SPACE SYSTEMS ANALYSIS

A LOOK TO THE FUTURE

This portrayal of large space deployable truss antenna development demonstrates the value of a rapid, high quality, computer-aided synthesis, analysis, and conceptual design capability applied to large space systems research and development. It also predicts a long-term potential for truss-type space structures.

It is inevitable that future updates and improvements in the analysis capability will be necessary. This extended capability will be used in conceptual studies, in preliminary designs of large truss systems, and in support of design validating flight tests. Already tasks are being defined for analysis supporting LSA flight demonstrations and for comprehensive analysis of Space Station concepts. Space Station analysis will address experiments to measure the "as built" station performance and verify the technologies applied. In addition, analysis may address mission requirements, engineering constraints, and the associated advanced subsystem technologies for operation in low Earth and higher orbits.

A further look into the future pictures the analysis capability being applied to research, technology, and development activities related to establishing human habitats on the Moon and Mars into the 21st Century.

1. Report No. NASA TM-89072		2. Government Accession No.		3. Recipient's Catalog No.	
4. Title and Subtitle Large Space Antennas: A Systems Analysis Case History				5. Report Date February 1987	
				6. Performing Organization Code 506-49-21-01	
7. Author(s) Lloyd S. Keafer and U. M. Lovelace, Compilers				8. Performing Organization Report No.	
9. Performing Organization Name and Address NASA Langley Research Center Hampton, VA 23665-5225				10. Work Unit No.	
				11. Contract or Grant No.	
12. Sponsoring Agency Name and Address National Aeronautics and Space Administration Washington, DC 20546-0001				13. Type of Report and Period Covered Technical Memorandum	
				14. Sponsoring Agency Code	
15. Supplementary Notes Lloyd S. Keafer, The Bionetics Corporation, Hampton, Virginia. U. M. Lovelace, Langley Research Center, Hampton, Virginia.					
16. Abstract The value of systems analysis and engineering is aptly demonstrated by the work on Large Space Antennas (LSA) by the NASA Langley Spacecraft Analysis Branch. This work was accomplished over the last half-decade by augmenting traditional system engineering, analysis, and design techniques with computer-aided engineering (CAE) techniques using the Langley-developed Interactive Design and Evaluation of Advanced Spacecraft (IDEAS) system. This report chronicles the research highlights and special systems analyses that focused the LSA work on <u>deployable truss</u> antennas. It notes developmental trends toward greater use of CAE techniques in their design and analysis. A look to the future envisions the application of improved systems analysis capabilities to advanced space systems such as an advanced space station or to lunar and Martian missions and human habitats.					
17. Key Words (Suggested by Author(s)) Systems Analysis Large Space Systems Computer-Aided Design			18. Distribution Statement Unclassified - Unlimited Subject Category 18		
19. Security Classif. (of this report) Unclassified		20. Security Classif. (of this page) Unclassified		21. No. of Pages 17	22. Price* A02