

**NASA  
Technical  
Memorandum**

NASA TM - 86590

**RAPID MELT/QUENCH FURNACE USING  
COMMERCIALY AVAILABLE HARDWARE**

Richard M. Poorman

Spacelab Payload Project Office

March 1987

(NASA-TM-86590) RAPID MELT/QUENCH FURNACE  
USING COMMERCIALY AVAILABLE HARDWARE (NASA)  
14 p CSCL 22A

N87-20431

G3/29 Unclas  
45446



National Aeronautics and  
Space Administration

**George C. Marshall Space Flight Center**

1. REPORT NO. NASA TM-86590		2. GOVERNMENT ACCESSION NO.		3. RECIPIENT'S CATALOG NO.	
4. TITLE AND SUBTITLE Rapid Melt/Quench Furnace Using Commercially Available Hardware				5. REPORT DATE March 1987	
				6. PERFORMING ORGANIZATION CODE JA62	
7. AUTHOR(S) Richard M. Poorman				8. PERFORMING ORGANIZATION REPORT #	
9. PERFORMING ORGANIZATION NAME AND ADDRESS George C. Marshall Space Flight Center Marshall Space Flight Center, Alabama 35812				10. WORK UNIT NO.	
				11. CONTRACT OR GRANT NO.	
				13. TYPE OF REPORT & PERIOD COVERED Technical Memorandum	
12. SPONSORING AGENCY NAME AND ADDRESS National Aeronautics and Space Administration Washington, D.C. 20546				14. SPONSORING AGENCY CODE	
15. SUPPLEMENTARY NOTES Spacelab Payload Project Office					
16. ABSTRACT  This report describes an off-the-shelf Orbital Tube Welder that can be easily used to melt and resolidify most any electrically conductive material. This can be done on a KC-135 Aircraft within the microgravity period of one parabola. Melt sizes 3 mm diameter by 10 mm length and larger are feasible with most if not all materials. A highly reproducible, controlled, programmable heat and cool cycle can be provided. Sample measurements would have to be developed and could be as sophisticated or as simple as desired. These could include: optical and thermocouple temperature measurements, Peltier pulser for marking the solidification fronts, dimensional changes and whatever. Sample heat flows could be fixed over a very wide range being limited mostly by the cooling period, the desired sample size, and the 20 sec microgravity period of the KC-135 Aircraft parabola.					
17. KEY WORDS Microgravity, Melt, Resolidify, Composite materials, KC-135 Aircraft Directional Solidification			18. DISTRIBUTION STATEMENT Unclassified/Unlimited		
19. SECURITY CLASSIF. (of this report) Unclassified		20. SECURITY CLASSIF. (of this page) Unclassified		21. NO. OF PAGES 14	22. PRICE NTIS

# TABLE OF CONTENTS

	Page
BACKGROUND .....	1
OBJECTIVE.....	1
APPROACH.....	1
SAMPLE CONFIGURATION.....	2
ON BOARD THE KC-135.....	2
FEASIBILITY TESTS .....	4
CONCLUSION .....	7
APPENDIX A .....	9

**PRECEDING PAGE BLANK NOT FILMED**

**PRECEDING PAGE BLANK NOT FILMED**

## LIST OF ILLUSTRATIONS

Figure	Title	Page
1.	Rapid melt/rapid quench configuration.....	2
2.	Sample No. 4 – aluminum alloy 4043 longitudinal cross section .....	3
3.	Aluminum samples .....	5
4.	Copper and tungsten samples .....	6

## TECHNICAL MEMORANDUM

### **RAPID MELT/QUENCH FURNACE USING COMMERCIALY AVAILABLE HARDWARE**

#### **BACKGROUND**

Microgravity science experimenters are regularly melting and resolidifying materials in various gravity fields. Drop Tube, Drop Tower, and Aircraft are the only NASA facilities providing microgravity environments today. These facilities provide relatively short low-gravity periods. And, as one might expect, melting and resolidifying in shorter and shorter low-gravity periods are increasingly difficult. Smaller samples tend to ease the difficulties in accomplishing melt/resolidification within short low-gravity periods.

Recently, an interest was expressed in melting and resolidifying in one low-gravity parabola aboard a KC-135 Aircraft. This interest was primarily for materials which would have segregation when they were molten. It includes a wide variety of materials, but mostly, metallic, and/or composite materials.

Basically, to process such materials in one KC-135 parabola means melting and resolidifying in approximately 20 sec or less. Most investigators want large samples and directional solidification. This report will present an approach for accomplishing such material processing.

#### **OBJECTIVE**

The objective is to melt and resolidify a sample of material within the 20 sec low-gravity period flown by a KC-135 Aircraft. Sample diameters of 2 to 5 mm and lengths of 10 to 20 mm were given by one experimenter.

#### **APPROACH**

The approach here is to surround the sample with relatively large heat sinks. The sample itself would be rapidly heated near its center with an intense energy source. This source might be a laser, focused thermal radiation, electron beam, and/or conventional inert gas tungsten arc. Feasibility tests have been made using the latter.

These tests included the use of a commercial Orbital Tube Welder. Several different companies supply highly refined Orbital Tube Welders which totally enclose the work piece. Attached is a brochure of such a commercial unit. Its flexibility and its capability to rigorously control the weld parameters are noteworthy. In particular, the weld arc can move around the sample

in a programmable manner at speeds up to 60 rpm. Weld current is timed and programmed with up to four different current levels. Arc length and position are adjustable and all are very reproducible as required in complex tube welds of highly reactive materials.

### SAMPLE CONFIGURATION

The sample is conceived to be a rod between two large rod-shaped heat sinks (Fig. 1). This configuration can provide directional solidification as shown in the longitudinal section (Fig. 2). Directional solidification is often considered to be desirable. By reducing the heat flow down the rod, solidification from the outside toward the middle can predominate, e.g., nondirectional solidification. Thus, a wide variety of solidification patterns can be provided by controlling the heat flow both to and from the sample.

### ON BOARD THE KC-135

The Orbital Tube Welding system can be readily adapted to operations onboard a KC-135 Aircraft. The 100 V, 60 Hz, 20 A circuit, on board, will provide adequate power for the proposed 100 A DCSP weld currents. The 90 lb power supply, tube weld head, and remote pendant can provide easy control. Sample changes during flight between parabolas would be readily accomplished.

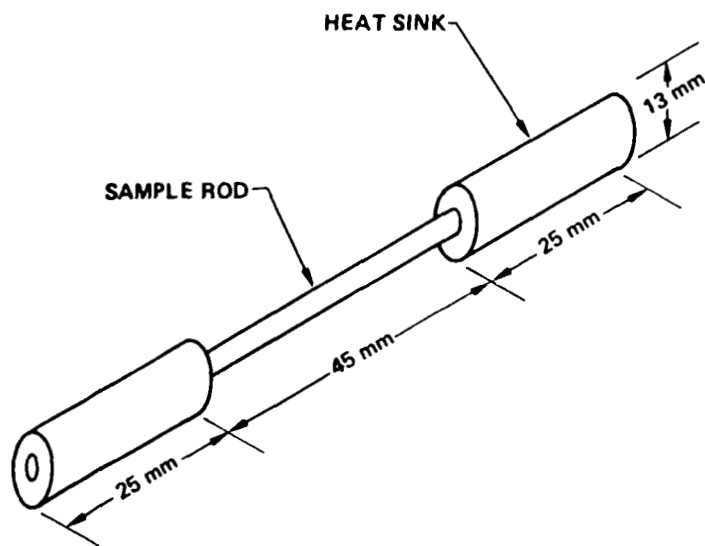

Figure 1. Rapid melt/rapid quench configuration.

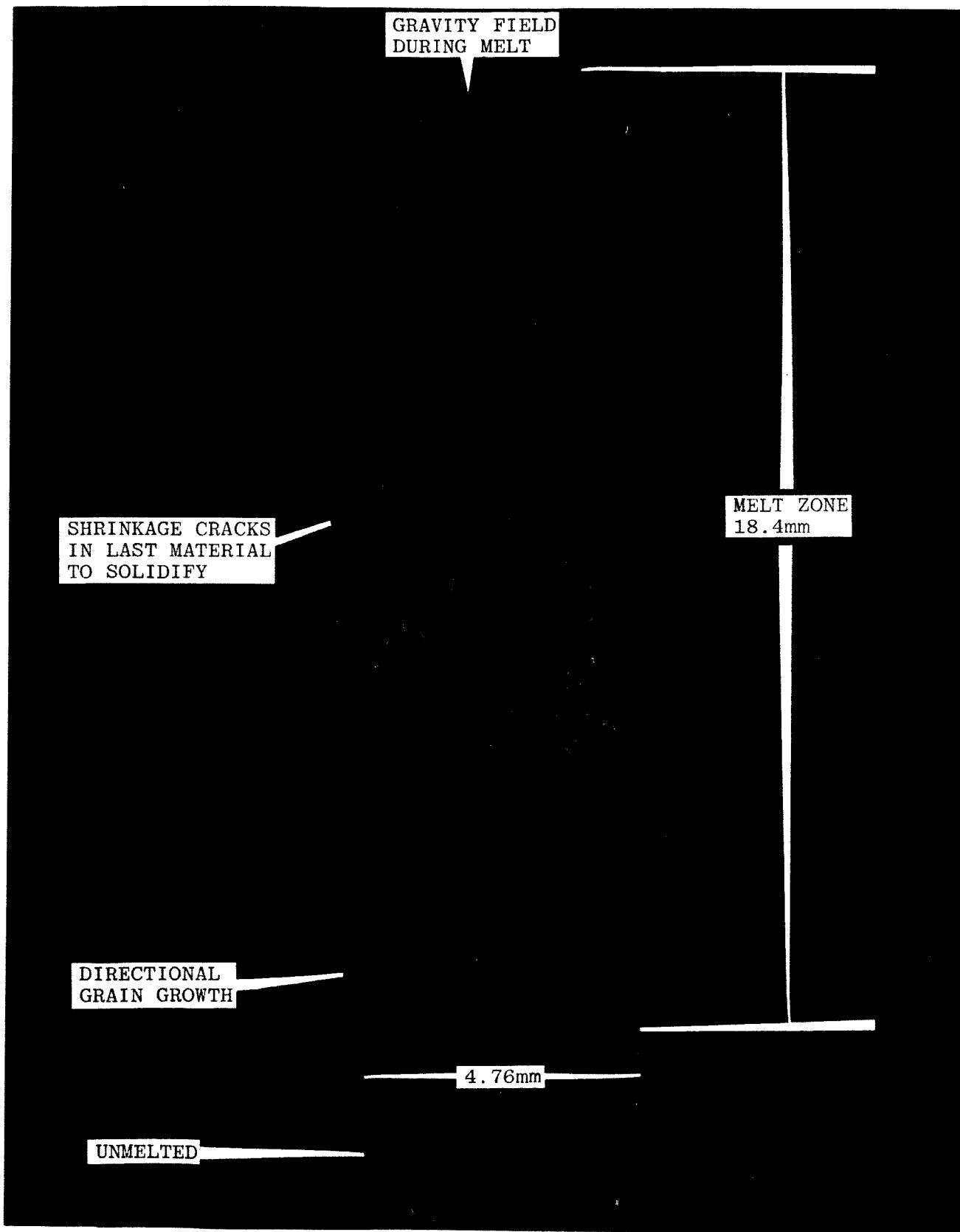

Figure 2. Sample No. 4 - aluminum alloy 4043 longitudinal cross section.

## FEASIBILITY TESTS

Preliminary tests were made with aluminum, stainless steel, and tungsten. These tests were made with a standard GTA welding torch. While supporting a long rod away from the center and in a horizontal position, an arc was established at the center. The torch was hand held in a vertical-down position. Using various arc currents, it was readily apparent that samples of aluminum, stainless steel and tungsten, 3 mm diameter and larger, could be melted in less than 10 sec using less than 100 A DCSP.

Arrangements for demonstration melts were then made with one supplier of Orbital Tube Welders. All samples were made by fitting the sample rod with aluminum heat sinks on each end. The sample rods were 90 mm long. The fitted heat sinks were 13 mm diameter by 25 mm long aluminum. This left a free sample length of 45 mm.

Sample rods of aluminum, copper and tungsten were prepared. Table 1 shows the heat and test parameters used. All heating periods were 5 sec except sample No. 10. Sample No. 10 was heated 6 sec. The approximate nugget size is also shown in Table 1.

Figures 3 and 4 show the resolidified surface appearance of sample Nos. 4, 6, 8, 9, and 10. The arc path is clearly identifiable on all materials except tungsten. And of course, the nugget size was small enough that the surface tension held the melt against the gravity field (1-g). That is, all except sample No. 10; surface tension did not hold and the sample separated in the final stages of melting.

TABLE 1.

<u>SAMPLE No.</u>	<u>MATERIAL</u>	<u>ARC LENGTH</u>	<u>CURRENT</u>	<u>RPM</u>	<u>POSITION</u>	<u>NUGGET SIZE</u>	<u>REMARKS</u>
1	ALUMINUM	6.35mm	30 AMP.	24	HOR.	4.76 x 5.33mm	
2	ALUMINUM	12.4mm	30 AMP.	24	HOR.	4.76 x 6.2mm	
3	ALUMINUM	12.4mm	30 AMP.	8	HOR.	4.76 x 7.1mm	NUGGET IS LONGER ON TOP. ARC STARTED ON SIDE AND MOVED UNDER
4	ALUMINUM	12.4mm	50 AMP.	24	VERT.	4.76 x 18.4mm	
5	ALUMINUM	12.4mm	50 AMP.	24	HOR.	6.2 x 5.7mm	
6	ALUMINUM	12.4mm	75 AMP.	24	VERT.	6.2 x 13.9mm	
7	COPPER	12.4mm	75 AMP.	24	VERT.	4.1 x 3.2mm	
8	COPPER	12.4mm	75 AMP.	24	HOR.	4.1 x 4.3mm	NUGGET SAGGED ABOUT 1.5mm
9	TUNGSTEN	12.4mm	90 AMP.	24	VERT.	3.2 x 2.8mm	
10	TUNGSTEN	12.4mm	100 AMP.	24	VERT.	3.2mm	GRAVITY OPENED MELT ZONE

NOTES: ARC LENGTHS RESULTED IN VOLTAGES OF 9 AND 14 VOLTS. (ARGON SHIELDING GAS) (DCSP)  
 NUGGET SIZES ARE SAMPLE DIAMETER X NUGGET LENGTH IN MILLIMETERS.  
 ALL SAMPLES WERE MADE AT MERRICK ENGINEERING, NASHVILLE ON AN ORBITAL TUBE WELDER.  
 RPM IS THE RATE THE ARC MOVED AROUND THE SAMPLE (REVOLUTIONS PER MINUTE).



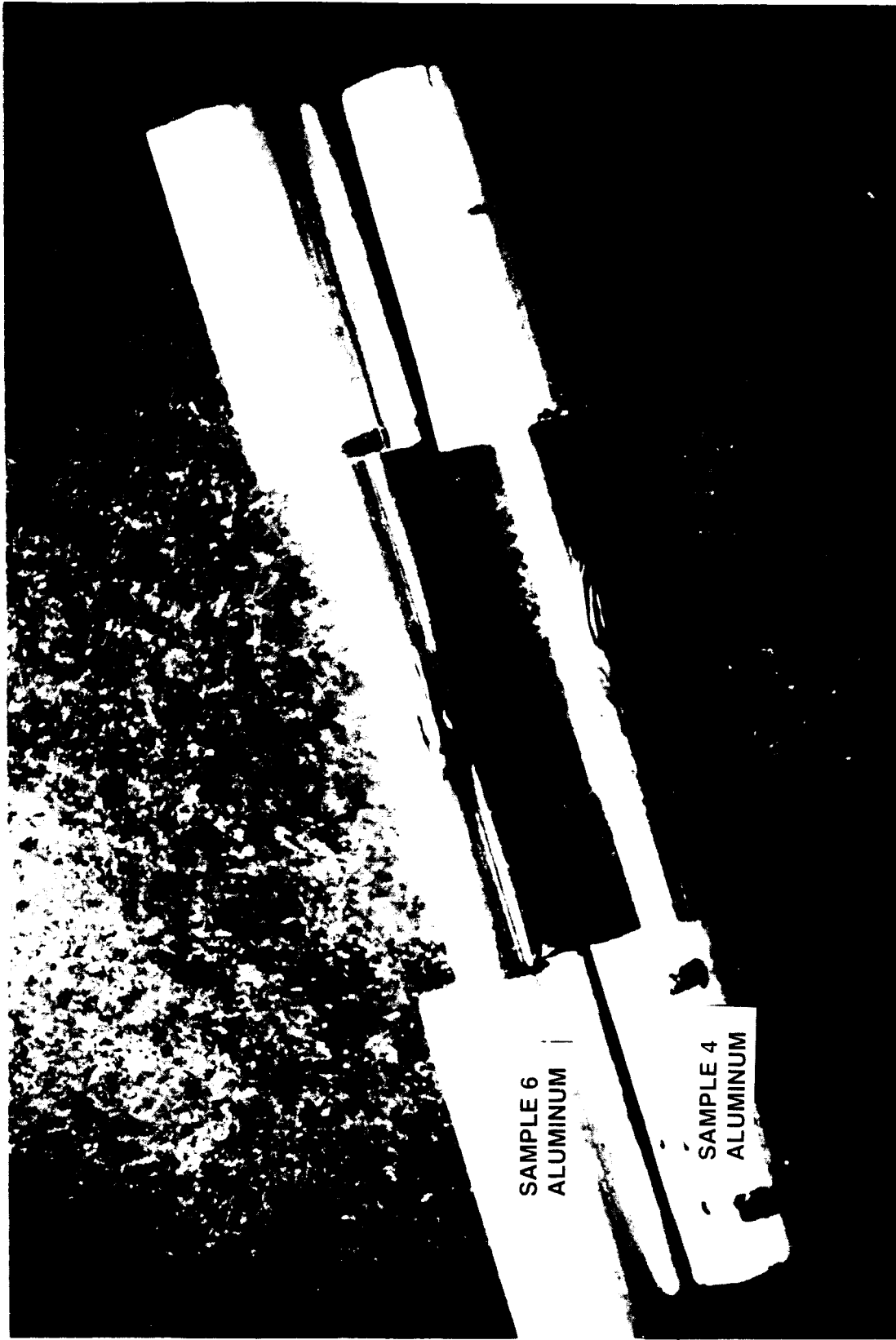

FIGURE 3. ALUMINUM SAMPLES

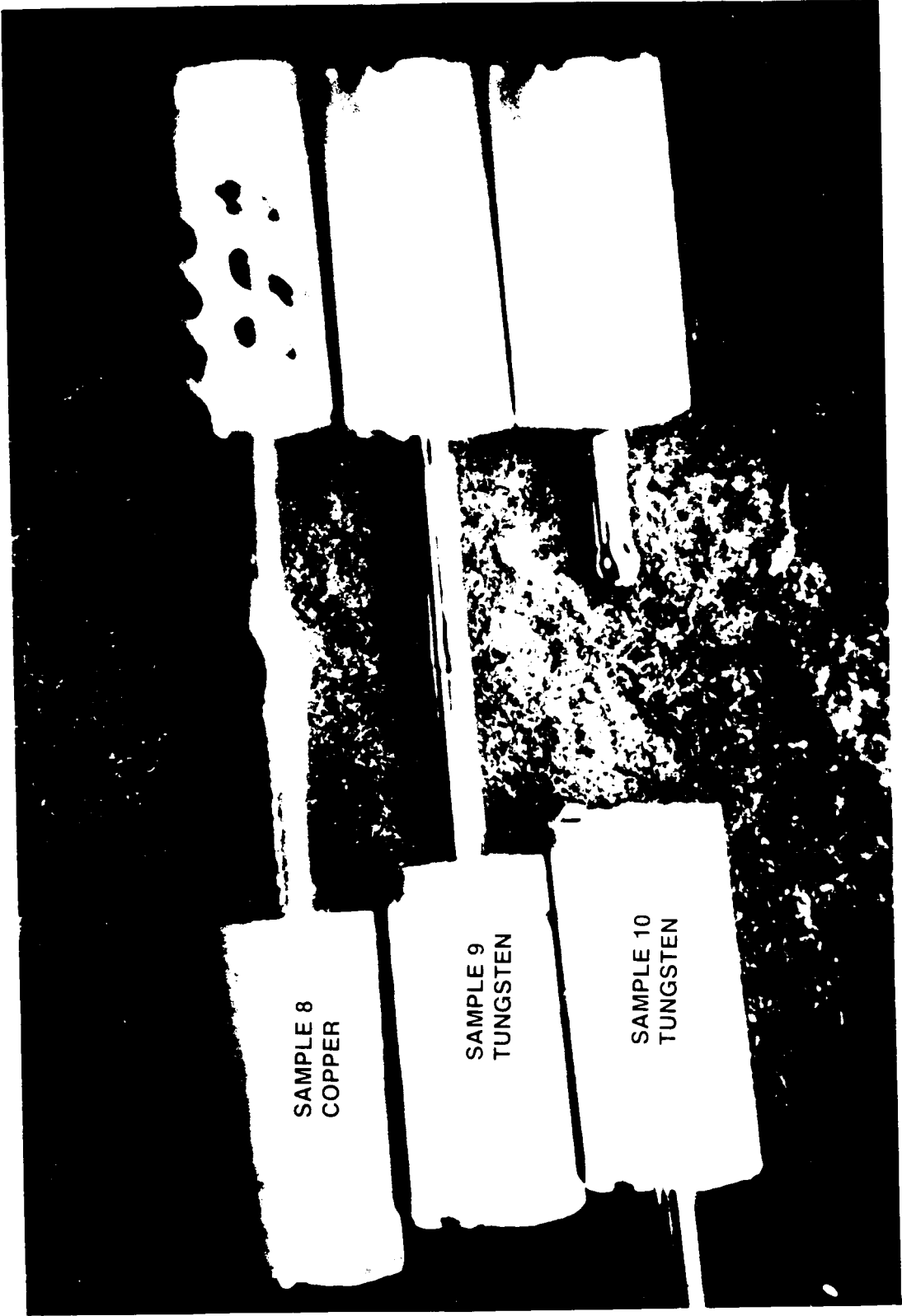

FIGURE 4. COPPER AND TUNGSTEN SAMPLES

The arc line will require some study. Electrode shape and material will be important parameters. A very pointed tungsten electrode was used in these tests and probably exaggerates the arc line. The 1.6 mm diameter electrode was sharp and had about 15 deg included angle on the arc end.

## **CONCLUSION**

It seems readily apparent that an off-the-shelf Orbital Tube Welder can be easily used to melt and resolidify most any electrically conductive material. It can be done on a KC-135 Aircraft within the microgravity period of one parabola. Melt sizes 3 mm diameter by 10 mm length and larger are feasible with most if not all materials. A highly reproducible, controlled, programmable heat and cool cycle can be provided. Sample measurements would have to be developed and could be as sophisticated or as simple as desired. These could include: optical and thermal-couple temperature measurements, Peltier pulser for marking the solidification fronts, dimensional changes, and whatever. Sample heat flows could be fixed over a very wide range being limited mostly by the cooling period, the desired sample size, and the 20-sec microgravity period of the KC-135 Aircraft parabola.

THIS PAGE INTENTIONALLY LEFT BLANK



# AUTOMATIC TUBE WELDER

MODEL PA-100-STW

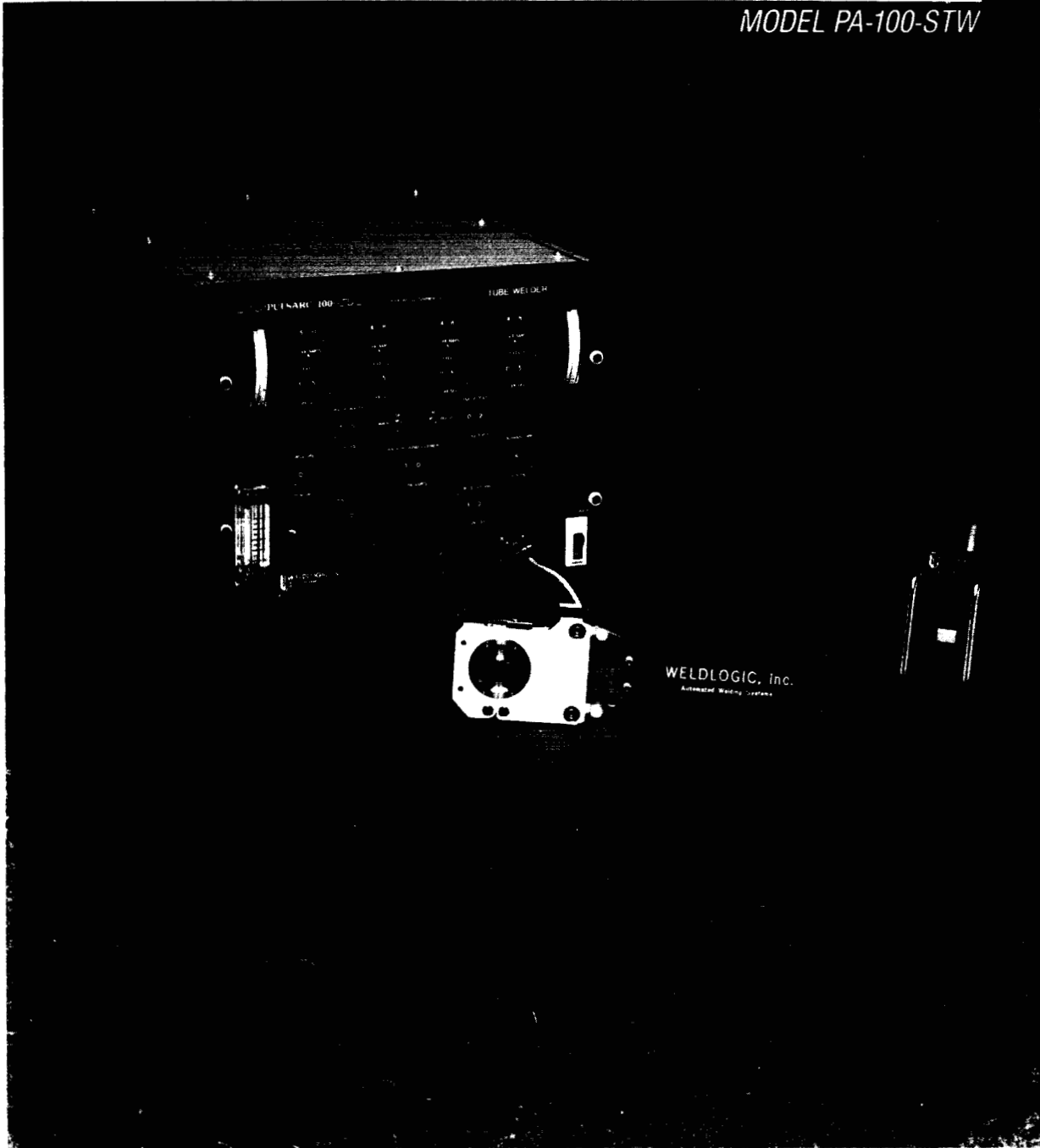

# AUTOMATIC TUBE WELDER

## MODEL PA-100-STW

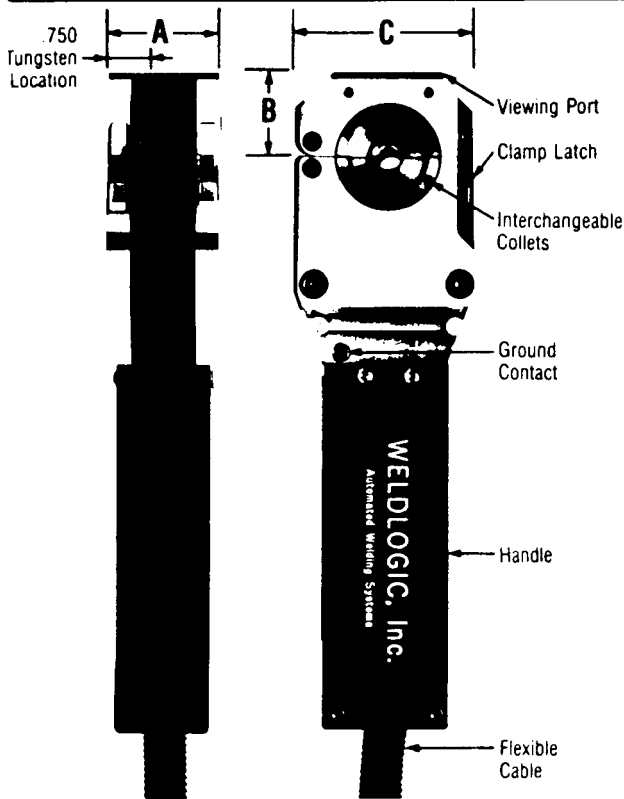

Standard Sizes	Dim. A	Dim. B	Dim. C	Tube Dia. Range
Model STW 101	2.00" (5.08cm)	1.0" (2.54cm)	2.75" (6.99cm)	1/8" to 1/2"
Model STW 102	2.35" (5.97cm)	1.815" (4.61cm)	3.875" (9.84cm)	1/4" to 1 1/2"
Model STW 103	2.350" (5.97cm)	2.765" (7.02cm)	5.75" (14.61cm)	1" to 3"

**MODEL PA-100-STW** The Weldlogic PA-100-STW tube weld power supply is designed for automatic all position autogenous pulsed arc (TIG) welding of all weldable grades of tubing. The power supply has been housed in a portable yet rugged aluminum enclosure suitable for site use and is conveniently powered by any 115V AC (200/220V AC available). The power supply is a very stable, precise 100 ampere transistor controlled solid state system. All weld parameters are direct digital readout with a repeatability factor of  $\pm 1\%$  with line voltage variations of  $\pm 12\%$ . In operation, the tubing is located in the collets of the STW series head and locked into position. A view port in the top of the head provides verification of alignment.

By initiating the "SEQ START" button the closed servo feed back precisely controls and monitors the entire automatic weld sequence from preflow through four independently adjustable timed weld currents into downslope and post purge. The results are a high quality "push button" completely automatic orbital tube weld that can meet the most demanding welding criteria.

**ORBITAL TUBE WELD HEADS** The Weldlogic model PA-100-STW tube welding power supply and control system is designed to be used with Weldlogic's STW series Orbital Tube Weld Heads. Standard weld heads accommodate tubing from 1/2" dia (3.2mm), to 3.00" dia (76mm). The weld heads listed are standard production models combining ruggedness with precision. Weldlogic also designs special application tube heads to meet your specific mechanical requirements.

**REMOTE OPERATORS PENDANT** An operators pendant control is provided with each PA-100-STW to assist in cases where the weld is located out of immediate reach of the power supply. The operators pendant provides all the control functions for the weld head and power supply remote sequencing. The operators pendant control is supplied with 25' (7.7m) cable (control functions listed below).

**MANUAL WELDING** The PA-100-STW tube welding system may be operated with a model PA-ADJ-3 foot operated current control. This feature provides a very practical capability for manual TIG use, for tacking or repair welding.

**EXTENSION CABLES** Optional extension cables are available for all accessories and weld heads.

### CONTROL SPECIFICATIONS

#### PA-100-STW

Size:	12" T x 16" W x 21" L (304mm x 406mm x 533mm)	Switches:	1-99 pulses per second 0-99 amps background current 0-9 seconds downslope 0-99 seconds pre flow gas 0-99 seconds post flow gas 0-9 seconds rotation delay 0-99% tachometer speed control
Weight:	90 lbs. (40.7 kg)	Toggle Switches:	Pulsation ON/OFF
Meters:	0-100 amps 0-50 volts	Flow Meter:	0-50 CFH
Thumbwheel:	0-9 seconds upslope	Circuit Breaker:	Power ON/OFF, 20 F.L. amps
Digital:	0-99% pulse width		
Switches:	0-99 amps (Level 1,2,3,4) 0-99 seconds (Level 1,2,3,4)		

#### REMOTE OPERATORS PENDANT

Push Buttons:	Sequence start Sequence stop Return to home Jog Purge—MAN/AUTO
---------------	--

(Specifications subject to change)

"Advancing the  
Science of Welding"



**WELDLOGIC, Inc.**  
Automated Welding Systems

9730 Varie! Avenue • Chatsworth, California 91311 • (818) 709-6006 • Telex: 3781686 WELDLOGIC

## APPROVAL

### RAPID MELT/QUENCH FURNACE USING COMMERCIALY AVAILABLE HARDWARE

By Richard M. Poorman

The information in this report has been reviewed for technical content. Review of any information concerning Department of Defense or nuclear energy activities or programs has been made by the MSFC Security Classification Officer. This report, in its entirety, has been determined to be unclassified.

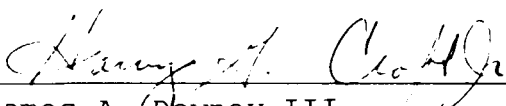
  
\_\_\_\_\_  
James A. Downey III  
Manager, Spacelab Payload Project Office