

SATELLITE ANALOG FDMA/FM TO DIGITAL TDMA CONVERSION FINAL REPORT

April 1987

(NASA-CR-179605) SATELLITE ANALOG FDMA/FM
TO DIGITAL TDMA CONVERSION Final Report,
May - Dec. 1986 (Ford Aerospace and
Communications Corp.) 72 p

N87-20467

CSCL 09C

G3/33 Unclas
45167

NASA
NASA LEWIS RESEARCH CENTER
Contract No.: NAS3-24890

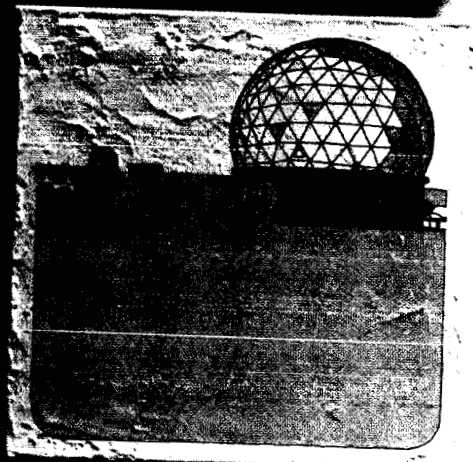
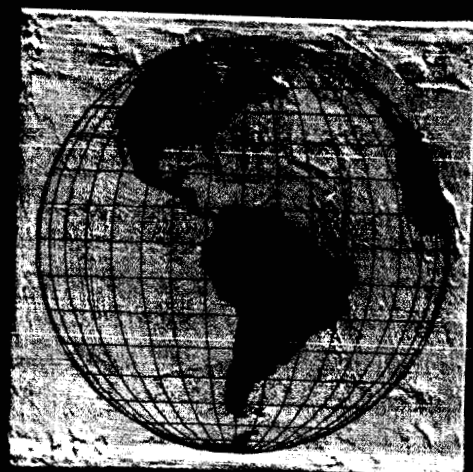
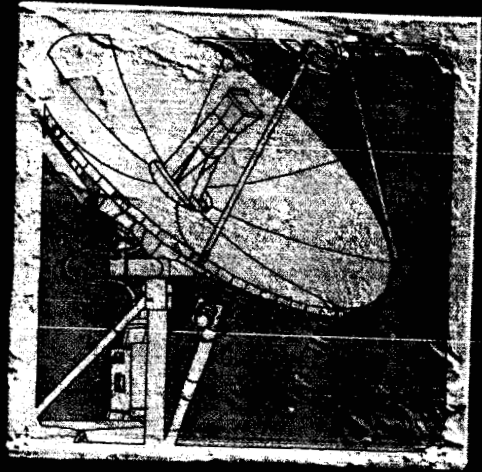

1. Report No. CR 179605	2. Government Accession No.	3. Recipient's Catalog No.	
4. Title and Subtitle Satellite Analog FDMA/FM to Digital TDMA Conversion		5. Report Date April, 1987	6. Performing Organization Code 650-60-26
		8. Performing Organization Report No. WDL- TR11068	
7. Author(s) T. Driggers, T. Nguyen, V. Kolavennu		10. Work Unit No.	
9. Performing Organization Name and Address Ford Aerospace & Communications Corp 3939 Fabian Way Palo Alto, CA 94303		11. Contract or Grant No. NAS3-24890	
		13. Type of Report and Period Covered Final May 1986-Dec 1986	
12. Sponsoring Agency Name and Address NASA Lewis Research Center 21000 Brookpark Road Cleveland, Ohio 44135		14. Sponsoring Agency Code	
15. Supplementary Notes NASA Program Manager. William A. Poley			
16. Abstract This Final Report presents the results of a Ford Aerospace and Communications Corporation study which investigated design issues regarding the use of analog to digital (A/D) conversion on board a satellite. The study was conducted for NASA Lewis Research Center under contract No. NAS3-24890. The need for A/D, and of course D/A as well, conversion arose from a satellite design which required routing analog FDMA/FM up and down links to/from a digitally modulated (i.e., QPSK) inter-satellite link. There are also some advantages when one must interconnect a large number of various spot beams which are using analog, and therefore cannot take advantage of SS/TDMA switching among the beams, thus resulting in low fill factors. Various tradeoffs were performed regarding the implementation of on-board A/D processing, including mass, power, and costs. The various technologies which were considered included flash ADCs, surface acoustic wave (SAW) devices, and digital signal processing (DSP) chips. Impact analyses were also performed to determine the effect on ground stations to convert to digital if the A/D approach were not implemented.			
17. Key Words (Suggested by Author(s)) Analog/Digital Conversion Digital switching.		18. Distribution Statement General Release	
19. Security Classif. (of this report) Unclassified	20. Security Classif. (of this page) Unclassified	21. No. of Pages 70	22. Price*

* For sale by the National Technical Information Service, Springfield, Virginia 22161

1.0 OVERVIEW

1.1 Purpose

This study was performed by Ford Aerospace and Communications Corporation to investigate design issues regarding the utilization of analog to digital (A/D) conversion on board a satellite. The concept originated as part of the NASA Communications Platform Payload Definition (CPPD) Study, Ref [1], conducted by FACC. One of the payload concepts developed in that study required routing Intelsat traffic from Latin America/Caribbean countries via an intersatellite link (ISL) to Europe. It was assumed that many of these countries would continue to use FDMA/FM, whereas the ISL used digital modulation; hence A/D (and of course D/A) conversion would be required under these assumptions.

Under the FDMA/FM approach, it was highly desirable that different accesses within a (36 MHz) transponder be independently routed or switched to the ISL or other beams, since the Intelsat gateway stations were covered by several small spot beams. If an entire 36 MHz transponder were the smallest switchable unit, then very poor fill factors would have resulted. The fill factor issue also applied to U.S. domestic coverage as well. The issue of fills has also been considered in this study.

The objectives of the study were as follows:

- Perform assesment of applications where A/D and D/A conversion could enhance system architectures
- Analyze technical performance of various alternative systems
- Perform economic comparisons involving selected system(s)

1.2 Approach

The study was organized into the following tasks:

- Task 1: Develop a data base of cost and performance of various potential hardware components, numbers of ground station users, and traffic estimates.
- Task 2: Develop candidate concepts to the block diagram level, with emphasis on A/D conversion, but including D/A.
- Task 3: Refine the approach(es) from Task 2 selected by NASA and generate bottom line economic comparisons with a no on-board conversion architecture; determine other advantages/disadvantages of the selected system(s).

1.3 Selected Concept

The basic approaches considered were:

- (1) Analog filtering prior to A/D
 - Switchable filter banks
 - Programmable filters

(2) Digital filtering after A/D

- Frequency domain processing
- Time domain processing

Based on cost, mass, and power considerations, the analog filtering with switchable filter banks was deemed to be the preferred approach. Although the use of 1993 technologies showed digital closing the gap somewhat, the selected approach still maintained its advantage.

1.4 Economic Analysis

A detailed analysis was performed for the selected approach, comparing the use of on-board A/D conversion with other approaches, such as converting earth stations to digital modulation, with on-board demodulation for switching/routing of the accesses. An overall summary of the costs for the two approaches (with and without A/D) is presented in Tables 1 and 2 for the Intelsat and U.S. domestic situations respectively.

If no on-board A/D conversion is provided in the international situation, then it must be performed on the ground, because of the assumption that an ISL uses digital modulation. There is no forcing requirement to convert to digital in the U.S. domestic situation, and so earth station costs are not included in Table 2. Sections 4.1.3 and 4.2.3 provide additional details.

1.5 Major Findings

The use of A/D and D/A conversion on board a satellite can provide flexible routing between analog users and digital inter-satellite links, as well as improved fill factors of static switched transponders. The provision of this capability appears to have significant cost advantages over ground-based solutions in the former case, and also in the latter case under some circumstances.

In the arena of technology development, the preferred approach for A/D conversion used hardware which exists today. There would need to be some space qualification of the hardware, but no significant problems are seen there. The major development would be the high speed digital switch required to handle the data rates output by the A/D converters.

2.0 Component Cost and Performance

As a preliminary to the technical analysis of various approaches and their economic impact, data bases of appropriate hardware, traffic affected, and ground station users were developed.

2.1 Data Base Description

This subsection provides the summary descriptions of the various current state-of-the-art product data-bases. The first part provides the cost/performance comparisons of the flash A/D converter products. The second part compares the cost/performance trade offs of the high-speed D/A converter products. The third part provides the information on the digital signal processing (DSP) products. The last part of this subsection provides the performance capabilities of surface acoustic wave (SAW) filters with the currently available, and projected 1993 state-of-the-art parts.

2.1.1 Flash Analog-to-Digital-Converters:

The price/performance comparison of the flash A/D converters is shown in Tables 3 and 4. They show that the lower the resolution, sampling frequency and linearity requirements, the lower the price of the A/D converters. Also, it is easier to implement with CMOS type low-power technologies at lower sampling frequencies, whereas the higher frequency operations may require ECL or bipolar logic implementations, which have much higher power requirements. Sony currently provides an A/D converter (model: CX20016) with 8 bit-resolution and with acceptable sampling frequencies of up to 100 MHz and input signal bandwidths of up to 40 MHz. A/D parts offered by TRW (TDC1029), Analog Devices (AD5010KD) and Siemens (SDA5200) can also accept sampling frequencies of up to 100 MHz, but provide only 6 bits of resolution. All are ECL implementations, requiring a minimum power of 1W. In comparison, the A/D parts for sampling rates of 10 MHz or below, are available from many more vendors and provide better overall performance to price ratio (i.e., better resolution, lower power-requirements and much lower prices

2.1.2 High-Speed Digital-to-Analog Converters:

Table 5 presents the price-performance features of the currently available D/A converters. From this table, it is easy to infer that the current state of technology allows implementation of D/A converters at much higher speeds than the A/D converters and at a much lower cost. For example Honeywell offers a D/A converter (model: HDAC-9700), which can accept 8-bit input digital signals at rates of up to 200 MHz. Sony offers a D/A converter (model: CX20201) which accepts input digital signals of resolutions of upto 10 bits and at rates of up to 100 MHz.

2.1.3 Digital Signal Processing Integrated Circuits:

Table 6 lists a few Digital Signal Processing (DSP) chips, currently available from TRW and Zoran. This table shows that the current state-of-art of technology limits the maximum rates to 20 MHz for these signal-chip implementations of the DSP functions. The maximum number of cells per chip is 8 and the maximum number of taps implementable with multiple chips is limited to 1,032.

2.1.4 Surface Acoustic Wave (SAW) Analog Filters:

Table 7 shows the capabilities of SAW analog filter implementations with the current state-of-the-art parts. This table clearly shows that the filter implementation for the on-board A/D processing with analog filtering approach, is completely feasible with the current state-of-the-art part. We shall elaborate on this issue later. By 1993, the SAW technology is expected to be much more mature and the required entire filter-banks are expected to be implemented on a small (2"x4") PC Board.

2.2 Derivation of A/D Traffic

2.2.1 Traffic Definition

The quantity of analog traffic which is subject to the satellite on-board A/D and D/A conversion is the Fixed Satellite Service traffic of the two areas described in the following subsections.

2.2.1.1 Latin America/Carribbean Traffic Area.

The traffic is made up of all Region 2 international FSS analog traffic: (1) between the countries

within the area of Latin America and the Caribbean; (2) between the area of Latin America/Caribbean and the continental US; and (3) between Region 2 and all other regions through the intersatellite links.

This traffic is routed through international gateway earth stations of the countries of this area.

2.2.1.2 US Domestic.

The traffic considered for U.S. domestic areas which had potential for A/D application is that traffic assigned to the 12 MHz or 18 MHz transponders in the CPPD study. These "narrow band" transponders were included to improve fill and provide a little more flexibility in routing/switching. With 9 beams and only 12 transponders, flexibility would have been minimal. The use of A/D on-board conversion provides even greater flexibility than the use of narrow-band transponders.

2.2.2. Traffic Derivation

For the Latin America/Caribbean area, the most likely (or "medium") estimate is the INTELSAT traffic forecast used in the CPPD study. This forecast is based on the August, 1984 INTELSAT Traffic Model. The nominal growth rate for Atlantic Ocean Region (AOR) traffic in that forecast is 8%. The growth rates are adjusted for low and high level estimates based on the following growth rates:

	Low	Medium	High
	4%	8%	12%

For US area, the most likely estimate is the NASA U.S. domestic traffic forecast used in the CPPD study. This forecast is based on the NASA FSS Traffic Model, Ref [2], plus FACC estimates of growth rates beyond the year 2000.

The assumed growth rates are:

	Low	Medium	High
1985-2000	10%	14%	14%
2000-2008	6%	10.5%	14%

Based on the above assumptions, Table 8 summarizes the total traffic where A/D conversion could be used.

2.3 Derivation of Access Sizes

A trade-off exists between the number of accesses within a 36 MHz transponder and the resulting fill factors; the smaller the access size (the larger the number of accesses), the higher the resulting fills. However, one reaches a point of diminishing returns regarding the fills, and so there is an "optimal" size, at least in an overall average sense.

A simple program was developed to process the traffic matrices developed for Latin America/Caribbean in the CPPD study. This program considered a three level hierarchy, which is quite similar to the multiplexing hierarchy used in terrestrial communications systems - e.g., channel groups, supergroups, and mastergroups. This allows the flexibility to match the size of accesses to the actual traffic in an access. To illustrate, consider two access sizes of 20 and 100 circuits. If a particular traffic bundle (access) were 80 circuits, then one could use either a single "large" group at 80% fill, or four "small" groups at 100% fill. The latter provides higher fills, but at the cost of more equipment.

The program mentioned in the previous paragraph simply iterates on various sizes for the level 1 (smallest) and level 2 groups. Level 3 is fixed at the entire 36 MHz transponder. One other input to the program is the minimum fill required to establish a level 2 or 3 group. To use the above example, if the minimum fill were 75%, then an access of size 100 would be selected; if the minimum fill were set to 90% (greater than the 80% fill actually attainable) then the traffic bundle would be "overflowed" to the next lower level, and four groups of 20 would be used. Appendix A contains sample outputs of the program, and the results are summarized in Figure 1. Three minimum fills were used: 85%, 70%, and 50%. At the two higher fills, the choice of level 2 size had a negligible effect on the results, so only a single (solid) curve for fill is indicated. For the 50% case, two curves are shown, one through the set of minimum fills (given the level 1 size) and one through the set of maximum fills for each level 1 value.

The dotted lines represent the total number of groups required, and are a rough measure of the amount of hardware required. The trade-off point chosen is circled on the graph, and corresponds to level sizes of 96, 480, and 2400 circuits, or in terms of MHz (ignoring guard bands), 1.44, 7.2, and 36 MHz respectively.

To provide a flexible capability within each transponder, a switchable filter scheme, shown in Figure 2, was developed. The ratios of the number of groups at the two lower levels are based on the total number of groups at each level. Thus, one can have a single 36 MHz access, or three to five 7.2 MHz accesses, or up to ten 1.44 MHz accesses. The selection is made using switchable filter banks, as described in Section 3.2.1.

2.4 DERIVATION OF A/D GROUND STATION USERS

2.4.1 Number of ground stations in Latin America/Caribbean area.

International traffic in the Latin America/Caribbean countries are routed through ground stations functioning as international gateways. By their function and due to regulatory issues (one PTT per country), the number of international gateways is limited to 1 or 2 at the most (Brazil) for each country. The number of those stations is quite stable and independent of the traffic. At most, a fluctuation of 5 countries about the 1984 number (27) is assumed.

2.4.2 Estimation of Number of Ground Stations in U.S. Area

In terms of Fixed Satellite Service, earth stations in the US can be categorized into (1) trunking stations handling voice trunking, data trunking and video conferencing trunking and (2) customer premise service (CPS) stations. The on-premise CPS station carries a mixed and relatively light traffic volume of voice, data and video conferencing, such traffic being processed beforehand into digital formats for ease of use and efficient transmission. Therefore only trunking stations operated by the common carriers for shared use will carry analog traffic by year 2008.

The number of carrier (shared use) trunking stations for year 1984 was obtained in the CPPD study based on a survey of FCC filings for a total of 575 stations. Because these stations are operated by common carriers, US international traffic may be routed through any of those stations. The methodology for estimating the increase in number of stations carrying analog traffic from year 1984 to 2008 is based on following assumptions:

- The growth rates for total earth stations correspond to traffic growth (Section 2.2.2)
- Due to assumed emergence of Ka-band in the time frames involved, the number of earth stations for analog is proportional to the bandwidth of $(C+Ku)/(C+Ku+Ka)$
- To reflect potential emergence of ISDN, the "low" case assumes no analog, and the "medium" case is biased somewhat toward fewer analog users

2.4.3 Summary of Ground Station Users

Table 9 summarizes the projected number of ground station users for low, medium, and high estimates.

3.0 CANDIDATE CONCEPTS

Task 2 of this study addressed the various concepts for the implementation of the Analog-to-Digital (A/D) conversion of the uplink analog signals and the associated processing on-board the satellite system. It also addressed the concepts of implementation of the associated digital-to-analog conversion of the analog down-links.

The following subsections describe the approach taken. The main objectives of Task 2 are first derived. Then, the various candidate concepts for the implementations of analog-to-digital conversion and the associated on-board processing are developed. Implementation alternatives and the associated issues are discussed. For each of the concepts, the timing and control requirements are identified. The possible component configurations are also identified for each approach, following which, the approach that is best suited, is recommended. Then, the concepts of implementations of Digital-to-Analog (D/A) conversion are described.

3.1 Objectives

The main objectives of task 2 are:

- to develop alternative concepts for implementing the analog-to-digital conversion of the uplink analog signals
- to investigate the associated on-board processing required
- to analyze the timing and control requirements for each of the concepts
- to provide the cost vs performance comparisons
- to rank the alternatives and recommend the approach best suited for the specific application
- to develop concepts for the implementation of the associated down-link digital-to-analog (D/A) conversion

3.2 Concepts for Analog-to-Digital (A/D) Conversion

In this subtask, various approaches for implementation of the A/D conversion of the uplink analog signals are discussed.

There are two fundamental approaches that are distinguished from each other by the nature of implementing the A/D conversion either prior to or after separating the sub-channel accesses .

3.2.1 Concept 1 - Analog Filtering Approach

The first approach separates the sub-channel accesses prior to the A/D conversion of the signals and is called the "Analog Filtering Approach". A simplified block diagram of this implementation concept is shown in Figure 3.

The uplink received analog signals are passed through a Low Noise Amplifier (LNA) and the first stage of receive RF section, which down converts the received uplink signals. It consists of a mixer, a low-pass filter and, an RF de-multiplexer, which separates the individual transponder-channels.

The second stage of receiver's RF section down-converts the individual transponder-channel outputs of the first stage further to an Intermediate Frequency (IF), where the individual sub-channel accesses are separated by means of an IF demultiplexer. Each output of the IF demultiplexer passes through a switchable demodulator, which may be required for accommodating incompatible modulation-demodulation formats on various links.

The output of each switchable demodulator is then passed through the A/D converter. The output of the A/D converter is passed through the switching and routing system, which switches the signal to the appropriate downlink, Inter-Satellite Link (ISL) or the CONTinental United States (CONUS) processor.

3.2.1.1. Implementation of IF Demultiplexer

The IF demultiplexer shown in Figure 4 is comprised of a bank of band-pass filters (BPF) and a filter-selector which selects and switches the appropriate configuration of the BPFs for a given set of transponder sub-channel access configurations.

The bank of BPFs can be implemented by means of a set of BPFs with remotely tunable passband, programmable BPFs or by means of a set of fixed passband switchable BPFs.

For the specific case, when the Intermediate Center Frequency of 70 MHz of the transponder channel of bandwidth 36 MHz, with a minimum subchannel access size of 1 MHz and a maximum access-size of 6 MHz, a possible implementation with a set of fixed passband Surface Acoustic Wave (SAW) Band Pass Filters is illustrated in Figure 5. Current state of the art of technology allows the entire filter bank with the filter-selector, the associated timing and control circuitry included, to be placed on one small Printed Circuit Board (PCB). The programmable passband remotely tunable filter approach, however is still not feasible with the current state of the art devices for applications requiring more than 1 to 2 MHz access-sizes.

3.2.1.2 Implementation of Switchable Demodulator and A/D

During Task 2, a switchable demodulator was included to provide a capability to interface with different modulation types or the Ka-band baseband processor. Upon further study and refinement during Task 3, it was deemed that this approach was not viable, as it would require

demultiplexing to the circuit level or an equivalent transmux function. This amount of processing would be very large, and the capability provided was beyond the scope of this study. This meant that U.S. - Latin American/Caribbean traffic could not be routed to the baseband processor, as originally envisioned in the CPPD study. Rather, this traffic was handled by C and Ku band transponders using FDMA/FM.

3.2.1.3 Timing and Control Requirements for Concept 1

Timing and control for this analog filtering approach are required, for at least the following functional implementations:

- i. For filter configuration, selection and switching
- ii. For programmable passband filter control for the case when the IF demux is implemented with tunable passband programmable filter bank
- iii. For the demodulator switching and its control
- iv. Sampling frequency generation for A/D
- v. For providing the data and control interface for switching and routing system

3.2.2 Concept 2 - Digital Filtering Approach

This approach differs from the previous approach in the order of A/D conversion and access-separation. In this approach, the A/D conversion is performed prior to the digital filtering of the IF input-signal, for separating the different accesses of the transponder channel, as shown in Figure 6.

The IF input-signal passes through the A/D, where the analog signal is digitized and then passes through the Digital Filter Processor (DFP) bank in order for the subchannel accesses to be separated. The outputs of the DFPs are passed through the switchable digital-demodulators, which may be required for transmission on different links with incompatible modulation formats. The outputs of the switchable demodulators are then fed to the switching routing system for further processing and routing to the appropriate downlink or ISL-link processor.

3.2.2.1 Implementations of Digital Filter Bank

The DFP bank can be implemented in two basic approaches:

- i. Time Domain Processing
- ii. Frequency Domain Processing

3.2.2.1.1 Time Domain Processing

There are at least two ways of implementing the DFPs in time domain -- the so called Finite Impulse Response (FIR) filter processors using Very High Speed Integrated Circuits (VHSICs), or the convolvers using either VHSICs or SAW devices.

3.2.2.1.2 Frequency Domain Processing

DSP implementations using Frequency Domain Processing approach can again be performed in at least two ways -- the so called the Fast Fourier Transform (FFT) implementations with VHSICs, or the Chirp Z-Transform (CZT) implementations, using the SAW devices.

3.2.2.1.3 State of the Art of DSP Implementations

Tables 10 and 11 show the current (1986) and projected (1993) state of the art of signal processing functions that can be embodied in a single chip. The projections for 1993 state of the art are needed because of the assumptions that the launch of the payload is going to be in 1998 and that a five year lead time is needed for the availability of fully tested and flight-qualified parts.

It should be first mentioned that a 36 MHz transponder channel requires a minimum of 72 MHz sampling rate. Typically, a sampling rate of 90 to 100 MHz is desirable. From these two tables, it is easy to see that single chip implementations of both A/D and D/A are currently available that meet this requirement. No information is available at this point on the the implementation of DSPs with CZT approaches. The FFT approaches of the DFP implementations meeting the requirement of 100 MHz rates are expected to be available in 1993. The current state-of-the-art single chip implementations can support only up to rates of 10 MHz, which is an order of magnitude below the 1993 requirement. The time-domain approaches of DFP implementations, supporting 100 MHz sampling rates, may not be available even in 1993.

3.2.2.1.4 Implementation of DFPs with FFT Approach

From the discussion of the previous section, it can be concluded that the only viable DFP implementation for this application seems to be via the FFT approach. An illustration of the implementation of the DSP bank with the FFTs is shown in Figure 7.

In the FFT approach, the digital signal at the output of the A/D is buffered and passed to an FFT machine, where the spectrum of the input signal is computed. The spectral output of the FFT machine is then passed to the Spectral Sample Memory (SSM), from which the various transponder subchannel accesses are separated by selecting the appropriate parts of the SSM. The spectral samples of the subchannel accesses are then passed through the bank of Inverse Discrete Fourier Transform (IDFT) computers, providing the subchannel access signals in the time-domain, which are then forwarded to the Switching and Routing System.

3.2.2.2 Timing and Control Requirements for DFP Approach

The timing and control requirements for the illustrated implementation of the DFP Approach are given below:

- i. Sampling frequency generation
- ii. DFP timing and control, which includes the buffer memory and FFT timing and control functions.
- iii. Spectral sample memory timing, window-selection, processing and control functions.
- iv. IDFT configuration, selection, timing and control

- v. Demodulator's switching, timing and control
- vi. Timing, control and data interface for interfacing with the switching and routing system.

3.2.3 Switching and Routing System

The digital Switching and Routing System (Figure 8) facilitates the communication paths between the uplink and the appropriate downlink accesses. The digital subchannel access signals are inputted into the appropriate access input memory buffers. The digital switch, operating under the control of the digital routing controller, facilitates the communication paths between the input and the appropriate output access-memory-buffers. The outputs of the access-output-memories are passed to the appropriate transmit subsystems.

3.3 Comparison of A/D Approaches and Recommendations

The two main concepts of implementations of A/D conversion schemes -- the analog filtering approach and the digital filtering approach -- are compared in this subsection both qualitatively and quantitatively, leading directly to the recommended approach.

3.3.1 Qualitative Comparison

Table 12 shows a qualitative comparison between the analog and digital filtering approaches. The complexity of implementation of each of the functions listed is rated low, moderate or high with the current(1986) and the projected 1993 state-of-the-art parts.

This table shows that the analog filtering approach with switchable fixed passband filter bank is implementable with low complexity, even with the current state-of-the-art parts. The remotely programmable passband filter bank, on the other hand, is very difficult to implement with the current state-of-the-art parts, and is not expected to be easily implementable even with 1993 state-of-the-art parts.

The digital filtering approach requires timing and control functions with very high complexity of implementation using currently available parts. Even in 1993, this function does not seem to be very easily implementable.

3.3.2 Quantitative Comparison

Tables 13 and 14 show the power, size, weight and cost estimates with the current and 1993 state-of-the-art parts for the analog filtering and digital filtering approaches respectively. This comparison is on the basis of one 36 MHz transponder channel. The costing estimates are based on the off-the-shelf component availability. No flight-hardware certification or other Non-Recurring-Expenditures (NRE) are considered.

These tables clearly show that the analog filtering approach with switchable fixed passband SAW filter-bank has lower power requirements, size, weight and costs compared with the digital filtering approach even with the projected 1993 state-of-the-art technologies (such as Gallium Arsenide) and parts.

3.3.3 Recommendations

From the qualitative and quantitative comparisons presented here, it is clear that the analog filtering approach with switchable fixed passband SAW bandpass filterbank is superior to the other implementation approaches. This implementation utilizes parts (such as SAW filters and relatively lower speed A/D converter devices) with proven and mature technology. This approach is overall the simplest of all the implementations considered here, provides compact size, and has both low power and timing & control requirements.

Since this approach provides overall superior performance and utilizes parts with proven mature technology, the analog filtering approach using switchable fixed passband SAW bandpass filter bank is recommended for implementation of the A/D on-board the satellite system.

3.4 Concepts for Digital to Analog (D/A) Conversion

The analog downlinks require Digital-to-Analog (D/A) conversion of the digital subchannel access-signals. This is accomplished by the introduction of a D/A converter prior to analog modulation and downlink upconversion as shown in the block-diagram, Figure 9.

The digital output stream of the downlink transponder signals from the switching and routing system passes through the high speed D/A converter, whose output analog signal is demultiplexed for forwarding to the switchable analog subchannel access modulators and, to the downlink upconverters

The high-speed D/A (up to 200MHz rates) converters are implementable with the current state-of-the-art single chip converters quite easily.

3.5 Summary of Task 2

Various alternative concepts of implementation of onboard A/D conversion of the analog uplink signals and the associated onboard processing, timing and control requirements are investigated in this task. The component identification for each concept is also performed in this task. The analog filtering approach with switchable fixed passband SAW filter banks and high-speed flash A/D converters is recommended because of the overall superior performance of this approach. Concepts of implementation of the associated D/A conversion for the analog downlink processing are also presented.

4.0 IMPACT ANALYSIS

The architecture selected from the candidate concepts discussed in Section 3 was the analog, switched filter approach. In this section, economic comparisons are made between this concept and the situation where no on-board A/D processing is used and changes are required on the ground as well as the spacecraft.

4.1 International

4.1.1 Options

Figures 10 and 11 present the two basic architectures considered - with and without A/D conversion. In the A/D case, no changes are required on the ground. On the spacecraft the following hardware is added between the usual input receiver/MUX (i.e., at a 36 MHz level) and the output MUX:

- Local oscillator to bring signal to IF
- Switched filter bank
- A/D converter
- Digital switch
- D/A converter
- MUX to 36 MHz level
- Upconverter to RF

In Figure 11, the ground station must be modified to convert incoming analog circuits to digital by means of back-to-back analog and digital channel banks, or by a transmux. Also, digital multiplexing equipment (M12 and M13) is required, as well as a change of the modulator to a digital mode such as QPSK. The satellite also requires modification similar to the above list, except the A/D and D/A equipment is replaced by a QPSK modem.

Because the demod output in Figure 11 is at baseband, the data rates for the different access sizes are lower than in Figure 10, where the A/D conversion is performed on the modulated signal, thus requiring a higher sampling rate. The digital switch is therefore smaller in the no A/D case, but other costs, particularly for the ground stations, are much higher as described subsequently.

4.1.2 Satellite Cost Assumptions

4.1.2.1 Space Qualification

Individual parts used in satellite applications must be subjected to certain testing to ensure high reliability. These tests include inspection of construction quality, centrifuge tests, high temperature burn-in, etc. Assembled items, such as circuit cards also require testing. We have assumed the following costs:

- \$20,000 per part
- \$15,000 per assembly

4.1.2.2 Development Costs

All development costs, except for the digital switch, are based on packaging design. These costs vary from 0 to \$40,000, as indicated in Table 15.

There are currently digital switches under development for satellite use, i.e., the ACTS BBP and MILSTAR. However, the former is designed for individual circuits at 64 Kbs, and the latter uses even lower data rates. Counterbalancing the higher total throughput required by our application is the fact that terminal synchronization is not required; all synchronization, timing, and framing is done on board. Therefore, data frames can be much shorter than when terminal to satellite timing must be considered. This reduces the "size" (buffer requirements) of the switch, but also increases the processing throughput required. A parallel architecture would probably be the best approach.

As pointed out in Section 4.1.1, the data rates input to the switch depend on whether A/D is performed on board or not. The former case requires a larger switch for the same number of circuits. The following assumptions were used for the large switch :

Development effort	10 man years
Hours/year	1760
Loaded labor/hour	\$70
Total development cost	<u>\$1,230,000</u>

The "small" switch is assumed to require 7 man years, so the cost is \$862,000.

4.1.2.3 Payload Mass, Power, and Recurring Costs

See Section 3.3.2.

4.1.2.4 Total Number of Transponders Requiring A/D

The CPPD study developed the number of transponders required for Latin America/Caribbean, i.e., twenty-seven 36 MHz transponders. In order to extrapolate these results to include the U.S. as well, the number of transponders was increased to allow for the U.S. international requirements (147K circuits) as well:

$$93 \text{ transponders} = 27 \text{ transponders} \times (60.2 + 147)/60.2$$

4.1.2.5 Integration and Test

These costs were assumed to be 8% of the recurring costs. The CPPD study showed a range of 6% to 10% for the integration and test, so an average of 8% was applied.

4.1.2.6 Power Effects

The additional power requirements result in not only a direct cost for solar arrays and batteries, but an indirect cost for launch (see next section) for the increased mass of power equipment. The direct costs are assumed to \$1M per KW, and the additional mass is obtained from Figure 12, using the "total power for 100% eclipse" curve. This curve is developed in the Ford Aerospace Platform Bus Study, Ref [3].

4.1.2.7 Launch Costs

Launch Costs were calculated on an incremental basis, allowing for additional mass for payload, fuel, and power equipment. The basic formula is from the Rockwell study on launch costs, Ref [4], which is

$$(\$M) = 44.6 \times \ln(\text{BOL-lbs}) - 293.2$$

This can be converted to an incremental increase in launch costs by assuming an initial satellite mass of BOL and an increase of "d", i.e.,

$$(\$M) = 44.6 \times \ln((\text{BOL}+d)/\text{BOL})$$

The baseline mass used is 21404 lbs, derived as follows from the CPPD study:

- International BBP deleted (184 Kg)
- 3200 Kg payload mass
- 31% of BOL is payload

Thus, the baseline BOL value is

$$21404 \text{ lbs} = 2.2 \times (3200 - 184)/.31$$

Other values for BOL will be considered in Sections 4.2.2.5 and 4.3.

4.1.2.8 Bandwidth Efficiency

A penalty has been assigned to the use of digital modulation, reflected as an increased number of transponders required on the satellite. A level 1 analog access (1.44 MHz) contains 96 equivalent voice grade circuits; for a digital signal, it is assumed only 90 circuits can be carried in the same bandwidth, based on the following:

- 1.5 bits/Hz
- 24 Kb/s per voice channel (see Ref [2])

The total number of transponders is thus $99 = 93 \times (96/90)$.

4.1.3 Earth Station Cost Assumptions

If on-board satellite A/D and D/A conversion is not available, then analog traffic to/from earth stations must be converted into digital traffic because of the assumption that any ISL will utilize digital modulation. This applies to a laser ISL as well as a W-band ISL. This conversion is to be realized (1) at the terrestrial interface between the earth station and terrestrial lines, and (2) at the interface of the earth station and the RF link.

Terrestrial interface is required only if the terrestrial lines are analog. By year 2008 it is assumed that only 50% of those lines are analog and the terrestrial interface will be costed accordingly. Conversion analog/digital for voice is achieved either with the channel bank or the transmux, converting 24 voice channels into standard digital format DS-1 of 1.544 Mbits. The DS-1 signal is then multiplexed into DS-2 signal of 6.312 Mbits (96 channels) and DS-2 to DS-3 of 46.304 Mbits (672 channels). The 96 channel DS-2 capacity is equivalent to level 1 (1.44 MHz) and the 672 channel DS-3 to about 2 times level 2 (7.2MHz) or 25% of level 3 (36 MHz) of the solution using on-board A/D.

RF link interface at the earth station is achieved by PSK modem driven either by DS-2, DS-3 or multiple DS-3 signals with FDMA or TDMA access mode. TDMA mode seems not practicable due to the high cost of adding TDMA operation to an FDM operated earth station and the difficulty in synchronization of great number of earth stations specially through intersatellite link. Access mode such as QPSK/FDMA seems the most feasible and the cost of RF interface at the station is limited to the QPSK modem (with or without FEC). The FDMA access mode requires that to each terrestrial PSK modem should correspond the same functional equivalent modem on the satellite. On the satellite, the modem demodulates the uplink signal to DS-2 or DS-3 formats; such formats are then not demultiplexed to DS-1 or 64 Kbits but routed as is through International Routing Switch #2 for PSK modulation to the downlink.

The channel bank or transmux and the digital multiplex (DS-1 to DS-2 and DS-2 to DS-3) are well established technology, extensively used in terrestrial network with very stable price. The QPSK modem for standard DS-2/DS-3 signal is currently available and expected to be well established by year 2000.

The following are estimated recurrent cost per installed circuit for one end (i.e. originating + terminating in the earth station at one end of the communication link). Price is quoted by NEC for year 2000.

Channel bank or transmux	\$160/circuit
DS-2 or DS-3 mux	\$69/circuit
QPSK modem with FEC	\$7/circuit

4.1.4 Summary of International

Tables 15 through 17 summarize the various items listed above and provide a final bottom line comparison. The satellite costs are very close in both architectures, but the earth station costs dominate in the design with no A/D conversion on-board. The basic reason these costs are so large is that when A/D is done at the terrestrial interface, the conversion is at the individual circuit level, either explicitly by use of back-to-back channel banks, or implicitly by means of a transmux, which is itself a fairly large, complex equipment.

In contrast to the recommended design which uses a few SAW filters and ADC chips per 36 MHz transponder, the advantage for on-board conversion is obvious. The disadvantage is that one must pay a penalty in both switch size and ISL capacity due to the higher bit rates involved.

4.1.5 Crossover Analysis

The crossover analysis of Figure 13 shows three curves, each representing the total network cost as a function of the number of 36 MHz transponders for the international case; further parametric analyses are contained in Section 4.3. The curves are of the form $NRE + REC * N$, where N is the number of 36 MHz transponders shown on the abscissa of Figure 13.

1. *Curve A/D*: The earth stations are carrying analog traffic with on-board satellite A/D and D/A conversion. There is no modification required at the earth station and the cost is limited to satellite A/D and D/A conversion. The NRE cost used is obtained from columns C and D of Table 15, less the switch 2 row, for a total of \$1495K. The REC cost per unit (36 MHz) is derived from the A/D total of Table 17, less the NRE, and divided by 93, or \$45.7K per unit.

2. *Curve NO A/D, NO E/S COST*: There is no on-board A/D and D/A conversion. Analog traffic is converted into digital traffic under standard digital format DS-1, DS-2 and DS-3. This requires analog/digital conversion at the earth station. The NRE is obtained from columns C and D of Table 15 for those items applicable to the domestic design, for a total of \$977K. The REC is calculated from the NO A/D column of Table 17, less NRE and earth station costs, and divided by 99 to obtain \$47.6K per unit.

3. *Curve NO A/D, WITH E/S COST*: This is the same as curve 2 above, except that the earth station costs in Table 17 have been included, for a total REC of \$391.3K per unit.

4.2 U.S. Domestic Impacts

4.2.1 Options

Figure 10 still applies for the use of on-board A/D. The other option, used in the CPPD study, is depicted in Figure 14, and represents the additional transponders required when splitting a 36 MHz bandwidth into 2 or 3 channels of 18 or 12 MHz respectively.

4.2.2 Satellite Cost Assumptions

Most of the assumptions used are identical to those in Section 4.1.2; only differences will be covered in the following subsections.

4.2.2.1 Total Number of Transponders Requiring A/D

In this case, there are two 36MHz transponders in each of 9 beams on a total of seven satellites (see CPPD study), for a total of 126 transponders.

4.2.2.2 Switch Costs

Development costs for the small switch described in Section 4.1.2.2 were used, but recurring costs were taken from the large switch design. The reason these assumptions were used is because any one switch on a satellite in the domestic application interfaces with only 18 transponders (considerably less than the international case), but the data rate output from each 36 MHz transponder after A/D is the same as the international situation. Since we have chosen to base recurring costs on a 36 MHz transponder basis, this approach is the most reasonable.

4.2.2.3 Fill Factor Penalties

The fill obtained when using A/D is 90% (see Section 2.4). An analysis of the fill obtained within the 12 and 18 MHz transponders in the CPPD study showed that only an 80% fill was obtained. This is to be expected, as the A/D approach provides smaller access sizes. The number of additional transponders required is calculated as follows:

$$15 \text{ transponders} = 126 \times (.9/.8 - 1)$$

4.2.2.4 Additional Transponders Required for Baseline

In the baseline approach, two 36 MHz channels were converted to a total of two 18 MHz and three 12 MHz channels, each with its own transponder. Hence, there are three additional transponders required in each of nine beams on seven satellites, for a total of 189 which can be eliminated if A/D is used. These are charged against the "no A/D" approach, at a cost of \$172.1K each.

4.2.2.5 Launch Costs

The base BOL weight in this case is based on

- Deletion of 27 transponders @ 3.43 Kg
- 2260 Kg payload mass
- .31% of BOL mass is payload

The BOL is then:

$$15381 \text{ lbs} = 2.2 \times (2260 - 27 \times 3.43)/.31$$

4.2.3 Earth Station Costs

In the U.S. domestic case, there is no forcing requirement for conversion to digital. The CPPD design of providing some narrow band (12 and 18 MHz) transponders was simply one way to provide additional routing flexibility which was essentially transparent to the earth stations. The use of on-board A/D conversion is another way to accomplish the same objective.

4.2.4 Summary of U.S. Domestic

Tables 18 through 20 summarize the U.S. domestic analysis. Here, the dominant cost is the additional transponders required by the baseline design.

4.3 Parametric Analysis

The results presented in Sections 4.1 and 4.2 were derived from large platform designs. In order to investigate the use of A/D conversion in a more conventional situation, two other satellite designs were considered - the INTELSAT-V and INTELSAT-VI. These were chosen because it would make no sense to use A/D for the purpose of improving fill in a design with only CONUS coverage (such as WESTAR or RCA Satcom). Thus, satellites with some degree of spatial reuse were chosen. The improvement in fill was the primary issue in these analyses.

4.3.1 Satellite Cost Assumptions

4.3.1.1 Total Number of Transponders

In order to simplify the analysis relative to the previous sections, it is assumed that the I-V and I-VI use 36 MHz transponders. Although some channels are so configured, the majority are 72 MHz in bandwidth. Also, only the Hemi/Zone beams were considered; the global coverage beam would not use A/D for the same reason as a CONUS beam, as discussed above.

	I-V	I-VI
Number of beams	4	6
#36 MHz xpdrs/beam	9	9
#xpdrs/beam using A/D	2	2
Number of satellites	12	5

4.3.1.2 Switch Costs

The same figures as for U.S. Domestic were used (see Section 4.2.2.2).

4.3.1.3 Fill Factor Penalties

An assumed fill of 65% was used. The penalty is a total (for all satellites) of 36 and 25 transponders for the I-V and I-VI respectively. A cost of \$140K per transponder was assumed.

4.3.1.4 Power and Mass

The assumptions used here are as follows (all masses in lbs):

	I-V	I-VI
BOL	2460	5060
Xpdr mass	13.43	11.61
Xpdr pwr	24.6	24.1
Switch mass	4.8	7.2
Switch pwr	7.8	11.7
Fuel (% of BOL)	21.5	16
Lbs/watt for solar/battery	.18	.2

4.3.1.5 Summary of Parametric Analysis

Tables 21 through 23 show the results for the I-V, and Tables 24 through 26 cover the I-VI. As can be seen, the A/D approach is *not* the preferred approach. The reason for this is that in each of the previous two analyses, there was a major cost driver which is not present here, namely the terrestrial interface costs in the international case, and the large number of additional narrow band transponders (12 and 18 MHz) used in the U.S. Domestic case.

5.0 CONCLUSIONS AND RECOMMENDATIONS

It appears that A/D processing on board a satellite provides advantages when digital routing on board is absolutely required, as in the case of a digital ISL. The use of A/D would also provide advantages in improving fills in some situations. For example, several beam-to-beam demands among the small spot beams used in the CPPD study in Latin America only had 19 circuits, which would have resulted in near-zero fills for a 36 MHz transponder. However, the approach does not seem to offer any advantages for satellite coverage designs with a lower reuse, plus overlapping beams, i.e., the INTELSAT Hemi beams cover one or more zone beams, thus offering improved fills relative to independent, non-overlapping spot beams.

It appears that A/D conversion can be obtained with technology that either exists today, or would need only modest development. The area of greatest uncertainty is the high speed digital switch, which is different than the ACTS baseband processor.

Also, a more complete analysis of how the A/D conversion would affect performance relative to CCITT or other standards would need to be performed before any final implementation.

REFERENCES

- [1] "Communication Platform Payload Definition Study Final Report," Vols 1-3, E.M. Hunter, T.F. Driggers, and R. Jorasch, Ford Aerospace and Communications Corporation, March, 1986
- [2] "Demand For Satellite-Provided Domestic Communications Services to the Year 2000," NASA TM 86894, S. Stevenson, W. Poley, J Lekan, and J. Salzman, Lewis Research Center, November, 1984
- [3] "Geostationary Platform Bus Study Final Report, " Vol II, Ford Aerospace and Communications Corporation, September, 1986
- [4] "Space Platform Expendables Resupply Concept Definition Study," Vols I & II, Rockwell International, NASA STS 85-0174, March-December, 1984

Appendix A
ACCESS SIZE SAMPLE RESULTS

The printouts included in this appendix are a subset from the program used to derive the curves of Figure 1. Only the results for a minimum fill of 70% are included.

A/D FILL RESULTS

Parameters for this run:
Minimum Fill - 0.70
Capacity of 36 Mhz - 2400

* Circuits at level 1 : 12 Circuits at level 2 : 192
Level 1 Qty : 294 Level 2 Qty : 134 Level 3 Qty : 14
Total Qty : 442 Average Fill : 0.958

* Circuits at level 1 : 12 Circuits at level 2 : 276
Level 1 Qty : 534 Level 2 Qty : 82 Level 3 Qty : 14
Total Qty : 630 Average Fill : 0.962

* Circuits at level 1 : 12 Circuits at level 2 : 360
Level 1 Qty : 572 Level 2 Qty : 62 Level 3 Qty : 14
Total Qty : 648 Average Fill : 0.959

* Circuits at level 1 : 12 Circuits at level 2 : 444
Level 1 Qty : 711 Level 2 Qty : 48 Level 3 Qty : 14
Total Qty : 773 Average Fill : 0.949

* Circuits at level 1 : 12 Circuits at level 2 : 528
Level 1 Qty : 1011 Level 2 Qty : 33 Level 3 Qty : 14
Total Qty : 1058 Average Fill : 0.954

* Circuits at level 1 : 12 Circuits at level 2 : 612
Level 1 Qty : 1271 Level 2 Qty : 23 Level 3 Qty : 14
Total Qty : 1308 Average Fill : 0.957

* Circuits at level 1 : 12 Circuits at level 2 : 696
Level 1 Qty : 1367 Level 2 Qty : 18 Level 3 Qty : 14
Total Qty : 1399 Average Fill : 0.963

* Circuits at level 1 : 24 Circuits at level 2 : 192
Level 1 Qty : 158 Level 2 Qty : 134 Level 3 Qty : 14
Total Qty : 306 Average Fill : 0.954

* Circuits at level 1 : 24 Circuits at level 2 : 288
Level 1 Qty : 261 Level 2 Qty : 81 Level 3 Qty : 14
Total Qty : 356 Average Fill : 0.953

* Circuits at level 1 : 24 Circuits at level 2 : 384
Level 1 Qty : 294 Level 2 Qty : 59 Level 3 Qty : 14
Total Qty : 367 Average Fill : 0.951

* Circuits at level 1 : 24 Circuits at level 2 : 480
Level 1 Qty : 389 Level 2 Qty : 44 Level 3 Qty : 14
Total Qty : 447 Average Fill : 0.940

* Circuits at level 1 : 24 Circuits at level 2 : 576
Level 1 Qty : 577 Level 2 Qty : 28 Level 3 Qty : 14
Total Qty : 619 Average Fill : 0.947

* Circuits at level 1 : 24 Circuits at level 2 : 672
Level 1 Qty : 689 Level 2 Qty : 19 Level 3 Qty : 14
Total Qty : 722 Average Fill : 0.958

* Circuits at level 1 : 36 Circuits at level 2 : 180
Level 1 Qty : 117 Level 2 Qty : 142 Level 3 Qty : 14
Total Qty : 273 Average Fill : 0.951

* Circuits at level 1 : 36 Circuits at level 2 : 288

Level 1 Qty : 191 Level 2 Qty : 81 Level 3 Qty : 14
Total Qty : 286 Average Fill : 0.944

* Circuits at level 1 : 36 Circuits at level 2 : 396
Level 1 Qty : 224 Level 2 Qty : 14 Level 3 Qty : 14
Total Qty : 294 Average Fill : 0.944

* Circuits at level 1 : 36 Circuits at level 2 : 504
Level 1 Qty : 292 Level 2 Qty : 41 Level 3 Qty : 14
Total Qty : 347 Average Fill : 0.930

* Circuits at level 1 : 36 Circuits at level 2 : 612
Level 1 Qty : 449 Level 2 Qty : 23 Level 3 Qty : 14
Total Qty : 486 Average Fill : 0.944

23 * Circuits at level 1 : 36 Circuits at level 2 : 720
Level 1 Qty : 475 Level 2 Qty : 18 Level 3 Qty : 14
Total Qty : 507 Average Fill : 0.946

* Circuits at level 1 : 48 Circuits at level 2 : 192
Level 1 Qty : 94 Level 2 Qty : 134 Level 3 Qty : 14
Total Qty : 242 Average Fill : 0.944

* Circuits at level 1 : 48 Circuits at level 2 : 288
Level 1 Qty : 150 Level 2 Qty : 81 Level 3 Qty : 14
Total Qty : 245 Average Fill : 0.939

* Circuits at level 1 : 48 Circuits at level 2 : 384
Level 1 Qty : 164 Level 2 Qty : 59 Level 3 Qty : 14
Total Qty : 237 Average Fill : 0.939

* Circuits at level 1 : 48 Circuits at level 2 : 480
Level 1 Qty : 210 Level 2 Qty : 44 Level 3 Qty : 14
Total Qty : 268 Average Fill : 0.930

* Circuits at level 1 : 48 Circuits at level 2 : 576
Level 1 Qty : 310 Level 2 Qty : 28 Level 3 Qty : 14
Total Qty : 352 Average Fill : 0.932

* Circuits at level 1 : 48 Circuits at level 2 : 672
Level 1 Qty : 367 Level 2 Qty : 19 Level 3 Qty : 14
Total Qty : 400 Average Fill : 0.941

* Circuits at level 1 : 60 Circuits at level 2 : 180
Level 1 Qty : 75 Level 2 Qty : 142 Level 3 Qty : 14
Total Qty : 231 Average Fill : 0.946

* Circuits at level 1 : 60 Circuits at level 2 : 300
Level 1 Qty : 141 Level 2 Qty : 73 Level 3 Qty : 14
Total Qty : 228 Average Fill : 0.942

* Circuits at level 1 : 60 Circuits at level 2 : 420
Level 1 Qty : 140 Level 2 Qty : 54 Level 3 Qty : 14
Total Qty : 208 Average Fill : 0.931

* Circuits at level 1 : 60 Circuits at level 2 : 540
Level 1 Qty : 222 Level 2 Qty : 33 Level 3 Qty : 14
Total Qty : 269 Average Fill : 0.930

* Circuits at level 1 : 60 Circuits at level 2 : 660
Level 1 Qty : 290 Level 2 Qty : 20 Level 3 Qty : 14
Total Qty : 324 Average Fill : 0.938

* Circuits at level 1 : 60 Circuits at level 2 : 780
Level 1 Qty : 302 Level 2 Qty : 16 Level 3 Qty : 14
Total Qty : 332 Average Fill : 0.938

* Circuits at level 1 : 72 Circuits at level 2 : 144
Level 1 Qty : 61 Level 2 Qty : 182 Level 3 Qty : 14
Total Qty : 257 Average Fill : 0.938

* Circuits at level 1 : 72 Circuits at level 2 : 288
Level 1 Qty : 108 Level 2 Qty : 81 Level 3 Qty : 14
Total Qty : 203 Average Fill : 0.931

* Circuits at level 1 : 72 Circuits at level 2 : 432
Level 1 Qty : 149 Level 2 Qty : 48 Level 3 Qty : 14
Total Qty : 211 Average Fill : 0.926

* Circuits at level 1 : 72 Circuits at level 2 : 576
Level 1 Qty : 214 Level 2 Qty : 28 Level 3 Qty : 14
Total Qty : 256 Average Fill : 0.925

* Circuits at level 1 : 72 Circuits at level 2 : 720
Level 1 Qty : 251 Level 2 Qty : 18 Level 3 Qty : 14
Total Qty : 283 Average Fill : 0.932

* Circuits at level 1 : 84 Circuits at level 2 : 168
Level 1 Qty : 70 Level 2 Qty : 152 Level 3 Qty : 14
Total Qty : 236 Average Fill : 0.927

* Circuits at level 1 : 84 Circuits at level 2 : 252
Level 1 Qty : 110 Level 2 Qty : 88 Level 3 Qty : 14
Total Qty : 212 Average Fill : 0.927

* Circuits at level 1 : 84 Circuits at level 2 : 336
Level 1 Qty : 122 Level 2 Qty : 63 Level 3 Qty : 14
Total Qty : 199 Average Fill : 0.927

* Circuits at level 1 : 84 Circuits at level 2 : 420

Level 1 Qty : 113 Level 2 Qty : 54 Level 3 Qty : 14
Total Qty : 181 Average Fill : 0.916

* Circuits at level 1 : 84 Circuits at level 2 : 504
Level 1 Qty : 143 Level 2 Qty : 41 Level 3 Qty : 14
Total Qty : 198 Average Fill : 0.909

* Circuits at level 1 : 84 Circuits at level 2 : 588
Level 1 Qty : 216 Level 2 Qty : 23 Level 3 Qty : 14
Total Qty : 253 Average Fill : 0.923

* Circuits at level 1 : 84 Circuits at level 2 : 672
Level 1 Qty : 226 Level 2 Qty : 19 Level 3 Qty : 14
Total Qty : 259 Average Fill : 0.922

* Circuits at level 1 : 96 Circuits at level 2 : 192
Level 1 Qty : 70 Level 2 Qty : 134 Level 3 Qty : 14
Total Qty : 218 Average Fill : 0.912

* Circuits at level 1 : 96 Circuits at level 2 : 288
Level 1 Qty : 95 Level 2 Qty : 81 Level 3 Qty : 14
Total Qty : 190 Average Fill : 0.912

* Circuits at level 1 : 96 Circuits at level 2 : 384
Level 1 Qty : 105 Level 2 Qty : 59 Level 3 Qty : 14
Total Qty : 178 Average Fill : 0.908

* Circuits at level 1 : 96 Circuits at level 2 : 480
Level 1 Qty : 126 Level 2 Qty : 44 Level 3 Qty : 14
Total Qty : 184 Average Fill : 0.902

* Circuits at level 1 : 96 Circuits at level 2 : 576
Level 1 Qty : 177 Level 2 Qty : 28 Level 3 Qty : 14
Total Qty : 219 Average Fill : 0.903

* Circuits at level 1 : 96 Circuits at level 2 : 672
Level 1 Qty : 208 Level 2 Qty : 19 Level 3 Qty : 14
Total Qty : 241 Average Fill : 0.908

Appendix B BIBLIOGRAPHY

Papers/Articles:

1. E. Stern, "Comparison of New Analog Device Technologies for Signal Processing," IEEE 1983 Ultrasonics Symposium Record, pp. 129-136.
2. J. Roberts, P. Simpson and B. Merrifield, "Applying Digital VLSI Technology to Radar Signal Processing," Microwave Journal, January 1986, pp. 129-144.
3. R. Cushman, "Digitization is on the way for FFT designs," EDN August 5 1981, pp. 99-106.
4. P. Greiling, "The Future Impact of GaAs Digital IC's," IEEE Journal on Selected Areas in Communications, vol. SAC-3, no. 2, March 1985, pp. 384-393.
5. DSP Associates "DSP-Chip Comparison Chart" prepared for EE Times
6. W. Sullivan, "Ultra-Wideband IFM Receiver Fulfills Design Requirements," MSN &CT April 1985, pp. 105-105.
7. M. Jack, P. Grant and J. Collins, "The Theory, Design, and Applications of Surface Acoustic Wave Fourier-Transform Processors," Proceedings of the IEEE, vol. 68, no. 4, April 1980, pp. 450-468.
8. J. Maines and E. Paige, "Surface-Acoustic-Wave Devices for Signal Processing Applications," Proceedings of the IEEE, vol. 64, no. 5, May 1976, pp. 639-652.
9. R. Hays and C. Hartmann, "Surface-Acoustic-Wave Devices for Communications," Proceedings of the IEEE, vol. 64, no. 5, May 1976, pp. 652-671.

A/D Devices:

1. Analog Devices AD5010KD Data Sheet
2. Siemens SDA5200 Data Sheet
3. Sony CX20116 Data Sheet
4. TRW TDC1029 Data Sheet

D/A Devices:

1. Analog Devices AD9700 Data Sheet
2. Honeywell HDAC-97000 Data Sheet

3. Intech VDAC-0805 Data Sheet
4. Sony CX20201 Data Sheet
5. TRW TDC1018 Data Sheet

DSP VHSIC Devices:

1. TRW TDC1028 Data Sheet
2. Zoran ZR33481 Data Sheet
3. Zoran ZR33881 Data Sheet
4. Zoran DSP Products Catalog

Digital IFM Receivers:

1. NSL-1050/1052/1054 Modular Digital IF Receivers-- General Instrument NSL1050 Series IFM Receiver Product Bulletin.
2. NSL-1040/1042/1044 Digital Frequency Discriminators -- General Instrument NSL1040 Series DFDs Product Bulletin.

Tunable (Programmable Passband) Analog Filters

1. RF Products Inc. Remotely Tuned/ Manual Tuned/ Frequency Agile Communication Filters Brochure.
2. Tektron Micro Electronics Inc. Remotely Programmed Filter Set Brochure.

Fixed Passband Analog Filter Banks

1. CTI-260 Surface Acoustic Wave Filter Bank -- Crystal Technology Data Sheet and application notes.
2. Raytheon SAW Components Catalog
3. Anderson Laboratories Signal Processing Devices & Components Catalog

Table 1
INTERNATIONAL SUMMARY OF COSTS

	A/D	NO A/D
EARTH STATION	-	34026
PAYLOAD (NRE + REC)	2443	2429
POWER	1196	1227
LAUNCH (P/L + POWER + FUEL)	2103	2029
TOTAL	\$5.7M	\$39.7M

NOTE*
COSTS IN \$(000), EXCEPT TOTALS.

Table 2
U.S. DOMESTIC SUMMARY OF COSTS

	A/D	NO A/D
PAYLOAD (NRE + REC)	2433.1	35116.2
POWER	1634.5	1952.3
LAUNCH (P/L + POWER + FUEL)	4067	6291
TOTAL	\$8.13M	\$43.4M

NOTES

COSTS IN \$ (000), EXCEPT TOTALS

LAUNCH COSTS CALCULATED FOR SINGLE
 SATELLITE AND MULTIPLIED BY SEVEN

TABLE 3
FLASH A/D CONVERTER COMPARISONS

SUPPLIER	MODEL	RESOLUTION (BITS)	INPUT RANGE	SAMPLING FREQ (MHz)	MAX INPUT FREQ. (1) (MHz)	SUPPLIES (V)	POWER (W)	LINEARITY	PACKAGED	PRICE	REMARKS
ANALOG DEVICE	AD5010KD	6	±2.5V	100	40	-5.2V	0.45	+1/2 LSB	16 PIN DIP		ECL
FERRANTI	ZN440	6	0 TO -1V	18	8.2	+5V	0.7	+1 LSB MAX	24-PIN DOUBLE PIN	\$58.23 (100)	OPEN COLLECTOR OUTPUTS
FERRANTI	ZN441	6	0 TO -1V	10	4	+5V	1	+1/2 LSB MAX	24-PIN DOUBLE PIN	\$46.60 (100)	OPEN COLLECTOR OUTPUTS
MOTOROLA	MC10315/ 10317 (3)	7	1VPP	15	8	+5V -5.2V	1.1	+1 LSB MAX	24-PIN DOUBLE PIN	\$79 (100)	ECL SPEC 500-FPM AIR FLOW (COOLING) EVALUATION BOARDS AVAIL
FCA	CA3300D	6	2.4V MIN. SUPPLY MAX	15	7.5	5 TO 8V	0.15	+0.8 LSB MAX	18-PIN DIP	\$38 (100)	CMOSSOS 3-STATE OUTPUTS
FCA	CA3308D	8	4 TO 8V	15	7.6	4 TO 8V	0.24	+1 LSB MAX	24-PIN DOUBLE PIN	\$113 (1000)	CMOSSOS 3-STATE OUTPUTS
SIEMENS	SDA6020 (4)	6	±2.5V	50	25	+5V -5.2V	0.45	+1/4 LSB MAX	16 PIN DIP	\$58.35 (100)	ECL NEEDS 100 PULL DOWNS
SIEMENS	SDA5200 (4)	6	±2.5V	100	31.6	+5V -5.2V	0.56	+1/4 LSB MAX	16 PIN	\$138 (100)	ECL NEEDS 100 PULL DOWNS

TABLE 4
FLASH A/D CONVERTER COMPARISONS
(CONT'D)

SUPPLIER	MODEL	RESOLUTION (BITS)	INPUT RANGE	SAMPLING FREQ (MHZ)	MAX INPUT FREQ (1)	SUPPLIES (V)	POWER (W)	LINEARITY	PACKAGED	PRICE	REMARKS
SONY	CX20116	8	0.5 TO -7V MAX.	100	40	-5.2V	1.2	+ 1/2 LSB	42 PIN DIP	\$640 (100)	ECL AVAILABLE IN EXT.D. TEMP RANGE) EVALUATION BOARD AVAILABLE
TELMOS	TML1070	7	±3.2V	8	4	+5.5V	0.1	+ 1 LSB MAX	24 PIN DOUBLE DIP	\$64.43 (100)	CMOS NEEDS EXTERNAL PULL-UPS
TELMOS	TML1072	7	±3.2V	1	9.5	+5V	0.009	+ 1 LSB MAX	24 PIN DOUBLE DIP	\$64.43 (100)	LOWEST POWER FLASH AVAILABLE
TELMOS	TML1073	7	±3.2V	40	6	+5V	16	+1 LSB MAX	20-PIN DIP	\$39.90 (100)	SPEED/POWER PROGRAMMABLE (EG.3MHz AT 50 mW)
TRW	TDC1029	6	0 TO -1V	100	60	-5.2V	1.6	+1/2 LSB TYP	24-PIN DOUBLE DIP	\$78 (100)	EUROCARD EVALUATION BOARD AVAILABLE (TDC-1029E1C)
TRW	TDC1027	7	0 TO -1V	20	8	+5V -5.2V	1.6	+1/2 LSB TYP	24-PIN DOUBLE DIP	\$78 (100)	TTL COMPATIBLE
TRW	TDC1007	8	0 TO -2V	30	7	+5V -6V	2	+ 1/2 LSB TYP	64-PIN TRIPLE DIP	\$485 (100)	EVALUATION BOARD AVAILABLE (TDC 1007PCB)
TRW	TDC1025	8	0 TO -2V	60	25	-5.2V	2	+ 1/2 LSB TYP	LEADED OR LEADLESS CHIP CARRIER	\$485 (100)	EUROCARD EVALUATION BOARD AVAILABLE (TDC1025E1C)
TRW	TDC1019	9	0 TO -2V	20	7	-5.2	2.5	+ 1/2 LSB TYP	64-PIN	\$485 (100)	EUROCARD EVALUATION BOARD AVAILABLE (TDC1019EC)

TABLE 5
HIGH SPEED DIGITAL TO ANALOG CONVERTER COMPARISON

SUPPLIER	MODEL NO.	RESOLUTION (bits)	INPUT RANGE (v)	MAX. INPUT FREQUENCY (MHz)	SUPPLIES (V)	POWER (W)	LINEARITY	PACKAGE	PRICE (\$)	REMARKS
SONY	CX20201	10	-0.9 -1.7	100	-5	0.87	+ 1 LSB	28 PIN DIP	80	ECL
TRW	TDC10/8	8	-0.9 -1.7	125	-5.2	0.94	+ 1/2 LSB	24 PIN DIP	50	ECL COMPATIBLE
ANALOG DEVICES	AD.9700	8	-0.9 -1.7	125	-5	0.73	+ 1/2 LSB	22 PIN DIP	34	
HONEYWELL	HDAC-9700	8	-0.9 -1.7	200	-5	0.73	+ 1/2 LSB	22 PIN DIP	28	PIN COMPATIBLE WITH AD9700
INTECH	VDAC-0805	8	-0.9 -1.7	100	-5	1.25	+ 1/2 LSB	24 PIN HYBRID	61	ECL

TABLE 6
DIGITAL SIGNAL PROCESSING CHIPS

SUPPLIER	MODEL NO.	NO. OF CELLS	DATA SIZE (bits)	COEFF. SIZE (bits)	MAX. NO. OF TAPS	MAX. RATE (MHz)	SUPPLY (V)	POWER (W)	PACKAGE	REMARKS
ZORAN	ZR33881	8	8	8	1032	20	5	1	68 PIN LCC	CMOS, PRO- GRAMMABLE FILTER, CONVOLVER CORRELATOR
ZORAN	ZR33481	4	8	8	1032	20	5	0.5	68 PIN LCC	
TRW	TDC1028	4	4	4	>36	10	5	2.5	48 PIN DIP	TTL

TABLE 7
SAW FILTER PERFORMANCE CAPABILITIES

	PRESENT	PROJECTED
Center Frequency (fo)	10 MHz to 4.4 GHz	6 GHz
Bandwidth	2 MHz to .7 fo	500 KHz to .8 fo
Insertion Loss	2 db	1 db
Sidelobe Rejection	60 db	70 db
Ultimate Rejection	90 db	100 db
Deviation from Linear Phase	± 1°	± .5°
Amplitude Ripple	.01 db	.01 db
Temperature Coefficient:		
ST Quartz	0 PPM/°C	---
LINBO3	91 PPM/°C	---

Table 8
A/D Traffic Estimates (Year 2008)
(Half Voice Circuits)

	Low	Medium	High
LAM/C	25,285	60,240	139,000
U.S.	225,700	538,000	690,500

Table 9
A/D Affected Earth Station Estimates

	Low	Medium	High
LAM/C	22	27	32
U.S.	0	500	1183

TABLE 10
SIGNAL PROCESSING FUNCTIONS THAT CAN BE EMBODIED IN A SINGLE CHIP:
CURRENT STATE OF THE ART

CHIP FUNCTION	OUTLINE SPECIFICATION							REMARKS
	SAMPLE RATE (MHz)	WORD LENGTHS(bits)			POWER (W)	TECHNOLOGY		
		DATA	Coeffs	OUTPUT				
A TO D CONVERTERS	100			8	1.5	2 μ ECL	WITH ECL OUTPUT	
PARALLEL MULTIPLIER	5	16x16		32	0.1	3.5 μ CMOS/SOS		
	40	8 x 8		16				
COMPLEX mult/add FFT BUTTERFLY	40	12x12		24	1.5	3 μ ECL 3 μ ECL		
	10					2 μ CMOS/SOS		
FIR FILTER	20	8		25	1.0	2 μ CMOS		
2-D CONVOLVER	15	10		8	1	CMOS/SOS	3X3 CASCADABLE	
D/A	100	10			1.0	2 μ ECL		
	125	8			1.0			

TABLE 11

**SIGNAL PROCESSING FUNCTIONS THAT CAN BE EMBODIED IN A SINGLE CHIP:
PROJECTED 1993 STATE OF THE ART**

CHIP FUNCTION	OUTLINE SPECIFICATION							REMARKS
	SAMPLE RATE (MHz)	WORD LENGTHS(bits)			POWER (W)	TECHNOLOGY		
		DATA	Coeffs	OUTPUT				
A to D CONVERTERS	4000			4	1.5	1 μ ECL	WITH ECL OUTPUT	
	1000			8	1.5			
PARALLEL MULTIPLIER	100	16x16		32	0.1	1 μ CMOS/SOS 1 μ ECL		
COMPLEX mult/add FFT BUTTERFLY	100					1 μ CMOS/SOS		
FIR FILTER	50	16	16	32	1.0	1 μ CMOS		
2-D CONVOLVER	50	10	8		1	1 μ CMOS/SOS	7 x 7 CASCADABLE	
D/A	1000	10			1.0	1 μ ECL		
	2000	8			1.0			

TABLE 12
QUALITATIVE COMPARISON OF A/D CONCEPTS

FUNCTION	COMPLEXITY OF IMPLEMENTATION		
	ANALOG FILTERING CURRENT	1993	DIGITAL FILTERING CURRENT
Timing & Control Requirements	Low	Low	High
Fixed Filter Bank	Low	Low	Moderate
Programmable Filter Bank	High	Moderate	Moderate
FM Demodulator	Low	Low	Moderate
A/D	Low	Low	Moderate

TABLE 13
 QUANTITATIVE COMPARISON OF A/D CONCEPTS
 ANALOG FILTERING

FUNCTION*	POWER (W)	CURRENT		COST† (\$)	POWER (W)	1993		COST† (\$)
		WT (LB)	SIZE (IN)			WT (LB)	SIZE (IN)	
Analog Filter Bank	20	4	5x5x4	10,000	5	2	4x4x3	2,000
Demod Bank	5	3	4x4x4	5,000	1	1	4x4x3	1,000
A/D	5	3	6x6x3	1,000	1	1	3x3x1	100
Total:	30	10	--	16,000	7	4	--	3,100

† Costing based on off-the-shelf component availability (no NRE)

* Based on a single 36 MHz channel

TABLE 14
QUANTITATIVE COMPARISON OF A/D CONCEPTS
DIGITAL FILTERING

FUNCTION*	POWER (W)	CURRENT			POWER (W)	COST† (\$)	SIZE (IN)	1993		COST† (\$)
		WT (LB)	WT (LB)	WT (LB)				WT (LB)	SIZE (IN)	
Digital Filter Bank	150	40	24x24x12	50,000	20	2	5x5x4			5,000
Demodulator	10	6	8x4x4	20,000	1	1	4x4x2			2,000
A/D	3	2	6x4x3	1,000	1	1	3x3x1			100
Total	163	48	--	71,000	22	4	--			7,100

† Costing based on off-the-shelf component availability (no NRE)

* Based on a single 36 MHz channel

Table 15
INTERNATIONAL COST COMPARISON
(36 MHz)

EARTH STATION	# UNITS			NRE				TOTAL				
	A/D	A/D	NO	DEV.	SPACE	QUAL	RECUR	I&T	OTHER	A/D	NO	A/D
TERRESTRIAL IF	-	4315	0	-	167.4					-	167.4	
DIGITAL MUX	-	3400	0	-	160.1					-	160.1	
QPSK MODEM	-	785	0	-	16.2					-	16.2	
SATELLITE	93	99	0	0	1		.08			1.08	1.08	
LO, BPF	93	99	20	35	2		.16			2.75	2.72	
ANALOG FILTER	93	-	40	35	.1		-			.91	-	
A/D	93	-	40	35	.1		-			.91	-	
D/A	-	99	0	0	2		.16			-	2.16	
QPSK MODEM	93	99	10	35	2		.16			2.64	2.61	
U/C, ANALOG MUX	93*	-	1230	15	4.4		.35			17.98	-	
SWITCH 1	-	99*	862	15	1.0		.08			-	9.79	
SWITCH 2	-	-	-	-	-		-	6.18+		-	6.18	
BW EFF. PENALTY	A	B	C	D	E	F	G					
							E/S				343.7	
							SAT			26.27	24.54	

NOTES

ALL COSTS \$(000) 1986

* ONE SWITCH SHARED BETWEEN ALL TRANSPONDERS

+ COST OF 6 ADDITIONAL TRANSPONDER /99

$$\text{TOTAL (A/D)} = \frac{C + D + E + F + G}{A}$$

Table 16
INTERNATIONAL POWER AND MASS
COMPARISON

SATELLITE	# UNITS			A/D			NO A/D		
	A/D	A/D	NO	WT	PWR	WT	PWR	WT	PWR
LO, BPF	93	99	1	93	2	93	186	99	198
ANALOG FILTER	93	99	2	186	5	186	465	198	495
A/D	93	-	1	93	1	93	93	-	-
D/A	93	-	1	93	1	93	93	-	-
QPSKMODEM	-	99	1	-	1	-	-	99	99
U/C, ANALOG, MUX	93	99	2	186	3	186	279	198	297
SWITCH 1	1	1	49.7	49.7	80	-	80	-	-
SWITCH 2	-	6	10.8	-	17.5	-	-	10.8	17.5
B/W EFF. PENALTY	-	-	10.7	-	20.1	-	-	64.2	120.6
Totals				700.7		1196		669	1227.1

NOTES:

WEIGHT IN LBS, POWER IN W

Table 17
INTERNATIONAL SUMMARY OF COSTS

	A/D	NO A/D
EARTH STATION PAYLOAD (NRE + REC)	-	34026
POWER	2443	2429
LAUNCH (P/L + POWER + FUEL)	1196	1227
	2103	2029
TOTAL	\$5.7M	\$39.7M

NOTE*
COSTS IN \$(000), EXCEPT TOTALS.

Table 18
 U.S. DOMESTIC COST COMPARISON
 (36 MHz)

SATELLITE	# UNITS		NRE		RECUR	I&T	OTHER	TOTAL	
	A/D	NO A/D	DEVELOP	SPACE QUAL				A/D	NO A/D
LO, BPF	126		0	0	1	.08		1.08	
ANALOG FILTER	126		20	35	2	.16		2.60	
A/D	126		40	35	.1	-		.70	
D/A	126		40	35	.1	-		.70	
U/C, ANALOG MUX	126		10	35	2	.16		2.52	
SWITCH	126*		862	15	4.4	.35		11.71	
TRANSPONDER		189		0	172.1	incl	13.7+		172.1
FILL PENALTY									13.7
COLUMN →	A	B	C	D	E	F	G	TOTALS	185.8
									19.31

NOTES:

ALL COSTS \$ (000) 1986

UNITS BASED ON SEVEN SCENARIO V PAYLOADS

* SEVEN SWITCHES SHARED BETWEEN ALL TRANSPONDERS

+ COST OF 15 ADDITIONAL TRANSPONDER / 189

$$\text{TOTAL (A/D)} = \frac{C + D + E + F + G}{A}$$

Table 19
 U.S. DOMESTIC POWER AND MASS
 COMPARISON

SATELLITE	# UNITS		WT	POWER	AD		TOTALS	
	A/D	NO A/D			WT	POWER	WT	POWER
LO, BPF	126		1	2	126	252	-	-
ANALOG FILTER	126		2	5	252	630	-	-
A/D	126		1	1	126	126	-	-
D/A	126		1	1	126	126	-	-
U/C, ANALOG MUX	126		2	3	252	378	-	-
SWITCH	7		10.8	17.5	75.6	122.5	-	-
TRANSPONDER		189	7.54	9.57	-	-	1425.1	1808.7
FILL PENALTY		15	7.54	9.57	-	-	113.1	143.6
			Totals (7 SAT)		957.6	1634.5	1538.2	1952.3
			Totals (1 SAT)		136.8	233.5	219.7	278.9

NOTES;

WEIGHT IN LBS, POWER IN W

UNITS BASED ON SEVEN SCENARIO V PAYLOADS

Table 20
U.S. DOMESTIC SUMMARY OF COSTS

	A/D	NO A/D
PAYLOAD (NRE + REC)	2433.1	35116.2
POWER	1634.5	1952.3
LAUNCH (P/L + POWER + FUEL)	4067	6291
TOTAL	\$8.13M	\$43.4M

NOTES

COSTS IN \$ (000), EXCEPT TOTALS

LAUNCH COSTS CALCULATED FOR SINGLE SATELLITE AND MULTIPLIED BY SEVEN

TABLE 21
INTELSAT-V COST COMPARISON
(36 MHz)

SATELLITE	# UNITS		NRE			RECUR	I&T	OTHER	TOTAL	
	A/D	NO A/D	DEVELOP	SPACE QUAL	A/D				NO A/D	
LO, BPF	96		0	0	1	.08			1.08	
ANALOG FILTER	96		20	35	2	.16			2.73	
A/D	96		40	35	.1	-			.88	
D/A	96		40	35	.1	-			.88	
U/C, ANALOG MUX	96		10	35	2	.16			2.63	
SWITCH	96*		862	15	4.4	.35			13.89	
TRANSPONDER		189	0	0	172.1	incl		52.5+		172.1
FILL PENALTY										52.5
COLUMN →	A	B	C	D	E	F	G	TOTALS	22.09	52.5

NOTES:

ALL COSTS \$ (000) 1986

UNITS BASED ON TWELVE INTELSAT-V'S

* TWELVE SWITCHES SHARED BETWEEN ALL TRANSPONDERS

+ COST OF 36 ADDITIONAL TRANSPONDER / 96

TOTAL (A/D) = $\frac{C+D+E+F+G}{A}$

TABLE 22

INTELSAT-V POWER AND MASS COMPARISON

SATELLITE	# UNITS		AD			NO AD								
	A/D	NO A/D	WT	POWER	WT	POWER	WT	POWER						
LO, BPF	96		1	2	96	192	-	-						
ANALOG FILTER	96		2	5	192	480	-	-						
A/D	96		1	1	96	96	-	-						
D/A	96		1	1	96	96	-	-						
U/C, ANALOG MUX	96		2	3	192	228	-	-						
SWITCH	12		4.8	7.8	57.6	93.3	-	-						
TRANSPONDER		189	7.54	9.57	-	-	1425.1	1808.7						
FILL PENALTY		36	13.43	24.6	-	-	483.5	885.6						
Totals (7 SAT)			729.6			1245.3			483.5			885.6		
Totals (1 SAT)			60.8			103.8			40.3			73.8		

NOTES;

WEIGHT IN LBS, POWER IN W

UNITS BASED ON TWELVE INTELSAT-V'S

TABLE 23
 INTELSAT-V
 SUMMARY OF COSTS

	A/D	NO A/D
PAYLOAD (NRE + REC)	2120.6	5040.0
POWER	1245.3	885.6
LAUNCH (P/L + POWER + FUEL)	21597.0	14653.0
TOTAL	\$24.9M	\$20.6M

NOTES

COSTS IN \$ (000), EXCEPT TOTALS

LAUNCH COSTS CALCULATED FOR SINGLE SATELLITE AND MULTIPLIED BY TWELVE

TABLE 24
INTELSAT-VI COST COMPARISON
(36 MHz)

SATELLITE	# UNITS		NRE			RECUR	I&T	OTHER	TOTAL	
	A/D	NO A/D	DEVELOP	SPACE	QUAL				A/D	NO A/D
LO, BPF	60		0	0	0	1	.08		1.08	
ANALOG FILTER	60		20	35	35	2	.16		3.07	
A/D	60		40	35	35	.1	-		1.35	
D/A	60		40	35	35	.1	-		1.35	
U/C, ANALOG MUX	60		10	35	35	2	.16		2.91	
SWITCH	60*		862	15	15	4.4	.35		19.37	
TRANSPONDER		189	0	0	0	172.1	incl	58.3+		172.1
FILL PENALTY										58.3
	A	B	C	D	E	F	G	TOTALS	29.13	58.3

NOTES:

ALL COSTS \$ (000) 1986

UNITS BASED ON FIVE INTELSAT-VIS

* FIVE SWITCHES SHARED BETWEEN ALL TRANSPONDERS

+ COST OF 25 ADDITIONAL TRANSPONDER / 60

TOTAL (A/D) = $\frac{C+D+E+F+G}{A}$

TABLE 25
INTELSAT-VI POWER AND MASS COMPARISON

SATELLITE	# UNITS		WT	POWER	AD		TOTALS	
	A/D	NO A/D			WT	POWER	WT	POWER
LO, BPF	60		1	2	60	120	-	-
ANALOG FILTER	60		2	5	120	300	-	-
A/D	60		1	1	60	60	-	-
D/A	60		1	1	60	60	-	-
U/C, ANALOG MUX	60		2	3	120	180	-	-
SWITCH	5		7.2	11.7	36.0	58.5	-	-
TRANSPONDER		189	7.54	9.57	-	-	1425.1	1808.7
FILL PENALTY		25	11.61	24.1	-	-	290.3	602.5
			Totals (7 SAT)		456	778.5	290.3	602.5
			Totals (1 SAT)		91.2	155.7	58.1	120.5

NOTES;

WEIGHT IN LBS, POWER IN W

UNITS BASED ON FIVE INTELSAT-VI'S

TABLE 26
 INTELSAT-VI
 SUMMARY OF COSTS

	A/D	NO A/D
PAYLOAD (NRE + REC)	1747.8	3498.0
POWER	778.5	602.5
LAUNCH (P/L + POWER + FUEL)	6326.0	4272.0
TOTAL	\$8.9M	\$8.36M

NOTES

COSTS IN \$ (000), EXCEPT TOTALS

LAUNCH COSTS CALCULATED FOR SINGLE
 SATELLITE AND MULTIPLIED BY FIVE

FIGURE 1 ACCESS SIZE RESULTS

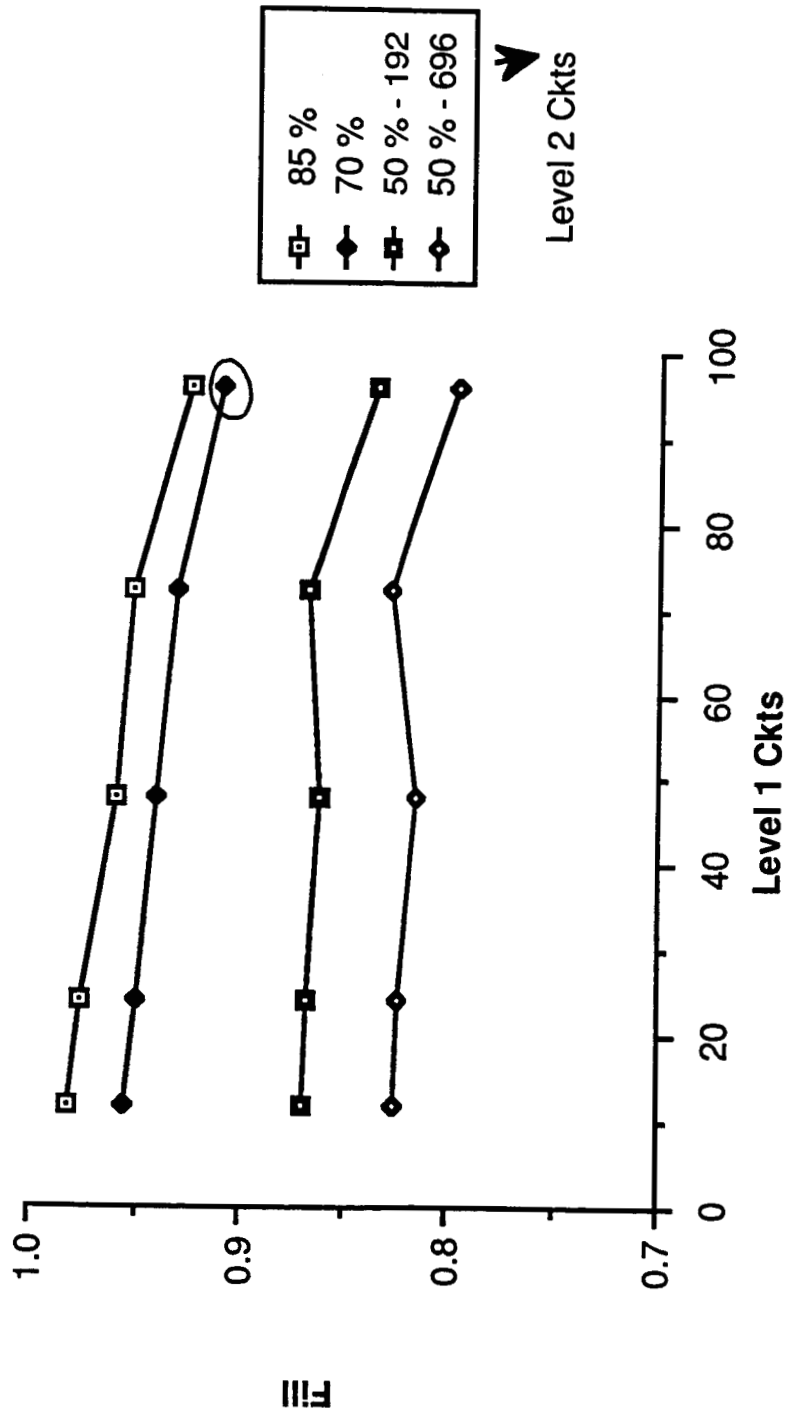

Level 2 Ckts

Figure 1A ACCESS SIZE RESULTS (CONT'D)

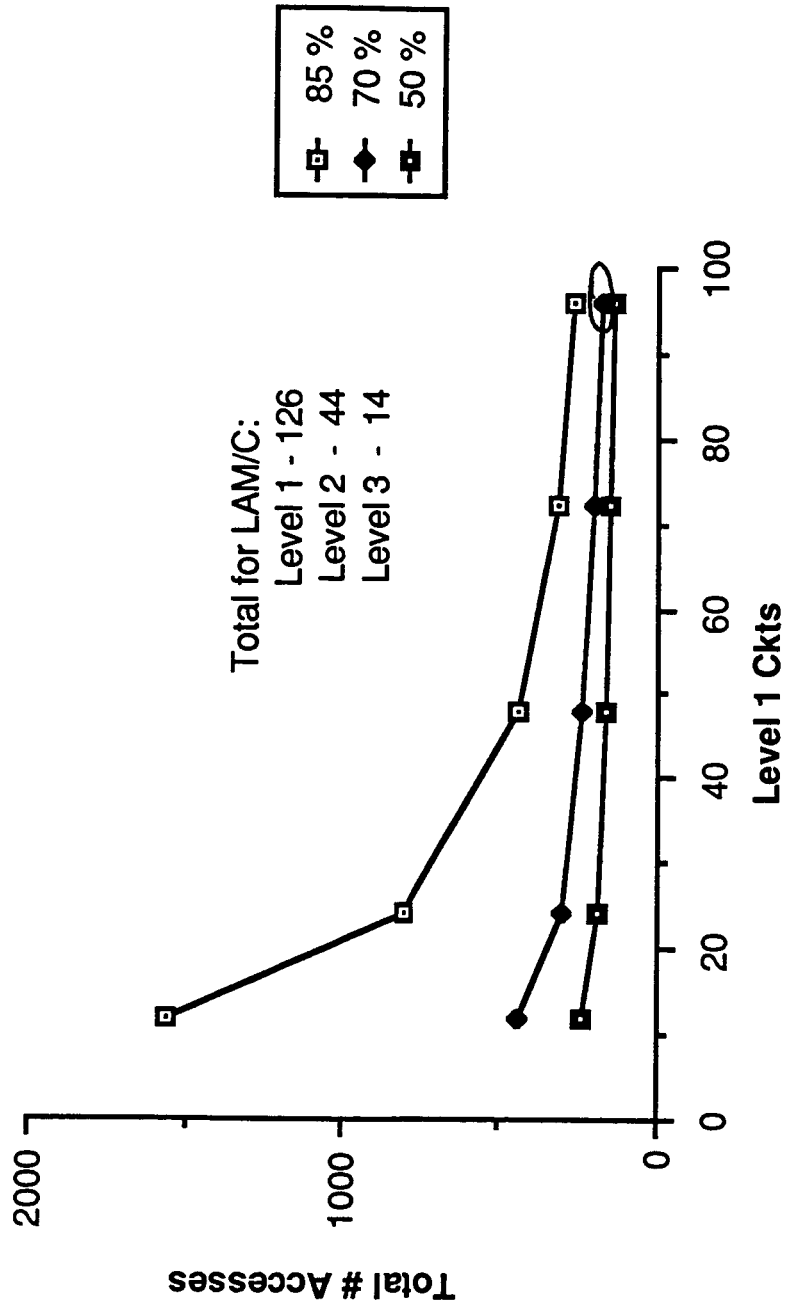

Figure 2
SWITCHED FILTER BANK (36 MHz)

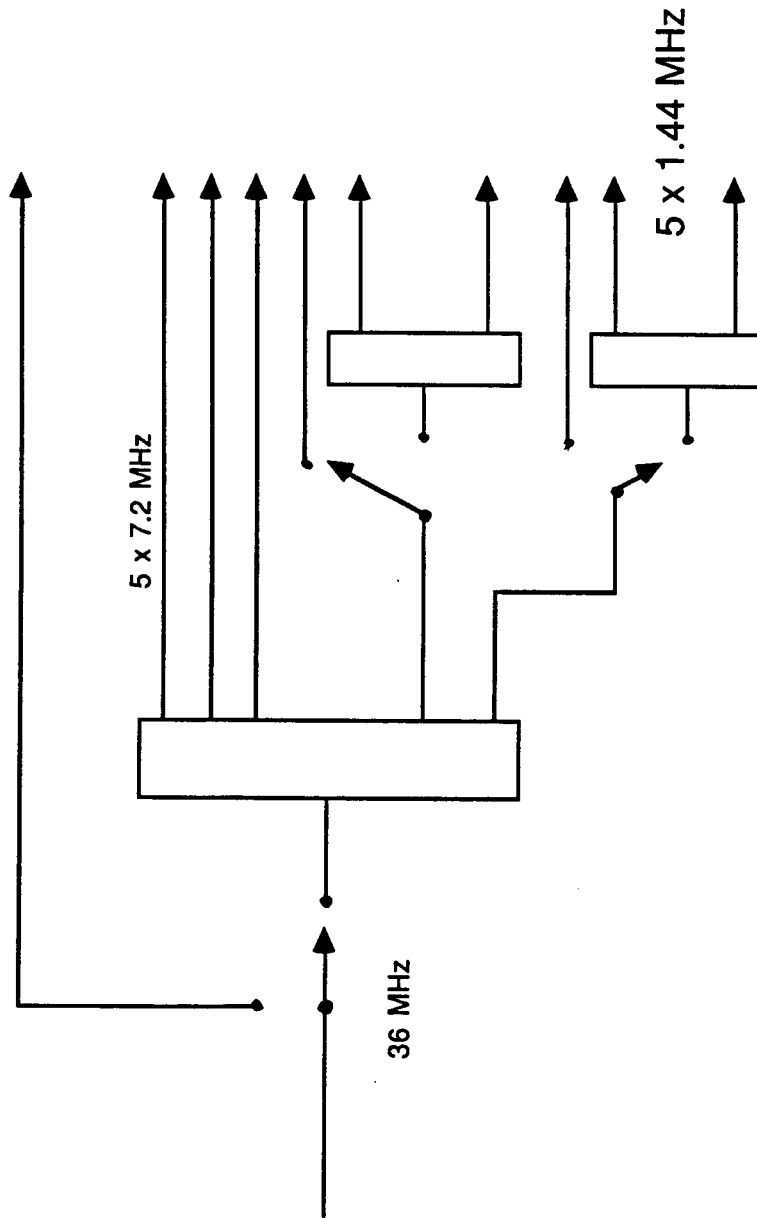

Figure 3
 BLOCK DIAGRAM OF CONCEPT 1
 ANALOG FILTERING APPROACH

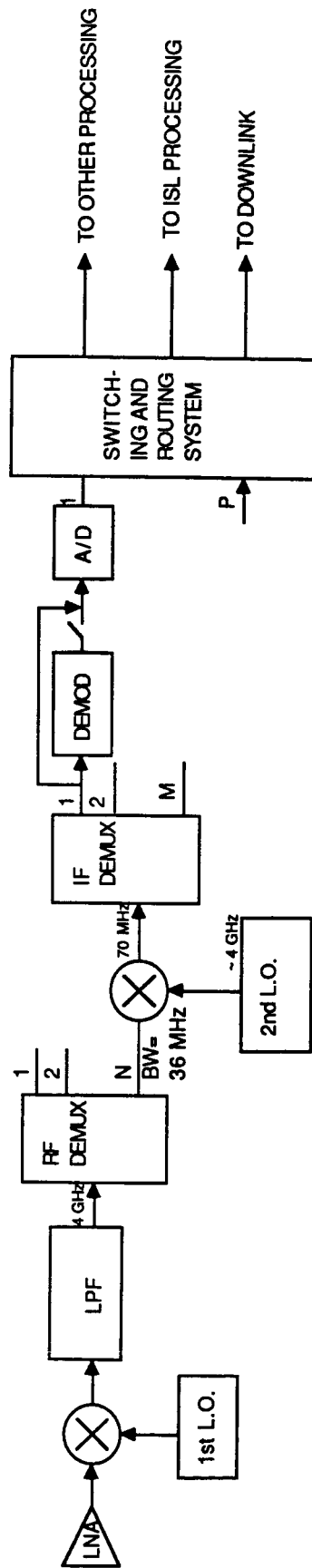
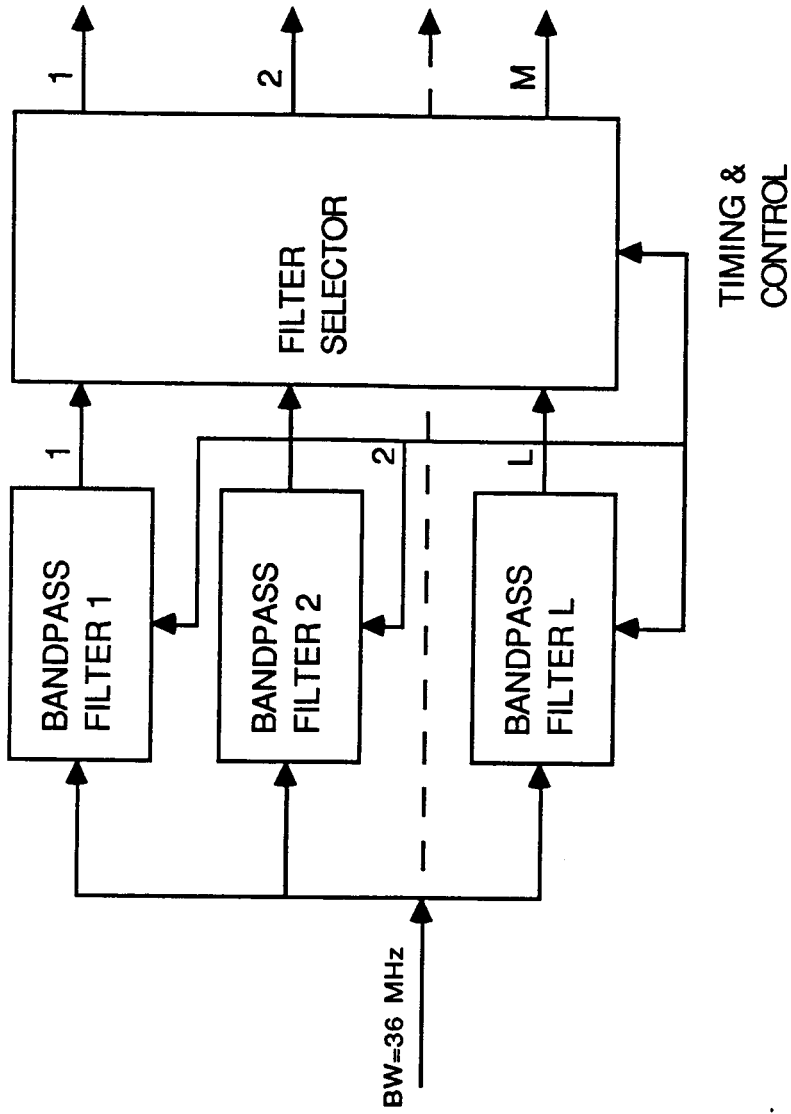

Figure 4
BLOCK DIAGRAM OF I.F. DEMUX



CONCEPT 1: CONTD

BANDPASS FILTER BANK IS EITHER:
FIXED PASSBAND SWITCHABLE FILTER BANK
OR: TUNABLE PASSBAND PROGRAMMABLE FILTER BANK

Figure 5
ILLUSTRATION OF IMPLEMENTATION OF IF DEMUX
USING FIXED PASSBAND SWITCHABLE SAW FILTERS

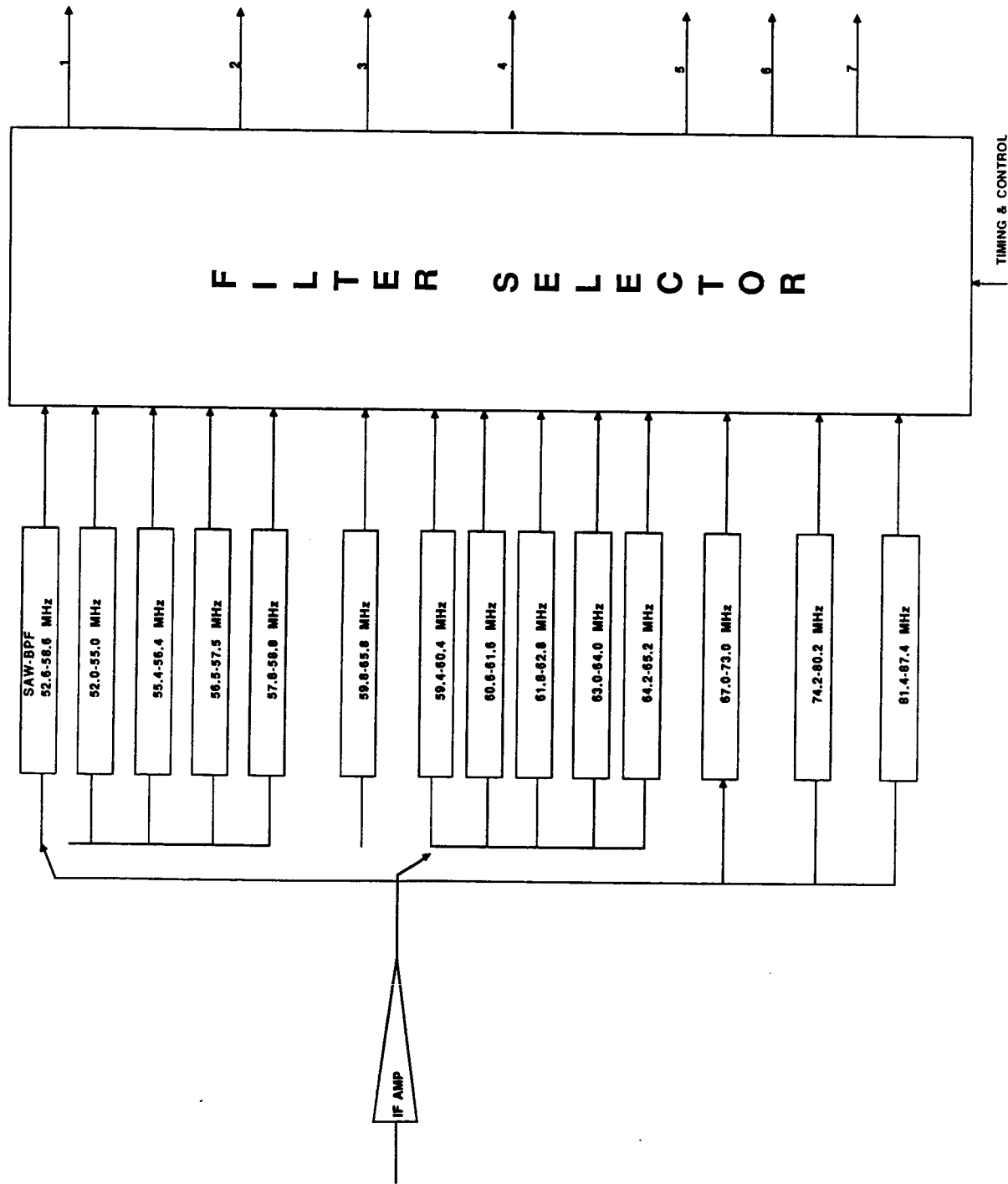

FIGURE 6
 BLOCK DIAGRAM OF CONCEPT 2:
 A/D PRIOR TO DIGITAL FILTERING

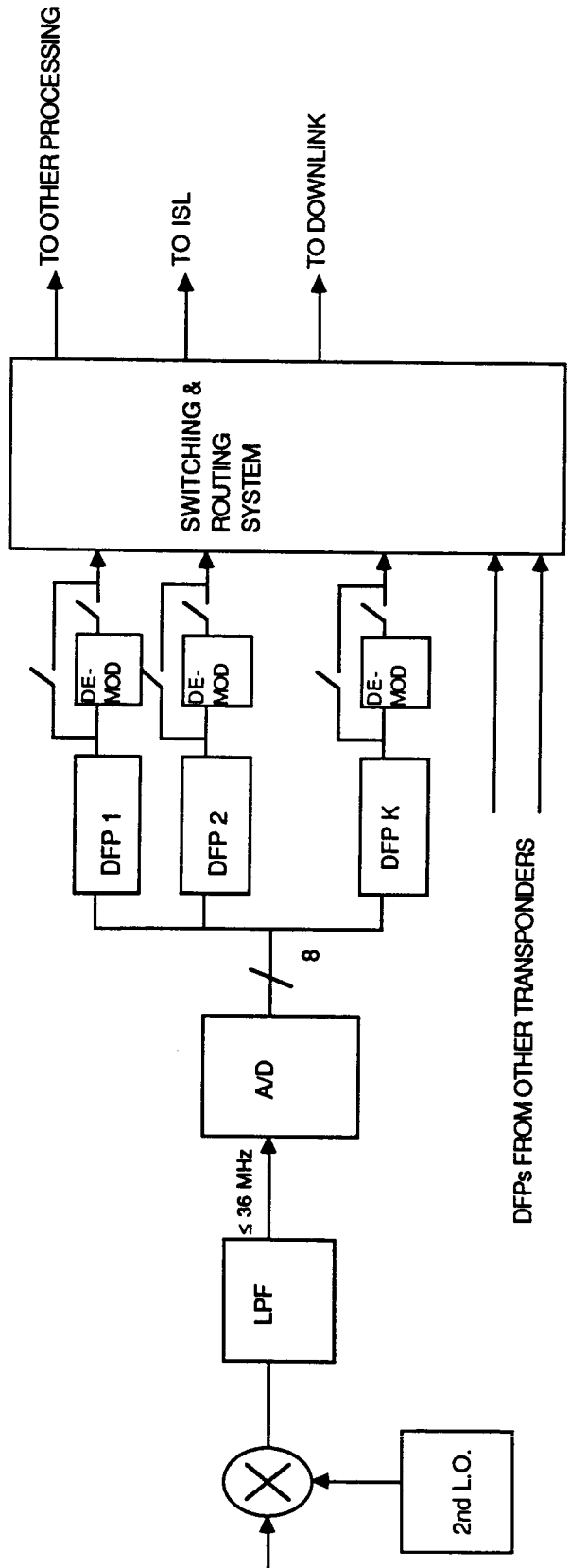

FIGURE 7
 ILLUSTRATION OF IMPLEMENTATION OF
 DIGITAL FILTER PROCESSOR (DFP) BANK

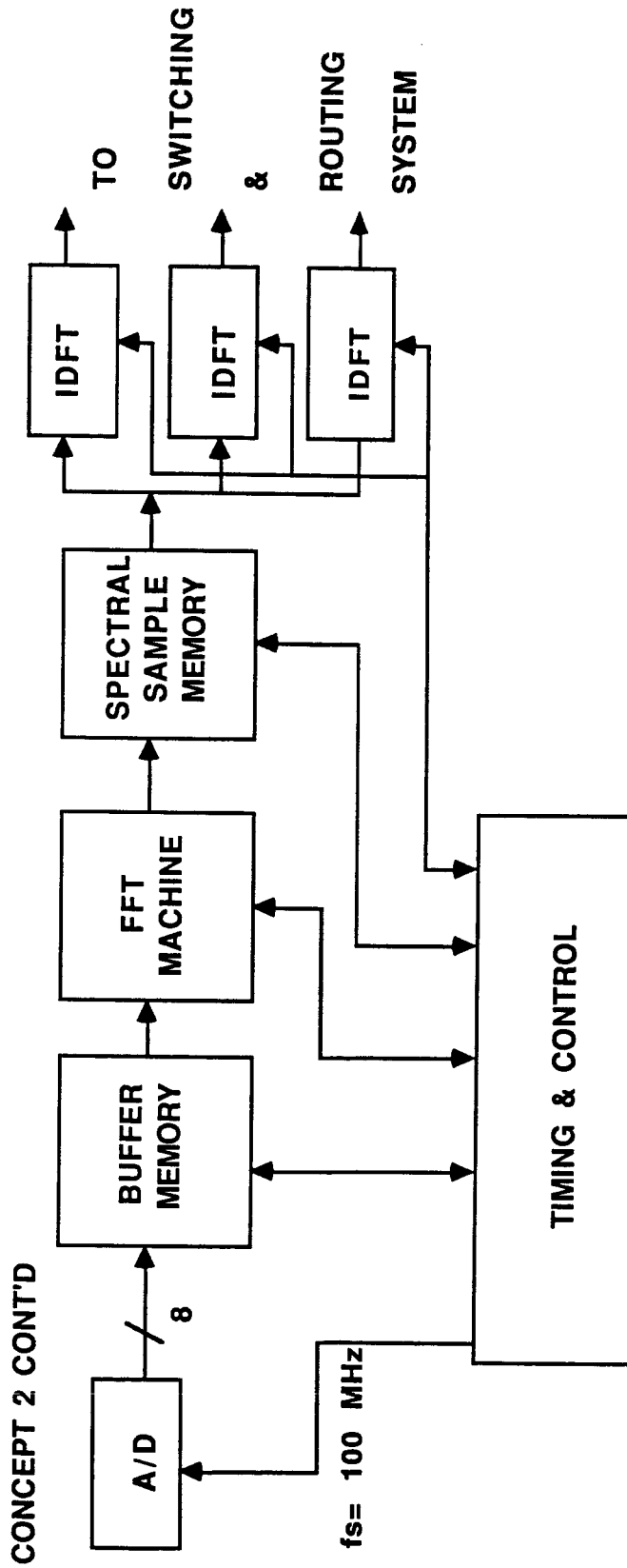

Figure 8
ILLUSTRATION OF IMPLEMENTATION

SWITCHING AND ROUTING SYSTEM
FUNCTIONAL REQUIREMENTS:
- Information Collection
- Frame Formation
- Routing/Flow Control

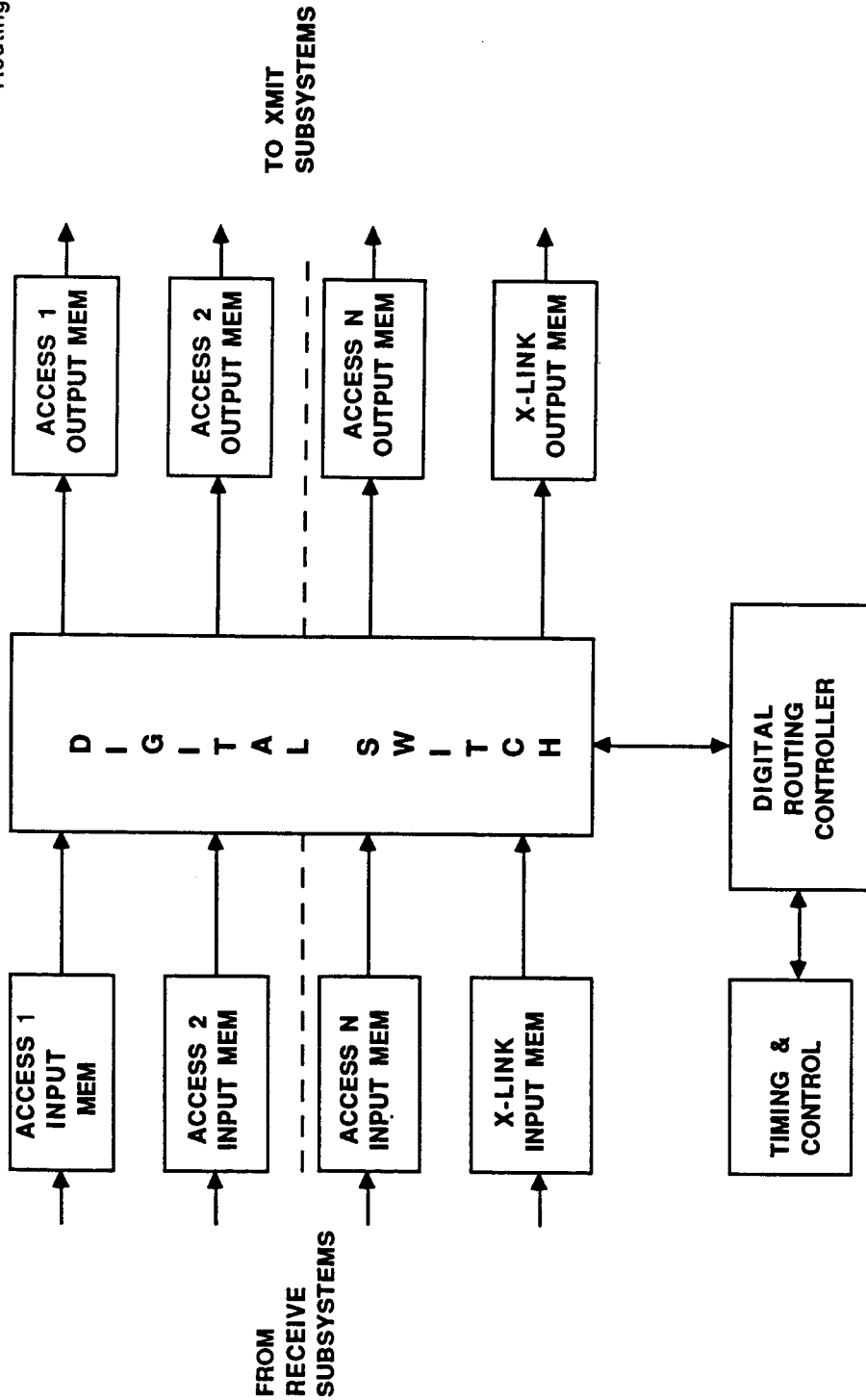

Figure 9
 CONCEPT FOR DIGITAL TO ANALOG CONVERSION

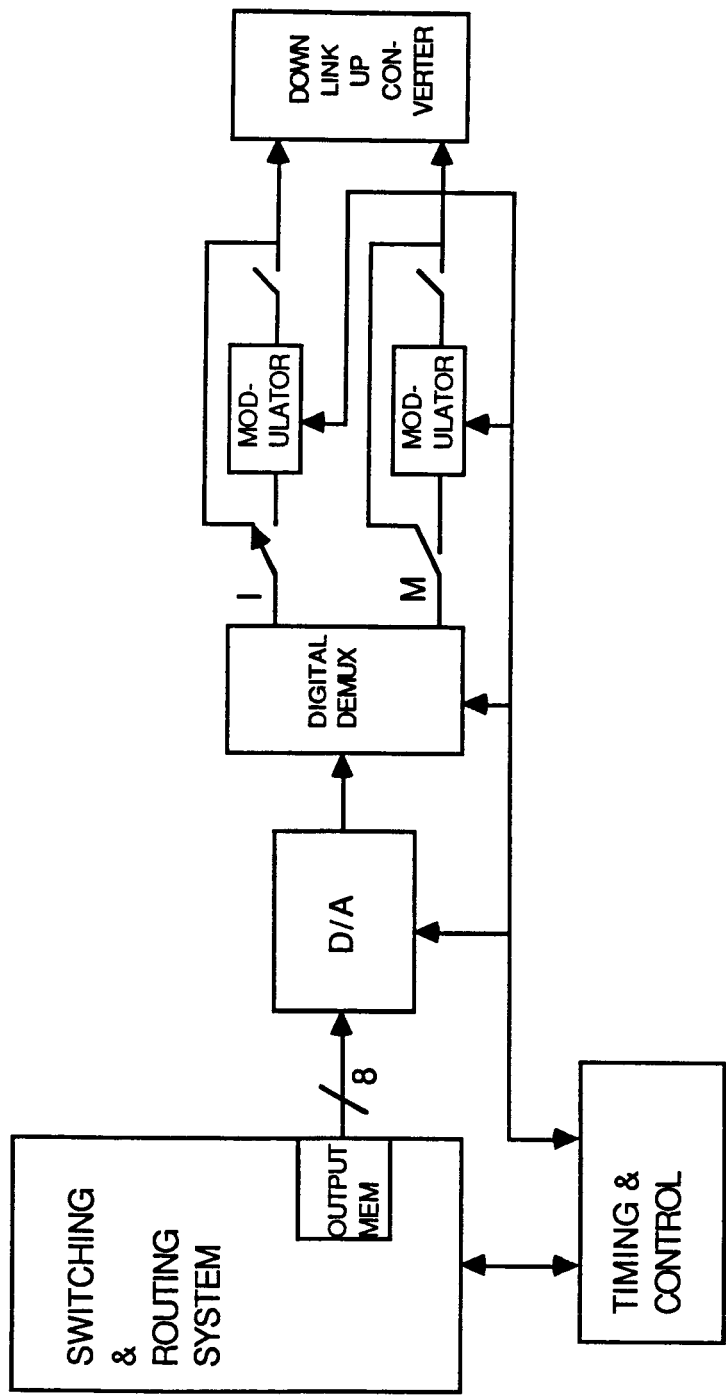

Figure 10 INTERNATIONAL OPTIONS

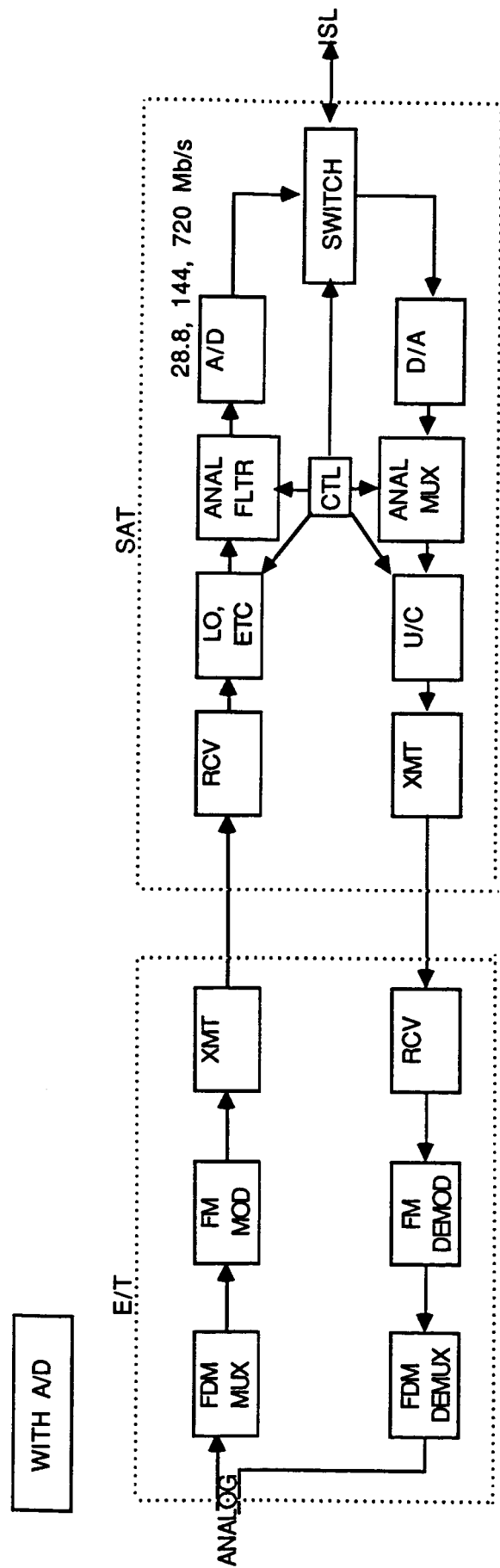
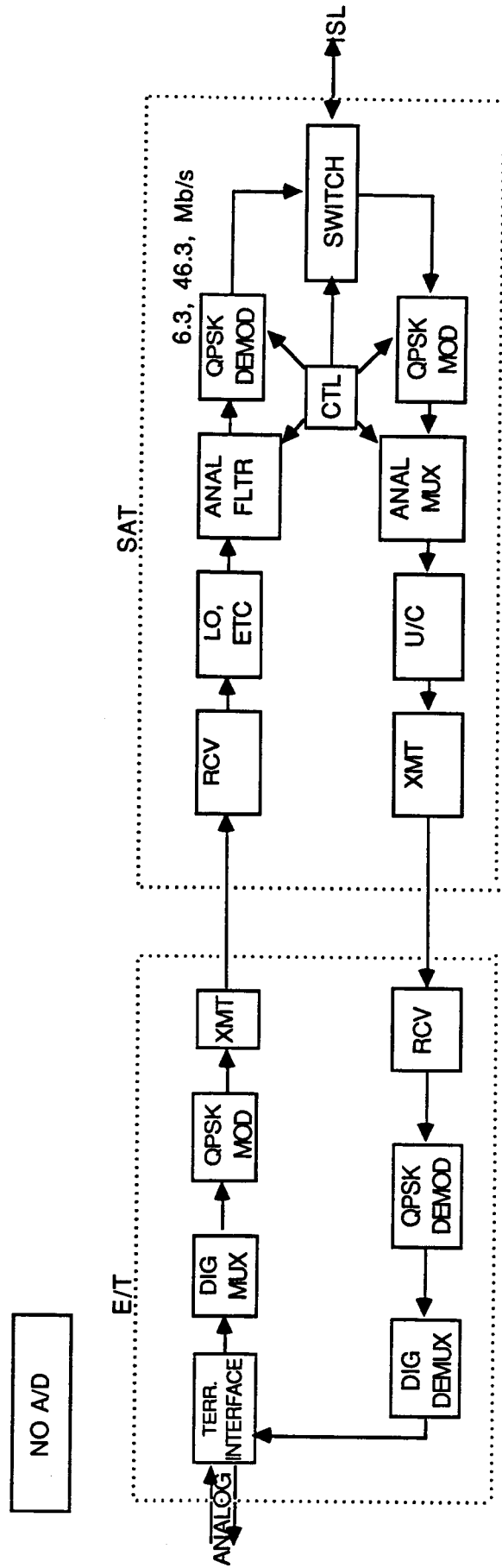

Figure 11 INTERNATIONAL OPTIONS



8131/84
2/27/01

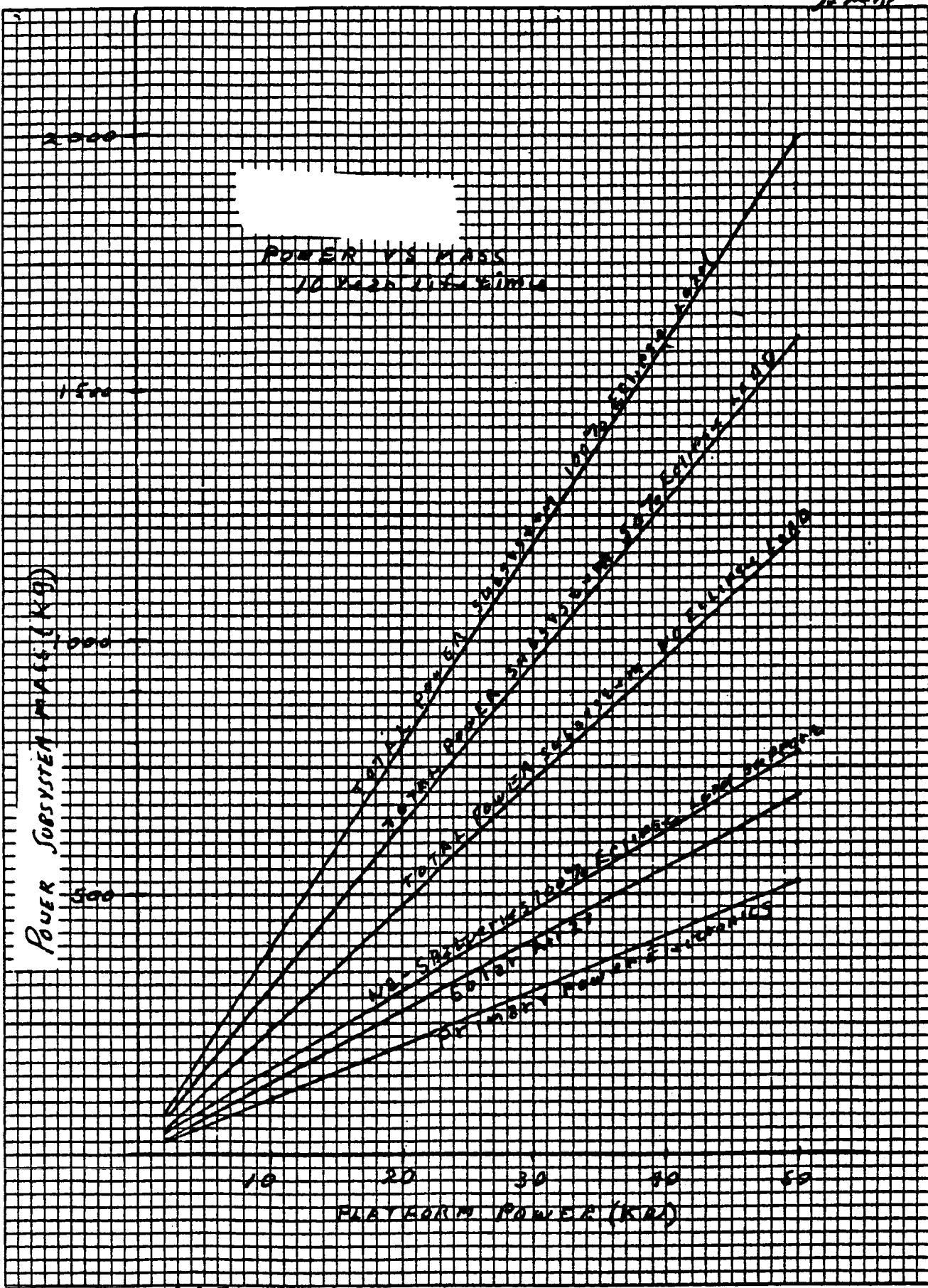

FIGURE 12 PLATFORM POWER SUBSYSTEM MASS AS A FUNCTION OF

PLATFORM POWER - 10 YEAR LIFETIME

ORIGINAL PAGE IS
OF POOR QUALITY

FIGURE 13 CROSSOVER ANALYSIS (INT'L)

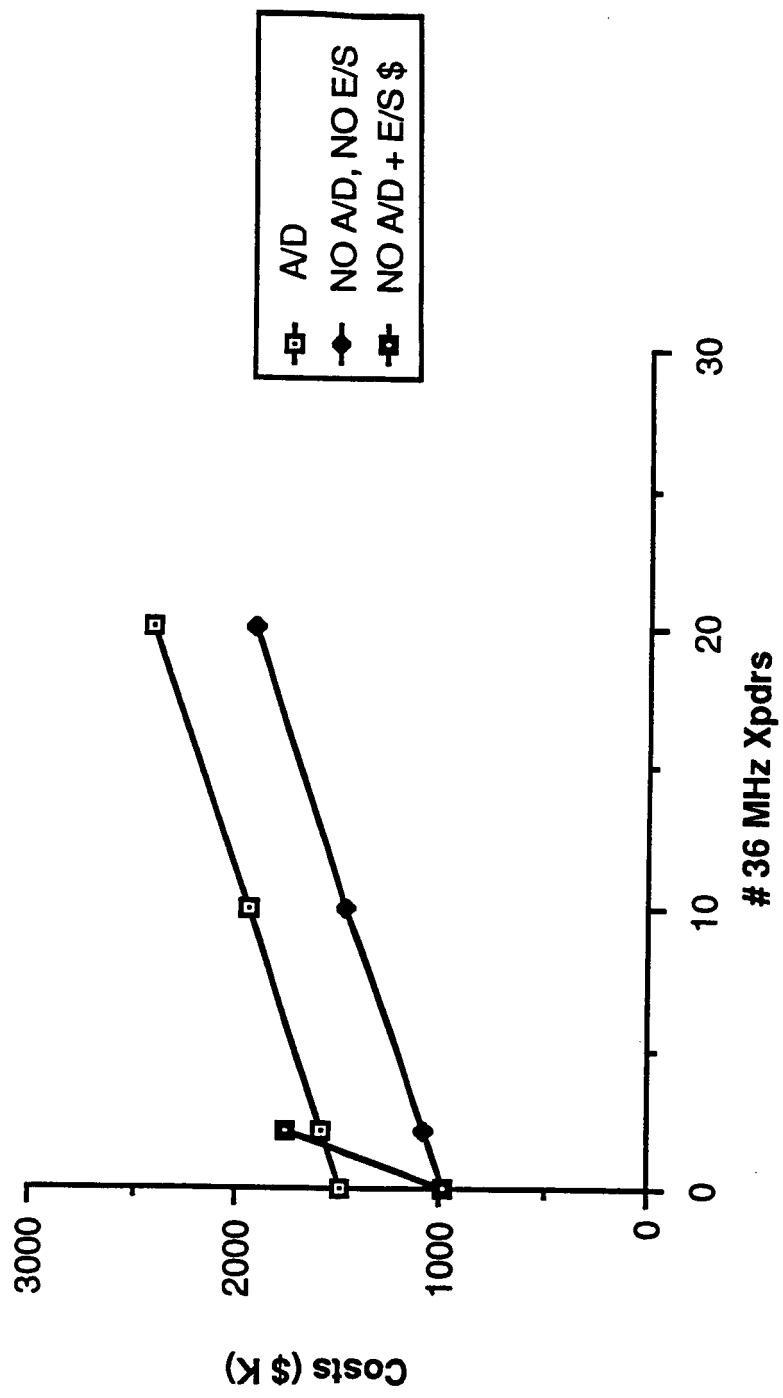
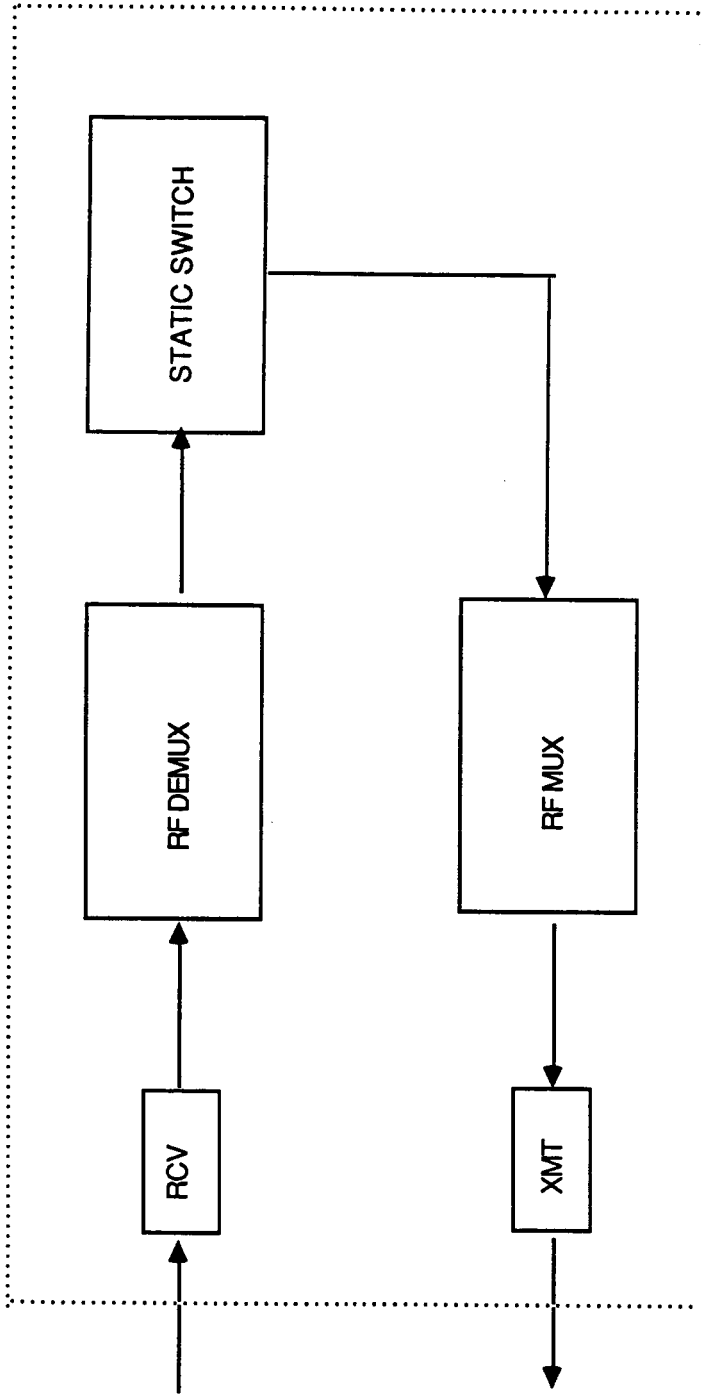

Figure 14
U.S. DOMESTIC OPTIONS
(SCENARIO V OF CPPD STUDY)



NOTES

EACH C & Ku BEAM OF SCENARIO V HAD ONE TRANSPONDER SPLIT INTO 2-18 MHz AND ONE TRANSPONDER INTO 3-12 MHz CHANNELS