

N87-20936

THE TOPOLOGICAL DESCRIPTION OF CORONAL MAGNETIC FIELDS

Mitchell A. Berger
High Altitude Observatory
National Center for Atmospheric Research
Boulder, Colorado

INTRODUCTION

Determining the structure and behavior of solar coronal magnetic fields has been a central problem in solar physics. Unfortunately, even modelling the equilibrium states of the field has proven to be difficult in general, because the equations describing magnetic equilibria are nonlinear, and the boundary conditions can be of great complexity. One fruitful approach has involved studying idealized geometries which admit exact analytic solutions, or which can be conveniently modelled numerically (for a review, see Low 1986). Such geometries, because of their relative simplicity, work best when applied to large-scale or global structures. However, closed magnetic regions may contain significant structure on smaller scales, because convective motions in the photosphere can wrap the coronal field lines about each other in a complicated manner. Dissipation of this structure may provide the source of coronal heating in active regions (e.g., Parker 1972, 1983; Sturrock and Uchida 1981; van Ballegooijen 1986). Because of this possible role in coronal heating, it is important to understand the behavior of fields with complex wrapping patterns. Even though such fields may be too complicated to be described exactly, topological considerations provide useful information on the field behavior.

At the photosphere, the field is believed to be strongly localized into discrete flux tubes. As these flux tubes extend into the tenuous corona, they expand to fill available space. The chaotic photospheric motions braid the tubes about each other, and twist up field lines within the tubes. This induces coronal structure on a lengthscale corresponding to the typical distance d between the photospheric *footpoints* of the tubes (say $d \sim 10^3$ km for a plage region). Because of this, coronal fields can be conveniently modelled as a collection of simple tubes braided about each other. The rate at which photospheric motions braid coronal flux tubes has been investigated by Berger (1986b). Of course, field lines emanating from a positive footpoint do not generally form a single tube connecting to a single negative footpoint. First, even if initially the field consists of unbroken flux tubes, reconnection can break the tubes and redistribute their flux. Secondly, at the photosphere, some small amount of flux presumably exists between the localized tubes. (Frazier and Stenflo (1972) estimate $\sim 5\%$ of the flux in active regions may lie outside the tubes.) Third, photospheric tubes have a finite lifetime, and may occasionally disperse and reform.

We suggest, however, that on the intermediate scale d the physics may be qualitatively studied by considering a collection of simple coherent flux tubes. Whether or not coherent flux tubes exist, photospheric motions can still provide topological structure on the scale of 10^3 km, which may be crucial for heating. For example, in the top half of figure 1, large bundles of flux are twisted and braided. At the middle of the figure these bundles lose their identity and new bundles form. Nevertheless, the twisting and braiding in the top half cannot be removed by ideal (nonresistive) motions, because these motions preserve the field topology. At lengthscales of 10^3 km, the ordinary resistive timescale is large ($\sim 10^{12}$ s for $T = 10^6$ K), so rapid reconnection is needed to dissipate such structure (Parker 1972, 1983). After providing a rigorous definition of *field topology*, we discuss how the topology of a finite collection of flux tubes may be classified. Finally, we discuss the relevance of field topology to the question of the existence of smooth magnetostatic equilibria (defined to be equilibria without singular electric current sheets).

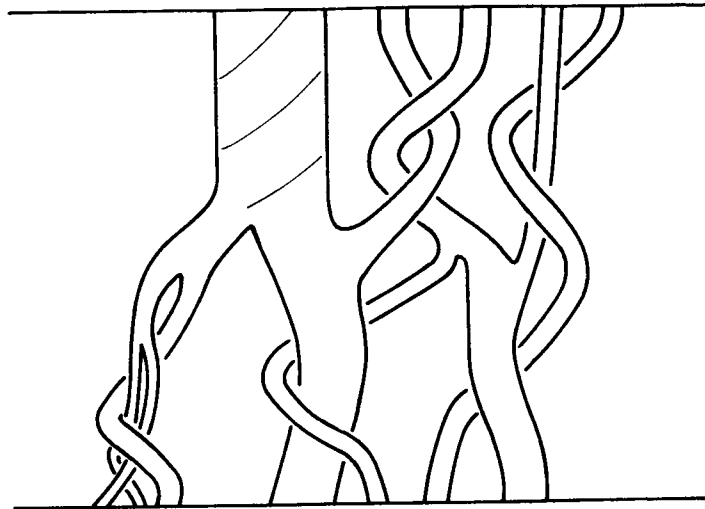

FIGURE 1

DEFINITION OF FIELD TOPOLOGY

Suppose we prepare the coronal field in some arbitrary initial state. Let the resistivity be zero, but include fluid viscosity. If the field is released from its initial state, it will thrash about until eventually relaxing to an equilibrium. Because the photosphere is relatively dense and slow, the footpoints should move little during this process ($\vec{B} \cdot \hat{n}|_{\text{photosphere}}$ is unchanged). This scenario has been employed recently to construct nonlinear force-free equilibria (Yang, Sturrock, and Antiochos 1986).

Because of the zero resistivity, field lines can not pass through each other during the motions. Thus, the initial wrapping pattern of the field lines severely restricts the possible wrapping patterns of the final equilibrium state. Of course, the initial and final wrapping patterns may look quite different, but in some deeper topological sense they must be equivalent. These considerations motivate the following definition: *two coronal field configurations are topologically equivalent if one can be deformed into the other by purely ideal motions vanishing at the photosphere* (Berger, 1986a). The *field topology* of a particular configuration refers to the *equivalence class* of topologically equivalent fields. Alternatively, the field topology may be considered as the set of all ideal MHD invariants of the field. With this definition, the field topology can only change if 1) the footpoints move, or 2) reconnection occurs. For example, the two braiding patterns in figure 2 are topologically equivalent.

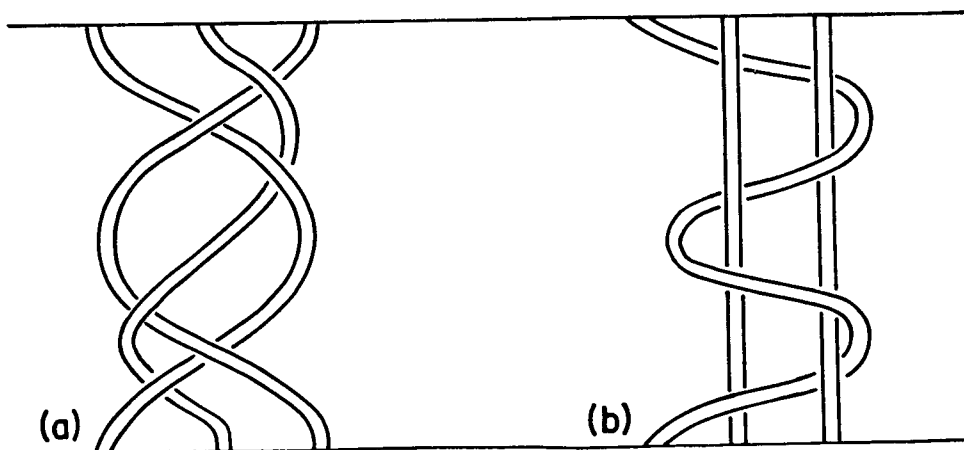

FIGURE 2

THE TOPOLOGY OF BRAIDED FLUX TUBES

First consider a single flux tube. We assume that the mapping of field lines from positive to negative endpoints is continuous. This mapping determines the topology, except for one source of ambiguity: the tube could be rotated by 2π without changing the mapping. Let \mathcal{T} be the net angle through which a field line rotates about the central axis of the tube (divided by 2π). The ambiguity can be removed by specifying \mathcal{T} for a field line on the outer boundary of the tube. The twist of other lines about the axis can be obtained by continuity. Alternatively, one could specify the *magnetic helicity* H (Moffatt 1969; Berger and Field 1984), which measures the tube's mean twist. For a uniformly twisted tube of twist \mathcal{T} and flux Φ , $H = \mathcal{T}\Phi^2$. In general, H/Φ^2 changes by ± 1 if the tube is rotated by 2π .

For two tubes, we suppose that the mapping of positive to negative footpoints is piecewise continuous, i.e. continuous within each tube, but not necessarily continuous across their boundary. Ambiguity arises because we can wrap one tube about the other through an angle $2n\pi$ without changing the mapping. Specifying the helicity of each tube individually, as well as the total helicity, will remove this difficulty. The total helicity is

$$H = \tau_1\Phi_1^2 + \tau_2\Phi_2^2 + 2L_{12}\Phi_1\Phi_2$$

(Berger 1986a). Here L_{12} measures the angle through which the tubes rotate about each other as they travel from positive to negative footpoints (averaged over the flux of the tubes). In general $L_{12} = r + n$, where $r \leq \frac{1}{2}$ is a function of the footpoint positions, and n changes by ± 1 if the tubes rotate about each other by an additional 2π . The quantity L_{12} is related to the Gauss linkage integral, in that it defines a linkage for curves with endpoints on a boundary surface. Two examples are shown in figure 3.

For three or more flux tubes, the order of braiding becomes important. For example, in figure 2 the linkage L between any two curves is zero, and yet the curves cannot be straightened out. We assume that the cross-section of each tube is simple enough to allow us to label a central field line the 'axis' of the tube. The braiding pattern of the axes can be described by finding a particularly simple configuration with the correct topology. Any braid can be placed in a unique form called a combed braid (Artin, 1950), where only one curve moves at a time (as in figure 2b). However, the configuration which minimizes the total length of the curves could be more relevant for modelling braided fields, because this configuration may approximate the pattern of the minimum magnetic energy state.

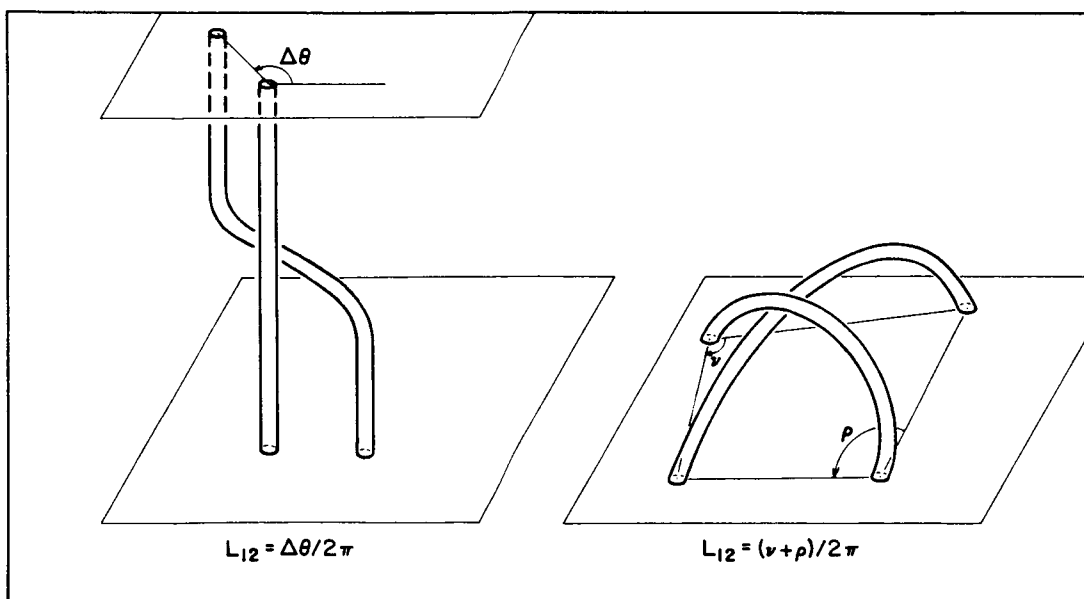

FIGURE 3

IMPLICATIONS FOR THE EXISTENCE OF SMOOTH EQUILIBRIA

Parker (1986) has shown that smooth equilibrium configurations (without current sheets) can only take very special forms. Because of this, he conjectures that very few field topologies allow smooth equilibrium solutions. Thus, as the coronal field topology evolves due to footpoint motions and reconnection, new smooth equilibria would generally be unavailable, leading to the formation of current sheets and reconnection. Examples of particular topologies which lack smooth solutions exist. For example, Low (1982) describes a two-dimensional quadrupole potential field with line tying on one boundary. If this field is distorted by continuous boundary motions, the only equilibrium solutions available consistent with the evolving footpoint distribution are potential fields with the wrong fieldline connectivity. The field contains a neutral point which is thought to collapse to a current sheet after the footpoint displacement (e.g. Sweet 1969).

Parker's assertion can be expressed in the following form: Of all possible field topologies, only a very small fraction possess smooth equilibrium configurations. This assertion has not been rigorously proven. One difficulty is that there exist infinitely many configurations corresponding to a given field topology (recall figure 2); if one configuration does not satisfy the conditions for smooth equilibrium, there conceivably might be another that does. However, topologically equivalent configurations share common features, such as the linkage numbers L between any two field lines. Such generic features might help determine the structure of possible equilibrium configurations. Here we will show that for the topology of figure 2, all possible configurations either have current sheets, or at least current layers which can be made arbitrarily thin.

Questions concerning the existence of equilibria are usually posed assuming that both the footpoint distribution and the boundary motions are continuous (van Ballegoijen 1985; Parker 1986; Zweibel and Li 1986); without continuity the formation of current sheets is trivial. Also, for simplicity the fields are assumed to stretch between two parallel planes. An initially uniform vertical field is subject to boundary motions which generate the topological structure. A result of van Ballegoijen (1985) should be mentioned in this context. Suppose we specify the transverse components of the field at one of the boundary planes. Van Ballegoijen found an ordering scheme which (within its domain of validity) can be used to obtain a smooth equilibrium configuration for the entire volume. What is not clear, however, is whether arbitrary field topologies possess equilibrium configurations that have smooth transverse fields at the boundaries. Thus the general existence of smooth equilibria for arbitrary field topologies remains unsettled.

Because of the strong localization of photospheric flux, let us model the coronal field by a collection of braided tubes, with a relatively small amount of 'intertube' flux providing continuity. In principle, the intertube flux can be made arbitrarily small. In practice, the intertube flux depends on the amount of background flux at the photosphere, the presence of sharp gradients in the photospheric velocity field, dissipative effects at the canopy level, etc. We will give an example where, in all possible configurations, the intertube flux carries substantial currents.

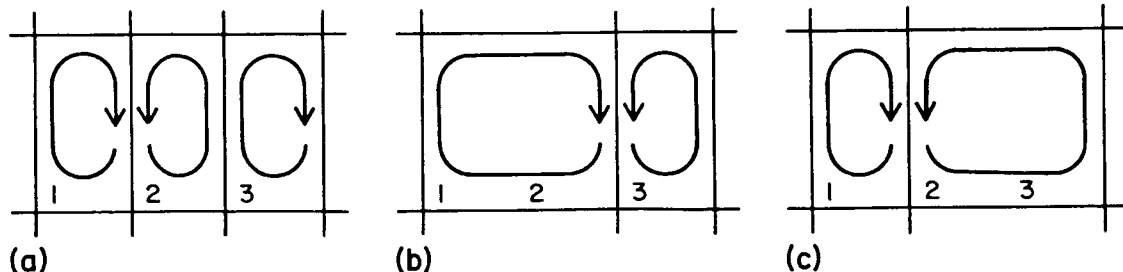

FIGURE 4

Consider an initially uniform vertical field. Subject the positive footpoints to flow patterns such as shown in figure 4. Neighboring field lines near a cell boundary diverge from each other exponentially in time, so the mapping of positive to negative footpoints will have steep but finite gradients at the cell boundaries. (I thank S. Antiochos for a discussion on this point). If the flow pattern does not change too rapidly, the

field forms approximately independent flux tubes above each cell. In figure 4a, three twisted flux tubes will be produced above the velocity cells shown, with alternating senses of twist (e.g. tube 1 will have positive helicity, 2 negative helicity, and 3 positive helicity). In figure 4b cells 1 and 2 have been combined. This flow pattern can be used to braid flux tubes 1 and 2 about each other. Figure 4c braids tubes 2 and 3. The topology of figure 2a can be produced by a sequence of six flow patterns alternating between 4b, and 4c.

Note that in figure 2 there are always pairs of tubes which, at different places in the figure, rotate both counterclockwise (+) and clockwise (-) about each other. As Parker (1986) points out, this situation creates grave difficulties for force-free fields ($\vec{J} = \alpha\vec{B}$). In particular, the condition $\vec{B} \cdot \nabla\alpha = 0$ implies that the sign of the current (which determines the sense of winding) does not change along a fieldline. We emphasize that *all possible configurations for this topology share this difficulty*: to obtain any other configuration, we must add additional braids of the tubes about each other. However, because the linking number L between any two tubes is a topological invariant, equal numbers of positive and negative twists must be added. In conclusion, the tubes themselves cannot carry the currents necessary to generate the correct field topology; these currents must instead be carried by the thin intertube flux. Unfortunately, we cannot say whether the intertube flux can itself satisfy the conditions for smooth (or stable!) equilibrium.

In conclusion, the fields in active regions to some approximation may resemble a collection of highly braided flux tubes, with only a small amount of flux in between. The topology of the braided tubes can be precisely described. If the example of figure 2 has any generality, then thin current layers, if not singular current sheets must inevitably form between the tubes. The braiding structure cannot be dissipated except by reconnection across these current layers. It is important to know for certain whether the layers have zero or finite thickness, because the width of the current layers can affect the dissipation timescale.

I thank B.C. Low, Aad van Ballegooijen, Spiro Antiochos, Gene Parker and Ellen Zweibel for clarifying discussions. The National Center for Atmospheric Research is supported by the National Science Foundation.

- Artin, E. 1950, "The Theory of Braids," *Am. Scientist* **38**, (112).
- Berger, M.A. 1986a, "Topological Invariants of Field Lines Rooted to Planes," *Geophys. Astrophys. Fluid Dyn.* **34**, (265).
- Berger, M.A. 1986b, "Braiding of Magnetic Flux by Two-Dimensional Random Boundary Motions," *preprint*.
- Berger, M.A. and G.B. Field 1984, "The Topological Properties of Magnetic Helicity," *J. Fluid Mech.* **147**, (133).
- Frazier, E.N. and Stenflo, J.O. 1972, "On the Small Scale Structure of Solar Magnetic Fields," *Solar Phys.* **27**, (330).
- Low, B.C. 1982, "Nonlinear Force-Free Magnetic Fields," *Rev. Geophys. Space Phys.* **20**, (145).
- Low, B.C. 1985, "Modelling Solar Magnetic Structures," in *Measurements of Solar Vector Magnetic Fields*, NASA Conf. Publ. 2374 (M.J. Hagyard, ed.), (49).
- Moffatt, H.K. 1969, "The Degree of Knottedness of Tangled Vortex Lines," *J. Fluid Mech.* **35**, (117).
- Parker, E.N. 1972, "Topological Dissipation and the Small-Scale Fields in Turbulent Gases," *Ap. J.* **174**, (499).
- Parker, E.N. 1983, "Magnetic Neutral Sheets in Evolving Fields, II. Formation of the Solar Corona," *Ap. J.* **264**, (642).
- Parker, E.N. 1986, "Equilibrium of Magnetic Fields with Arbitrary Interweaving of the Lines of Force I. Discontinuities in the Torsion," *Geophys. Astrophys. Fluid Dyn.* **34**, (243).
- Sturrock, P.A. and Y. Uchida 1981, "Coronal Heating by Stochastic Magnetic Pumping," *Ap. J.* **246**, (331).
- Sweet, P.A. 1969, "Mechanisms of Solar Flares," *Ann. Rev. Astron. Astrophys.* **7**, (149).
- van Ballegooijen, A.A. 1985, "Electric Currents in the Solar Corona and the Existence of Magnetostatic Equilibrium," *Ap. J.* **298**, (421).
- van Ballegooijen, A.A. 1986, "Cascade of Magnetic Energy as a Mechanism of Coronal Heating," *preprint*.
- Yang, W.H., P.A. Sturrock, and S.K. Antiochos 1986, "Force-free Magnetic Fields: the Magneto-Frictional Method," *preprint*.
- Zweibel, E.G. and H.S. Li 1986, "The Formation of Current Sheets in the Solar Atmosphere," *preprint*.