Experimental Determination of the Stable-Trim Attitudes of Two Proposed, General- Purpose, Heat-Source Modules.

Robert L. Kruse

(NASA-TM-88345) EXPERIMENTAL DETERMINATION
OF THE STABLE-TRIM ATTITUDES OF TWO
PROPOSED, GENERAL-PURPOSE, HEAT-SOURCE
MODULES (NASA) 25 p

CSSL 01A

N87-20967

Unclas

G3/02 43586

May 1987



National Aeronautics and
Space Administration

Experimental Determination of the Stable-Trim Attitudes of Two Proposed, General- Purpose, Heat-Source Modules.

Robert L. Kruse, Ames Research Center, Moffett Field, California

May 1987



National Aeronautics and
Space Administration

Ames Research Center
Moffett Field, California 94035

SYMBOLS

- A reference area (largest face of model)
- C_D drag coefficient
- C_{m_α} pitching-moment curve slope
- I_x, I_y, I_z moment of inertia about the X, Y, and Z axis through the center of gravity
- l reference length
- m model mass
- p static pressure
- Re_l Reynolds number based on free-stream properties and model reference length
- X, Y, Z model inertial axes; also, tunnel-fixed reference axes, and displacements along these axes
- α angle of attack, angle projected onto the vertical plane between the model longitudinal axis and stream direction
- α_r resultant angle of attack, $\tan^{-1} \sqrt{\tan^2 \alpha + \tan^2 \beta}$
- α_{rms} root-mean-square resultant angle of attack, $\left(\frac{\int_0^x \alpha_r^2 dx}{x} \right)^{1/2}$
- β angle of sideslip, angle projected onto the horizontal plane between the model longitudinal axis and stream direction

PRECEDING PAGE BLANK NOT FILMED

SUMMARY

Ballistic range tests have been conducted to determine the aerodynamically stable trim attitudes of two proposed general-purpose heat-source module configurations. Tests were conducted at speeds of 4.6 km/sec for the concept module, and at both 4.6 km/sec and 1.4 km/sec for the MOD II. Test results indicated that both configurations were stable when launched in the "face-on" attitude. When launched in the "side-on" attitude, the MOD II configuration was found to be stable, while tests of the concept module did not give definitive results.

INTRODUCTION

With so many different types of satellites and spacecraft planned for use in the near future, a need has arisen to develop a heat-source module for general use with spacecraft power systems (refs. 1-3; also, "Fletcher Gives Projection of Space Program Future," Dr. James C. Fletcher NASA Activities, Dec, 15, 1973). The module will incorporate radioactive material as its heat source. In the event of a catastrophic failure of the spacecraft, the heat-source module must remain intact during atmospheric entry. To ensure this, the stable, aerodynamic trim attitudes of the module must be known so that it can be thermally protected to survive reentry.

The development of such a heat-source module is being conducted by the University of California at the Los Alamos Scientific Laboratory, in Los Alamos, New Mexico. In support of their development, tests were conducted in the NASA Ames-Moffett Research Center Ballistic Range Facilities to determine the stable trim attitudes of two proposed modules.

MODELS

A sketch of one of the configurations used in the present investigation, the concept module, is shown in figure 1. This first model was launched in the "face-on" attitude as shown in figure 1, and also in the "side-on" attitude as shown in the photograph of figure 2, which also shows a typical sabot used to launch the models. The second model, the MOD II, is shown in figure 3. As shown, the corners which were eliminated for the concept module have been retained in the simpler configuration. All models were constructed of aluminum with the center of gravity located at the geometric center by hollowing out some of the model at the model base. The axis systems used with the different configurations and orientations are shown in figure 4.

TESTS

The tests were conducted in free flight in the Ames Research Center Ballistic Range Facilities using the Hypervelocity Free-Flight Aerodynamic Facility (HFFAF) and the Pressurized Ballistic Range (PBR). The HFFAF has 16 orthogonal spark-shadowgraph stations spaced evenly over its 23-m length. Test models were launched in the HFFAF facility at 4.6 km/sec from a 25.4-mm, deformable-piston, light-gas gun. The PBR has 24 orthogonal spark-shadowgraph stations irregularly spaced over its 62-m length. Test models were launched in the PBR facility at 1.4 km/sec from a 44.4-mm, powder-gas gun.

The Reynolds number was selected to match that which the module is predicted to experience at peak heating; i.e., 260,000 based on λ . (figs. 1 and 3).

DATA REDUCTION

The primary purpose of the investigation was to determine the stable trim attitudes of these configurations. A secondary purpose was to obtain quantitative aerodynamic coefficients from analysis of the test records. These aerodynamic data were obtained using the data-reduction program described in reference 4. This program obtains drag data from the time-distance history of the model, and static stability from the oscillatory motion of the model. For tests in which the model tumbled, only drag data were obtained.

The equations of motion used in this program are for axisymmetric configurations in oscillatory flight. The present configurations, however, are not axisymmetric. For a model in oscillatory flight, the roll orientation could very likely influence the oscillatory characteristics of the model.

Any effect of roll position cannot be handled by the data-reduction program of reference 4; consequently, there could be some uncertainty in the results. The drag data, which is determined from the time-distance history of the model, would be least affected, with the uncertainty approximately $\pm 1\%$. The static-stability data from flights in which the model was launched face-on would have an uncertainty of approximately $\pm 5\%$. For the data from tests in which the model was launched side-on, the roll orientation would have the greatest influence. The uncertainty in the static stability data in this case would be approximately $\pm 25\%$. In spite of this limitation, the ballistic-range test results reported herein are able to answer the primary question: at what trimmed attitudes are the configurations statically stable?

RESULTS AND DISCUSSION

The initial tests were conducted in the Ames Research Center HFFAF with models of the concept module launched in the face-on attitude at velocities near 4.6 km/sec.

A summary of the test results is presented in Table 1. The aerodynamic data deduced from these tests and the physical characteristics of the models are presented in Table 2. In two of the tests (1445 and 1446), the models experienced relatively small amplitude oscillations about the face-on attitude over the length of the range. Plots of these motions are shown in figures 5(a) and 5(b), and a shadowgraph from one of the tests (1445) is shown in figure 5(c). These results indicate that the configuration is statically stable about an angle of attack close to 0° (face-on) at these test conditions. One of the tests (1450) was conducted at increased range pressure to obtain more model motion during the flight. This motion, shown in figure 5(d), gives results similar to those just described; however, the trim angle of attack appears to be a little higher, about 2° to 3° .

Tests were also conducted on models launched in the side-on attitude. The model motion of one of these tests (1459) is shown in figure 5(e). During the test, the model reached its maximum angle of attack early in the flight, then decreased, possibly indicating a stable flight. However, during the latter part of the flight, the resultant angle of attack increased in a manner unlike that of a statically stable configuration. Consequently, it is not possible to say with any degree of certainty whether this motion indicated a stable or unstable flight. In a subsequent test (1473), the model was again launched side-on. The α vs. β plot of this flight (fig. 5(f)) does not give any indication of a stable side-on flight. The resultant angle of attack increases greatly during the flight, and there is no indication of an attempt to orient to the face-on position. It is of interest that the resultant angle of attack at station 1 of this test and the previous test was about the same. It appears, therefore, that the model disturbance at launch was appreciably greater in the latter test.

Four tests were conducted with MOD II models launched in the side-on attitude. In two of the tests (1520 and 1521), the models reoriented to the face-on attitude. The motions are shown in figures 6(a) and 6(b), respectively. This result is significant because this type of motion has not been previously observed. The model in test 1521 lost its base-mounting screw, probably because of the shock of the launch, but the model did not appear to be damaged. The motion of another test (1523) using the MOD II design is shown in figure 6(c). There is an indication that the model could be flying statically stable at the launch attitude; i.e., the resultant angle of attack increases slightly, then decreases. However, similar to the results of test 1459 (fig. 5(e)), there is hardly enough motion to define the type of flight with any degree of certainty. Figures 6(d) and 6(e) display the results of another MOD II test (1524). The model trimmed at approximately 12°

from the launch attitude and made nearly a full cycle of oscillation during its flight. The result of this test gives a strong indication that this configuration is statically stable in the side-on orientation.

The model in test 1525 was launched face-on and flew in that attitude the length of the range. An α -versus- β plot of this flight is shown in figure 6(f) and a shadowgraph of the model in flight shown in figure 6(g).

The final tests were conducted in the PBR with models of the MOD II configuration. Tests in this facility, with its longer test section, can better determine the type of motion experienced by the model. In two of the tests (1816 and 1817), the models were launched in the side-on attitude, and during both tests the models tumbled. In test 1818, the model flew an oscillating flight, making nearly two cycles over the length of the range. This motion is shown in figure 7(a). From this data and the shadowgraphs (fig. 7(b)) it was determined that the motion was largely about the I_x axis. The model was launched face-on (test 1819) and trimmed in that attitude for its flight during the length of the range. The motion and shadowgraph are shown in figures 7(c) and 7(d), respectively. The results of these latter two tests (1818 and 1819) show without question that the MOD II configuration is statically stable in two different orientations.

CONCLUDING COMMENTS

Ballistic-range tests have shown that both configurations, the concept module and MOD II, will trim and be statically stable in the face-on orientation. When launched in the side-on attitude, the resulting motions of the configurations appeared to be very sensitive to the magnitude of the disturbance during sabot separation; i.e., the models either tumbled, attempted to reorient themselves to a face-on attitude, or were stable.

REFERENCES

1. Editor-in-Chief, John Newbauer, Venus and Mars Spacecraft Programs. *Astronautics and Aeronautics*, Sept. 1973. p. 81.
2. Rasool, S.I.; Long, J.E.; and Naugle, J.E.: Exploring Jupiter, Saturn, and their Satellites. *Astronaut. Aeronaut.* Oct. 1973. p. 26.
3. Editor-in-Chief, John Newbauer, Space System Summaries. *Astronaut. Aeronaut.* Feb. 1974, p. 79.
4. Malcolm, Gerald N.; and Chapman, G. T.: A Computer Program for Systematically Analyzing Free-Flight Data to Determine the Aerodynamics of Axisymmetric Bodies. NASA TN D-4766, 1968.

TABLE 1.- TEST SUMMARY

MODEL TYPE	FACILITY	LAUNCH ATTITUDE	TEST NO.	VELOCITY, km/sec	Re_{ℓ} , $\times 10^{-3}$	p, mbar	TYPE OF FLIGHT
CONCEPT MODULE	HFFAF	FACE ON	1445	4.77	273	59.2	TRIMMED, STATICALLY STABLE FLIGHT
			1446	4.82	273	58.9	
			1450	4.22	706	174.0	
		SIDE ON	1459	4.74	267	60.0	NOT DEFINITIVE
1473	4.77		273	60.4			
MOD II	HFFAF	SIDE ON	1520	4.76	250	60.1	REORIENT TO FACE ON REORIENT TO FACE ON NOT DEFINITIVE STABLE
			1521	4.64	242	60.4	
			1523	4.80	246	60.0	
			1524	4.54	523	134.0	
		FACE ON	1525	4.55	234	60.0	STABLE
	PBR	SIDE ON	1816	0.87	178	154.0	TUMBLED
			1817	1.22	202	124.0	TUMBLED
1818			1.32	218	127.0	STABLE	
FACE ON	1819	1.26	207	126.0	STABLE		

TABLE 2.- AERODYNAMIC AND MODEL DATA

MODEL TYPE	TEST NO.	AERODYNAMIC DATA				MODEL DATA					
		C _D	-C _{mα}	α _{rms} , deg	MASS, g	I _x × 10 ⁸ , kg m ²	I _y × 10 ⁸ , kg m ²	I _z × 10 ⁸ , kg m ²	ℓ, cm	A, cm ²	
CONCEPT MODULE	1445	1.56	0.094	6.1	5.0942	17.29	11.85	11.85	1.501	2.125	
	1446	1.51	0.079	13.1	5.1003	17.41	11.99	11.99	1.501	2.126	
	1450	1.56	0.099	5.1	5.0926	17.52	12.07	12.07	1.499	2.122	
	1459	0.814	-	19	5.0959	17.44	11.95	11.95	1.498	2.121	
	1473	0.764	-	64	5.1186	17.74	12.01	12.01	1.499	2.125	
MOD II	1520	1.62	-	30.6	3.7630	11.40	7.34	7.54	1.361	1.819	
	1521	1.59	-	25.4	3.7640	11.36	7.29	7.50	1.361	1.823	
	1523	0.97	-	19.7	3.7706	11.51	7.46	7.54	1.362	1.823	
	1524	0.96	0.024	16.7	3.7738	11.55	7.50	7.56	1.361	1.824	
	1525	1.73	0.126	5.3	3.7345	11.40	7.34	7.54	1.356	1.816	
PBR	1816	1.11	-	TUMBLER	12.5690	85.47	55.19	55.53	2.032	4.075	
	1817	0.96	-	TUMBLER	12.5334	84.87	55.24	56.49	2.032	4.069	
	1818	0.94	0.031	9.92	12.5580	85.67	54.57	56.25	2.033	4.074	
	1819	1.71	0.142	8.11	12.5581	85.39	55.57	57.49	2.033	4.076	

ORIGINAL PAGE IS
OF POOR QUALITY

ORIGINAL PAGE IS
OF POOR QUALITY

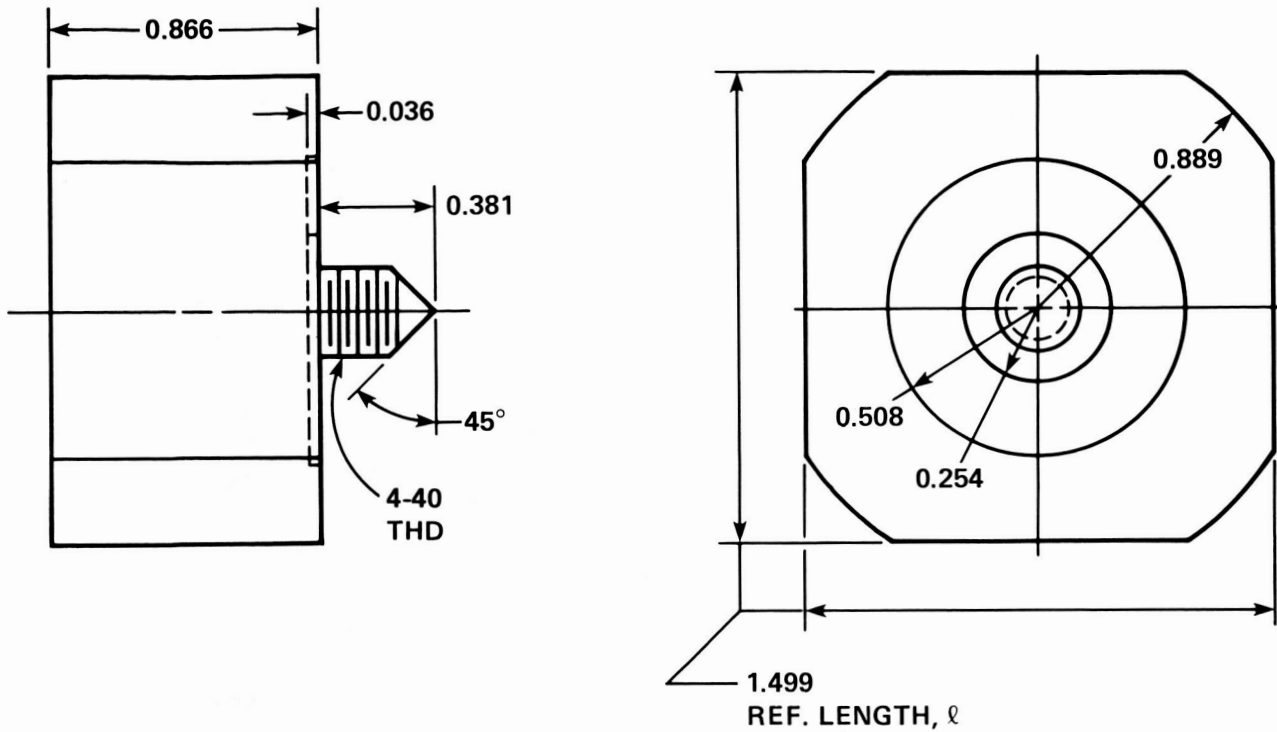

Figure 1.- Concept-module model.

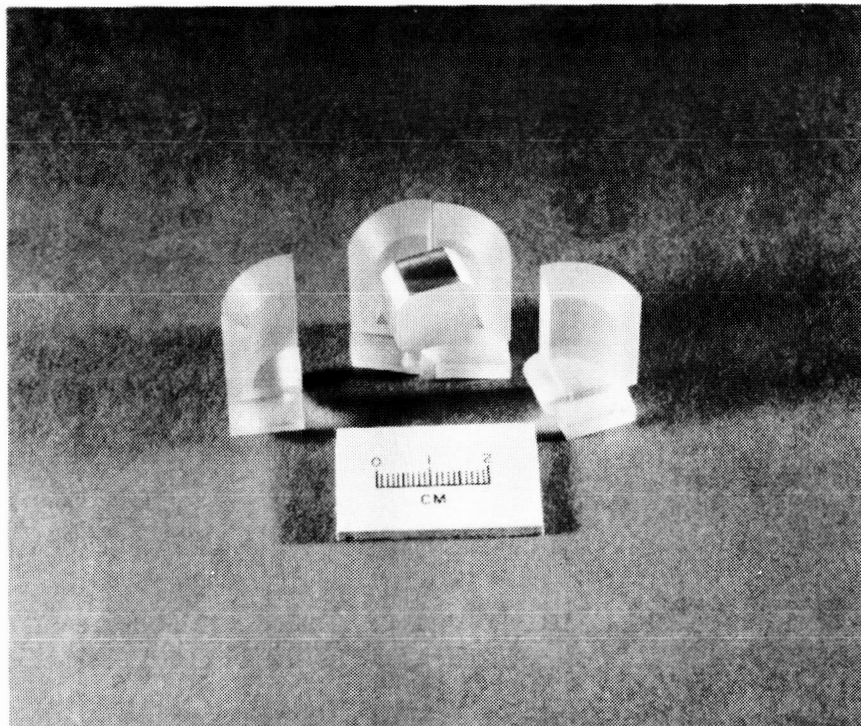

Figure 2.- Concept-module model and sabot.

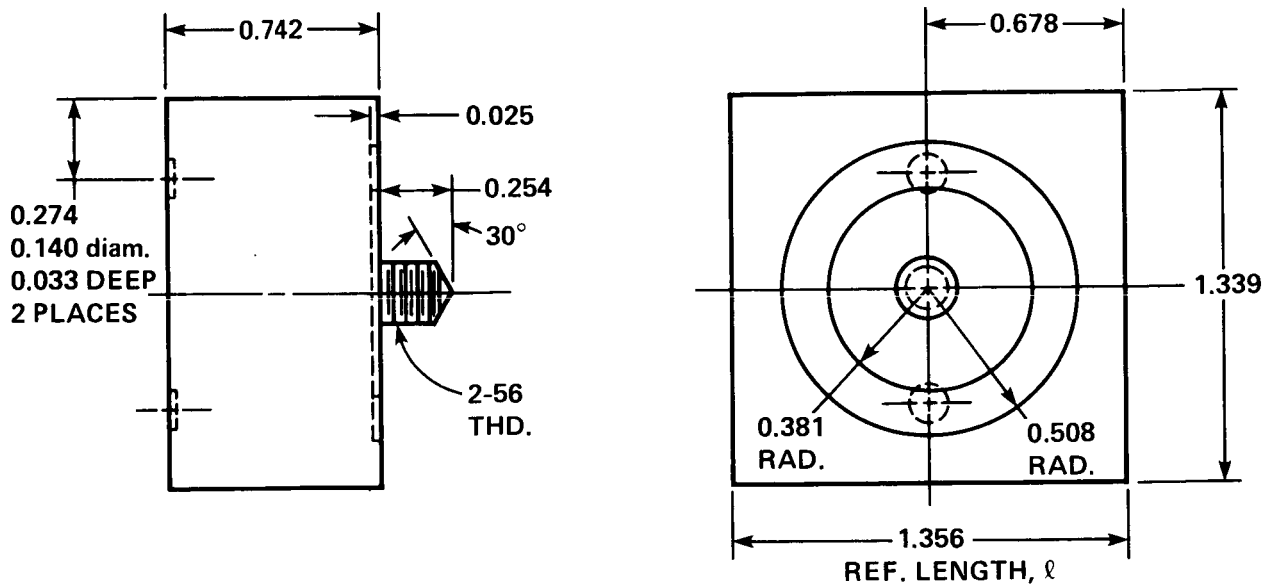

Figure 3.- MOD II model.

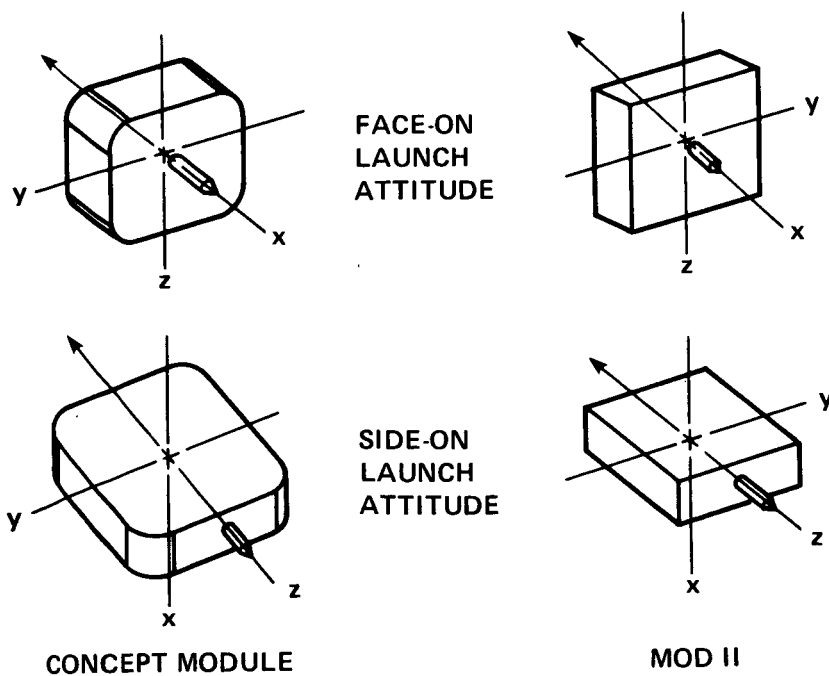
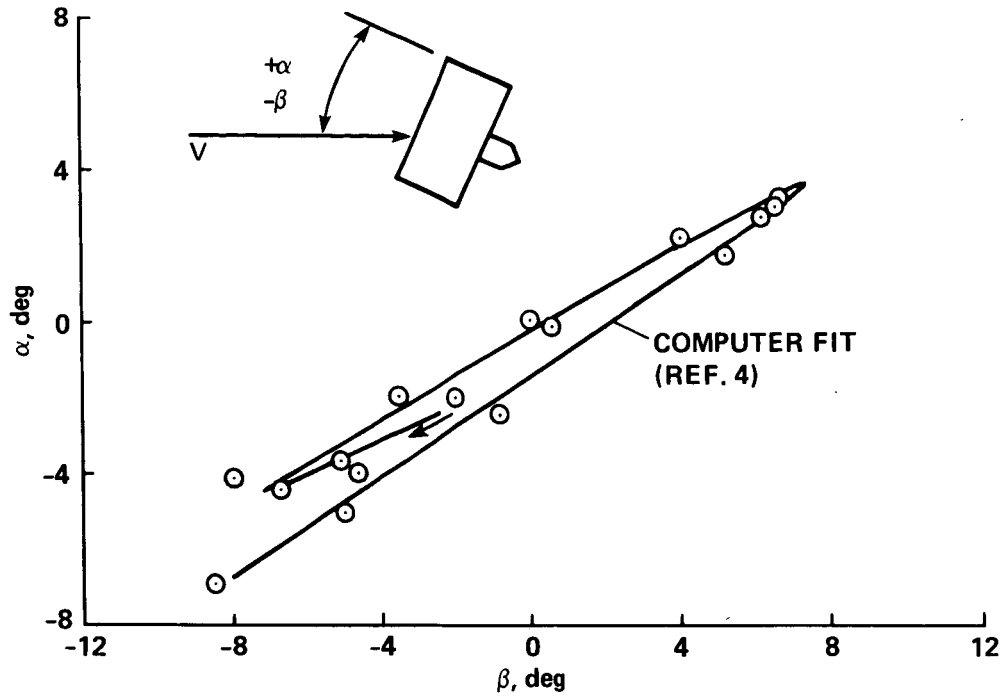
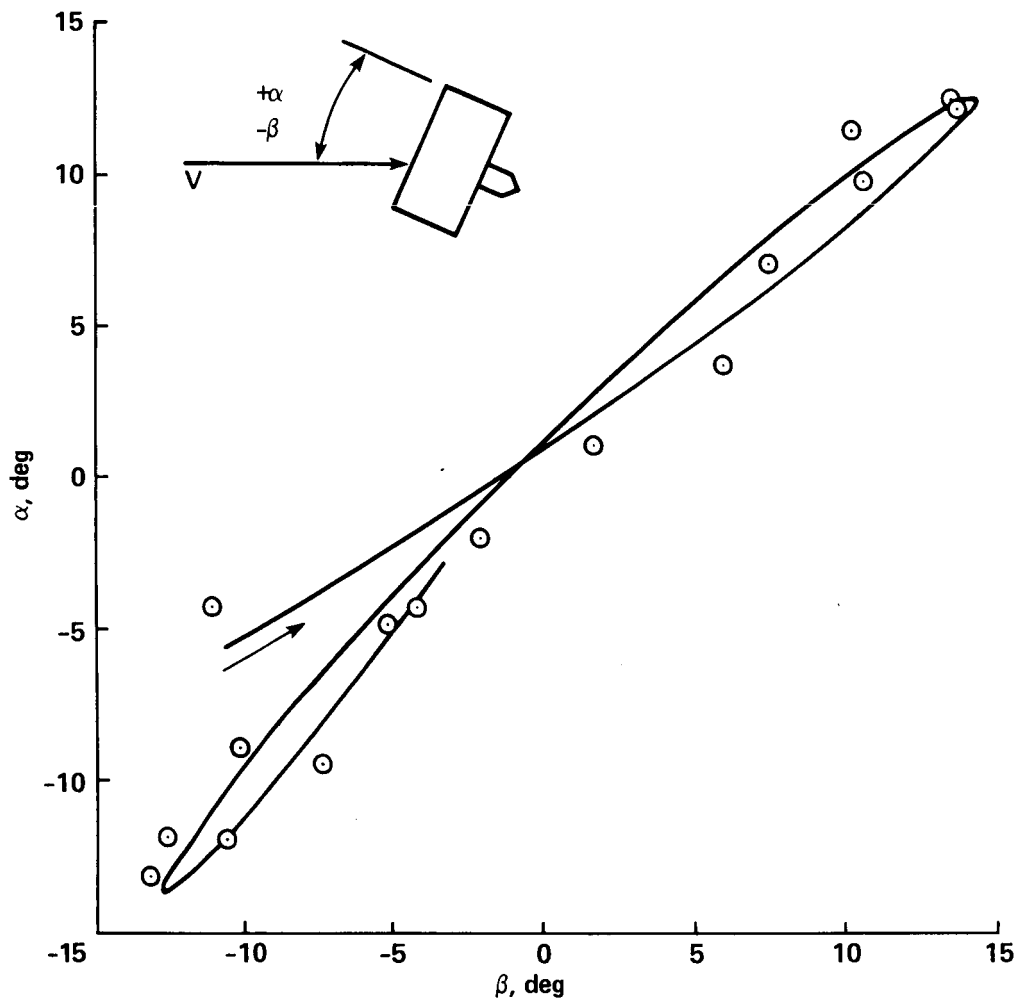

Figure 4.- Model inertial axes.



(a) Angular motions, test 1445.

Figure 5.- Concept-module-model test results, HFFF.



(b) Angular motions, test 1446.

Figure 5.- Continued.

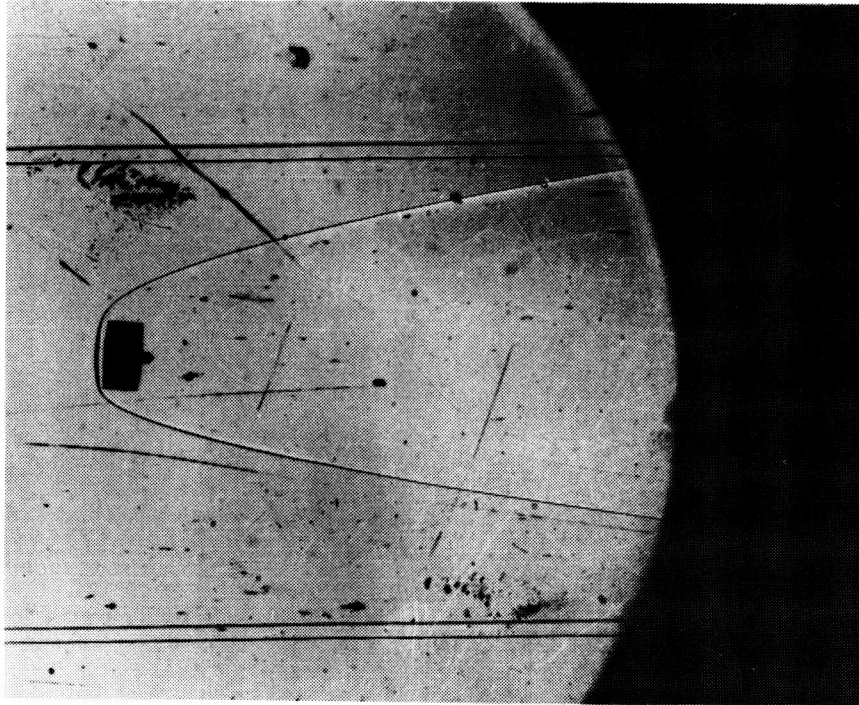

(c) Shadowgraph of model in flight, test 1445.

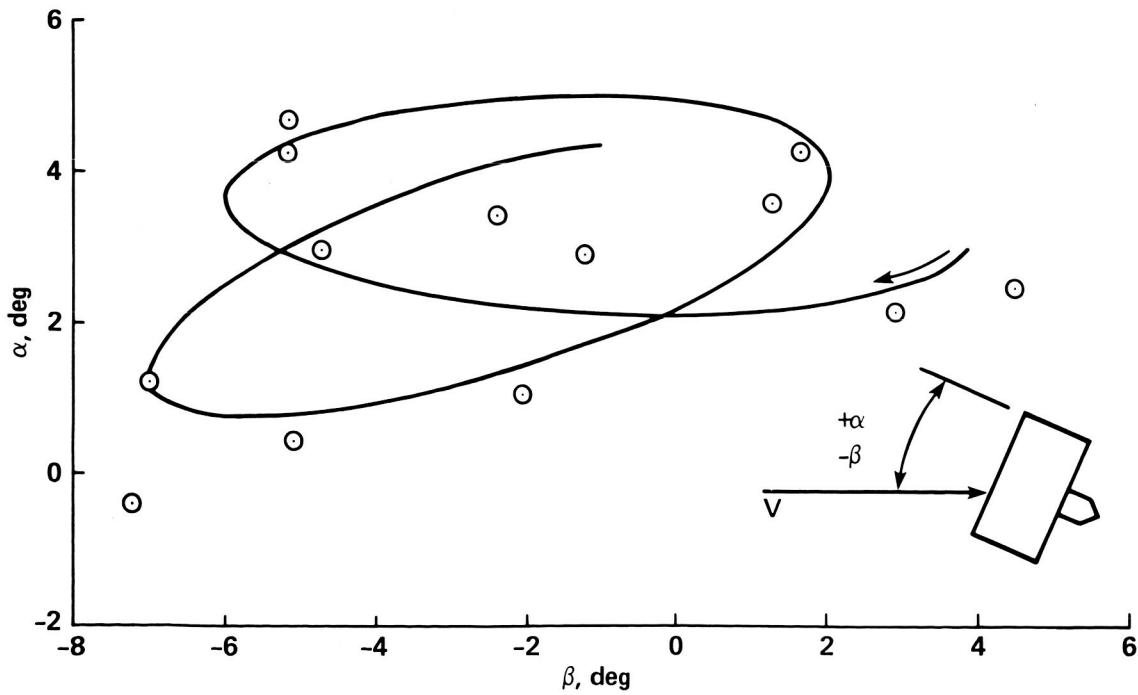

(d) Angular motions, test 1450.

Figure 5.- Continued.

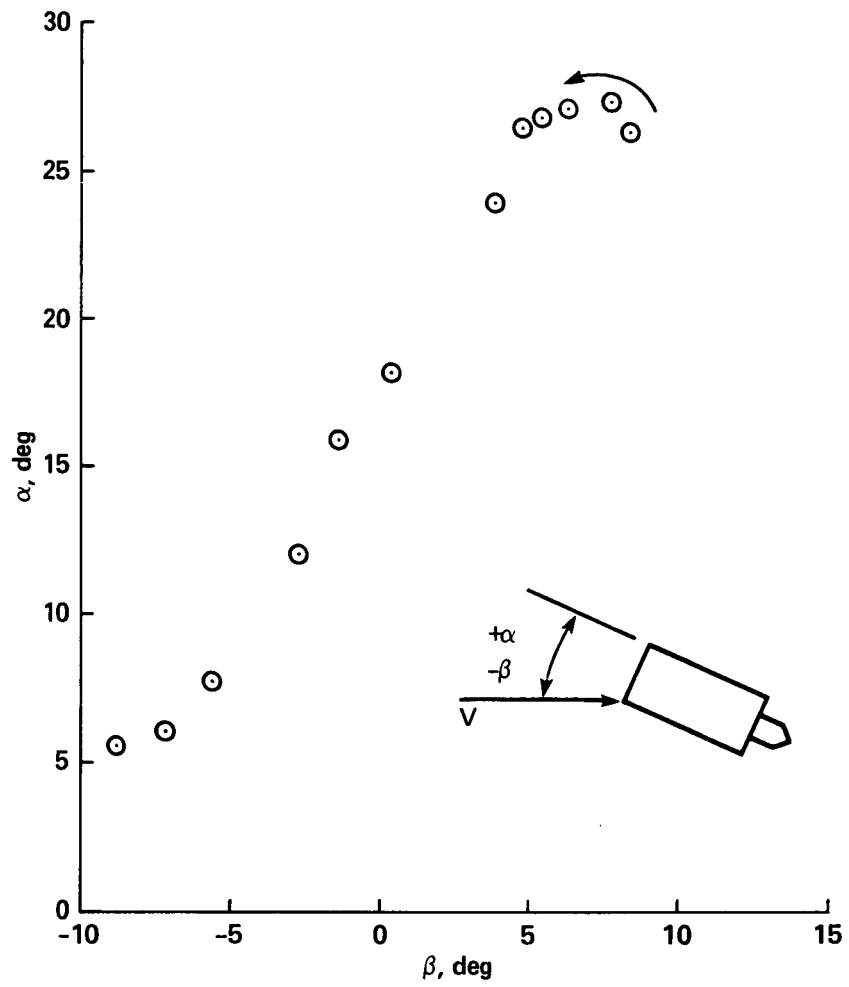

(e) Angular motions, test 1459.

Figure 5.- Continued.

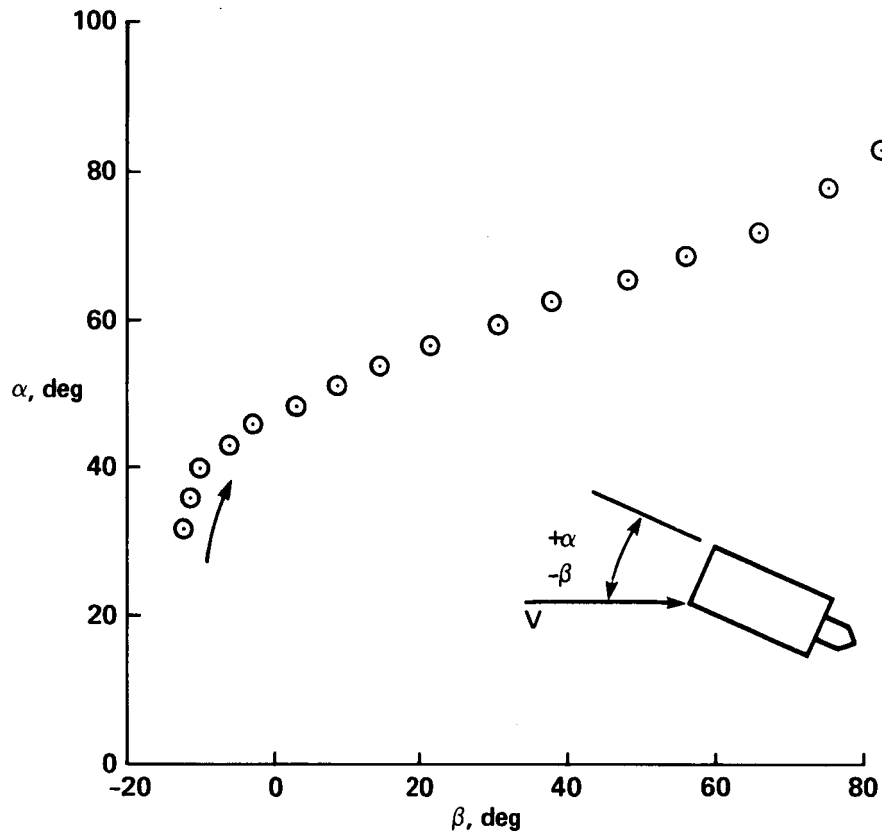

(f) Angular motions, test 1473.

Figure 5.- Concluded.

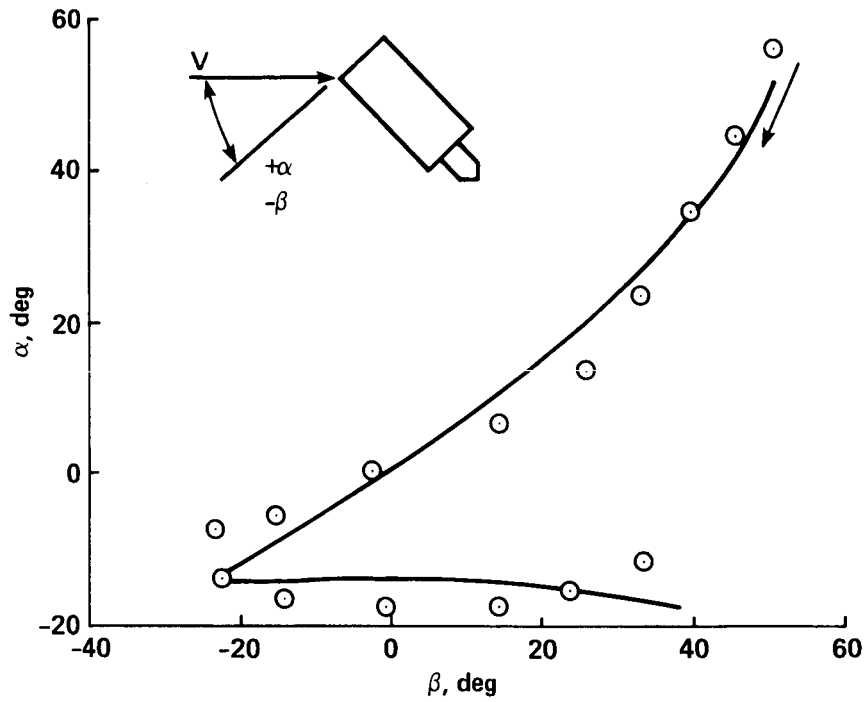

(a) Angular motions, test 1520.

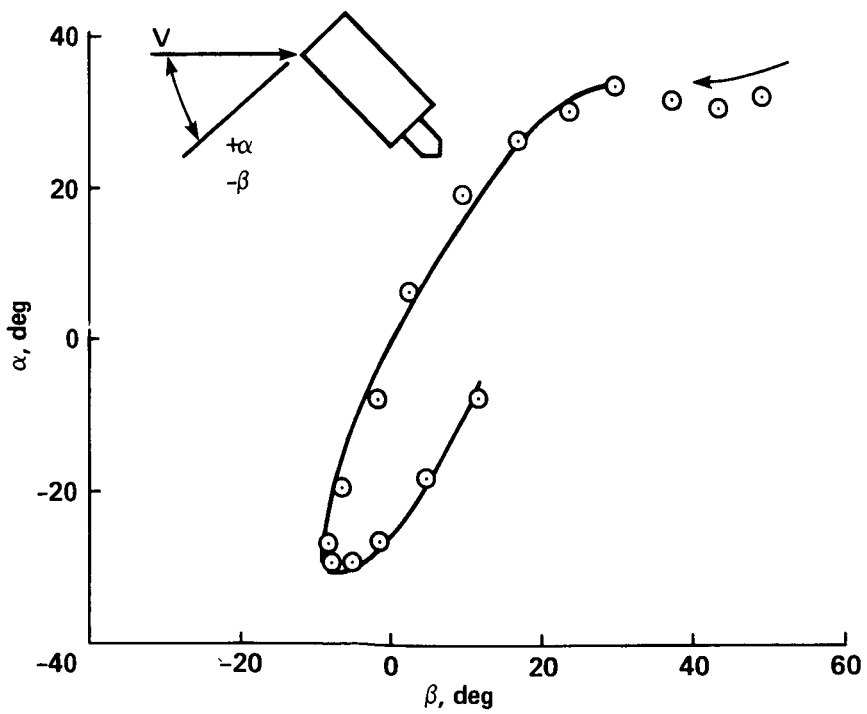

(b) Angular motions, test 1521.

Figure 6.- MOD-II-model test results, HFFF.

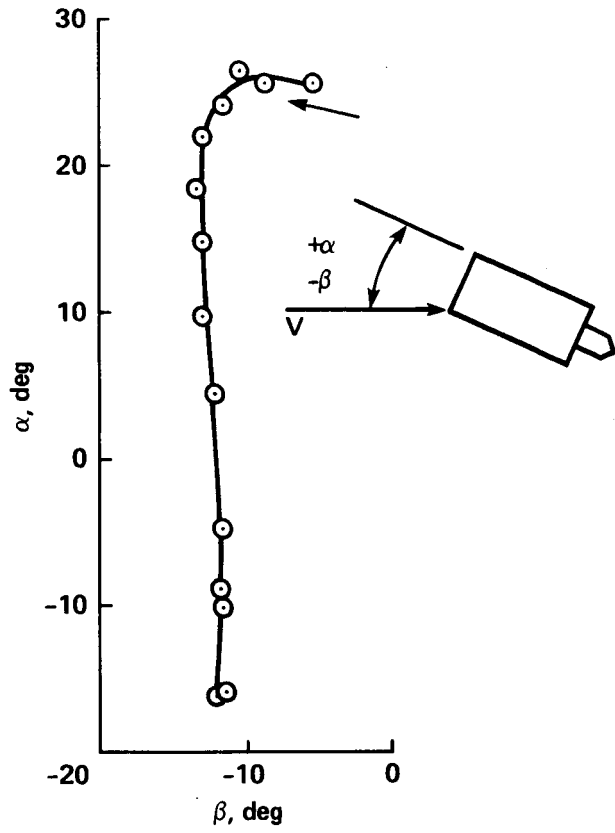

(c) Angular motions, test 1523.

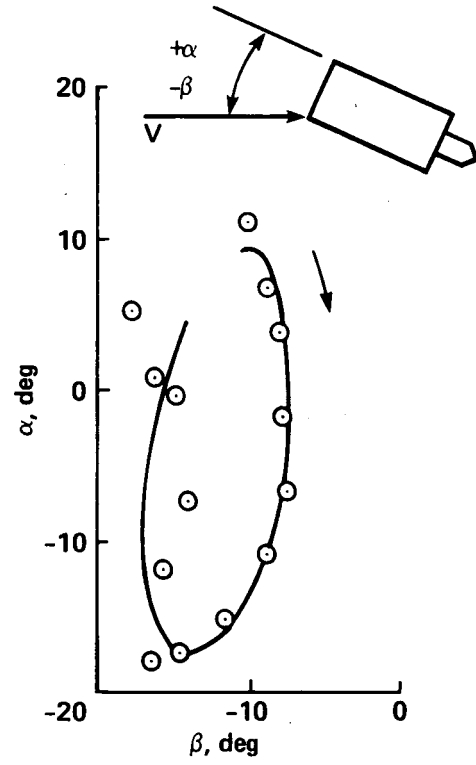

(d) Angular motions, test 1524.

Figure 6.- Continued.

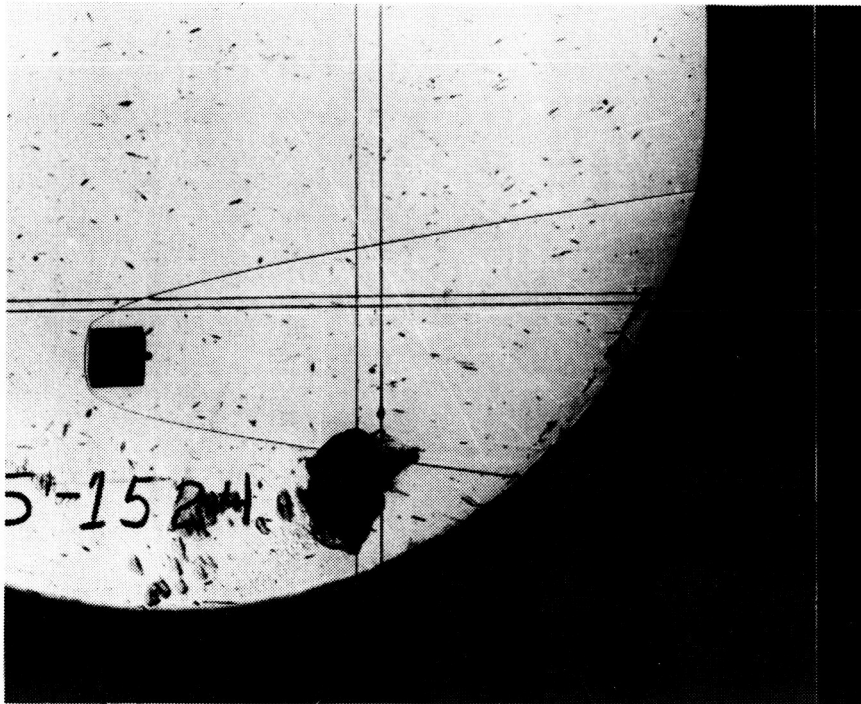

(e) Shadowgraph of model in flight, test 1524.

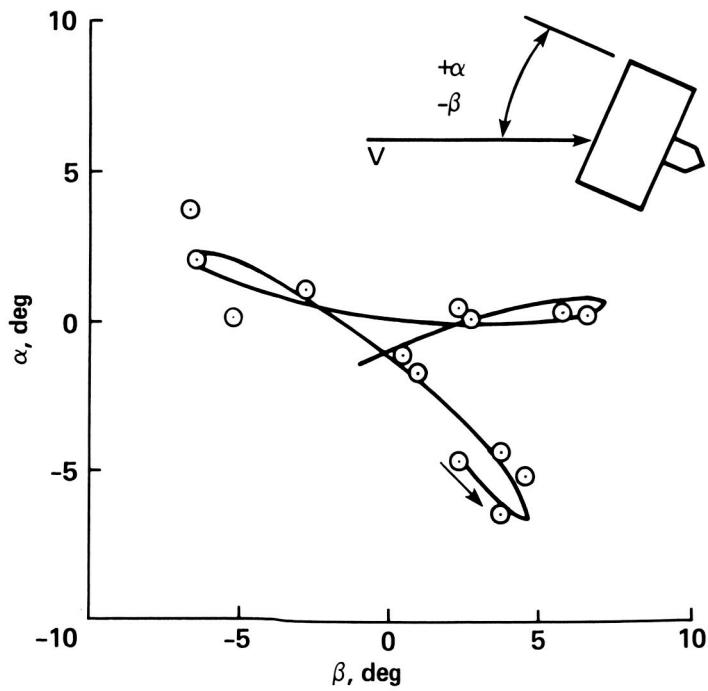

(f) Angular motions, test 1525.

Figure 6.- Continued.

ORIGINAL PAGE IS
OF POOR QUALITY

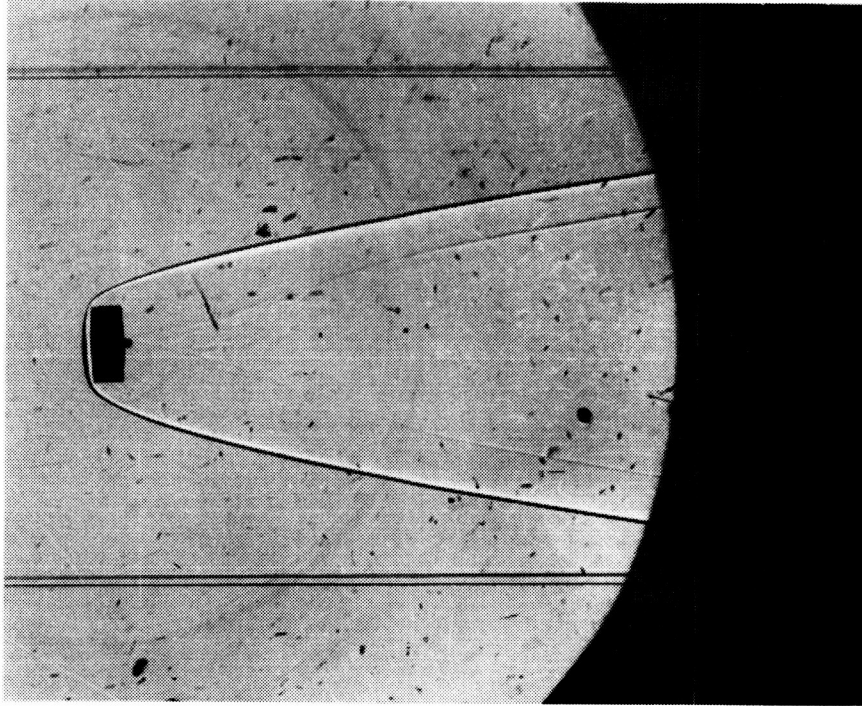

(g) Shadowgraph of model in flight, test 1525.

Figure 6.- Concluded.

ORIGINAL PAGE IS
OF POOR QUALITY

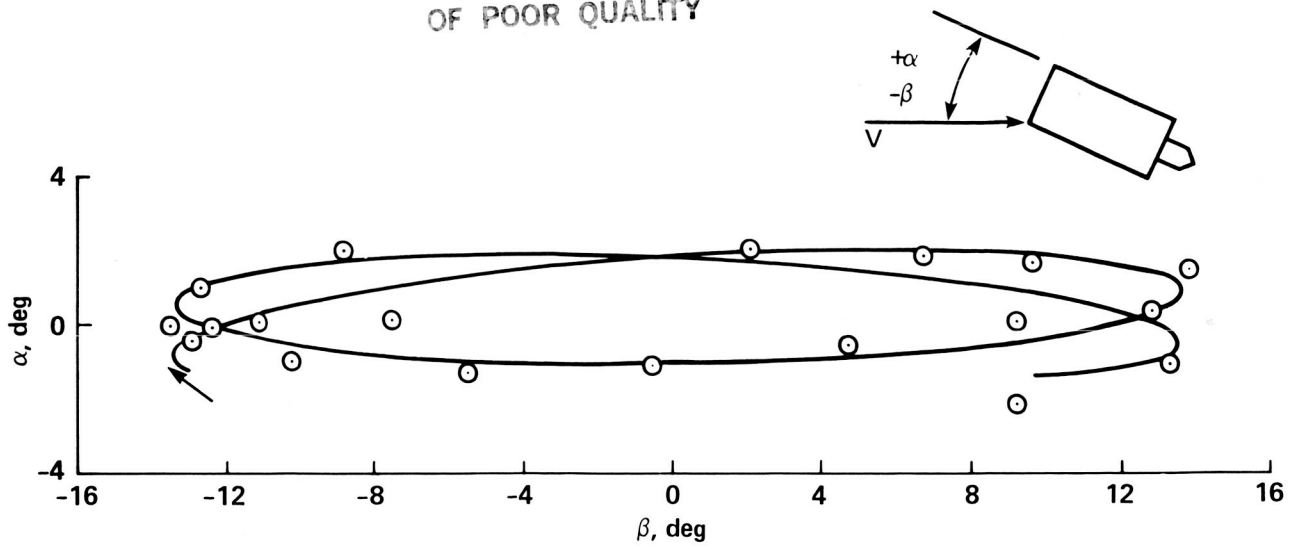

(a) Angular motions, test 1818.

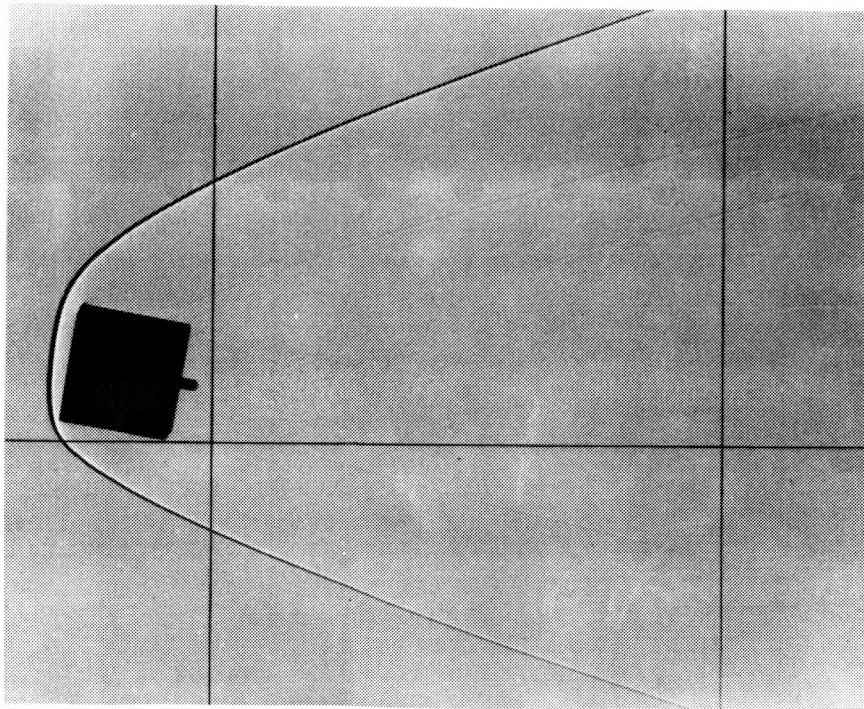

(b) Shadowgraph of model in flight, test 1818.

Figure 7.- MOD-II-model test results, PBR.

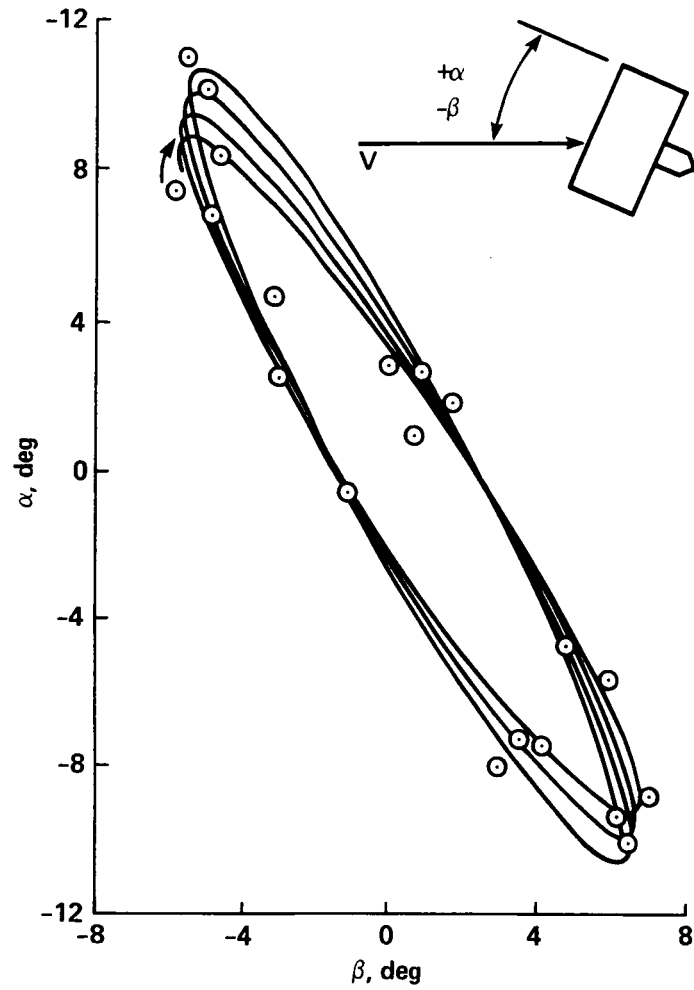

(c) Angular motions, test 1819.

Figure 7.- Continued.

ORIGINAL PAGE IS
OF POOR QUALITY

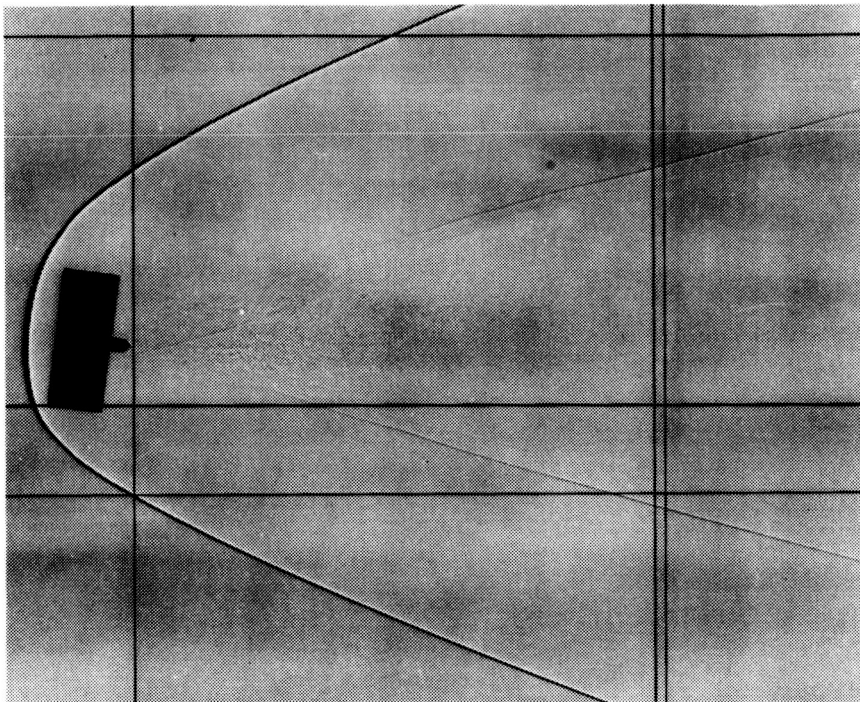

(d) Shadowgraph of model in flight, test 1819.

Figure 7.- Concluded.



Report Documentation Page

1. Report No. NASA TM-88345		2. Government Accession No.		3. Recipient's Catalog No.	
4. Title and Subtitle Experimental Determination of the Stable-Trim Attitudes of Two Proposed, General-Purpose, Heat-Source Modules				5. Report Date May 1987	
				6. Performing Organization Code	
7. Author(s) Robert L. Kruse				8. Performing Organization Report No. A-86368	
				10. Work Unit No. 505-40-11	
9. Performing Organization Name and Address Ames Research Center Moffett Field, CA 94035				11. Contract or Grant No.	
				13. Type of Report and Period Covered Technical Memorandum	
12. Sponsoring Agency Name and Address National Aeronautics and Space Administration Washington, DC 20546				14. Sponsoring Agency Code	
				15. Supplementary Notes Point of Contact: Robert L. Kruse, Ames Research Center, M/S 237-1 Moffett Field, CA 94035 (415) 694-6094 or FTS 464-6094	
16. Abstract Ballistic range tests have been conducted to determine the aerodynamically stable trim attitudes of two proposed general-purpose heat-source module configurations. Tests were conducted at speeds of 4.6 km/sec for the concept module, and at both 4.6 km/sec and 1.4 km/sec for the MOD II. Test results indicated that both configurations were stable when launched in the "face-on" attitude. When launched in the "side-on" attitude, the MOD II configuration was found to be stable, while tests of the concept module did not give definitive results.					
17. Key Words (Suggested by Author(s)) Stable trim attitude Aerodynamics Blunt bodies			18. Distribution Statement Unclassified-Unlimited Subject Category - 02		
19. Security Classif. (of this report) Unclassified		20. Security Classif. (of this page) Unclassified		21. No. of pages 24	22. Price A03