

N87-22204

## CALCULATING ROTORDYNAMIC COEFFICIENTS OF SEALS

## BY FINITE-DIFFERENCE TECHNIQUES

F.J. Dietzen and R. Nordmann  
 University of Kaiserslautern  
 Kaiserslautern, Federal Republic of Germany

For modelling the turbulent flow in a seal the Navier-Stokes equations in connection with a turbulence model ( $k$ - $\epsilon$ -model) are solved by a finite-difference method. A motion of the shaft round the centered position is assumed. After calculating the corresponding flow field and the pressure distribution, the rotordynamic coefficients of the seal can be determined. These coefficients are compared with results obtained by using the bulk flow theory of Childs [1] and with experimental results.

## INTRODUCTION

It is well known that the fluid forces in seals, which are described by equation (1)

$$- \begin{bmatrix} F_z \\ F_y \end{bmatrix} = \begin{bmatrix} K & k \\ -k & K \end{bmatrix} \cdot \begin{bmatrix} z \\ y \end{bmatrix} + \begin{bmatrix} D & d \\ -d & D \end{bmatrix} \cdot \begin{bmatrix} \dot{z} \\ \dot{y} \end{bmatrix} + \begin{bmatrix} M & m \\ -m & M \end{bmatrix} \cdot \begin{bmatrix} \ddot{z} \\ \ddot{y} \end{bmatrix} \quad (1)$$

have a strong influence on the dynamic behaviour of rotating turbo-machinery. While there exist some good theories for calculating the coefficients of straight seals [1], no satisfactory model is known to describe the effects of grooved seals. Reference [2] presents a survey and comparison of results of existing theories. The authors' opinion is that the existing methods are not at all satisfactory. The main weakness of these theories is the fact, that they are using so called 'bulk-flow-theories' which connect the wall shear stress with the mean flow-velocity relative to this wall. However, in the region of a groove there occur stresses in the fluid which cannot be neglected. Calculating the flow by using the Navier-Stokes equations in connection with a turbulence model eliminates this disadvantage. Therefore, a finite difference model is presented which allows the calculation of the coefficients by using these equations.

## Nomenclature:

$F_z, F_y$	Forces on the shaft in z and y direction
$K, k$	direct and cross-coupling stiffness in eq. (1, 24)
$D, d$	direct and cross-coupling damping in eq. (1,24)
$M, m$	direct and cross-coupling inertia in eq. (1, 24)
$u, v, w$	axial, radial and circumferential velocity
$p$	pressure
$k$	turbulence energy
$\varepsilon$	energy dissipation
$\mu_e, \mu_l, \mu_t$	effective, laminar and turbulent viscosity
$\rho$	density
$t$	time
$x, r, \theta$	axial, radial and circumferential coordinate
$\eta$	radial coordinate after transformation
$\sigma_k, \sigma_\varepsilon, \kappa$	Constants of the k- $\varepsilon$ -model
$C_\mu, C_1, C_2$	Constants of the k- $\varepsilon$ -model
$\phi$	general variable standing for u, v, w, p, k or $\varepsilon$
$S_\phi$	general source term
$C_0$	seal clearance by centric shaft position
$\delta$	seal clearance by eccentric shaft position
$r_0$	radius of the precession motion of the shaft
$e = \frac{r_0}{c_0}$	perturbation parameter
$\omega$	rotational frequency of the shaft
$\Omega$	precession frequency of the shaft
$\xi$	entrance lost-coefficient
$L$	Length of the seal

$r_i$  radius of the rotor (shaft)  
 $r_a$  radius of the stator

Subscripts

0 zeroth order variables  
 1 first order variables  
 R rotor  
 S stator

MATHEMATICAL MODEL

To describe turbulent flow by the Navier-Stokes equations the velocities and the pressure are separated into mean and fluctuating quantities.

$$\begin{aligned} u &= \bar{u} + u' & v &= \bar{v} + v' \\ w &= \bar{w} + w' & p &= \bar{p} + p' \end{aligned}$$

Time-averaging of the Navier-Stokes equations leads to terms of the following form:  $\overline{u'v'}$ ,  $\overline{v'w'}$ ,  $\overline{u'w'}$ .

To substitute these terms one can use the Boussinesq's eddy-viscosity concept.

For example:

$$\overline{u'v'} = - \frac{\mu_t}{\rho} \left( \frac{\partial \bar{u}}{\partial y} + \frac{\partial \bar{v}}{\partial x} \right) \quad (2)$$

$\mu_t$  is the turbulent viscosity, which is not a fluid property but depends strongly on the state of flow. Summing up the laminar and turbulent viscosity to an effective viscosity

$$\mu_e = \mu_l + \mu_t, \quad (3)$$

one obtains the following time-averaged Navier-Stokes equations for turbulent flow. (In the following the overbars are omitted.)

1. axial momentum:

$$\begin{aligned} \rho \frac{\partial u}{\partial t} + \frac{\partial}{\partial x}(\rho u u) - \frac{\partial}{\partial x}(\mu_e \frac{\partial u}{\partial x}) + \frac{1}{r} \frac{\partial}{\partial r}(r \rho v u) - \frac{1}{r} \frac{\partial}{\partial r}(r \mu_e \frac{\partial u}{\partial r}) + \frac{1}{r} \frac{\partial}{\partial \theta}(\rho w u) - \frac{1}{r} \frac{\partial}{\partial \theta}(\mu_e \frac{\partial u}{\partial \theta}) = \\ - \frac{\partial p}{\partial x} + \frac{\partial}{\partial x}(\mu_e \frac{\partial u}{\partial x}) + \frac{1}{r} \frac{\partial}{\partial r}(r \mu_e \frac{\partial v}{\partial x}) + \frac{1}{r} \frac{\partial}{\partial \theta}(\mu_e \frac{\partial w}{\partial x}) \end{aligned} \quad (4)$$

## 2. radial momentum:

$$\begin{aligned} \rho \frac{\partial v}{\partial t} + \frac{\partial}{\partial x}(\rho uv) - \frac{\partial}{\partial x}(\mu_e \frac{\partial v}{\partial x}) + \frac{1}{r} \frac{\partial}{\partial r}(r \rho v v) - \frac{1}{r} \frac{\partial}{\partial r}(r \mu_e \frac{\partial v}{\partial r}) + \frac{1}{r} \frac{\partial}{\partial \theta}(\rho w v) - \frac{1}{r} \frac{\partial}{\partial \theta}(\frac{1}{r} \mu_e \frac{\partial v}{\partial \theta}) = \\ - \frac{\partial p}{\partial r} + \frac{1}{r} \frac{\partial}{\partial r}(r \mu_e \frac{\partial v}{\partial r}) + \frac{\partial}{\partial x}(\mu_e \frac{\partial u}{\partial r}) + \frac{1}{r} \frac{\partial}{\partial \theta}(r \mu_e \frac{\partial}{\partial r}(\frac{w}{r})) - \frac{2}{r^2} \mu_e \frac{\partial w}{\partial \theta} - \frac{2}{r^2} \mu_e v + \frac{\rho}{r} w^2 \end{aligned} \quad (5)$$

## 3. tangential momentum

$$\begin{aligned} \rho \frac{\partial w}{\partial t} + \frac{\partial}{\partial x}(\rho u w) - \frac{\partial}{\partial x}(\mu_e \frac{\partial w}{\partial x}) + \frac{1}{r} \frac{\partial}{\partial r}(r \rho v w) - \frac{1}{r} \frac{\partial}{\partial r}(r \mu_e \frac{\partial w}{\partial r}) + \frac{1}{r} \frac{\partial}{\partial \theta}(\rho w w) - \frac{1}{r} \frac{\partial}{\partial \theta}(\frac{1}{r} \mu_e \frac{\partial w}{\partial \theta}) = \\ - \frac{1}{r} \frac{\partial p}{\partial \theta} + \frac{1}{r} \frac{\partial}{\partial r}(\mu_e \frac{\partial v}{\partial \theta}) + \frac{\partial}{\partial x}(\frac{1}{r} \mu_e \frac{\partial u}{\partial \theta}) + \frac{1}{r^2} \mu_e \frac{\partial v}{\partial \theta} - \frac{w}{r^2} \frac{\partial}{\partial r}(r \mu_e) + \frac{1}{r} \frac{\partial}{\partial \theta}(\frac{2}{r} \mu_e v) + \frac{1}{r} \frac{\partial}{\partial \theta}(\frac{1}{r} \mu_e \frac{\partial w}{\partial \theta}) - \frac{\rho}{r} v w \end{aligned} \quad (6)$$

## 4. continuity equation

$$\frac{\partial}{\partial x}(\rho u) + \frac{1}{r} \frac{\partial}{\partial r}(r \rho v) + \frac{1}{r} \frac{\partial}{\partial \theta}(\rho w) = 0 \quad (7)$$

To describe  $\mu_t$  we use the k- $\epsilon$  turbulence model [3, 4]. This model determines  $\mu_t$  as a function of the kinetic energy k of the turbulent motion and the energy dissipation  $\epsilon$ . It is relative simple and often used to calculate the turbulent flow in seals [12, 13, 14, 15]. Stoff [12], for example, compares his flow measurements in a labyrinth seal with calculations on base of the k- $\epsilon$  model. He observes that both agree well.

$$\mu_t = c_\mu \rho \frac{k^2}{\epsilon} \quad (8)$$

The equations for k and  $\epsilon$  can be derived in exact form from the Navier-Stokes equations

## 5. turbulence energy k

$$\begin{aligned} \rho \frac{\partial k}{\partial t} + \frac{\partial}{\partial x}(\rho u k) - \frac{\partial}{\partial x}(\frac{\mu_e}{\sigma_k} \frac{\partial k}{\partial x}) + \frac{1}{r} \frac{\partial}{\partial r}(r \rho v k) - \frac{1}{r} \frac{\partial}{\partial r}(r \frac{\mu_e}{\sigma_k} \frac{\partial k}{\partial r}) + \frac{1}{r} \frac{\partial}{\partial \theta}(\rho w k) - \frac{1}{r} \frac{\partial}{\partial \theta}(\frac{1}{r} \frac{\mu_e}{\sigma_k} \frac{\partial k}{\partial \theta}) = \\ G - \rho \epsilon \end{aligned} \quad (9)$$

## 6. energy dissipation $\epsilon$

$$\rho \frac{\partial \epsilon}{\partial t} + \frac{\partial}{\partial x}(\rho u \epsilon) - \frac{\partial}{\partial x} \left( \frac{\mu_e \partial \epsilon}{\sigma_\epsilon \partial x} \right) + \frac{1}{r} \frac{\partial}{\partial r} (r \rho v \epsilon) - \frac{1}{r} \frac{\partial}{\partial r} \left( r \frac{\mu_e \partial \epsilon}{\sigma_\epsilon \partial r} \right) + \frac{1}{r} \frac{\partial}{\partial \theta} (\rho w \epsilon) - \frac{1}{r} \frac{\partial}{\partial \theta} \left( \frac{1}{r} \frac{\mu_e \partial \epsilon}{\sigma_\epsilon \partial \theta} \right) = C_1 \frac{\epsilon}{k} G - C_2 \rho \frac{\epsilon^2}{k} \quad (10)$$

$$G = \mu_e \left\{ 2 \left( \frac{\partial v}{\partial r} \right)^2 + \left( \frac{\partial u}{\partial x} \right)^2 + \left( \frac{1}{r} \frac{\partial w}{\partial \theta} + \frac{v}{r} \right)^2 + \left( \frac{\partial v}{\partial x} + \frac{\partial u}{\partial r} \right)^2 + \left( \frac{1}{r} \frac{\partial v}{\partial \theta} + \frac{\partial w}{\partial r} - \frac{w}{r} \right)^2 + \left( \frac{\partial w}{\partial x} + \frac{1}{r} \frac{\partial u}{\partial \theta} \right)^2 \right\}$$

$$C_\mu = 0.09 \quad C_1 = 1.44 \quad C_2 = 1.92 \quad (11)$$

$$\kappa = 0.4187 \quad \sigma_k = 1. \quad \sigma_\epsilon = \frac{\kappa}{C_\mu^5 (C_1 - C_2)}$$

To model the flow in the case of a shaft moving on an eccentric orbit, a coordinate-transformation [5, 6] is made. (Fig. 1)

$$\eta = r_a - \frac{r_a - r}{\delta} C_0 \quad (12)$$

$\delta(\theta, t)$  is the seal clearance, varying with angle  $\theta$  and time  $t$ . By this transformation the eccentric moving shaft is reduced to a shaft rotating in the centre of the seal.

We must note that the following relations of the transformation must be used.

$$\left( \frac{\partial \phi}{\partial \theta} \right)_r = \left( \frac{\partial \phi}{\partial \theta} \right)_\eta + \left( \frac{\partial \phi}{\partial \eta} \right)_\theta \left( \frac{\partial \eta}{\partial \theta} \right)_r$$

$$\left( \frac{\partial \phi}{\partial t} \right)_r = \left( \frac{\partial \phi}{\partial t} \right)_\eta + \left( \frac{\partial \phi}{\partial \eta} \right)_t \left( \frac{\partial \eta}{\partial t} \right)_r \quad (13)$$

$$\left( \frac{\partial \phi}{\partial x} \right)_r = \left( \frac{\partial \phi}{\partial x} \right)_\eta$$

## PERTURBATION ANALYSIS

The rotordynamic coefficients of a seal are in a wide range independent of the shaft eccentricity. Therefore we can assume small shaft motions around the centered position which allow us to use a perturbation analysis.

$$\delta = C_0 - eh_1$$

$$u = u_0 + eu_1 \quad v = v_0 + ev_1$$

$$w = w_0 + ew_1 \quad p = p_0 + ep_1$$

With these expressions and the coordinate-transformation equation (12) the equations (4), (5), (6), (7), (9), (10) change themselves.

This is demonstrated in the following examples.

From equation (12) we obtain:

$$r = \eta + e \frac{h_1}{C_0} (r_a - \eta) \quad (14)$$

$$\frac{\partial}{\partial r} = \frac{C_0}{\delta} \frac{\partial}{\partial \eta} = \frac{1}{1 - e \frac{h_1}{C_0}} \frac{\partial}{\partial \eta} \quad (15)$$

and so:

$$\begin{aligned} \frac{1}{r} \frac{\partial}{\partial \theta} (r \rho v u) &= \frac{1}{\eta + e \frac{h_1}{C_0} (r_a - \eta)} \frac{1}{1 - e \frac{h_1}{C_0}} \frac{\partial}{\partial \eta} \{ \rho (\eta + e \frac{h_1}{C_0} (r_a - \eta)) (v_0 + ev_1) (u_0 + eu_1) \} \\ &= \frac{1}{\eta} \frac{\partial}{\partial \eta} (\eta \rho v_0 u_0) + e \frac{1}{\eta} \frac{\partial}{\partial \eta} \{ \eta \rho (u_0 v_1 + v_0 u_1) \} + e \frac{h_1}{C_0} \left\{ \frac{\partial}{\partial \eta} (\rho u_0 v_0) + \left(1 - \frac{r_a}{\eta}\right) \frac{1}{\eta} \rho u_0 v_0 \right\} \end{aligned} \quad (16)$$

$$\begin{aligned}
\frac{1}{r} \frac{\partial}{\partial \theta} (\rho u w) &= \frac{1}{\eta + e \frac{h_1}{C_0} (r_a - \eta)} \left\{ \frac{\partial}{\partial \theta} (\rho (u_0 + e u_1) (w_0 + e w_1)) \right. \\
&+ \left. \frac{\partial}{\partial \theta} (\rho (u_0 + e u_1) (w_0 + e w_1)) \frac{\partial}{\partial \theta} \left( r_a - \frac{r_a - r}{\delta} C_0 \right) \right\} \\
&= e \frac{1}{\eta} \frac{\partial}{\partial \theta} (\rho u_0 w_1 + \rho w_0 u_1) + e (\eta - r_a) \frac{1}{\eta} \frac{\partial}{\partial \theta} (\rho u_0 w_0) \frac{1}{C_0} \frac{\partial h_1}{\partial \eta}
\end{aligned} \tag{17}$$

$$\begin{aligned}
\rho \frac{\partial u}{\partial t} &= \rho \left( \frac{\partial u_0}{\partial t} + \frac{\partial u_1}{\partial t} \right) + \rho \frac{\partial (u_0 + e u_1)}{\partial \eta} \frac{\partial}{\partial t} \left( r_a - \frac{r_a - r}{\delta} C_0 \right) \\
&= e \rho \frac{\partial u_1}{\partial t} + e \rho \frac{\partial u_0}{\partial \eta} \left( \frac{\eta - r_a}{C_0} \right) \frac{\partial h_1}{\partial t}
\end{aligned} \tag{18}$$

One obtains a set of zero-order equations for  $u_0, v_0, w_0, p_0, k_0, \epsilon_0$  and a set of first-order equations for  $u_1, v_1, w_1, p_1$ . It is assumed that the viscosity  $\mu_e$  remains constant for small motions. Therefore the  $k_1$  and  $\epsilon_1$  equations can be dropped.

The variation of the seal clearance for an eccentric shaft can be described by the following equation

$$h_1 = \frac{z}{e} \cos \theta + \frac{y}{e} \sin \theta$$

So we establish the same assumptions as in [1], that the velocities and the pressure in circumferential direction can be described by sin- and cos-functions, in our first order equations

$$\begin{aligned}
u_1 &= u_{1c} \cos \theta + u_{1s} \sin \theta & v_1 &= v_{1c} \cos \theta + v_{1s} \sin \theta \\
w_1 &= w_{1c} \cos \theta + w_{1s} \sin \theta & p_1 &= p_{1c} \cos \theta + p_{1s} \sin \theta
\end{aligned}$$

By separating in the resulting equations the terms with  $\sin \theta$  and  $\cos \theta$  we obtain two real equations of every 1. order equation. These equations are then arranged in a new form by introducing complex variables.

$$\begin{aligned}\bar{u}_1 &= u_{1c} + iu_{1s} & \bar{v}_1 &= v_{1c} + iv_{1s} \\ \bar{w}_1 &= w_{1c} + iw_{1s} & \bar{p}_1 &= p_{1c} + ip_{1s} \\ \bar{h}_1 &= z + iy\end{aligned}$$

We now assume that the shaft is moving on a circular orbit with frequency  $\Omega$  around the centered position. Also  $\bar{h}_1$  takes the form:

$$\bar{h}_1 = r_0 e^{i\Omega t}$$

and similiary

$$\begin{aligned}\bar{u}_1 &= \hat{u}_1 e^{i\Omega t} & \bar{v}_1 &= \hat{v}_1 e^{i\Omega t} \\ \bar{w}_1 &= \hat{w}_1 e^{i\Omega t} & \bar{p}_1 &= \hat{p}_1 e^{i\Omega t}\end{aligned}$$

In the following we assume that  $t = 0$ ; this means that the shaft is just moving through the  $z$ -axis in the  $y$ -direction.

The resulting equations for  $u_0$ ,  $v_0$ ,  $w_0$ ,  $p_0$ ,  $k_0$ ,  $\epsilon_0$  and  $\hat{u}_1$ ,  $\hat{v}_1$ ,  $\hat{w}_1$  have all the same form.

$$\frac{\partial}{\partial x} (\rho u_0 \phi) - \frac{\partial}{\partial x} (\Gamma_\phi \frac{\partial \phi}{\partial x}) + \frac{1}{\eta} \frac{\partial}{\partial \eta} (\eta \rho v_0 \phi) - \frac{1}{\eta} \frac{\partial}{\partial \eta} (\Gamma_\phi \eta \frac{\partial \phi}{\partial \eta}) = S_\phi \quad (19)$$

### Zeroth Order Equations

$\phi$	$\Gamma_\phi$	$S_\phi$
$u_0$	$\mu_e$	$-\frac{\partial p_0}{\partial x} + \frac{\partial}{\partial x} (\mu_e \frac{\partial u_0}{\partial x}) + \frac{1}{\eta} \frac{\partial}{\partial \eta} (\mu_e \eta \frac{\partial v_0}{\partial x})$
$v_0$	$\mu_e$	$-\frac{\partial p_0}{\partial \eta} + \frac{\partial}{\partial x} (\mu_e \frac{\partial u_0}{\partial \eta}) + \frac{1}{\eta} \frac{\partial}{\partial \eta} (\mu_e \eta \frac{\partial v_0}{\partial \eta}) - \frac{2}{\eta^2} \mu_e v_0 + \frac{\rho}{\eta} w_0^2$
$w_0$	$\mu_e$	$-\frac{w_0}{\eta^2} \frac{\partial}{\partial \eta} (\eta \mu_e) - \frac{\rho}{\eta} v_0 w_0$
1	0	0
$k_0$	$\frac{\mu_e}{\sigma_k}$	$G - \rho \epsilon$
$\epsilon_0$	$\frac{\mu_e}{\sigma_\epsilon}$	$C_1 \frac{\epsilon}{k} G - C_2 \rho \frac{\epsilon^2}{k}$



First Order Equations

$\phi$	$\Gamma_\phi$	$S_\phi$
$\hat{u}_1$	$\mu_e$	$-\frac{\partial \hat{p}_1}{\partial x} + \frac{\partial}{\partial x}(\mu_e \frac{\partial \hat{u}_1}{\partial x}) + \frac{1}{\eta} \frac{\partial}{\partial \eta}(\eta \mu_e \frac{\partial \hat{v}_1}{\partial x}) - \frac{\partial}{\partial x}(\rho u_o \hat{u}_1) - \frac{1}{\eta} \frac{\partial}{\partial \eta}(\eta \rho u_o \hat{v}_1)$ $-\frac{\mu_e}{\eta^2} \hat{u}_1 + i\rho(-\Omega + \frac{w_o}{\eta}) \hat{u}_1 + i \frac{\rho}{\eta} u_o \hat{w}_1 - i \frac{\mu_e}{\eta} \frac{\partial \hat{w}_1}{\partial x} + D_1 + iD_2$
$\hat{v}_1$	$\mu_e$	$-\frac{\partial \hat{p}_1}{\partial \eta} + \frac{\partial}{\partial x}(\mu_e \frac{\partial \hat{u}_1}{\partial x}) + \frac{1}{\eta} \frac{\partial}{\partial \eta}(\eta \mu_e \frac{\partial \hat{v}_1}{\partial x}) - \frac{\partial}{\partial x}(\rho v_o \hat{u}_1) - \frac{1}{\eta} \frac{\partial}{\partial \eta}(\eta \rho v_o \hat{v}_1)$ $-i \mu_e \frac{\partial}{\partial \eta}(\frac{\hat{w}_1}{\eta}) - 3 \frac{\mu_e}{\eta^2} \hat{v}_1 + i\rho(\frac{w_o}{\eta} - \Omega) \hat{v}_1 + (2 \frac{\rho}{\eta} w_o + i 2 \frac{\mu_e}{\eta^2} + i \frac{\rho}{\eta} v_o) \hat{w}_1 + D_3 + iD_4$
$\hat{w}_1$	$\mu_e$	$i \frac{\hat{p}_1}{\eta} - i \frac{\partial}{\partial x}(\frac{\mu_e}{\eta} \hat{u}_1) - i \frac{1}{\eta} \frac{\partial}{\partial \eta}(\mu_e \hat{v}_1) - \frac{\partial}{\partial x}(\rho w_o \hat{u}_1) - \frac{1}{\eta^2} \frac{\partial}{\partial \eta}(\rho \eta^2 w_o \hat{v}_1)$ $- 2 \frac{\mu_e}{\eta^2} \hat{w}_1 - i 3 \frac{\mu_e}{\eta^2} \hat{v}_1 - (\frac{\rho}{\eta} v_o + i\rho\Omega + \frac{1}{\eta^2} \frac{\partial \eta \mu_e}{\partial \eta} - i 2 \frac{\rho}{\eta} w_o) \hat{w}_1 + D_5 + iD_6$

Only the first order continuity-equation to determine  $\hat{p}_1$  shows a slightly modified form.

$$\frac{\partial}{\partial x}(\rho \hat{u}_1) + \frac{1}{\eta} \frac{\partial}{\partial \eta}(\eta \rho \hat{v}_1) = i \frac{\rho}{\eta} \hat{w}_1 + D_7 + iD_8 \quad (20)$$

The parameters  $D_1 - D_8$  do not depend on  $\hat{u}_1, \hat{v}_1, \hat{w}_1, \hat{p}_1$  and result from the coordinate-transformation. ( $D_1 - D_8$  are shown in the appendix.)

FINITE-DIFFERENCE METHOD

For solving these equations a finite-difference procedure is used which is based on a method published by Gosman and Pun [7]. The seal is discretized by a grid (Fig. 2) and the variables are calculated at the nodes. The velocities  $u, v$  are determined at points which lie between the nodes where the vari-

ables  $p, w, k, \varepsilon$  are calculated (Fig. 3). Because of its general convergence a 'hybrid - difference' method is used, which means that the convective terms are calculated by a 'upwind'- or a 'central-difference' method as a function of flow-velocity and grid-distance.

Because there is no explicit equation to calculate  $p$  we use the continuity equation. Starting by a guess for  $p$ , the momentum-equations are solved; with the resulting values  $u, v$  ( $\hat{u}_1, \hat{v}_1, \hat{w}_1$ ) the flow through the control-area around a point for the pressure  $p$  ( $\hat{p}_1$ ) is calculated. If the difference between the entrance- and the exit-flow rate is less than 0,  $p$  must be reduced; in the opposite case  $p$  must be increased. This is done by the 'SIMPLE'-procedure [8] or better by the more modern version 'PISO' [9].

However one has to respect in the determination of  $\hat{p}_1$  with these procedures that the equation for  $\hat{w}_1$  has not the same form as for  $\hat{u}_1$  and  $\hat{v}_1$ . Also we have to notice that  $u_0, v_0, p_0, w_0, k_0, \varepsilon_0$  are real-, while  $\hat{u}_1, \hat{v}_1, \hat{w}_1, \hat{p}_1$  are of complex type. The mesh to calculate  $u, v$  doesn't extend all the way to the boundary wall, and the component  $u, w$  is allowed to slip in accordance with the logarithmic law of the wall.

## LEAKAGE FLOW AND DYNAMIC COEFFICIENTS

### Leakage flow, Centered Position

For centered shaft position the values  $u_0, v_0, p_0, w_0, k_0, \varepsilon_0$  are determined.

Boundary conditions:

$$\begin{array}{lll} u_{oS} = 0 & v_{oS} = 0 & w_{oS} = 0 \\ u_{oR} = 0 & v_{oR} = 0 & w_{oR} = \omega \cdot r_i \end{array}$$

The leakage results from the calculated axial velocity  $u_0$ .

### Dynamic Coefficients, Eccentric Shaft Motion

For calculating the dynamic coefficients the following assumptions are made:

1. The shaft rotates on a circular orbit around the centered position.
2. At time  $t = 0$  the shaft is located at:  $z = r_0, y = 0$
3. The viscosity  $\mu_e$  remains constant in spite of the eccentric motion.

Boundary conditions: (Fig. 4, 5)

$$\text{Stator: } \hat{u}_{1S} = (0., 0.) \quad \hat{v}_{1S} = (0., 0.) \quad \hat{w}_{1S} = (0., 0.)$$

$$\text{Rotor: } \hat{u}_{1R} = (0., 0.) \quad \hat{v}_{1R} = (0., (\Omega - \omega) \cdot C_0) \quad \hat{w}_{1R} = (\Omega C_0, 0.)$$

$$\text{Entrance: } p_A = \frac{1}{2} \rho u^2 (1 + \xi) + p_B$$

$$\hat{p}_{1Bj} = -\rho u_{0Bj} (1 + \xi) \hat{u}_{1Bj}$$

$$\text{Exit: } \hat{p}_{1Cj} = (0., 0.)$$

To satisfy the entrance condition we make use of the iterative character of the finite-difference method. This means that we start with a pressure  $\hat{p}_{1Bj}$  at the entrance and after every iteration step we check if the calculated  $\hat{u}_{1Bj}$  satisfy condition (21). If not, the pressure  $\hat{p}_{1Bj}$  will be corrected.

The resulting forces on the shaft are calculated by a pressure integration for the five precession frequencies:  $\Omega = 0\omega, 0,5 \omega, 1,0 \omega, 1,5 \omega, 2 \omega$ .

$$- F_z = \frac{\pi r_i}{C_0} \int_L p_{1C} dx \quad (22)$$

$$- F_y = \frac{\pi r_i}{C_0} \int_L p_{1S} dx \quad (23)$$

By a 'Least-Square-Fit' we obtain the rotor-dynamic coefficients of (1) from the following equations

$$- F_z = K + C\Omega - M\Omega^2$$

$$- F_y = -k + C\Omega + m\Omega^2 \quad (24)$$

The precession frequencies can be arbitrarily chosen, because the dynamic coefficients are mostly independent of them. We take the same as in [1].

#### RESULTS FOR AN ANNULAR SEAL

To test the theory, calculations are made for a straight smooth seal. The results are compared with the experimental values of Massmann [10] and the results of Childs theory [1].

Seal Data:

$$\begin{array}{ll} L = 23,5 \text{ mm} & \mu_1 = 0,7 \cdot 10^{-3} \text{ Ns/m}^3 \\ r_i = 23,5 \text{ mm} & \rho = 996 \text{ kg/m}^3 \\ C_o = 0,2 \text{ mm} & \xi = 0,5 \end{array}$$

A fully developed turbulent axial and circumferential flow at the entrance of the seal is assumed. As in [10] flowrates are measured, in the presented calculation we suppose that the axial flow velocity is known:

$$u_{\text{average}} = 16,46 \text{ m/s}$$

and that the average circumferential velocity at the entrance is half the shaft-speed.

For a known mass flow the pressure difference between entrance and exit of the seal can be calculated. The results of this theory are compared with Childs theory in Fig. 6.

In Fig. 7, 8, 9, 10, 11 results of the presented theory, Childs theory [1] and experimental data from Massmann [10] are shown.

Both theories are in good agreement with each other and with the measurements. For calculation a mesh with 15 x 5 nodes in x-r direction was applied. The CPU time was about 30 sec on a Siemens 7.561 computer.

#### RESULTS FOR A GROOVED SEAL

We also made some calculations, for the grooved seal, whose geometry and seal data are shown in Fig. 12. In Fig. 13 the leakage for a given pressure difference is presented as a function of the groove depth. First the leakage decreases and then slightly increases again. This behaviour agrees with the measurements of Black [11].

In Fig. 14, 15, 16, 17 the stiffness  $K$ ,  $k$  and the damping  $D$ ,  $d$  are shown. The coefficients  $K$ ,  $k$ ,  $D$  decrease with growing groove depth. Only the damping  $d$  increases. Although we haven't yet any experimental results for this seal the tendencies seem to be right.

#### CONCLUSION

It is shown that it is possible to calculate the dynamic coefficients of seals with a finite-difference method, based on the Navier-Stokes equation in connection with a turbulence model. Although application on straight seals is possible,

it was not our aim to develop a procedure for this seal configuration but to present a method which will be applicable on grooved seals. The superiority of the theory versus other methods is the simplicity in use for grooved seals by only neglecting the terms  $D_1 - D_8$  in the equations for  $\hat{u}_1, \hat{v}_1, \hat{w}_1, \hat{p}_1$  in the grooves, while there exists no mesh displacement.

Appendix:

Transformation-constants for first order equations

$$D_1 = \frac{\partial}{\partial \eta} \left( \mu_e \frac{\partial v_o}{\partial x} + \mu_e \frac{\partial u_o}{\partial \eta} - \rho v_o u_o \right) + \left( 1 - \frac{r_a}{\eta} \right) \frac{1}{\eta} \left( \mu_e \frac{\partial v_o}{\partial x} - \rho v_o u_o \right) + \left( 1 - \frac{r_a}{\eta} \right) \frac{\mu_e}{\eta} \frac{\partial u_o}{\partial \eta}$$

$$D_2 = \left( \frac{r_a}{\eta} - 1 \right) \left\{ \frac{\partial}{\partial \eta} \left( \mu_e \frac{\partial w_o}{\partial x} \right) - \frac{\partial}{\partial \eta} (\rho u_o w_o) \right\} - \Omega \rho \frac{\partial u_o}{\partial \eta} (\eta - r_a)$$

$$D_3 = \left( 1 - \frac{r_a}{\eta} \right) \left( \frac{\rho}{\eta} w_o w_o - \frac{\rho}{\eta} v_o v_o - 2 \frac{\mu_e}{\eta^2} v_o + 2 \frac{\mu_e}{\eta} \frac{\partial v_o}{\partial \eta} \right) - \frac{\partial}{\partial \eta} (\rho v_o v_o) - \frac{\partial p_o}{\partial \eta} + 2 \frac{\partial}{\partial \eta} \left( \mu_e \frac{\partial v_o}{\partial \eta} \right)$$

$$D_4 = \left( \frac{r_a}{\eta} - 1 \right) \left\{ \frac{\partial}{\partial \eta} \left( \mu_e \eta \frac{\partial}{\partial \eta} \left( \frac{w_o}{\eta} \right) \right) - \frac{\partial}{\partial \eta} (\rho w_o v_o) \right\} - \Omega \rho \frac{\partial v_o}{\partial \eta} (\eta - r_a)$$

$$D_5 = \frac{1}{\eta} \frac{\partial}{\partial \eta} \left( \mu_e \eta \frac{\partial w_o}{\partial \eta} \right) - \frac{1}{\eta} \frac{\partial}{\partial \eta} (\mu_e w_o) + \left( 1 - 2 \frac{r_a}{\eta} \right) \mu_e \frac{\partial}{\partial \eta} \left( \frac{w_o}{\eta} \right) - \frac{\partial}{\partial \eta} (\rho v_o w_o) + 2 \frac{\rho}{\eta} v_o w_o \left( \frac{r_a}{\eta} - 1 \right)$$

$$D_6 = \left( 1 - \frac{r_a}{\eta} \right) \left\{ \frac{\partial}{\partial \eta} (\rho w_o w_o) - \frac{\partial}{\partial \eta} \left( 2 \frac{\mu_e}{\eta} v_o \right) + \frac{\partial p_o}{\partial \eta} \right\} - \Omega \rho \frac{\partial w_o}{\partial \eta} (\eta - r_a)$$

$$D_7 = \frac{\rho}{\eta} v_o \left( \frac{r_a}{\eta} - 1 \right) - \rho \frac{\partial v_o}{\partial \eta}$$

$$D_8 = \left( 1 - \frac{r_a}{\eta} \right) \rho \frac{\partial w_o}{\partial \eta}$$

With, for example:

$$\frac{1}{r} \frac{\partial}{\partial r} (r \mu_e \frac{\partial u}{\partial r}) + \frac{1}{r} \frac{\partial}{\partial r} (r \mu_e \frac{\partial v}{\partial x}) = \frac{1}{r} \frac{\partial}{\partial r} (r \tau_{xr}) \implies \frac{1}{\eta} \frac{\partial}{\partial \eta} (\eta \tau_{xr_o}) + e \frac{1}{\eta} \frac{\partial}{\partial \eta} (\eta \tau_{xr_1}) + \frac{h_1}{c_o} \left\{ \frac{1}{\eta} \frac{\partial}{\partial \eta} \left( \eta \left( \frac{r_a}{\eta} - 1 \right) \tau_{xr_o} \right) + \left( 2 - \frac{r_a}{\eta} \right) \frac{1}{\eta} \frac{\partial}{\partial \eta} (\eta \tau_{xr_o}) \right\}$$

## References

- /1/ Childs, D.W.: Finite Length solutions for rotordynamic coefficients of turbulent annular seals. Journal of Lubrication Technology, ASME-Paper, No 82 Lub. 42, 1982.
- /2/ Atkins, K.E.; Tison, J.D. and Wacht, J.C.: Critical speed analysis of an eight-stage centrifugal pump. Proceedings of the second international pump symposium.
- /3/ Launder, B.E.; Spalding, D.B.: The numerical computation of turbulent flows. Computer methods in applied mechanics and engineering. 3 (1974) 269 - 289.
- /4/ Rodi, W.: Turbulence models and their application in hydraulics. Presented by the IAHR-Section on Fundamentals of Division II. Experimental and mathematical Fluid Dynamics.
- /5/ Yao, L.S.: Analysis of heat transfer in slightly eccentric annuli. ASME Journal of Heat Transfer May 1980 Vol. 102 p 279 - 284.
- /6/ Ockendon, J.R.; Hodgkins, W.R.: Moving boundary problems in heat flow and diffusion. Being the proceedings of the conference held at the university of Oxford 25-27 March 1974.
- /7/ Gosman, A.D.; Pun, W.: Lecture notes for course entitled: 'Calculation of recirculating flows'. Imperial College London, Mech. Eng. Dept., HTS/74/2.
- /8/ Patankar, S.V.: Numerical heat transfer and fluid flow. Mc Graw Hill Book Company (1980).
- /9/ Benodekar, R.W.; Goddard, A.J.H.; Gosman, A.D.; ISSU R.I.: Numerical prediction of turbulent flow over surfacemounted ribs. AIAA Journal Vol. 23, No 3, March 1985.
- /10/ Massmann, H.: Ermittlung der dynamischen Parameter axial turbulent durchströmter Ringspalte bei inkompressiblen Medien. Dissertation, Universität Kaiserslautern, 1986.
- /11/ Black, H.F.; Cochrane, E.A.: Leakage and hybrid bearing properties of serrated seals in centrifugal pumps. 6th International Conference on Fluid Sealing, February 27th - March 2nd, 1973. Munich, German Federal Republic.
- /12/ Stoff, H.: Calcul et mesure de La turbulence d'un écoulement incompressible dans le Labyrinthe entre un arbre en rotation et un cylindre stationnaire. Thesis No. 342 (1949) Swiss Federal College of Technology, Lausanne, Juris Verlag Zürich, 1979.
- /13/ Wyssmann, H.R.; Pham, T.C.; Jenny, R.J.: Prediction of stiffness and damping coefficients for centrifugal compressor labyrinth seals. ASME Journal of Engineering for Gas Turbines and Power, Vol. 106, Oct. 1984.

- /14/ Rhode, D.L.; Demko, J.A.; Traegner, U.K.; Morrison, G.L.; Sobolik, S.R.: Prediction of incompressible flow in labyrinth seals. ASME Journal of Fluids Engineering, Vol. 108, March 1986.
- /15/ Wittig, S.; Jackobsen, K.; Schelling, U.; Dörr, L.; Kim, S.: Wärmeübergangszahlen in Labyrinthdichtungen. VDI-Verichte 572.1, Thermische Strömungsmaschinen '85, p. 337 - 356.

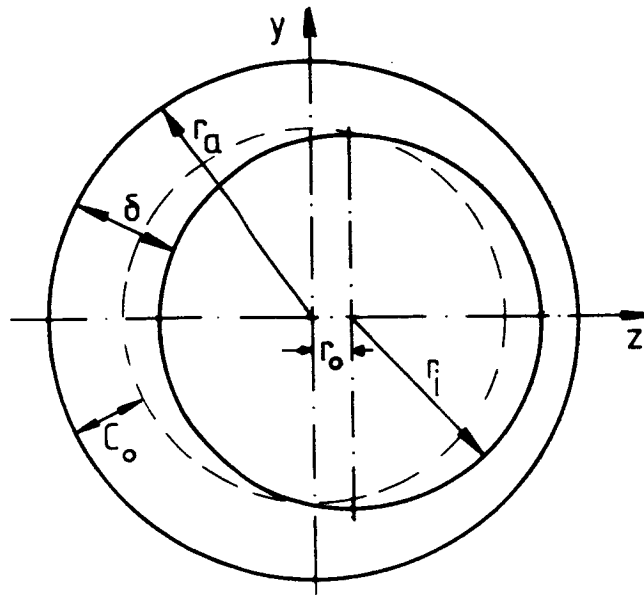

Fig. 1 Geometry of the eccentric shaft

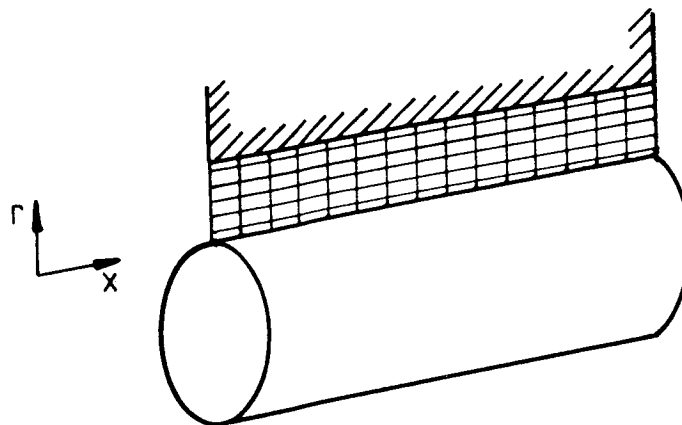

Fig. 2 Mesh arrangement in the seal

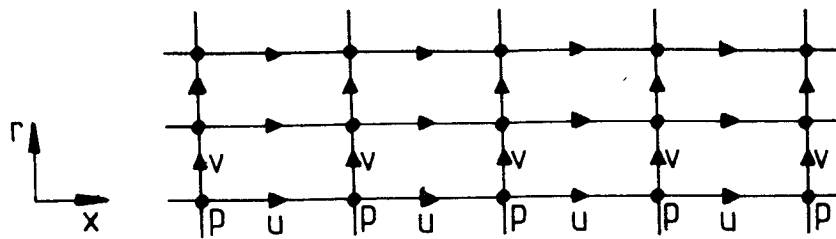

Fig. 3 Velocities and pressure in a staggered grid

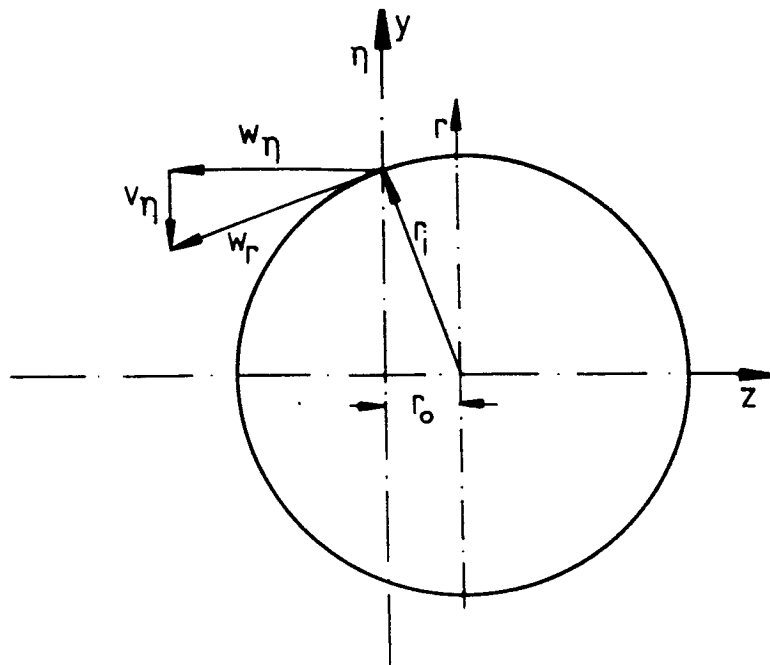

Fig. 4 Change of the velocities due to the coordinate transformation

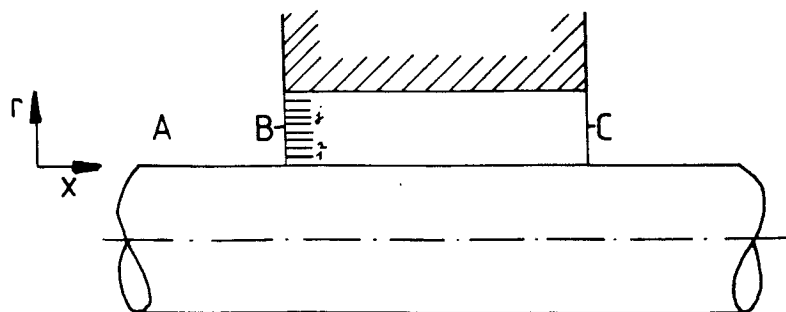

Fig. 5 Locations where the boundary-conditions must be specified



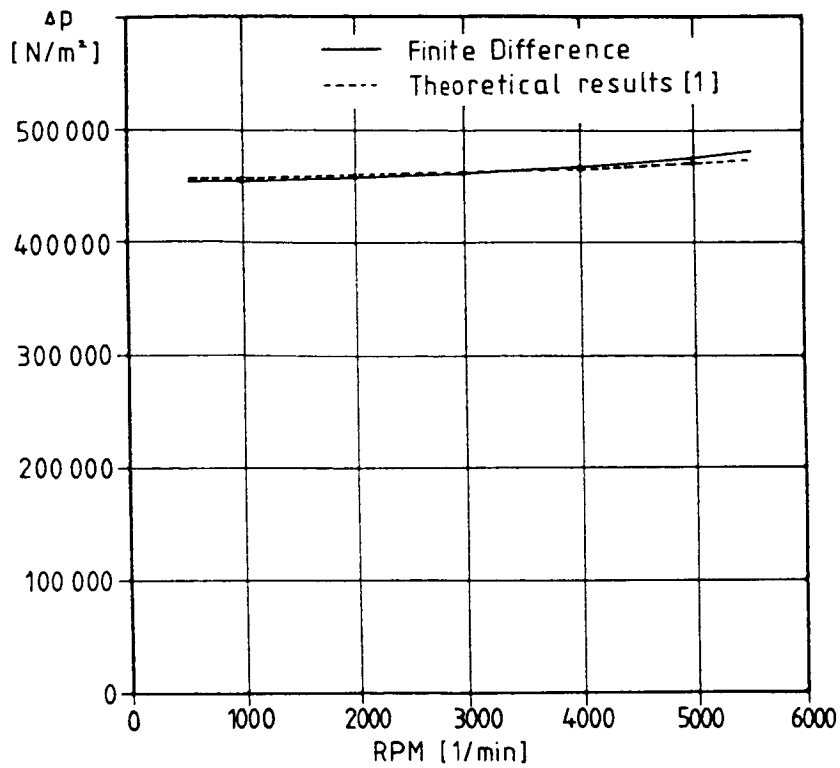

Fig. 6 Pressure difference as a function of the shaft speed for an annular seal

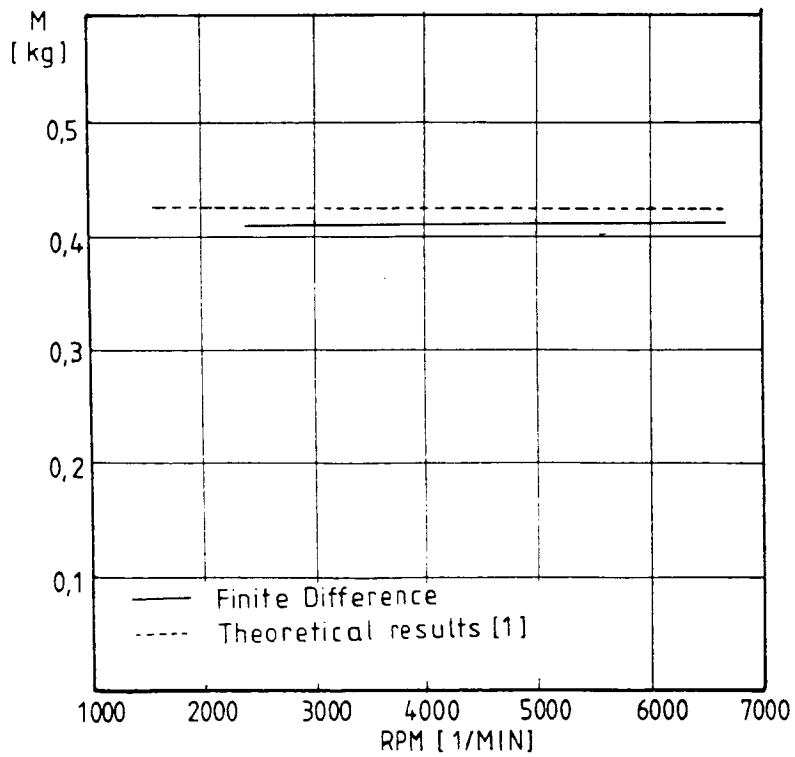

Fig. 7 Direct-inertia as a function of the shaft speed for an annular seal

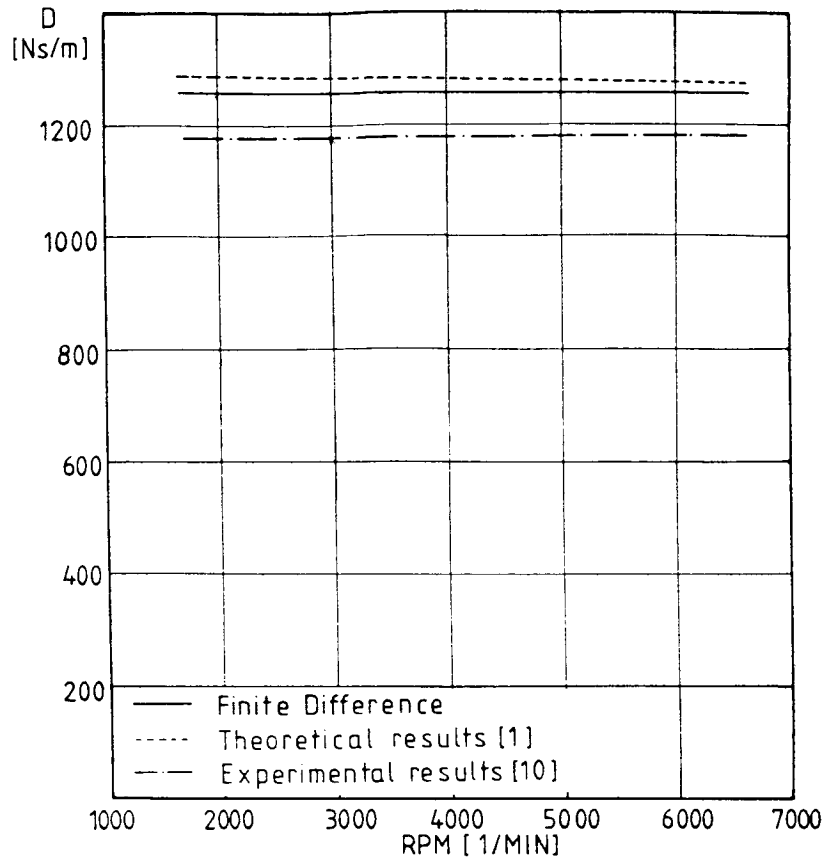

Fig. 8 Direct damping as a function of the shaft speed for an annular seal

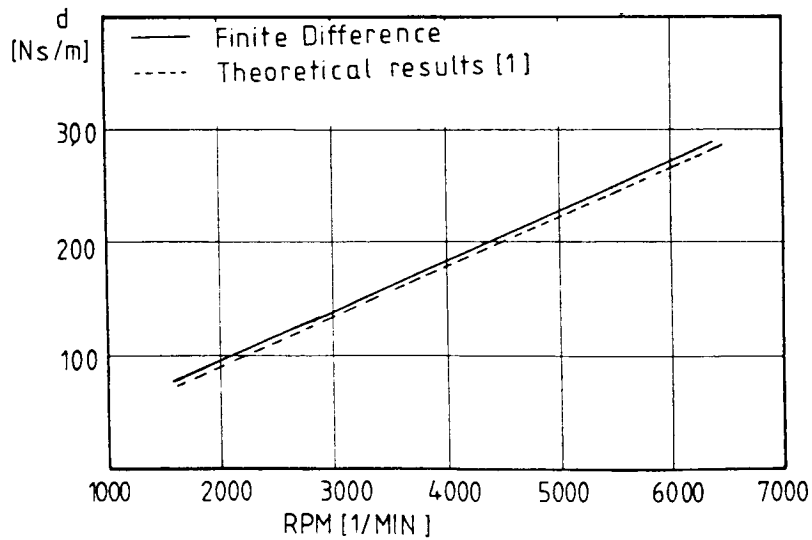

Fig. 9 Cross-coupling damping as a function of the shaft speed for an annular seal

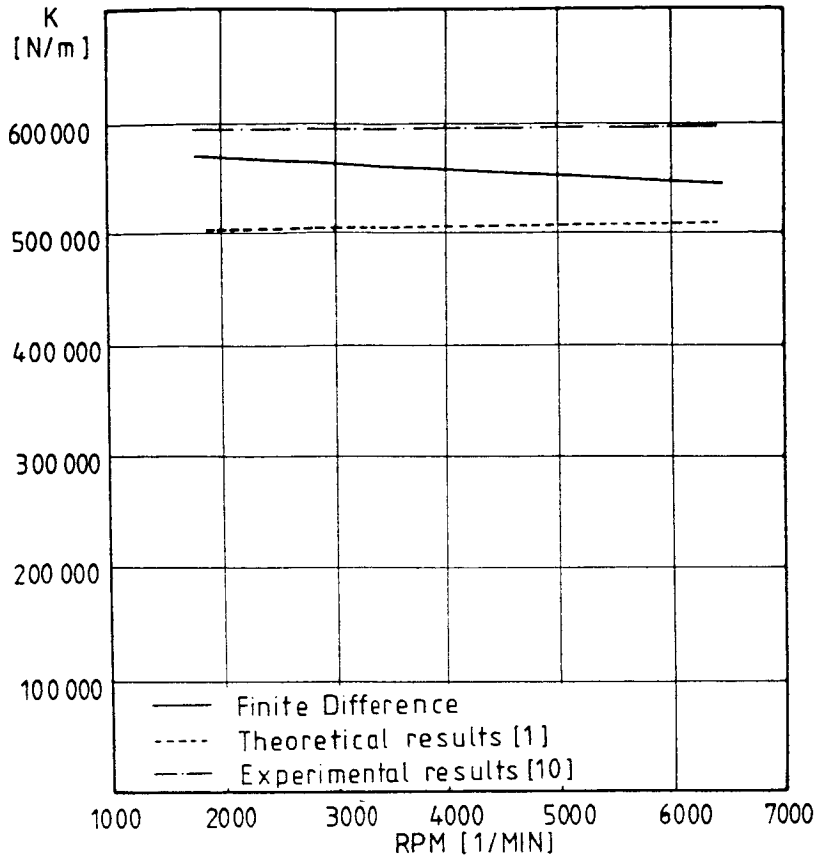

Fig. 10 Direct stiffness as a function of the shaft speed for an annular seal

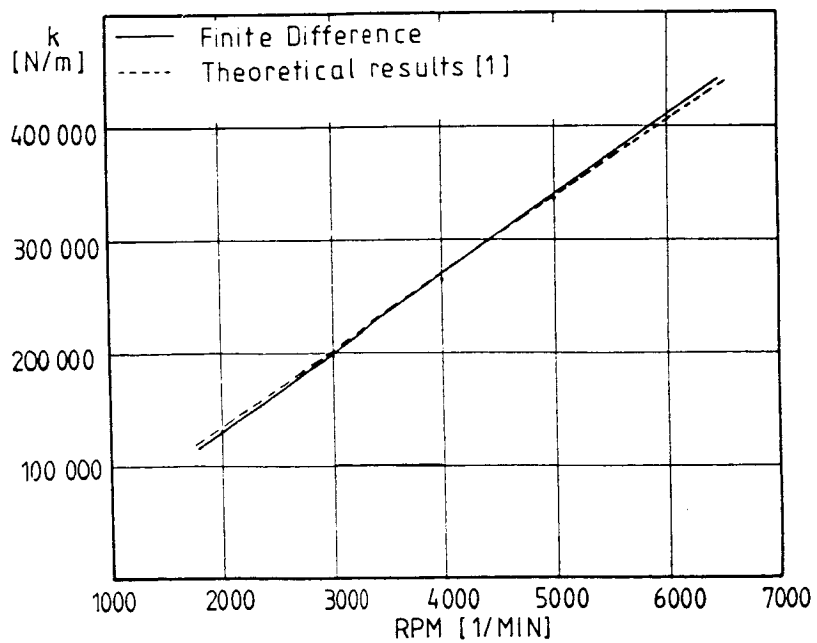

Fig. 11 Cross-coupling stiffness as a function of the shaft speed for an annular seal

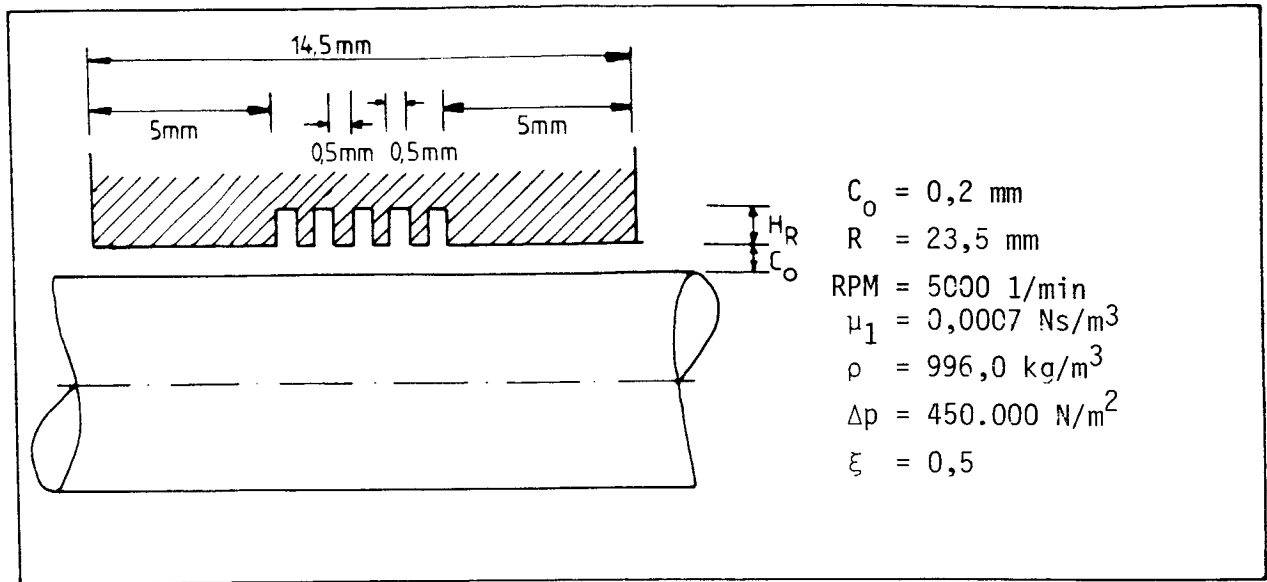

Fig. 12 Geometry of the grooved seal

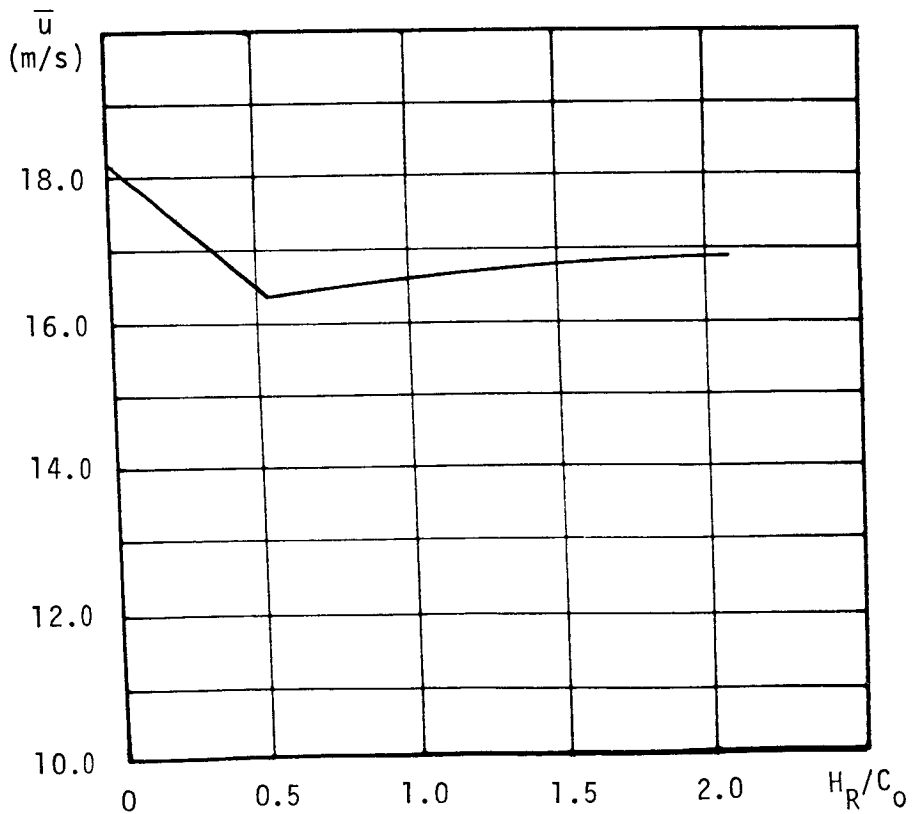

Fig. 13 Leakage of grooved seals for a given pressure as a function of the groove depth

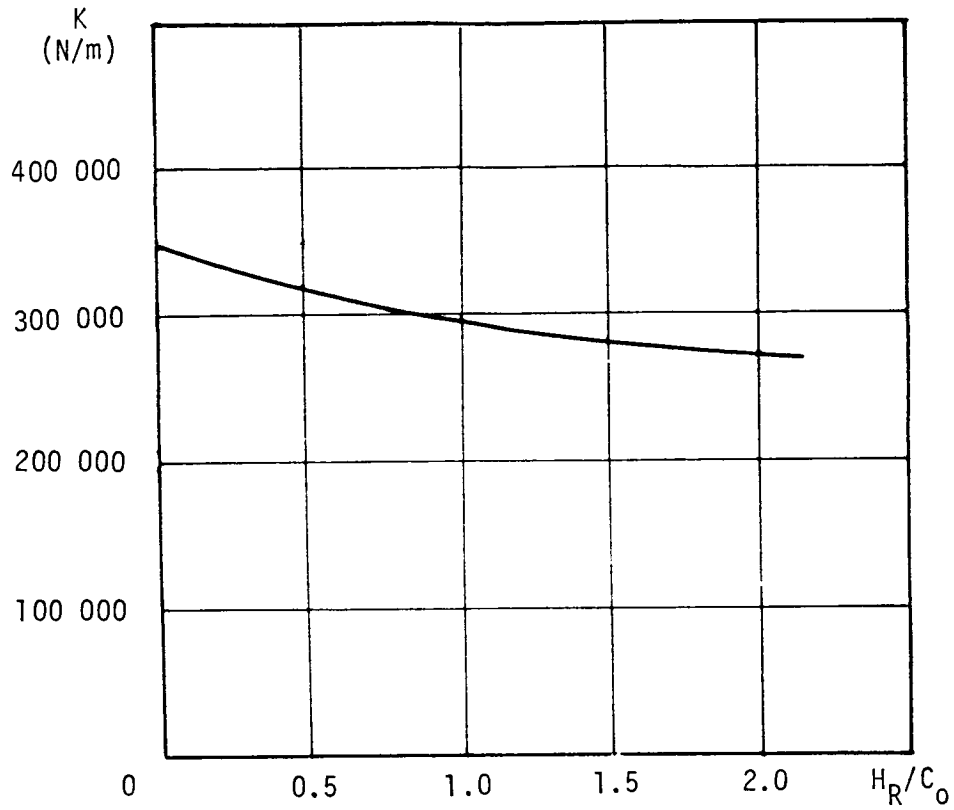

Fig. 14 Direct stiffness of grooved seals as a Function of the groove depth

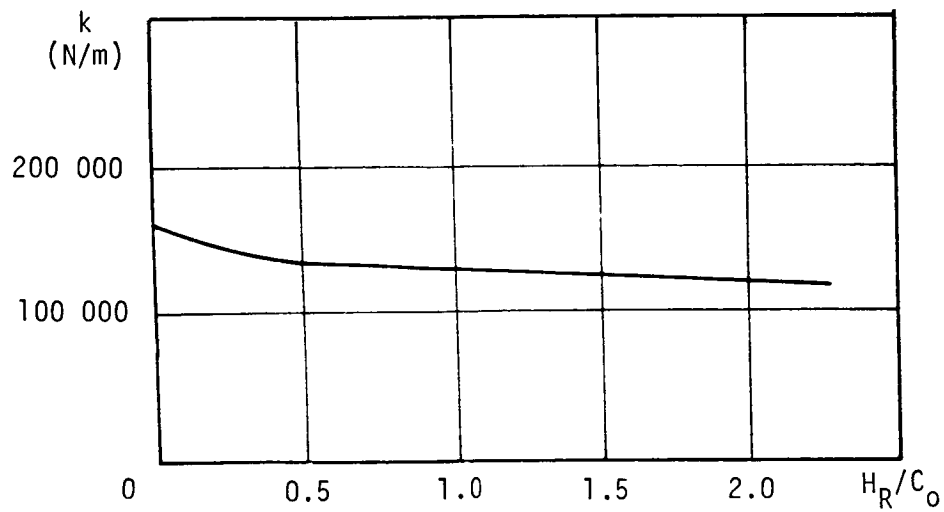

Fig. 15 Cross-coupling stiffness of grooved seals as a function of the groove depth

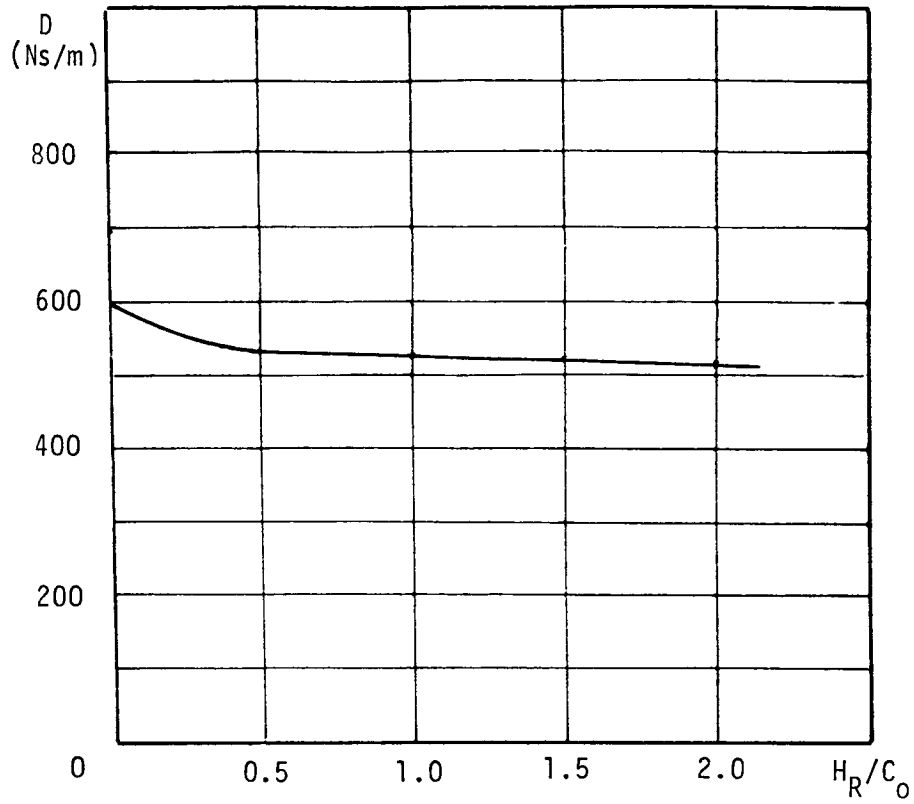

Fig. 16 Direct damping of grooved seals as a function of the groove depth

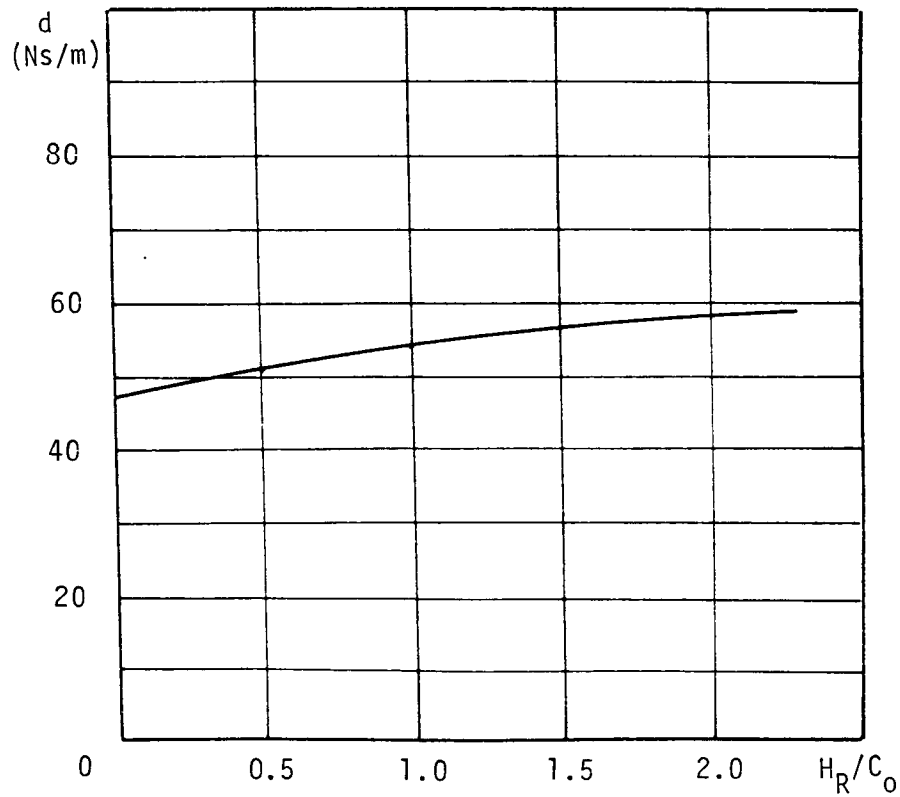

Fig 17 Cross-coupling damping of grooved seals as a function of the groove depth