

N87 - 22749

Experimental Characterization of Deployable Trusses and Joints

By

**Dr. R. Ikegami Mr. S. M. Church
Boeing Aerospace Company
Seattle, WA.**

**Dr. D. A. Keinholz Mr. B. L. Fowler
CSA Engineering, Inc.
Palo Alto, CA.**

**Presented at
Workshop On Structural Dynamics and Control Interaction of Flexible Structures
Marshall Space Flight Center
Huntsville, Alabama
April 22-24, 1986**

ABSTRACT

The structural dynamic properties of trusses are strongly affected by the characteristics of joints connecting the individual beam elements. Joints are particularly significant in that they are often the source of nonlinearities and energy dissipation. While the joints themselves may be physically simple, direct measurement is often necessary to obtain a mathematical description suitable for inclusion in a system model. Force state mapping is a flexible, practical test method for obtaining such a description, particularly when significant nonlinear effects are present. It involves measurement of the relationship, nonlinear or linear, between force transmitted through a joint and the relative displacement and velocity across it. An apparatus and procedure for force state mapping are described. Results are presented from tests of joints used in a lightweight, composite, deployable truss built by the Boeing Aerospace Company. The results from the joint tests are used to develop a model of a full 4-bay truss segment. The truss segment was statically and dynamically tested. The results of the truss tests are presented and compared with the analytical predictions from the model.

EXPERIMENTAL CHARACTERIZATION OF DEPLOYABLE TRUSSES AND JOINTS

INTRODUCTION

This presentation describes preliminary results of some work that is currently being performed jointly by the Boeing Aerospace Company (BAC) and CSA Engineering Inc. The work performed was partially funded by Marshall Space Flight Center (MSFC) Contract NAS8-36420 "Development of Structural Dynamic Analysis Tools" under the direction of Ron Jewell, Tulon Bullock, and Carlton Moore. The deployable truss structure was designed and fabricated as part of a BAC IR&D program.

As shown in Figure 1, the objective of the work performed was to identify and develop experimental methods to obtain the data required to analytically model the nonlinear behavior of joint dominated truss structures. Briefly, the approach we employed was to utilize a compact deployable truss structure that was fabricated under a separate IR&D program. We identified several techniques to model individual joint behavior for incorporation into an overall truss model. The method selected as being most appropriate for our purposes was based on the Force State Mapping technique developed by Prof. E.T. Crawley of M.I.T. The required testing of the individual joints was performed to characterize the joint behavior. An analytical model of a complete 4-bay truss was developed, and static and modal survey testing of the structure performed. The subsequent analysis/test correlation yielded several interesting conclusions regarding the analysis and testing technique, and the truss design which will be summarized.

BAC COMPACT DEPLOYABLE SPACE TRUSS

A picture of the fully deployed space truss is shown in figure 2. This truss was chosen not only because of its availability, but also because it was anticipated that the static and dynamic behavior would be dominated by the joints. In order to obtain a compact packaging ratio, hinged joints were incorporated at the midpoints of all horizontal members to allow them to fold. Deployment springs and a clothes pin type latching mechanism are designed into the hinged joints. Clevis joints are used at all five apex positions of the basic pentahedral truss bay. The 1 meter square bases of the pentahedrons are stabilized with crossed tension rods that pivot at their midpoints and ends. The rods are molded solid 0.125 inch diameter unidirectional graphite/epoxy. All of the truss fittings are discontinuous graphite fiber injection-molded thermo plastic resin. The 1 inch diameter truss tubes are graphite/epoxy and are designed for high stiffness, low weight, and near zero coefficient of thermal expansion.

TRUSS DEPLOYMENT SEQUENCE

Figure 3 depicts the deployment sequence of the 4-bay truss. As was mentioned previously, the truss was designed to provide a very compact packaging ratio. The truss which is nominally 4 meters x 1 meter x 0.71 meters when fully deployed, will fold up to a compact package which is 0.55 meters x 0.2 meters x 1.1 meters. The figure shows the truss fully folded, 50% deployed and fully deployed.

Introduction

ORIGINAL PAGE IS
OF POOR QUALITY

- Objective - Develop experimental methods to obtain data required to analytically model nonlinear joint dominated truss structures
- Approach
 - Fabricate compact deployable truss structure
 - Identify technique to represent individual joint behavior
 - Perform joint testing to develop data required to characterize joint behavior
 - Develop analysis model of complete truss structure
 - Perform static and modal survey testing of truss
 - Correlate test/analysis results
- Conclusions
- Work performed partially under MSFC contract NAS 8-36420 "Development of Structural Dynamic Analysis Tools"

FIGURE 2

BAC Compact Deployable Space Truss

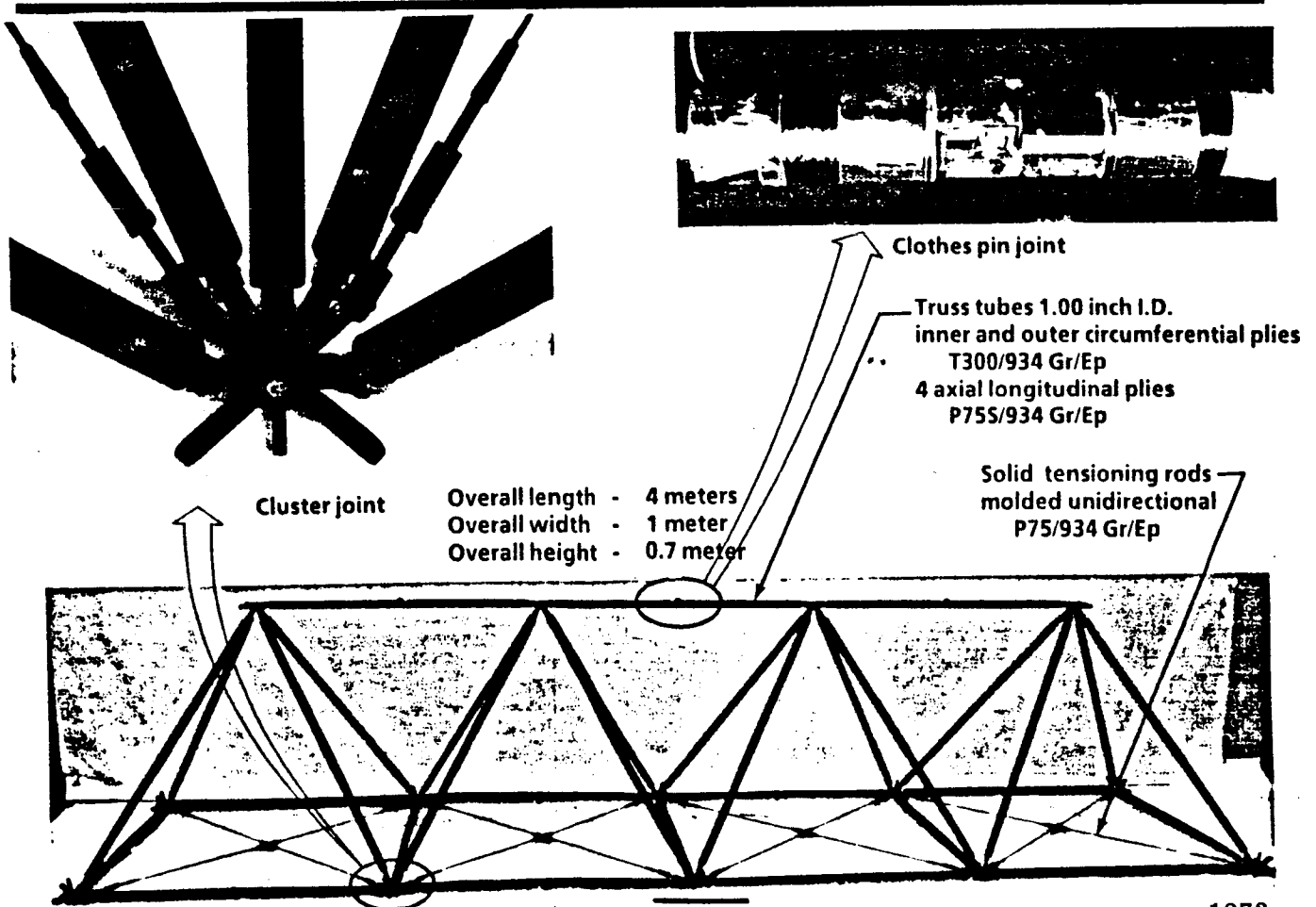

FIGURE 3
**BAC Deployable Space Truss-
Deployment Sequence**

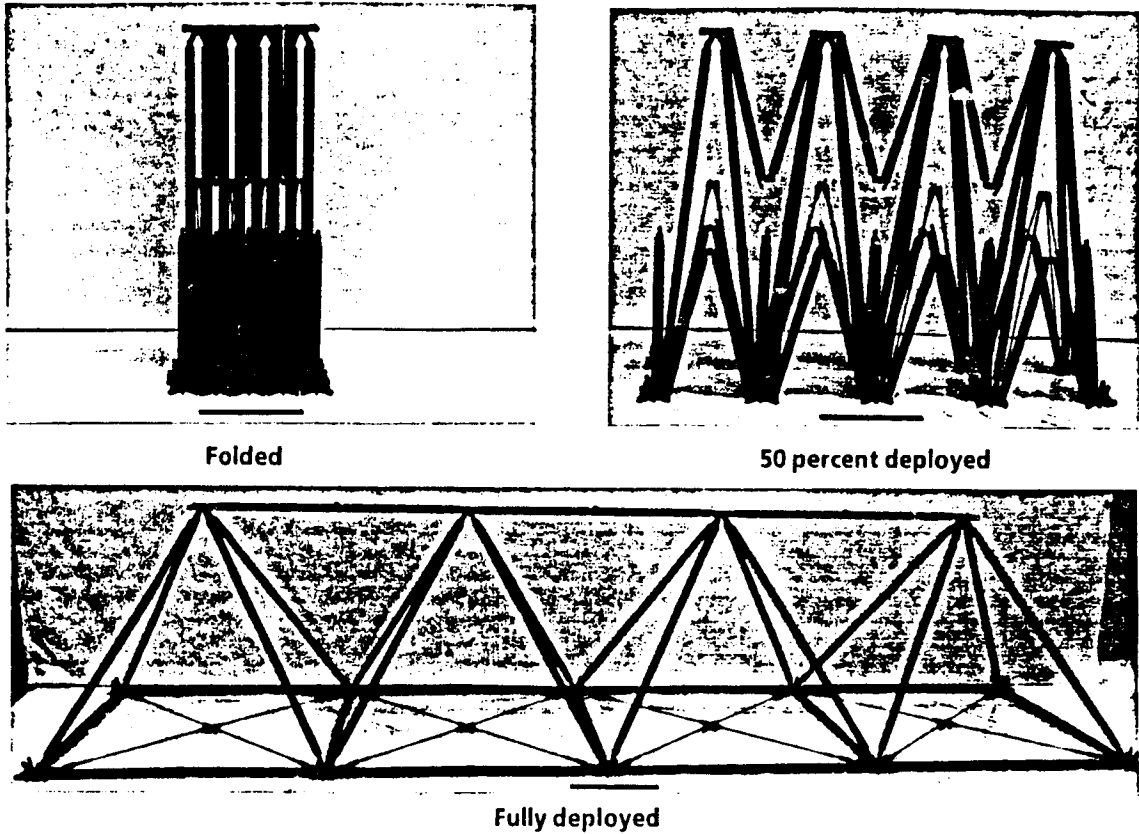
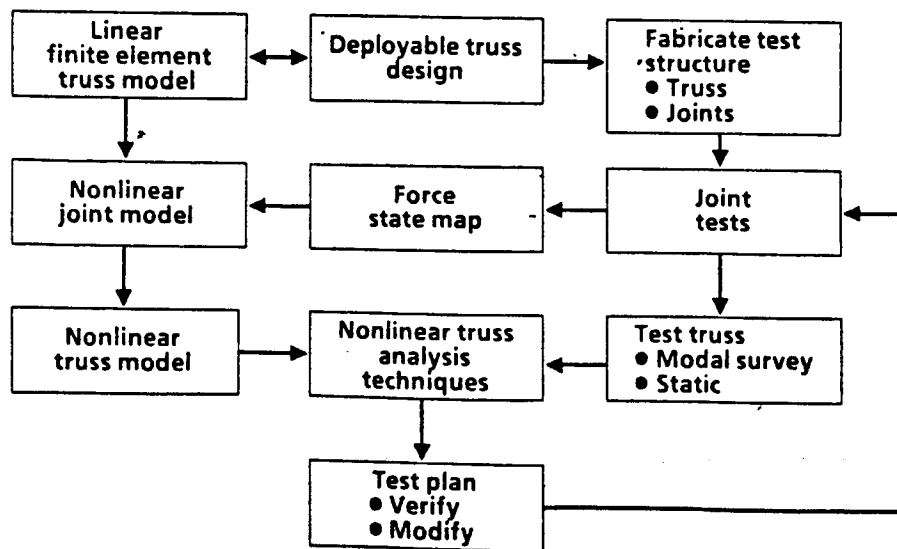

FIGURE 4

Truss Testing/Modeling Approach



TRUSS TESTING/MODELING APPROACH

The approach that was taken in the development of a truss testing/modeling technique is shown in flow diagram form in figure 4. A linear finite element model of the truss was formulated to aid the truss design effort. The 4-bay truss structure was then fabricated along with several extra joints to be used in the joint characterization tests. Force state maps, described in figure 5, were developed from the joint test data. The maps were then used to in the formulation of nonlinear models of both types of truss joints. These models were then incorporated into a model of the 4-bay truss. An analysis was then performed to correlate with the results of static and modal survey tests of the truss. The test/analysis correlation indicated that the original test plan will require several modifications.

JOINTS CHARACTERIZATION - FORCE STATE MAPPING

Figure 5 gives a description of the Force State Mapping technique developed by Prof. E.F. Crawley and K.J. O'Donnell at the MIT Space Systems Laboratory. This technique represents the force transmitted through a joint as a function of the relative displacement and velocity across the joint. The resulting three dimensional plot provides a very compact, graphical description of the joint behavior. Common nonlinearities associated with joints produce surfaces that are easily recognizable which can give the analyst a qualitative idea for an applicable joint model. As an example, the Force State Map for a linear spring-damper in series with a gap is shown. A well defined testing procedure has been outlined to implement the technique. The results are also in a form in which tangent or secant moduli can be readily calculated to be used in equivalent linearization analyses.

CLEVIS JOINT TEST SETUP

A picture of the joint testing apparatus setup for the testing of the deployable truss clevis joint is shown in figure 6. The joint was held between a heavy steel "bookend" load reaction fixture and the armature of an electro-mechanical shaker. The shaker and fixture were bolted to a concrete slab floor. The force was applied to the joint along the axis of the truss tube leading into the joint. Displacement and velocity were sensed in the direction parallel to the applied load. The input force was sensed by a Kistler Model 922F3 piezoelectric force cell. The relative displacement across the joint was sensed with a Trans-Tek Model 240-0000 integrated linear variable differential transducer (LVDT), and the relative velocity across the joint with Trans-Tek Model 0101-0000 linear velocity transducer (LVT).

SCHEMATIC OF INSTRUMENTATION FOR FORCE-STATE MAPPING TESTS

Figure 7 shows a block schematic of the data acquisition system. The main components are a Zonic Model 6080 multichannel FFT analyzer and an LSI 11/73 minicomputer system. The 6080 provided the antialiasing filters, A/D conversion, and real-time DMA throughput of data to hard disk. Following acquisition, the raw time history data was moved to a VAX 11/750 for force map processing. The three quantities of interest, force, displacement and velocity, were measured using three separate transducers. The controlled force input was an amplitude-modulated sine wave with a "carrier" frequency of 2 Hz. The modulating signal was a ramp function having a period of 120 seconds.

FIGURE 5

Joints Characterization-Force State Mapping

- Reference: "Identification of Nonlinear System Parameters in Space Structure Joints Using The Force State Mapping Technique", E. F. Crawley and K. J. O'Donnell SSL #16-85, July 1985

- Represents force transmitted by joint as function of displacement and velocity across joint
- 3 dimensional plot provides compact graphical description of nonlinear joint behavior
- Established testing procedure
- Common nonlinearities easily recognizable
- Results directly usable for equivalent linearization analysis

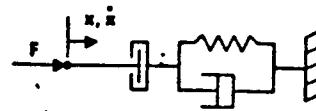

Force state map for spring-damper with gap

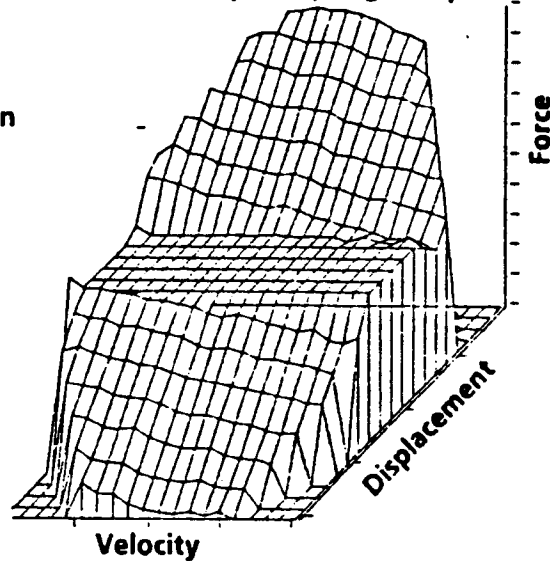

FIGURE 6

Clevis Joint Test Setup

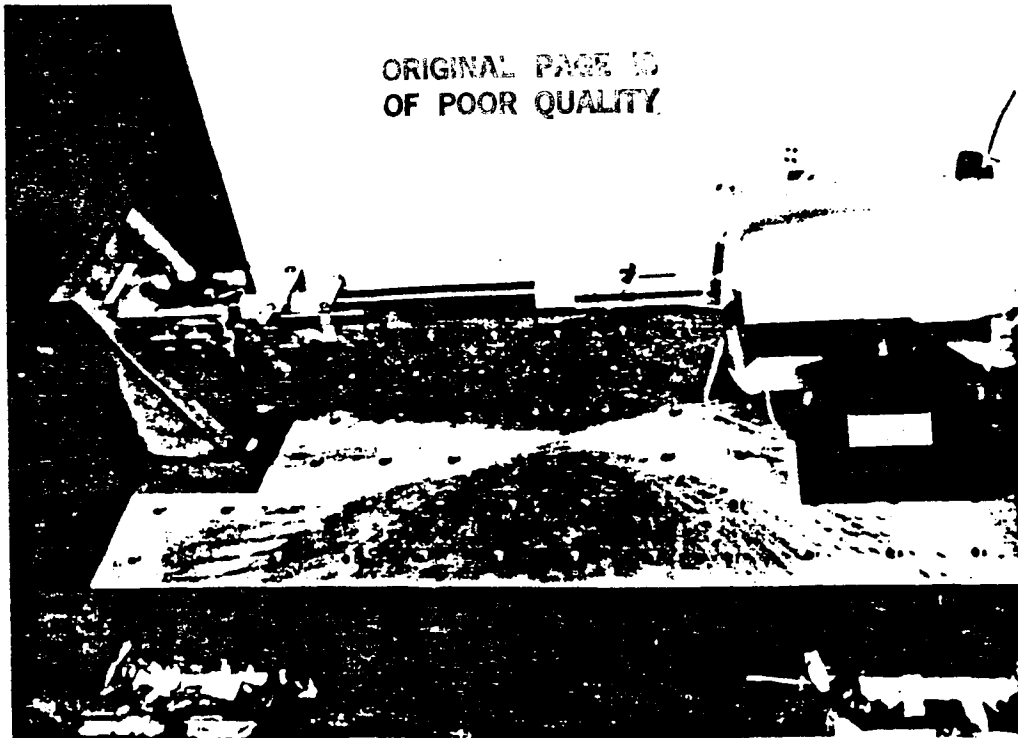

FIGURE 7

Schematic of Instrumentation for Force State Mapping Tests

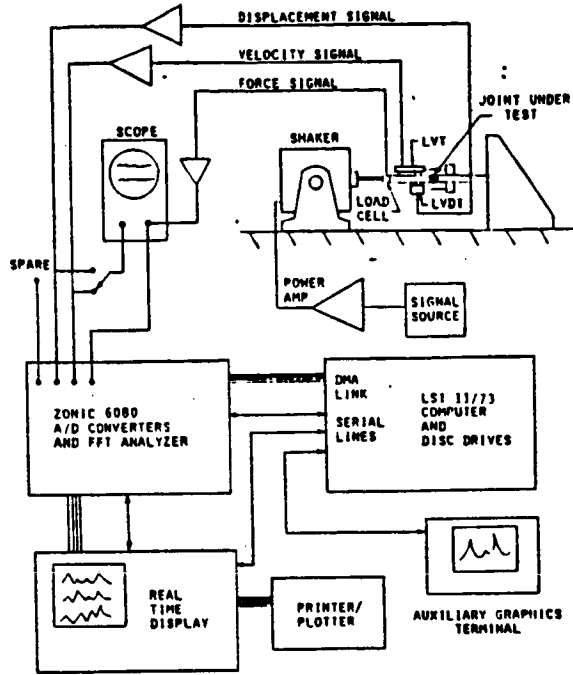
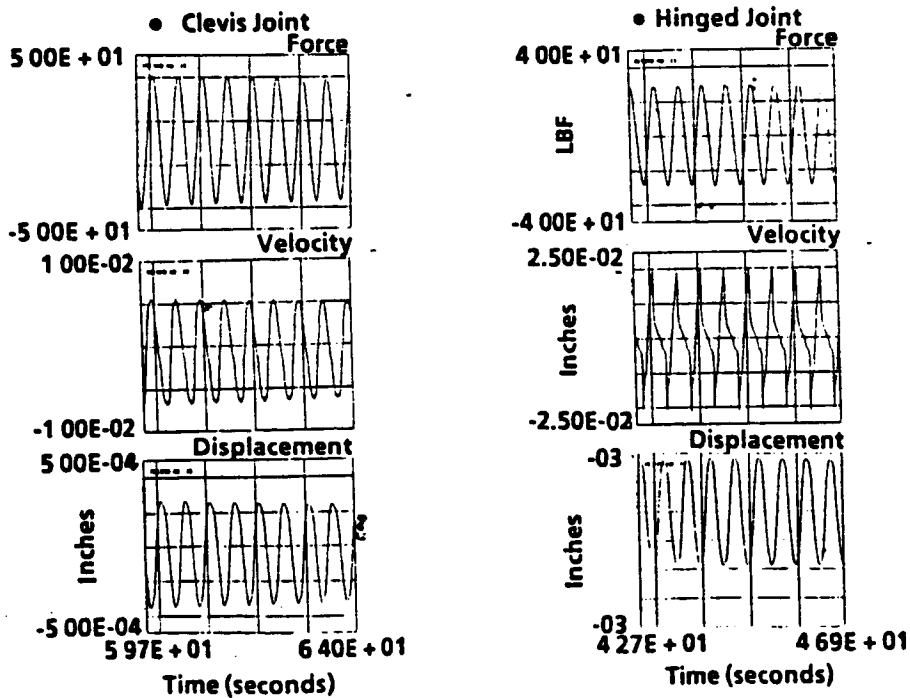

FIGURE 8

Raw Data From Joint Testing at 2 Hz



RAW DATA FROM JOINT TESTING AT 2 Hz.

The plots in figure 8 show segments of the raw time histories of force, velocity and displacement from tests of the clevis joint and hinged joint. Both the tongue and clevis fitting were fabricated of the injection-molded fiber-resin. Note that the force, velocity and displacement data for the clevis joint all appear to be sinusoidal, indicating that the clevis joint is essentially linear. The hinged joint however exhibited a more nonlinear behavior. Because the hinge axis does not intersect the axis of the tube, a bending moment around the hinge axis results when axial forces are applied to the tube. Although lateral motions of the joint were constrained by the test fixture, it is to be expected that some bending of the joints occurred. While the effect could not be eliminated, it was quantified by running the test with the transducers located at several different positions around the tube axis. It can be noted that the quantity which varies the most from a sinusoid is the velocity signal.

REDUCED FORCE STATE DATA FOR CLEVIS JOINT AT 2 Hz

A force-state map and a hysteresis curve of the clevis joint is shown in figure 9. The results were derived from the complete, amplitude-modulated time histories, a short segment of which was shown in the previous figure. Note that the surface is not perfectly flat, indicating that some amount of nonlinearity and energy dissipation are present. The hysteresis curve of the clevis joint shows force versus displacement for one load cycle at each of three peak load levels. It clearly shows that the joint is capable of dissipating a significant fraction of its peak energy in each cycle and that this dissipated fraction (proportional to damping) is a strong function of load level.

REDUCED FORCE STATE DATA FOR HINGED JOINT AT 2 Hz

The force-state map for the hinged joint is shown in figure 10. The characteristics of the joint were such that certain areas in the position-velocity plane could not be measured. The shape of the surface indicates a more pronounced nonlinear behavior than was noticed for the clevis joint. The corresponding hysteresis plot is also shown. The displacement offset is due to error in the DC-coupled transducing. As with the clevis joints, it can be seen that the hinged joint also exhibited a significant amount of damping.

DEPLOYABLE TRUSS STATIC AND MODAL SURVEY TEST SET-UP

Figure 11 shows the 4-bay deployable truss set-up for the static and modal survey testing. The truss was tested in a cantilevered configuration, mounted vertically with the fixed end at the floor of the test cell. A 208 lb triangular tip mass was attached to the free end of the truss to decrease the structure modal frequencies. A pendulum suspension was used to off-load the 208 lb weight to eliminate any preload effects. During testing, the amount of off-load could be varied to assess the effects of a compressive joint preload. Electro-magnetic shakers were used to drive the tip mass for the modal survey tests, and a pulley/weight system was used to apply the forces for the static test. Modal shape data was obtained from 72 accelerometers mounted to the truss and tip mass. Deflection indicators were used to measure the displacement of the centroid of the tip mass during the static tests.

FIGURE 9

Reduced Force State Data for Clevis Joint at 2 Hz

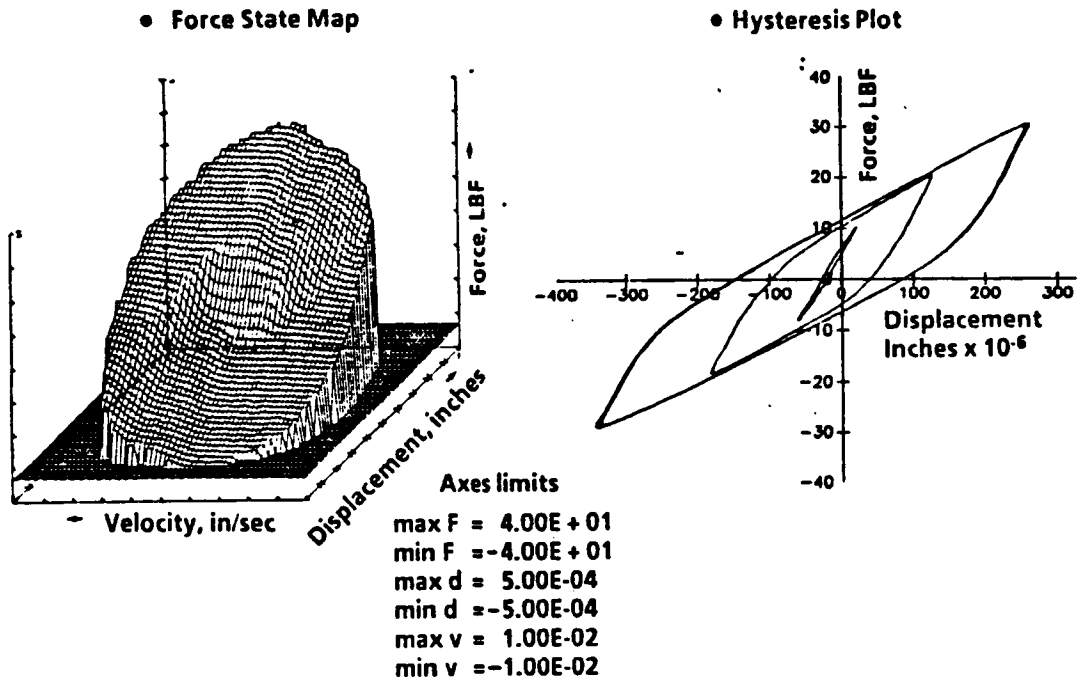

FIGURE 10

Reduced Force State Data for Hinged Joint at 2 Hz

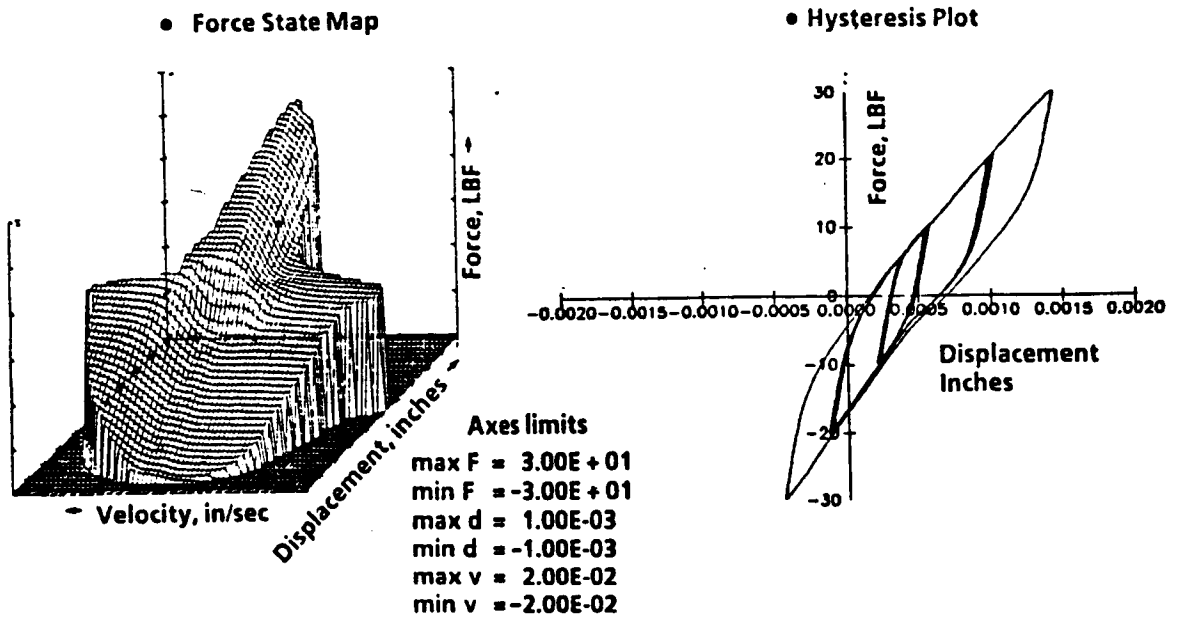

FIGURE 11
Deployable Truss Modal Survey and Static
Test Set-Up



FIGURE 12

Truss Modal Survey Accelerometer Installation

- 72 Accelerometer measurements
- All clevis joints
- Hinged joints on one longeron

ORIGINAL PAGE IS
OF POOR QUALITY

- Single axis
- △ Triaxis

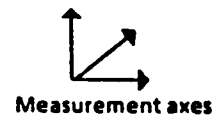
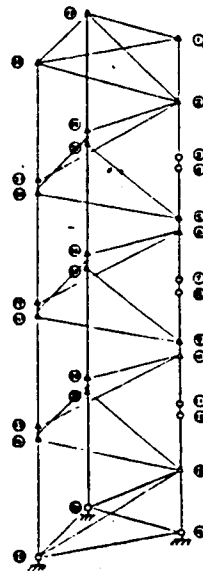

TRUSS MODAL SURVEY ACCELEROMETER INSTALLATION

The accelerometer installation for the truss modal survey tests is shown in figure 12. A total of 72 accelerometer measurements were made. The accelerometers were generally mounted in triaxial configuration adjacent to joints on small plexiglass mounting blocks. For several of the clevis joints, a triaxial set was mounted on both sides of the joint to measure joint rotation effects. Single axis lateral acceleration measurements were also made on both sides of the hinged joints along one longeron. All truss mounted accelerometers were lightweight, Endevco Models 2222 or 2250. Other locations utilized PCB Model 308 type. All accelerometers were mounted parallel to the rectangular X,Y,Z measurement axes system.

TRUSS MODAL SURVEY BENDING MODE SHAPES

Mode shape data for the first two lowest truss modes obtained from the modal survey testing are plotted in figure 13. These two modes were the cantilever bending modes in the Y and Z directions, respectively. In both of these mode shape plots, a significant amount of rotation of the clevis joints and lateral buckling at the hinged joints can be noticed. This behavior is most pronounced in the single longeron on the left side of the truss only because it contained the most instrumentation. The joints in the other longerons were observed to exhibit a similar behavior. This differed significantly from the strictly axial deformations that are generally expected in truss longerons.

TRUSS MODAL SURVEY TEST/ANALYSIS MODAL FREQUENCIES

A comparison of the modal frequencies obtained from the modal survey test and those predicted by a linear finite element modal analysis performed in NASTRAN is given in figure 14. The NASTRAN finite element model is also shown. Beam elements with pinned connections were used to model the truss members. The clevis joints were also modeled in detail with beam elements. The hinged joints, however, were assumed to be rigid. It can be seen that the analysis significantly overpredicted the frequencies of all of the overall truss modes. This is due primarily to the flexibility introduced by the lateral buckling of the longeron hinged joints. The effects of clevis joint rotation were modeled fairly well as can be seen by the comparisons with the joint rotation modes obtained in the modal survey test. A possible secondary effect on the overall flexibility of the test structure that was not modeled is the joint rotation that may be caused by an initial angular misalignment of the clevis joints. The lateral buckling and joint rotation effects cannot be readily incorporated into an analytical model and should be eliminated in the truss design process if an accurate model of the truss is needed.

TRUSS MODAL SURVEY VARIATION OF MODE FREQUENCY WITH FORCE AMPLITUDE

Figure 15 shows the variation of test frequencies for the first Y-bending mode for different shaker force levels. A narrow band sine sweep technique was used to map the test modes. The total shaker force was varied from 1.0 to 3.0 lbs rms. Tests were run with the truss structure completely off-loaded, and also with a total axial compressive preload of 50 lbs. In both cases, the mode frequencies decreased with increased shaker force. This is consistent with the behavior noticed in the joint tests, figures 9 and 10, in which it could be seen from the hysteresis plots that the joints appear to be stiffer at the lower load levels.

FIGURE 13

Truss Modal Survey Bending Mode Shapes

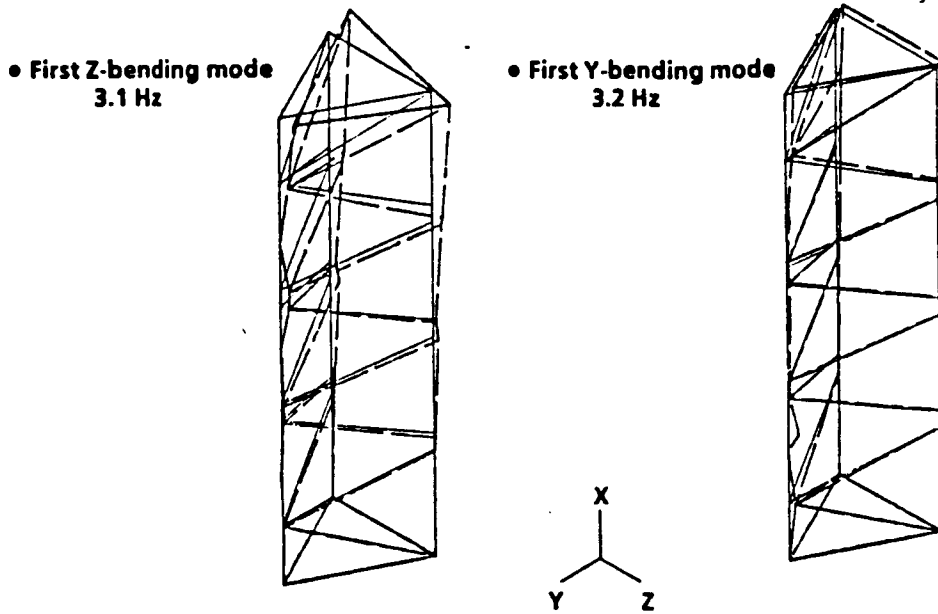

FIGURE 14

Truss Modal Survey Test/Analysis Modal Frequencies

Mode	Frequency-Hz	
	Test	Analysis
First Z-bending	3.1	4.4
First Y-bending	3.2	4.6
First axial	21.0	28.7
Torsion	9.5	14.6
Clevis joint rotation	15.4	15.3
Clevis joint rotation	19.6	17.1

- Nastran linear finite element modal analysis
- Beam elements with pinned connections
- Clevis joints modeled

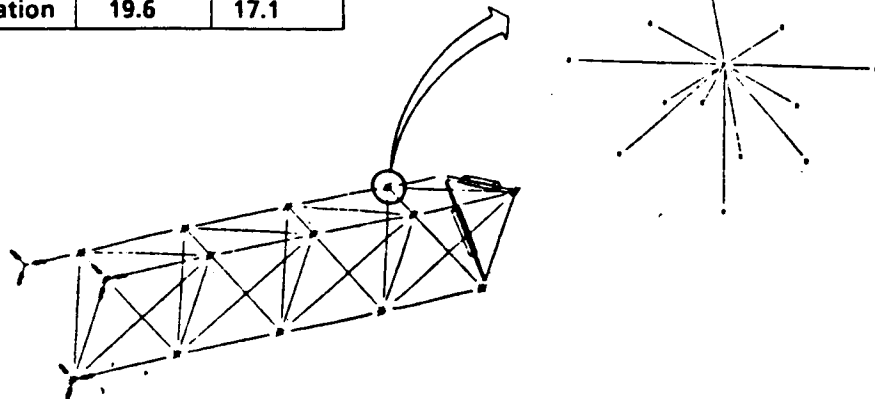

FIGURE 15

Truss Modal Survey Variation of Mode Frequency With Force Amplitude

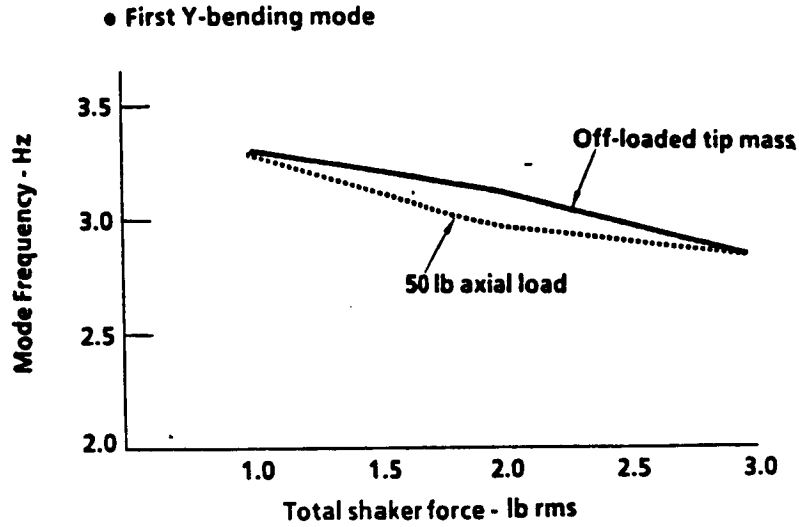
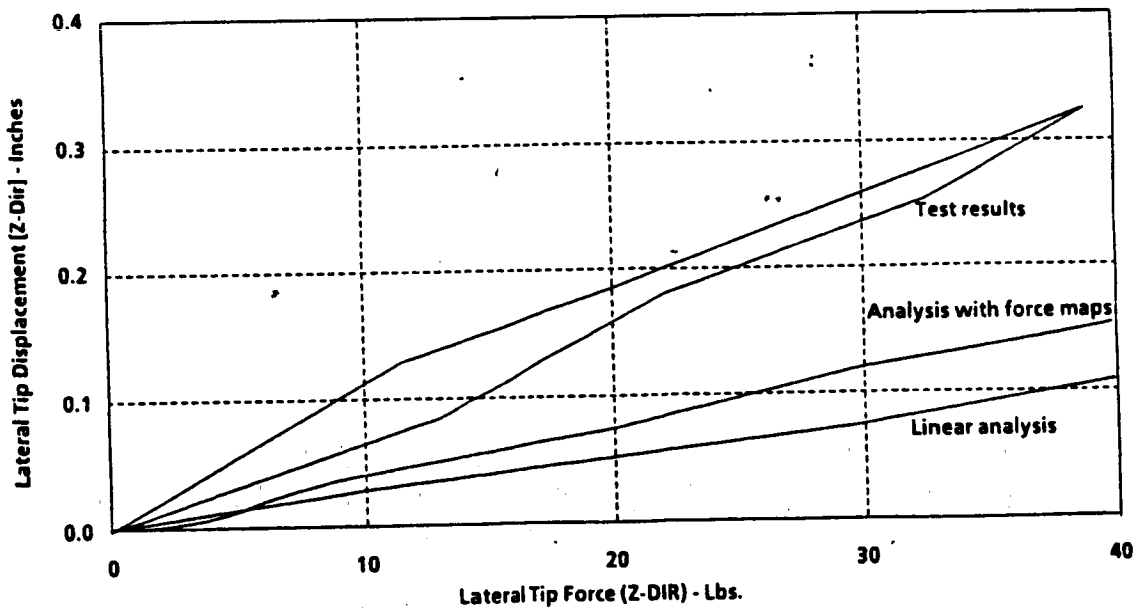

FIGURE 16

Truss Static Test/Analysis Comparison



TRUSS STATIC TEST/ANALYSIS COMPARISON

The deflection at the tip of the truss in the Z-direction as a static loading of up to 38.7 lbs was first applied then removed is shown in figure 16. Some nonlinearity and hysteresis was noticed in the test data. For comparison purposes, first a linear static analysis was performed in NASTRAN using the finite element model shown in figure 14. As was observed in the modal survey results, the linear analysis model significantly overpredicted the stiffness of the truss structure. A second analysis was then performed incorporating the force state map data shown in figures 9 and 10 for the models of the clevis and hinged joints. The force maps were included in a residual force modal nonlinear analysis (reference: "Dynamics of Trusses Having Nonlinear Joints", by J. M. Chapman, F. H. Shaw, and W. C. Russell, presented previously at this workshop), in which only the stiffness components of the force maps at zero velocity were included. In the analysis, the load was ramped slowly from 0 to 40 lbs. The results are shown plotted in the figure. Although the correlation with the test data is closer than the strictly linear analysis, the analysis with the joint force maps still significantly overpredicts the truss stiffness.

TRUSS STATIC TEST COMPARISON - EFFECTS OF HINGE JOINT LATERAL BUCKLING

An analysis was performed incorporating the combined effects of axial deformation, hinged joint rotational gap and flexibility, and cable tension and end shortening due to bending using the residual force nonlinear analysis technique. The results are shown plotted in figure 17. The most sensitive parameters were found to be the hinge joint rotational stiffness and the gap. The 5000 in-lb/Rad rotational stiffness used in the analysis was felt to be conservative for the hinge joint. This analysis produced a much closer correlation with the test data than the linear finite element analysis, although it still over predicts the truss stiffness.

TRUSS STATIC TEST COMPARISON - EFFECT OF CLEVIS JOINT ROTATION

A NASTRAN geometric nonlinear analysis, including large deformation effects, was performed to assess the effects of having an initial angular misalignment of the clevis joints. Assumed 2 degree clevis joint rotations were written into the unstressed geometry, and runs were made with static loadings of 10, 20, 30, and 40 lbs. The resulting truss tip displacements are shown in figure 18. Again, the results are much closer to the test data than the linear analysis; however, the overall truss stiffness is still overpredicted. As was noticed in the discussion of the modal survey results, the flexibility of the test structure is probably due to the combined effects of hinge joint lateral buckling and clevis joint rotation.

CONCLUSIONS

In summary, several conclusions were drawn as a result of this work regarding the design of the deployable truss, and the testing and analysis of nonlinear joint dominated trusses. As shown in figure 19, the first conclusion was that a study of the load path through the truss joints in tension and compression should be performed early in the design process to determine the susceptibility of the joint to rotation or lateral buckling. This behavior decreases the overall stiffness and generally makes it impossible to develop an accurate analytical model of the truss structure. Since the hinged type folding joints are particularly

FIGURE 17

Truss Static Test Comparison-Effect of Hinge Joint Lateral Buckling

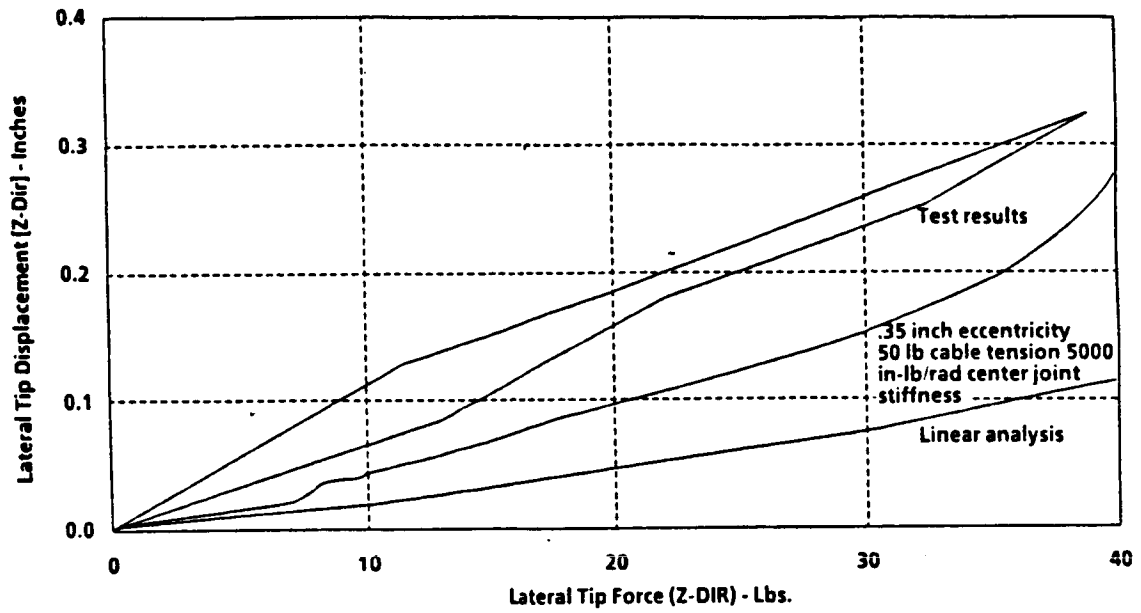
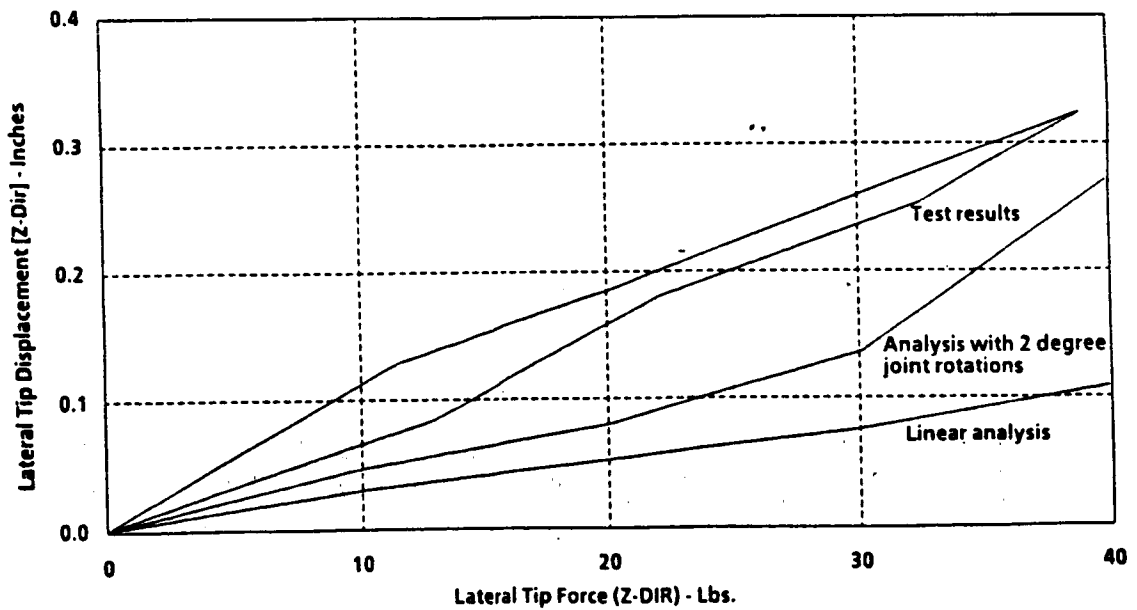

FIGURE 18

Truss Static Test Comparison-Effect of Clevis Joint Rotation



Conclusions

- **Deployable truss design**
 - **Joints designed without consideration of load path can exhibit rotation or lateral buckling**
 - **Introduces structural flexibility**
 - **Impossible to characterize in analytical model**
 - **Avoid hinged type folding joints in longeron members**
- **Truss testing/analysis**
 - **Force state mapping excellent technique for characterizing joints**
 - **Straight forward test method**
 - **Compact representation of joint behavior**
 - **Link testing may be required to describe truss behavior and verify analytical models**
 - **Fabrication and testing of subscale models or links should be required during design development**

susceptible to lateral buckling due to the eccentric load path of the truss should be avoided if possible.

The force state mapping has proven to be an excellent technique for characterizing the nonlinear behavior of joints. The required instrumentation and test methods are relatively straightforward and do not present any unique problems. The 3-dimensional force state map provides a compact qualitative and quantitative method of representing the test data required to define the joint behavior. However, due to the possibility that some of the joint degrees of freedom may be unintentionally constrained during the joint test, a link test involving several joints and truss members in series may be required to completely describe the truss behavior and verify analytical models. It is therefore recommended that the fabrication and testing of scaled truss models or links be performed during the design development to identify joint problems, especially if an accurate analytical model of the truss structure will be required.

The need for monitoring the dynamic characteristics of large structural systems for purposes of assessing the potential degradation of structural properties has been established. This paper develops a theory for assessing the occurrence, location, and extent of potential damage utilizing on-orbit response measurements. Feasibility of the method is demonstrated using a simple structural system as an example.