

AM

Dual-Polarization 8.45 GHz Traveling-Wave Maser

R. B. Quinn

Radio Frequency and Microwave Subsystems Section

An 8.45 GHz dual-channel, dual-polarization traveling-wave maser (TWM) amplifier has been installed in the XKR solar system radar cone at DSS 14. The TWM is based on the Blk IIA 8.45 GHz maser structure, with two of the four maser stages being used for each channel, and each maser half then followed by a high-performance GaAs FET amplifier to achieve the desired net gain. A new shortened low-noise input waveguide and an orthogonal-mode junction which is cooled to 4.5 K feeds each amplifier chain. The rotation of an external polarizer permits the polarization of each channel to be defined as either linear or circular. A new circular waveguide switch was also developed to provide for noise calibration and to protect the maser from incident transmitter power.

I. Introduction

The need by radio astronomers to receive simultaneous 8.495 GHz radar signals of right- and left-hand circular polarization prompted the design and installation into the XKR cone at DSS 14 of an 8.45 GHz dual-channel, dual-polarization traveling-wave maser/closed-cycle refrigerator system (TWM/CCR) which replaced the original single channel TWM/CCR. The new system has the following characteristics: (1) two channels with a center frequency of 8.45 GHz, a net gain of ≥ 45 dB, and an instantaneous bandwidth of 100 MHz, (2) polarization of either channel selectable to right-circular polarization (RCP), left-circular polarization (LCP), or linear polarization, (3) system noise temperature of 20 K or less, and (4) use of the existing feedhorn and rotary polarizing section.

II. Description

The block diagram of the new TWM/CCR system developed for this project is shown in Fig. 1. It was determined that the requirements could be best met by dividing a Blk II 8.45 GHz maser into two channels of two maser channels each, and

incorporating an orthomode junction into the cryogenic package, along with the maser amplifier structure. Therefore, only one waveguide input and vacuum window through the CCR interface would be required. The microwave feed system in the center position of the XKR cone provides separation of RCP and LCP by means of a rotating quarter-wave polarizing section and an orthomode junction. By indexing the polarizing section 90 degrees, the channel through which each signal (RCP or LCP) is amplified can be changed. A new and smaller orthomode junction was purchased from Altantic Microwave Corporation. Because of the reduced size of this device, it was possible to place it inside the CCR, where it would operate at 4.5 K, thus reducing its noise contribution. The existing feedhorn interface and polarizing section are 3.48 cm diameter circular waveguide. A smaller waveguide diameter was used in the design of the waveguide switch, vacuum window, and low-noise input structure in order to minimize the probability of RF mode conversion that might occur if the larger waveguide was used. An adapter was designed and supplied to join these two different size waveguides. The signal outputs come out through a pair of 0.36 cm diameter coaxial cables to hermetically sealed SMA connectors at the CCR vacuum interface. Two

other SMA connectors are available to couple noise calibration signals or test signals into the maser inputs via cryogenically cooled -30 dB directional couplers. A high-performance, low-noise GaAs FET post amplifier follows each maser channel to achieve the desired net gain.

A. Traveling Wave Maser Assembly

The Blk IIA maser structure [1] is made up of four independent stages operating in a single superconducting magnet assembly and joined in series by coaxial semirigid cables. It was thus possible to divide the maser into two separate maser channels of two adjacent stages each. The maser gain and bandwidth of each channel is adjusted as a single unit by shaping the applied magnetic field to achieve an average gain of 8 to 10 dB per stage and a -3 dB bandwidth of >100 MHz.

B. Closed-Cycle Refrigerator Assembly

The entire maser/magnet assembly is cooled by 4.5 K by the same closed-cycle helium refrigerator (CCR) that is used in the Blk IIA systems. Modifications of the assembly were made to provide for maser output and noise calibration input signals and for the inclusion of the orthomode junction. The modification consisted of replacing the Blk IIA output waveguide and the 4-K station support with two tubular support assemblies, through which the four coaxes enter the CCR. The radiation shields were redesigned to provide room for the added components and a heat strap was added for conduction cooling of the orthomode junction to 4.5 K. As was the case for the Blk IIA maser, the radiation shields were nickel-plated to protect the copper surfaces and reduce the radiant heat load on the CCR. When the refrigeration capacity measured lower than expected on this dual-channel system, it was discovered that electroless nickel rather than electroplated nickel had been applied to the shields. The result was a surface having poor infrared reflectivity. The infrared reflectivity was improved and the refrigeration capacity increased by gold-plating the shields. Reserve capacity measurements were made before and after gold-plating and with and without the low-noise input waveguide structure and orthomode combination. The results are shown in Table 1.

Cryogenic temperature sensors from Lake Shore Cryotronics were installed in the CCR to measure the three refrigerator stage temperatures. Presently, there is no provision to monitor these sensors in the control rack, but the stage temperatures can be measured locally during maintenance.

C. FET Post-Amplifiers

Two high performance GaAs FET amplifiers were purchased from Berkshire Technologies, Inc. The FETs were opti-

mized for operation at room temperature and have an ambient noise temperature of <125 K. Each amplifier has an isolator on the input and output connectors to provide unconditional stability and to improve the VSWR. The amplifiers are mounted on the TWM/CCR mounting brackets on each side of the CCR. The power supplies for the amplifiers are built into a common enclosure that is mounted to the side of the maser package.

The original system design called for cryogenic cooling of the post-amplifiers, but the performance of the maser exceeded that of the average Blk IIA maser, making the use of post-amplifier cooling unnecessary. Placing the post-amplifiers outside the CCR resulted in a higher reserve refrigeration capacity and hence a more reliable maser system.

D. Orthomode Junction

A special orthomode junction was made for JPL by Atlantic Microwave Corporation since the DSN's primary frequency range of 8.4 GHz to 8.5 GHz fell between their standard catalog models. The assembly is copper-plated for low electrical loss. The device provides isolation between cross-polarized components of >40 dB and a VSWR of better than 1.15:1.

E. Low-Noise Input Waveguide Assembly

A new shortened input waveguide assembly was designed to allow for the added length of the orthomode junction within the same CCR vacuum housing. A cross-section diagram of the new assembly is shown in Fig. 2, and a photograph of the assembly with the cooled orthomode attached is shown in Fig. 3. Figure 3 also shows the existing Blk IIA low-noise input waveguide assembly for comparison. While the new design is shorter by $>50\%$, it provides an improvement in thermal isolation over the low-noise input assembly in the Blk IIA maser. This was achieved by replacing stainless steel construction with G-10 CR fiberglass as a rigid structural material. The normally poor infrared reflectivity of the fiberglass material was improved by vacuum-depositing approximately 1500 angstroms of gold. This assembly is able to maintain precise axial relationships between waveguide sections and maintain correct spacing of the RF choke joint gaps while minimizing the heat leak into the CCR through the structural material. As seen in Table 1, this input waveguide assembly (and orthomode junction) contributed 100 mW of heat load to the CCR.

F. Output Coax/Support Assembly

A pair of special coax/support structures was designed and installed in the CCR. These structures furnish structural support for the maser/magnet assembly while providing an enclosure and feed through location for the four coaxial cables and connectors required for signal output and calibration signal

input. The 0.36 cm diameter coaxial cable used for output lines and noise source input lines was especially chosen for cryogenic applications. It has an outer conductor of stainless steel and an inner conductor of silver-plated beryllium copper. This type of coax is desirable in cryogenic applications because of its low microwave insertion loss and relatively low thermal conductivity.

G. Waveguide Switch Assembly

A waveguide switch is required between the feedhorn and the maser to protect the maser and receiver from incident transmitted power. The waveguide switch is also used to switch the maser to an ambient termination for system noise calibration. In a conventional waveguide switch, such as those used in DSN receiving systems, a rotating member is used between the waveguide ports. This type of switching mechanism was not usable because of the mechanical and microwave performance difficulties associated with circular waveguide bends in a switch rotor. Therefore, a new kind of linear waveguide switch for circular waveguide was designed and built (shown in Fig. 4). A DSN-type drive mechanism (for compatibility with DSN control wiring) is used to move a sliding shuttle on linear bearings. At one end of the 5.08-cm travel, a through-path exists, while at the other end, the shuttle contains a tapered circular ambient termination (looking toward the TWM), and a short circuit (looking toward the feedhorn).

H. Wide Tuning Range Pump Source

The new TWM replaced a Blk I 8.45 GHz maser that had been used on occasion at frequencies outside those normally used by the DSN. The tuning range of the maser within the particular structure bandpass is determined by the tuning range of the pump source, which is an electronically tunable klystron or Gunn effect oscillator. The source used to pump the Blk IIA TWM uses a pair of Gunn effect oscillators designed to support maser operation from 8.4 GHz to 8.5 GHz. The oscillators are tuned by means of a negative biased varactor diode. The Radio Astronomy Group furnished funding for the purchase of specially designed Gunn effect oscillators that would allow the TWM to be tuned to the usual Blk IIA frequencies and also to 8.67 GHz. This higher frequency is re-

quired for the Interstellar Microwave Spectroscopy task. The new oscillators, made by Central Microwave Corporation, are unlike the Blk IIA oscillators in that they require a positive tuning varactor voltage. The bias voltage change was accomplished by making wiring changes in the maser pump source and in the solid-state pump controller and by replacing the voltage protection/modulation assemblies in the pump source. Because of these changes, the pump source and controller for this TWM are now a matched pair and are not interchangeable with similar components in Blk IIA maser systems. This new pump source allows TWM operation from 8.4 GHz to 8.7 GHz, with approximately 100 MHz of bandwidth.

III. Performance

The gain/bandwidth curves and noise temperature measurements shown in Figs. 5 and 6 were measured in the laboratory prior to replacement of the cryogenically optimized post-amplifiers with those optimized for room temperature operation. The total gain is now about 4 dB less than shown, but the system noise temperature on the antenna was improved by 0.5 K, for a total system temperature of approximately 20 K.

The isolation between the two polarization channels was measured on the antenna with the use of a test probe mounted over the feedhorn. The isolation between RCP and LCP channels exceeded 17 dB.

IV. Conclusions

This new dual-channel, dual-polarization TWM system demonstrates the ability to incorporate more than one maser amplifier into one CCR and also to lower the total system temperature by the cryogenic cooling of components that had previously operated at room temperature. This accomplishment was due to improvements in FET post-amplifier noise performance, the availability of a compact orthomode junction, the design of a new cryogenic low noise input waveguide structure, and the development of a suitable waveguide switch in circular waveguide.

References

- [1] D.L. Trowbridge, "Block IIA Traveling Wave Maser," *TDA Progress Report 42-87*, vol. July-September 1986, pp. 158-164, Jet Propulsion Laboratory, Pasadena, CA, Sept. 15, 1986.

Table 1. Reserve CCR heat capacity

| | Without low-noise input assembly and orthomode junction | With low-noise input assembly and orthomode junction installed |
|---|--|--|
| Electroless nickel plating on copper radiation shields | 444 MW | 340 MW |
| After gold plating of radiation shields | 690 MW | 590 MW |

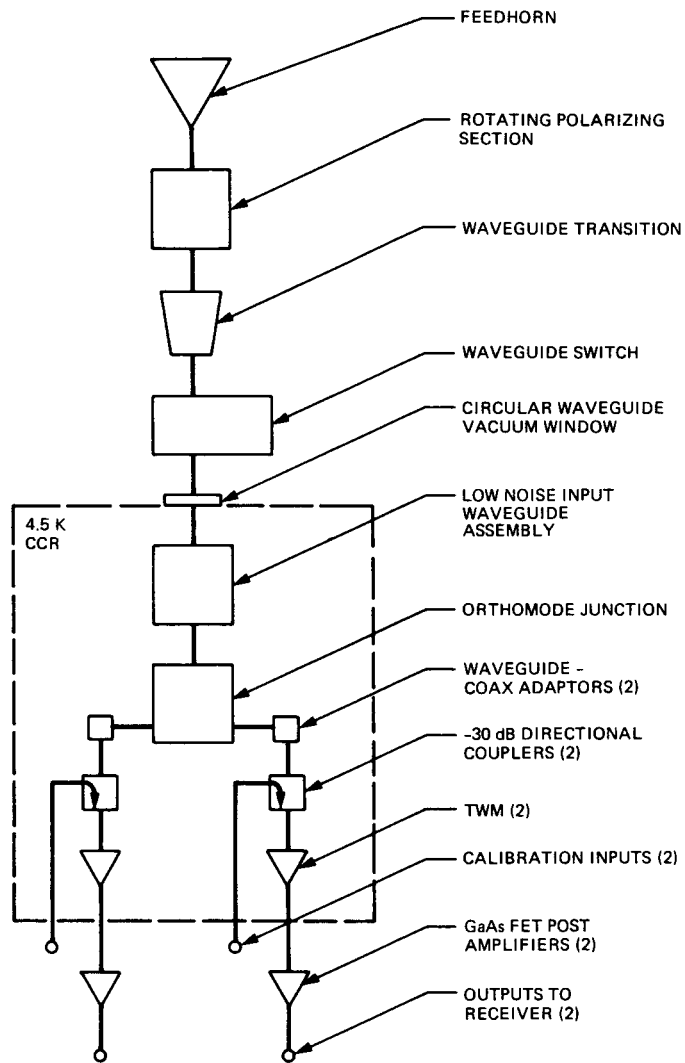

Fig. 1. Block diagram of 8.45 GHz dual polarization TWM/CCR

ORIGINAL PAGE IS
OF UNCLASSIFIED

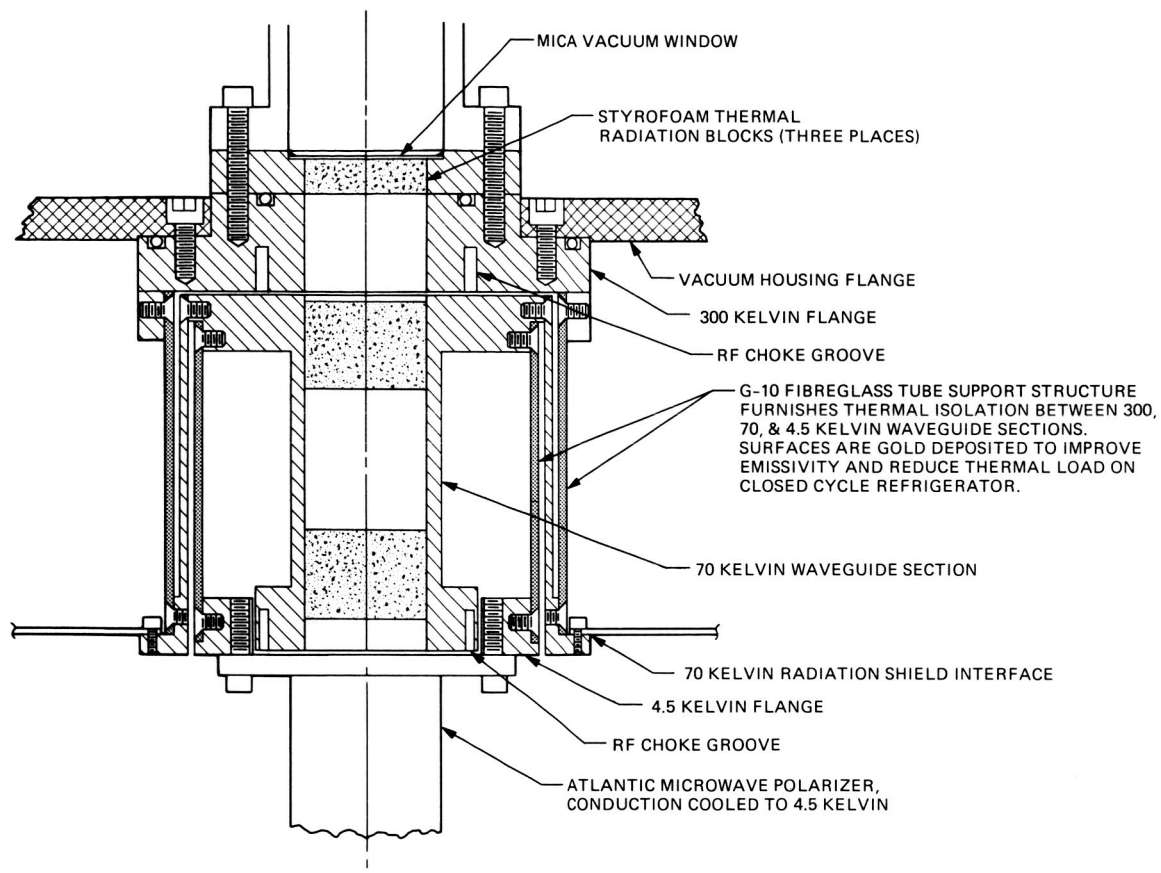

Fig. 2. Cross section of low noise input waveguide assembly

**ORIGINAL PAGE IS
OF POOR QUALITY**

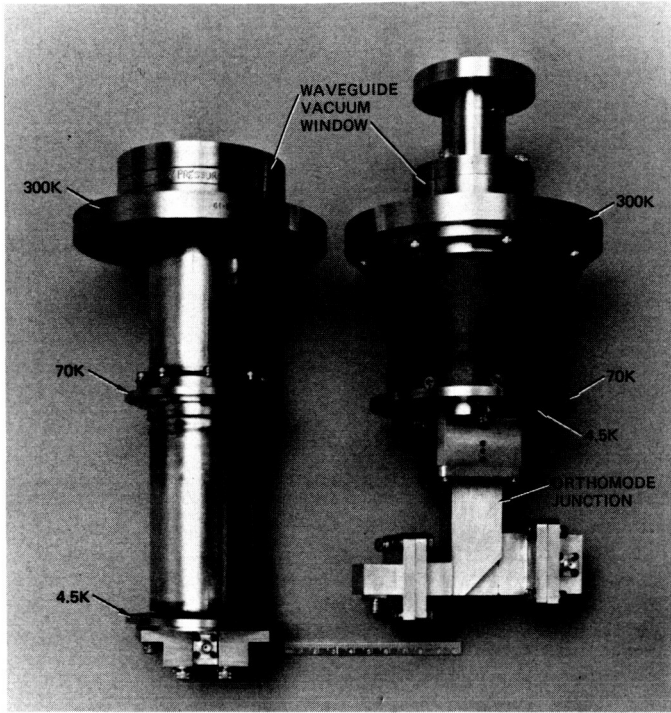

Fig. 3. New low noise input waveguide assembly and orthomode compared with BIK IIA low noise input waveguide assembly

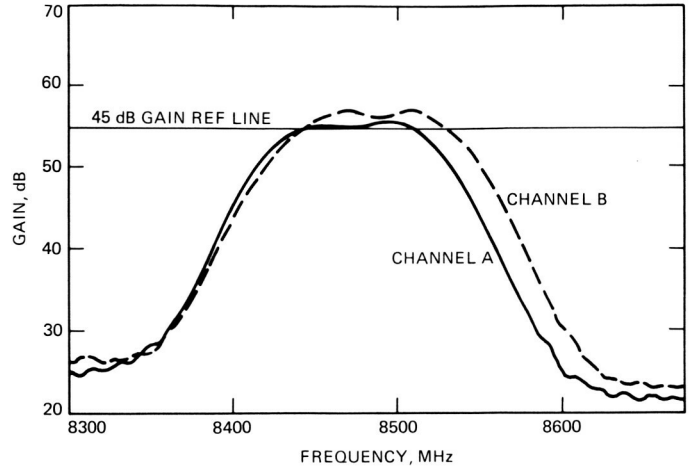

Fig. 5. Gain/bandwidth curves, TWM tuned to 8.495 GHz

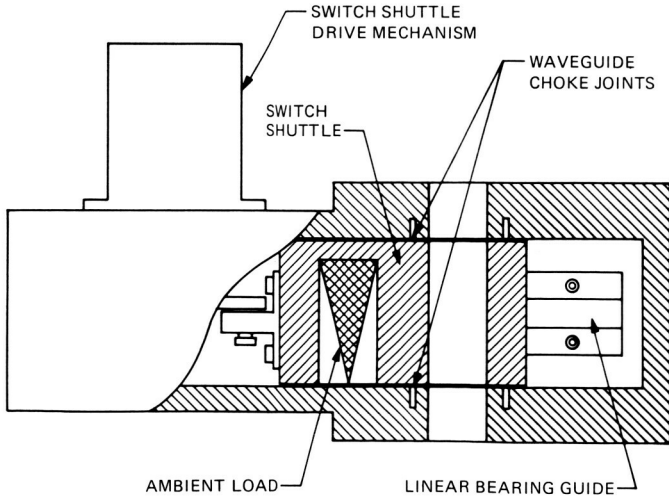

Fig. 4. Cross section of circular waveguide switch

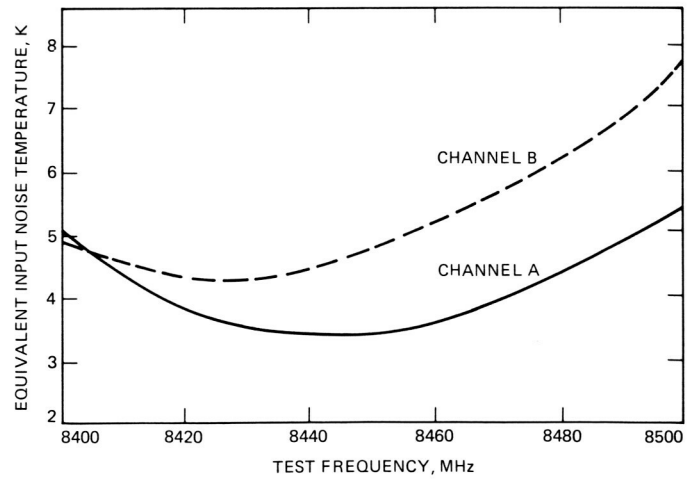

Fig. 6. Equivalent input noise temperature vs frequency curves with TWM tuned to 8.45 GHz