

**N 87 - 24511**

**SLEW MANEUVERS ON THE SCOLE  
LABORATORY FACILITY**

Jeffrey P. Williams  
Spacecraft Control Branch  
NASA Langley Research Center  
Hampton, Va.

## INTRODUCTION

The Spacecraft Control Laboratory Experiment (SCOLE) has been conceived to provide a physical test bed for the investigation of control techniques for large flexible spacecraft. The control problems to be studied are slewing maneuvers and pointing operations. The slew is defined as a minimum time maneuver to bring the antenna line-of-sight (LOS) pointing to within an error limit of the pointing target. The second control objective is to rotate about the line of sight and stabilize about the new attitude while keeping the LOS error within the 0.02 degree error limit. The SCOLE problem is defined as two design challenges. The first challenge is to design control laws for a mathematical model of a large antenna attached to the Space Shuttle by a long flexible mast. The second challenge is to design and implement a control scheme on a laboratory representation of the structure modelled in the first part [1]. Control sensors and actuators are typical of those which the control designer would have to deal with on an actual spacecraft. Computational facilities consist of micro-computer based central processing units with appropriate analog interfaces for implementation of the primary control system, and the attitude estimation algorithm.

This report gives preliminary results of some slewing control experiments which demonstrate the capabilities of the recently completed experimental facility.

- \* EXPERIMENT CONCEIVED TO PROVIDE A COMMON "DESIGN CHALLENGE FOR INTERESTED INVESTIGATORS
- \* SLEWING AND POINTING CONTROL PROBLEM
- \* USES ANTENNA LIKE STRUCTURAL CONFIGURATION AND INERTIAL SENSORS AND ACTUATORS
- \* VARIETY OF SENSOR AND ACTUATOR TYPES
  - Accelerometers, rate sensors, optical position
  - Thrusters, cmg, reaction wheel
- \* MULTI-MICROPROCESSOR BASED COMPUTING
- \* WILL DEMONSTRATE EFFECT OF APPLYING RIGID-BODY CONTROL LAW TO A FLEXIBLE STRUCTURE USING THRUSTERS ONLY

## SLEW MANEUVER ON THE SCOPE

The primary purpose of this paper is to demonstrate the capability of the laboratory facility to fulfill the requirements of the second part of the Design Challenge presented by Taylor and Balakrishnan [1]. That requirement is for an accessible laboratory experiment which will allow the study of slewing maneuver of flexible spacecraft.

A 20 degree single axes minimum-time slew using the reflector mounted thrusters is presented. An ad-hoc control scheme which allows the maneuver to be completed without exciting the 1st bending mode of the mast is also demonstrated. No theoretical analysis is offered to justify the performance of the controller or to generalize the technique to other flexible structures.

- \* PART TWO OF SCOPE DESIGN CHALLENGE (Taylor, Balakrishnan)
- \* SLEW 20 DEGREES USING THRUSTERS
- \* WILL DEMONSTRATE AD-HOC CONTROL LAW TO SLEW WITHOUT EXCITING 1st BENDING MODE
- \* SCOPE LABORATORY FACILITY IS PROVIDED AS A TEST-BED FOR EVALUATION OF CONTROL LAWS FOR LARGE FLEXIBLE STRUCTURES.
- \* IMPLEMENTATION OF A CLASSICAL RIGID BODY BANG-BANG SLEWING CONTROL LAW DEMONSTRATED THAT FLEXIBILITY OF THE SCOPE APPARATUS WILL PRESENT CONTROL CHALLENGES SUFFICIENT FOR IDENTIFYING CONTROL DESIGN METHODOLOGIES WHICH MAY BE APPLIED TO FUTURE LARGE FLEXIBLE SATELLITES
- \* IMPLEMENTATION OF AN AD-HOC CONTROLLER FOR VIBRATION ACCOMMODATION DEMONSTRATED THAT FLEXIBILITY OF THE STRUCTURE CAN BE SUPPRESSED

## SCOLE LABORATORY APPARATUS

The laboratory experiment shown in the figure attempts to implement the definition of the modelling and control design challenge within reasonable limits of the 1g, atmospheric environment. The experimental facility exhibits the essential SCOLE characteristics of a large mass/inertia connected to a small mass/inertia by a flexible beam. Some trades are made in terms of structure, sensors, actuators, and computational capability in order to develop the experiment in a timely and cost effective manner. To this end, the basic structure is made of homogeneous continuous elements connected by welds and mechanical fasteners. The sensors are aircraft quality rate sensors and servo accelerometers. The Shuttle attitude will be determined through a combination of inertial measurements and optical sensing techniques. The Shuttle control moments are provided by a pair of 2-axis control moment gyros (CMG's). Mast mounted control torques can be applied by a pair of two-axis reaction wheels. Reflector based forces are provided by solenoid actuated jets. Reflector mounted torque devices are a trio of high authority reaction wheels.



ORIGINAL PAGE IS  
OF POOR QUALITY



## STRUCTURES

The SCOLE is comprised of three basic structures, the Shuttle, the mast, and the reflector panel. The assembly of these individual components and the global reference frame are shown in the figure.

The Shuttle platform is made from a 13/16 inch steel plate and has overall dimensions of 83.8 by 54.0 inches. Its total weight is 501.7 pounds. The Shuttle's center of mass is located 3.4 inches below the experiment's point of suspension, and 26.8 inches forward of the tail edge.

The mast is 120 inches long. It is made from stainless-steel tubing and weighs 4.48 pounds. One-inch thick manifolds are mounted to the mast at each end.

The reflector panel is hexagonal in shape, made from welded aluminum tubing, and weighs 4.76 pounds. It is located 126.6 inches below the SCOLE's point of suspension. The center of the reflector is located at 12.0 inches in the x direction and 20.8 inches in the y direction from the end of the mast.

### BASIC SCOLE STRUCTURE

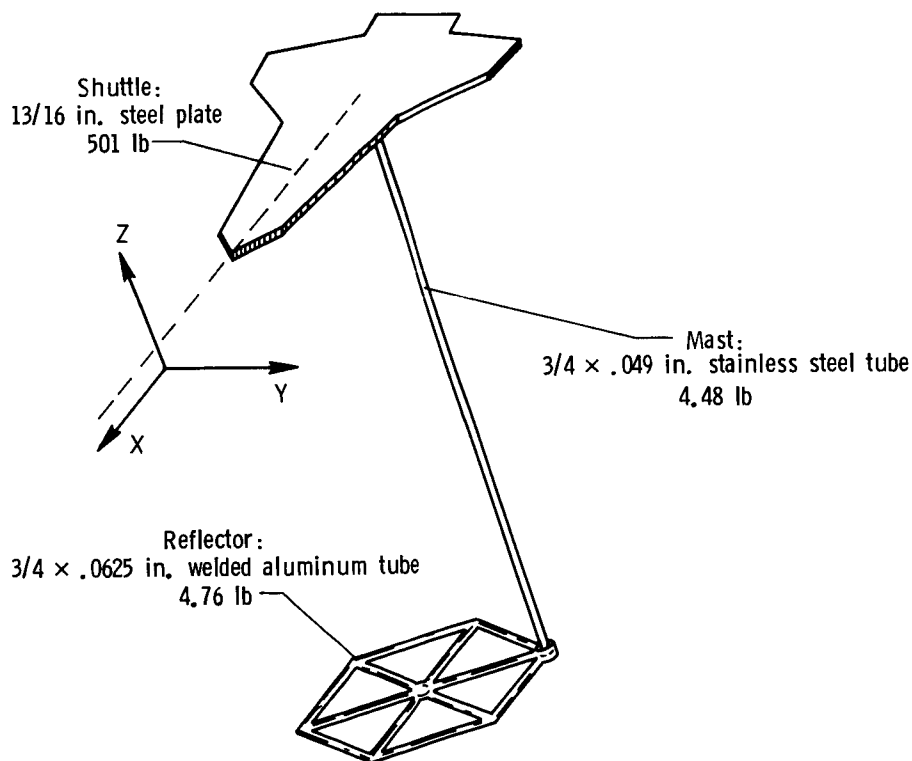

SUSPENSION GIMBAL

ORIGINAL PAGE IS  
OF POOR QUALITY

The complete system is suspended from an eleven-foot cable attached at the system center of gravity via a universal joint. The positive z-axis of the Shuttle is pointed up, thus minimizing the static bending of the antenna mast. The suspension point shown in the figure is a two-degree-of-freedom gimbal for pitch and roll rotations with yaw rotation supplied by the suspension cable. The estimated break-out torque of the gimbal is 0.1 ft-lb. The gimbal is fixed to the Shuttle plate, and the system center-of-gravity is made to coincide with the center-of-rotation by means of an adjustable counter balance system.

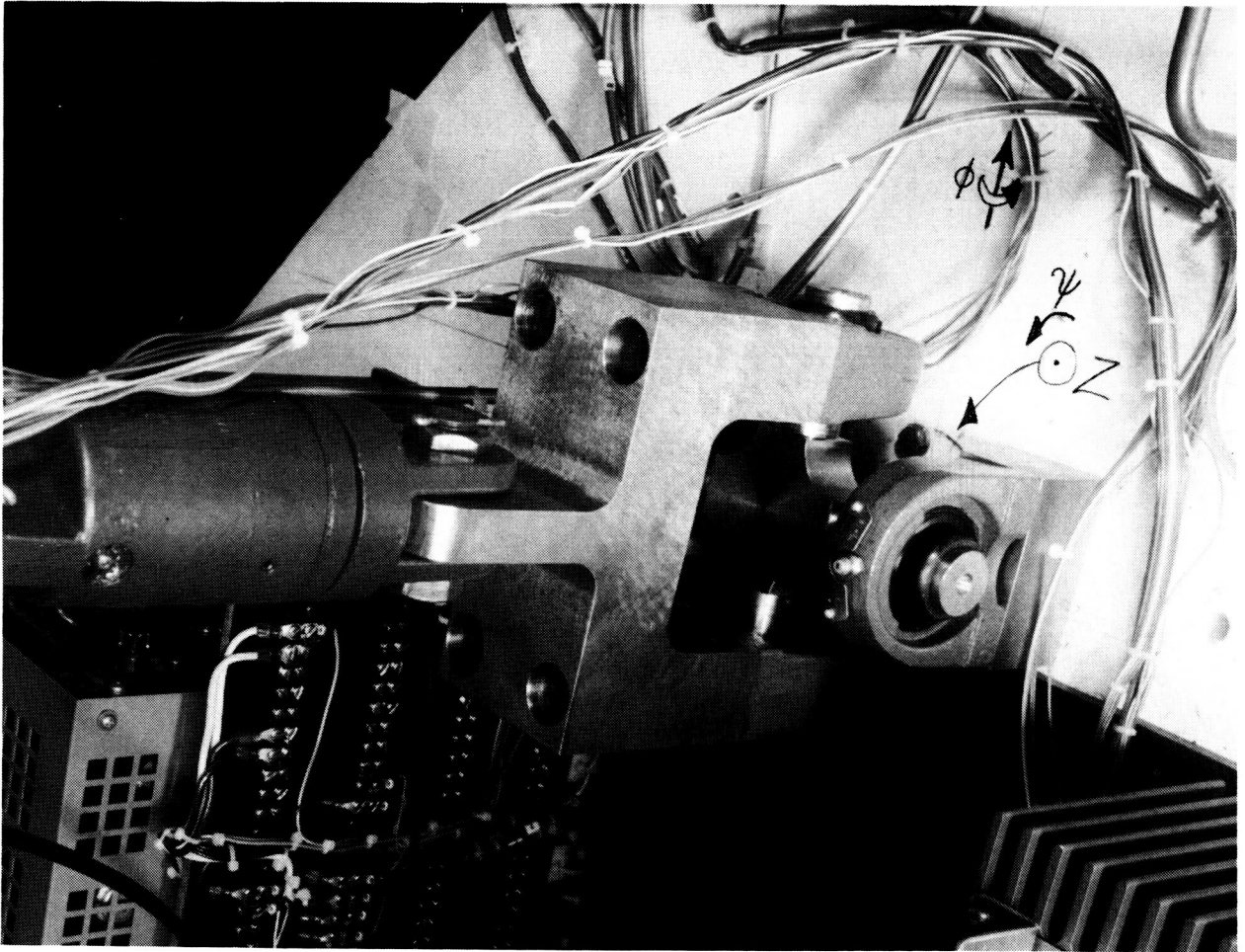

## SLEW CONTROL LAW

The slewing of a rigid body spacecraft has long been accomplished with a simple on-off control algorithm which can be derived by examining the phase-plane solution of the simple forced-double-integrator dynamical system. Such a system will describe a parabolic path in the phase plane. The particular path is a function of the initial conditions and the applied torque. If one formulates the final condition problem by specifying zero attitude and zero attitude rate at the final time, backward solution of the equations of motion shows that the approach to the origin must follow the skew-symmetric parabolic curves shown in the figure. These lines will be called the control switching curves. For a given initial condition, the starting command to drive states of the body toward one of the switching curves may be determined by inspection. When the states intersect one of the curves, the control command will change sign and the states will then be driven to zero. This algorithm is shown to be minimum-time by Bryson and Ho in reference 2. If the effectiveness of the torquers is mis-estimated, the controller will still converge to zero, but more than one switch will be required. Also, to allow for practical implementation, a dead-band must be included so that the control command may be set to zero when sufficient attitude performance is achieved.

Such a control law is implemented on the SCOLE by using the reflector mounted thrusters for the control torque. The Shuttle rate sensor and accelerometers are used to estimate attitude rate and attitude by ignoring pendulum motion of the suspension system. The cold air thrusters on SCOLE have about 0.2 lb force output and are approximately 10 ft from the center of rotation. Their rise time is about 0.032 seconds.

- \* FOR A SIMPLE RIGID BODY SLEW ABOUT ONE AXIS,

$$I \ddot{\Theta} = tu$$

- \* THE MINIMUM TIME MANEUVER IS GIVEN BY (Bryson & Ho):

$$u = +1 \quad \begin{array}{l} \text{if } \dot{\Theta}^2 \text{sign}(\dot{\Theta}) < -2 t/I \Theta \text{ or} \\ \text{if } \dot{\Theta}^2 \text{sign}(\dot{\Theta}) = -2 t/I \Theta \text{ and } \Theta > 0 \end{array}$$

$$u = -1 \quad \begin{array}{l} \text{if } \dot{\Theta}^2 \text{sign}(\dot{\Theta}) > -2 t/I \Theta \text{ or} \\ \text{if } \dot{\Theta}^2 \text{sign}(\dot{\Theta}) = -2 t/I \Theta \text{ and } \Theta < 0 \end{array}$$

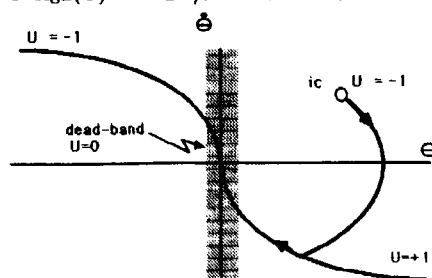

- \* FOR IMPLEMENTATION:

$\dot{\Theta}$  derived from rate sensor

$\Theta$  derived from accelerometers by ignoring pendulum effects

## DAMPING CONTROL LAW

For a cantilevered end condition, that is to say, no rigid-body motion, a vibration suppression control law which uses the reflector mounted rate sensor and the thrusters may be derived. The control law is simply to command thrust opposite the sign of the velocity component parallel to thrust axes at the point of attachment of the thrusters. This control will cause a linear decay of the controllable vibration modes.

For implementation on the SCOLE, the velocity of the center of the reflector (attachment point of the thrusters) is estimated by calculating the cross product:

$$\underline{v} = \underline{r} \times \underline{w}$$

where  $\underline{r}$  is the position vector of the thrusters with respect to the rate sensor mounted on the corner of the reflector and  $\underline{w}$  is the output vector of the rate sensor.

Here again, a dead-band is required so that the thrusters will turn off when the state origin is reached.

- \* SUPPRESS BENDING MODE VIBRATIONS OF MAST/REFLECTOR
- \* FOR CANTILEVERED END CONDITIONS SIMPLE COLLOCATED FEED-BACK WILL SUFFICE:

$$U = - \text{sign} (\text{velocity of thrusters})$$

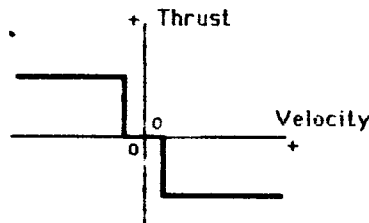

- \* FOR IMPLEMENTATION, VELOCITY OF THRUSTERS IS DERIVED FROM REFLECTOR MOUNTED ANGULAR RATE SENSOR BY CALCULATING:

$$\underline{V} = \underline{r} \times \underline{w}$$

where  $\underline{V}$  is the thruster velocity,  $\underline{r}$  is the position vector of the thrusters w.r.t. the angular rate sensor, and  $\underline{w}$  is the output angular rate sensor.

## AD-HOC SLEW CONTROLLER

Observation of the structural configuration indicates that the first mode of motion for the system will be a bending mode which will have the Shuttle and the reflector bending toward each other. A command to slew would tend to excite this mode. To suppress the flexible motion would require a thruster command which is contrary to the desired attitude motion. To resolve this dilemma, use is made of the position dead-band for the bang-bang slew control law and the rate dead-band of the vibration suppression control law. By combining the thrust commands for the two controllers, a semi-consistent control command can be determined. A semi-consistent command is one which has the sign and magnitude of at least one of the individual commands. To determine the semi-consistent command, one must first recognize that the thruster can have one of three states: -1, 0, or +1. If the two commands have opposite signs, they are inconsistent and the only control choice is to command zero thrust. If the signs are the same, or if one command is zero and one is non-zero, then the command to the thrusters should be the sign of the sum of the individual commands. Admittedly, this technique does not account for more than one flexible mode, but recall that the stated purpose of the paper is to demonstrate the capability of the laboratory facility, not to develop new control theory.

- \* DETERMINE CONTROL COMMANDS FOR BOTH CONTROL LAWS SIMULTANEOUSLY

- IF COMMANDS CONFLICT ( ARE OF OPPOSITE SIGN ),  
TURN THRUSTERS OFF

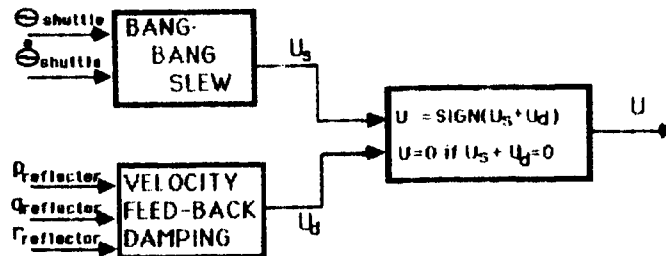

- \* NO MODAL DECOUPLING ATTEMPTED
  - THAT IS TO SAY, OUTPUTS OF SENSOR ARE USED DIRECTLY
- \* MUST RECOGNIZE THAT NO THEORY IS PRESENTED TO PREDICT PERFORMANCE OR GENERALIZE THIS TECHNIQUE TO OTHER FLEXIBLE STRUCTURES

## SENSORS

The sensors for the experiment consist of three servo-accelerometers and two, three-axis rotational rate sensing units. The power supplies for these sensors are mounted on the Shuttle plate to minimize the number of large gauge wires which must cross the universal joint suspension point. Only a single 115 VAC cable and thirty-three signal wires cross the universal joint. The wires for the sensors are routed on the Shuttle and along the mast.

### SHUTTLE MOUNTED ACCELEROMETERS

The Shuttle-mounted accelerometers shown in the figure sense the x,y, and z accelerations of the Shuttle and gravity. The output of the x and y accelerometers are used to determine attitude angle by neglecting pendulum effects of the suspension system. These sensors are distributed away from the suspension point to aid inertial attitude estimation. The accelerometers have a frequency response which is nearly flat up to 350 Hz. Linearity is within .17% of the full-scale output.

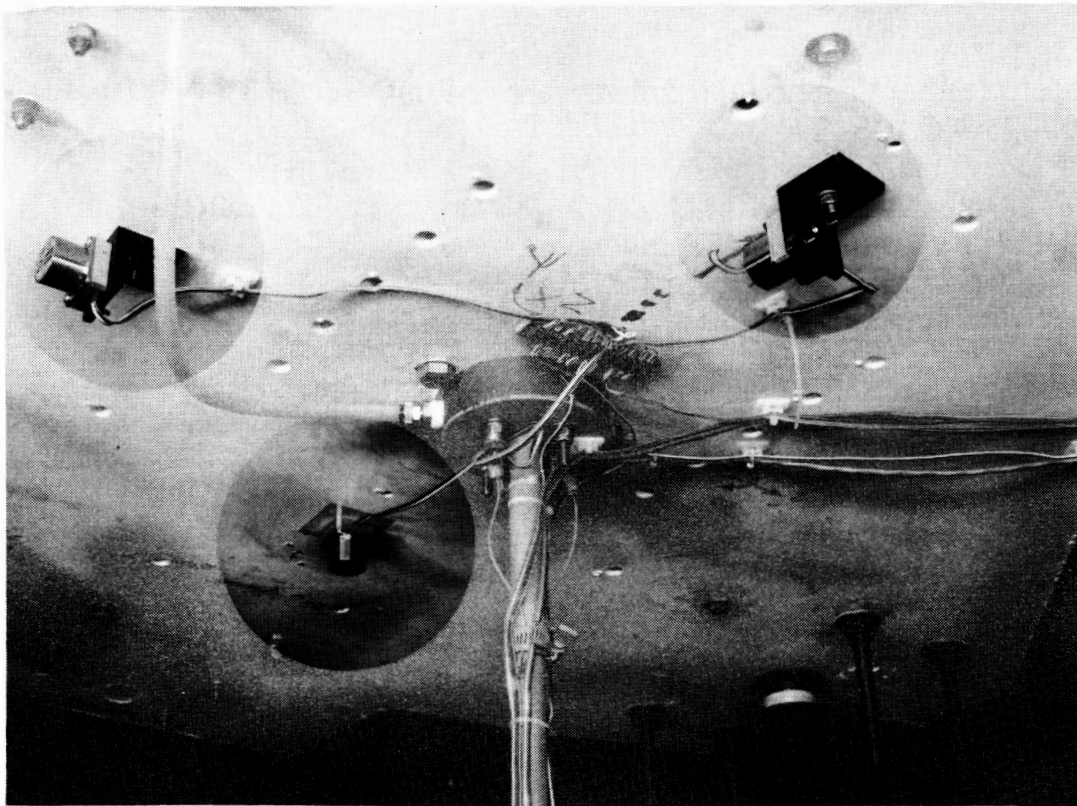

ORIGINAL PAGE IS  
OF POOR QUALITY

REFLECTOR-MOUNTED CONTROL DEVICES

ORIGINAL PAGE IS  
OF POOR QUALITY

The reflector-mounted rate sensor package, shown in the extreme left of the figure, senses three axis angular rates at the reflector end of the mast. This information is used for the vibration suppression control law.

The control forces on the reflector are provided by solenoid actuated cold gas jets. The thrusters are mounted in the center of the reflector and act in the x-y plane. The jets are supplied by a compressed air tank mounted on the Shuttle. The pressurized air travels through the mast to the solenoid manifold which gates the air flow between the regulated supply tank and the thrusters. Thrust is initiated by opening the solenoid with a discrete command.

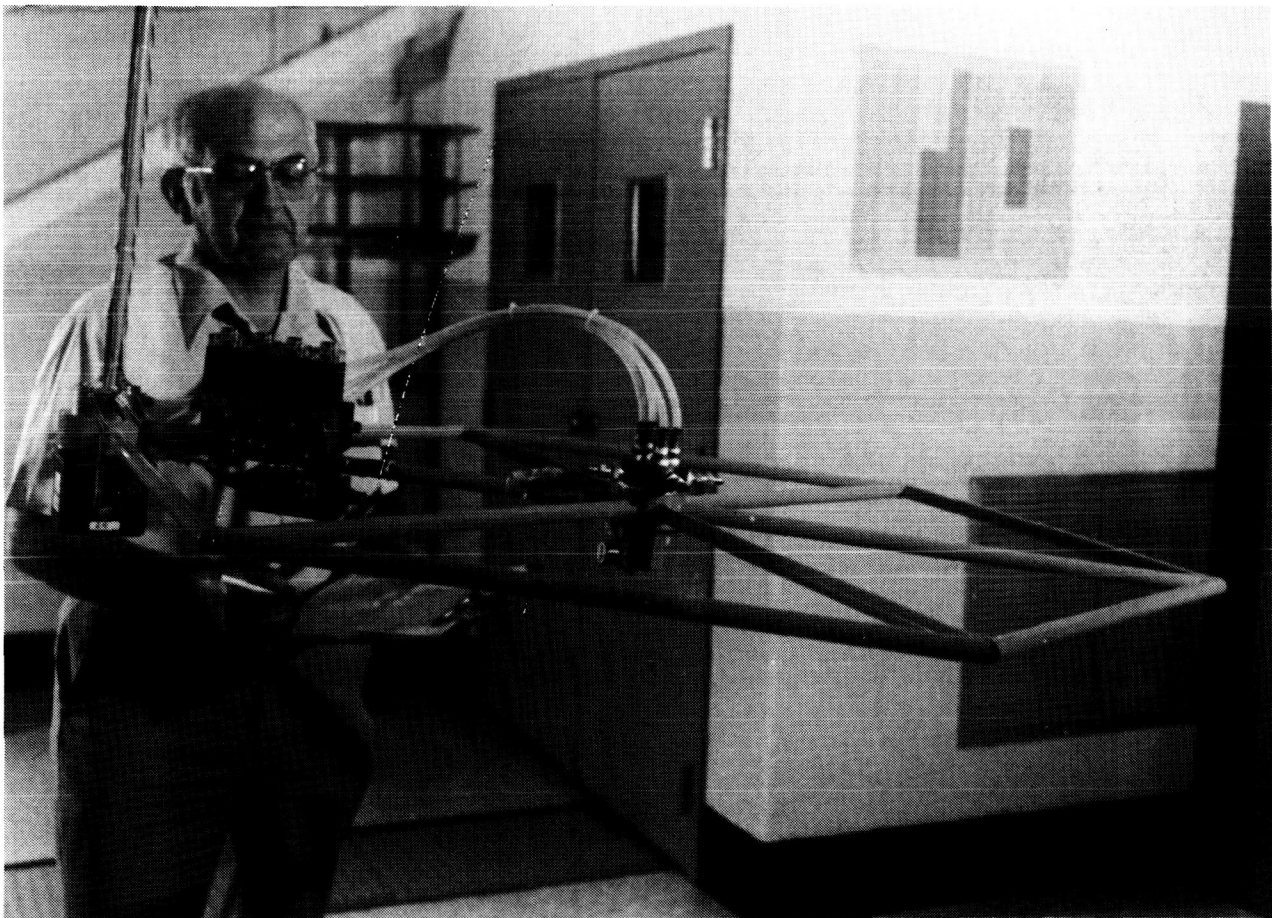



## SHUTTLE RATE SENSORS

The rotational rate sensors are three axis aircraft quality instruments. The frequency response is approximately flat to 1 Hz and -6 db at 10 Hz. Linearity is about 0.6% full scale. The range is 60 deg/sec for the yaw and pitch axes and 360 deg/sec for roll. The threshold is 0.01 deg/sec.

The Shuttle-mounted rate sensor package shown in the figure, senses three axis rigid body angular rates of the Shuttle plate. These data are used for the slewing control law.



ORIGINAL PAGE IS  
OF POOR QUALITY



## COMPUTER SYSTEM

The main computer for control law implementation will be a micro-computer based on the Motorola M68000 microprocessor. The computer has 2.0 Mbyte of random access memory and a 40 M-byte hard disk. The operating system is based on UNIX with C, Fortran and Pascal compilers available for applications programming. The computer has 12 serial ports and one parallel port. Terminals are connected on two of the ports and an answer-only modem is attached to another. One port is used for an originate only modem. A line printer is attached to another port.

Analog interfaces consist of a four-bit output-only discrete channel, eight digital-to-analog converters and sixty-four analog-to-digital converters. All converters are 12 bit devices with a range of +/-10v.

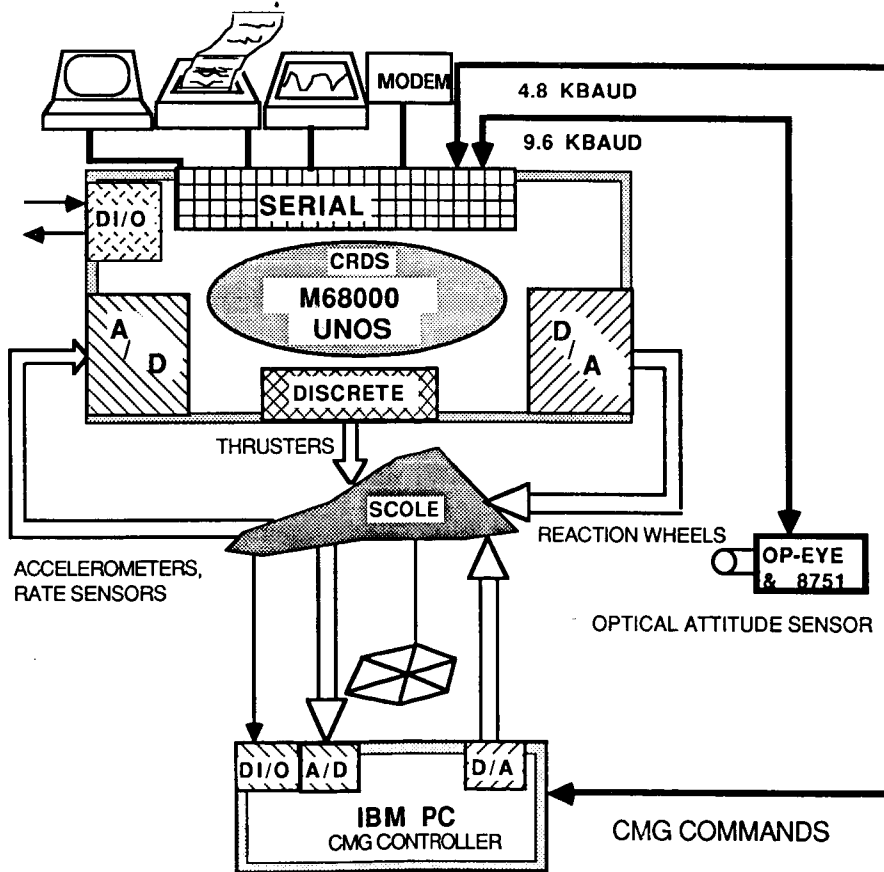

## EXPERIMENTAL RESULTS

The effect of applying the rigid-body bang-bang slewing control law to a flexible structure without taking that flexibility into account is demonstrated in the top four time histories. The data presented are, from top to bottom: the Shuttle roll attitude estimate, the Shuttle roll rate estimate, the reflector roll rate measurement, and the thruster command perpendicular to the roll axis. The control law is demonstrated by applying an external torque during the first five seconds with the control disabled. After approximately 20 degrees of attitude error is built up, the control was enabled. The reduction of the attitude error and first switch of the thrust command proceeds essentially as expected for a simple double integrator plant. The oscillation of the attitude during the period from twelve to twenty-two seconds is due to an under estimate of the control effectiveness of the thrusters. Note however that the attitude error continues to decrease. The structural dynamics and control problem addressed by the SCOLE Design Challenge are evident in the oscillation of the Shuttle and reflector roll rates. After the attitude error has become very small at about nineteen seconds it is apparent that the flexible mode is completely unstable and would eventually lead to structural failure.

The effectiveness of the ad-hoc controller in accomplishing the slew without exciting the flexible motion is shown in the bottom four time histories. The same variables are plotted here as above. In this case, the consistency comparison between the slew command and the vibration suppression command allows the slew command to take effect only during short bursts which usually last only one sample period. These pulses are sufficient to drive the attitude error to zero, but the maneuver takes about six seconds longer than the slew only control law. Note however, that the flexible motion is not appreciably excited in this case. Also, because the attitude rates remain relatively small, the attitude error remains relatively low. A final special circumstance in this demonstration must be recognized - that is that the initial condition of the plant had essentially zero excitation of the flexible mode. If it had been excited prior to activation of the control, it is possible that the slew would not have been accomplished.

## RIGID BODY BANG-BANG SLEW ONLY

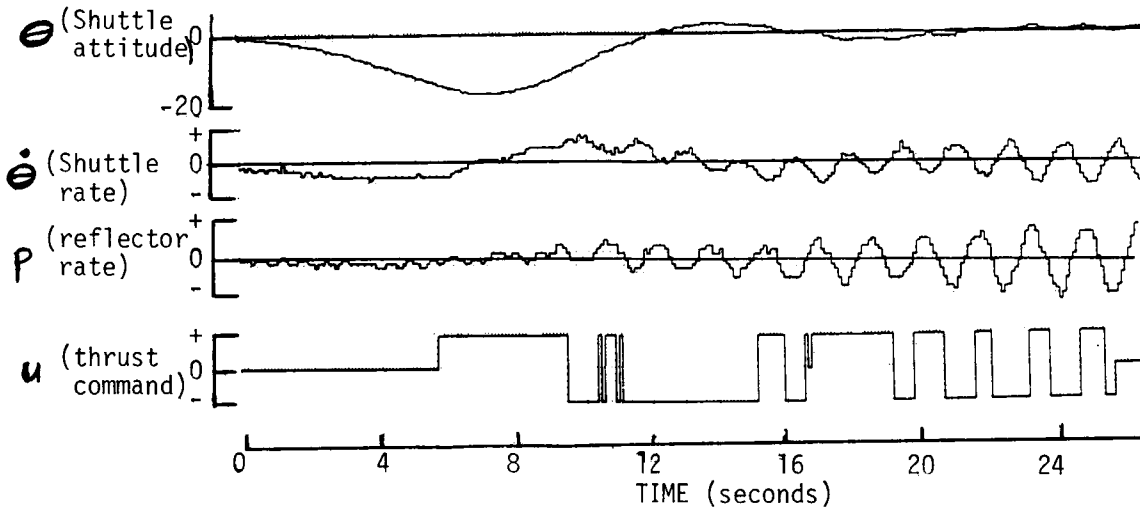

## BANG-BANG SLEW & VIBRATION SUPPRESSION

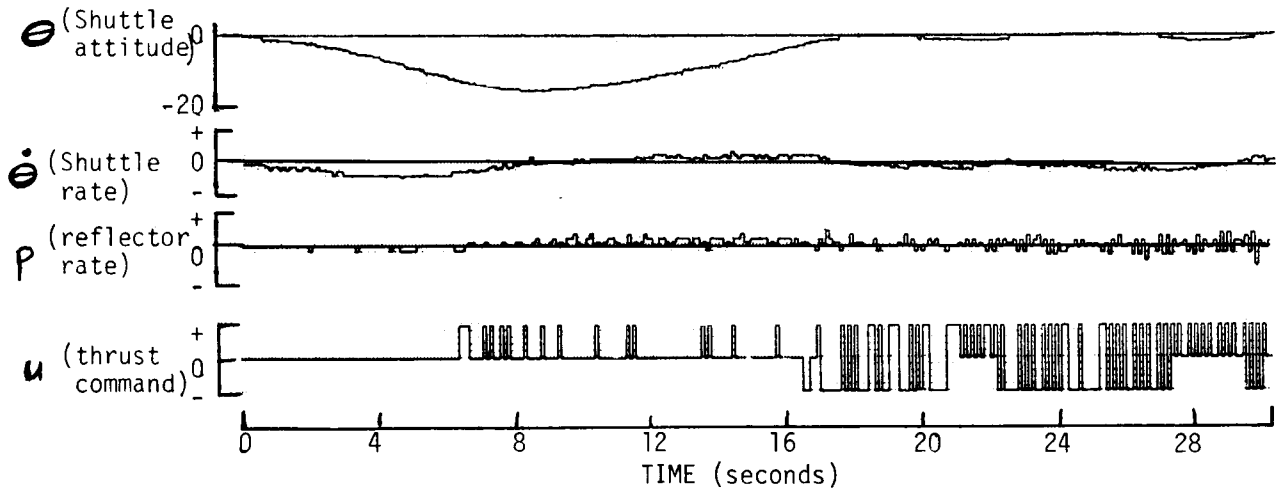

## CONCLUSIONS

The SCOLE laboratory facility has been constructed to provide a test-bed for the testing and evaluation of control laws for large flexible structures. Implementation of a classical rigid body bang-bang slewing control law has demonstrated that the combination of flexibility and control authority present on the SCOLE apparatus will present control challenges sufficient for identifying control design methodologies which may be applied to future large flexible satellites.

The implementation of an ad-hoc controller for vibration accommodation demonstrated that flexible motion of the structure can be suppressed.

## REFERENCES

1. Taylor, L.W., Jr., and Balakrishnan, A. V.: A Laboratory Experiment Used to Evaluate Control Laws for Flexible Spacecraft...NASA/IEEE Design Challenge, Proceedings of the Fourth VPI&SU/AIAA Symposium on Dynamics and Control of Large Structures, June 1983, pp. 311-318.
2. Bryson, A.E., Jr., and Ho, Y.C.: Applied Optimal Control, Optimization, Estimation, and Control, John Wiley & Sons, N.Y., 1975.