

11-53 CR

85459

P-12

Operator Function Modeling:
An Approach to Cognitive Task Analysis in
Supervisory Control Systems

Annual Report

(NASA-CR-181180) OPERATOR FUNCTION MODELING: AN APPROACH TO COGNITIVE TASK ANALYSIS IN SUPERVISORY CONTROL SYSTEMS Annual Report (Georgia Inst. of Tech.) 12 p Avail: NTIS HC A01/MF A01 CSCL 05I G3/53 N87-25761 Unclas 0085459

Christine M. Mitchell
Center for Man-Machine Systems Research
School of Industrial & Systems Engineering
Georgia Institute of Technology
Atlanta, Georgia

August 31, 1987

**

The NASA-Ames Research Center project is comprised of three related activities (figure 1 is an overview of this research). The first is a study of the use and development of models of operators in complex, automated space systems. A review of the literature was conducted and several papers are in-progress or completed that examine the use and structure of such models to design and evaluate operator workstations and to aid operator decision making [4, 5, 6]. The operator function model (OFM) methodology was extended to represent cognitive as well as manual operator activities [1]. Thus, the heterarchic/hierarchic network of finite-state automata has its lowest level and its model output both physical and cognitive actions. This enhancement extends the OFM structure to provide a tool for cognitive task analysis. Figure 2 depicts an example of this model applied to a NASA satellite control system. [1] is a detailed explanation of the OFM applied to a NASA ground control system.

The second activity is the on-going development of OFMdraw (figure 3). OFMdraw is a software tool that facilitates the construction of an OFM. OFMdraw is implemented on a Macintosh Plus in Expertelligence and Exper's Interface Builder. Currently, OFMdraw can be used to construct a heterarchic network

**

Note: Some of this research has been conducted in conjunction with research sponsored by NASA-Goddard Space Flight Center.

of nodes and arcs. The nodes can be labeled; ability to label arcs is still in-progress. OFMdraw has some hierarchic capabilities, i.e., the user can 'go down' from a node on the current level to view the decomposition at the level below. The user can also 'go up' to the heterarchic level above the current level, when one exists. The ability to label arcs and represent interactions among different levels in the hierarchies is still under development. The ability to print and save an OFM model is also in-progress. Once these tasks are completed, OFMdraw will be enhanced to make it complement more easily the definition and implementation of an OFMspert for a system.

OFMspert is the third activity in this research and it received the majority of effort this year (figure 4). OFMspert has two purposes: 1) it is a methodological extension of the structure (network of finite-state automata) of the original OFM to encompass explicitly the domain-specific information in order to function as a self-contained, on-line model of the human operator capable of carrying out the control tasks (i.e., a special kind of expert system that understands and acts in ways analogous to those of a human decision maker); and 2) OFMspert is intended to act as an operator's associate, an expert system that can offer advice and dynamically assume responsibilities for portions of the supervisory control task in automated space systems. The project proceeded as follows [2, 3, 5]. First, an OFMspert architecture was defined. The crux of the system is the use of the blackboard method of problem solving to construct and maintain an on-line representation of operator intentions, called

ACTIN (actions interpreter). ACTIN uses the OFM to define operator goals, plans, and tasks. Given a normative representation of current operator state, ACTIN interprets operator actions (either system commands or information requests). OFMspert is currently implemented in Smalltalk/V and runs on a 12MHz PC AT. It runs in real time connected to the GT-MSOCC (Georgia Tech Multisatellite Operations Control Center) simulation that runs on a Vax. Preliminary validation shows that OFMspert intent inferencing capabilities are quite good. Future validation is expected to suggest areas that need improvement, e.g., ability of OFMspert to 'understand' operator errors. Future work with OFMspert includes implementation of OFMspert control capability, examination of user interaction with OFMspert (i.e., how to design effectively a control team consisting of a human operator and OFMspert), and the definition of direct manipulation interfaces that allow operator intent inferencing by OFMspert.

Operator Function Model (OFM)

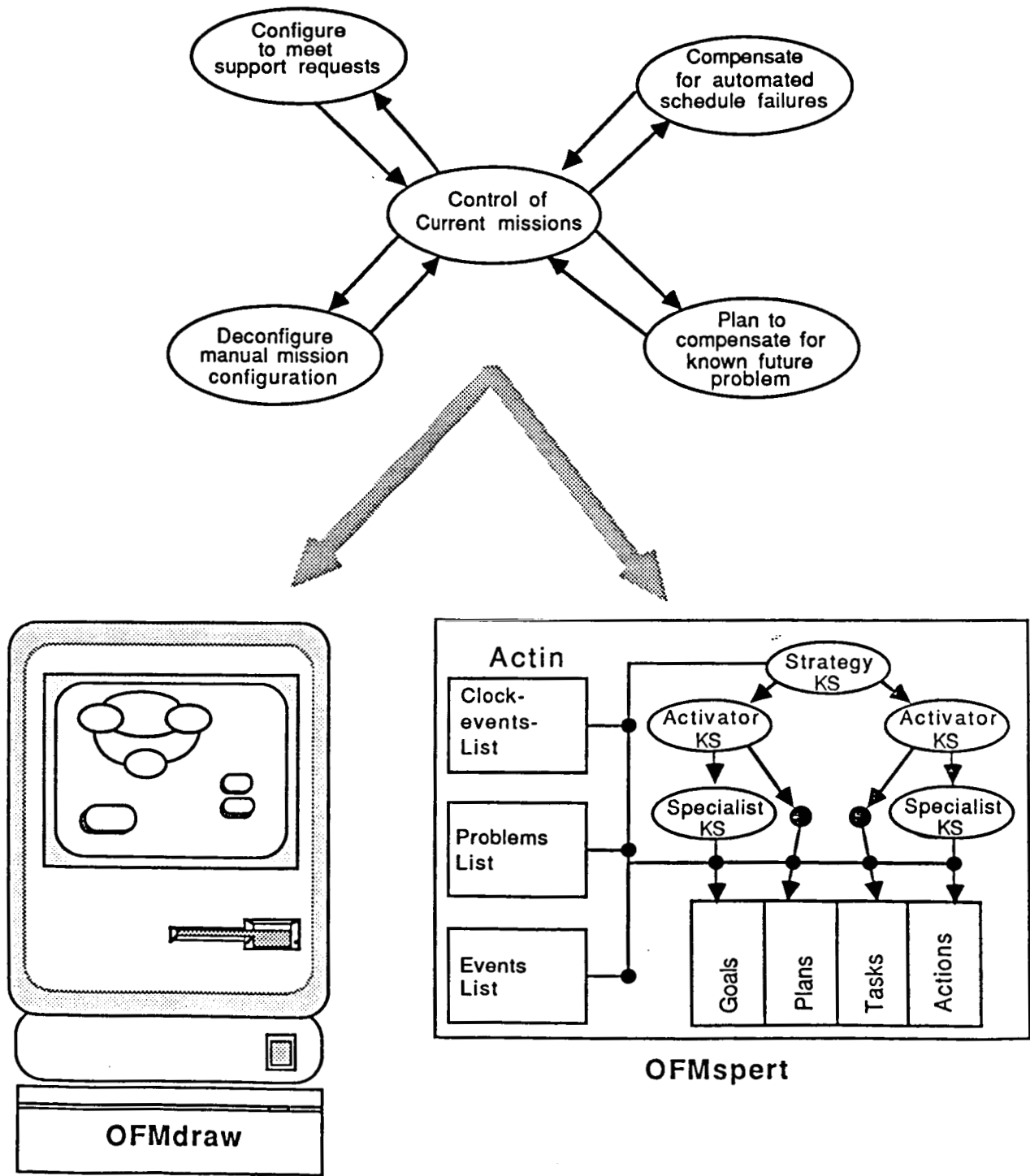

Christine M. Mitchell
 Georgia Institute of Technology (7/87)

Figure 1

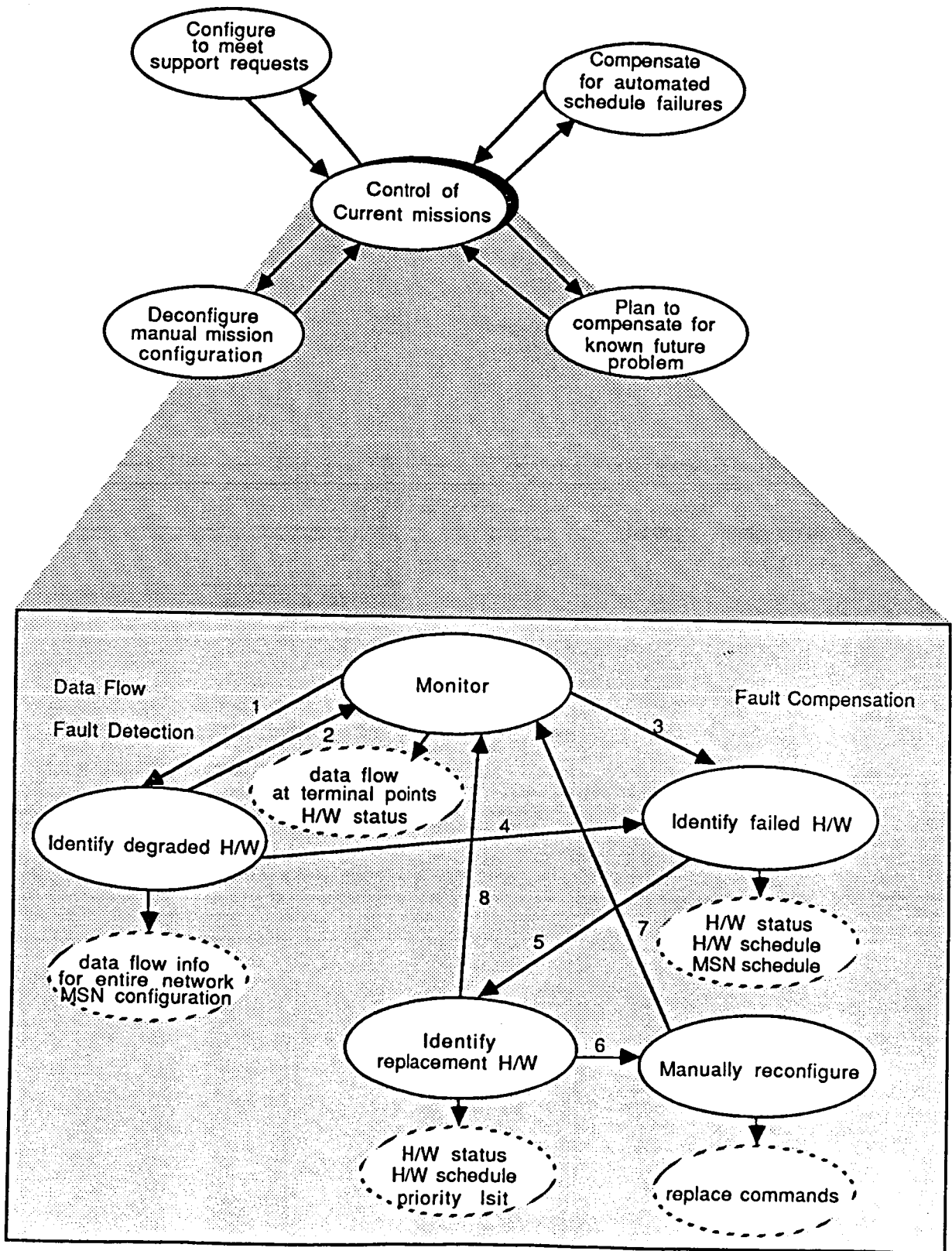

OFM

Figure 2

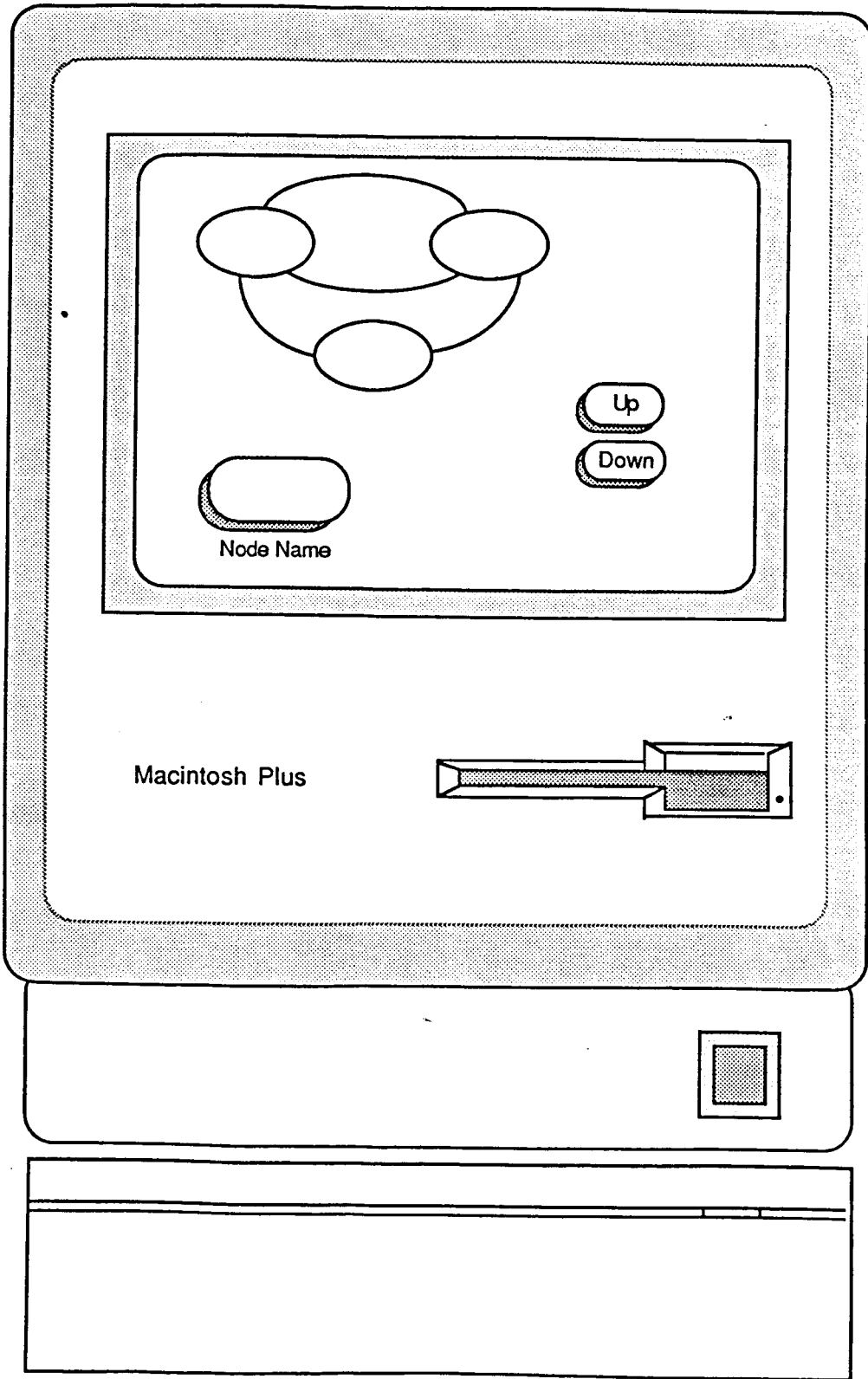

OFMdraw

Figure 3

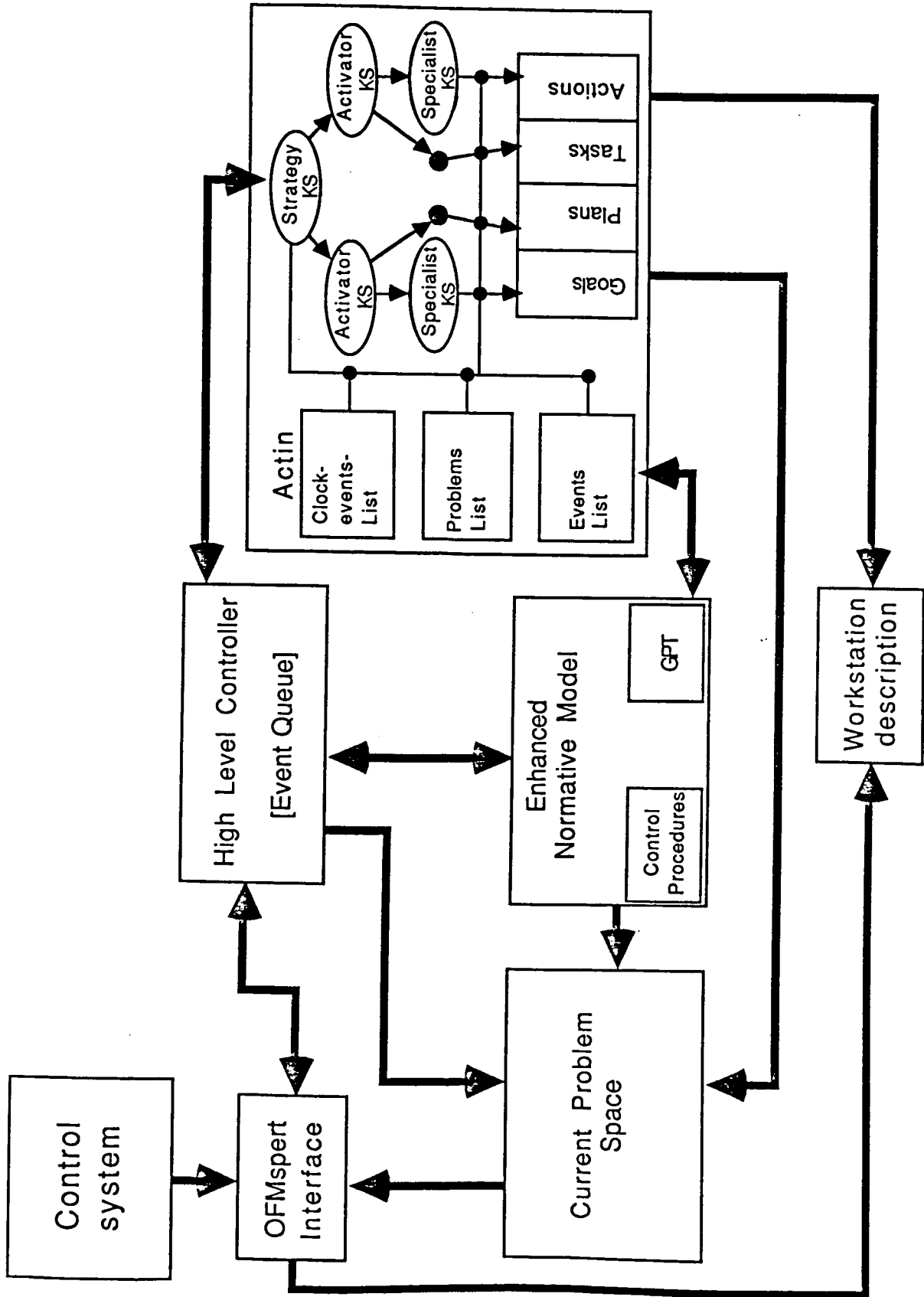

OFMspert Architecture

Figure 4

Appendix A

Publications Related to the OFM Research

Publications Related to the OFM Research

1. GT-MSOCC: A Research Domain for Modeling Human-Computer Interaction and Aiding Decision Making in Supervisory Control Systems, IEEE Trans. Systems, Man, & Cyber., July/August. 1987, to appear.
2. With K. S. Rubin & P. M. Jones, OFMspert: An Operator Function Model Expert System, Proceedings of the 4th Mexican National Artificial Intelligence Conference, Puebla, Mexico, March 1987.
3. With K.S. Rubin & P. M. Jones, OFMspert: An Application of a Blackboard Architecture to Infer Operator Intentions in Real Time Decision Making, IEEE Trans. Systems, Man, & Cyber., submitted to a special issue, .
4. With P.M. Jones, Operator Modeling: Conceptual Distinctions and an Expert System Application, Proceedings of the Fourth Mid-Central Ergonomics/Human Factors Conference, Champaign, Il., July, 1987, to appear.
5. With P. M. Jones & K. S. Rubin, Using a Blackboard Architecture for Dynamic Intent Inferencing, Proceedings of the IEEE Conference on Systems, Man and Cybernetics, Washington, D.C., October, 1987, to appear.
6. With P.M. Jones, Operator Modeling: Conceptual and Methodological Distinctions, Proceedings of the 31st Annual Meeting of the Human Factors Society, New York, October 1987, to appear.

Note: Several technical reports and masters theses related to this work should appear in the next year. In addition, a doctoral dissertation examining the use of direct manipulation interfaces that interact with an operator's associate for supervisory control of automated space systems is in the proposal development stage.