

N 87-26004

COMPUTATIONAL FLUID DYNAMICS - TRANSITION TO DESIGN APPLICATIONS

R. G. Bradley, I. C. Bateley and G. A. Howell
General Dynamics Corporation

INTRODUCTION

The development of aerospace vehicles, over the years, has been an evolutionary process in which engineering progress in the aerospace community was based, generally, on prior experience and databases obtained through wind tunnel and flight testing. Advances in the fundamental understanding of flow physics, wind tunnel and flight test capability, and new mathematical insights into the governing flow equations have been translated into improved air vehicle design. Two notable examples of this evolutionary process that resulted in significant improvements to air vehicles are the area rule and the supercritical wing technology. These examples evolved from a combination of wind tunnel experimentation and analytical advances. The analytical advances include the ability to obtain solutions to the appropriate supersonic and transonic flow equations in simplified form. The modern day field of Computational Fluid Dynamics (CFD) is a continuation of this growth in analytical capability and the digital mathematics needed to solve the more rigorous form of the flow equations.

The explosion in computer technology over the past two decades coupled with the expansive effort in the development of CFD has led to the realization of a dynamic jump in the capability to understand and to apply the governing physics for fluid flow. This capability is even now being realized in the application of CFD to critical design problems involving the solution of complicated flowfields. Industry is now aware that solving a flowfield to reveal the intricate details offers a tremendous potential to understand and improve designs.

This paper presents some of the technical and managerial challenges that result from rapidly developing CFD capabilities, some of the steps being taken by the Fort Worth Division of General Dynamics to meet these challenges, and some of the specific areas of application for high performance air vehicles. One of the primary issues for industry is the effective integration of CFD capability into the design process. What follows is written from this point of view.

CODE DEVELOPMENT AND MATURATION

Phenomenal progress in CFD has been made over the last decade, but a significant task still remains before the maturation of CFD is realized. The ultimate goal is to have fully mature codes that are (1) fully validated by comparison with detailed experimental data, (2) user

friendly, and (3) readily available for complex design applications.

A recent National Research Council study on CFD, Current Capabilities and Future Directions (Reference 1), gives a survey of the current capabilities in CFD and presents some of the areas requiring further effort. It presents a five-step developmental cycle typical for CFD codes, which is illustrated in Figure 1. NASA, the government labs, and industry have already done a great deal of work toward accomplishing many of these steps. For design cases in which the flow environment is not too severe, such as transports, the industry is applying CFD directly into the design cycle. On the other hand, the CFD capability for more complex designs, such as tactical aircraft, has not progressed as far because the flowfields are dominated by flow separations and vortex interactions.

Codes must be validated and/or calibrated before they can be used with confidence. Validation involves detailed flowfield comparisons with experimental data to verify the code's ability to accurately model the critical physics of the flow. This requires close coordination between the code developer and the experimentalist to insure that the accuracy and limitations of the experiments, as well as those of the numerical algorithms and grid densities, are understood and taken into account. Through validation, one assures that the numerical physics of the code give a true representation of the flow physics being modeled.

It is important to note that CFD codes can often be used in analyses and design applications long before the

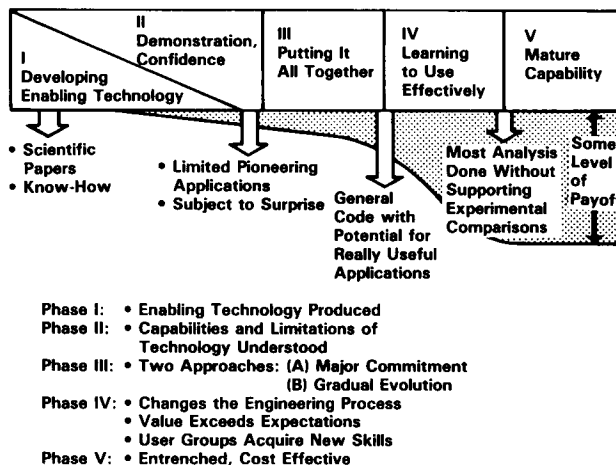

3213-1

Copyright © 1987 by General Dynamics Corporation.
All rights reserved.

Figure 1. The CFD Development Cycle

codes are considered to be mature in the sense of Figure 1. Engineers have always been able to use less than perfect tools coupled with experience and calibration to known physical quantities to provide design guidance. Calibration and validation should not be confused. Calibration provides an error band or correction factor to enhance the ability of a particular code to predict specific parameters that are important to the design objectives for a particular design without verifying that all other features of the flow are modeled accurately. For example one might calibrate a code's ability to predict shock location and lift and moment on a wing without any assurance that the flowfield off the surface and the wake behind the wing are properly modeled. Or, one may calibrate a code's ability to compute gross pressure loss through a supersonic inlet-duct combination without concern for the distortion distribution at the compressor face. Although the use of calibrated CFD solutions is dangerous because of the subtle viscous interactions that are extremely sensitive to geometry and flowfield, skilled engineers can often obtain useful design information and guidance from relatively immature codes.

NASA has pioneered the development of CFD capability with its advanced computer centers and highly competent cadre of CFD algorithm developers. The ability to solve more complex equations efficiently, riding upon the wave of developments in computer hardware technology, has been revolutionary. More recently, emphasis has been placed on solving the governing equations for complex geometries, including full aircraft configurations. In general, at this point in time it is possible to solve complex flow equations for simple geometries or to solve simplified flow equations for complex geometries, but it is not possible to do both.

Major areas of uncertainty still remain, such as the development of grid systems for complex configurations so that they reflect the proper scales to model both the viscous and basically nonviscous flow regions. Also, in the proper modeling of physical parameters such as turbulence, heat transfer mechanisms, combustion kinetics, etc., much remains to be learned. Progress is being made in both of these areas, but there is much work to be done before the full capability of CFD is realized.

DESIGN REQUIREMENTS

If one considers CFD from the advanced design manager's point of view, one obtains a perspective completely different from that of the code developer. Recall that the aerospace designer is responsible for defining the best configuration to meet performance specifications in the shortest time and at the lowest cost. He has traditionally relied upon extensive test results to guide his design decisions and to supply the flight envelope database needed for comprehensive performance calculations. Admittedly, wind tunnel test data have many limitations, but designers have years of experience to help in understanding those limitations. Today's dilemma for the designer of high performance aircraft is illustrated in Figure 2.

The potential and promise of CFD is well known. For the first time in the history of aeronautics, the designer actually has the opportunity to generate solutions for complex flowfields and to examine the detailed microscopic features of the flow that influence a design. The challenge, now, is to provide usable, believable, cost and schedule effective codes for design application and to integrate these codes into the designer's toolset. This is

both a technical and a management challenge. A responsible designer, however, raises legitimate questions about the benefits of CFD in helping him to meet his requirements as shown in Figure 2.

Capability - The ability of the codes to model flowfields about complex geometries over a wide range of flow conditions such as Mach number, Reynolds number, angles of attack and yaw and to produce results in a form that are meaningful to the designer.

Turnaround - The time required to set up geometries, grid meshes, and obtain converged solutions.

Availability - The level of expertise required to generate the flowfield solutions (e.g., can a designer run the code or does it require a CFD specialist).

Cost - The cost effectiveness of a CFD approach relative to other options.

Confidence - The dependability of the codes to give accurate solutions over the range of design variables.

These concerns are a legitimate focus for developers of CFD codes and for engineers who are integrating the capability into the design process. While all of the concerns are vitally important, confidence is perhaps most critical at the current time. This is especially true for the tactical aircraft designer since the CFD experience level is generally low among designers, and the flowfields of tactical aircraft are most complicated. CFD code developers can raise the confidence level through careful validation of the codes being developed.

MANAGEMENT ISSUES

Becoming of age, CFD capability indeed holds the glowing promise of permitting a designer of aerospace vehicles to literally step inside a flowfield and observe the details of the flow through the use of graphics. While this exciting possibility has captured the imagination of the engineer, it has created a new set of challenges for management. As in the case of any evolving technological capability, the manager is faced with the problem of how to integrate it into his organization. To whom will the new capability be assigned for manage-

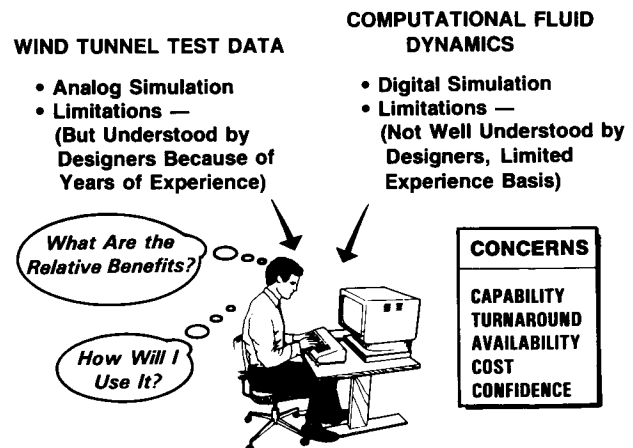

Figure 2 The Designers' Dilemma

ment purposes? Who will be responsible for meshing it into the design process? What procedures will be followed to ensure that only mature and/or calibrated data are used, and what measure of confidence will be placed in the CFD results for design application? These issues present the manager with a situation that is somewhat different from the customary work environment. The following paragraphs outline a management approach adopted by the Fort Worth Division of General Dynamics.

Role of CFD

The general philosophy has been to build a strong, applications-oriented CFD capability that draws heavily upon the expert development work of NASA and other government-sponsored research in labs, universities and industry. The available capability is adopted and/or modified for efficient use in design and is calibrated and/or validated for specific applications. Basic code and grid generation research is performed inhouse to fill needed voids in available methods and to develop improved techniques and interfaces.

CFD is viewed as an integral part of the fully automated factory concept and is being integrated into the shared, common database that ties all design and manufacturing functions together. Its relationship to the advanced design process is illustrated schematically in Figure 3. When fully implemented on-line, analysis of aircraft and component designs can be made and fed directly into the design database.

In the larger scheme of things, CFD capability will interface through the shared database with the model building function to provide supportive evaluation of wind tunnel test configurations and, in turn, to access wind tunnel databases for calibration/validation of the codes as illustrated in Figure 4. In the future, this loop will include a structural design interface for support of detail design activities and manufacturing. Many aspects of the concept have been implemented at this time and segments of the system are in operation. It is the responsibility of the CFD Section to develop and to support the CFD codes that are used in the design and analysis process.

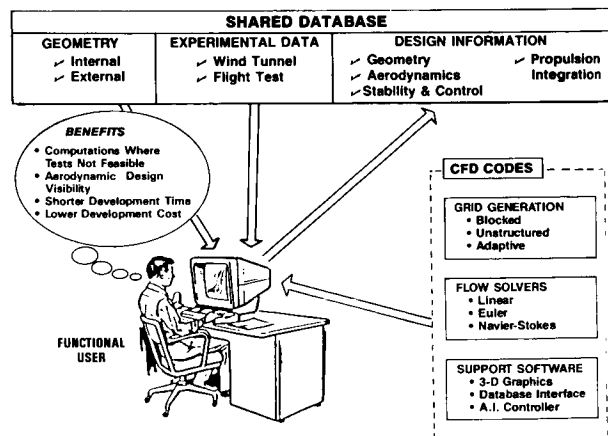
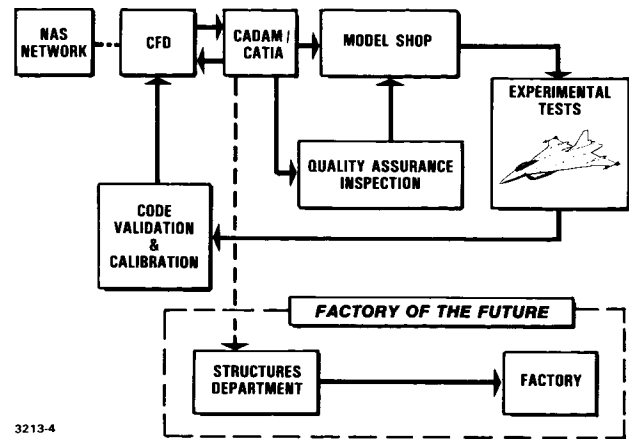

Figure 3. CFD as an Integral Part of the Design Process



3213-4

Figure 4. CFD as an Integral Part of the Factory of the Future

Organizational Structure

The organizational structure for developing a mature CFD capability and integrating the capability into the design process, at whatever level of maturity, is outlined in Figure 5. In the matrix concept employed at General Dynamics, the functional sections are responsible for supplying direct support to the various design programs. The CFD Section is a support function charged with providing the necessary codes and expertise for use by the functional discipline areas, much as a wind tunnel test section supplies test capability and expertise.

CFD expertise is concentrated in a single section that reports to the director, who has the responsibility for the functional sections. The CFD Section is divided into two groups: (1) a group responsible for code development, and (2) a group responsible for code applications. The general division of responsibilities is shown in Figure 5.

In the dynamic environment of CFD capability maturation, a maximum degree of flexibility must be maintained. Not only must a CFD Section provide usable and dependable applications-oriented codes, but the

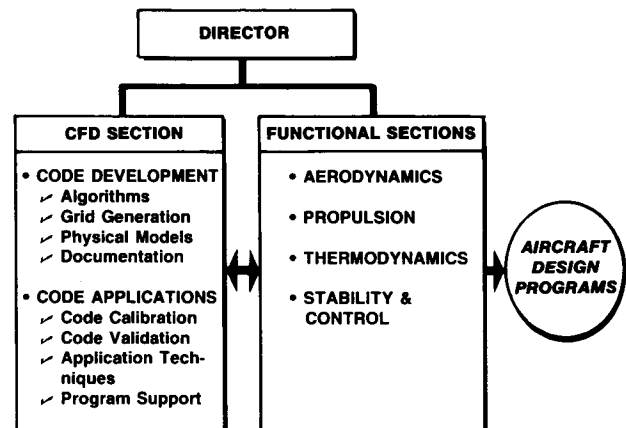

3213-5

Figure 5. Organizational Philosophy

intensive training of users skilled in making design applications must be accomplished. Organizational barriers can be detrimental to this latter function. Cross training is accomplished by a flexible loan-in procedure between the functional groups and the CFD applications group.

Under this arrangement, engineers from the various discipline groups within the functional sections are loaned into the CFD Applications Group to help in the important code calibration/validation activities, under the direction of the CFD specialists, thus receiving hands-on experience in the use of the codes. In turn, the CFD specialists are loaned into the functional groups to support specialized applications of CFD to design programs under the direction of the functional management, thus gaining appreciation for design applications requirements. This cross fertilization provides an essential element for building a strong, design-oriented CFD capability.

The CFD Section is charged with the responsibility of maintaining a documented file on all code applications that support the calibration and validation activities. This file contains the details of specific accuracy limitations of both the experimental data being used and the codes being calibrated. A documented reference source is thus available on application of all codes in order to build a base of experience for design confidence in CFD methods.

CFD APPLICATIONS

Applications of CFD to design are becoming a key element of the Fort Worth Divisions' activities. A few of the calibration activities underway in the applications areas of primary interest are discussed in the following paragraphs.

Grid generation is a complex issue that must be addressed with each configuration analysis, and often is as important as the algorithms that are used in the flowfield solution. This problem is particularly difficult when there is a high degree of integration of the aerodynamic and propulsive systems, or when there are other unique geometric features. The extreme difficulty of modeling complex regions with a single block of grid leads to the concept of multiple blocks, which is illustrated in Figure 6. With this approach, complex

problems can be subdivided into several smaller zones that can more accurately represent the geometry and the boundary conditions.

Another reason for using multiple blocks of grid is that the blocking can be controlled to divide the flowfield into zones wherein the sophistication of the analysis code can be matched to the complexity of the flowfield. Several zones of an aircraft flowfield and the types of analyses are illustrated in Figure 7. This approach also allows larger problems to be solved with a specified amount of computer core memory since only one block at a time must be in core memory, while the other blocks reside in other types of memory. The grid generation procedure is documented in References 2 and 3.

An Euler analysis of the F-16 is being accomplished as a benchmark calculation. Progress has been made and preliminary results were presented at an AGARD Symposium (Reference 4). Part of the grid system, which has over 500,000 grid points in 20 blocks, is shown in Figure 8. Detailed modeling of the inlet and nozzle with flow-through boundary conditions is essential for full aircraft simulation with power effects. Details of the inlet grid blocking are shown in Figure 9.

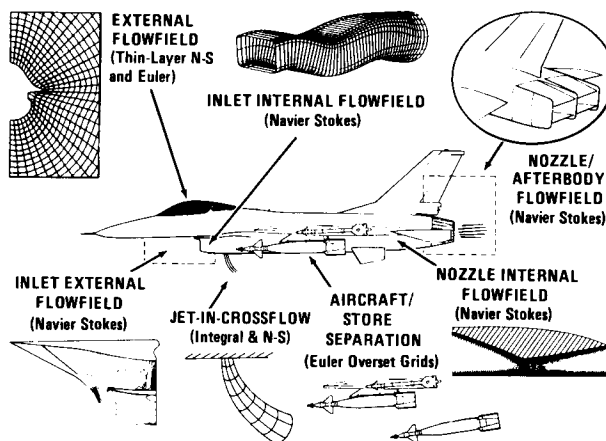

Figure 7. Zonal Approach to the Computation of Aircraft Flowfields

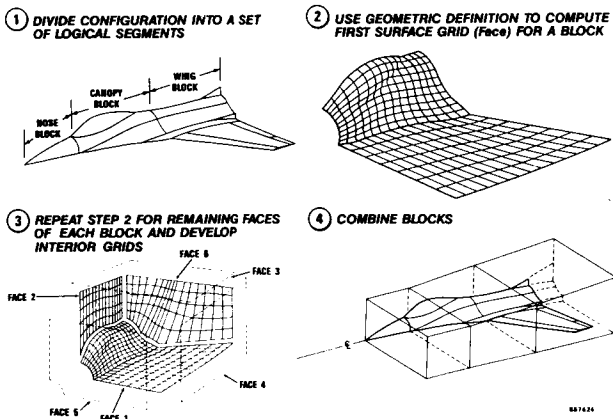

Figure 6. Concept of Multi-Block Grid Systems

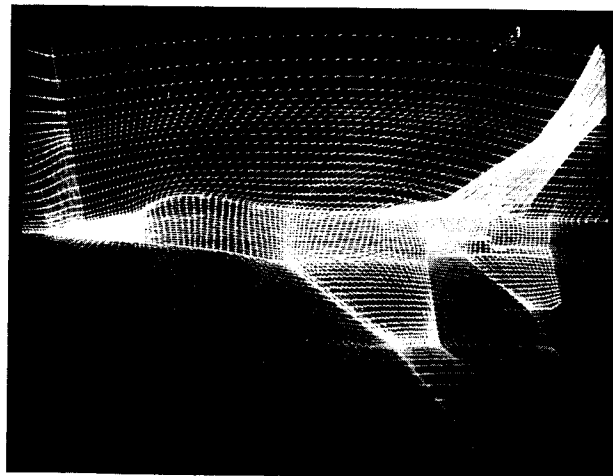

Figure 8. F-16 Grid System

ORIGINAL PAGE IS
OF POOR QUALITY

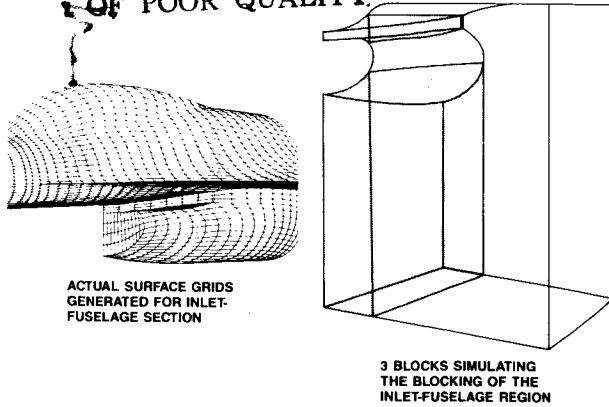

Figure 9. Blocking Scheme Applied to F-16 Inlet Region

Initial calculations, which were made on the Fort Worth Division CRAY XMP-24, utilized approximately 35 CPU hours. Computed velocity vectors on the surface of the forward fuselage are shown in Figure 10. The accuracy of the fuselage flowfield calculations was further verified by an excellent comparison between computational results and experimental pressure coefficients from Reference 5. Sample comparisons at two fuselage stations are shown in Figure 10.

Since this was the first time that an analysis of this magnitude had been attempted, it was no surprise that problems were encountered. The code simply did not develop shock waves at the downstream edge of the

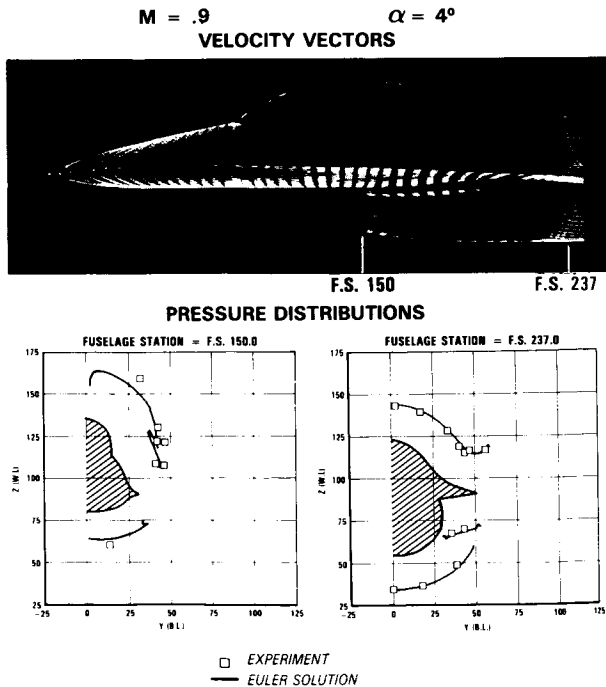

Figure 10. Euler Solution of F-16 Fuselage Flowfield

supersonic bubble on the wing upper surface; consequently, the pressures in this region were not good, as shown in Figure 11. The solution data indicate that the problem can be resolved by the use of (1) a denser grid on the wing upper surface, and (2) a revised solution algorithm that has a strong shock-capturing feature. Both the grid system and the code are being modified to incorporate these indicated improvements, and further computations are planned on the NASA/Ames Numerical Aerodynamics Simulator.

CFD can be used to solve flowfields for configurations in both pitch and yaw to determine lateral stability characteristics. This capability has not been widely explored, primarily because of the computational resources required for this type of analysis. An Euler analysis of a NASA wing/body/tail research model, illustrated in Figure 12, was performed. The analytical model contained 200,000 grid points, and about 25 CRAY CPU hours were used in obtaining the solution. As shown, the longitudinal characteristics and the lateral stability derivatives computed for a Mach number of 2.3 compared favorably with experimental force and moment data from Reference 6. The highly-swept delta wing of this configuration offered a challenge in capturing the wing leading-edge vortex that is known to dominate this type of flowfield. The force and moment data simply indicate that the vortical flow over the wing was properly simulated. The Mach contours, shown in Figure 13, offer positive evidence that the strong wing vortex was present in the solution.

Other challenging applications for CFD are in the areas of inlets and nozzles. An example of a Navier-Stokes analysis of an axisymmetric inlet at angle of attack is illustrated in Figure 14. The results of this study were presented at an AIAA Conference (Reference 7). Computed pressures on the spike and cowl compared favorably with experimental data. A sample comparison along the upper spike centerline is shown in Figure 14 for

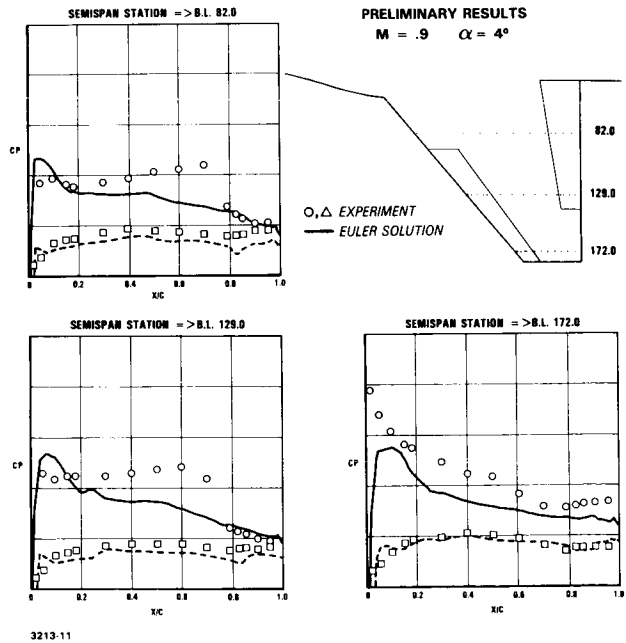
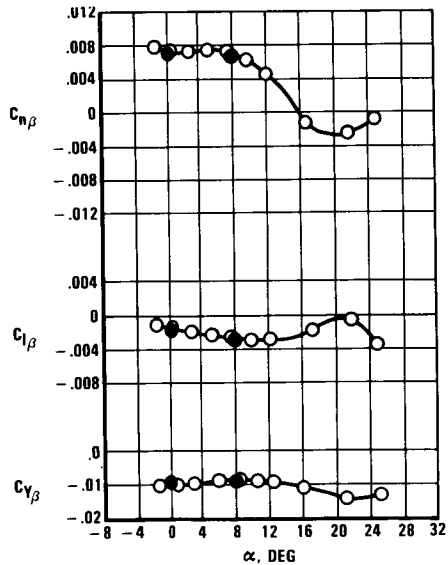
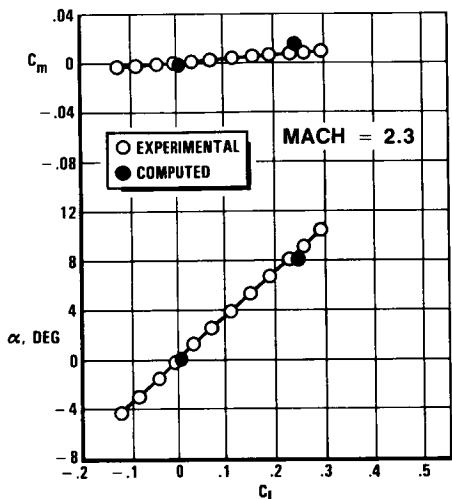
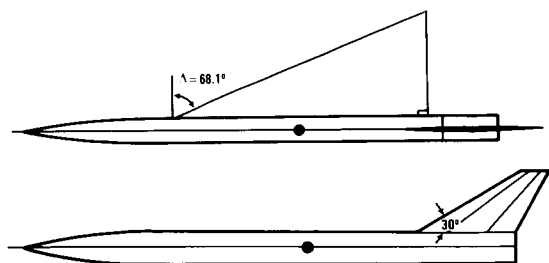

Figure 11. Euler Solution of F-16 Wing Flowfield

ORIGINAL PAGE IS
OF POOR QUALITY



3213-12

Figure 12. Euler Solution for Stability Derivatives



Figure 13. Wing Vortex Defined by Mach Contours

an angle of attack of 8 degrees. Computed Mach number contours in the flowfield of this inlet, Figure 15, show the non-symmetric location of the shock and the expansion waves.

CFD also offers the potential to solve some of the special problems that are associated with high-performance military aircraft. One such problem that has defied a good experimental solution is that of an unsteady flowfield of a weapons bay. Unsteady aerodynamic flow, or weapons bay buffet as it is commonly called, has been known to damage both the weapons bay doors and the weapons inside. Although a generalized solution to this problem has not been developed, a two-dimensional, time-dependent Navier-Stokes solution was obtained for supersonic flow over a cavity in order to establish the viability of CFD as a tool to handle this problem.

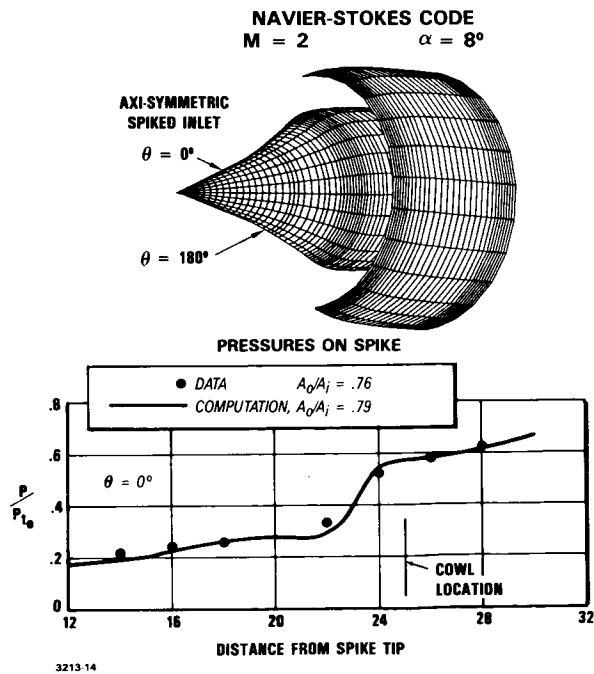

3213-14

Figure 14. Navier-Stokes Solution of a Spiked Inlet Flowfield

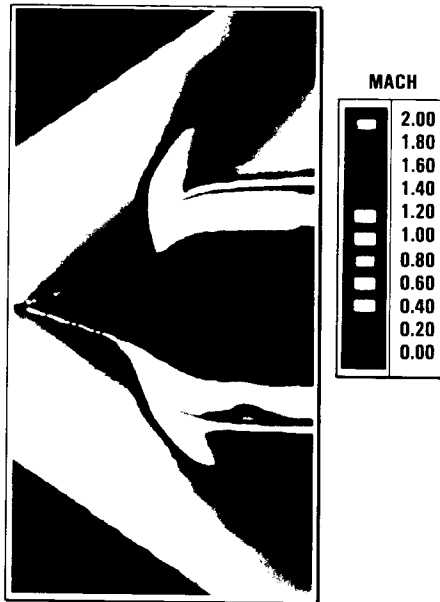

Figure 15. Mach Number Contours in the Flowfield of a Spiked Inlet

The two-dimensional solution of unsteady flow in a cavity was obtained with a Navier-Stokes solver. The model was comprised of approximately 26,000 grid points and was given an initial starting solution of 1.5 Mach number in the freestream and zero velocity in the cavity. The code was run for 70,000 iterations, which represented about 17 milliseconds of real time. Although this seems like a short duration, it was enough to allow cyclic fluctuations to become apparent in the solution. Some of the pressure contours in the flowfield are shown in Figure 16 at several different times during the solution to give a cursory depiction of the results. A video movie was also made that presents the data in an informative manner showing pressure waves as they move about within the cavity.

CONCLUDING REMARKS

CFD capability is maturing rapidly and is now being applied to the design process to help deal with aerodynamic phenomena encountered in the complex flowfields associated with high performance aircraft. This expanding capability is presenting new technical and managerial challenges throughout engineering. To the aircraft designer, it is the challenge to learn a new and different tool. He must responsibly question CFD and confirm that it can provide the needed capability, turnaround time, skill level, availability, cost effectiveness, and confidence level to justify its use. To the manager, it is the challenge to integrate a new capability into an existing organization. Responsibilities for CFD may sometimes overlap between functional groups and the projects on which the codes are applied. Managers must also provide safeguards to assure that only verified or calibrated codes are used in the design process. An approach to the solution of these issues has been presented.

Some sample calculations have been shown to illustrate potential design applications. While these examples, in some cases, represent early attempts at complex flow solution, it is anticipated that continued improvements in hardware and solution algorithms will make such applications routine in the future. The resurgence of interest in hypersonic technology is pressing the need for rapid advancement of CFD capability.

On this occasion of the formal opening of NASA's Numerical Aerodynamic Simulator Facility, NASA is to be congratulated for its pioneering efforts in developing both the hardware and software for this important CFD capability. The dedicated efforts of NASA's management and skilled researchers have laid the foundation for a national capability that is clearly a world leader.

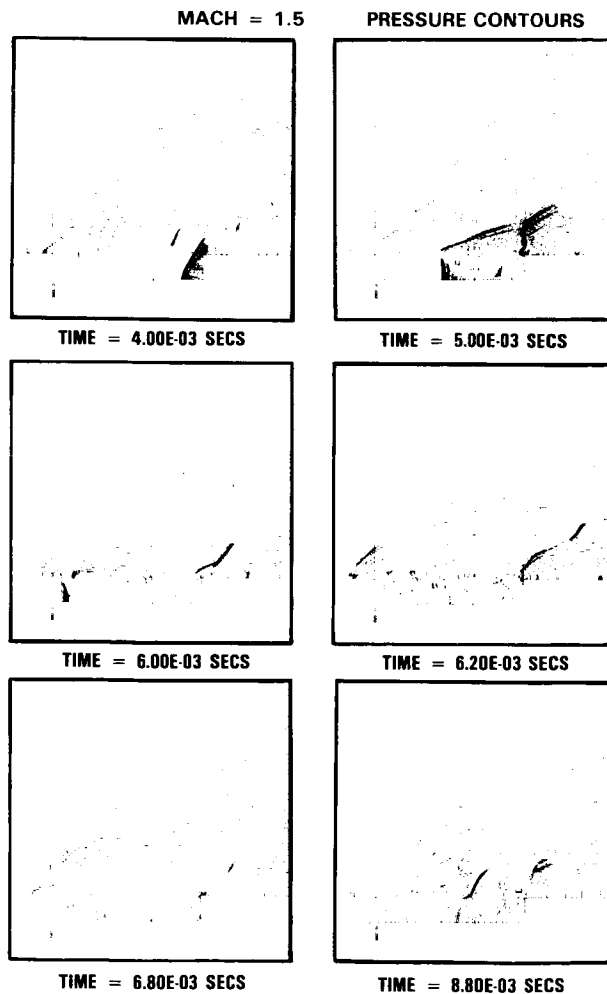

Figure 16 Time-Dependent Navier-Stokes Solution of a Cavity Flowfield

ORIGINAL PAGE IS
OF POOR QUALITY

REFERENCES

1. Current Capabilities and Future Directions in Computational Fluid Dynamics. National Research Council, National Academy Press, Washington, D.C. 1986.
2. Steinbrenner, John P.: GRIDGEN2D, Interactive Elliptic Surface Grid Generation. General Dynamics Report No. CFD 063-4-8601, June 13, 1986.
3. Reed, Christopher L.; and Karman, Steve L., Jr.: Multiple-Block Grid Method Applied to Complex 3-D Geometries. Presented at 1986 National Meeting of the Society for Industrial and Applied Mathematics, Boston, Mass., July 1986.
4. Karman, Steve L., Jr.; Steinbrenner, John P.; and Kisielewski, Keith M.: Analysis of the F-16 Flow Field by a Block Grid Euler Approach. AGARD Paper No. 18, 58th Meeting of the Fluid Dynamics Panel Symposium, Aix En-Provence, France, April 1986.
5. Reue, G. H.; Doberenz, M. E.; and Wilkins, D. D.: Component Aerodynamic Loads From 1/9-Scale F-16A Loads Model. General Dynamics Report No. 16PR316, May 1976.
6. Jernell, Lloyd S.: Stability Characteristics at Mach Numbers from 1.60 to 4.63 of Several Wing-Body-Tail Models Having Wings with Arrow, Delta, and Diamond Planforms. NASA TM X-1485, December 1967.
7. Howlett, D. G.; and Hunter, L. G.: A Study of a Supersonic Axisymmetric Spiked Inlet at Angle of Attack Using the 3-D Navier-Stokes Equations. AIAA Paper No. 86-0308, 24th Aerospace Sciences Meeting, Reno, Nevada, January 1986.