

NASA Contractor Report 179649

# Composition Optimization of Chromium Carbide Based Solid Lubricant Coatings for Foil Gas Bearings at Temperatures to 650 °C

(NASA-CR-179649) COMPOSITION OPTIMIZATION OF CHROMIUM CARBIDE BASED SOLID LUBRICANT COATINGS FOR FOIL GAS BEARINGS AT TEMPERATURES TO 650 C Final Contractor Report (Case Western Reserve Univ.) 20 p G3/27 0087902 N87-26233 Unclas

Christopher DellaCorte  
*Case Western Reserve University*  
*Cleveland, Ohio*

July 1987

Prepared for  
Lewis Research Center  
Under Grant NCC 3-30

**NASA**

National Aeronautics and  
Space Administration

COMPOSITION OPTIMIZATION OF CHROMIUM CARBIDE BASED SOLID LUBRICANT COATINGS  
FOR FOIL GAS BEARINGS AT TEMPERATURES TO 650 °C

Christopher DellaCorte\*  
Case Western Reserve University  
Department of Mechanical and Aerospace Engineering  
Cleveland, Ohio 44106

SUMMARY

This paper describes a test program to determine the optimum composition of chromium carbide based solid lubricant coatings for compliant gas bearings. The coatings contain a wear resistant chromium carbide "base stock" with the lubricant additives silver and barium fluoride/calcium fluoride eutectic. The friction and wear properties of the coatings are evaluated using a foil gas bearing test apparatus.

The optimum amounts of each constituent were determined in a previous study using a pin-on-disk test apparatus. The coating composition optimization is repeated in this study for air lubricated foil gas bearings from 25 to 650 °C. The various coating compositions were prepared by powder blending, then plasma sprayed onto Inconel 718 test journals and diamond ground to the desired coating thickness and surface finish. The journals were operated against preoxidized nickel-chromium alloy foils. The test bearings were subjected to repeated start/stop cycles under a 14 kPa (2 psi) bearing unit load. Sliding contact between the coated journal and smooth foil occurs during bearing start-up before lift-off or hydrodynamic lubrication by the air film is achieved and during bearing coastdown. The bearings were tested for 9000 start/stop cycles or until specimen wear reached a predetermined failure level.

In general, the addition of silver and eutectic to the chromium carbide "base stock" significantly reduced foil wear and increased journal coating wear. The optimum coating composition, PS212 (70 wt % metal bonded Cr<sub>3</sub>C<sub>2</sub>, 15 wt % Ag, 15 wt % BaF<sub>2</sub>/CaF<sub>2</sub> eutectic), reduced foil wear by a factor of two and displayed coating wear well within acceptable limits.

The load capacity of the bearing using the plasma-sprayed coating prior to and after a run-in period is ascertained and compared to polished Inconel 718 specimens.

INTRODUCTION

The foil gas bearing is a hydrodynamic bearing that uses ambient air as its working fluid. Foil bearings can, therefore, operate in environments where high temperatures preclude the use of lubricating oils and greases. Potential applications include the shaft bearings on small high temperature turbines. Because of the low viscosity of the lubricating gas film, foil bearings also exhibit very low frictional drag compared to liquid lubricated or rolling element bearings. Foil bearings do, however, experience sliding contact between

---

\*NASA Resident Research Associate.

the thin (typically 0.100 mm) foil and the journal during bearing start-up prior to achieving hydrodynamic lubrication or lift-off and during bearing coastdown prior to stopping. Backup lubrication must be provided to prevent foil wear and reduce starting torque of the bearing over a wide temperature range from room temperature to 650 °C. Plasma-sprayed chromium carbide based coatings with solid lubricant additives silver and barium fluoride/calcium fluoride eutectic have been investigated at NASA Lewis Research Center, to provide back-up lubrication for foil bearings (ref. 1).

Chromium carbide has excellent wear resistance and thermal stability but exhibits high friction and has the tendency to wear counterface materials when used in sliding contacts. By adding the solid lubricants silver and barium fluoride/calcium fluoride eutectic to the chromium carbide its tribological properties can be greatly improved (refs. 1 and 2). Silver, because of its low shear strength provides lubrication at low temperatures and the eutectic has been shown to effectively lubricate at high temperatures (ref. 3). Therefore, coatings containing both silver and the eutectic should exhibit stable friction coefficients over a wide temperature range. Like chromium carbide, silver and the eutectic are thermally and chemically stable to at least 900 °C in air, helium, or hydrogen.

The tribologically optimum coating composition was determined in a previous study using a pin-on-disk tribometer (ref. 2). This paper repeats the composition optimization for foil gas bearings using a gas bearing test rig. This work expands the database for high temperature lubrication of foil bearings and provides a means to check the correlation of pin-on-disk tests and actual bearings. The test environment is ambient air at temperatures from 25 to 650 °C. Coating performance is judged by tribological characteristics, especially foil or counterface material wear since foil wear is typically the factor that limits overall bearing life.

The coating composition domain is limited to compositions that contain at least 60 wt % metal-bonded chromium carbide and 1:1 ratio amounts of additives because previous work with this coating system indicates that these are potentially good friction and wear coatings (ref. 1).

## EXPERIMENTAL MATERIALS

### Foil Bearing

The foil bearing is made of a nickel-chromium alloy, Inconel X-750. It exhibits excellent high temperature physical properties, including high elastic deformability, which is crucial to the successful operation of a compliant foil bearing. The bearing consists of a corrugated bump foil and a smooth top foil. The bump foil provides increased compliance and damping to the bearing unit and the smooth top foil transmits the gas film pressure into bearing load support. The bearing dimensions are given in figure 1.

### Foil Oxidation Pretreatment

The foils are preoxidized in air at 704 °C to produce a thin film of chromium oxide,  $\text{Cr}_2\text{O}_3$ , on the bearing surface that helps lubricate the bearing during sliding contact. When present in a highly loaded, nonconforming

contact such as a pin on a disk, chromium oxide apparently acts as an abrasive not as a lubricant (ref. 5). But in a lightly loaded, conforming contact like the foil bearing, the chromium oxide forms as a thin coherent film and has been shown to be a good lubricant (ref. 6). During sliding at elevated temperatures, the oxide layer on the foil is replenished as quickly as it is worn away. However, at lower temperatures, the oxide layer is not replenished, thus the lubrication must come from lubricants in the journal coating.

### Test Journal

The test journals are made of Inconel 718. Figure 2 shows the dimensions of the test journal. The journal's outside diameter is undercut by 0.500 mm to accommodate the 0.250 mm thick coating that will be applied.

### Test Coatings

Four lubricant coating compositions are tested in this program. One coating, PS218, contains only the metal-bonded chromium carbide with no added lubricants. It functions as the control or baseline coating composition to which the modified coatings are compared. The three other compositions tested have varied amounts of a 1:1 by weight mixture of silver and BaF<sub>2</sub>/CaF<sub>2</sub> eutectic additives. They are: PS200 which contains 80 wt % metal-bonded Cr<sub>3</sub>C<sub>2</sub> and 10 wt % each of Ag and the eutectic, PS212 which contains 70 wt % metal-bonded Cr<sub>3</sub>C<sub>2</sub> and 15 wt % each of Ag and the eutectic, and PS213 which contains 60 wt % metal-bonded Cr<sub>3</sub>C<sub>2</sub> and 20 wt % each of Ag and the eutectic. The compositions and mesh sizes of the component plasma-spray powders are given in table I.

### Powder Preparation

The compositions are prepared by physically blending appropriate amounts of each component in powder form and then applying the mixture to the test journals by plasma-spraying. The metal-bonded chromium carbide powder and the silver powder are available as commercial plasma-spray powders. The barium fluoride/calcium fluoride eutectic is prepared by mixing BaF<sub>2</sub> and CaF<sub>2</sub> reagent grade powders in eutectic proportions then melting them in a clean nickel crucible in a tube furnace at 1100 °C in a nitrogen atmosphere. The resulting fused block is then crushed in a mechanical plate crusher into particles approximately 1 to 2 mm in diameter. These particles are further ground in a ball mill using aluminum oxide crushing stones until the eutectic is a fine powder. The powder is then sieved to obtain eutectic particles which are between 44 and 70 μm in diameter. X-ray diffraction of the eutectic powder indicates that calcium fluoride and barium fluoride are present with no other phases detected.

### Plasma Spraying

The journal surface to be coated is first sandblasted then plasma-sprayed with a thin, 0.075 mm NiCr (80 wt % Ni, 20 wt % Cr) bond coat. The test coating is then plasma-sprayed over the bond coat to a total coating thickness (bond coat and lubricant coat) of 0.375 mm. The plasma-spray parameters are given in table II.

## Diamond Grinding

The plasma-sprayed coating is diamond ground back to a total coating thickness of 0.250 mm. Appendix A outlines the recommended grinding procedure used in this program. Generally, if the grinding depth per pass is more than 0.0250 mm, the grinding wheel has the tendency to pluck the soft phase lubricant additives from the coating surface leaving behind raised carbide rich areas which abrade counterface materials. If the grinding depths per pass are too shallow (less than 0.00250 mm), the grinding wheel has the tendency to smear the nickel/cobalt bond material over the coating surface, covering the lubricants. Figure 3 is a conceptual illustration of these ground surfaces.

## Test Apparatus

Figure 4 is an illustration of the test rig used in this study. A complete description of the apparatus is given in reference 4. The features important to this study are outlined below.

The test apparatus is designed to run unattended. The motor is controlled by timer switches which start and stop the motor over a 20 sec test cycle. The test specimens are heated by a quartz radiant type heater. The heater box splits in half to facilitate specimen inspection and removal. The heater is controlled by a solid state PID controller which measures bearing temperature with a thermocouple located on the foil bearing housing in the immediate vicinity of the test bearing. The overall duration of a set of test cycles is controlled by on/off type programmable timer switches that override the cycle timer switches and the PID heater controller. These programmable timer switches make it possible to control the overall duration of a test as well as when the heaters are operating.

The test spindle is driven by a 1 hp electric motor and rotates at 13 800 rpm. The spindle is turned on for 13 sec and off for 7 sec giving a total cycle time of 20 sec. This allows the test bearing to fully lift off after startup and come to a complete stop after motor shut down. A fiber optics probe is used to measure the spindle speed and count each cycle. Safety features for the test rig include oil and bearing over temperature alarms, torque overload alarm, and spindle bearing oil supply and oil return flow alarms. The test rig is shut off automatically if an alarm is tripped.

The foil bearing is mounted in a housing which, after lift off, floats over the rotating test journal on a hydrodynamic film of air. The bearing housing is loaded with deadweights to provide a 14 KPa (2 psi) static load on the bearing.

Bearing housing rotation is prevented by a torque arm that bears against a stationary cantilevered flexure plate located above the test bearing. The amount of deflection of the plate is a function of the applied torque and is measured using a capacitance probe which is calibrated at room and elevated temperatures.

The journal velocity and bearing torque are continuously recorded by a strip chart recorder. An oscillograph recorder is used to study experimental transients.

## Test Procedure

The coated test journals were vacuum baked at 150 °C for 3 hr to remove any volatile residue remaining from the grinding operation and subsequent handling. The journals were then cleaned with pure ethyl alcohol, lightly scrubbed with levigated alumina, rinsed with deionized water, and dried. The cleaned journal is mounted onto the test spindle and the runout is reduced to less than 0.00750 mm by indexing the journal with respect to the spindle or using appropriate shims.

The foils are placed in the bearing housing and held in place by tapered pins driven through the foil keys. The bearing housing assembly is then mounted on the test journal, the motor started and bearing lift off is verified. Figure 5 is a drawing of the assembled bearing and journal.

The tests are run in a series of six sets of 1500 start/stop cycles or a total of 9000 start/stop cycles for each test journal and foil. The tests may be terminated earlier if the torque or specimen wear become unacceptably high. Each set of 1500 cycles is run over the entire temperature range of room temperature to 650 °C in the following order:

For the first 1500 cycle set the bearing is run:

- 500 start/stops at 650 °C
- 500 start/stops at 25 °C
- 500 start/stops during heating from 25 to 650 °C

For the following sets the bearing is run:

- 500 start/stops at 25 °C
- 500 start/stops during heating from 25 to 650 °C
- 500 start/stops at 650 °C

The initial set is run first at 650 °C and then at room temperature to allow the coating to run-in at the highest temperature because it may be less abrasive to the thin foil. Test sets 2 through 6 are run as outlined above to simulate the gradual heating of a bearing and to facilitate test temperature programming. The bearing temperature for the 500 start/stop cycles during the heating mode is monitored and plotted in figure 6. Foil wear and journal wear are measured at the end of each set using micrometers. A surface profile of the journal is made after testing is completed to more accurately determine coating wear.

## RESULTS AND DISCUSSION

### Torque

The torque data collected for the tests is summarized in table III. The uncertainties reported represent the standard deviations of the test data from repeated experiments. The significant amount of data overlap indicate that, under these conditions, the coating composition does not have a large effect on the starting or stopping torque of the test bearing.

The starting torque over the entire temperature range is lower than the stopping torque. This can be attributed, in part, to the rotational inertia of the bearing assembly which reduces the measured starting torque during bearing start-up. Both the starting and stopping torque at room temperature is higher than at 650 °C. This is probably due to the increased lubrication effect of the eutectic and chromium oxide present at the sliding interface during elevated temperature tests.

#### Foil Wear

The foil wear data is given in table IV. Foils that were run against the unmodified coating, PS218, showed severe wear. In fact, these tests had to be prematurely ended after 3000 start/stop cycles because foil wear had exceeded 33 percent of the original foil thickness, the predetermined failure point. One test with the PS218 coating was continued to confirm that the high wear rate was a steady-state condition and not the result of run-in type wear. The foil bearing specimen from this test was severely worn; exhibiting a 55 percent reduction in the original foil thickness after 9000 start/stop cycles.

Markedly lower wear occurred for foils sliding against the modified coatings PS200, PS212, and PS213 than for foils sliding against the unmodified coating, PS218. The use of PS212 (70 wt % metal bonded  $\text{Cr}_3\text{C}_2$ , 30 wt % silver and eutectic) resulted in the lowest foil wear; with a loss of only 17.5 percent in foil thickness after the 9000 start/stops. The use of PS200 and PS213 resulted in slightly higher foil wear which was 25 and 22.5 percent of the foil thickness respectively. Therefore, the PS212 coating is optimum for this coating system, in terms of minimum foil wear.

#### Coating Wear

Table V summarizes the journal coating wear. The coating wear for the modified coatings follows the same trend as the foil wear. PS212 had the lowest wear factor,  $6.5 \times 10^{-6} \text{ mm}^3/\text{N-m}$ , followed by PS200 and PS213 which had wear factors of  $8.8 \times 10^{-6}$  and  $10.7 \times 10^{-6} \text{ mm}^3/\text{N-m}$  respectively. The unmodified coating, PS218, exhibited, by far the lowest coating wear factor,  $1.7 \times 10^{-6} \text{ mm}^3/\text{N-m}$ . This result, however, is inconsequential when the unacceptable foil wear is taken into account. Appendix B explains the wear factor and how it relates to these tests.

#### Discussion of Test Results

All three of the modified coatings, PS212, PS200, and PS213, successfully completed the 9000 start/stop test sequence. The unmodified coating showed the lowest coating wear but displayed unacceptably high foil wear which caused test termination at only 3000 start/stop cycles.

Among the three modified coatings, PS212 displayed the lowest coating wear and the lowest foil wear (figs. 7 and 8). One plausible reason for this behavior can be seen by comparing the transfer films from the coating which accumulate on the foil surface during testing. Figure 9 shows the EDS x-ray (Energy Dispersive x-ray Spectroscopy) level spectra of the foil surfaces after sliding against the modified coatings. The foil slid against PS212 has the highest

levels of silver and eutectic (indicated by Ca and Ba peaks) at the sliding surface.

Since lubricant transfer has been determined in a previous study (ref. 1) as beneficial to low friction and wear with this coating system, this may be a reason why PS212 performs better than the other modified coatings. The transfer materials act as a low shear strength film at the sliding interface, reducing the wear of the coating and counterface foil material.

Figure 10 is the EDS x-ray spectrum of a foil surface after sliding against the unmodified coating, PS218. No elements are detected except those present in the foil material, Inconel X-750. Thus, there is no transfer of material from the coating to the foil surface. This effect is probably due to the rapid wear rate of the foil; any material transfer to the foil from the coating is quickly worn away by the journal. When sliding against Inconel X-750 foils, the unmodified coating acts as an abrasive counterface material unlike the modified coatings which seem to act as reservoirs of the foil bearing lubricants.

### Bearing Load Capacity

The load capacity of foil bearings is an important bearing parameter which is dependent, in part, upon the geometry of the bearing and upon the gas lubricating film that develops between the rotating shaft and the foil. Since the gas lubricating film is thin, typically less than  $2.5 \mu\text{m}$ , the surface topography of the journal, particularly surface roughness, can have a significant effect on the fluid flow in the gas film and hence, on the load capacity as well.

Therefore, the load capacity of the bearing was ascertained for the following three journal surfaces: a fully dense, polished Inconel 718 journal, an "as ground" plasma-sprayed PS200 coating, and a plasma-sprayed PS200 coating that had been run-in over 1000 start/stop cycles. The surface finishes of the test specimens were  $0.101 \pm 0.005 \mu\text{m}$  for the stainless steel journal,  $0.81 \pm 0.05 \mu\text{m}$  for the "as ground" PS200 journal, and  $0.152 \pm 0.010 \mu\text{m}$  for the run-in PS200 journal.

The procedure for determining the load capacity is as follows: The journal is started and the bearing is allowed to completely lift off at the customary 14 kPa (2 psi) load and a shaft surface velocity of 26.7 m/s after lift-off. Deadweights are added to the bearing housing at 100 g (1.4 kPa) increments and the bearing is allowed to stabilize at the new load. A torque reading is recorded. The load is increased until the torque rises sharply and the bearing temperature increases indicating sliding contact. This procedure is repeated two more times to achieve confidence in the load capacity measurement.

The results of the load capacity tests are given in table VI and plotted in figure 11. The Inconel 718 journal had the highest load capacity, 51 kPa (7.3 psi) followed by the run-in plasma-sprayed coating, 41 kPa (5.9 psi). As expected, the rough as ground plasma-sprayed surface had the lowest load capacity, 28 kPa (4 psi). It should be understood that these are the load capacities at 26.7 m/s. Surface velocities are much higher for foil bearings in turbomachinery, and the load capacity would be correspondingly much higher.



However the relative ranking of the three types of journal surfaces are expected to be the same at these higher velocities.

This trend of load capacity versus surface finish indicates that the plasma-sprayed coatings cannot support maximum loads during initial operation but can support much higher loads after a brief run-in period that smooths out the coating surface.

### CONCLUSIONS

From the results of these tests, the following general conclusions can be made.

1. The optimum coating composition for this application is PS212 (70 wt % metal-bonded chromium carbide, 15 wt % Ag, 15 wt % BaF<sub>2</sub>/CaF<sub>2</sub> eutectic). It survived 9000 start/stop cycles and displayed the lowest foil and coating wear of the modified coatings.

2. The friction of the coating for this lightly loaded conforming geometry bearing is not significantly affected by coating composition.

3. The unmodified coating, PS218 with no silver or fluoride eutectic in its composition, displayed low journal coating wear but severe foil wear caused test termination after only 3000 start/stop cycles.

4. The foils slid against the optimum coating, PS212, had the highest transfer film of lubricants to the foil surface which may be beneficial to reducing wear.

5. The plasma-sprayed coating can support only light loads during initial operation but can support much higher loads after a brief run-in period that smooths the coating surface.

6. The addition of silver and barium fluoride/calcium fluoride eutectic to the metal-bonded chromium carbide coating significantly reduces the counter-face material wear while increasing the journal coating wear within acceptable limits. By adding the lubricants to the system the foils were able to endure the full 9000 start/stop test sequence.

## APPENDIX A. - RECOMMENDED GRINDING PROCEDURE

1. Use diamond grinding only.
2. Use water as lubricant-use no oil.
3. Initial grinding depth should be 0.0250 mm.
4. Final cuts should be 0.001 to 0.0150 mm.
  - Taking too deep a cut, i.e., 0.10 mm, will pluck softer phases (Ag and  $\text{BaF}_2/\text{CaF}_2$ ) from surface.
  - Taking too light a cut, i.e., less than 0.010 mm, will smear the metal-bonded chromium carbide. This will result in an "orange peel" type finish.
5. Ground surface should be matte not glossy and have a speckled appearance representing the three separate phases.

## APPENDIX B. - EXPLANATION OF WEAR FACTORS

The wear factor (K) used in this paper is a coefficient which relates the volume of material worn from a surface to the distance slid and the normal load at the contact. Mathematically, K is defined as:

$$K = V/(SxW)$$

where

W the normal load at the sliding contact in kg  
S the total distance slid in mm  
V the volume of material worn away in mm<sup>3</sup>

The physical interpretation of the numeric value of the K factor is as follows:

$K = 10^{-4}$  mm<sup>3</sup>/N-m high wear

$K = 10^{-5}$  to  $10^{-6}$  mm<sup>3</sup>/N-m moderate to low wear

$K = 10^{-7}$  mm<sup>3</sup>/N-m very low wear

## REFERENCES

1. Wagner, R.C.; and Sliney, H.E.: Effects of Silver and Group II Fluoride Solid Lubricant Additions to Plasma-Sprayed Chromium Carbide Coatings for Foil Gas Bearings to 650 °C. *Lubr. Eng.*, vol. 42, no. 10, Oct. 1986, pp. 594-600.
2. DellaCorte, C.; and Sliney, H. E.: Composition Optimization of Self-Lubricating Chromium-Carbide-Based Composite Coatings for Use to 760 °C. *ASLE Trans.*, vol. 30, no. 1, Jan. 1987, pp. 77-83.
3. Sliney, H.E.; and Graham, J.W.: Tribological Properties of Self-Lubricating Fluoride-Metal Composites to 900 °C (1650 °F) - A Review and Some New Developments. *J. Lubr. Technol.*, vol. 97, no. 3, July 1975, pp. 506-511.
4. Bhushan, B.: Development of R.F. Sputtered Chromium Oxide Coating for Wear Application. *Thin Solid Films*, vol. 64, 1979, pp. 231-241.
5. DellaCorte, C.; and Sliney, H.E.: Effects of Atmosphere on the Tribological Properties of a Chromium Carbide Based Coating for Use to 760 °C. *ASLE Preprint 87-AM-8A-1*, 1987. (NASA TM-88894).
6. Bhushan, B.: Friction and Wear Results from Sputter-Deposited Chrome Oxide With and Without Nichrome Metallic Binders and Interlayers. *J. Lubr. Technol.*, vol. 103, no. 2, Apr. 1981, pp. 218-227.

TABLE I. - COMPOSITION OF THE THREE  
MAJOR COATING COMPONENTS

Component	Composition, wt %	Particle size
Bonded chromium carbide		
Ni	28	-200 + 400 Mesh
Al	2	
Cr <sub>3</sub> C <sub>2</sub>	58	
Co	12	
Silver metal		
Ag	100	-100 + 325
Prefused eutectic		
BaF <sub>2</sub>	62	-200 + 325
CaF <sub>2</sub>	38	

TABLE II. - TYPICAL PLASMA SPRAY PARAMETERS

Parameter	Material, value
Arc gas, 1.4 m <sup>3</sup> /hr	Argon
Powder carrier gas, 0.4 m <sup>3</sup> /hr	Argon
Coating powder flow rate, kg/hr	1
Amperage, A	450 to 475
Voltage, V	32
Gun to specimen distance, mm	~150

TABLE III. - SUMMARY OF BEARING STARTING AND STOPPING TORQUE FOR VARIOUS  
COATING COMPOSITIONS

Coating I.D. number	Total wt % lubricant additives	T startup, N-mm	T stopping, N-mm	T startup, N-mm	T stopping, N-mm
		Room temperature		650 °C	
PS218	0	106.7±10.6	129.4±7.0	82.7±1.4	95.4±4.2
PS200	20	109.6±6.4	118.1±4.2	89.8±9.9	96.8±9.9
PS212	30	99.0±13.4	114.5±12.0	69.3±8.5	96.1±13.4
PS213	40	111.0±12.0	120.9±7.8	101.1±13.4	108.2±13.4

TABLE IV. - SUMMARY OF FOIL WEAR FOR FOILS SLID AGAINST  
VARIOUS JOURNAL COATINGS AFTER 9000 START/STOP CYCLES

Coating I.D. number	Percent reduction in foil thickness	Foil thickness wear, mm
PS218	55	0.056
PS200	25	.025
PS212	17.5	.018
PS213	22.5	.023

TABLE V. - SUMMARY OF COATING WEAR FACTOR, K, FOR VARIOUS  
JOURNAL COATINGS

Coating I.D. number	Total wt % added lubricants	K factor, in cc/cm-kg	K factor, in mm <sup>3</sup> /N-m
PS218	0	$1.7 \times 10^{-10}$	$1.7 \times 10^{-6}$
PS200	20	$8.6 \times 10^{-10}$	$8.8 \times 10^{-6}$
PS212	30	$6.4 \times 10^{-10}$	$6.5 \times 10^{-6}$
PS213	40	$10.5 \times 10^{-10}$	$10.7 \times 10^{-6}$

TABLE VI. - BEARING LOAD CAPACITY FOR VARIOUS JOURNAL  
MATERIALS AND SURFACE FINISHES AT ROOM TEMPERATURE

Journal material	Surface finish, $\mu\text{m rms}$	Load capacity, kPa
Inconel 718	$0.101 \pm 0.005$	51
PS200 As ground	$0.81 \pm 0.05$	28
PS200 After run-in of 1000 start/stop cycles	$0.152 \pm 0.010$	41

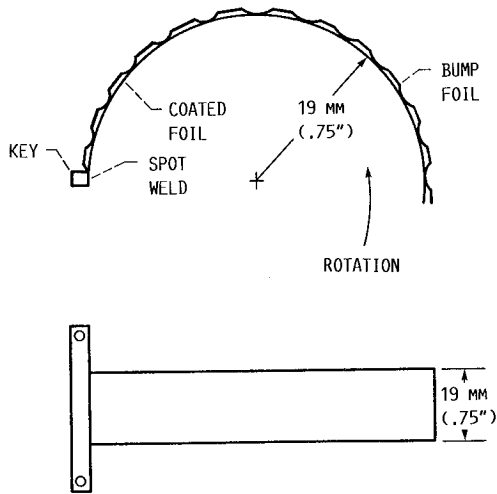

FIGURE 1. - COMPLIANT FOIL GAS BEARING ASSEMBLY.

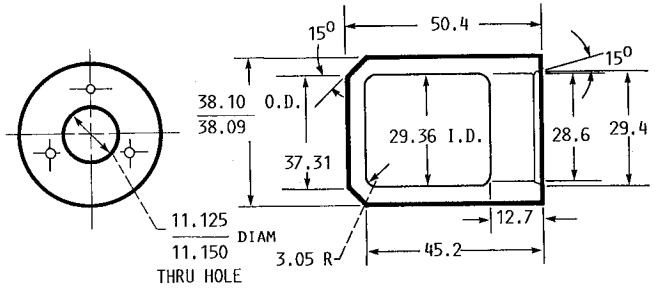

FIGURE 2. - JOURNAL FOR COMPLIANT FOIL GAS BEARING. MATERIAL, INCONEL 718. DIMENSIONS ARE IN MILLIMETERS.

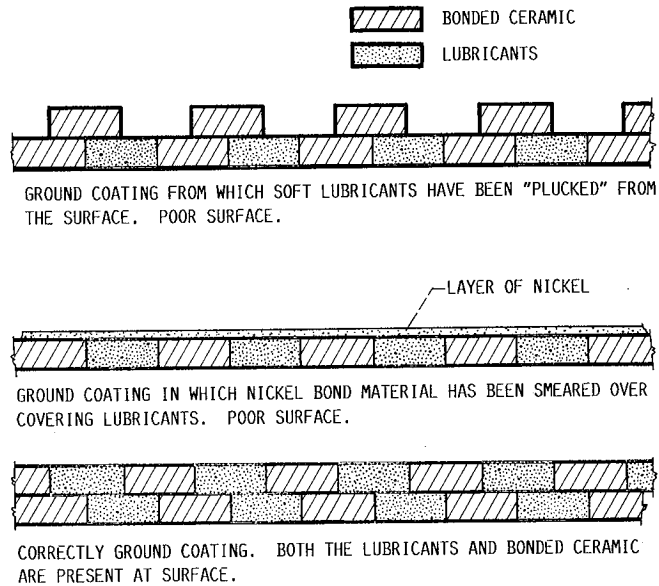

FIGURE 3. - CROSS-SECTION OF DIAMOND GROUND SURFACES.

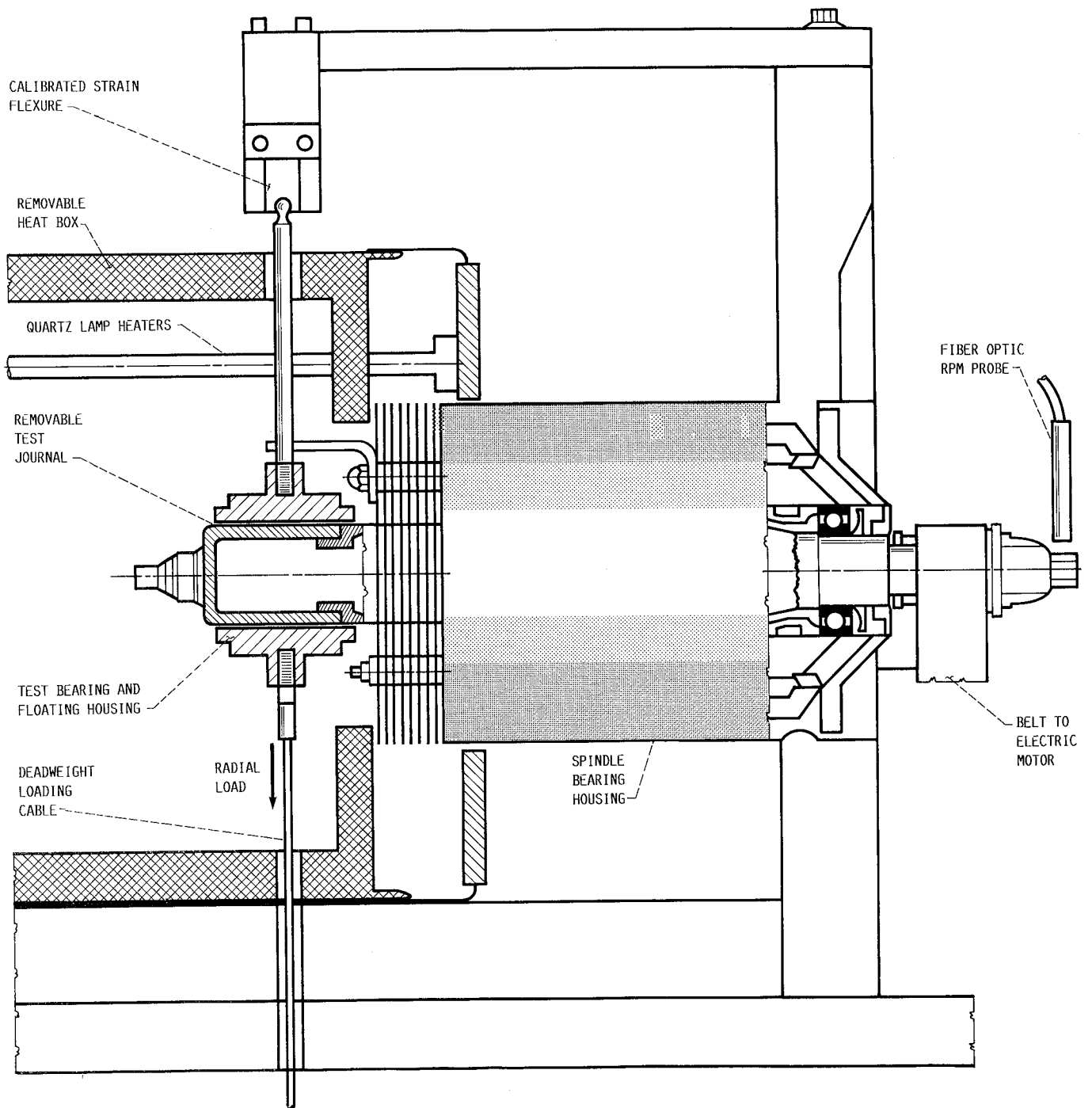

FIGURE 4. - FOIL JOURNAL BEARING MATERIALS TEST RIG.



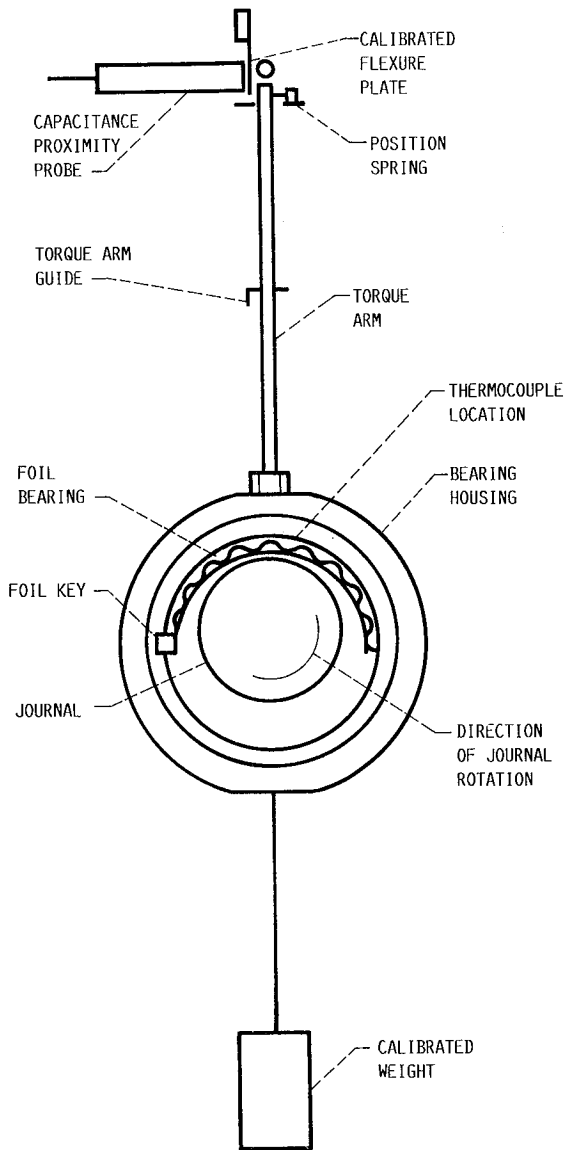

FIGURE 5. - ARRANGEMENT OF FOIL BEARING AND JOURNAL DURING TESTING.

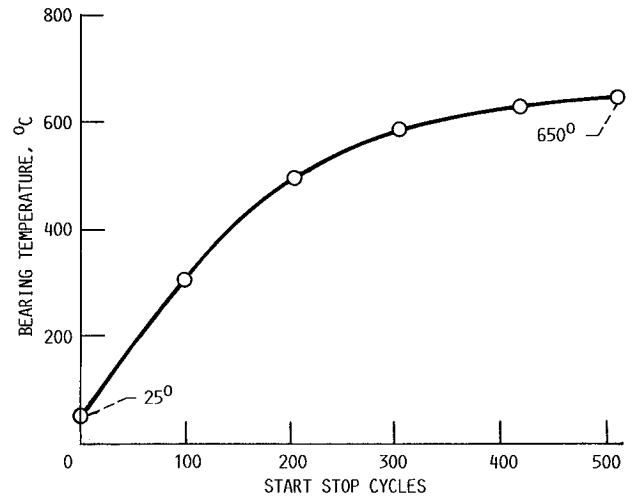

FIGURE 6. - TEST BEARING TEMPERATURE DURING 500 START/STOP CYCLES HEATING FROM 25 °C TO 650 °C.

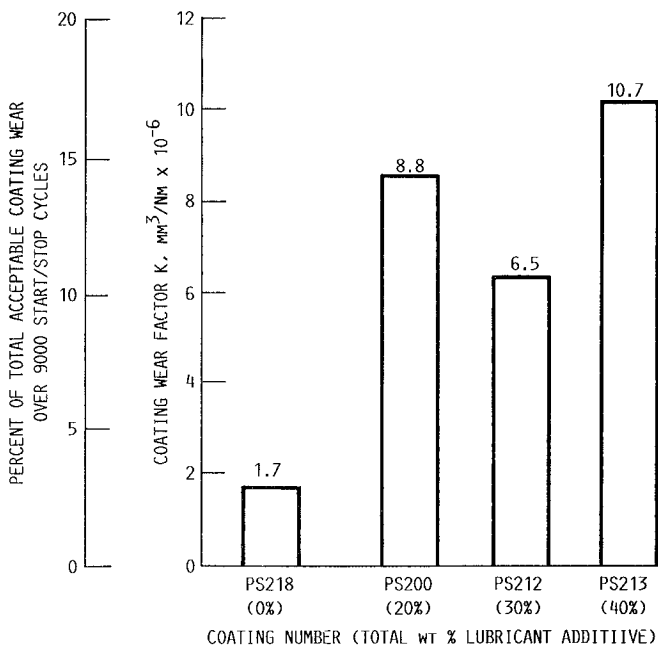

FIGURE 7. - JOURNAL COATING WEAR FACTOR, K, FOR THE VARIOUS COATING COMPOSITIONS TESTED.

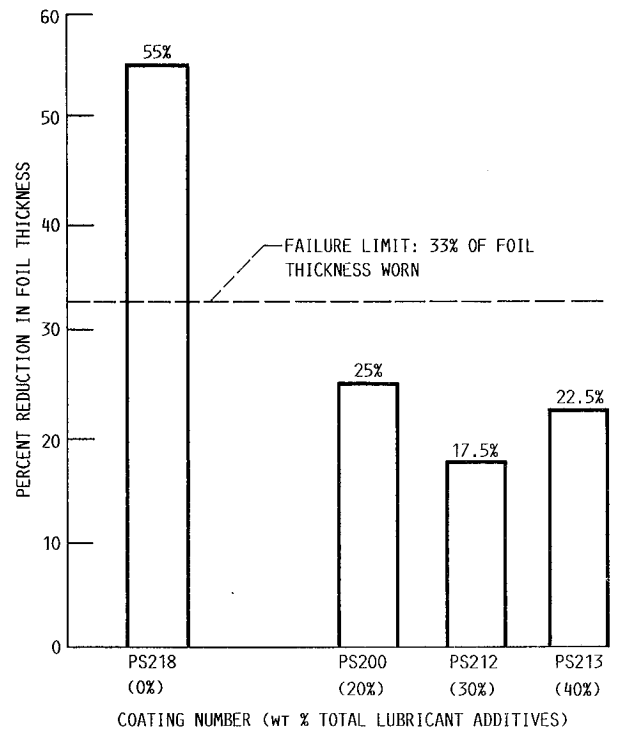

FIGURE 8. - FOIL WEAR VERSUS JOURNAL COATING COMPOSITION: TEST CONDITIONS: 9000 START/STOP CYCLES, 14 kPA LOAD.

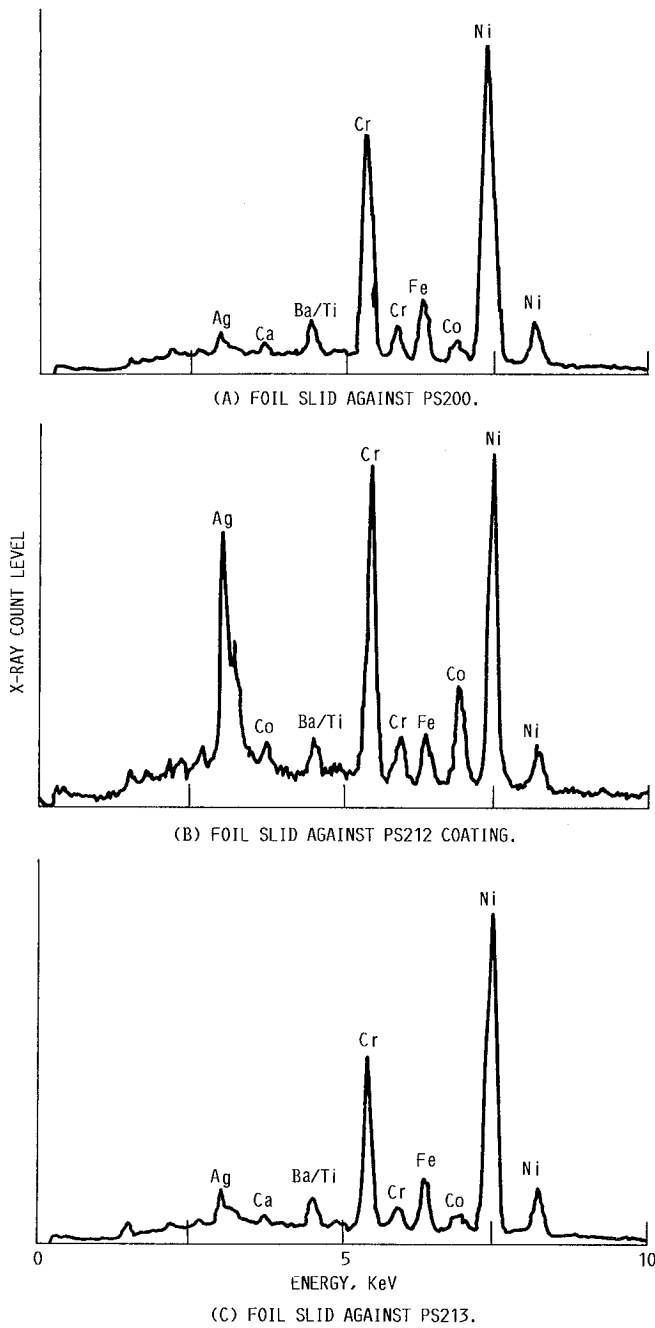

FIGURE 9. - EDAX SPECTRA FOR FOIL SURFACE AFTER SLIDING AGAINST MODIFIED COATINGS WITH LUBRICANT ADDITIVES.

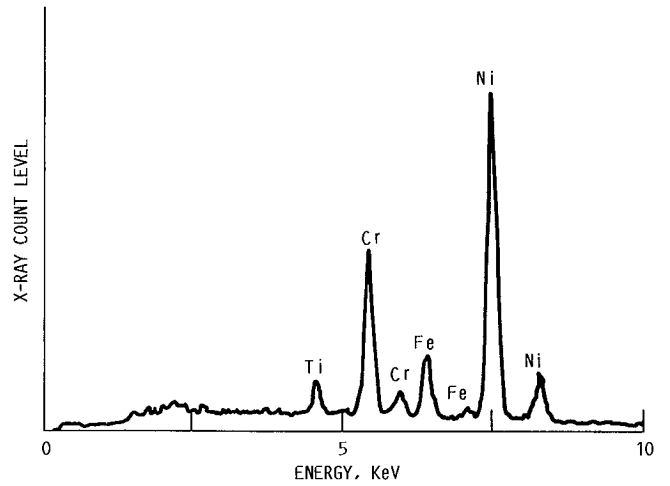

FIGURE 10. - EDAX SPECTRUM OF FOIL SURFACE AFTER SLIDING AGAINST UNMODIFIED COATING (PS218) WITH NO LUBRICANT ADDITIVES.

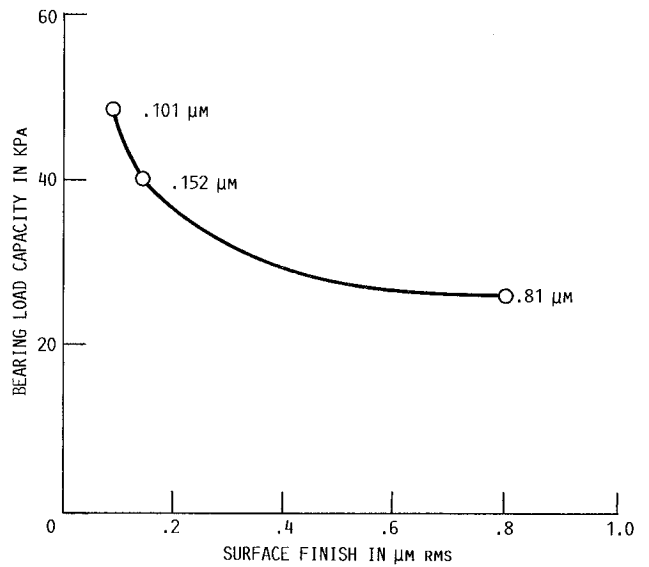

FIGURE 11. - BEARING LOAD CAPACITY VERSUS JOURNAL SURFACE FINISH. SURFACE VELOCITY 26.7 M/S AT ROOM TEMPERATURE.

1. Report No. <b>NASA CR-179649</b>		2. Government Accession No.		3. Recipient's Catalog No.	
4. Title and Subtitle <b>Composition Optimization of Chromium Carbide Based Solid Lubricant Coatings for Foil Gas Bearings at Temperatures to 650 °C</b>				5. Report Date <b>July 1987</b>	
				6. Performing Organization Code	
7. Author(s) <b>Christopher DellaCorte</b>				8. Performing Organization Report No. <b>None (E-3681)</b>	
				10. Work Unit No. <b>505-63-01</b>	
9. Performing Organization Name and Address <b>Case Western Reserve University Dept. of Mechanical and Aerospace Engineering Cleveland, Ohio 44106</b>				11. Contract or Grant No. <b>NCC 3-30</b>	
				13. Type of Report and Period Covered <b>Contractor Report Final</b>	
12. Sponsoring Agency Name and Address <b>National Aeronautics and Space Administration Lewis Research Center Cleveland, Ohio 44135</b>				14. Sponsoring Agency Code	
15. Supplementary Notes <b>Project Manager, Harold E. Sliney, Materials Division, NASA Lewis Research Center. Christopher DellaCorte, NASA Resident Research Associate.</b>					
16. Abstract <b>This paper describes a test program to determine the optimum composition of chromium carbide based solid lubricant coatings for compliant gas bearings. The coatings contain a wear resistant chromium carbide "base stock" with the lubricant additives silver and barium fluoride/calcium fluoride eutectic. The friction and wear properties of the coatings are evaluated using a foil gas bearing test apparatus. The optimum amounts of each constituent was determined in a previous study using a pin-on-disk test apparatus. The coating composition optimization is repeated in this study for air lubricated foil gas bearings from 25 to 650 °C. The various coating compositions were prepared by powder blending, then plasma sprayed onto Inconel 718 test journals and diamond ground to the desired coating thickness and surface finish. The journals were operated against preoxidized nickel-chromium alloy foils. The test bearings were subjected to repeated start/stop cycles under a 14 kPa (2 psi) bearing unit load. Sliding contact between the coated journal and smooth foil occurs during bearing start-up before lift-off or hydrodynamic lubrication by the air film is achieved and during bearing coastdown. The bearings were tested for 9000 start/stop cycles or until specimen wear reached a pre-determined failure level. In general, the addition of silver and eutectic to the chromium carbide "base stock" significantly reduced foil wear and increased journal coating wear. The optimum coating composition, PS212 (70 wt% metal bonded Cr<sub>3</sub>C<sub>2</sub>, 15 wt% Ag, 15 wt% BaF<sub>2</sub>/CaF<sub>2</sub> eutectic), reduced foil wear by a factor of two and displayed coating wear well within acceptable limits. The load capacity of the bearing using the plasma-sprayed coating prior to and after a run-in period is ascertained and compared to polished Inconel 718 specimens.</b>					
17. Key Words (Suggested by Author(s)) <b>Solid lubricant Foil bearings Ceramic tribology Plasma spray lubricant</b>			18. Distribution Statement <b>Unclassified - unlimited STAR Category 27</b>		
19. Security Classif. (of this report) <b>Unclassified</b>		20. Security Classif. (of this page) <b>Unclassified</b>		21. No of pages <b>19</b>	22. Price* <b>A02</b>