

**NASA  
Technical  
Paper  
2747**

September 1987

Piloted-Simulation Study  
of Effects of Vortex  
Flaps on Low-Speed  
Handling Qualities of  
a Delta-Wing Airplane

Jay M. Brandon,  
Philip W. Brown, and  
Alfred J. Wunschel

**NASA**

**NASA  
Technical  
Paper  
2747**

1987

Piloted-Simulation Study  
of Effects of Vortex  
Flaps on Low-Speed  
Handling Qualities of  
a Delta-Wing Airplane

Jay M. Brandon and  
Philip W. Brown

*Langley Research Center  
Hampton, Virginia*

Alfred J. Wunschel

*U.S. Air Force Systems Command  
Langley Research Center  
Hampton, Virginia*



National Aeronautics  
and Space Administration

Scientific and Technical  
Information Office

## Summary

A piloted-simulation study was conducted to investigate the effects of vortex flaps on low-speed handling qualities of a delta-wing airplane. The simulation math model was developed from wind-tunnel tests of a 0.15-scale model of the F-106B airplane. Pilot evaluations were conducted using a six-degree-of-freedom motion base simulator. The results of the investigation showed that changes in lateral-directional handling qualities due to the addition of vortex flaps were minimal; however, the reduced static longitudinal stability caused by the vortex flaps significantly degraded handling qualities in the approach-to-landing task. Acceptable handling qualities could be achieved by limiting the aft center-of-gravity location, consequently reducing the operational envelope of the airplane. Further improvements were possible by modifying the flight control force-feel system to reduce pitch-control sensitivity.

## Introduction

The vortex flap concept, illustrated in figure 1, repositions the wing leading-edge vortices such that they move from the wing onto the flap surface. The resulting induced suction pressures on the forward-facing flap produce a thrust component that reduces drag. This concept has been examined in many experimental and theoretical studies (refs. 1 to 4) and has been found to be an effective method for improving the performance of highly swept configurations at maneuver lift coefficients. As a result, considerable research has been conducted to develop analytical tools for the design of efficient and highly effective vortex flaps (refs. 5 to 7).

A flight validation effort to verify the analytical design tools and expected performance benefits for the vortex flap concept was recently initiated at the NASA Langley Research Center. The airplane chosen for the test was an F-106B. The reasons for selecting this airplane include (1) ease of structural modifications to accommodate vortex flaps, (2) compatibility of the operating envelope of the F-106B with test requirements, and (3) compatibility of the 60° delta wing with the vortex flap concept. The flight validation effort is focused primarily on verification of the design procedures employed in the design of the flaps. This verification will be accomplished with comparisons of flight, wind-tunnel, and analytically predicted pressure distributions over the wing. In addition, a limited amount of performance flight testing will be conducted to compare the relative performance of the vortex flap and basic configurations.

Wind-tunnel tests to date have shown that the addition of vortex flaps to an airplane can significantly impact its stability and control characteristics, and therefore flying qualities might also be affected. To investigate this effect, a piloted-simulation study was initiated to assess the flying qualities of the F-106B with vortex flaps over the planned test envelope. This report summarizes the results of the simulation study for the critical low-speed approach-to-landing flight phase.

## Symbols

All longitudinal data are referenced to the wind-axis system, and all lateral-directional data are referenced to the body-axis system. All force data measurements were obtained at a center-of-gravity location of 27.5 percent of the wing mean aerodynamic chord. Force coefficients for all configurations are based on the reference geometry of the basic configuration.

$b$	wing span, ft
$C_D$	drag coefficient, Drag/ $\bar{q}S$
$C_L$	lift coefficient, Lift/ $\bar{q}S$
$C_l$	rolling-moment coefficient, Rolling moment/ $\bar{q}Sb$
$\Delta C_l$	roll-control power
$C_{l_p}$	$= \frac{\partial C_l}{\partial \frac{p}{2V}}$ , per radian
$\bar{C}_{l_p}$	$= C_{l_p} + C_{l_{\dot{\beta}}} \sin \alpha$ , per radian
$C_{l_{\dot{\beta}}}$	$= \frac{\partial C_l}{\partial \dot{\beta}}$ , per degree
$C_{l_{\dot{\beta}}}$	$\frac{\partial C_l}{\partial \frac{\dot{\beta} b}{2V}}$ , per radian
$C_m$	pitching-moment coefficient, Pitching moment/ $\bar{q}S\bar{c}$
$C_{m_q}$	$= \frac{\partial C_m}{\partial \frac{q\dot{\alpha}}{2V}}$ , per radian
$\bar{C}_{m_q}$	$= C_{m_q} + C_{m_{\dot{\alpha}}}$ , per radian
$C_{m_{\dot{\alpha}}}$	$= \frac{\partial C_m}{\partial \frac{\dot{\alpha} \bar{c}}{2V}}$ , per radian
$C_n$	yawing-moment coefficient, Yawing moment/ $\bar{q}Sb$
$\Delta C_n$	yaw-control power
$C_{n_r}$	$= \frac{\partial C_n}{\partial \frac{r b}{2V}}$ , per radian
$\bar{C}_{n_r}$	$= C_{n_r} - C_{n_{\dot{\beta}}} \cos \alpha$ , per radian
$C_{n_{\dot{\beta}}}$	$= \frac{\partial C_n}{\partial \dot{\beta}}$ , per degree

$C_{n\beta}$	$= \frac{\partial C_n}{\partial \frac{\beta}{2V}}$ , per radian
$C_Y$	side-force coefficient, Side force/ $\bar{q}Sb$
$C_{Y\beta}$	$= \frac{\partial C_Y}{\partial \beta}$ , per degree
$\bar{c}$	reference mean aerodynamic chord
$g$	acceleration due to gravity ( $1g \approx 32.17 \text{ ft/sec}^2$ )
$h$	height of $\bar{c}/4$ above ground, ft
$I_{XX}, I_{YY}, I_{ZZ}$	moment of inertia about X-, Y-, and Z-axis, respectively, slug-ft <sup>2</sup>
$I_{XZ}$	product of inertia, slug-ft <sup>2</sup>
$k$	$= \frac{\text{Roll command}}{\text{Roll performance}}$
$L/D$	lift-to-drag ratio
$p$	roll rate about body X-axis, deg/sec
$q$	pitch rate about body Y-axis, deg/sec
$\bar{q}$	free-stream dynamic pressure, lb/ft <sup>2</sup>
$r$	yaw rate about Z-axis, deg/sec
$S$	reference wing area, ft <sup>2</sup>
$t$	time, sec
$V$	free-stream velocity, ft/sec
$X, Y, Z$	longitudinal, lateral, and vertical body axis, respectively
$\alpha$	angle of attack, deg
$\dot{\alpha}$	$= \frac{\partial \alpha}{\partial t}$ , rad/sec
$\beta$	angle of sideslip, deg
$\dot{\beta}$	$= \frac{\partial \beta}{\partial t}$ , rad/sec
$\Delta\beta_{\max}$	maximum change in sideslip occurring within 2 sec for a step roll-control command
$\dot{\gamma}$	flight path angle, deg
$\delta_\alpha$	antisymmetric elevon deflec- tion, deg
$\delta_e$	symmetric elevon deflection, deg

$\delta_r$	rudder deflection angle, deg
$\zeta$	damping ratio
$\psi_\beta$	phase angle of Dutch roll oscillation in sideslip
$\omega$	undamped natural frequency, rad/sec

#### Subscripts:

DR	Dutch roll
$p$	phugoid
sp	short period

#### Abbreviations:

c.g.	center of gravity
IFR	instrument flight rules (flight with no outside visual references)
PR	pilot rating
VFR	visual flight rules (flight with outside visual references)

### Airplane Description

A basic airplane configuration and vortex flap configurations were compared to assess the effects of vortex flaps on handling qualities. The basic airplane represented in the simulation study was an F-106B, which is a two-place, delta-wing, single-engine jet fighter. A three-view sketch of the basic configuration is shown in figure 2, and the mass and geometric characteristics used in the simulation are listed in table I. The primary aerodynamic controls include symmetric and antisymmetric deflection of the elevons for pitch and roll control and deflection of the rudder for yaw control. A speed brake was available to the pilot to modulate drag. The airplane is equipped with an irreversible flight control system. The control forces experienced by the pilot are provided by an artificial force-feel system that produces pitch stick and rudder pedal forces that vary with dynamic pressure. The roll-control forces, however, are invariant with flight condition. The force-feel system characteristics are shown in figure 3. The flight control system incorporates an elevon-rudder coordination feature and a stability augmentation system (SAS) consisting of pitch and yaw rate dampers (ref. 8). Normal pilot operating procedures, however, call for deactivation of the SAS during the approach-to-landing flight phase which is the primary focus of this investigation.

The vortex flap configurations were derived by the addition of constant-chord vortex flaps mounted on the basic wing leading edge at deflection angles of 30°, 40°, and 50°. (See fig. 4.) The wing leading-edge slots were sealed for the vortex flap configurations. For the purposes of this study, the effects of the flaps on airplane mass and inertia characteristics were neglected.

## Description of Simulator

The Langley Visual/Motion Simulator (VMS) is a six-degree-of-freedom motion base simulator. The VMS is equipped with a generic fighter cockpit. The flight instruments available to the pilot include angle-of-attack and sideslip indicators in addition to the normal flight instruments.

The control stick and rudder pedal force-feel characteristics were simulated to correspond to the actual airplane force-feel system. The throttle lever was of a generic design and was a serial-type control. The throttle lever on the F-106B is a parallel-type control allowing afterburner before military power; however, this difference was not significant to this study.

A closed-circuit color television system provided a visual scene of a terrain board that was displayed through a virtual image system forward of the front window. A photograph of the view from the cockpit during a landing approach is shown in figure 5.

The VMS is driven by a real-time digital simulation system and a Control Data CYBER 175 series computer system. The dynamics of the simulated airplane were calculated by using six-degree-of-freedom equations of motion at a frame rate of 32 frames per second. The equations used nonlinear aerodynamic data as functions of angle of attack, angle of sideslip, and Mach number. The data were obtained from wind-tunnel tests of scale models and included an angle-of-attack range from -3° to 51° and a sideslip range from -20° to 20°. Engine gyroscopic and airplane aeroelastic effects were not included in the mathematical model.

## Evaluation Methods

This investigation focused on the low-speed handling qualities of the study configurations at the critical approach-to-landing flight conditions. As a result, all data shown in this report correspond to those conditions unless otherwise stated. Methods used to study the effects of the vortex flaps on the stability of the airplane included interpretation of static and dynamic wind-tunnel test results, comparison of results of airplane linear stability analysis with handling qualities specifications, and piloted-simulation tests.

## Wind-Tunnel Tests

Data were obtained for the simulation study from the results of wind-tunnel tests on two models in two different facilities. The vortex flap configurations tested were a constant-chord full-span flap at three deflection angles: 30°, 40°, and 50°. (See fig. 4.) Static force and moment data were obtained with a 0.15-scale model in the Langley 30- by 60-Foot Tunnel at a dynamic pressure of 4.0 psf, which corresponds to a Reynolds number of  $1.3 \times 10^6$  based on the wing mean aerodynamic chord. Angle of attack was varied from -3° to 51° and angle of sideslip was varied from -20° to 20°. Dynamic forced-oscillation tests were also made about the roll, yaw, and pitch axes to determine dynamic stability derivatives. A limited set of ground effect data was obtained using a 0.10-scale model in the Langley 12-Foot Low-Speed Tunnel. Ground effects data were obtained for only the basic configuration and the 50° vortex flap configuration. Data obtained in the wind-tunnel tests were evaluated directly by calculating the force and moment derivatives to determine static and dynamic stability levels of the configurations over the angle-of-attack range tested. Results of the wind-tunnel tests are reported in reference 9 and will be summarized in this paper.

## Comparisons With Handling Qualities Specifications

Linearized stability and control analyses using the full nonlinear six-degree-of-freedom simulation data base were made to calculate the various response modes of the basic and vortex flap configurations. The linear analysis was conducted by operating the simulation at a given test condition and then linearizing the data for small perturbations about the test point. Predictions of response characteristics were then compared with military handling qualities specifications (MIL-F-8785C in ref. 10). In addition, open-loop response simulations using prescribed control inputs were used to investigate control effectiveness and response characteristics. These tests focused on the basic and 30° vortex flap configurations because test data (ref. 9) indicated that these configurations exhibited the highest and lowest levels of pitch stability, respectively.

## Piloted Evaluations

As stated earlier, the pilot-in-the-loop evaluations were focused on the approach-to-landing task. The piloting task consisted of an instrument approach terminating with a visual landing. Figure 6 presents a sketch of the task. The simulation was initialized on a level course offset both vertically and

laterally from the approach glide slope and localizer. This forced the pilot to maneuver both lateral-directionally and longitudinally to capture glide slope and localizer while decelerating to approach speed. The approach was flown in the simulated-instrument meteorological conditions (no outside view) using "raw" instrument data—glide slope and localizer bars. At an altitude of 250 ft, the airplane entered VFR conditions and the pilot maneuvered to a landing. Two research pilots evaluated the configurations in this study. After each approach they were asked to rate the configuration using the conventional Cooper-Harper scale (ref. 11), shown in table II, and to give any comments on their observations.

Several parameters were varied during the investigation including center-of-gravity location, vortex flap deflection angle, crosswind velocity, and turbulence level. The results of the piloted evaluations were then compared with the analytical data obtained and with MIL-F-8785C standards (ref. 10) when applicable.

## Aerodynamic Characteristics

As discussed earlier, the vortex flap concept has been shown in previous studies to enhance the performance of highly swept configurations at maneuver lift coefficients. The improvement in  $L/D$  at these conditions was also evident in the wind-tunnel data used in this study. (See ref. 9 for additional discussion.) The emphasis in the current investigation, however, was on assessing the effect of the vortex flaps on airplane handling qualities at low speeds. As a result, this section will focus only on aerodynamic stability and control characteristics.

### Static Longitudinal Stability

The longitudinal characteristics of the basic configuration with several elevon settings are presented in figure 7. The pitching-moment data indicate that the basic configuration is statically stable with a static margin of about 7 percent for the reference center-of-gravity position and maintains sufficient control power to trim beyond an angle of attack of about  $35^\circ$ . The major effect of the addition of vortex flaps on longitudinal stability was a reduction of static margin. This effect is indicated in figure 8 which summarizes the effect of vortex flap deflection angle on longitudinal stability. The data indicate that all vortex flap configurations exhibited a marked reduction in static margin compared with the basic configuration. Figure 9 presents a comparison of the static margin for the basic and  $30^\circ$  vortex flap configurations. The data show that at the nominal center-of-gravity location, the static margin of

the basic configuration is 7 percent as compared with 3 percent for the  $30^\circ$  vortex flap configuration. The reduction in longitudinal stability can be attributed to two factors: first, an addition of area due to the vortex flaps ahead of the airplane center of gravity; and second, the repositioning of the wing vortex system.

### Static Lateral-Directional Stability

The lateral-directional stability characteristics of the basic and vortex flap configurations are summarized in figure 10. The data indicate that the basic configuration remains directionally stable (positive  $C_{n\beta}$ ) to an angle of attack of  $25^\circ$ , and lateral stability remains positive (negative  $C_{l\beta}$ ) to an angle of attack of  $28^\circ$ . The effect of the vortex flap at angles of attack less than  $25^\circ$  is minimal. At higher angles of attack, the vortex flaps significantly augment static lateral-directional stability. The effect of the vortex flaps on control effectiveness is presented in figures 11 and 12. Figure 11 shows the control moments available using full roll-control inputs for the basic and vortex flap configurations. The data show that the roll-control power is not significantly affected by vortex flaps at angles of attack below  $30^\circ$ . Figure 12 shows that the vortex flaps do not significantly affect the rudder control power in yaw at angles of attack below  $35^\circ$ . An increased amount of rolling moment due to rudder deflection was produced for angles of attack less than  $30^\circ$  compared with the basic configuration—particularly with the  $30^\circ$  vortex flap configuration. The data indicate no lateral-directional stability problems in the angle-of-attack range of interest in the approach-to-landing flight phase.

### Dynamic Stability

Dynamic stability data were obtained using a conventional forced-oscillation technique (ref. 12). The results of these tests are summarized for the primary damping derivatives  $\bar{C}_{mq}$ ,  $\bar{C}_{lp}$ , and  $\bar{C}_{nr}$  in figures 13, 14, and 15, respectively. Although the data show some effect of the vortex flaps on these parameters at higher angles of attack, there are no significant effects at the angles of attack of interest to this study ( $\alpha < 22^\circ$ ).

### Ground Effect

The effect of proximity to the ground was investigated for the basic and  $50^\circ$  vortex flap configurations. The longitudinal data obtained in the study were used in the simulation. Figure 16 shows the results for the basic configuration. The data indicate a slight increase in lift due to ground effect at angles of attack greater than  $8^\circ$ . The pitching-moment

data show a corresponding increment of nose-down pitching moment due to ground effect. This indicates that the center of pressure of the added lift due to ground effect is behind the center of gravity. At angles of attack less than 8 to 10°, the lift is reduced in ground effect. The pitching-moment data show an increased nose-up pitching moment due to ground effect at low angles of attack, and therefore the "suck-down" effect in lift due to ground effect would not be expected to create a problem in rotating the airplane to a lift-off attitude. Figure 17 shows the effect of ground proximity on the 50° vortex flap configuration. Similar trends are seen as discussed for the basic configuration; however, the magnitude of the ground effects is less for the 50° flap configuration.

## Non-Piloted Simulation Results

Analytical studies using the simulation data base were conducted to evaluate the stability and control characteristics of the basic and vortex flap configurations at approach-to-landing conditions. The classic stability and control parameters were calculated for the flight conditions shown in table III and were compared with values listed in reference 10 corresponding to desirable handling qualities.

### Longitudinal Stability

Longitudinal stability characteristics were calculated using linearized analysis methods described in reference 10. Flight path stability during the approach-to-landing condition for the basic and 30° vortex flap configurations is presented in figure 18. The figure shows the flight path angle as a function of velocity. The data were calculated by setting initial conditions on a 3° glide slope at a nominal approach speed of 180 knots. The velocity was then varied through pitch-control inputs without changing the power level. The results show that the basic configuration is slightly unstable at the normal approach speed of 180 knots. This indicates that the basic configuration is operating on the backside of the power curve at the approach flight condition. Guidelines for the amount of flight path instability allowable during the approach are published in reference 10. The maximum unstable slope for level 1 flying qualities (table II) is indicated in figure 18. The results show that characteristics of the basic configuration fall within the acceptable range. The 30° vortex flap configuration shows flight path stability at 180 knots, an indication that it is operating on the front side of the power curve.

Values of the frequency and damping ratio of the short-period and phugoid oscillation modes were also

calculated. Results for the basic and vortex flap configurations are summarized in figures 19 to 21. The data in figure 19 show a decrease in short-period frequency due to the addition of vortex flaps. This effect is due primarily to the decrease in static stability with the addition of the flaps as discussed earlier. This characteristic is also primarily responsible for the significant increase in damping ratio as shown in figure 20. Figure 21 summarizes the effect of the center-of-gravity location on the phugoid damping ratio for the basic and vortex flap configurations. The results are compared with values from reference 10, and all values fall well within the range of acceptable handling quality criteria. It is interesting to note the rapid increase in damping ratio at the aft c.g. range for the vortex flap configurations. The observed "jump" in the damping ratio occurs at the point where the short-period mode becomes nonoscillatory.

An important consideration in the handling quality evaluation of a configuration is the sensitivity of the controls. Excessive pitch-control sensitivity, combined with low static stability levels, can make an airplane prone to pilot-induced oscillations and over-control. Figure 22 summarizes the pitch-control sensitivity for a range of center-of-gravity locations for the test configurations. The data show an increase in pitch sensitivity due to the addition of the vortex flaps and due to aft movement of the center of gravity. The data are compared with values given in reference 10 corresponding to three levels of handling qualities. The data show that the stick-force-per-*g* values for the basic configuration are in the satisfactory region over the entire center-of-gravity range, whereas the values for vortex flap configurations are in the unsatisfactory region over much of the center-of-gravity range. The most sensitive configuration over most of the center-of-gravity range is the 30° vortex flap configuration which does not meet the sensitivity levels for satisfactory handling qualities at any point in the c.g. range.

The major factor causing the increased pitch-control sensitivity of the vortex flap configurations is the reduction of static stability discussed earlier. However, it should be noted that even at comparable levels of static stability, the vortex flap configurations maintain a higher level of pitch-control sensitivity than the basic configuration. This characteristic can be seen, for example, by comparing results at center-of-gravity locations of 24 percent  $\bar{c}$  for the 30° vortex flap configuration and 28 percent  $\bar{c}$  for the basic configuration. In these cases, the higher control sensitivity for the vortex flap airplane is primarily due to the increased elevon moment arm resulting from the forward c.g. movement. The longer moment

arm gives increased pitch-control effectiveness and results in higher levels of pitch-control sensitivity when compared with the basic configuration at the same level of static stability.

### Lateral-Directional Stability

Lateral-directional stability characteristics of the study configurations were investigated in a manner similar to that employed in the previous longitudinal study. Linear stability analysis was used to calculate values of Dutch roll frequency, damping ratio, and the roll and spiral mode time constants.

The Dutch roll characteristics obtained for the basic and vortex flap configurations are presented in table IV. A comparison with the criteria of reference 10 shown in table V indicates that all the study configurations exhibit desirable (level 1) Dutch roll frequency and damping.

The criteria for spiral stability, as shown in reference 10, specify that following a disturbance in roll angle, the time for the roll angle to double amplitude shall be greater than 12 sec for level 1 flying qualities. The analysis showed that both the basic and vortex flap configurations were spirally stable and tended to reduce the roll angle after a disturbance, although the addition of the vortex flaps decreased the level of stability. The calculated time to reach half-amplitude for the basic and 30° vortex flap configurations is presented in figure 23 as a function of center-of-gravity location.

Roll response characteristics were calculated for the basic and vortex flap configurations. Figure 24 presents time history data of an abrupt input of one-half the available antisymmetric elevon control deflection applied at the approach flight condition. The resulting roll rate for the basic configuration was significantly greater than that for the 30° vortex flap configuration. These differences in roll response between the basic and vortex flap configurations are due to aerodynamic roll damping and rudder characteristics. The roll rate damping of the vortex flap configurations is slightly greater than that of the basic configuration (fig. 14), and in addition the rolling moment due to rudder deflection is more adverse (fig. 12). Because of the elevon-rudder interconnect feature in the control system, the rudder is deflected with the antisymmetric elevon deflection, thus producing a rolling moment from the rudder deflection that opposes the rolling moment produced by the antisymmetric elevon deflection. Values of the sideslip excursion parameter  $\Delta\beta_{\max}/k$  for the two configurations are presented in figure 25 and compared with the handling quality criteria of reference 10. The results

indicate that the control of sideslip excursions during roll maneuvers is satisfactory for both configurations.

### Pilot Evaluations

Pilot evaluations were conducted to assess the closed-loop stability and handling qualities of the basic and vortex flap configurations. The pilot evaluations concentrated on the approach-to-landing task in simulated-instrument meteorological conditions as described previously. This task required the two pilots (A and B) involved in the study to maneuver both laterally and longitudinally to capture glide slope and localizer. Simulated approaches were conducted for the basic and 30° vortex flap configurations. A less comprehensive test matrix was evaluated with the 40° and 50° vortex flap configurations.

#### Effect of Center-of-Gravity Location

As previously shown, the major effect of incorporating the vortex flap is a reduction in pitch stability combined with an increase in control sensitivity. Studies indicated that at the nominal c.g. location of 28 percent  $\bar{c}$ , the basic configuration exhibited the most favorable handling qualities followed by the 50°, 40°, and 30° vortex flap configurations in order of increasingly degraded controllability. This trend is shown in figure 26 in terms of the Cooper-Harper rating scale. The best and worst configurations, the basic and 30° vortex flap configurations, respectively, were investigated further to determine the effect of center-of-gravity location on flight characteristics. Figure 27 summarizes the test results for the two configurations over a center-of-gravity range from 24 percent  $\bar{c}$  to 32 percent  $\bar{c}$ . Figure 27(a) presents the pilot ratings for the approach task with the basic configuration. The ratings indicate that the basic configuration was judged to have fairly good handling qualities at all center-of-gravity locations except at 26 percent  $\bar{c}$ . The degraded pilot rating for the airplane with the c.g. at 26 percent  $\bar{c}$  was a result of the increased difficulty that the pilots experienced in maintaining precision control in pitch. Pitch oscillations were observed which required considerable pilot compensation to make an adequate approach.

Figure 27(b) presents the results with the 30° vortex flap configuration. The pilot ratings show good agreement between the two pilots and clearly indicate a degradation in handling qualities when compared with the basic configuration. The results show that satisfactory characteristics (level 1) were not achieved at any c.g. location; however, adequate performance was obtainable at center-of-gravity locations at and ahead of 28 percent  $\bar{c}$ . As expected,



based on the wind-tunnel results discussed earlier, the lower pilot ratings for the vortex flap configurations were due primarily to degraded pitch characteristics; no significant differences in lateral-directional handling qualities were noted between any of the study configurations. With the vortex flaps, the pitch attitude and vertical speed were difficult to maintain at constant values during the approach. This characteristic was aggravated as the center-of-gravity location was moved aft. It was also found that during a maneuver to capture the localizer, a roll input would cause a pitch disturbance that increased the pilot work load. This nose-up characteristic was observed in both the basic and vortex flap configurations but was much more pronounced for the latter. The nose-up disturbance during a roll was found to be a result of increased elevon effectiveness in a trailing-edge-up sense such that a symmetric differential deflection for aileron control produced a slight nose-up pitching moment.

### Control System Modifications

As previously discussed, the 30° vortex flap configuration is less statically stable in pitch than the basic configuration. It is interesting to note that even at center-of-gravity locations at which the same level of stability exists, a discrepancy is still present in ratings between the configurations. For example, with a center-of-gravity location of 32 percent  $\bar{c}$ , the basic configuration was rated to have satisfactory flying qualities (PR = 3). With the c.g. at 28 percent  $\bar{c}$  to achieve the same level of stability, the vortex flap configuration was rated to have significantly poorer characteristics (PR = 5). This difference is attributable to the much higher pitch-control sensitivity of the vortex flap configuration discussed earlier (fig. 22) which caused overcontrol and pilot-induced oscillations during the simulated approaches.

One approach for addressing this problem is to increase the stick force gradient and therefore the stick-force-per- $g$  values. The control system of the F-106B airplane varies the pitch stick force gradient as a function of dynamic pressure during flight. To investigate the effect of decreasing the pitch-control sensitivity for the 30° vortex flap configuration, a bias in dynamic pressure (designated as " $\bar{q}$ -bias") was added to the control system to increase the pitch stick force gradient at low-speed flight conditions. The bias was selected such that the resulting control sensitivity would be equivalent to that of the basic configuration with comparable levels of static margin. Figure 28 shows the pitch-control sensitivity for the two configurations across the center-of-gravity range after the bias was added to the vortex flap configuration. The results of the piloted-simulation studies

are summarized in figure 29. The data show that artificially reducing the pitch-control sensitivity enhanced the handling qualities of the configuration to the extent that an improvement of approximately 1 pilot rating point was obtained on the Cooper-Harper rating scale. The results indicate that restricting the c.g. to 28 percent  $\bar{c}$  combined with increasing the force-feel gradient at low speeds provides the vortex flap configuration with flying qualities approaching those of the basic airplane.

### Wind and Turbulence

The effects of wind and turbulence were investigated primarily on the basic and 30° vortex flap configurations at several center-of-gravity locations. Approaches with crosswind components up to 20 knots were conducted. The effect of crosswind below 10 knots was very minimal in terms of pilot rating for both configurations. At 20 knots, the crosswind component became a significant factor and degraded the pilot ratings by about 2 points on the Cooper-Harper scale because of difficulties in the flare portion of the landing.

The turbulence model employed by the simulation was the standard Dryden turbulence model (refs. 13 and 14). Random turbulence in the three axes was input at light and moderate levels. Turbulence at these levels was not found to degrade the handling qualities of the configurations significantly during the approach, but some degradation was evident during the flare segment for configurations with reduced longitudinal stability.

### Conclusions

A piloted-simulation investigation was conducted to study the effect of vortex flaps on the low-speed handling qualities of a delta-wing airplane. The results can be summarized as follows:

1. The reduction in pitch stability from about 7 percent to 3 percent stable static margin associated with the installation of the vortex flaps degraded the handling qualities of the airplane in the approach-to-landing task by increasing the difficulty in controlling pitch attitude and rate of descent.
2. Acceptable handling qualities can be achieved for the vortex flap configurations by limiting the aft center-of-gravity location to 28 percent of the mean aerodynamic chord. Further improvement can be obtained by modifying the flight control force-feel system to reduce pitch-control sensitivity.

3. Changes in lateral-directional handling characteristics due to the addition of vortex flaps were minimal.

4. The addition of vortex flaps did not significantly affect the characteristics of the airplane in ground effect.

NASA Langley Research Center  
Hampton, Virginia 23665-5225  
July 29, 1987

## References

1. Rao, Dhanvada M.: *Leading Edge Vortex-Flap Experiments on a 74 Deg. Delta Wing*. NASA CR-159161, 1979.
2. Hallissy, James B.; Frink, Neal T.; and Huffman, Jarrett K.: Aerodynamic Testing and Analysis of Vortex Flap Configurations for the 5-Percent Scale F-106B. *Vortex Flow Aerodynamics, Volume II*, James F. Campbell, Russell F. Osborn, and Jerome T. Foughner, Jr., eds., NASA CP-2417, 1986, pp. 227-248.
3. Yip, Long P.: Investigation of Vortex Flaps on the F-106B Airplane Configuration in the 30- by 60-Foot Wind Tunnel. *Vortex Flow Aerodynamics, Volume II*, James F. Campbell, Russell F. Osborn, and Jerome T. Foughner, Jr., eds., NASA CP-2417, 1986, pp. 201-226.
4. Erickson, Gary E.: Application of Free Vortex Sheet Theory to Slender Wings With Leading-Edge Vortex Flaps. AIAA-83-1813, July 1983.
5. Lamar, John E.: Subsonic Vortex-Flow Design Study for Slender Wings. *J. Aircr.*, vol. 15, no. 9, Sept. 1978, pp. 611-617.
6. Frink, Neal T.: *Concept for Designing Vortex Flap Geometries*. NASA TP-2233, 1983.
7. Lan, C. Edward; and Hsing, C. C.: Subsonic Analysis and Design of Vortex Flaps. *Vortex Flow Aerodynamics, Volume II*, James F. Campbell, Russell F. Osborn, and Jerome T. Foughner, Jr., eds., NASA CP-2417, 1986, pp. 97-110.
8. Teper, Gary L.: *Aircraft Stability and Control Data*. Contract NAS2-4478, Systems Technology, Inc., Apr. 1969. (Available as NASA CR-96008.)
9. Yip, Long P.: *Wind-Tunnel Free-Flight Investigation of a 0.15-Scale Model of the F-106B Airplane With Vortex Flaps*. NASA TP-2700, 1987.
10. *Military Specification—Flying Qualities of Piloted Airplanes*. MIL-F-8785C, Nov. 5, 1980. (Supersedes MIL-F-8785B, Aug. 7, 1969.)
11. Cooper, George E.; and Harper, Robert P., Jr.: *The Use of Pilot Rating in the Evaluation of Aircraft Handling Qualities*. NASA TN D-5153, 1969.
12. Chambers, Joseph R.; and Grafton, Sue B.: *Investigation of Lateral-Directional Dynamic Stability of a Tilt-Wing V/STOL Transport*. NASA TN D-5637, 1970.
13. Taylor, James: *Manual on Aircraft Loads*. AGARD-ograph 83, Pergamon Press Inc., c.1965.
14. Houbolt, John C.; Steiner, Roy; and Pratt, Kermit G.: *Dynamic Response of Airplanes to Atmospheric Turbulence Including Flight Data on Input and Response*. NASA TR R-199, 1964.

Table I. Mass and Dimensional Characteristics of Simulated Airplane

Weight, lb . . . . .	27 400
Moment of inertia:	
$I_{XX}$ , slug-ft <sup>2</sup> . . . . .	15 983
$I_{YY}$ , slug-ft <sup>2</sup> . . . . .	174 383
$I_{ZZ}$ , slug-ft <sup>2</sup> . . . . .	184 002
$I_{XZ}$ , slug-ft <sup>2</sup> . . . . .	5971
Wing:	
Span, ft . . . . .	38.29
Area, ft <sup>2</sup> . . . . .	695
Mean aerodynamic chord, ft . . . . .	23.76

Table II. Cooper-Harper Pilot Opinion Rating Scale Taken From Reference 11

CHARACTERISTICS	DEMANDS ON THE PILOT IN SELECTED TASK OR REQUIRED OPERATION	PILOT RATING	FLYING QUALITY LEVELS*
Excellent, highly desirable	Pilot compensation not a factor for desired performance	1	1
Good, negligible deficiencies	Pilot compensation not a factor for desired performance	2	
Fair--some mildly unpleasant deficiencies	Minimal pilot compensation required for desired performance	3	
Minor but annoying deficiencies	Desired performance requires moderate pilot compensation	4	2
Moderately objectionable deficiencies	Adequate performance requires considerable pilot compensation	5	
Very objectionable but tolerable deficiencies	Adequate performance requires extensive pilot compensation	6	
Major deficiencies	Adequate performance not attainable with maximum tolerable pilot compensation. Controllability not in question.	7	3
Major deficiencies	Considerable pilot compensation is required for control	8	
Major deficiencies	Intense pilot compensation is required to retain control	9	
Major deficiencies	Control will be lost during some portion of required operation	10	

ADEQUACY FOR SELECTED TASK OR REQUIRED OPERATION

Yes

Is it satisfactory without improvement?

No

Deficiencies warrant improvement

Yes

Is adequate performance obtainable with a tolerable pilot work load?

No

Deficiencies require improvement

Yes

Is it controllable?

No

Improvement mandatory

PILOT DECISIONS

\*Flying quality levels defined in reference 10.

Table III. Approach-to-Landing Flight Conditions

[Landing gear down; speed brakes out; c.g. = 28 percent  $\bar{c}$ ; Weight = 27 400 lb]

Flight condition	Configuration			
	Basic	30° vortex flap	40° vortex flap	50° vortex flap
Velocity, knots . . . . .	180	180	180	180
$\gamma$ , deg . . . . .	-3	-3	-3	-3
$\alpha$ , deg . . . . .	11.3	10.6	10.8	11.2
$\delta_e$ , deg . . . . .	-4.13	-2.42	-3.05	-2.54
Thrust, lb . . . . .	6410	5792	5925	5518

Table IV. Summary of Dutch Roll Characteristics of Test Configurations

Center-of-gravity location, percent $\bar{c}$	Basic		30° vortex flap		40° vortex flap		50° vortex flap	
	$\omega_{DR}$ , rad/sec	$\zeta_{DR}$	$\omega_{DR}$ , rad/sec	$\zeta_{DR}$	$\omega_{DR}$ , rad/sec	$\zeta_{DR}$	$\omega_{DR}$ , rad/sec	$\zeta_{DR}$
24	2.11	0.215	1.88	0.282	2.03	0.262	2.13	0.245
26	2.07	.205	1.85	.267	1.99	.255	2.11	.234
28	2.03	.193	1.83	.251	1.94	.249	2.09	.224
30.5	2.00	.175	1.80	.239	1.88	.244	2.07	.210

Table V. Minimum Dutch Roll Frequency and Damping as Specified in Reference 10

Flying quality level	Minimum values of—		
	$\zeta_{DR}$	$\omega_{DR}$ , rad/sec	$\omega_{DR}$ , rad/sec
1	0.08	0.15	1.0
2	.02	.05	.4
3	0		.4

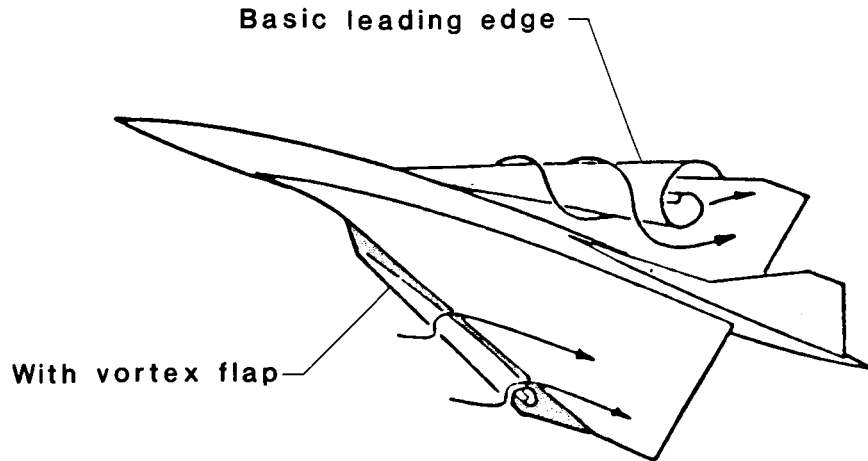

Figure 1. Vortex flap concept.

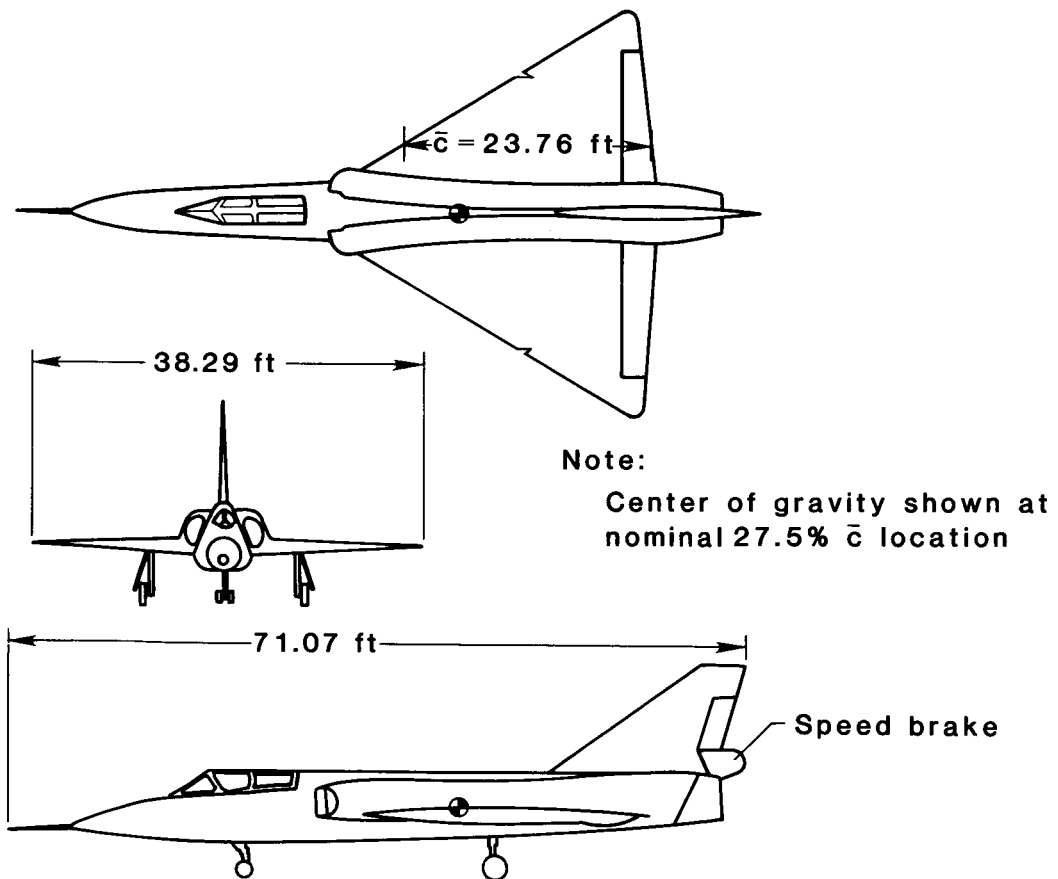
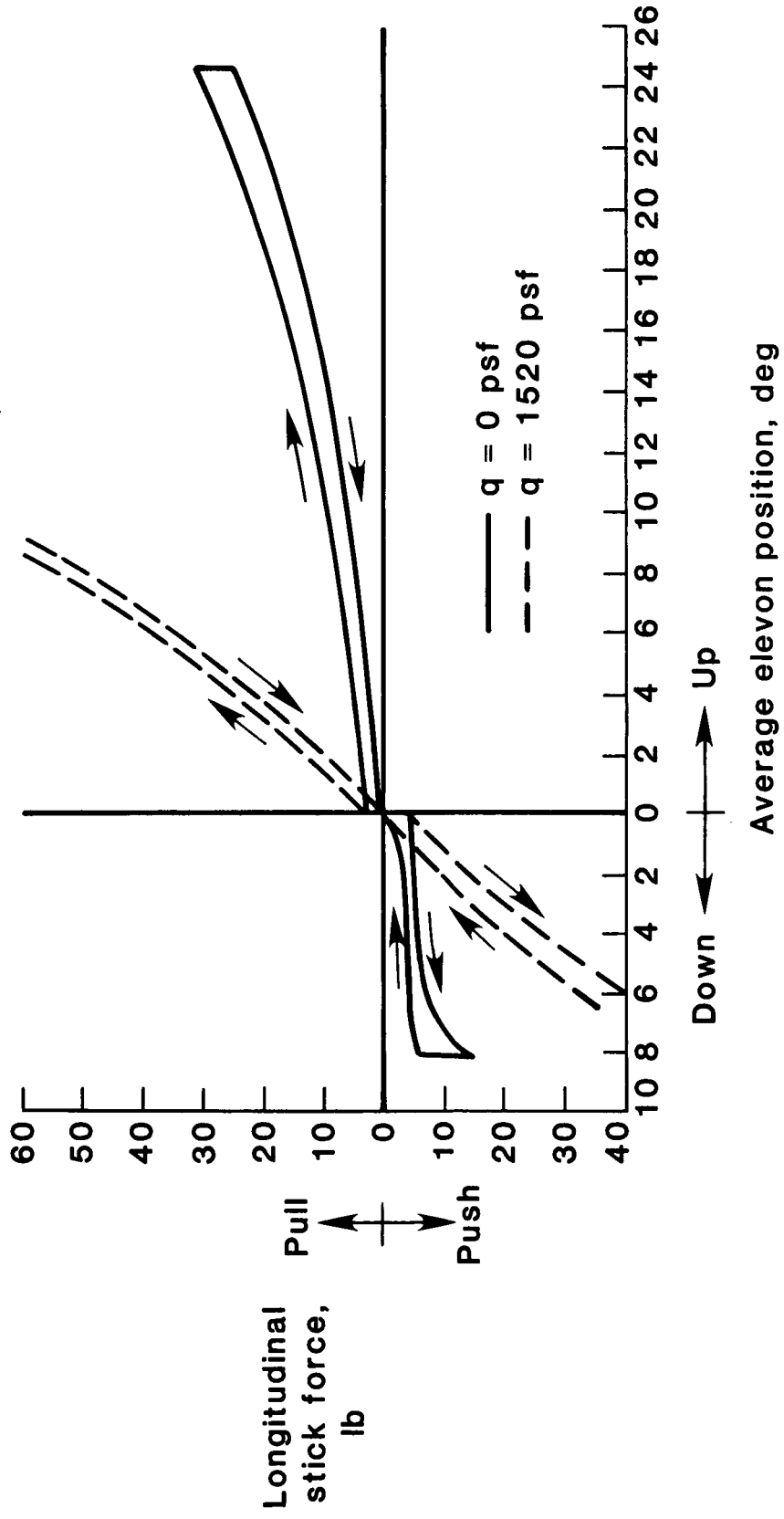
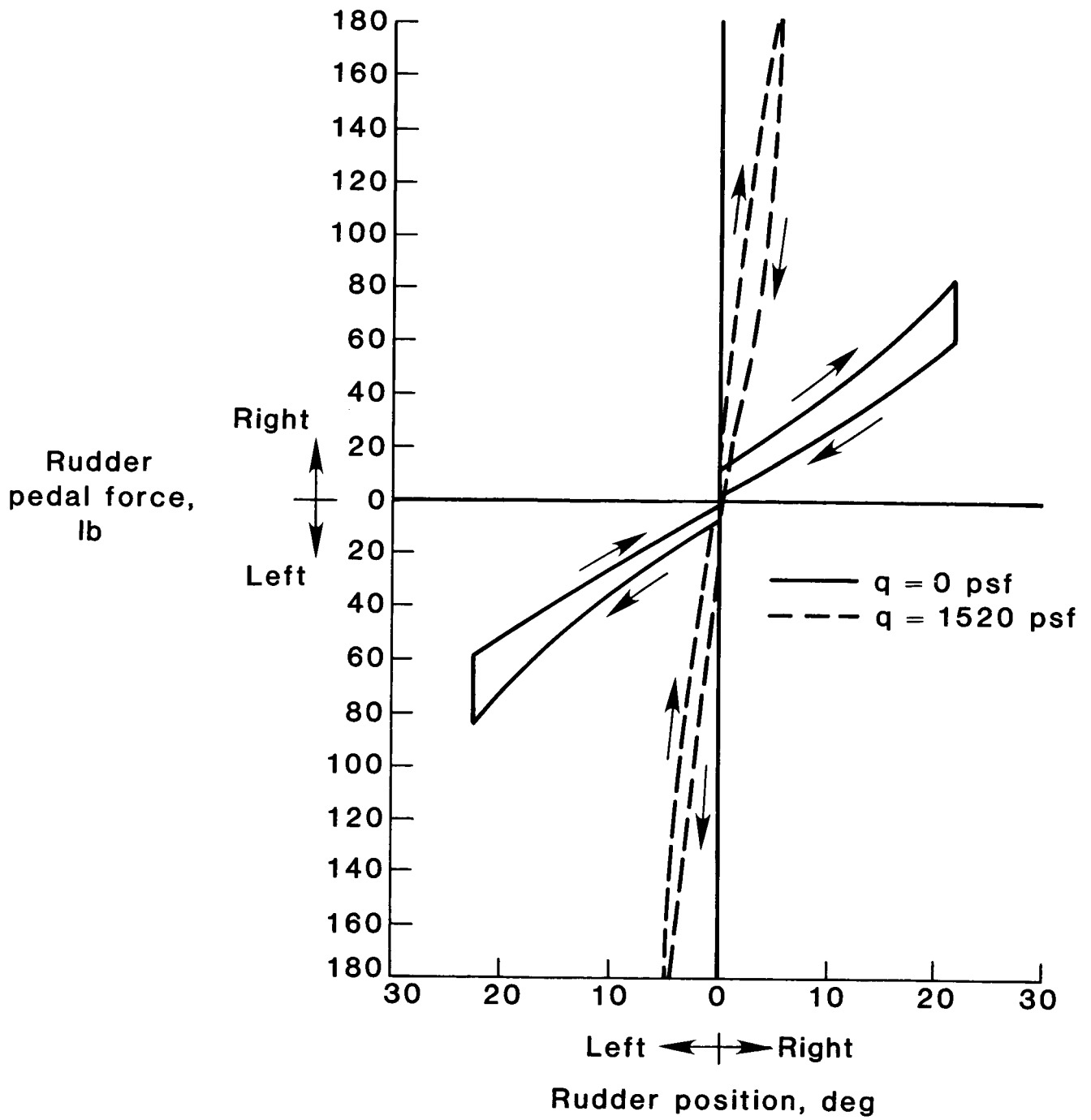

Figure 2. Drawing of basic configuration.



(a) Longitudinal characteristics.  
 Figure 3. Force-feel system characteristics.



(b) Directional characteristics.

Figure 3. Continued.



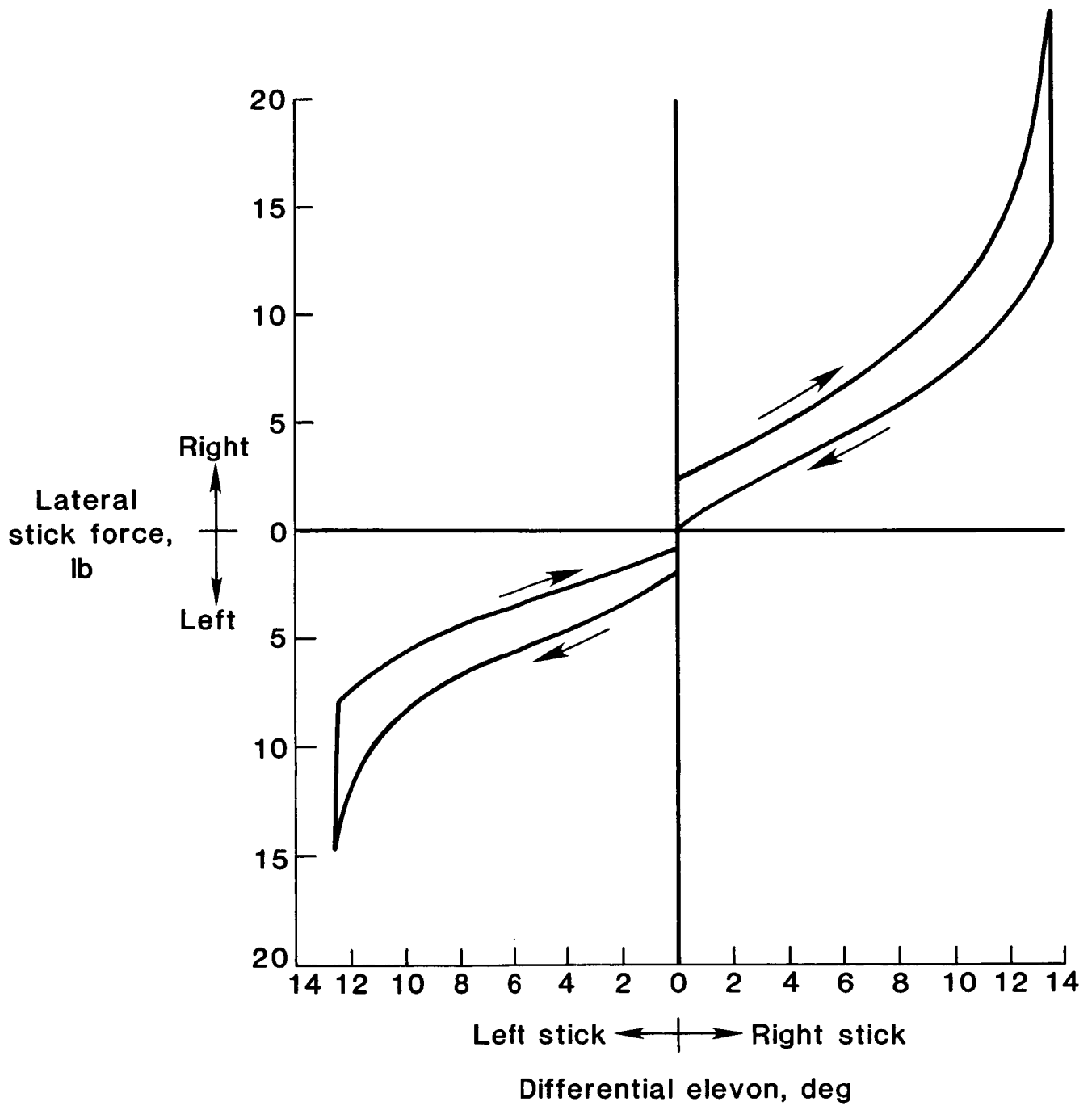

(c) Lateral characteristics.

Figure 3. Concluded.

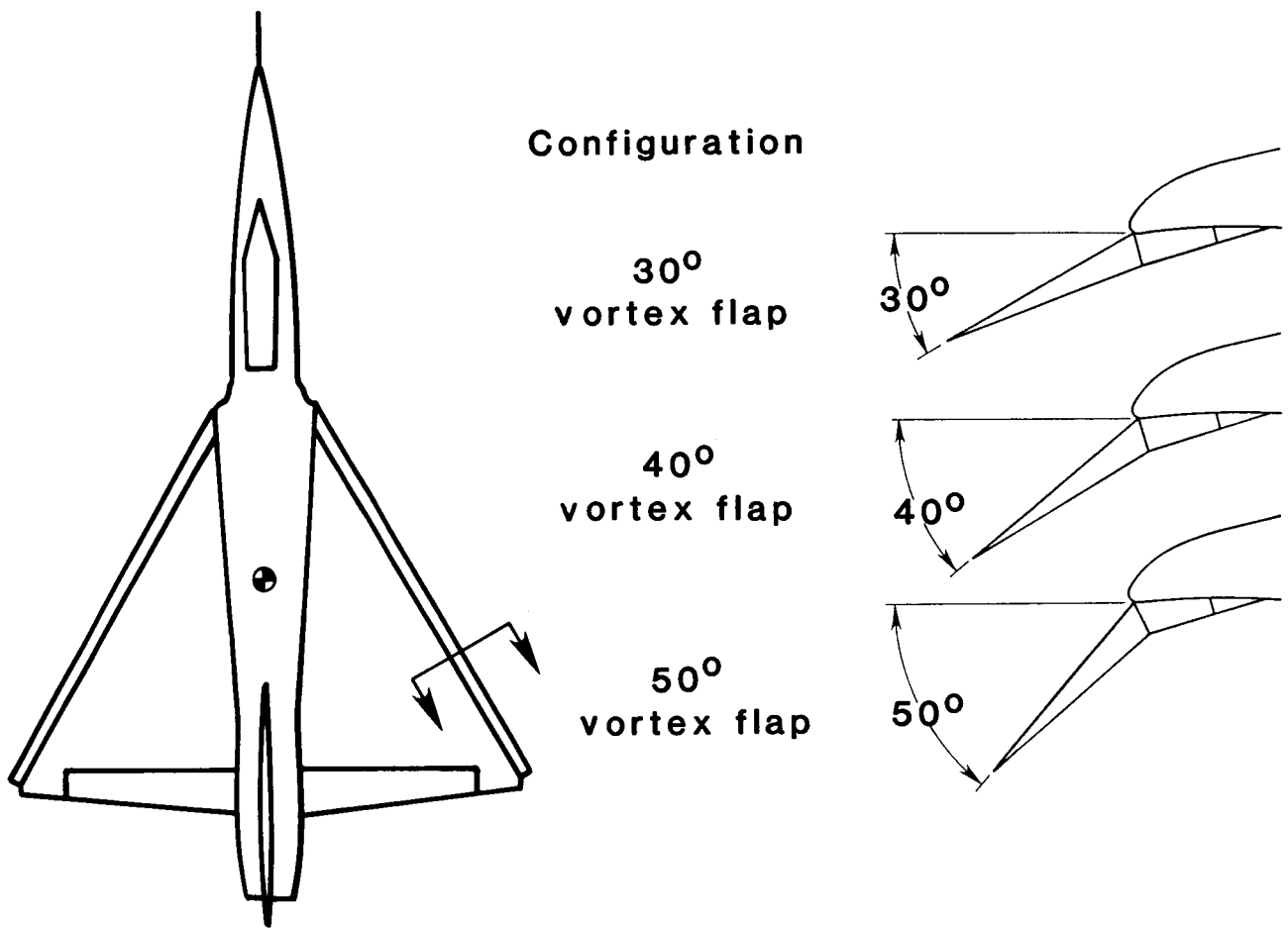
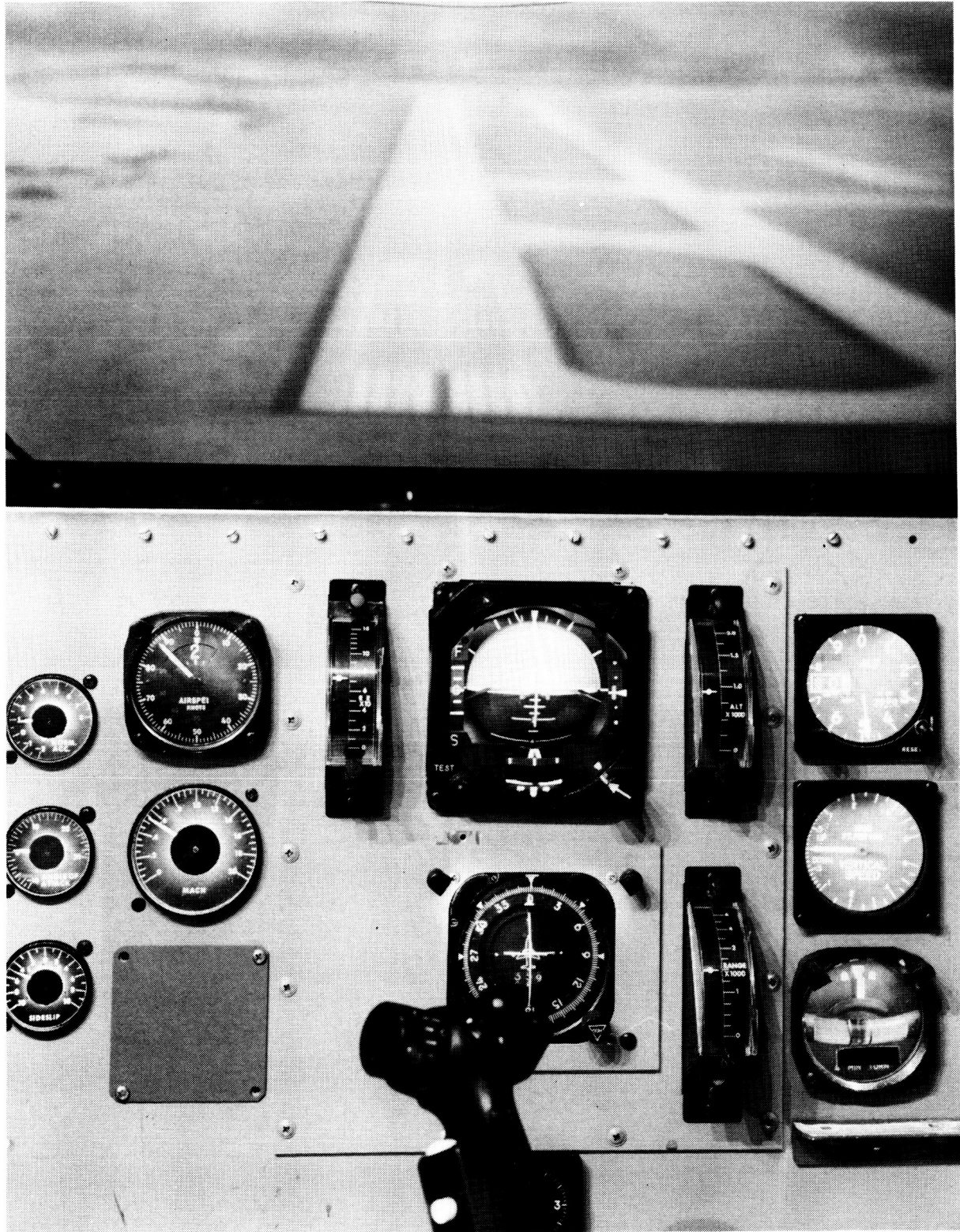

Figure 4. Sketch of vortex flap configurations tested.

ORIGINAL PAGE IS  
OF POOR QUALITY



L-86-4010

Figure 5. View from cockpit during final approach.

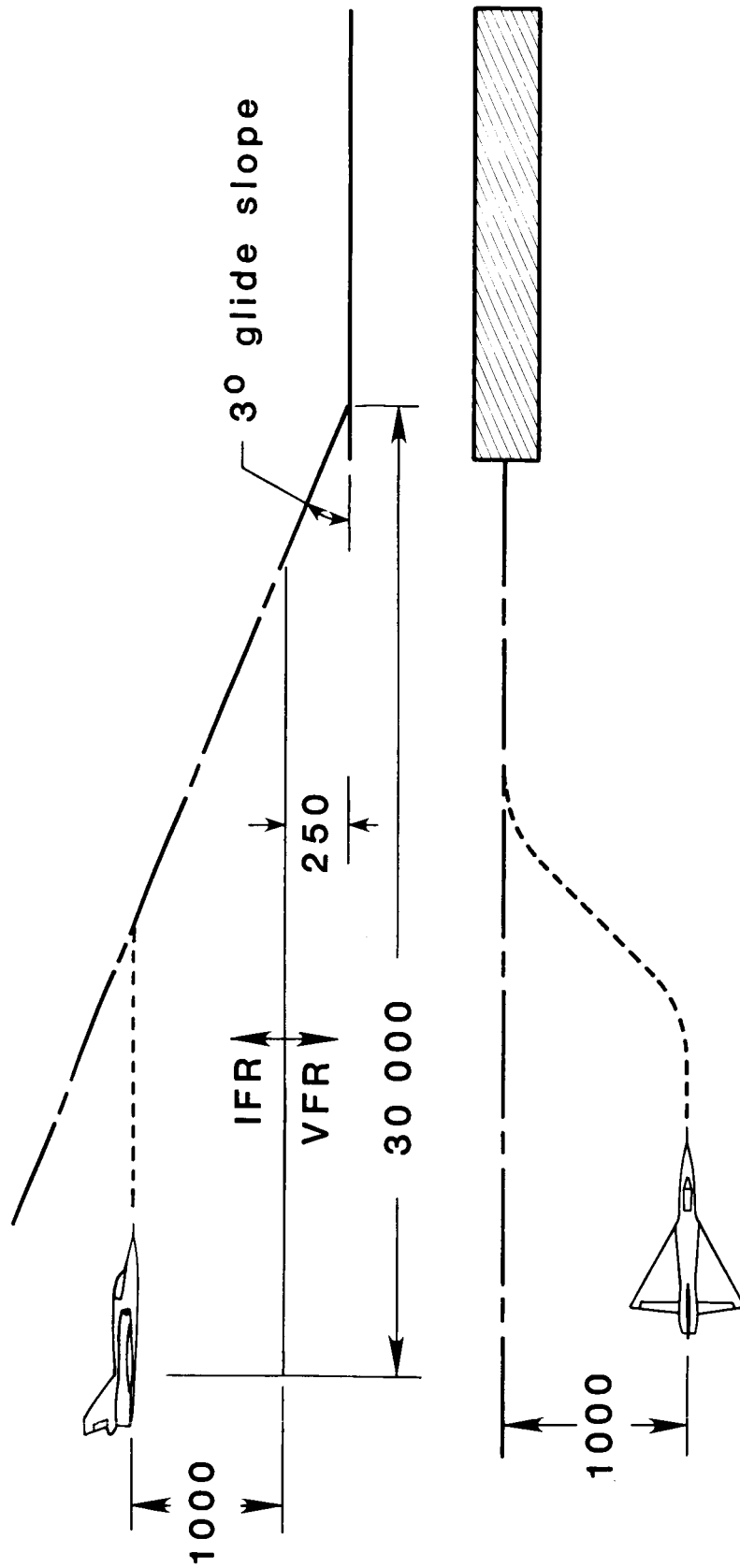

Figure 6. Approach-to-landing task. Linear dimensions are given in feet.

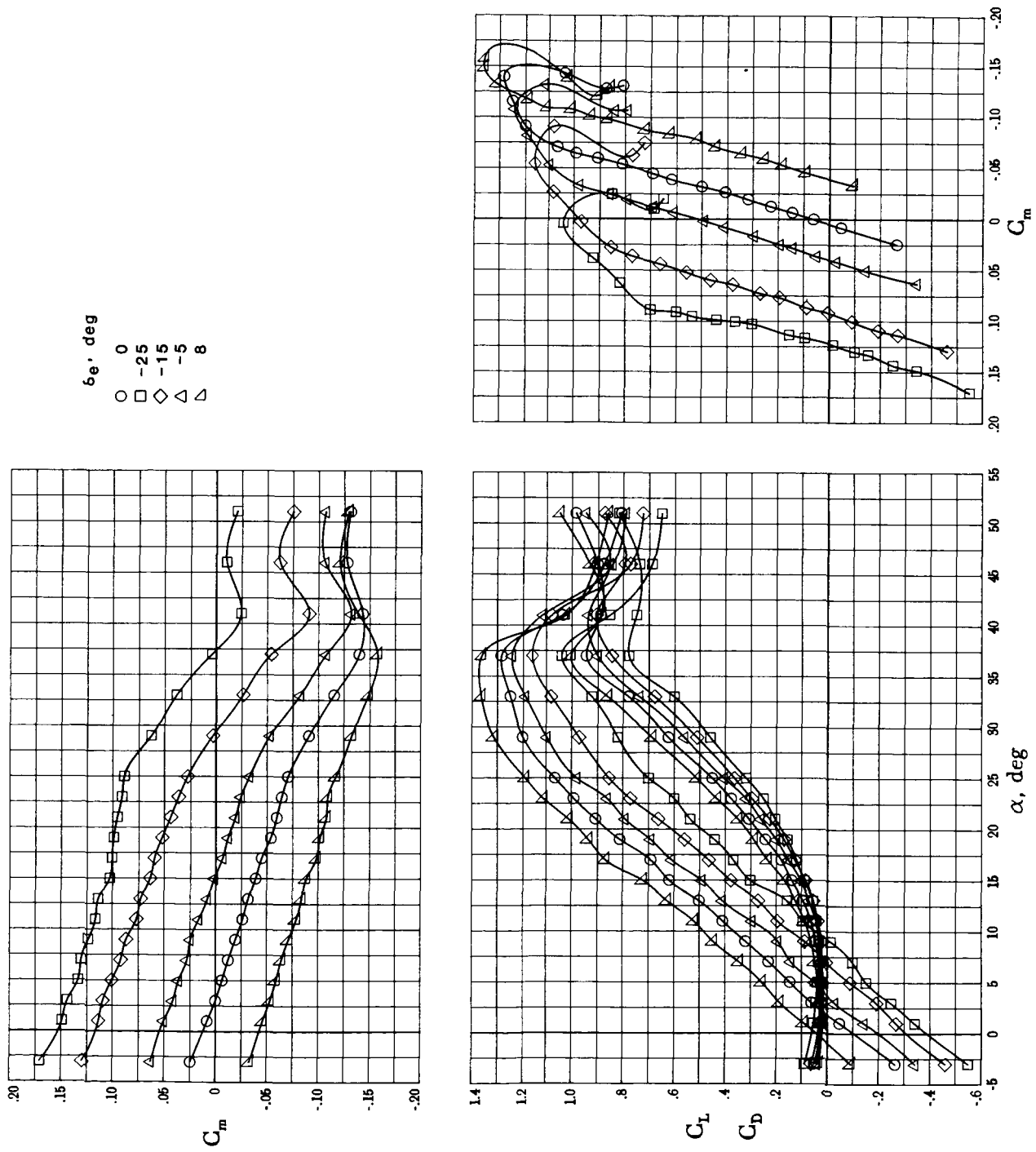

Figure 7. Effect of elevon deflection on longitudinal characteristics. Basic configuration.

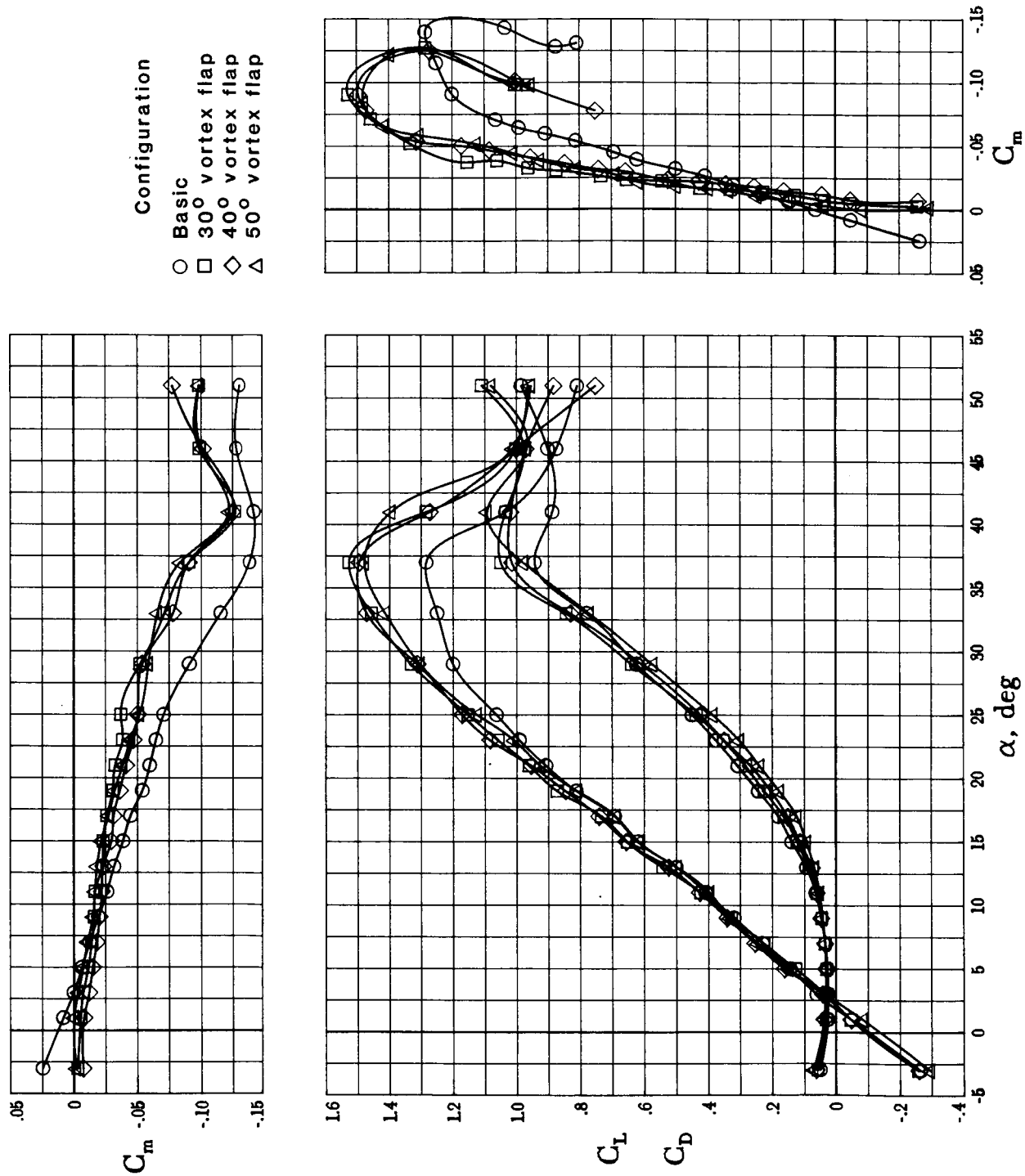

Figure 8. Effect of vortex flap deflection on longitudinal characteristics.  $\delta_e = 0^\circ$ .

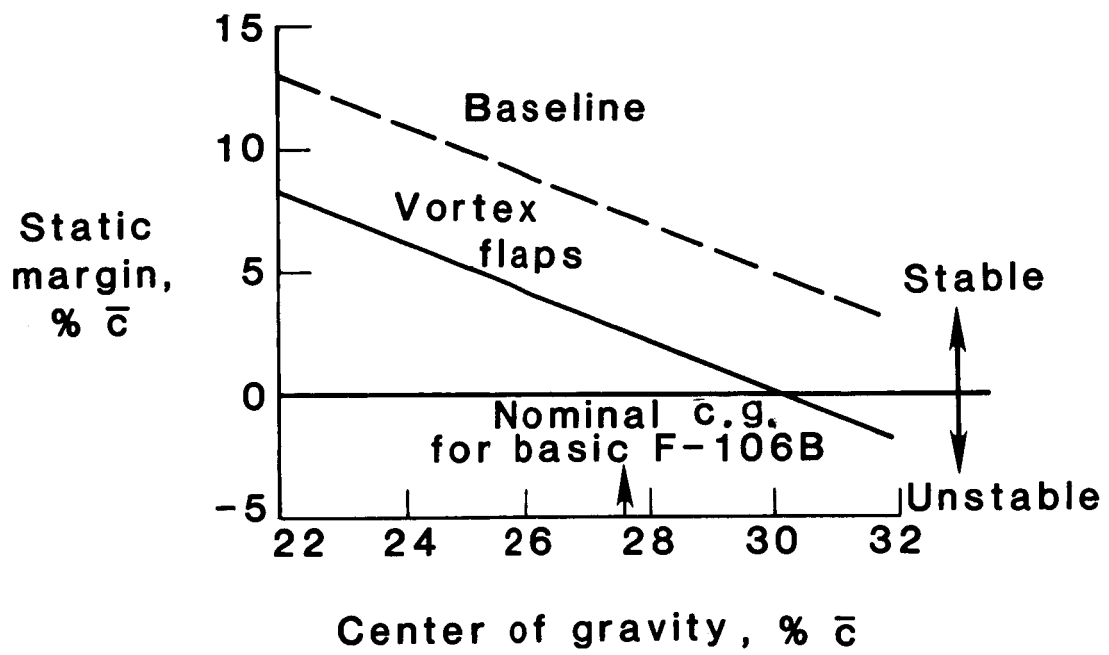

Figure 9. Static margin of basic and 30° vortex flap configurations.

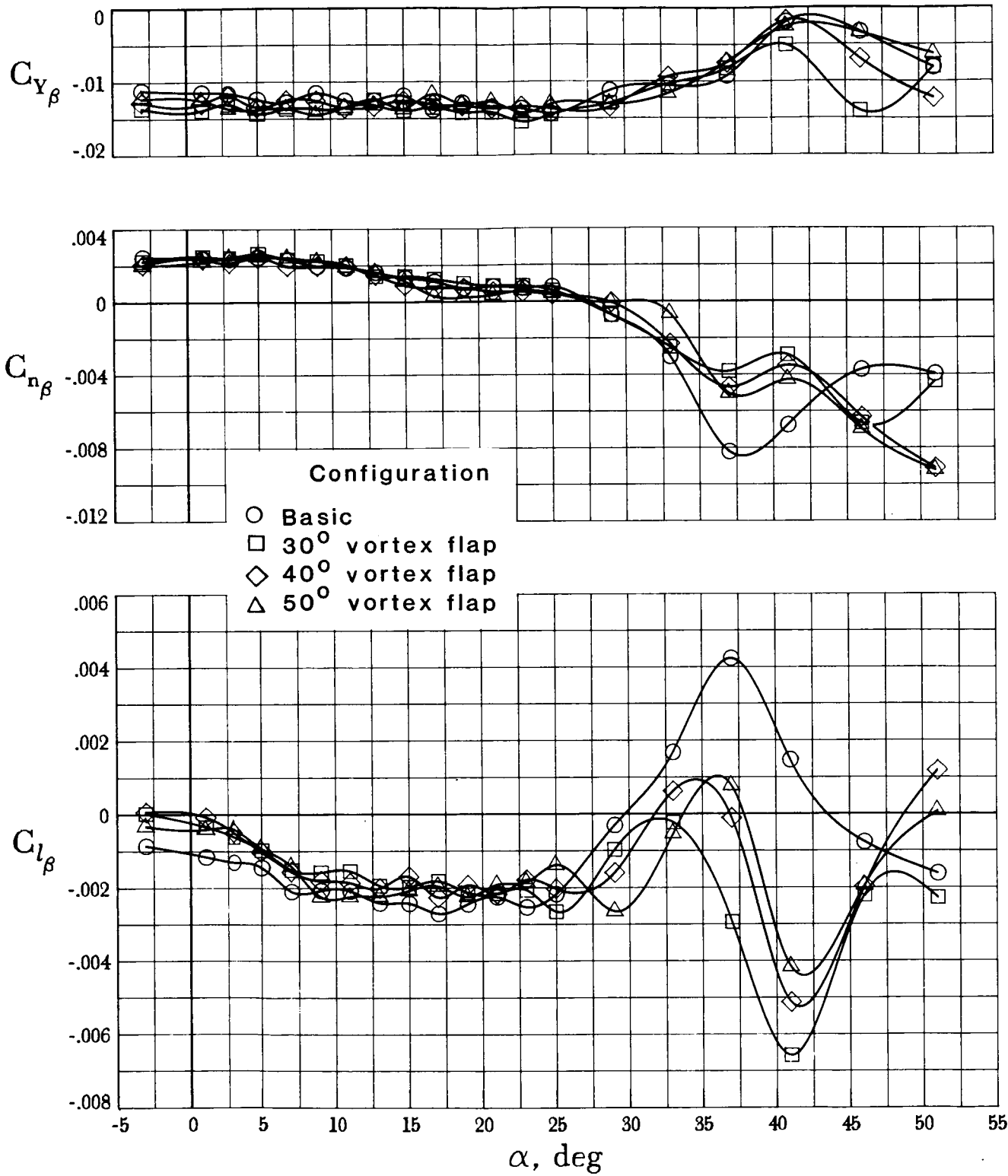

Figure 10. Effect of vortex flap deflection on lateral-directional characteristics.  $\delta_e = 0^\circ$ .



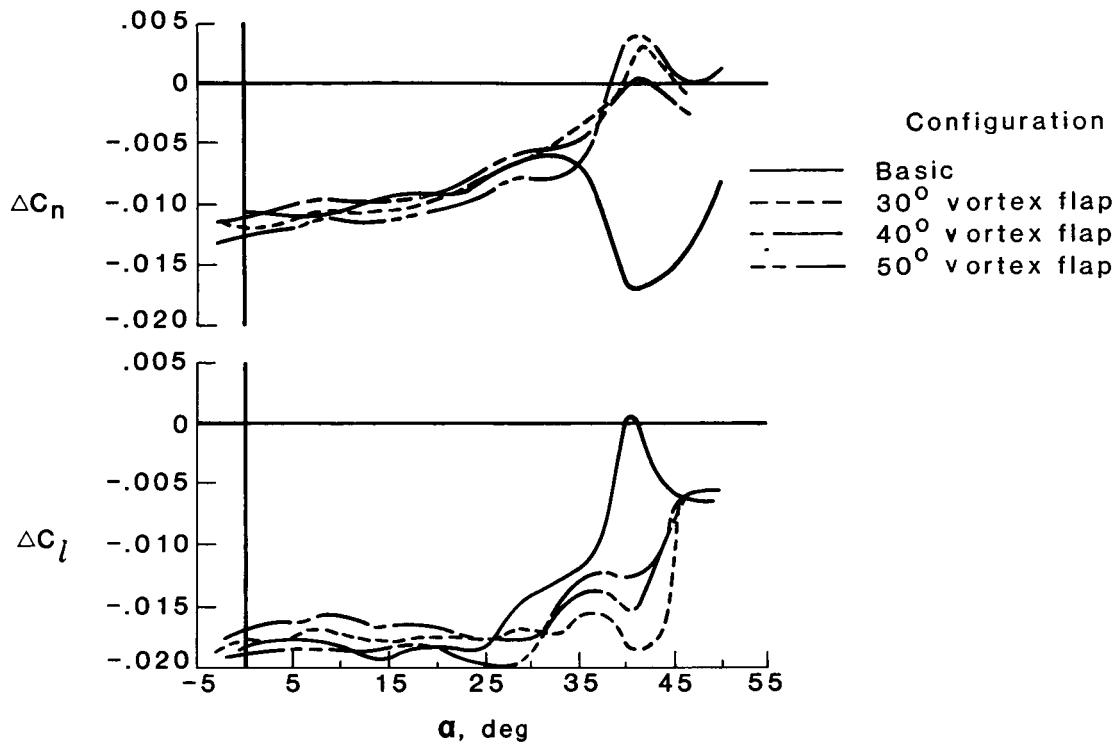

Figure 11. Effect of vortex flap deflection on aileron control power.  $\delta_\alpha = 7^\circ$ ;  $\delta_e = 0^\circ$ .

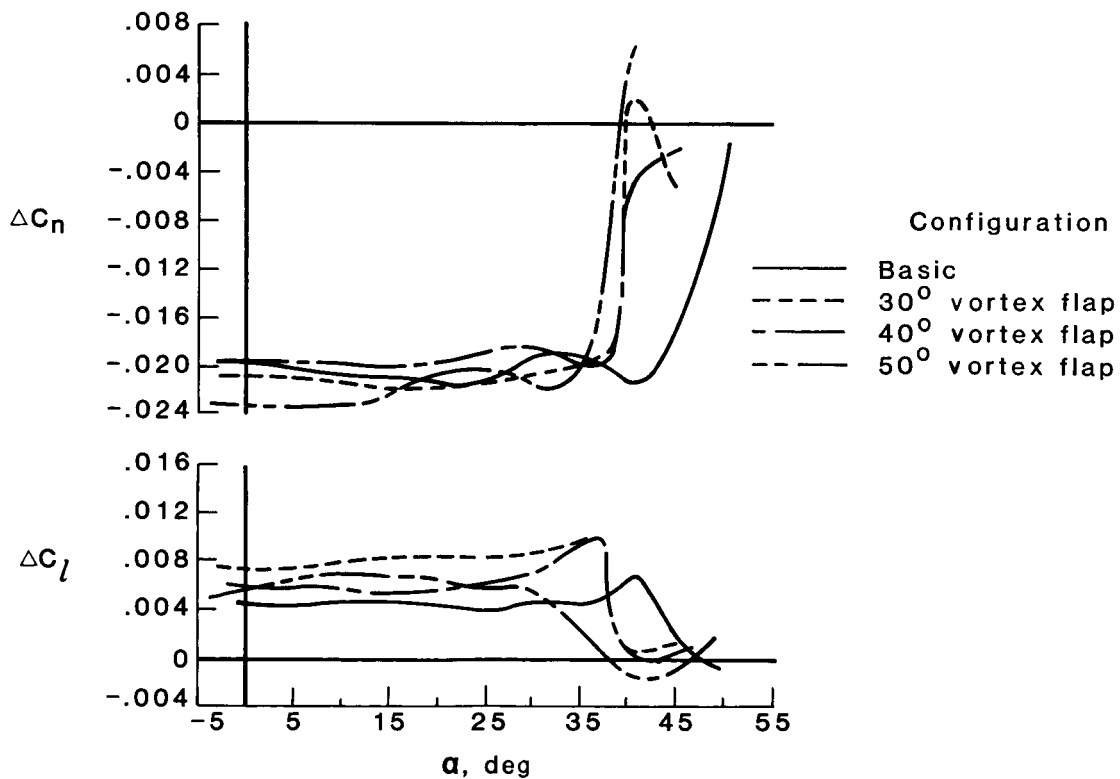

Figure 12. Effect of vortex flap deflection on rudder control power.  $\delta_r = 25^\circ$ .

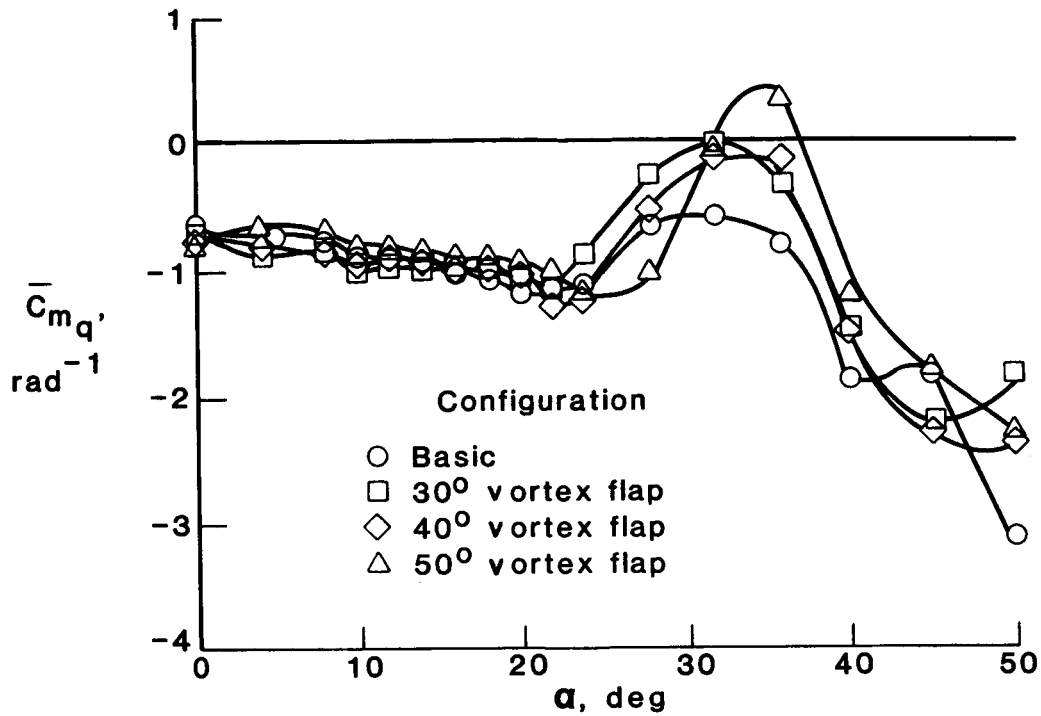

Figure 13. Effect of vortex flap deflection on pitch damping.

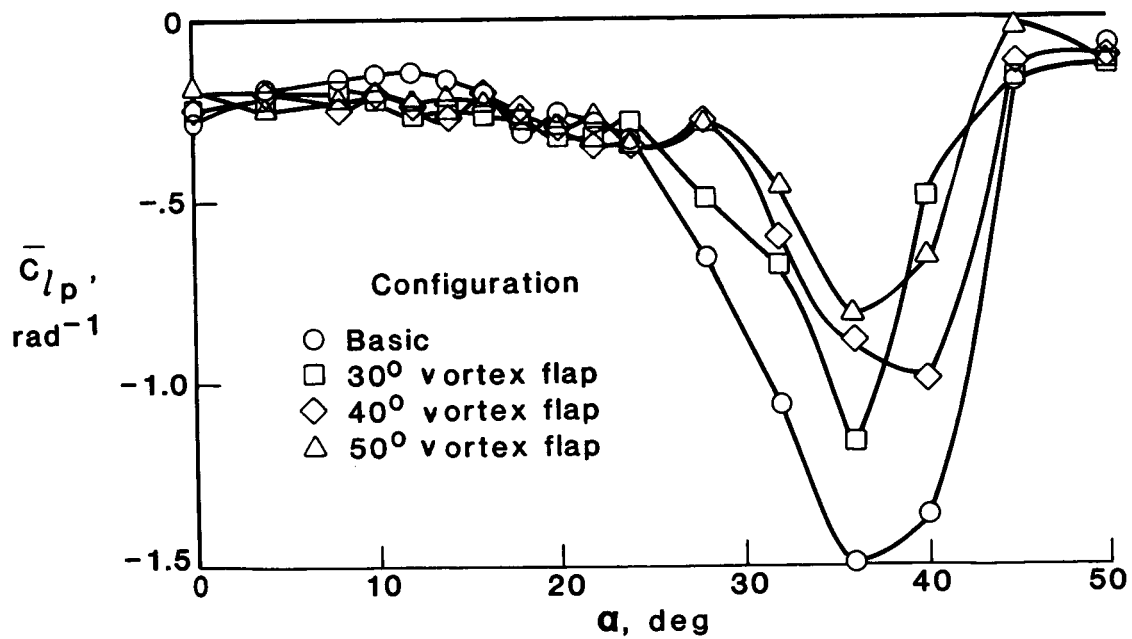

Figure 14. Effect of vortex flap deflection on roll damping.

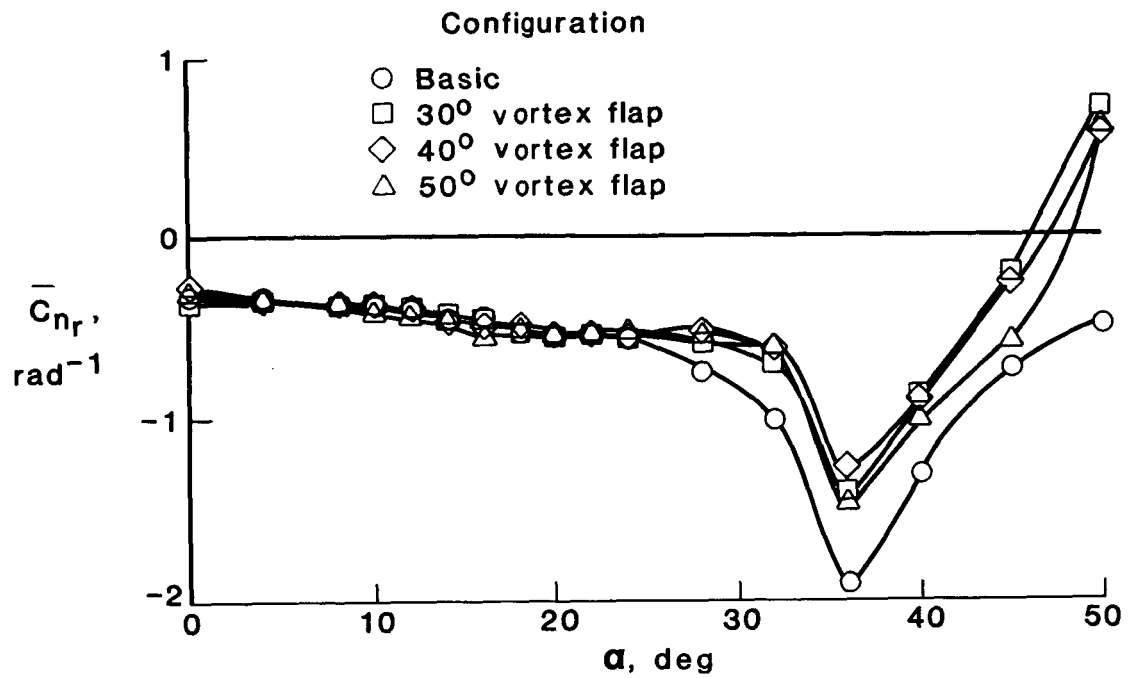

Figure 15. Effect of vortex flap deflection on yaw damping.

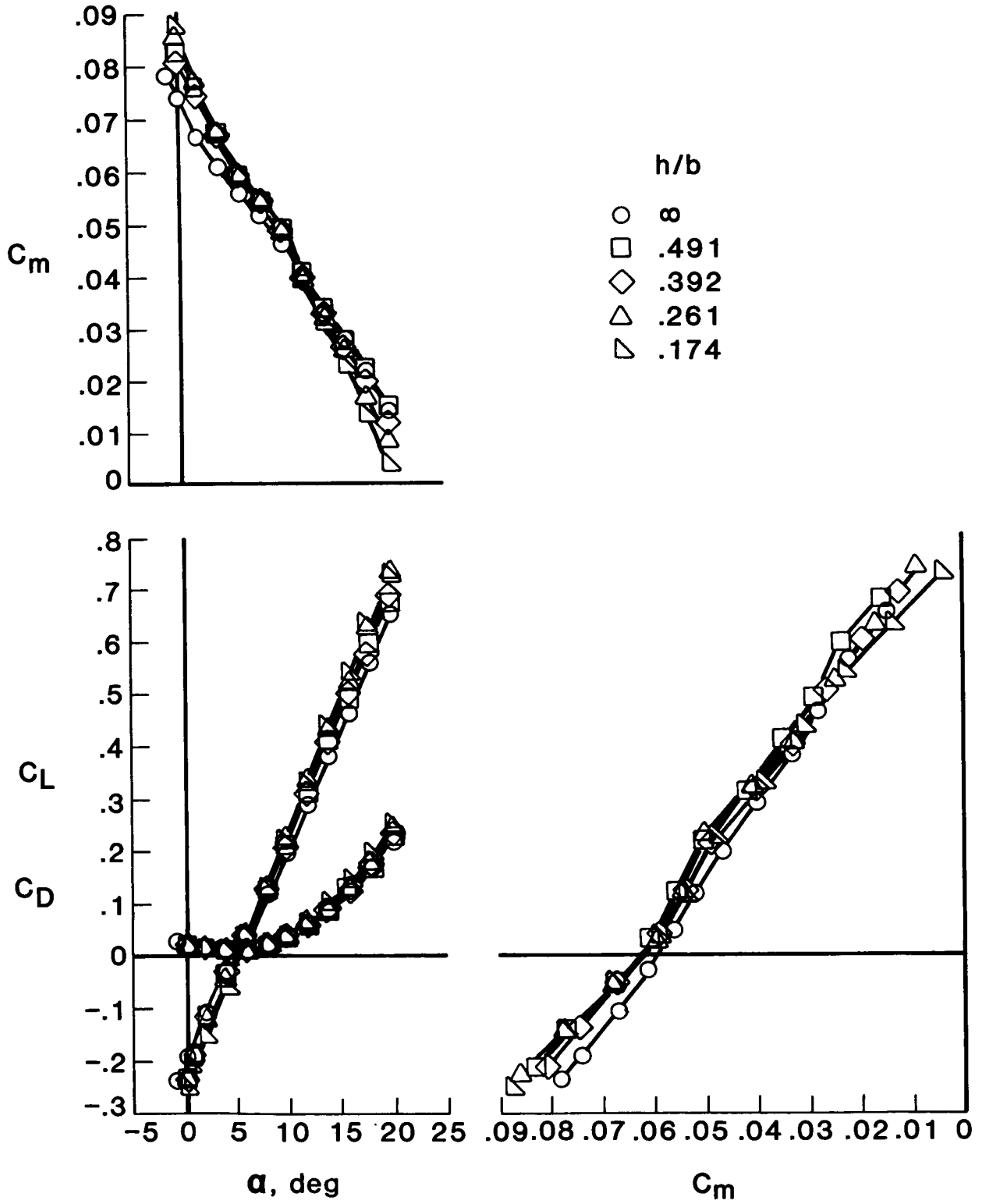

Figure 16. Ground effects for basic configuration.

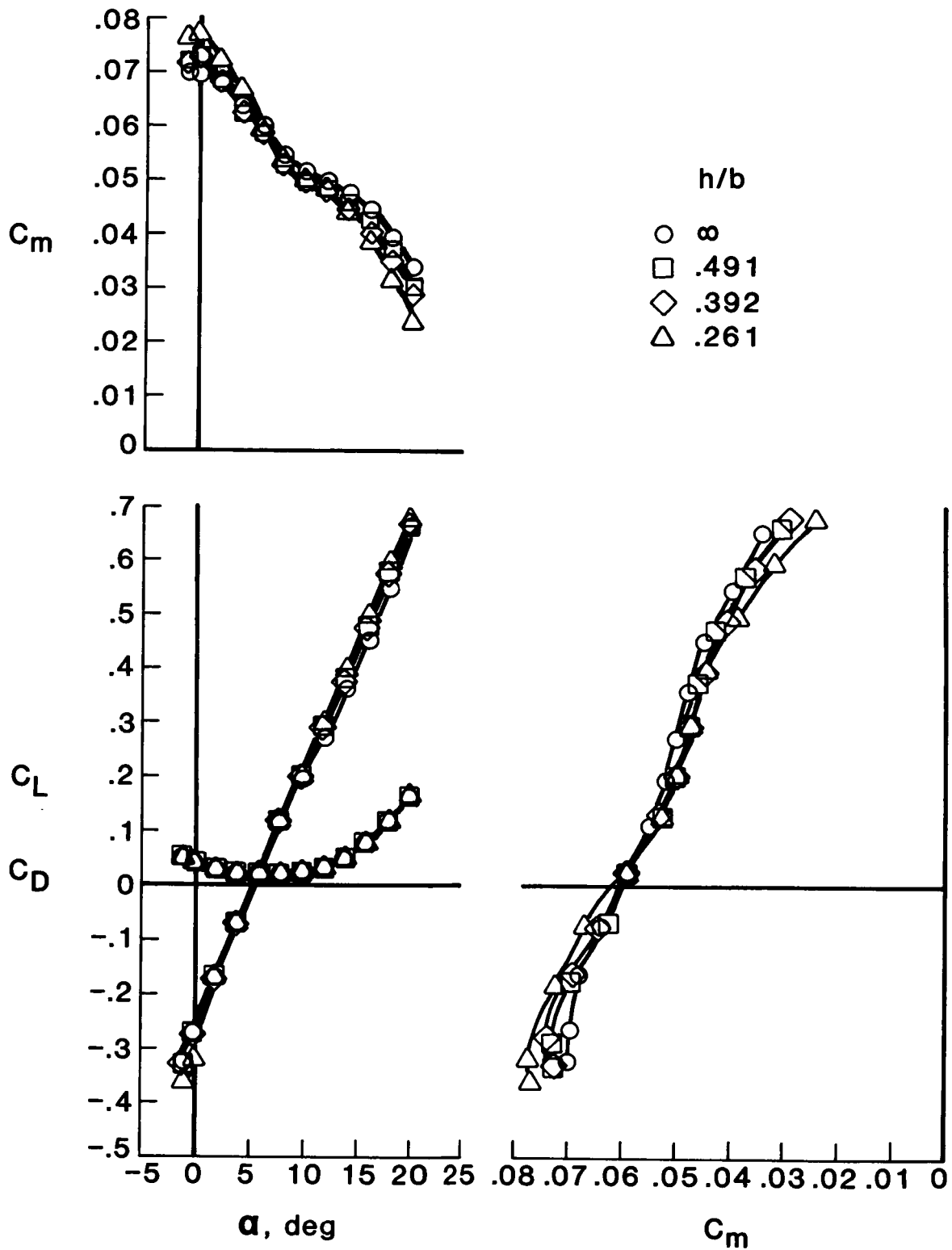

Figure 17. Ground effects for 50° vortex flap configuration.

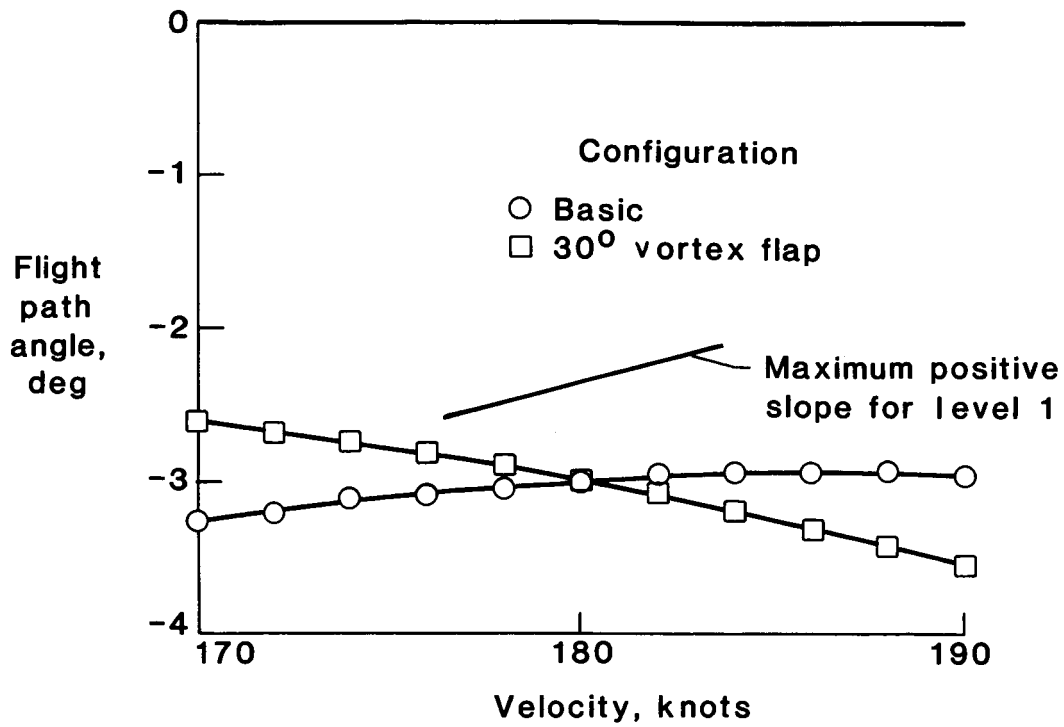

Figure 18. Effect of vortex flap deflection on flight path stability.

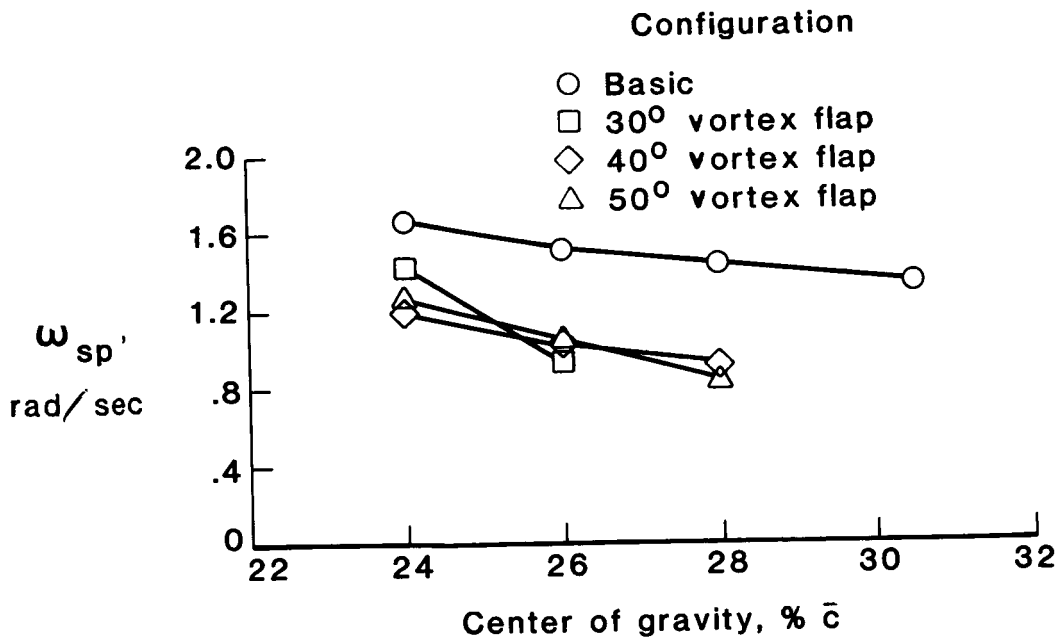

Figure 19. Effect of vortex flap deflection on short-period frequency.

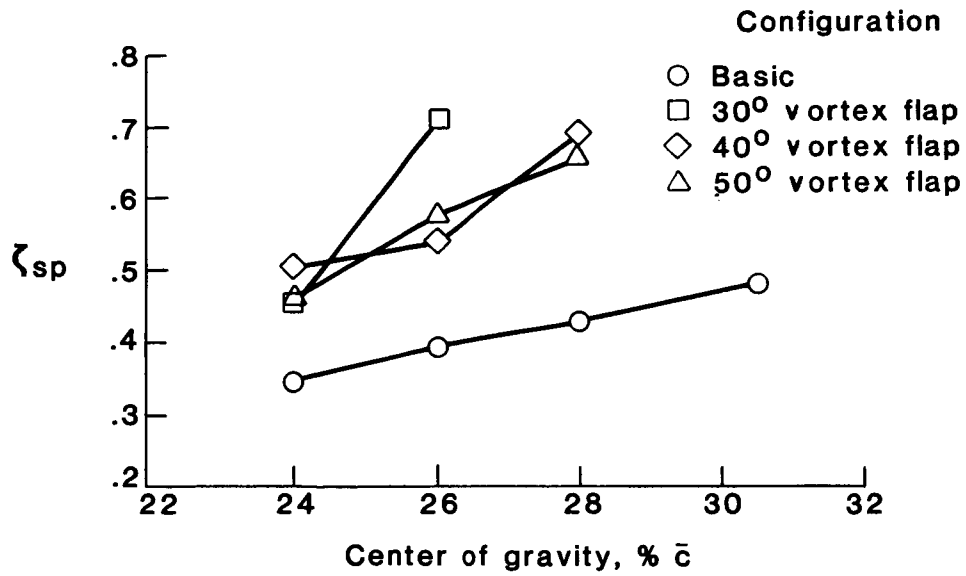

Figure 20. Effect of vortex flap deflection on short-period damping ratio.

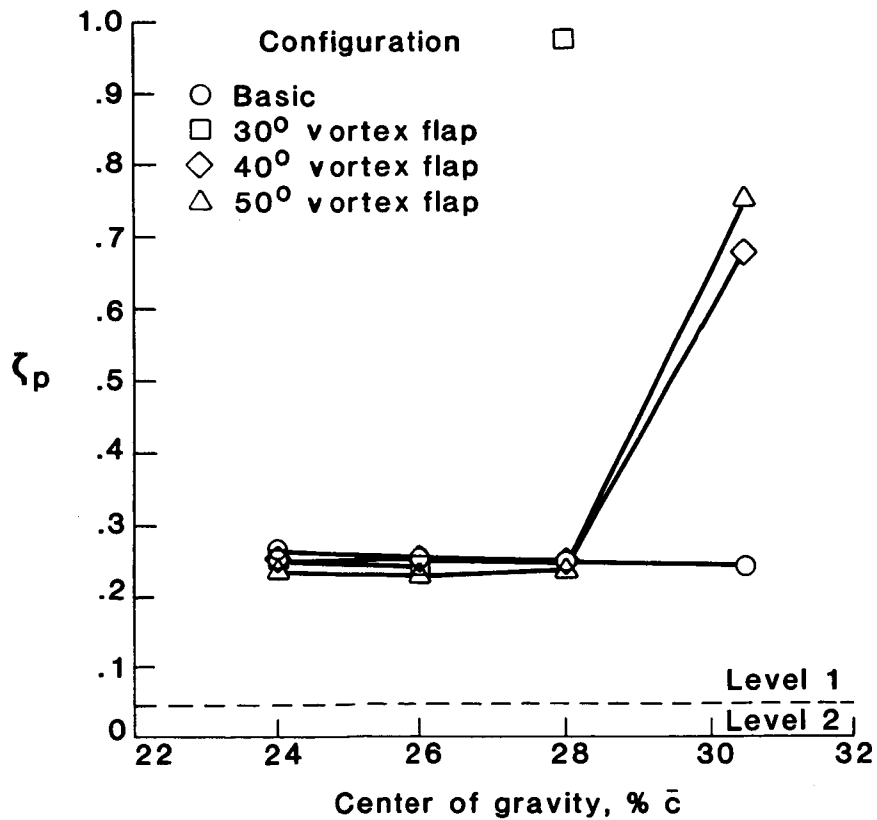

Figure 21. Effect of vortex flap deflection on phugoid damping ratio.

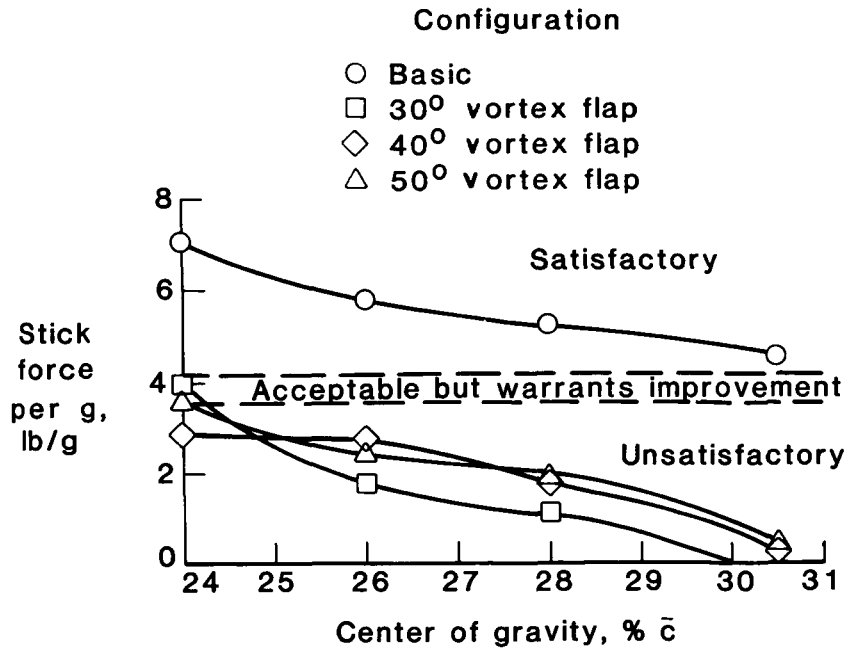

Figure 22. Effect of vortex flap deflection on pitch-control sensitivity.

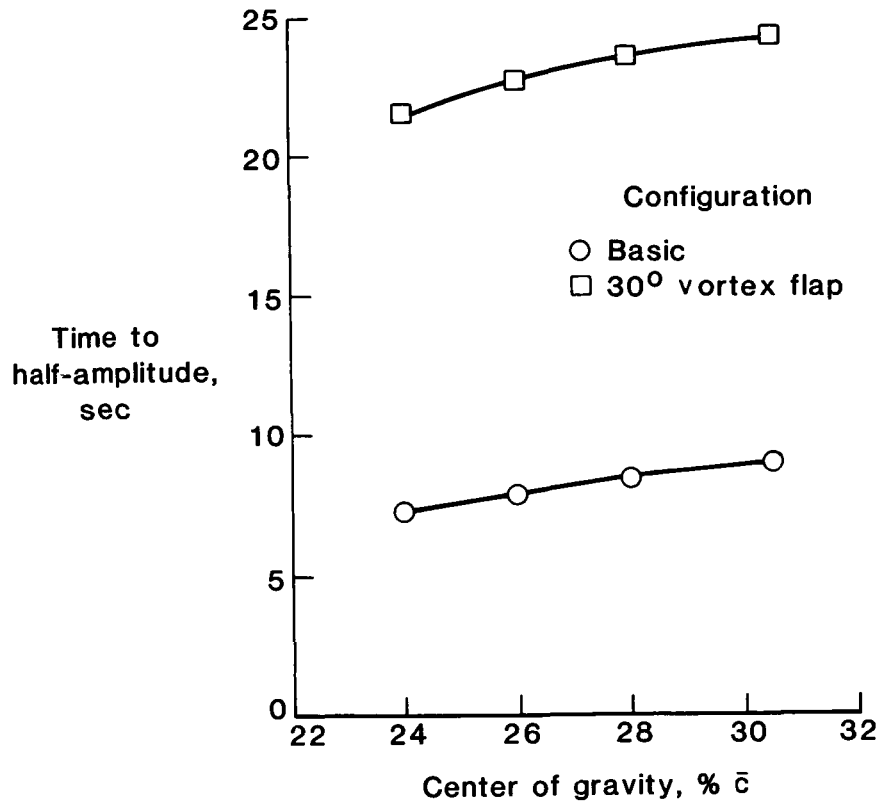

Figure 23. Effect of vortex flap deflection on spiral stability.



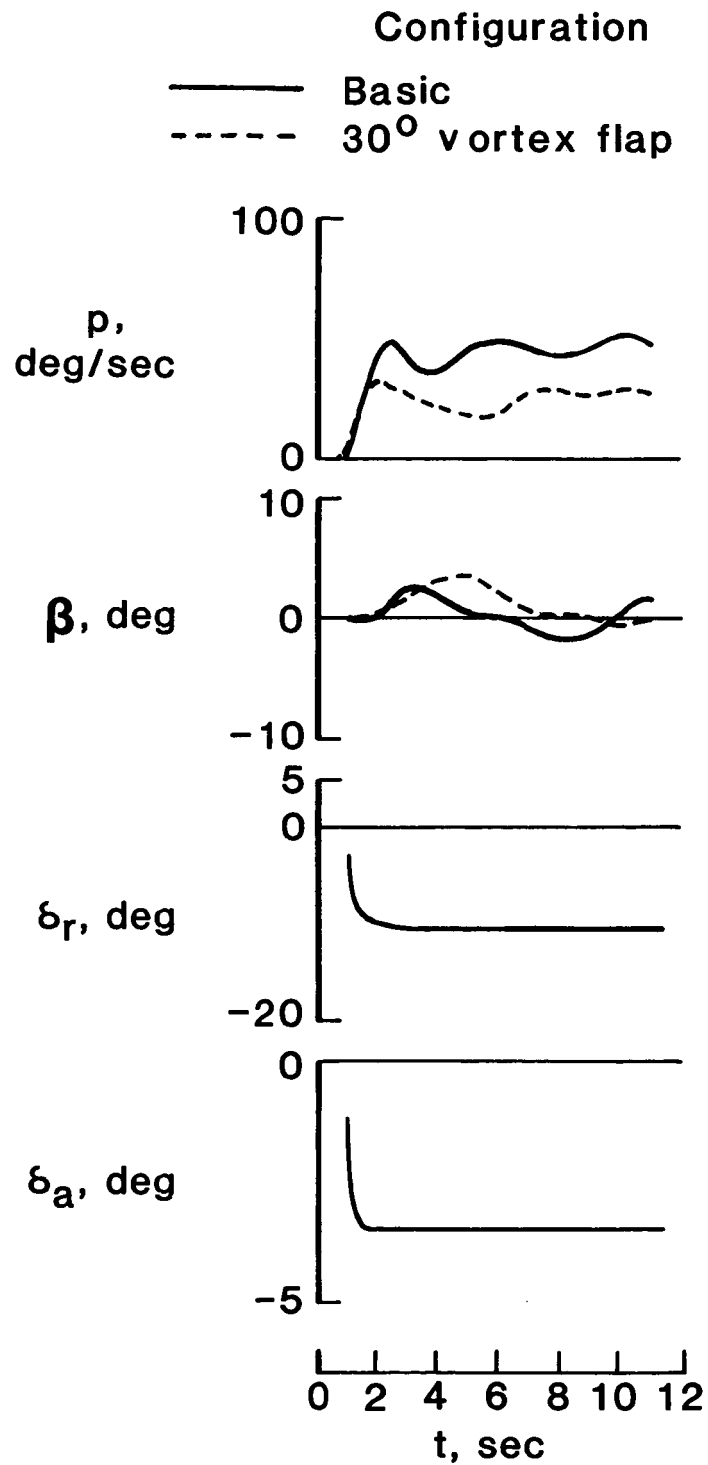

Figure 24. Response to abrupt roll-control input.

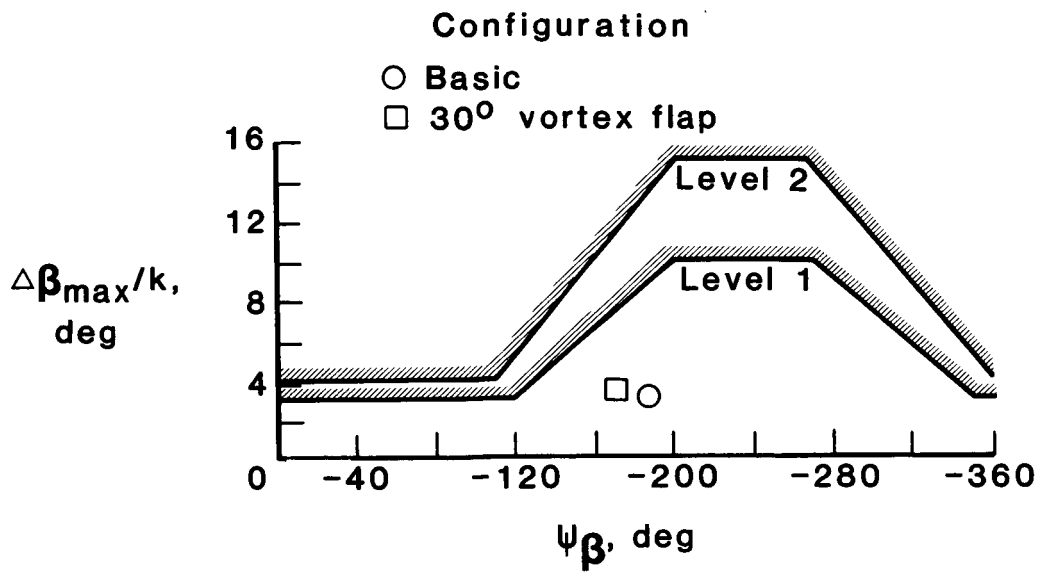

Figure 25. Sideslip excursion parameter.

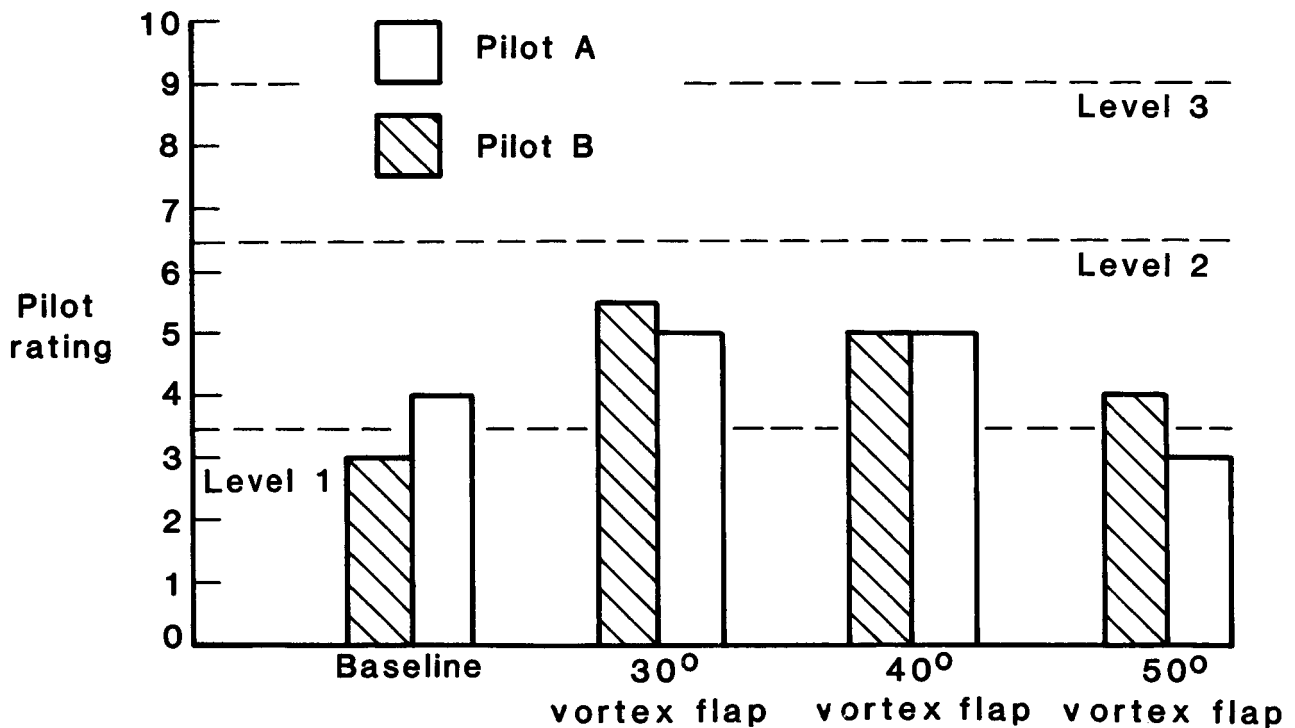
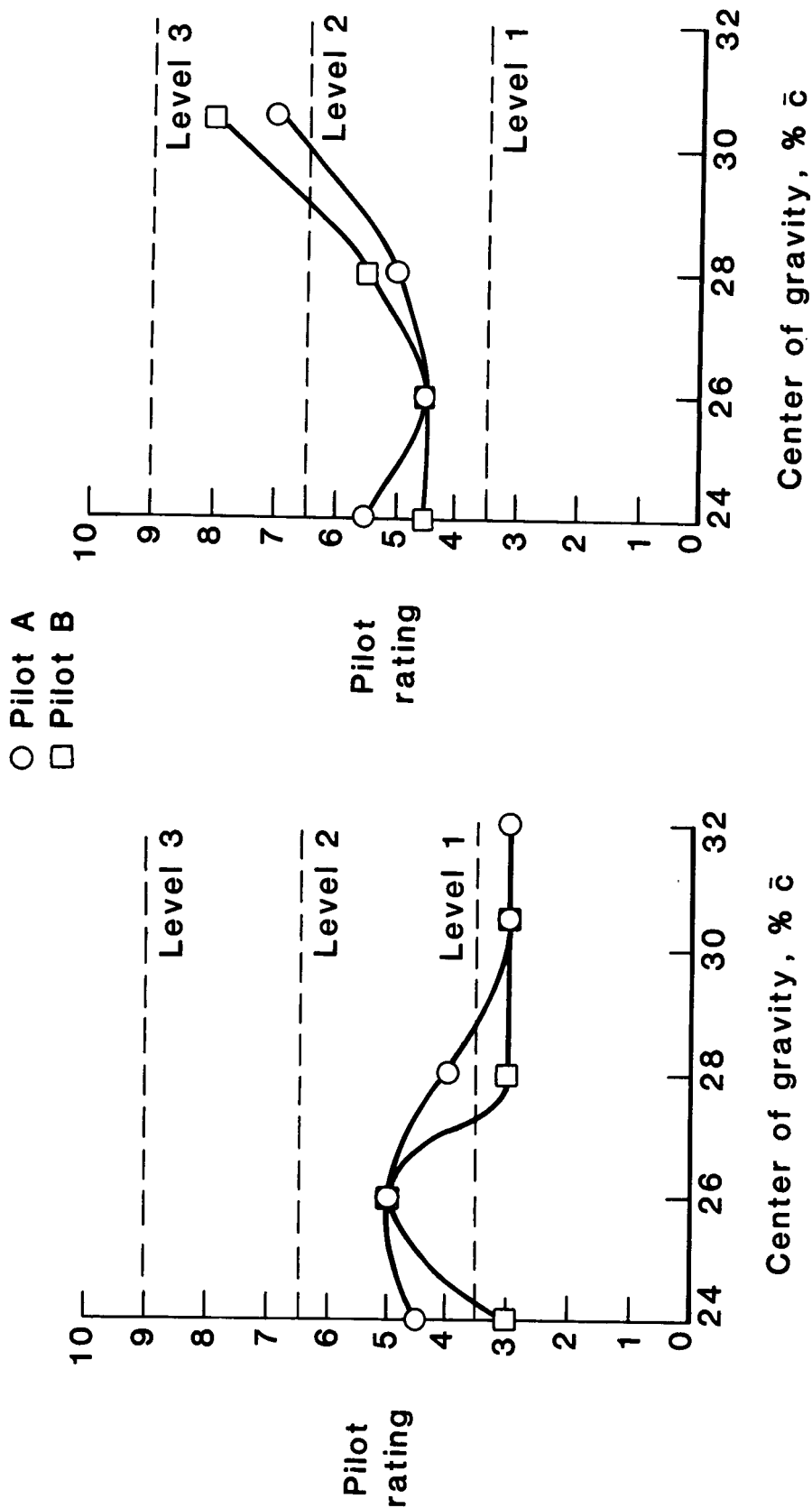

Figure 26. Effect of vortex flap deflection on handling qualities. c.g. = 28 percent  $\bar{c}$ .



(a) Basic configuration.

(b) 30° vortex flap configuration.

Figure 27. Effect of center-of-gravity location on pilot rating.

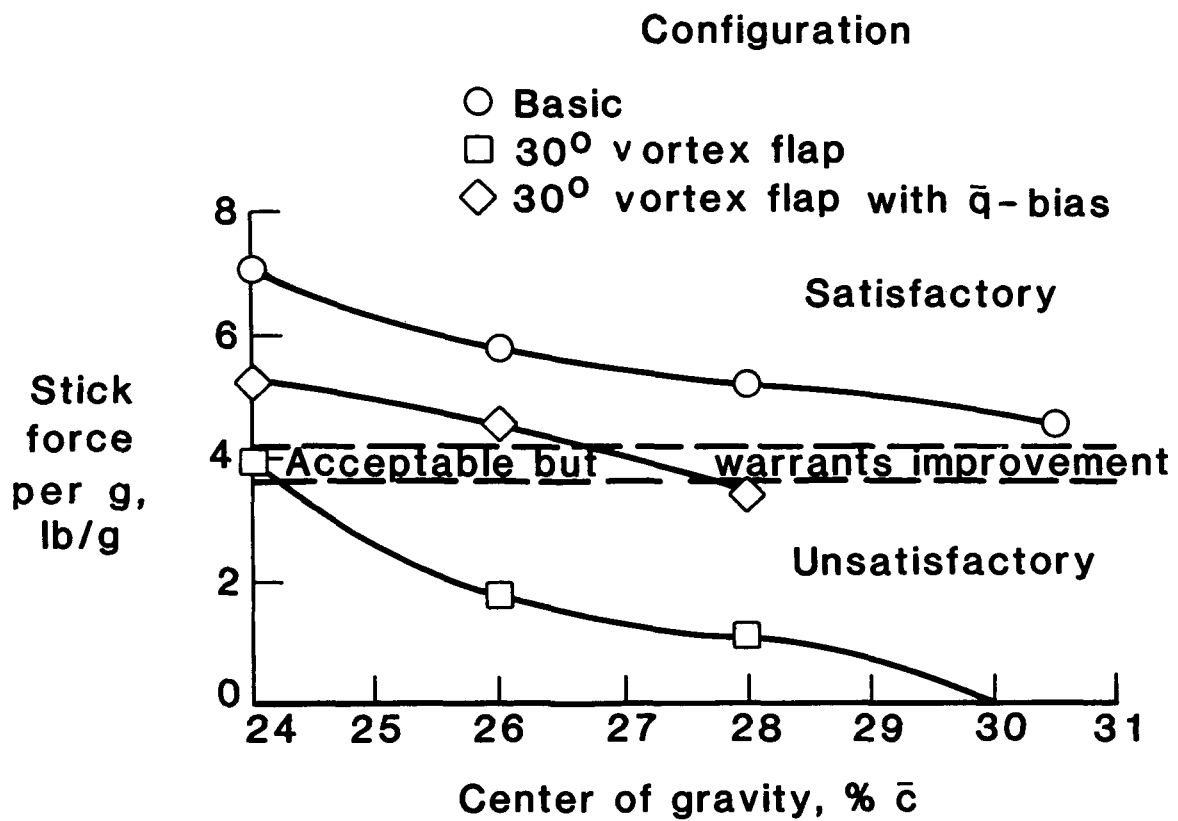
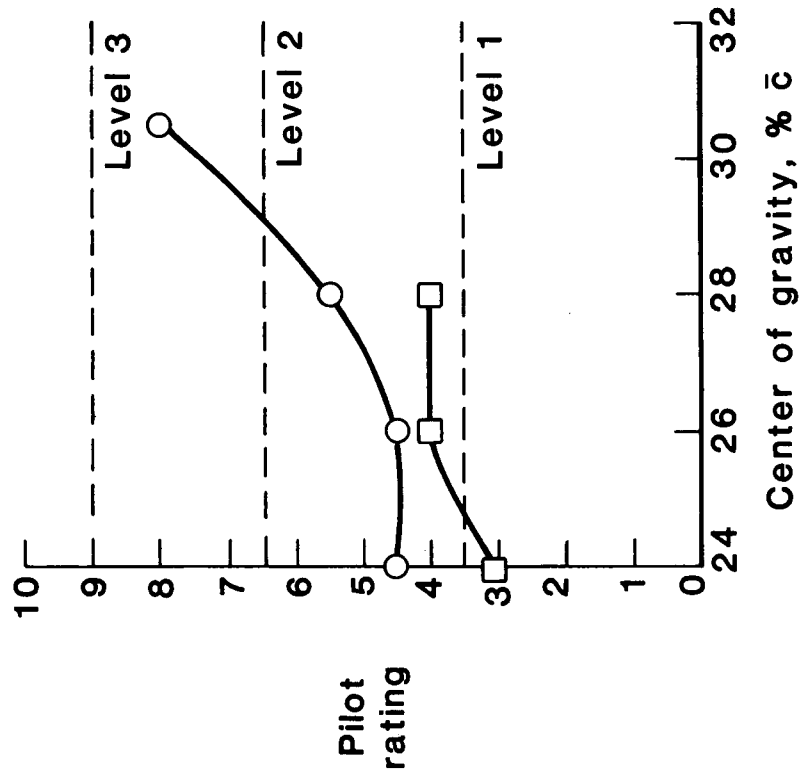

Figure 28. Effect of increased stick-force gradient on pitch-control sensitivity.

Configuration

- 30° vortex flap
- 30° vortex flap with  $\bar{q}$ -bias



(a) Pilot A.

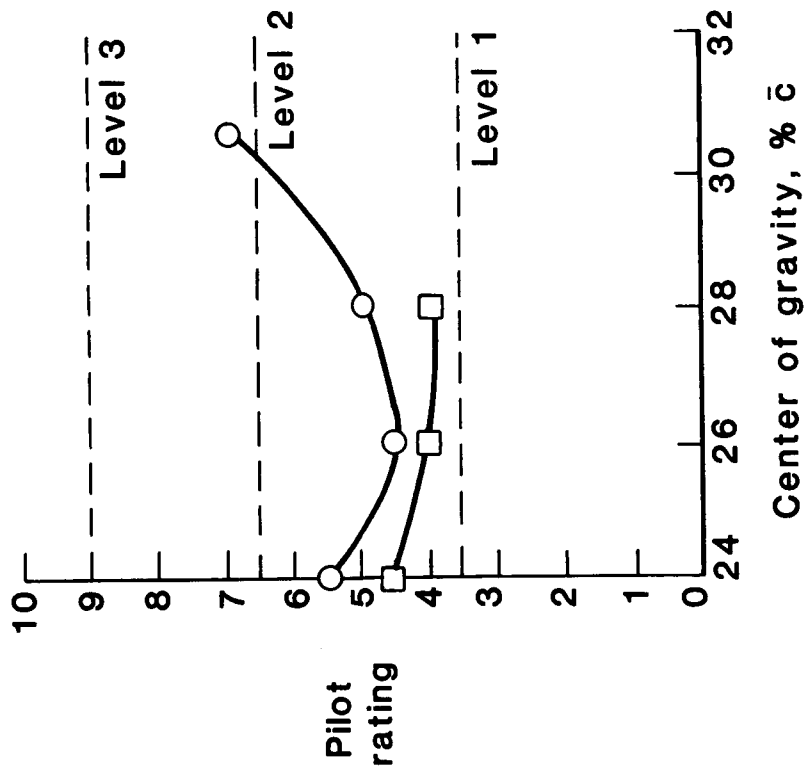

(b) Pilot B.

Figure 29. Effect of  $\bar{q}$ -bias on pilot rating.



# Report Documentation Page

1. Report No. NASA TP-2747	2. Government Accession No.	3. Recipient's Catalog No.	
4. Title and Subtitle Piloted-Simulation Study of Effects of Vortex Flaps on Low-Speed Handling Qualities of a Delta-Wing Airplane		5. Report Date September 1987	
		6. Performing Organization Code	
7. Author(s) Jay M. Brandon, Philip W. Brown, and Alfred J. Wunschel		8. Performing Organization Report No. L-16307	
		10. Work Unit No. 505-61-71-07	
9. Performing Organization Name and Address NASA Langley Research Center Hampton, VA 23665-5225		11. Contract or Grant No.	
		13. Type of Report and Period Covered Technical Paper	
12. Sponsoring Agency Name and Address National Aeronautics and Space Administration Washington, DC 20546-0001		14. Sponsoring Agency Code	
		15. Supplementary Notes Jay M. Brandon and Philip W. Brown: NASA Langley Research Center, Hampton, Virginia. Alfred J. Wunschel: U.S. Air Force Systems Command, assigned to Langley Research Center, Hampton, Virginia.	
16. Abstract A piloted-simulation study was conducted to investigate the effects of vortex flaps on low-speed handling qualities of a delta-wing airplane. The simulation math model was developed from wind-tunnel tests of a 0.15-scale model of the F-106B airplane. Pilot evaluations were conducted using a six-degree-of-freedom motion base simulator. The results of the investigation showed that the reduced static longitudinal stability caused by the vortex flaps significantly degraded handling qualities in the approach-to-landing task. Acceptable handling qualities could be achieved by limiting the aft center-of-gravity location, consequently reducing the operational envelope of the airplane. Further improvements were possible by modifying the flight control force-feel system to reduce pitch-control sensitivity.			
17. Key Words (Suggested by Authors(s)) Vortex flap Handling qualities Piloted simulation F-106B		18. Distribution Statement Unclassified—Unlimited  Subject Category 08	
19. Security Classif.(of this report) Unclassified	20. Security Classif.(of this page) Unclassified	21. No. of Pages 36	22. Price A03