

DOE/NASA/33408-2
NASA TM-100111
AIAA-87-9069

92852

P-18

Comparison of Stirling Engines for Use With a 25-kW Dish-Electric Conversion System

Richard K. Shaltens
National Aeronautics and Space Administration
Lewis Research Center

(NASA-TM-100111) COMPARISON OF STIRLING
ENGINES FOR USE WITH A 25-kW DISK-ELECTRIC
CONVERSION SYSTEM (NASA) 18 p Avail: NTIS
EC A02/MF A01 CSCL 13F

N87-27564

Unclas
G3/85 0092852

Work performed for

U.S. DEPARTMENT OF ENERGY
Conservation and Renewable Energy
Office of Solar Heat Technologies

Prepared for the
22nd Intersociety Energy Conversion Engineering Conference
cosponsored by AIAA, ANS, ASME, SAE, IEEE, ACS, and AIChE
Philadelphia, Pennsylvania, August 10-14, 1987

DISCLAIMER

This report was prepared as an account of work sponsored by an agency of the United States Government. Neither the United States Government nor any agency thereof, nor any of their employees, makes any warranty, express or implied, or assumes any legal liability or responsibility for the accuracy, completeness, or usefulness of any information, apparatus, product, or process disclosed, or represents that its use would not infringe privately owned rights. Reference herein to any specific commercial product, process, or service by trade name, trademark, manufacturer, or otherwise, does not necessarily constitute or imply its endorsement, recommendation, or favoring by the United States Government or any agency thereof. The views and opinions of authors expressed herein do not necessarily state or reflect those of the United States Government or any agency thereof.

Printed in the United States of America

Available from

National Technical Information Service
U.S. Department of Commerce
5285 Port Royal Road
Springfield, VA 22161

NTIS price codes¹

Printed copy: A02
Microfiche copy: A01

¹Codes are used for pricing all publications. The code is determined by the number of pages in the publication. Information pertaining to the pricing codes can be found in the current issues of the following publications, which are generally available in most libraries: *Energy Research Abstracts (ERA)*; *Government Reports Announcements and Index (GRA and I)*; *Scientific and Technical Abstract Reports (STAR)*; and publication, NTIS-PR-360 available from NTIS at the above address.

DOE/NASA/33408-2
NASA TM-100111
AIAA-87-9069

Comparison Stirling Engines for Use With a 25-kW Dish-Electric Conversion System

Richard K. Shaltens
National Aeronautics and Space Administration
Lewis Research Center
Cleveland, Ohio 44135

Work performed for
U.S. DEPARTMENT OF ENERGY
Conservation and Renewable Energy
Office of Solar Heat Technologies
Washington, D.C. 20545
Under Interagency Agreement DE-AT04-85AL33408

Prepared for the
22nd Intersociety Energy Conversion Engineering Conference
cosponsored by AIAA, ANS, ASME SAE, IEEE, ACS, and AIChE
Philadelphia, Pennsylvania, August 10-14, 1987

COMPARISON OF STIRLING ENGINES
FOR USE WITH A 25-KW DISH-ELECTRIC CONVERSION SYSTEM

Richard K. Shaltens
National Aeronautics and Space Administration
Lewis Research Center
Cleveland, Ohio 44135

SUMMARY

The Department of Energy's (DOE) Solar Thermal Technology Program, Sandia National Laboratories (SNLA), is evaluating heat engines for terrestrial solar distributed heat receivers. The Stirling engine has been identified by SNLA as one of the most promising engines for terrestrial applications. The potential to meet DOE's goals for performance and cost can be met by the free-piston Stirling engine.

NASA Lewis Research Center is conducting Stirling activities directed toward a dynamic power source for the space application. Space power systems requirements include high reliability, very long life, low vibration, and high efficiency. The free-piston Stirling engine has the potential for future high-power space conversion systems, either nuclear or solar powered. Although both applications, terrestrial and space power, appear to be quite different, their requirements complement each other.

NASA Lewis is providing technical management for an Advanced Stirling Conversion System (ASCS) through a cooperative Interagency Agreement with DOE. Parallel contracts have been awarded to Mechanical Technology, Inc. (MTI) of Latham, New York, and Stirling Technology Company (STC) of Richland, Washington, for the conceptual designs of an ASCS. Each design will feature a free-piston Stirling engine, a liquid-metal heat pipe receiver, and a means to provide about 25 kW of electric power to a utility grid while meeting DOE's long-term performance and cost goals.

The MTI design incorporates a linear alternator to directly convert the solar energy to electricity while STC generates electrical power indirectly by using a hydraulic output to a ground-based hydraulic pump/motor coupled to a rotating alternator. Both designs for the ASCS's will use technology which can reasonably be expected to be available in the 1980's. Both the MTI and STC concepts will be evaluated by the same, but independent, contractor to provide a manufacturing and cost analysis including life cycle cost. The ASCS designs using a free-piston Stirling engine, a heat transport system, a receiver, and the methods of providing electricity to the utility grid will be discussed.

INTRODUCTION

Under DOE's Solar Thermal Technology Program, Sandia National Laboratories (SNLA) is evaluating heat engines for terrestrial solar distributed heat receivers. Of the available heat engine technologies, SNLA has identified the Stirling to be one of the most promising candidates to meet the DOE goals for both performance and cost.

NASA Lewis has pursued the Stirling cycle as a candidate dynamic power converter for future high-power space conversion systems since the 1960's. Unique Stirling expertise and a technology base gradually developed at Lewis during the 1970's. The need to develop automotive powerplant alternatives in the late 1970's initiated the U.S. Department of Energy's Automotive Stirling Engine (ASE) Program which was planned and implemented by Lewis. A consequence of the ASE Program was an accelerated effort which has provided significant expansion in the research and technology of Stirling engines. This has resulted in a synergetic technology base at Lewis and its contractors.

The Stirling Engine Project Office at Lewis is responsible for a variety of projects including both kinematic and free-piston Stirling engines. Testing and evaluating a wide variety of these engines have included the GPU-3 (3 kW), P-40 (40 kW), Mod I ASE (60 kW), and RE-1000 (1 kW) with a dashpot load. Engine performance has been mapped to provide data for computer code validation. Lewis is currently testing the RE-1000 with a hydraulic output and has started testing a 12.5-kW space power research engine (SPRE) as a test bed for further evaluation of larger free-piston Stirling engines for space.

Current projections for space power requirements are shown in figure 1. Space power system requirements include high efficiency, high reliability, very long life, and low vibration. In addition, system weight and operating temperatures are important parameters. Unlike the kinematic Stirling engine, which was invented by the Reverend Robert Stirling in 1816, the free-piston Stirling engine (FPSE) concept is a very recent invention. The FPSE has the potential to be the future dynamic power source for space power applications, either nuclear or solar powered. An overview of the free-piston activities at Lewis is contained in reference 1.

The free-piston Stirling engine was invented in 1962 by William Beale at Ohio University. Early work by Beale resulted in small-scale fractional-horsepower free-piston engine. The major advantage of the FPSE over the kinematic Stirling engine is that it has only two moving parts, noncontacting gas bearings, and can be hermetically sealed, thereby increasing the potential for high reliability and very long life. A simplified drawing of a FPSE with a linear alternator is shown in figure 2. A detailed discussion of the Beale FPSE is contained in reference 2. Only a few organizations in the United States are currently developing the FPSE. These include Sunpower Inc. of Athens, Ohio, Mechanical Technology, Inc. (MTI) of Latham, New York, Stirling Technology Company (STC) (formerly University of Washington) of Richland, Washington, DOE Oak Ridge National Laboratory (ORNL), and NASA Lewis. The FPSE's designed and built have ranged from fractional hp to 33 hp (25 kW). Scaling studies are currently being conducted for Lewis by MTI to determine whether it is feasible to design a single-cylinder FPSE in the 100- to 150-kW range. The design and development of the space power demonstration engine (SPDE) built by MTI for NASA has demonstrated power in excess of 25 kW (17 kW_e), nearly seven times the power produced by earlier FPSE's. The SPDE is shown in figure 3.

ADVANCED STIRLING CONVERSION SYSTEM

DOE signed a cooperative Interagency Agreement (IAA) in 1985 with Lewis to provide technical management for the Advanced Stirling Conversion System (ASCS). Under this IAA, the ASCS Project is providing DOE/SNLA with conceptual

designs of free-piston Stirling engine systems which have the potential of meeting DOE's long-term performance and cost goals. The DOE cost goals are shown in table I (ref. 3). Objectives of the ASCS Project are as follows:

- Define the ASCS configuration
- Predict ASCS performance over a range of solar inputs
- Estimate system and major component weight
- Define engine and electrical power conditioning and control requirements
- Define key technology needs not ready by the late 1980's in meeting goals
- Provide a manufacturability and cost evaluation for the engine power conversion system

Competitive contracts for the conceptual designs and cost and manufacturing studies for the ASCS were awarded to both MTI and STC in late 1986.

The proposals from MTI and STC were judged to be unique yet complementary to each other. Each conceptual design features the Stirling engine, a heat transport system as part of the solar receiver, a means to generate electric power, the necessary auxiliaries, and a control system. The ASCS is being designed to mount to and receive concentrated solar energy from an 11-m test bed concentrator (TBC) located at the SNLA test facility. The TBC characteristics are given in table II. Also, the conceptual designs have predicted ASCS performance over a range of solar inputs, estimated system and major component weights, and defined engine and electrical power conditioning and control requirements. Each conceptual design includes existing technology, available by the late 1980's. The ASCS design requirements are shown in table III. At the completion of the conceptual design studies by MTI and STC, an independent manufacturing and cost analysis will be completed by Pioneer Engineering and Manufacturing Company of Warren, Michigan. The goal of the ASCS is to generate a conceptual design capable of generating about 25 kW of electric power to an electric utility grid at an engine/alternator target cost of \$300/kW at the manufacturing rate of 10,000 units/year. The design life of the engine/alternator is 60,000 hr, which includes an engine overhaul at 40,000 hr. One concept will be selected for a follow-on procurement to complete a final design, build hardware, assemble, and test the ASCS at the SNLA test facilities in Albuquerque, New Mexico, by 1990. An artist's conceptualization of the ASCS showing the solar receiver, heat transport system, Stirling engine/linear alternator, and heat rejection system is shown in figure 4.

As stated earlier, the MTI and STC concepts are unique with complementary characteristics. The major difference is the method of generating the electrical power. MTI is using a 25-kW_e single-piston FPSE as their baseline. It incorporates a linear alternator to directly convert the energy to useful electricity on the utility grid. STC has chosen a 25-kW_e FPSE which generates electrical power indirectly by use of a hydraulic output to a ground-based fluid pump coupled to a rotating induction generator. Both the MTI and STC concepts will produce 25 kW_e at a heater head (metal) temperature of 800 °C

with helium as the working fluid. A temperature ratio T_H/T_C of 3 for the ASCS results in a system efficiency (solar input to electrical output) of greater than 33 percent. Estimates of over 60,000 kW-hr/year were provided for both the STC and MTI proposed concepts. A comparison of the MTI and STC proposals is provided in table IV. The MTI and STC proposed concepts are discussed in reference 4.

MTI CONCEPTUAL DESIGN

MTI, the prime contractor, is responsible for both project management and the free-piston Stirling engine/linear alternator design and system integration. MTI has teamed with Thermacore, Inc., for the heat transport system design and with Sanders Associates for the solar receiver design. Pioneer Engineering and Manufacturing Company will provide a manufacturing and cost analysis of the MTI conceptual design. MTI proposed using two concepts - (1) the NASA SPDE, a 25-kW_e, two-opposed-piston Stirling engine system and (2) a larger, 25-kW, single-piston Stirling engine - for their ASCS concepts. The proposed designs use a linear alternator for producing electrical power to the grid. Both proposed concepts are shown in figure 5. MTI's approach to solarizing free-piston Stirling engines is discussed in reference 5.

During the initial conceptual design phase the MTI team considered a number of design options to meet DOE's long-term performance and cost goals. Areas evaluated were

- Single versus multiple heat pipe
- Clearance seals versus piston rings
- Annular versus canister heat exchangers
- Material and operating temperature for hot components
- Regenerator materials (foil versus sintered felt metal)
- Magnet materials (permanent versus saturated plunger)
- Piston and cylinder materials (ceramic versus steel)

The MTI "preliminary" conceptual design review was held in March 1987 at the Lewis Research Center in Cleveland, Ohio. The MTI design presented uses a single-piston Stirling engine/linear alternator concept for its baseline design. The receiver concentrates the solar energy received from the collector and transfers it by conduction through a liquid-metal heat pipe to the Stirling engine heater head which operates at 800 °C. A single dish-shaped heat pipe concept (shown in fig. 6) using radial and circumferential arteries was selected. Sodium is the liquid metal chosen for use with the heat pipe. A conventional tubular heater head with an annular regenerator and cooler are used in this design. Hydrodynamic gas bearings have been proposed to spin the displacer and power piston which use close clearance seals. As this concept does not require piston rings and uses hydrodynamic gas bearings, it provides the potential of high reliability with very long life because there are no contacting parts. The thermal energy is converted directly by the Stirling

engine to electrical power via a linear alternator using permanent magnets. An all-welded pressure vessel has been designed to provide hermetic sealing. A vibration absorber on the mounting ring is used to meet the dynamic balancing specifications. The cooler subsystem is mounted on the ground and is similar to a water-glycol automotive cooling system. The MTI ASCS, designed for unattended safe operation, will be capable of automatic startup and shutdown of the system. The MTI ASCS is designed for a 30-year life and has no planned maintenance for the components mounted on the dish. The MTI design is shown in figure 7.

STC CONCEPTUAL DESIGN

STC is the prime contractor and is responsible for both project management and the Stirling engine/hydraulic output design and system integration. STC has teamed with Sanders Associates for the receiver design, Gedeon Associates for analytical code validation, and Technology Dynamics, Inc., to augment STC's in-house heat pipe experience. The University of Washington provides the dynamic simulation and system design. Pioneer Engineering and Manufacturing Company will provide a manufacturing and cost analysis with a life cycle cost analysis of the conceptual design.

STC proposed using 25-kW, single-piston, Stirling hydraulic engine (STIRLIC^a) as the baseline design. This concept uses a Stirling hydraulic engine, shown in figure 8, mounted directly on the TBC while the remainder of the system is based on the ground. Use of developed commercial components were proposed for the ground based hardware to minimize development costs and reduce maintenance. The STIRLIC design is based on a 15-kW free-piston Stirling engine with an hydraulic output (described in ref. 6).

During the initial ASCS conceptual design phase the STC team reviewed a number of design options to meet the long-term cost and performance goals of DOE. Areas reviewed were -

- Optimum array size
- Conventional heater head (brazed) versus advanced annular heater head (welded)
- Reflux boiler versus heat pipe
- Material selection for long life
- Single-power piston versus opposed-power pistons
- Engine dynamic, scaling, and thermodynamic parameters
- Starter motor versus no starter motor

The STC "preliminary" conceptual design review was held in February 1987 at Lewis. The STC team presented a design which featured a Stirling engine with hydraulic output mounted on a TBC. A receiver concentrates the solar

^aOwner, Stirling Technology Company, Richland, Washington.

energy received from the collector and transfers it by conduction through a reflux boiler to the Stirling engine heater head operated at 800 °C. The engine is located off axis from the receiver cavity in order to maintain the heater tubes in vapor regardless of orientation. The liquid metal chosen for the reflux boiler is sodium. A conventional tubular heater head with an annular regenerator and cooler are used in this design. The helium working gas is hermetically sealed using a pair of nested bellows seals on the displacer. A scotch yoke-counter balance is used to maintain a precision top and bottom position of the displacer while significantly reducing the associated dead volumes. A starter motor is incorporated with the scotch yoke mechanism. The thermal energy is converted directly by the Stirling engine to hydraulic power through a pair of hermetically sealed power bellows. The two power bellows are identical and opposed for self-balancing. STC has demonstrated the potential for long life of the proposed pressure-balanced bellows systems in rigs and in their long-life artificial heart systems which are discussed in reference 7. The hydraulic power is transmitted on lines mounted directly on a TBC strut and routed to the ground-based conversion system. The STC design approach is to use an array of TBC's each mounted with a Stirling hydraulic engine capable of providing the necessary hydraulic power for 25 kW of electrical power on the ground. Four TBC's are used for a single array which provides hydraulic power to the common ground based system as shown in figure 9. The ground-based system includes a common accumulator with a single variable displacement hydraulic pump/motor, a rotary induction alternator with the necessary switch gear, and a common heat rejection system. The four Stirling hydraulic engines will be controlled by a common microprocessor. The STC Stirling hydraulic engine has been designed for a 30-year life and presently has no planned maintenance for the components mounted on the dish. The STC ASCS is designed for automatic startup and shutdown and is capable of unattended safe operation. The STC design is shown in figure 10.

STATUS

"Preliminary" conceptual designs of each ASCS have been completed by MTI and STC. A comparison of the ASCS designs are provided in table V. Both contractors are reviewing their designs to eliminate or reduce any unproven technologies. Also, each contractor is reducing the hot-end temperature from 800 to about 700 °C. The temperature reduction will increase material life and minimize potential liquid-metal capability problems. This temperature reduction may effect both power and efficiency for their ASCS.

The design changes will emphasize manufacturability and the potential for low cost while using existing technology available during the late 1980's. After completing each ASCS design in June, both conceptual designs will be frozen. Pioneer will make an independent evaluation of each design to assess manufacturability and provide a cost analysis using Pareto's Law (detailed costs of 20 percent of the ASCS critical parts). The Pioneer analysis is expected to be complete in September 1987 at which time DOE, SNLA, and NASA will make a selection of the ASCS for follow-on competitive procurement in late 1987 or early 1988.

CONCLUDING REMARKS

The Stirling engine has been identified by SNLA as one of the most promising heat engines for terrestrial applications. Free-piston technology currently being developed at Lewis for space and terrestrial applications has the potential to meet DOE's goals for both performance and cost. Common requirements for the space and terrestrial applications include high efficiency, high reliability, and very long life. Conceptual designs by STC and MTI each feature a Stirling engine, a receiver, and a means to provide about 25 kW of electric power to a utility grid while meeting DOE's long-term cost and performance goals. The MTI and STC conceptual designs are both unique and complementary. The MTI proposal incorporates a linear alternator to directly convert the energy to electricity, while STC generates electrical power indirectly by use of a hydraulic output to a ground-based hydraulic motor coupled to a rotating alternator. Both the MTI and STC concepts will be evaluated by the same but independent contractor to provide a manufacturing and cost analysis including life cycle cost. One of the conceptual designs will be selected for a competitive final design, hardware procurement, assembly, and test of the ASCS at the SNLA test facilities in Albuquerque, New Mexico, by 1990.

REFERENCES

1. Slaby, J.G.; and Alger, D.L.: 1987 Overview of Free-Piston Stirling Technology for Space Power Application. NASA TM-89832, 1987.
2. Walker, G.: Stirling Cycle Machines. Clarendon Press, Oxford, 1973, pp 121-127.
3. Anon.: Five Year Research and Development Plan 1986-1990. U.S. Department of Energy, DOE/CE-1060, Sept. 1986.
4. Shaltens, R.K.: Advanced Stirling Conversion Systems for Terrestrial Applications. NASA TM-88897, 1987.
5. Docat, G.; and Vitale, N.: Free-Piston Stirling Engines for Terrestrial Solar Electric Power Conversion. Advancing Toward Technology Breakout in Energy Conversion. (21st IECEC), Vol. 3, American Chemical Society, Washington, D.C., 1986, pp. 2055-2059.
6. White, M.A.: Conceptual Design and Cost Analysis of Hydraulic Output Unit for 15 kW Free-Piston Stirling Engine. NASA CR-165543, 1982.
- White, M.A.; Emigh, S.G.; and Riggle, P.: Practical Bellows Seals for Stirling Engines. SAE Paper 870104, Feb. 1987.

TABLE I - DOE COST^a GOALS

	Current technology	Long-term goals
Receiver	\$70/m ²	\$40/m ²
Transport	\$70/m ²	\$7/m ²
Conversion	\$380/kW _e	\$300/kW _e
Energy cost	0.13/kW _e	0.05/kW _e

^a1984 dollars.

TABLE II - SNLA TEST BED CONCENTRATOR (TBC) CHARACTERISTICS

Collector diameter, m	11.0
Focal length, m	6.6
Paraboloidal mounting structure, f/D	0.6
Reflectivity	0.89
Slew rates, deg/hr:	
Azimuth	2000
Elevation	200
Slope error, mrad	2
Input	75 kW _{th} at 950 W/m ²

TABLE III - ASCS DESIGN REQUIREMENTS

Heat engine - free-piston Stirling:
Engine/alternator system, < \$300/kW _e (1984 \$)
Heater head (metal) temperature, 800 °C
Thermal transport system - heat pipe
integral part of receiver:
Receiver aperture, 8.0 in.
Technology available in the late 1980's
Solar insulation, 950 W/m ² :
Survival to 1100 W/m ² for 15 min
ASCS weight: Not to exceed 2000 lb (907 kg)
Dynamic balance:
Maximum force not to exceed 150 lb (667 N)
ASCS design life:
30 yr (60,000 hr) with major overhaul
Engine design life with major overhaul:
30 yr (60,000 hr) with major overhaul at
20 yr (40,000 hr)
ASCS temperature range:
33 to -6.6 °C (92 to 20 °F)
Elevation:
5310 ft above sea level
Electrical output:
25 kW _e
120 V, 1 phase, 60 Hz or
240 V, 3 phase, 60 Hz
Power factor, not to exceed 0.85
Harmonic distortion, < 2.5 percent
System efficiency (solar to electric):
> 33 percent
Controls:
Fully automatic, unattended

TABLE IV - COMPARISON OF THE ASCS PROPOSALS

	MTI	STC
Heat supplied, kW _{th}	75	75
Electric power, kW _e	25.0	24.8
Efficiency (solar to electric), percent	33.3	33.1
Heat pipe heater	Yes	Yes
Heater temperature (metal), K(°C)	1073(800)	1073(800)
Cooler temperature K(°C)	346(73)	323(50)
Temperature ratio, T _h /T _c	3.1	3.3
Working fluid	Helium	Helium with Freon buffer
Working pressure, bar	100	138
Weight (on TBC), kg(lb)	907(2000)	82(181)
Annual power, kW-hr	58,666	61,940

TABLE V - COMPARISON OF ASCS CONCEPTS
(MARCH 1987)

	MTI	STC
Heat supplied, kW _{th}	75	75
Electric power, kW _e	26.5	26.8
Efficiency (solar to electric), percent	35.3	35.7
Efficiency engine (Q _{in} to PWR _{out}), percent	45.2	44.3
Receiver/liquid metal	Heat pipe/ sodium	Reflux boiler/ sodium
Heater head temperature, K (°C)	1073(800)	1073(800)
Cooler temperature, K (°C)	333(60)	323(50)
Temperature ratio, T _h /T _c	3.2	3.3
Working fluid	Helium	Helium with Freon buffer
Annual power (est.), kW-hr	70,000	62,000

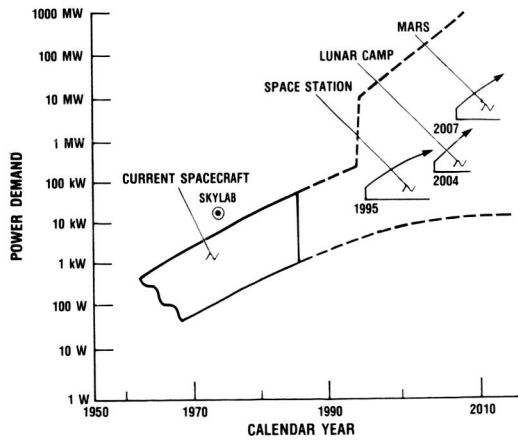

FIGURE 1. - PLANNED SPACE POWER PROGRAMS ADDRESS GROWTH.

**ORIGINAL PAGE IS
OF POOR QUALITY**

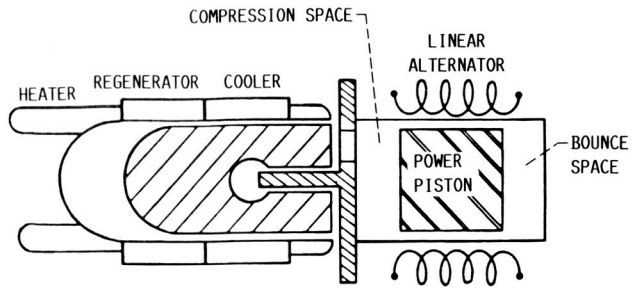

FIGURE 2. - FREE-PISTON STIRLING ENGINE WITH LINEAR ALTERNATOR.

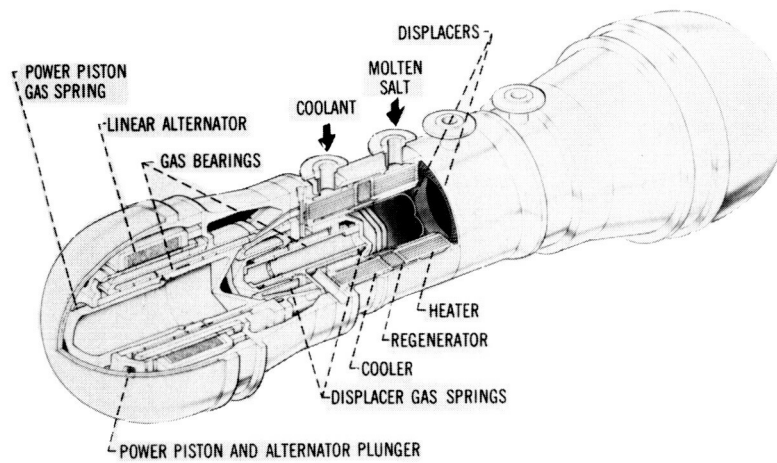

FIGURE 3. - 25-kW_e SPACE POWER DEMONSTRATOR ENGINE.

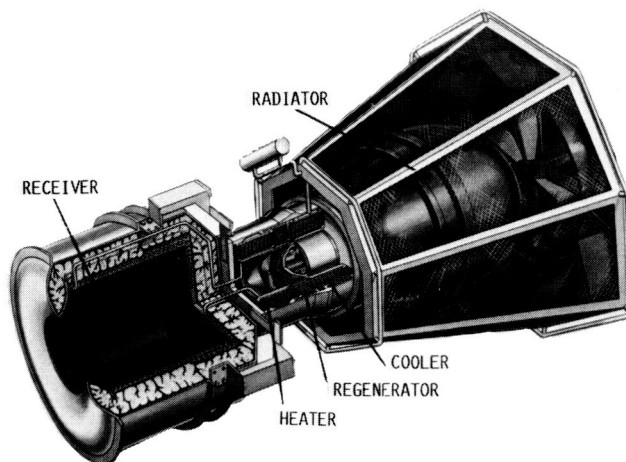

FIGURE 4. - CONCEPTUALIZED FREE-PISTON STIRLING ENGINE CONVERSION SYSTEM.

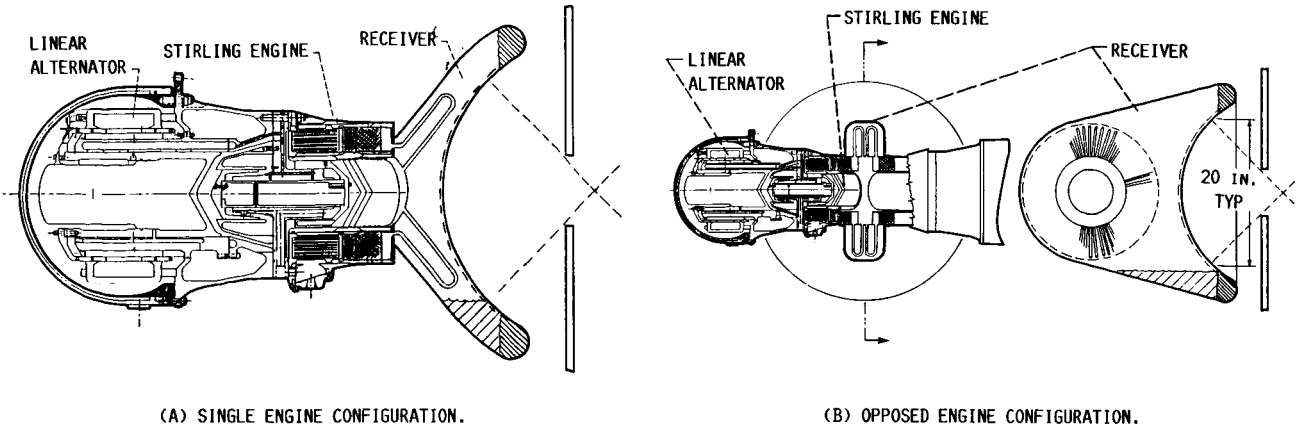

FIGURE 5. - MTI'S PROPOSED CONCEPTS.

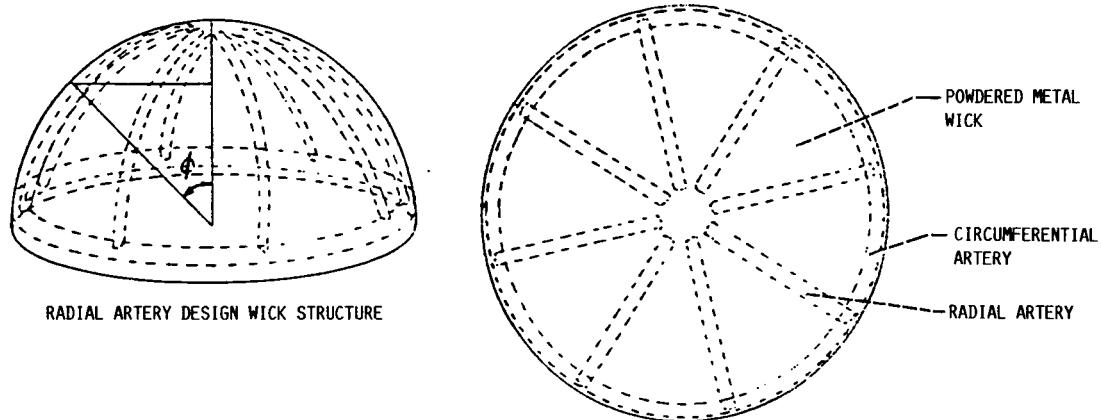

FIGURE 6. - MIT'S DISH SHAPED HEAT PIPE WITH ARTERIES.

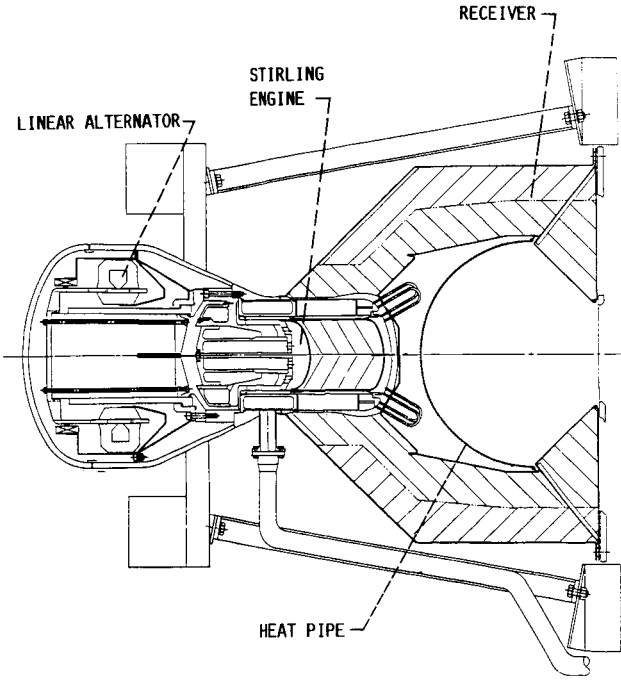

FIGURE 7. - MTI'S SINGLE-PISTON STIRLING ENGINE CONFIGURATION.

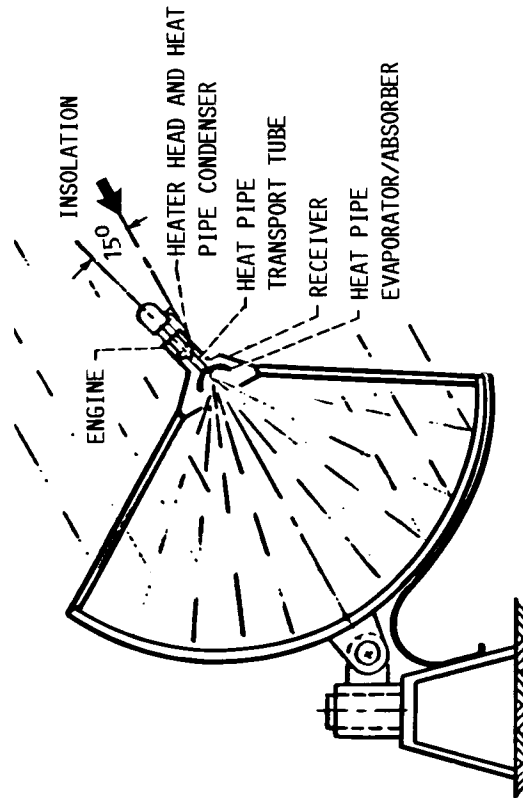
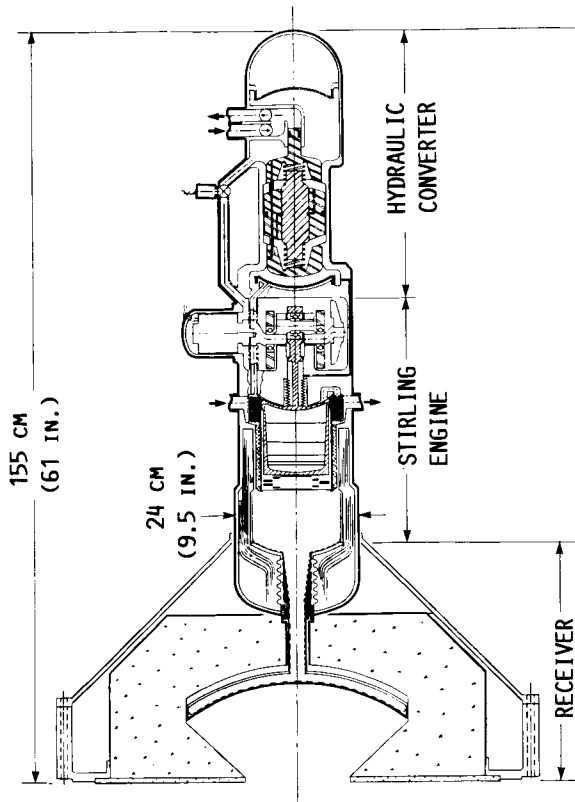

FIGURE 8. - STC'S PROPOSED DESIGN ON THE TBC.

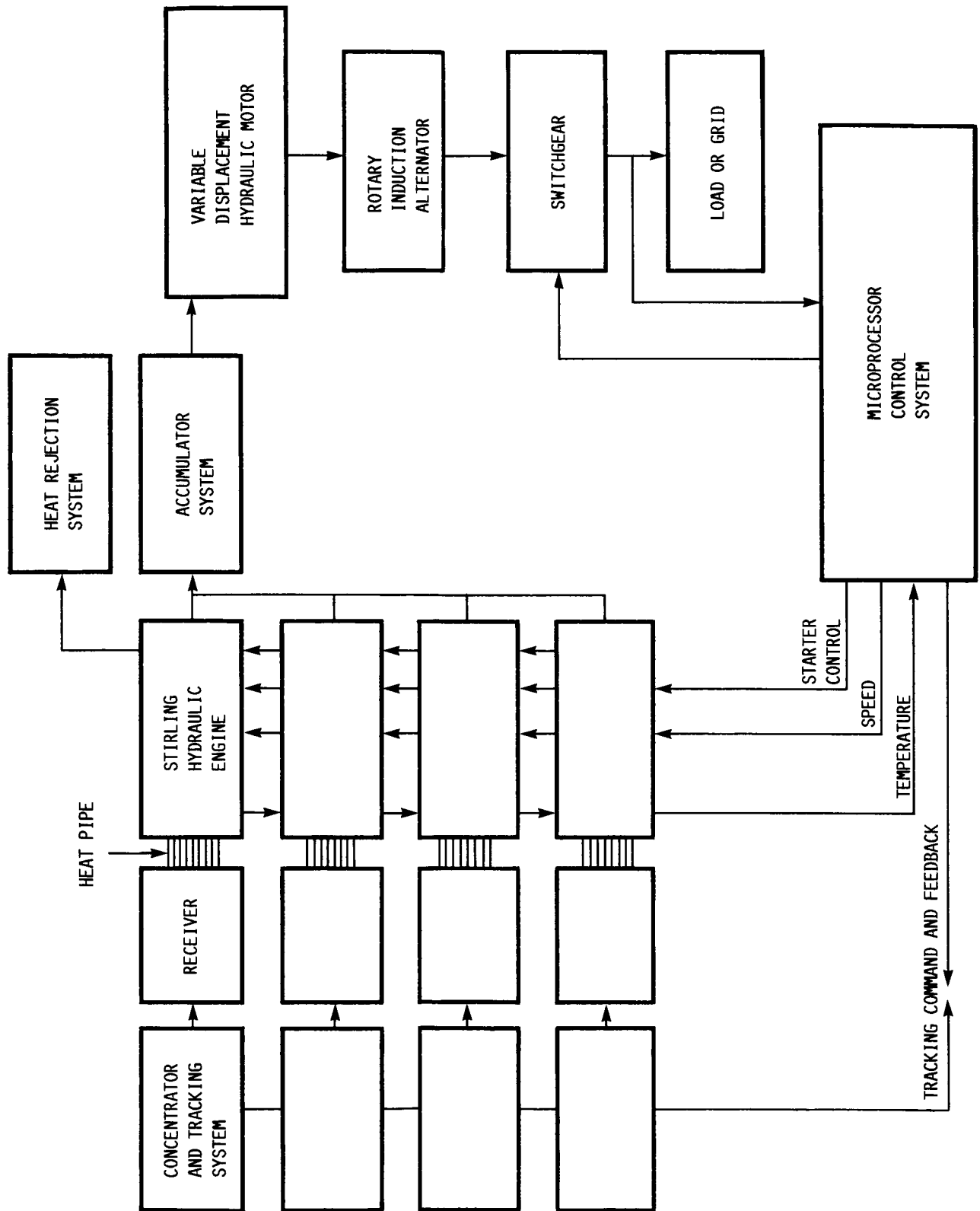

FIGURE 9. - STC'S BLOCK DIAGRAM FOR A SINGLE ARRAY.

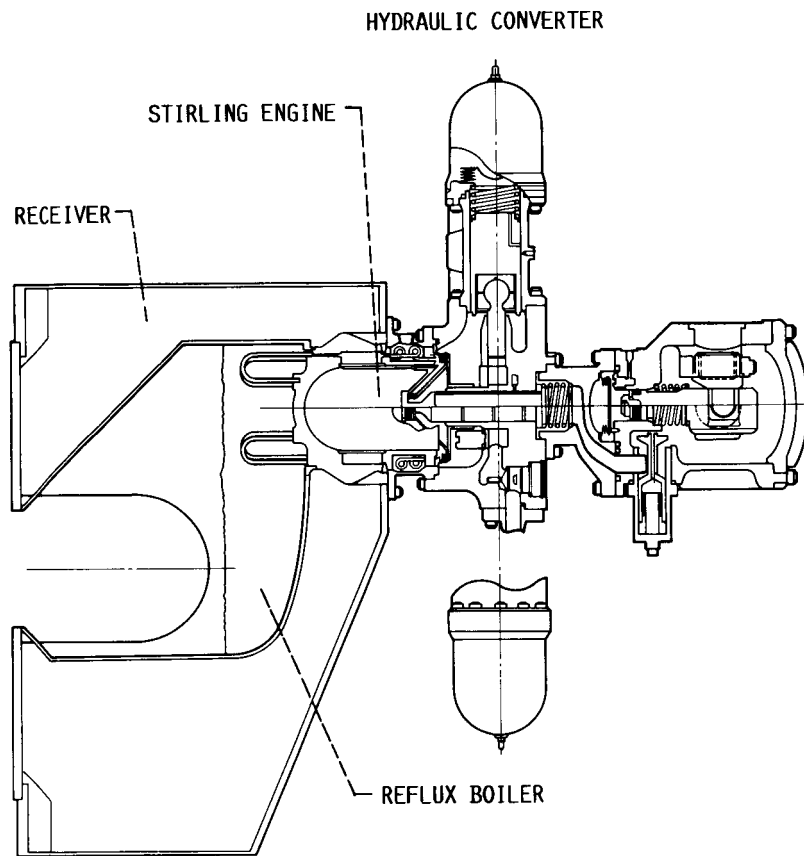

FIGURE 10. - STC'S STIRLING ENGINE WITH HYDRAULIC OUTPUT.



Report Documentation Page

1. Report No. NASA TM-100111 AIAA-87-9069		2. Government Accession No.		3. Recipient's Catalog No.	
4. Title and Subtitle Comparison of Stirling Engines for Use with a 25-kW Disk-Electric Conversion				5. Report Date	
				6. Performing Organization Code	
7. Author(s) Richard K. Shaltens				8. Performing Organization Report No. E-3655	
				10. Work Unit No. 776-81-63	
9. Performing Organization Name and Address National Aeronautics and Space Administration Lewis Research Center Cleveland, Ohio 44135				11. Contract or Grant No.	
				13. Type of Report and Period Covered Technical Memorandum	
12. Sponsoring Agency Name and Address National Aeronautics and Space Administration Washington, D.C. 20546				14. Sponsoring Agency Report No. DOE/NASA/33408-2	
				15. Supplementary Notes Final Report. Prepared under Interagency Agreement DE-AT04-85AL33408. Prepared for the 22nd Intersociety Energy Conversion Engineering Conference, cosponsored by the AIAA, ANS, ASME, SAE, IEEE, ACS, and AIChE, Philadelphia, Pennsylvania, August 10-14, 1987.	
16. Abstract <p>The Department of Energy's (DOE) Solar Thermal Technology Program, Sandia National Laboratories (SNLA), is evaluating heat engines for terrestrial solar distributed heat receivers. The Stirling engine has been identified by SNLA as one of the most promising engines for terrestrial applications. The potential to meet DOE's goals for performance and cost can be met by the free-piston Stirling engine. NASA Lewis is providing technical management for an Advanced Stirling Conversion System (ASCS) through a cooperative Interagency Agreement with DOE. Parallel contracts have been awarded to Mechanical Technology, Inc. (MTI) of Latham, New York, and Stirling Technology Company (STC) of Richland, Washington, for the conceptual designs of an ASCS. Each design will feature a free-piston Stirling engine, a liquid-metal heat pipe receiver, and a means to provide about 25 kW of electric power to a utility grid while meeting DOE's long-term performance and cost goals. The MTI design incorporates a linear alternator to directly convert the solar energy to electricity while STC generates electrical power indirectly by using a hydraulic output to a ground-based hydraulic pump/motor coupled to a rotating alternator. Both designs for the ASCS's will use technology which can reasonably be expected to be available in the 1980's. Both the MTI and STC concepts will be evaluated by the same, but independent, contractor to provide a manufacturing and cost analysis including life cycle cost. The ASCS designs using a free-piston Stirling engine, a heat transport system, a receiver, and the methods of providing electricity to the utility grid will be discussed.</p>					
17. Key Words (Suggested by Author(s)) Advanced Stirling conversion system Free-piston Stirling engine Terrestrial solar distributed heat receivers			18. Distribution Statement Unclassified - unlimited Subject Category 85 DOE Category UC-96		
19. Security Classif. (of this report) Unclassified		20. Security Classif. (of this page) Unclassified		21. No of pages 15	22. Price* A02