

NASA Technical Memorandum 88272

---

# Aircraft Ground Vibration Testing at NASA Ames-Dryden Flight Research Facility

---

Michael W. Kehoe

---

(NASA-TM-88272) AIRCRAFT GROUND VIBRATION N87-27655  
TESTING AT NASA AMES-DRYDEN FLIGHT RESEARCH  
FACILITY (NASA) 21 p Avail: NTIS HC  
AG2/MF A01 CSCL 01C  
G3/05 Unclass  
0093093

July 1987

---

# Aircraft Ground Vibration Testing at NASA Ames-Dryden Flight Research Facility

---

Michael W. Kehoe  
Ames Research Center, Dryden Flight Research Facility, Edwards, California

1987



National Aeronautics and  
Space Administration

**Ames Research Center**

Dryden Flight Research Facility  
Edwards, California 93523-5000

---

# AIRCRAFT GROUND VIBRATION TESTING AT NASA AMES-DRYDEN FLIGHT RESEARCH FACILITY

Michael W. Kehoe  
NASA Ames Research Center  
Dryden Flight Research Facility  
Edwards, California, U.S.A.

## ABSTRACT

At the NASA Ames Research Center's Dryden Flight Research Facility at Edwards Air Force Base, California, a variety of ground vibration test techniques have been applied to an assortment of new or modified aerospace research vehicles. This paper presents a summary of these techniques and the experience gained from various applications. The role of ground vibration testing in the qualification of new and modified aircraft for flight is discussed. Data are presented for a wide variety of aircraft and component tests, including comparisons of sine-dwell, single-input random, and multiple-input random excitation methods on a JetStar airplane.

## INTRODUCTION

Ground vibration testing is performed on a structure to identify its structural modes and their associated natural frequencies and dampings. This type of testing is an important part of the flight test activity at the Dryden Flight Research Facility of NASA's Ames Research Center (Ames-Dryden). The reasons for its important role in flight test include correlating and verifying the test modal data with dynamic finite-element models used to predict potential structural instabilities (such as flutter),<sup>(1,2)</sup> assessing the significance of modifications to research vehicles by comparing the modal data before and after the modification,<sup>(3)</sup> and helping to resolve in-flight anomalies.<sup>(4)</sup>

Ground vibration testing may involve the complete airplane mounted on a soft support system to simulate a free-free condition, the complete airplane resting on its landing gear, specific parts on the complete airplane, or single components, such as landing gear doors or control surfaces.

Before describing some typical test results, a brief description of the Ames-Dryden ground vibration testing capabilities is presented.

## TEST EQUIPMENT

Ground vibration tests are conducted using the sine-dwell excitation method, single- and multiple-input random excitation methods, or the impact excitation method. Some equipment is common to all the methods of excitation, whereas some is unique to a method. The use of electrodynamic shakers with force ratings of 10, 50, and 150 lb (Fig. 1) is common to all

the methods except impact excitation. Each shaker is attached by means of a telescoping thrust rod and a mechanical fuse. The fuse is attached to a locking swivel assembly, which is either bolted or bonded directly to the structure. A typical shaker attachment is shown in Fig. 2.

Accelerometers weighing 2 oz and having a sensitivity of 500 mV/g are used for most airplane tests. Smaller accelerometers weighing 0.32 oz and having a sensitivity of 10 mV/g are used for light structures and small components.

## SINE-DWELL TEST EQUIPMENT

The sine-dwell excitation equipment is housed in two portable consoles (Fig. 3). This system is capable of providing swept-sine excitation while simultaneously acquiring, filtering, recording, and displaying six channels of accelerometer data. The total number of accelerometers available to the system is 24. A switching box allows for changing to different sets of six accelerometers. The amplified accelerometer signals have a 2.0-Hz bandwidth tracking filter. A patch panel is utilized to route the signal to several common display and recording devices, such as X-Y plotters and a stripchart recorder. A coincident-quadrature (co-quad) analyzer is also part of this system.

## RANDOM TEST EQUIPMENT

The random excitation equipment consists of a minicomputer-based system housed in one portable console (Fig. 4). The system is capable of acquiring, filtering, displaying, and recording eight channels of accelerometer data. The system has software that is capable of analyzing vehicle responses from swept-sine, random, and impact excitation.

## IMPACT TEST EQUIPMENT

The impact excitation equipment consists of a hammer instrumented with a force transducer and interchangeable heads of different hardnesses. The heads are made of rubber, plastic, and metal. The accelerometer amplifier, force transducer amplifier, and hammer are shown in Fig. 5.

## TEST PROCEDURES

### SINE-DWELL EXCITATION TECHNIQUE

The sine-dwell excitation technique uses two or more shakers to excite the elastic modes of the

vehicle. Frequency sweeps generally are conducted over the frequency range of interest. Accelerometers are placed at several locations and in various orientations on the vehicle. The frequency response plots of these accelerometers are recorded on X-Y plotters. These plots identify the approximate frequencies at which significant structural response occurs.

After the frequency sweeps are completed, each aircraft structural mode of interest is fine tuned by using a co-quad analyzer with one acceleration and one force signal as inputs. Each mode is tuned by minimizing the coincident (in-phase) component and maximizing the quadrature (out-of-phase) component of the signal. To check on the quality of the mode, electrical power to the shaker is terminated, and the decay traces of selected accelerometer responses are observed to detect beats. The absence of beats in the decay traces indicates that a mode is properly tuned. Sometimes the shakers must be relocated to achieve acceptable tuning for a particular mode.

Once a mode is tuned, a modal survey is performed with roving accelerometers. The point on the structure with the largest amplitude is selected as the reference point. The reference is used to normalize all other accelerometer response values and to determine phase relationships.

#### RANDOM EXCITATION TECHNIQUE

For the random excitation technique, the structural analysis system first generates a random forcing function of a bandwidth and amplitude specified by the user. The forcing function is generated with the aircraft in the loop and recorded on a tape recorder, as shown in Fig. 6. The signal is then played back through the electrodynamic shaker attached to the airplane. Data are then acquired with the structural analysis system at each accelerometer location on the vehicle. Figure 7 illustrates this process. Transfer and coherence functions are calculated for each response with a frequency bandwidth that is wide enough to include all the modes of interest. The coherence function is used as a measure of the quality of the data before they are stored on the system disk. Leakage errors are reduced by using a Hann window or by using burst random excitation.(5)

Once data acquisition is completed for the entire airplane, modal parameters are estimated with either the complex exponential or the Polyreference (General Electric CAE International) parameter estimation techniques.(6) Each technique solves for the modal parameters in the time domain. A single response function is operated on by the complex exponential technique to obtain the modal parameters. Multiple response functions are manipulated by the Polyreference technique to obtain global least-squares estimates of the modal parameters.

Two single-degree-of-freedom techniques, least squares circle fitting(6) and total response, are available for the estimation of mode shapes. A

multiple-degree-of-freedom curve-fitting technique is also available.

#### IMPACT EXCITATION TECHNIQUE

Impact excitation is used primarily for component testing. The test structure is excited by an instrumented hammer. The response signal decay is multiplied by an exponential window to reduce leakage. The data analysis is the same as for the random excitation technique.

#### SOFT SUPPORT SYSTEMS

Soft support systems are used to simulate a free-free condition and to reduce the frequency of the rigid-body modes. At Ames-Dryden these systems include an overhead airbag for vehicles with gross weights under 4000 lb and under-the-gear airbags for vehicles with gross weights up to approximately 100,000 lb. A third type of soft support can be effected by allowing the vehicle's landing gear to rest directly on the floor.

The overhead airbag system (Fig. 8) consists of an airbag that is enclosed in a framework to provide fail-safe support should the airbag fail or depressurize. The vertical plunge frequency of this system is 1.9 Hz. This system is usually attached to the center-of-gravity point on a vehicle, and elastic cord must be attached to the vehicle to prevent it from moving.

The under-the-gear airbag system (Fig. 9) consists of three landing gear support units. Each unit has a single airbag enclosed within a framework and an aluminum plate that sets on top of each framework. To keep the nonlinear tire dynamics from affecting test results and to improve the stability of each individual airbag unit, fixtures can be installed on each top plate so that a landing gear axle can be attached directly to the unit. Since the airbags are not designed to support lateral or longitudinal motion, the vehicle must be stabilized by attaching cables from each landing gear to the floor. The vertical plunge frequency of this system is 1.6 Hz.

Some tests are conducted with the vehicle's landing gear resting directly on the floor (Fig. 10). In this configuration, the landing gear oleo struts are deflated to reduce potential nonlinear oscillations, and the tire pressure is reduced to one-half normal to provide a soft support. This approach should be used with considerable caution because the rigid-body landing gear modes may be inadequately isolated from the flexible-body dynamic modes.

#### EXAMPLE GROUND VIBRATION TESTS

##### HiMAT VEHICLE

The highly maneuverable aircraft technology (HiMAT) program involved two remotely piloted vehicles incorporating several new technologies. These technologies included composite structure, aeroelastic tailoring, supercritical airfoil,



close-coupled canard, variable-camber wing, digital flight controls, and relaxed static stability.

A ground vibration test (Fig. 11) was conducted prior to flight testing so that the finite-element model used in the flutter analysis could be updated based on ground vibration test results.(2) The sine-dwell technique, using an overhead airbag for soft support, was used to determine the modal parameters. The vehicle hydraulic system was on for the test. There were 164 survey points on the vehicle. Up to seven shakers were used simultaneously to obtain good excitation for some modes. Forty-six modes were surveyed in an eight-week time period.

During initial ground testing, it became apparent that free play was affecting the responses of the control surfaces. The amount of free play was reduced by eliminating hydraulic actuator valve movement through additional electronic control of the hydraulic unit. Free play was further reduced by preloading the control surfaces with elastically suspended masses. This was accomplished by suspending a 10-lb can of lead shot by an elastic cord. The fundamental natural frequency of each spring-mass system was below 2.0 Hz. The effect of the suspended mass on the modal response of the elevons is shown in Fig. 12. The suspended mass had the desired effect of considerably improving the response peaks of the fundamental elevon mode while not significantly altering the fundamental wing modes.

Orthogonality checks were performed to determine the quality of each mode shape. Very good orthogonality was obtained for all modes.

#### X-29A FORWARD-SWEPT-WING AIRPLANE

During the initial flight testing of the X-29A airplane, the stability of the critical midflap-eron torsion flutter mode could not be tracked in flight. The flaperon system on the X-29A was a double-hinged configuration, as shown in Fig. 13. An initial ground vibration test was conducted,(7) and the midflap-eron torsion mode was measured at a frequency of 38.7 Hz. However, this test was conducted without the hinge aerodynamic seals in place. Once in place, these seals apply considerable force on the flaperon near the hinge line.

A second limited ground vibration test was conducted with the seals in place to determine the effects of the seals on the flaperon torsion mode frequency. During this ground vibration test, the free play of the flaperon affected the response of this mode. Since there was no way of practically removing the free play from these surfaces, the free play was reduced by preloading the outboard and midflap-erons each with 50 lb and the inboard flaperon with 100 lb suspended from elastic chords (Fig. 14). The frequency of each spring-mass system was approximately 1.0 Hz. It should be noted that 100 lb of preload was suspended from the wing, which weighed approximately 800 lb. The preload had the desired effect of improving the response amplitude and phase of the

midflap-eron mode (Fig. 15) while not affecting the frequency or amplitude of the wing mode.

This test illustrates the use of ground vibration testing to investigate in-flight data anomalies and also the effect of a large amount of elastically suspended mass on the response of a complex control surface.

#### JETSTAR LAMINAR FLOW CONTROL AIRPLANE

To demonstrate the effectiveness of laminar flow control under flight conditions representative of commercial transport operation, a JetStar airplane was extensively modified. Wing modifications included removal of external fuel slipper tanks and installation of a leading edge test section on each wing. Each wing's test section was of a different design. The gap in the trailing edge flap left by the tank removal was closed. Figure 16 shows the airplane modifications.

In preparation for initial flight tests, a ground vibration test was conducted to identify and define the structural modes of the modified airplane. The vehicle's landing gear rested directly on the floor during this test. The landing gear struts were deflated, and the tire pressure was reduced to one-half normal.

The test was conducted initially using the sine-dwell method and was repeated using single-input random excitation.(3) The modal parameters were calculated using the complex exponential parameter estimation technique. A modal assurance criterion (MAC),(6) which can be used as an approximation of an orthogonality check, was used to compare the mode shapes from sine-dwell and single-input random methods. The MAC values for several of the elastic modes are shown in Table 1. Values above 0.90 indicate close agreement between mode shapes. The frequency, damping, and mode shape plot comparisons are given in Fig. 17.

Approximately one year after the initial ground vibration test, the capability of conducting multiple-input random testing became available. This method achieves a better excitation energy distribution than that obtained with the single-input random method. To obtain a comparison of the sine-dwell, single-input random, and multiple-input random methods, a second ground vibration test was conducted on the JetStar airplane. Modal data were acquired using the burst multiple-input random excitation technique. The Polyreference parameter estimation technique was used to calculate the modal parameters. The MAC was used to compare several mode shapes of the sine-dwell and multiple-input random methods. The MAC values for multiple-input random excitation are given in Table 2. The MAC values were closer to a value of 1.00 for these modes than the MAC values for the single-input random method, indicating that a better energy distribution was obtained with multiple-input random excitation. The mode shapes obtained with the multiple-input random excitation also agreed better with the sine-dwell mode shapes. The frequency, damping, and mode shape plot com-

parisons of multiple-input random and sine-dwell methods are shown in Fig. 18.

#### F-14 NATURAL LAMINAR FLOW AIRPLANE

The objective of the F-14 natural laminar flow program was to measure the effects of wing sweep on boundary layer transition from laminar to turbulent flow. For this experiment, a foam-fiberglass glove was applied over a portion of one wing (Fig. 19). The aeroelastic concerns for this modification were whether the resulting changes in wing weight, wing stiffness, and airfoil shape could be sufficient to adversely affect the aircraft's aeroelastic stability characteristics. The approach taken to qualify this modification for flight was to conduct a ground vibration test before and after glove installation. Modal parameters, including mode shapes, were then compared to determine if there were any significant changes.

Since the measured modal data were not being compared with a finite-element vibration analysis, the single-input random method was deemed the simplest and fastest method to acquire and analyze the data. The modal parameters were estimated from frequency response functions using the complex exponential method. The soft support used for these tests was the airplane's landing gear, with deflated gear struts and tires at one-half normal pressure, resting directly on the floor. There were 55 survey locations on the airplane, and 17 modes were measured. Each ground vibration test was accomplished in approximately 16 hr, which did not include data analysis. Another 16 hr were required for data analysis.

A comparison of frequency response functions for the wing with and without the glove is shown in Fig. 20. The comparison indicated small shifts in the wing-bending natural frequencies. Also noted was a new mode for the gloved wing at 21.3 Hz. This was a torsion mode of the gloved wing only and was higher in frequency than the torsion mode of the unmodified wing.

After completion of the ground vibration test, a flight flutter program was successfully conducted. The F-14 laminar flow program is an example of qualifying an airplane for flight by using ground vibration testing to determine the change in modal characteristics as a result of a structural modification.

#### RSRA LANDING GEAR DOOR

The rotor systems research aircraft (RSRA) is designed to operate as a helicopter, as a compound helicopter (with fixed wings and auxiliary jet engines), and as a fixed-wing vehicle. The RSRA is a unique research vehicle for in-flight investigation and verification of new helicopter rotor system concepts and supporting technology. The vehicle in the fixed-wing configuration is shown in Fig. 21.

On a flight in the compound configuration (prior to arriving at Ames-Dryden), the left landing gear

door detached from the vehicle while the landing gear was in the extended position.

The left landing gear door, designed as a single unit of fiberglass construction, was modified by adding layers of fiberglass in the area of the gear door strut attachment. The door was also stiffened by the addition of an aluminum bar connecting the top and bottom of the door at the aft end.

Before flight testing the fixed-wing configuration at Ames-Dryden, a flutter and divergence analysis was performed for the door. To correlate modal data with the finite-element analysis, a ground vibration test was conducted using impact excitation at 64 locations on the door (Fig. 22). Frequency response functions were calculated to extract modal parameters using the complex exponential method. The mode shape coefficients were calculated using the total response technique. Test setup (which included movement of the equipment to the RSRA hangar), data acquisition, and data analysis for five elastic modes was accomplished in 6 hr.

#### F-15 SUPERSONIC NATURAL LAMINAR FLOW WING

The objective of the F-15 supersonic natural laminar flow program was to obtain accurate in-flight measurements of laminar to turbulent boundary layer transition at supersonic speeds. The approach was to add a foam-fiberglass upper wing surface test section that was 4 ft square. Figure 23 shows a typical wing cross section with the glove.

The laminar flow test section was placed in front of the right aileron. The concern from an aeroelastic standpoint was the effect of the test section on aileron single-degree-of-freedom flutter (buzz) at transonic and low supersonic airspeeds. There was concern that the test section could change the oscillating shock wave position or phase, or both, with respect to the aileron and that an instability could result.

To monitor the aileron's stability in flight, an accelerometer was mounted on the outboard trailing edge of the right aileron. The airplane was flown to Mach 1.5 during the initial flights. The aileron did not buzz, but a small-amplitude sinusoidal oscillation at a frequency much higher than the aileron rotation frequency was observed (Fig. 24).

The oscillation was assumed to be a skin resonance. To test this assumption and to determine if the accelerometer had been placed at a point where maximum deflection occurred (because there were no available ground vibration test data for the aileron attached to the wing), it was decided to conduct an aileron ground vibration test using impact excitation (Fig. 25) and extracting modal parameters from frequency response functions. These data showed that the oscillation was an aileron higher order flexible mode (Fig. 26) and also indicated that the accelerometer should be moved forward 5 in. to measure the point of maximum deflection.

This test illustrates the use of ground vibration testing as a means of explaining in-flight data anomalies discovered during flight testing.

#### CONCLUSIONS

Ground vibration testing has an important role in qualifying aircraft for flight, in providing data to correlate with finite-element models, and in resolving in-flight data anomalies. A summary of test equipment, test techniques, and experiences associated with ground vibration testing was presented in this paper.

Sine-dwell, single- and multiple-input random, and impact excitation methods are all used at Ames-Dryden. Each method has advantages and disadvantages, and no one method is solely relied upon for all testing. The unique nature of experimental research aircraft and their modifications require that a variety of methods be available to the researcher.

#### REFERENCES

1. Lenzi, David C., and Cogburn, Lowell T., "AFTI/F-111 Mission Adaptive Wing Ground Vibration Test," AFFTC-TR-85-1, Air Force Flight Test Center, Edwards Air Force Base, California, Feb. 1985.
2. Coombs, David C., "Ground Vibration Test of the Highly Maneuverable Aircraft Technology (HiMAT) Vehicle," AFFTC-TR-78-31, Air Force Flight Test Center, Edwards Air Force Base, California, Mar. 1979.
3. Kehoe, Michael W., Crazier, F.W., Jr., and Ellison, Joseph F., "Ground Vibration Test of the Laminar Flow Control JetStar Airplane," NASA TM-86398, 1985.
4. Kehoe, Michael W., and Ellison, Joseph F., "Flutter Clearance of the Schweizer 1-36 Deep-Stall Sailplane," NASA TM-85917, 1985.
5. Olsen, Norm, "Burst Random Excitation," Sound and Vibration, Nov. 1983, pp. 20-23.
6. "User Manual for Modal Analysis 8.0," General Electric CAE International, 1983.
7. Flynn, J., Martone, E., and Anderson, P., "Results of the Ground Vibration Survey (GVS)/Integrated Flight Control System (FCS) Tests of the X-29 Aircraft," 712/ENG-RPT-85-006, Grumman Aerospace Corporation, Bethpage, New York, Dec. 1985.

Table 1 Comparison of mode shapes from sine-dwell and single-input random tests on a JetStar airplane

Mode number	Sine-dwell frequency, Hz	Single-input frequency, Hz	Modal assurance criterion
1	4.90	4.92	0.98
2	5.05	5.20	0.94
3	5.75	5.97	0.92

Table 2 Comparison of mode shapes from sine-dwell and multiple-input random tests on a JetStar airplane

Mode number	Sine-dwell frequency, Hz	Multiple-input frequency, Hz	Modal assurance criterion
1	4.90	4.92	0.99
2	5.05	5.13	0.99
3	5.75	5.87	0.98

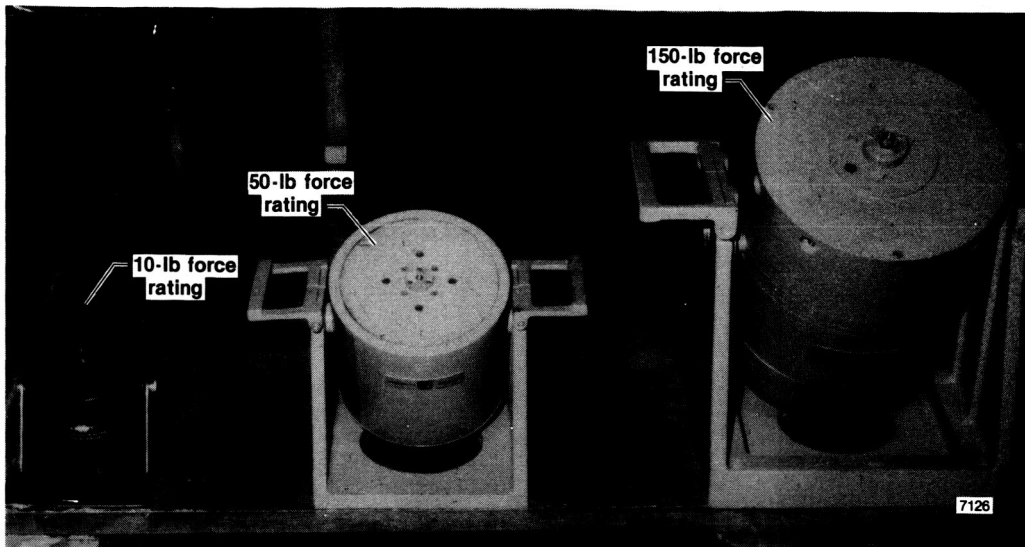
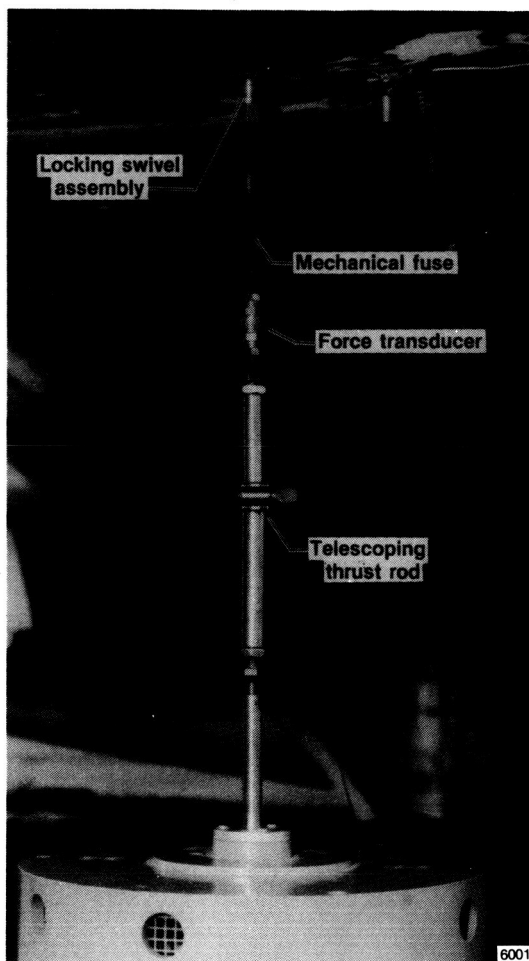

Fig. 1 Electrodynamic shakers.

ORIGINAL PAGE IS  
OF POOR QUALITY



ORIGINAL PAGE IS  
OF POOR QUALITY

Fig. 2 Electrodynamic shaker attachment hardware.

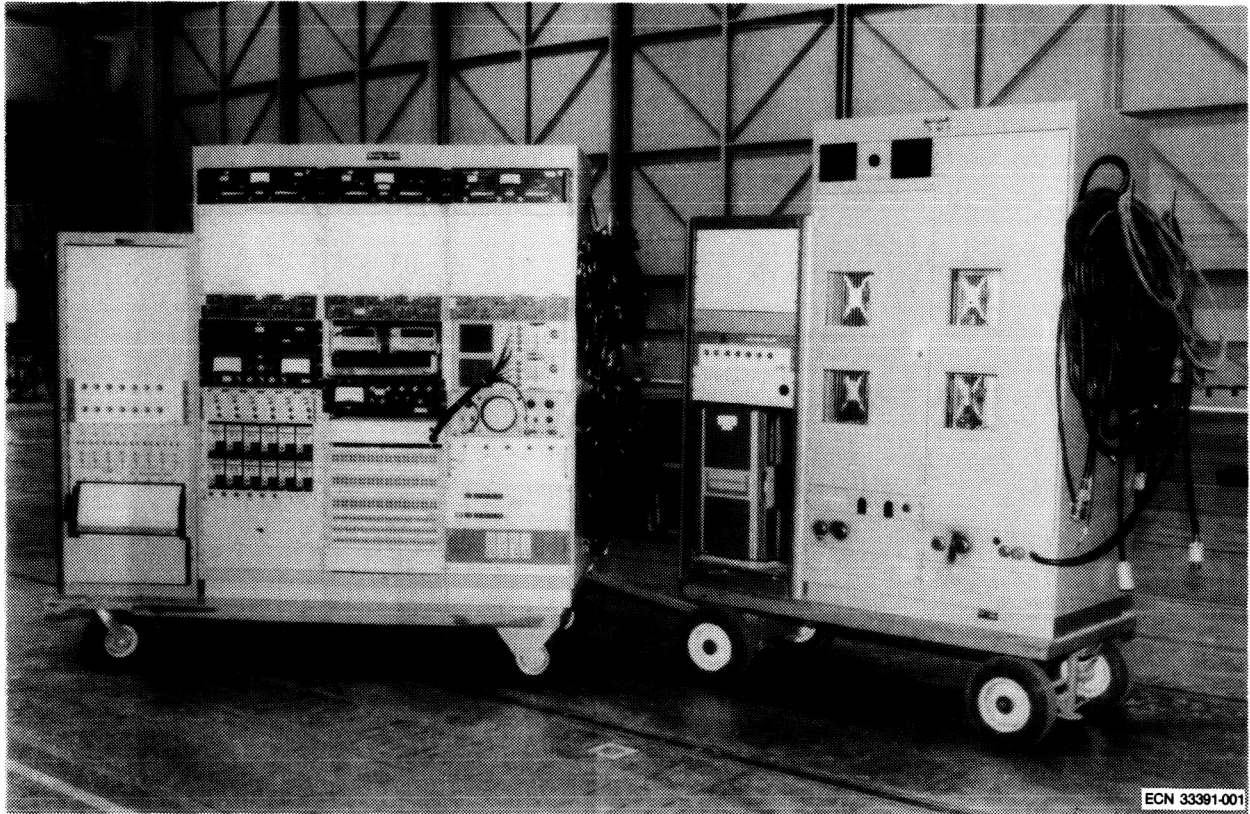

*Fig. 3 Sine-dwell equipment consoles.*



*Fig. 4 Minicomputer-based structural analysis system.*



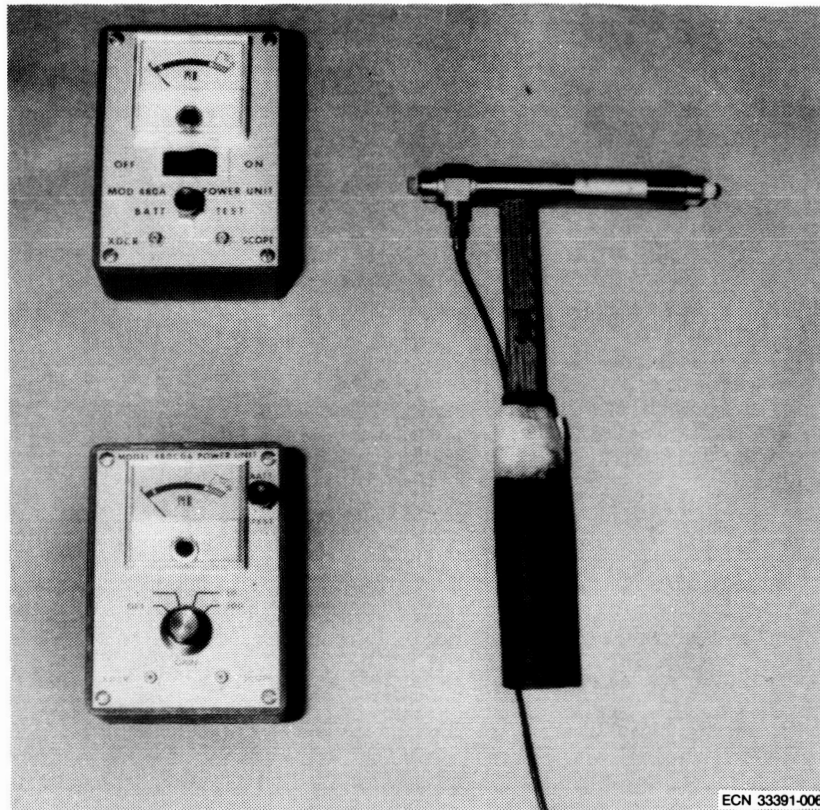
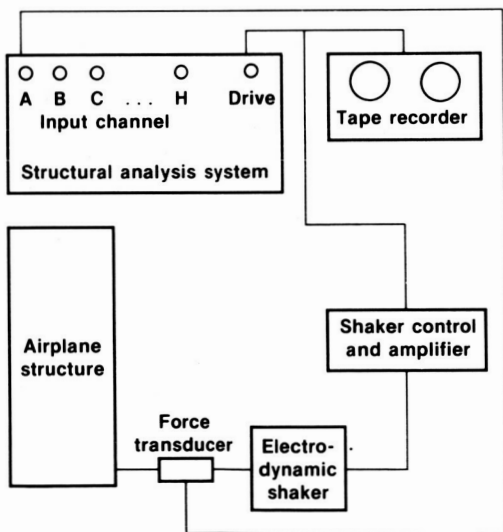
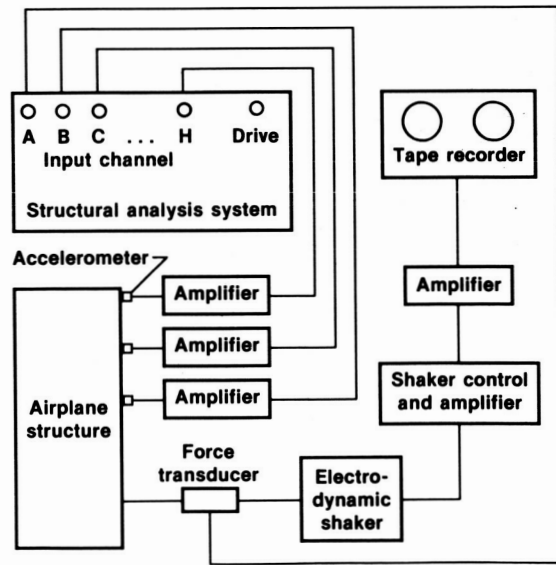

Fig. 5 Instrumented hammer and transducer amplifiers.



6002

Fig. 6 Schematic of the minicomputer-based structural analysis system for forcing-function generation.



6003

Fig. 7 Schematic of the minicomputer-based structural analysis system for random excitation and data acquisition.

ORIGINAL PAGE IS  
OF POOR QUALITY

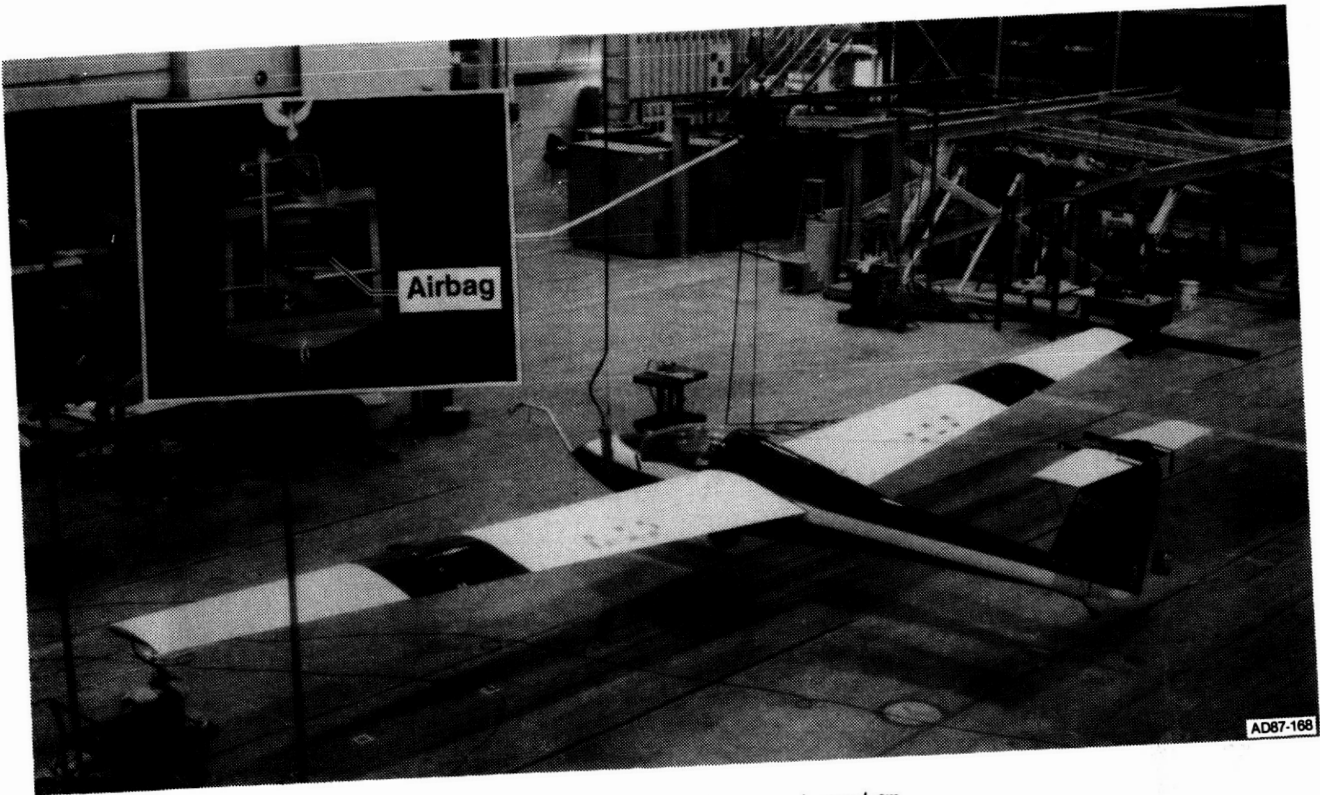
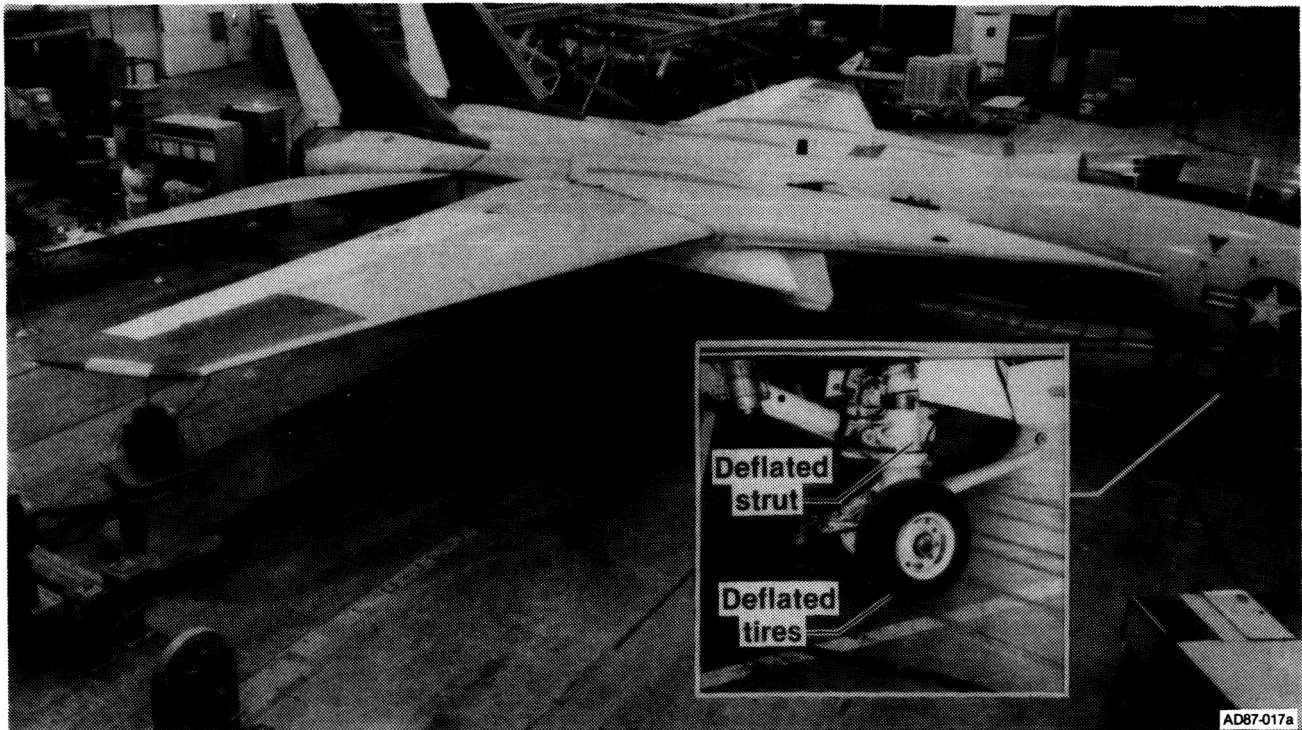

Fig. 8 Overhead soft support system.

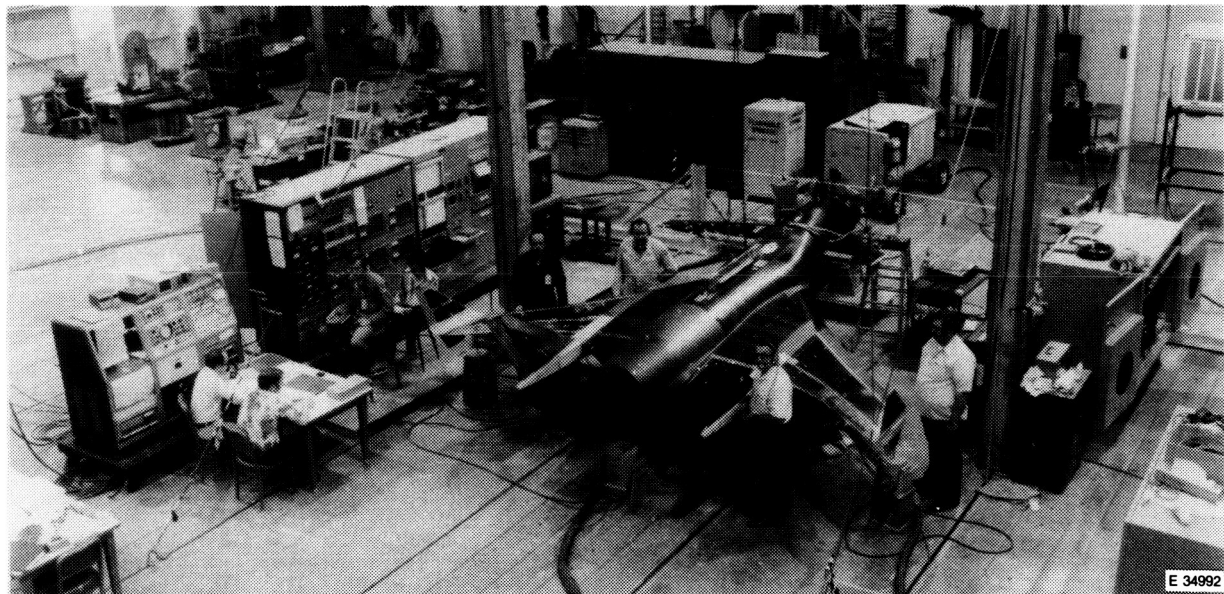

Fig. 9 Under-the-gear soft support.

210 3109 4-



*Fig. 10 Soft support using the vehicle landing gear.*



*Fig. 11 HiMAT ground vibration test.*

**ORIGINAL PAGE IS  
OF POOR QUALITY**



ORIGINAL PAGE IS  
OF POOR QUALITY

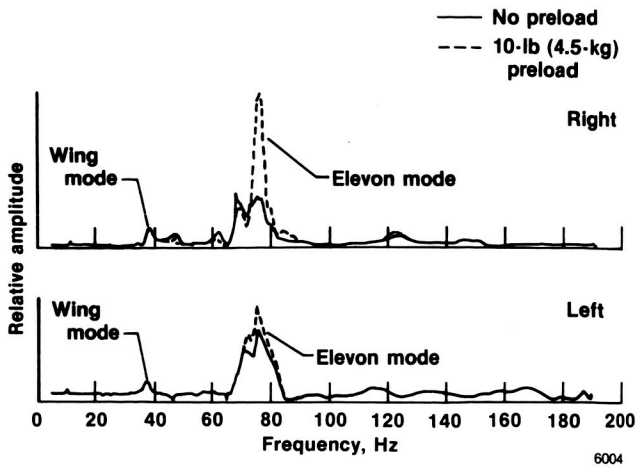

Fig. 12 Effect of suspended mass on modal response (HiMAT vehicle).

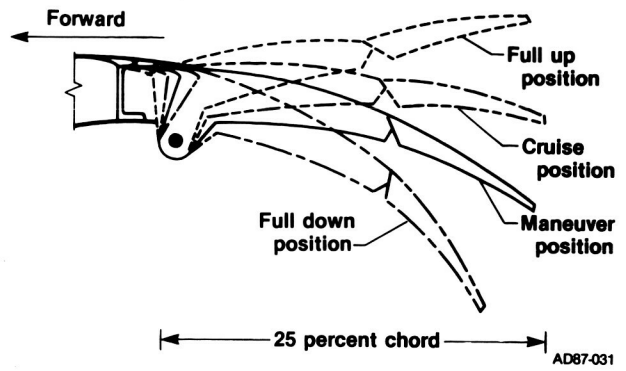

Fig. 13 X-29 discrete variable-camber system.

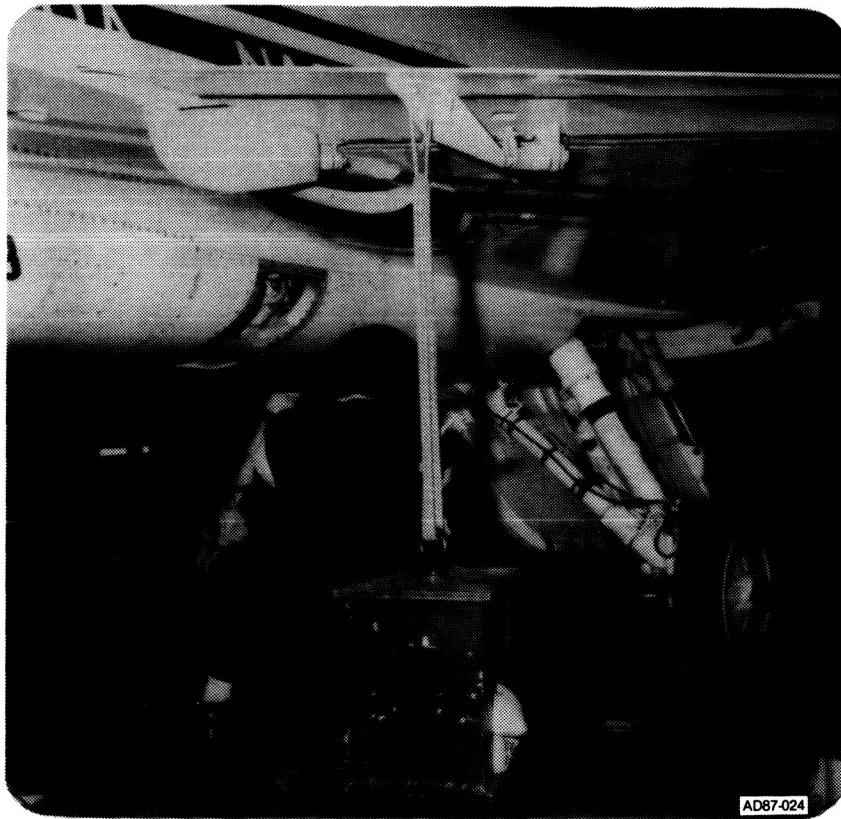

Fig. 14 Inboard flaperon suspended mass.

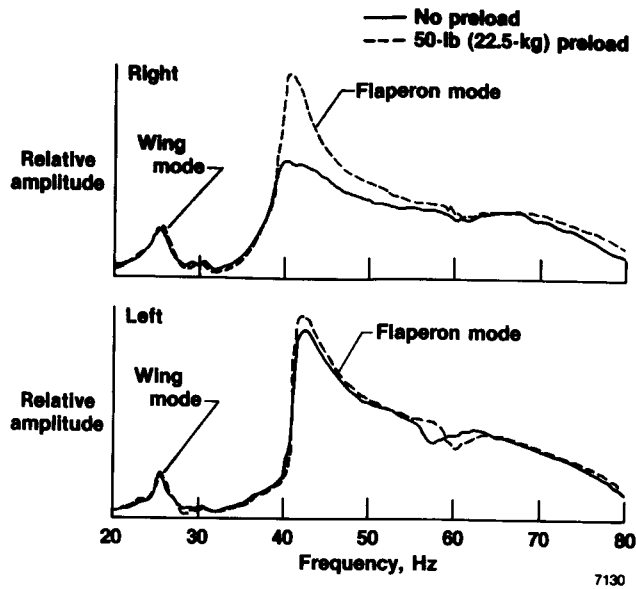

Fig. 15 Effect of suspended mass on modal response (X-29A airplane).

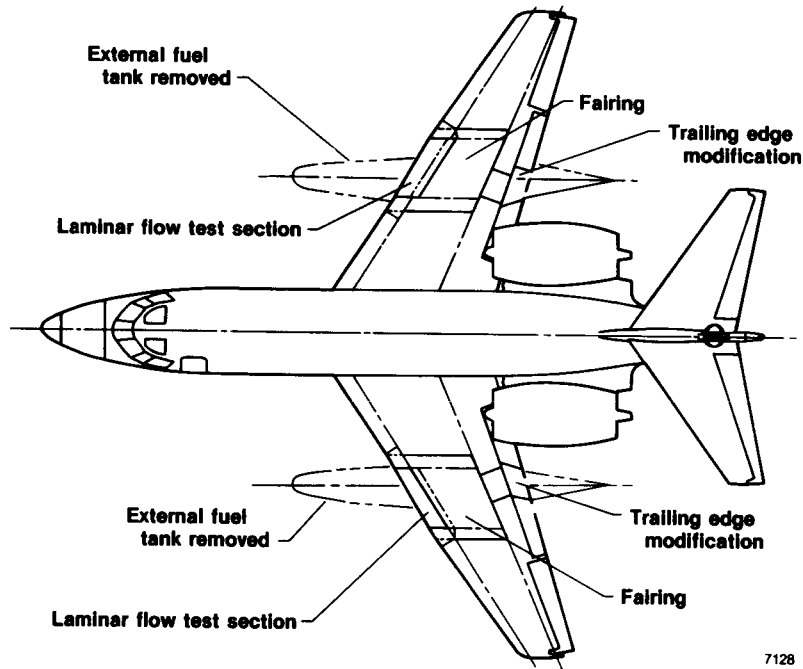
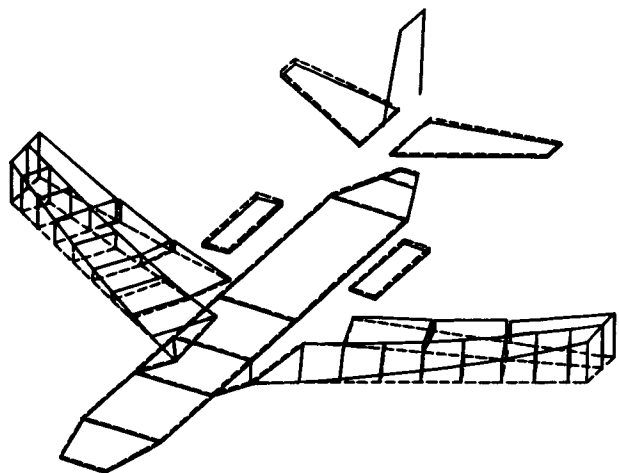
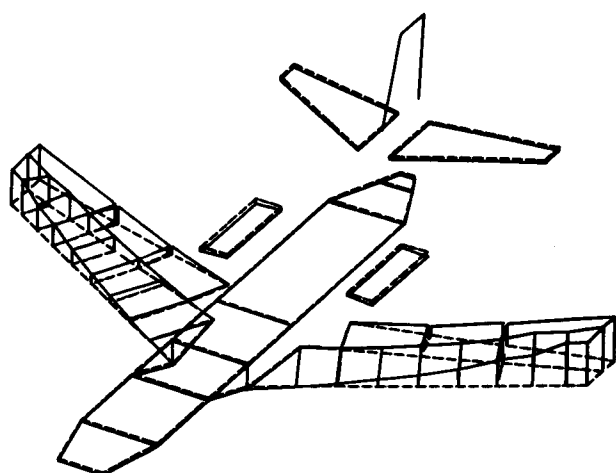

Fig. 16 Laminar flow control JetStar modifications.



4.90 Hz, 0.018-g damping



4.92 Hz, 0.020-g damping

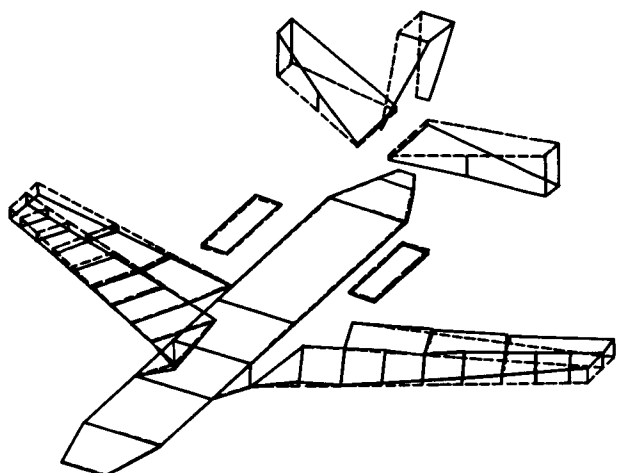

5.05 Hz, 0.028-g damping

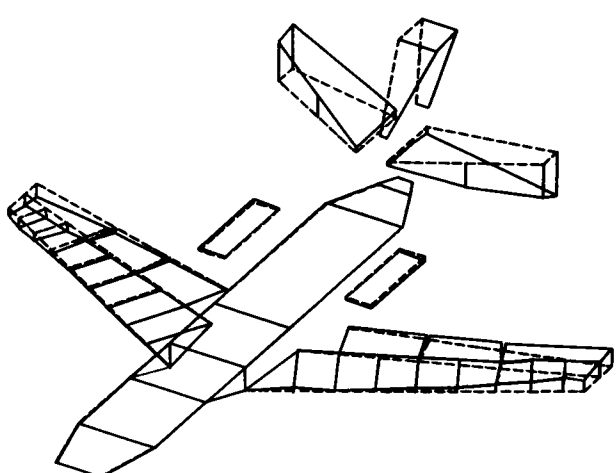

5.20 Hz, 0.014-g damping

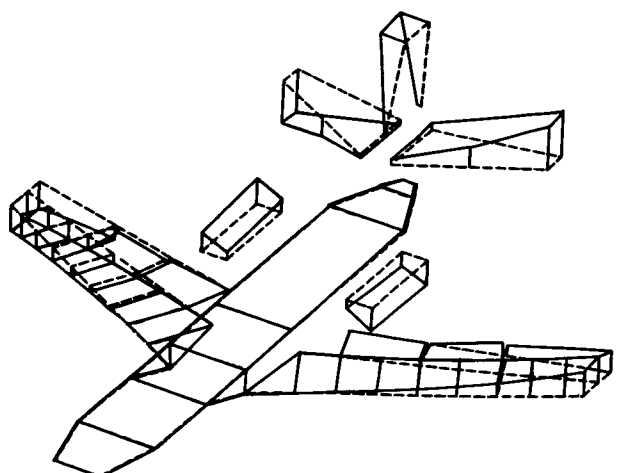

5.75 Hz, 0.026-g damping

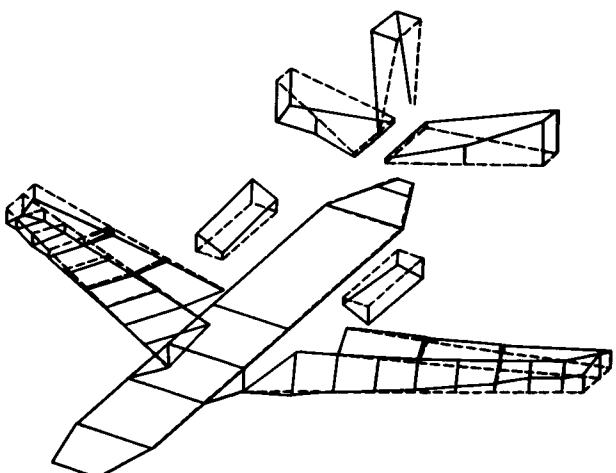

5.97 Hz, 0.014-g damping

6005

*Sine-dwell excitation*

*Single-input random excitation*

Fig. 17 Sine-dwell and single-input random excitation modal data comparison (JetStar airplane).

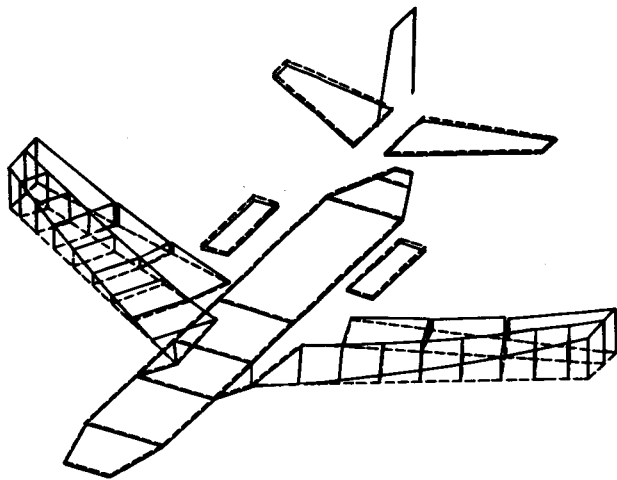

4.90 Hz, 0.018-g damping

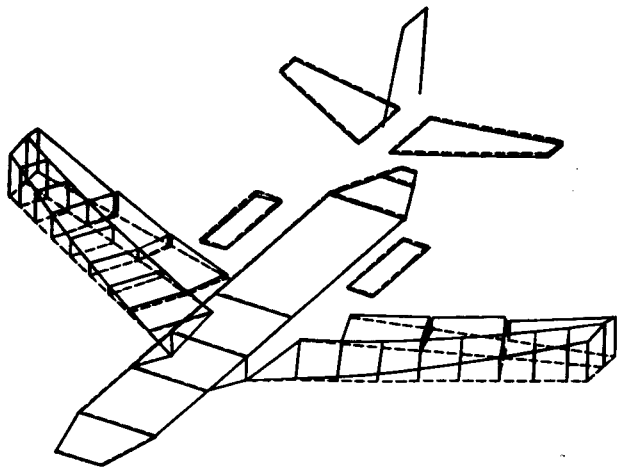

4.92 Hz, 0.011-g damping

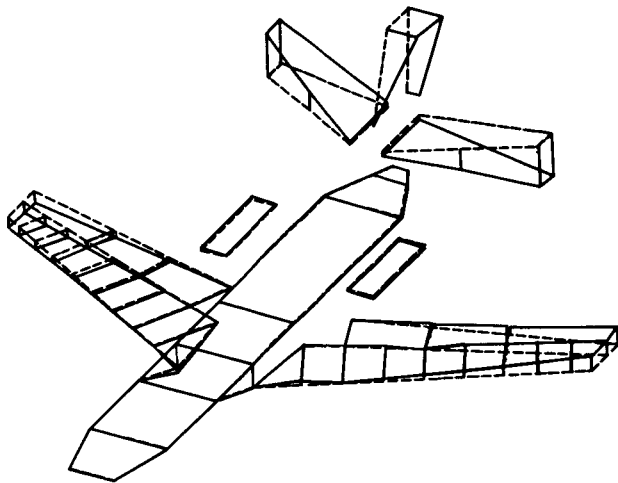

5.05 Hz, 0.026-g damping

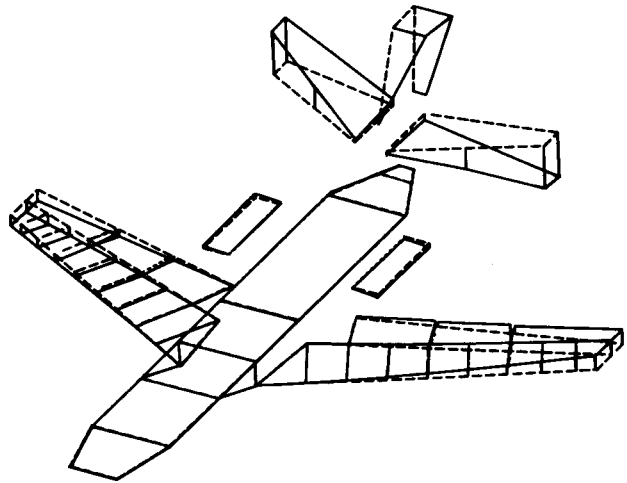

5.13 Hz, 0.017-g damping

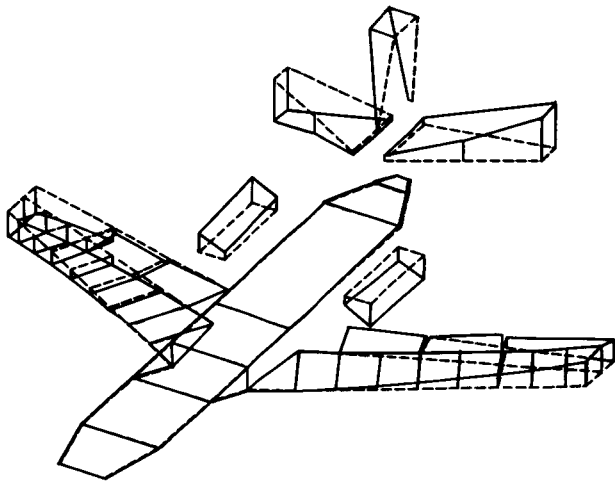

5.75 Hz, 0.026-g damping

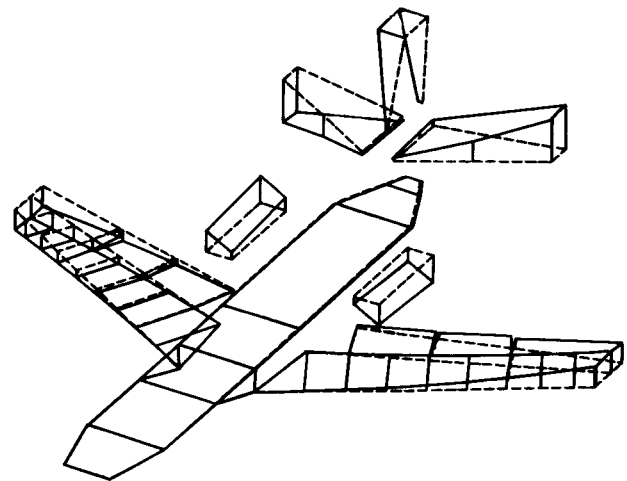

5.87 Hz, 0.017-g damping

8008

*Sine-dwell excitation*

*Multiple-input random excitation*

Fig. 18 Sine-dwell and multiple-input random excitation modal data comparison (JetStar airplane).

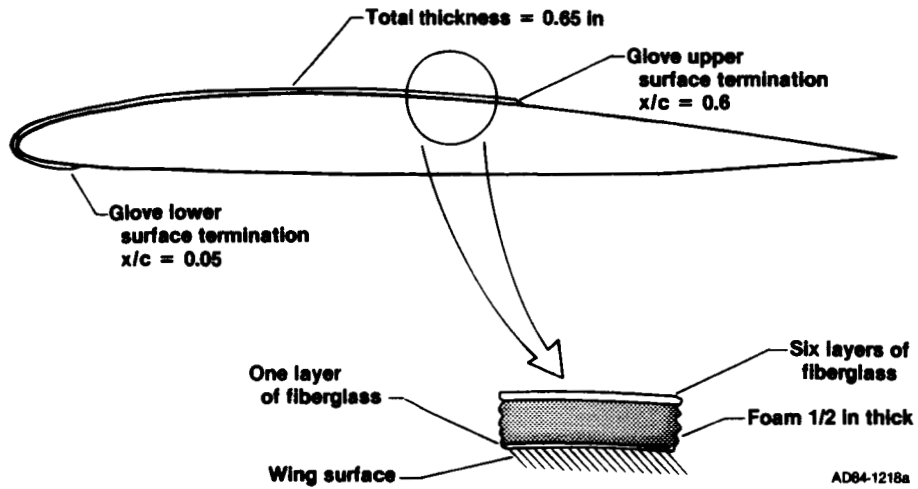

Fig. 19 Typical F-14 wing cross section with glove.

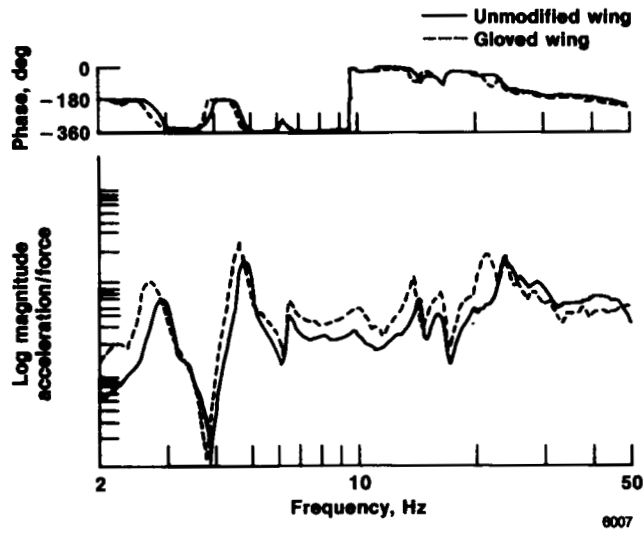
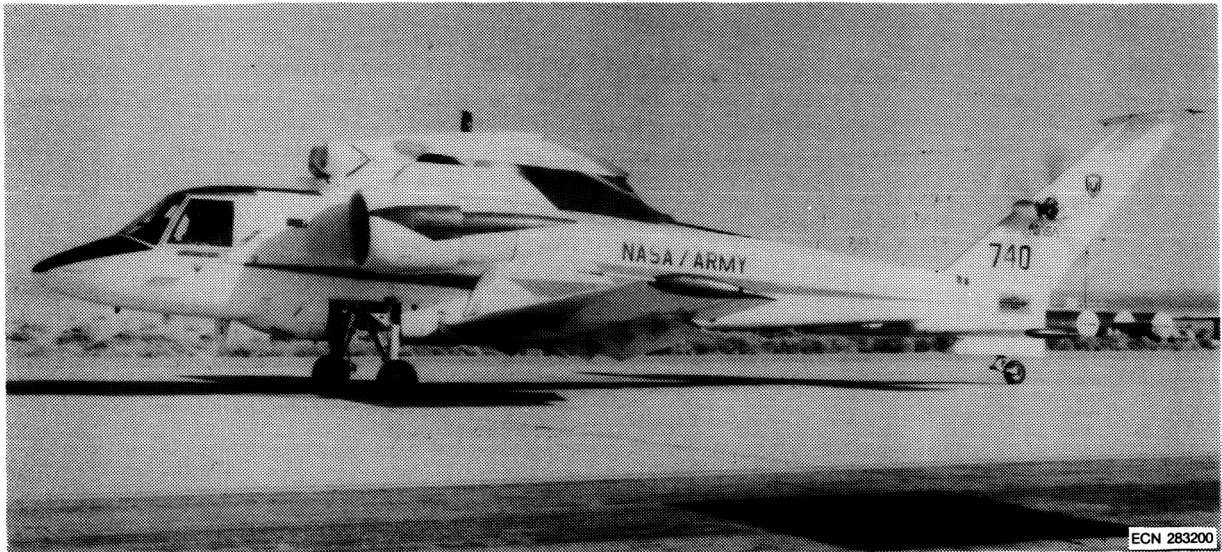
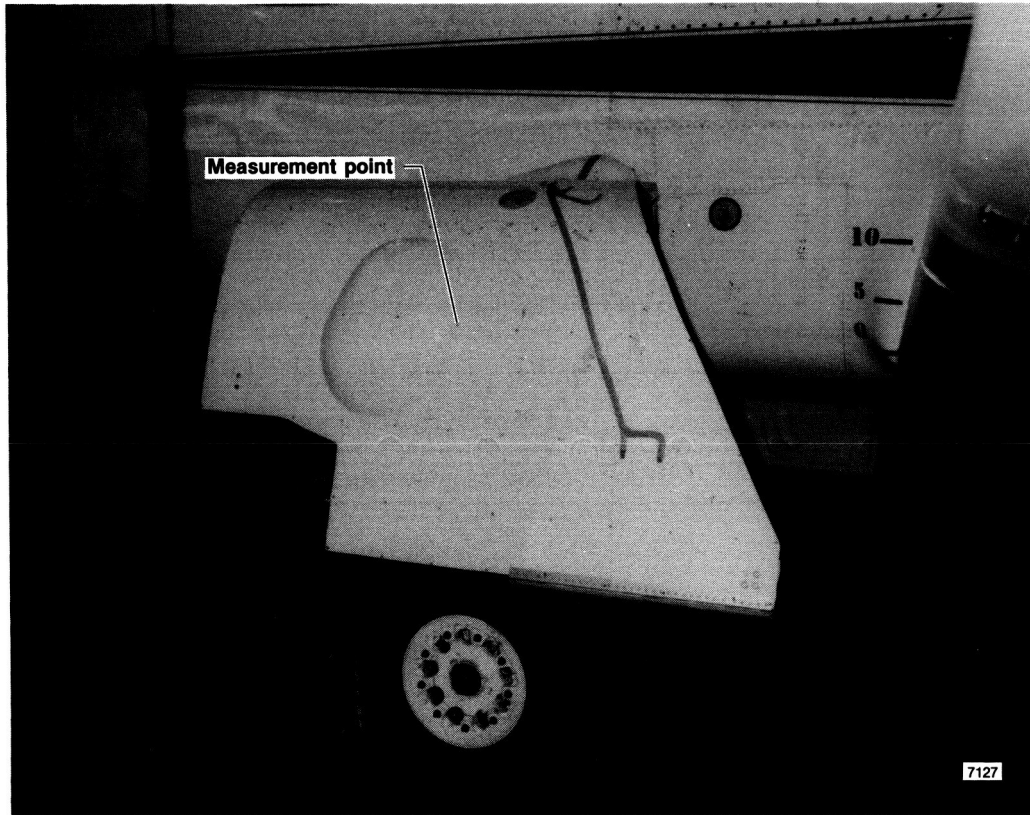

Fig. 20 F-14 wing frequency response function comparison.

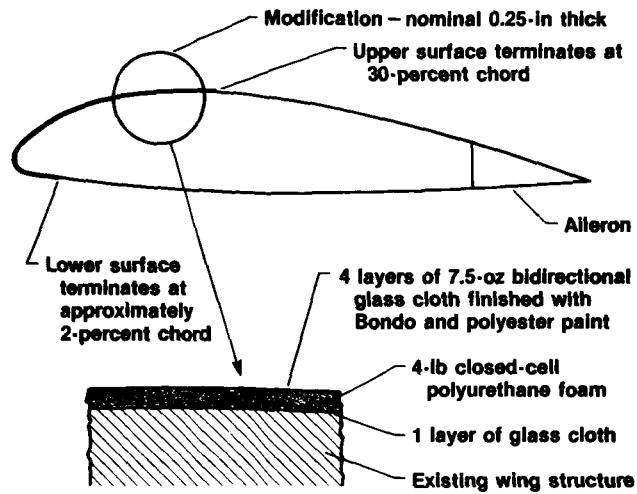

*Fig. 21 RSRA vehicle in the fixed-wing configuration.*



*Fig. 22 RSRA vehicle landing gear door.*

ORIGINAL PAGE IS  
OF POOR QUALITY



7129

Fig. 23 Typical F-15 wing cross section with test section.

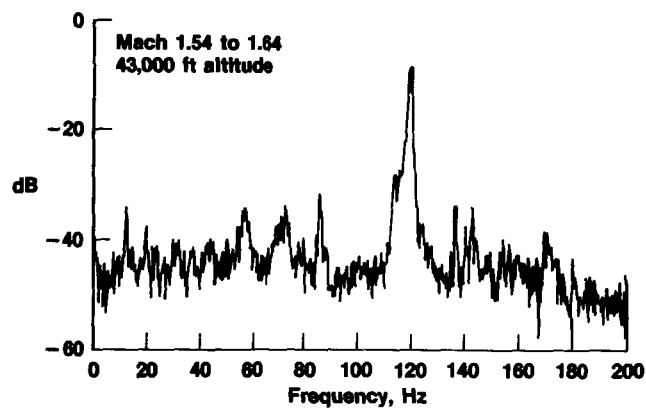

7131

Fig. 24 F-15 right-hand aileron accelerometer power spectral density plot.

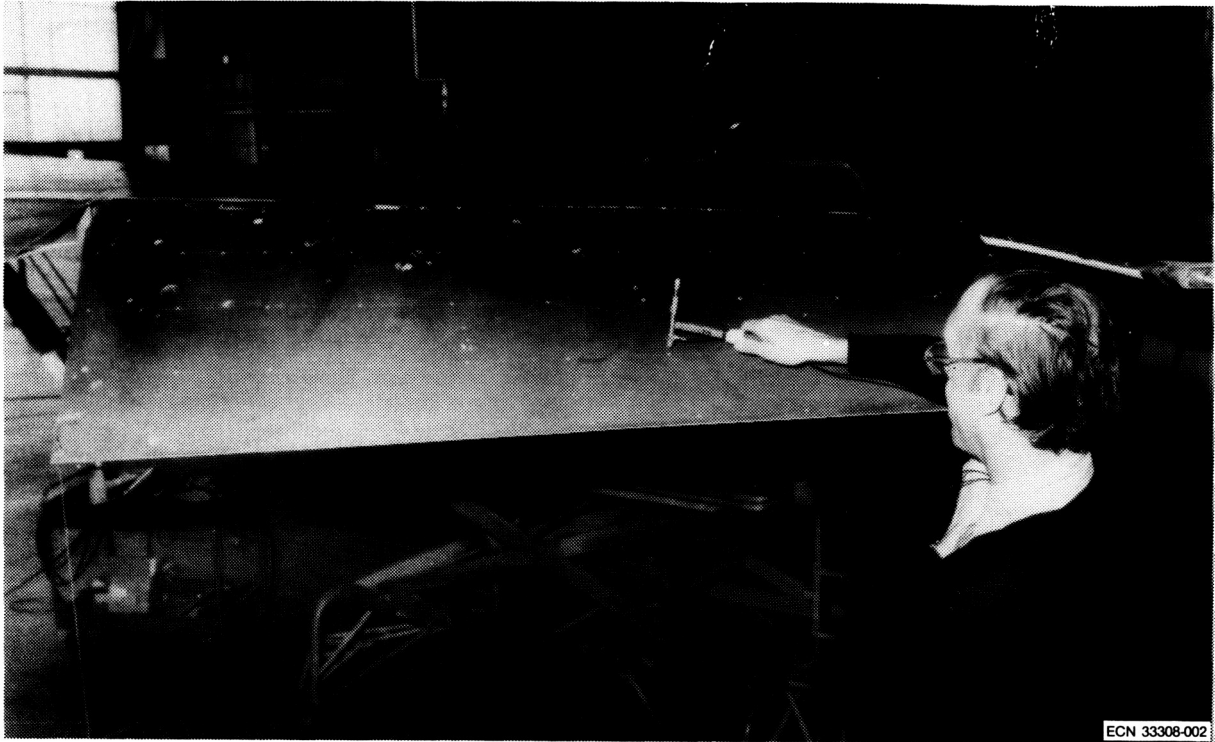

*Fig. 25 F-15 aileron ground vibration test.*

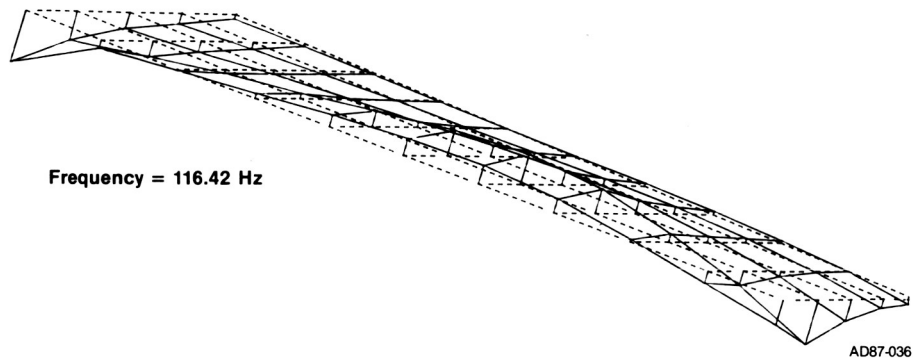

*Fig. 26 F-15 aileron mode shape.*

**ORIGINAL PAGE IS  
OF POOR QUALITY**



1. Report No. NASA TM-88272	2. Government Accession No.	3. Recipient's Catalog No.	
4. Title and Subtitle AIRCRAFT GROUND VIBRATION TESTING AT NASA AMES-DRYDEN FLIGHT RESEARCH FACILITY		5. Report Date July 1987	
		6. Performing Organization Code	
7. Author(s) Michael W. Kehoe		8. Performing Organization Report No. H-1374	
		10. Work Unit No. RTOP 505-63-21	
9. Performing Organization Name and Address NASA Ames Research Center Dryden Flight Research Facility P.O. Box 273 Edwards, CA 93523-5000		11. Contract or Grant No.	
		13. Type of Report and Period Covered Technical Memorandum	
12. Sponsoring Agency Name and Address National Aeronautics and Space Administration Washington, DC 20546		14. Sponsoring Agency Code	
		15. Supplementary Notes Prepared for presentation at the Fifth International Modal Analysis Conference, London, England, Apr. 6-9, 1987.	
16. Abstract  <p>At the NASA Ames Research Center's Dryden Flight Research Facility at Edwards Air Force Base, California, a variety of ground vibration test techniques have been applied to an assortment of new or modified aerospace research vehicles. This paper presents a summary of these techniques and the experience gained from various applications. The role of ground vibration testing in the qualification of new and modified aircraft for flight is discussed. Data are presented for a wide variety of aircraft and component tests, including comparisons of sine-dwell, single-input random, and multiple-input random excitation methods on a JetStar airplane.</p>			
17. Key Words (Suggested by Author(s)) Ground vibration test Modal analysis		18. Distribution Statement Unclassified - Unlimited  Subject category 05	
19. Security Classif. (of this report) Unclassified	20. Security Classif. (of this page) Unclassified	21. No. of Pages 19	22. Price* A02

*\*For sale by the National Technical Information Service, Springfield, Virginia 22161.*