Time-Averaged Aerodynamic Loads on the Vane Sets of the 40- by 80-Foot and 80- by 120-Foot Wind Tunnel Complex

Kiyoshi Aoyagi, Lawrence E. Olson, Randall L. Peterson, Gloria K. Yamauchi, James C. Ross, and Thomas R. Norman

August 1987

(NASA-TM-89413) TIME-AVERAGED AERODYNAMIC
LOADS ON THE VANE SETS OF THE 40- BY 80-FOOT
AND 80- BY 120-FOOT WIND TUNNEL COMPLEX
(NASA) 190 p Avail: NTIS HC AC9/MF A01

N87-27680

Unclas
CSCL 14B G3/09 0094528



National Aeronautics and
Space Administration

Time-Averaged Aerodynamic Loads on the Vane Sets of the 40- by 80-Foot and 80- by 120- Foot Wind Tunnel Complex

Kiyoshi Aoyagi, Lawrence E. Olson, Randall L. Peterson, Gloria K. Yamauchi, James C. Ross,
Thomas R. Norman, Ames Research Center, Moffett Field, California

August 1987

NASA

National Aeronautics and
Space Administration

Ames Research Center
Moffett Field, California 94035

TABLE OF CONTENTS

	Page
LIST OF TABLES.....	v
LIST OF FIGURES.....	vii
SYMBOLS.....	ix
SUMMARY.....	1
INTRODUCTION.....	1
DESCRIPTION OF VANE SETS.....	2
CONDITIONS AND PROPERTIES USED IN LOAD CALCULATIONS.....	5
CALCULATION METHOD.....	7
LOAD CALCULATION INPUTS.....	11
RESULTS.....	16
CONCLUDING REMARKS.....	20
APPENDIX A - THREE-DIMENSIONAL INTEGRATION OF THE DYNAMIC PRESSURE PROFILES ACROSS A VANE SET.....	21
APPENDIX B - JET-EXHAUST AND PROPELLER-WAKE EFFECTS.....	24
APPENDIX C - VANE SET 5 CORRECTION FACTORS TO GLOBAL LOADS.....	28
APPENDIX D - TRUSS LOAD AND PITCHING MOMENT.....	30
APPENDIX E - VANE SET 7 LOAD CALCULATIONS.....	31
REFERENCES.....	47
TABLES.....	49
FIGURES.....	62

PRECEDING PAGE BLANK NOT FILMED

LIST OF TABLES

	Page
Table 1.- Spatially averaged flow condition at vane sets.....	49
Table 2.- Vane set 1 maximum horizontal and vertical velocity profile.....	50
Table 3.- Vane set 2 maximum horizontal and vertical velocity profile.....	51
Table 4.- Vane set 5 maximum horizontal and vertical velocity profile 40 x 80 mode.....	52
Table 5.- Vane set 6 maximum horizontal and vertical velocity profile.....	53
Table 6.- Vane set 8 maximum horizontal and vertical velocity profile.....	54
Table 7.- Vane sets 1 and 2 load cases and inputs.....	55
Table 8.- Vane set 3 load cases and inputs.....	56
Table 9.- Vane set 4 load cases and inputs.....	57
Table 10.- Vane set 5 load cases and inputs.....	58
Table 11.- Vane set 6 load cases and inputs.....	60
Table 12.- Vane set 7 load cases and inputs.....	61
Table 13.- Vane set 8 load cases and inputs.....	61

PRECEDING PAGE BLANK NOT FILMED

LIST OF FIGURES

Page

Vane Set Geometry

Figure 1.- Layout of the 40 × 80 and 80 × 120 circuits showing location of vane sets.....	62
Figure 2.- Details of 90° circular-arc turning vanes at vane sets 1 and 2.....	62
Figure 3.- Vane set 3 layout in 40 × 80 mode.....	63
Figure 4.- Vane set 4 layout and geometry.....	65
Figure 5.- Vane set 5 geometry.....	68
Figure 6.- Fairing located at vane set 5 corner.....	69
Figure 7.- Vane set 6 geometry.....	70
Figure 8.- Vane set 7 layout.....	71
Figure 9.- Details of 90° circular-arc turning vanes at vane set 8.....	72

Inputs for Vane Set Loads

Figure 10.- Dynamic pressure surveys in front of vane set 1: 1/50-scale 40 × 80 model, $q_{50ts} = 59.76 \text{ lb/ft}^2$, $m = 8.6\%$	73
Figure 11.- Dynamic pressure surveys in front of vane set 2: 1/50-scale 40 × 80 model, $q_{50ts} = 59.76 \text{ lb/ft}^2$, $m = 8.6\%$	74
Figure 12.- Variation of loss coefficient η and angle of outflow with angle of onset for vane sets 1 and 2.....	75
Figure 13.- Chordwise pressure distribution of vane sets 1 and 2: Lewis Research Center design vane, 1/10-scale tester data.....	76
Figure 14.- Variation of c_m about $1/4 c$ with angle of onset; 1/10-scale tester data.....	77
Figure 15.- Local load distribution on vane set 1 owing to wake vortex.....	77
Figure 16.- Maximum vertical dynamic pressure profile at vane set 1: $v_{fst} = 300 \text{ knots}$, $q_{fst} = 262 \text{ lb/ft}^2$	78

Figure 17.- Two-dimensional moment characteristic (ref. 8).....	79
Figure 18.- Local load distribution on vane set 4 owing to vortex wake: model lift = 100,000 lb, $q_{fst5} = 33.6 \text{ lb/ft}^2$	79
Figure 19.- Variation of estimated jet dynamic pressure and temperature with vane set 4 span: $x = 205 \text{ ft}$ from 80×120 test section centerline, vane span = 69.3 ft	81
Figure 20.- Dynamic pressure surveys in front of vane set 5: 40×80 mode, $1/50$ -scale 40×80 model, $q_{50ts} = 59.69 \text{ lb/ft}^2$, $m_{50} = 8.6\%$	82
Figure 21.- Variation of loss coefficient and angle of outflow with angle of onset: vane set 5, Lewis Research Center fixed-vane design 3, $1/10$ -scale tester data.....	83
Figure 22.- Chordwise surface-pressure distribution of vane set 5: $1/10$ -scale tester data.....	84
Figure 23.- Variation of c_m with onset angle: vane set 5, Lewis Research Center fixed-vane design 3, $1/10$ -scale tester data.....	88
Figure 24.- Local load distribution on vane set 5 owing to a vortex wake: model lift 100,000 lb.....	88
Figure 25.- Variation of estimated jet dynamic pressure and temperature with vane set 5 span; $x = 303 \text{ ft}$ from 80×120 test centerline, vane span 75.4 ft	89
Figure 26.- Estimated maximum dynamic pressure profiles of jet and propeller wakes at vane set 5: $x = 304 \text{ ft}$	91
Figure 27.- Dynamic pressure surveys in front of vane set 6: $1/50$ -scale 40×80 model, $q_{50ts} = 59.76 \text{ lb/ft}^2$, $m_{50} = 8.6\%$	92
Figure 28.- Variation of loss coefficient and angle of outflow with angle of onset; vane set 6 with trailing-edge flap chord of 6 ft , $1/10$ -scale tester data.....	93
Figure 29.- Chordwise pressure distribution of vane set 6 with trailing-edge flap of 6 ft ; $1/10$ -scale tester data.....	94
Figure 30.- Variation of vane set 6 c_m about $1/4$ vane chord; $1/10$ -scale tester data.....	96
Figure 31.- Variation of trailing-edge flap normal force and hinge moment coefficients of vane set 6; $1/10$ -scale tester data.....	97

Figure 32.- Variation of total and static pressures in front of vane set 7 with 80 x 120 test section dynamic pressures; 80- by 120-Foot Wind Tunnel IST of 1982.....	99
Figure 33.- 1/50-scale 80 x 120 model laser survey of vane set 7 exit velocity and direction with exit ramp.....	100
Figure 34.- Dynamic pressure surveys in front of vane set 8: 1/50-scale 40 x 80 model, $q_{50ts} = 59.25 \text{ lb/ft}^2$, $m = 8.6\%$	101
Figure 35.- Variation of pressure loss coefficient and ϵ_2 with ϵ_1 for vane set 8; 1/10-scale tester data.....	101
Figure 36.- Chordwise pressure distribution of vane set 8: 1/10-scale tester data.....	102
Figure 37.- Variation of vane set 8 pitching moment coefficient with angle of onset.....	104

Result

Figure 38.- Global design and operating loads of vane sets 1 and 2.....	105
Figure 39.- Variation of estimated maximum local design load with vane span for vane set 1; $YH = -0.232$	109
Figure 40.- Comparison of maximum lift and drag with vortex and jet exhaust wake effects at vane set 1.....	114
Figure 41.- Variation of estimated maximum local load with vane 3I span.....	115
Figure 42.- Spanwise vane loads of vane set 4; 80 x 120 mode.....	121
Figure 43.- Effect of vortex, jet, and propeller wakes on spanwise vane loads vane set 4: $\epsilon_1 = 0^\circ$, $\epsilon_2 = 0^\circ$, wake center at vane midspan.....	139
Figure 44.- Vane set 4 local loads and vane 4C space truss loads for 40 x 80 mode.....	140
Figure 45.- Global design and operating loads for vane set 5.....	141
Figure 46.- Variation of local load with vane span for vane set 5; 80 x 120 mode.....	150
Figure 47.- Variation of local load with vane span for vane set 5; 40 x 80 mode.....	158

Figure 48.- Global design and operating loads for vane set 6.....160

Figure 49.- Variation of local design load with vane span for vane set 6;
40 x 80 mode.....163

Figure 50.- Global design and local loads for vane set 7.....168

Figure 51.- Global design and operating loads for vane set 8; 40 x 80 mode.....169

Figure 52.- Variation of local design load with vane span for vane set 8;
40 x 80 mode.....172

Figure 53.- Tabulated local design loads with vane span for vane set 8;
40 x 80 mode.....174

SYMBOLS

A	vane frontal area perpendicular to the vane set stagger line, m^2 (ft^2)
A_j	jet exhaust nozzle area, m^2 (ft^2)
A_{TC}	tunnel cross-sectional area perpendicular to the tunnel circuit centerline, m^2 (ft^2)
A_{sp}	vane set total splitter plate area, m^2 (ft^2)
b	vane span from floor to ceiling, m (ft)
c	vane chord, m (ft)
c_f	vane flap chord, m (ft)
$(c_d)_{sp}$	splitter plate drag coefficient, splitter drag/ qc
CONV	conversion constant
c_m	pitching moment coefficient about $0.25c$, pitching moment/ qc^2
c_n	normal force coefficient, normal force/ qc
c_p	vane surface pressure coefficient, $(P - P_{AMB})/q$ or specific heat of air at constant pressure, J/kg K° (Btu/lb R°)
c_v	specific heat of air at constant volume, J/kg K° (Btu/lb R°)
D	summation of inviscid and viscous drag per vane span, N/m (lb/ft)
DDT	total drag translated from vane stagger line to tunnel circuit centerline per vane span, N/m (lb/ft)
D_i	inviscid drag per vane span, N/m (lb/ft)
D_j	jet nozzle exit diameter, m (ft)
D_o	propeller diameter, m (ft)
D_p	propeller flow exit diameter, m (ft)
D_T	total drag per vane span, N/m (lb/ft)
D_{truss}	drag due to vane truss per vane span, N/m (lb/ft)

D_v	viscous drag per vane span, N/m (lb/ft)
D_{vor}	drag due to vortex wake effect per vane span, N/m (lb/ft)
dy	incremental difference in horizontal distance, m (ft)
dz	incremental difference in vertical distance, m (ft)
F_1	correction factor to global lift to account for dynamic pressure profile and splay angle change across vane set 5 (see appendix C)
F_2	correction factor to inviscid global drag to account for dynamic pressure profile and splay angle across vane set 5 (see appendix C)
F_3	correction factor to account for nonuniform dynamic pressure profile across a vane set (see appendix A)
F_J	gross jet engine thrust, N (lb)
F_p	propeller thrust, N (lb)
F_θ	tangential-force coefficient when angle of incidence is θ and angle of exit is ϕ .
g	acceleration of gravity, 9.8 m/sec ² (32.2 ft/sec ²)
K	pressure-drop coefficient when $\theta = 0$
K_1	empirical constant (see appendix B)
K_2	empirical constant (see appendix B)
L	lift per vane span, N/m (lb/ft)
L_i	inviscid lift per vane span, N/m (lb/ft)
LLT	total lift translated perpendicular from vane stagger line to direction perpendicular to tunnel circuit centerline per vane span, N/m (lb/ft)
L_{vor}	lift due to vortex wake effect per vane span, N/m (lb/ft)
M	Mach number or pitching moment about vane quarter chord per vane span, mN/m (ft·lb/ft)
M_{truss}	pitching moment due to vane truss per vane span about vane pivot, N·m/m (ft·lb/ft)

M_{vor}	pitching moment due to vortex wake effect about vane quarter chord per vane span, $m \cdot N/m$ (ft·lb/ft)
m_{fs}	full-scale facility air-exchange rate, percent of test section flow rate
m_j	jet engine weight rate of flow, N/sec (lb/sec)
m_{50}	1/50-scale facility air-exchange rate, percent of test section flow rate
P	pressure or vane set pitch, N/m^2 (lb/ft ²) or m (ft)
P_{AMB}	ambient pressure, N/m^2 (lb/ft ²)
P_o	stagnation pressure, N/m^2 (lb/ft ²)
q	full-scale facility dynamic pressure in front of a vane set, N/m^2 (lb/ft ²)
q_{AVG}	full-scale facility dynamic pressure in front of a vane set based on uniform velocity profile with onset flow angle, N/m^2 (lb/ft ²)
q_o	full-scale facility dynamic pressure in front of a vane set based on uniform velocity profile with zero onset flow angle, N/m^2 (lb/ft ²)
q_{fst}	full-scale facility test section dynamic pressure, N/m^2 (lb/ft ²)
q_h	1/50-scale facility local dynamic pressure along a horizontal line or centerline, N/m^2 (lb/ft ²)
q_H	full-scale facility local dynamic pressure in the horizontal direction, N/m^2 (lb/ft ²)
q_{jet}	jet wake dynamic pressure, N/m^2 (lb/ft ²)
q_m	full-scale facility mean dynamic pressure, N/m^2 (lb/ft ²)
q_v	1/50-scale facility local dynamic pressure along a vertical line or centerline, N/m^2 (lb/ft ²)
q_V	full-scale facility local dynamic pressure in the vertical direction, N/m^2 (lb/ft ²)
q_{50ts}	1/50-scale facility test section dynamic pressure, N/m^2 (lb/ft ²)
R	gas constant for air, 8314.34 J/kg·mole, K° (53.3 ft·lb/lb, R°)
r	radius of jet or propeller wake, m (ft)
sa	angle between vane set stagger line and tunnel circuit centerline, deg

t/c	vane-thickness/vane-chord
T	static temperature, K° (R°)
T ₀	stagnation temperature, K° (R°)
U	velocity, m/sec (ft/sec)
u	local velocity, m/sec (ft/sec)
V ₁	flow velocity, V ₂ /cos β, m/sec (ft/sec)
V _{AVG}	uniform flow velocity in front of the vane set parallel to the tunnel centerline that results in the same mass flow rate as is present in the test section, m/sec (ft/sec)
V _H	flow velocity in the horizontal direction satisfying continuity, m/sec (ft/sec)
V _{max}	maximum local flow velocity, m/sec (ft/sec)
V _Z	velocity perpendicular to the vane set stagger line, V cos β ₁ , m/sec (ft/sec)
V _{Zℓ}	local velocity perpendicular to the vane set stagger line, V cos β ₁ , m/sec (ft/sec)
W	width of vane set, m (ft)
W _{fts}	full-scale facility test section weight rate of flow, N/sec (lb/sec)
x	1/50-scale test section dynamic pressure, cm of H ₂ O (in. of H ₂ O) or longitudinal distance downstream from jet nozzle exit, m (ft)
x _{cp}	center of pressure distance from vane leading edge, m (ft)
x/c	longitudinal ordinate, percent of vane chord
Y	1/50-scale facility horizontal survey of dynamic pressure in front of a vane set, cm N ⁻¹ m ⁻² (in. lb ⁻¹ ft ⁻²)
YFS	vane span, m (ft)
YH	vane span from vane midspan, percent of vane span
y	lateral distance downstream from jet nozzle exit, m (ft)

z	1/50-scale facility vertical survey of dynamic pressure in front of a vane set, $\text{cm N}^{-1} \text{m}^{-2}$ (in. $\text{lb}^{-1} \text{ft}^{-2}$)
z/c	vertical ordinate, percent of vane chord
α	limiting value of ϕ/θ as θ approached zero
β_1	angle between the onset flow velocity and the velocity perpendicular to the vane set stagger line, deg
β_2	angle between the outflow velocity and the velocity perpendicular to the vane set stagger line, deg
β'_2	angle between the outflow velocity with the vane splay angle added, and the velocity perpendicular to the vane set stagger line, deg
γ	ratio of specific heat, c_p/q_v
δ_f	vane set flap deflection, deg
ΔP	pressure difference across vane set, N/m^2 (lb/ft^2)
$(\Delta P/q)_s$	vane surface roughness loss coefficient
ϵ_1	angle of onset with respect to the tunnel circuit centerline, deg
ϵ_2	angle of outflow with respect to the tunnel circuit centerline, deg
η	total pressure-loss coefficient
μ	viscosity, $\text{N}\cdot\text{sec}/\text{m}^2$ ($\text{lb}\cdot\text{sec}/\text{ft}^2$) or ratio of free-stream velocity to jet centerline velocity
ρ	mass density, $\text{kg}\cdot\text{sec}^2/\text{m}^4$ ($\text{lb}\cdot\text{sec}^2/\text{ft}^4$)
σ	vane splay angle, deg
σ_T	spreading rate of jet or propeller wake temperature (dimensionless)
σ_U	spreading rate of jet or propeller wake velocity (dimensionless)
ϕ	angle of flow exit measured from normal to screen, deg

Subscripts:

1	condition upstream of vane set
2	condition downstream of vane set or outside the jet or propeller wake

50 1/50-scale model of National Full-Scale Aerodynamic Complex (NFAC)

cv corner vane

C centerline

D propeller diameter

f flap

fs full scale

h 1/50-scale value in the horizontal direction

H horizontal direction

mv vane at middle portion of vane set

J jet

o stagnation

p propeller exit

r distance from the jet or propeller wake centerline to the x,y location of interest

s static

T total

ts test section

v 1/50-scale value in the vertical direction

V vertical direction

vor vortex wake effect

SUMMARY

Time-averaged aerodynamic loads are estimated for each of the vane sets in the National Full-Scale Aerodynamic Complex (NFAC). The methods used to compute global and local loads are presented. Experimental inputs used to calculate these loads are based primarily on data obtained from tests in the 1/10-Scale Vane-Set Test Facility and from tests conducted in the NFAC 1/50-Scale Facility. For those vane sets located directly downstream of either the 40- by 80-ft test section or the 80- by 120-ft test section, aerodynamic loads caused by the impingement of model-generated wake vortices and model-generated jet and propeller wakes are also estimated.

INTRODUCTION

The National Full-Scale Aerodynamic Complex (NFAC) at Ames Research Center is being modified to improve the aerodynamic characteristics of the facility (refs. 1,2). This facility is composed of two wind-tunnel circuits, a closed-loop circuit with a 40- by 80-ft (12- by 24-m) test section and an open-loop (non-return) circuit with an 80- by 120-ft (24- by 36-m) test section with airspeed capabilities of 300 knots (154 m/sec) and 100 knots (51 m/sec), respectively. Either a 40 x 80 mode or an 80 x 120 mode can be operated, using the same fan drives by means of a flow-diverter system.³

The need for a modification program to improve the aerodynamic characteristics of the facility became apparent during the Integrated System Test (IST) of 1982, which was conducted to evaluate the aerodynamic and structural performances of the facility. As part of the modification program, aerodynamic loads have been determined for each of the turning vane sets. The 80 x 120 tunnel inlet vane set loads will be presented in a separate report. Both time-averaged and dynamic loads were calculated. The subject of this report is the determination of the time-averaged loads. Dynamic loads are discussed in a separate report (refs. 4,5).

Time-averaged aerodynamic loads were determined for design loads and for operating loads. There is only a very low probability that the design loads will be exceeded during the lifetime of the facility. The operating loads are the expected loads when the wind tunnel is operated at maximum flow speed.

Time-averaged loads were calculated for global and local loads. The global design loads are the maximum probable loads that must be taken out by external structures supporting a vane set. The global operating loads are expected loads

during maximum-speed operation and are to be used for the forthcoming NFAC Integrated Systems Test as maximum speed limits. Local design loads are the maximum spanwise loads of a vane (floor to ceiling) and are used to evaluate the vane structural performance of the vane. Local operating loads are expected spanwise loads of a vane during maximum tunnel flow speed and are to be used for the forthcoming IST of the NFAC as maximum speed limits. The additional loads owing to vortex, jet exhaust, or propeller wakes from a model located in the test section were also evaluated for affected vane sets.

This report presents the calculation methods used to determine the aforementioned loads, the inputs used in these calculations, and the results.

DESCRIPTION OF VANE SETS

Each vane set of the $40 \times 80/80 \times 120$ tunnel is designated by a number (fig. 1). All of the vane sets except set 8 are new designs and are part of the wind-tunnel modification work. Vane sets 3, 4, 5, and 6 will be located in the wind-tunnel flow field during both 40×80 and 80×120 modes of operation.

Vane Sets 1 and 2

Vane set 1 is located at the northeast corner of the 40×80 tunnel circuit, downstream of the primary diffuser section, and vane set 2 is located at the northwest corner of the circuit in the constant-duct-area section. The design and geometry of both vane sets are the same. The vane contour and spacing, which were designed by the NASA Lewis Research Center, are shown in figure 2. The vane has a chord (leading edge to trailing edge) of 6.0 ft, a pitch (trailing edge to trailing edge) of 3.0 ft, and a span (floor to ceiling) of 68.6 ft. There are 50 vanes in all. Five full-chord horizontal splitter plates extend across the vane set and are evenly spaced at each 11-ft elevation. An air-exchange inlet is located at the inner wall of the circuit between these two vane sets.

Vane Set 3

Vane set 3 is located close to the northwest corner of the 40×80 circuit. It consists of eight large, rectangular, flat-surface panels with faired leading and trailing edges. Figure 3 shows the vane set layout, geometry and dimensions. Each vane can be pivoted, so that it can be opened parallel to the 40×80 circuit or can be joined together to form a wall for the 80×120 circuit. Except for vane 3N (fig. 3(a)), a truss frame composed of a 2- by 8-in. rectangular tube (fig. 3(b)) extending from the floor to the ceiling is attached along the vane pivot line. Except at intersections of the framework, the framework has a streamline fairing at the leading and trailing edges. When the vane set forms a wall, these trusses

extend inside the 80 x 120 circuit and, therefore, are in the airstream in both modes of operation.

Vane Set 4

Vane set 4 consists of six large, rectangular, flat-surface panels with faired leading and trailing edges. Figure 4 shows the vane set layout, geometry, and dimensions. Each vane panel can be pivoted so that it is parallel to the 80 x 120 circuit centerline or joined together to form a wall for the 40 x 80 circuit. A truss frame extending from the floor to the ceiling is attached along the pivot line, except for vane 4F (fig. 4). When the vane set forms a wall, these trusses extend inside the 40 x 80 circuit. The truss dimensions are approximately equal to those of vane set 3. In addition to this single spanwise truss, vane 4C has three chordwise space trusses located along the span (fig. 4(c)). These trusses were installed to minimize the deflection of this vane that was observed during the 40 x 80 IST in 1982.

Vane Set 5

Vane set 5 is located at the northwest section of the tunnel circuit downstream of vane set 3 and upstream of the drive fans. This vane set is designed to turn the flow toward the drive fans during the 80 x 120 mode and to provide virtually no turning during the 40 x 80 mode. The 36 vanes are fixed, with a chord of 6.7 ft, a pitch of 3.4 ft, and an average span of 75.4 ft. The vane shape was designed by the NASA Lewis Research Center and is shown in figure 5. Two horizontal splitter plates, which extend across the vane set, are spaced 22.8 ft apart. Since the vane set is located in the diffuser section of the tunnel, each vane is splayed as shown below:

Splay angle, deg	Number of vanes	Direction	Spanwise extent from west wall, % of vane set width
-3	6	West wall	0 to 0.158
-2	5		0.185 to 0.292
-1	5		0.318 to 0.425
0	5	Center	0.452 to 0.559
1	5		0.585 to 0.692
2	5		0.719 to 0.826
3	5	East wall	0.852 to 1.00

A streamline fairing is located at the west corner of the vane set to improve the flow-turning between the west wall and the adjacent vanes during the 80 x 120 mode (fig. 6).

Vane Set 6

Vane set 6 is located at the southwest corner of the 40 x 80 tunnel. It consists of 57 acoustically treated vanes with a chord of 17.21 ft and a pitch of 4.24 ft (fig. 7). A trailing-edge flap of 6 ft chord, which is hinged at the 0.64c station, is deflected 80° relative to the chord line to provide the required flow-turning during the 40 x 80 mode; it is undeflected during the 80 x 120 mode. Because of the clearance problem at vane set 7, the last four vanes at the southwest corner do not have flaps. Horizontal splitter bars (two bars at each elevation) extend across the vane set width at 11 elevations and are evenly spaced 11 ft apart.

An acoustic barrier wall, which extends from the floor to the ceiling, is located between vane sets 6 and 7, approximately 25 ft from the southwest corner of the tunnel circuit (fig. 1). Since the southwest corner of vane set 7 is opened permanently, this wall is designed to attenuate the noise radiating forward of the 40 x 80 test section during powered model operation.

Vane Set 7

Vane set 7 is located at the southwest wall of the 40 x 80 tunnel. During the 80 x 120 mode, this set is opened to exhaust the airflow upward to the atmosphere. Except for the southwest corner during the 40 x 80 mode, it is closed to form a wall. At the southwest corner, all of the vane panels are deflected permanently according to the deflection schedule shown in figure 8. This provides an air-exchange exhaust opening during 40 x 80 operation (ref. 6). The entire vane set consists of 12 horizontal rows and 9 vertical columns of flat rectangular panels with an average chord and pitch of 10.5 ft. The panel dimensions are shown in figure 8. These panels are supported by a structural framework that consists of eight exposed vertical columns 1 ft wide and, at each 11-ft elevation, by horizontal members 1 ft wide that span between the columns. A 74% porosity bird screen is attached from the outside to this framework. The screen has a 5- by 5-in. angle diagonal bracing in each of the roughly 10- by 20-ft bays. The solid blockage owing to the structural members and panels is approximately 16% of the open area in front of the vane set. For the 80 x 120 operation, each horizontal row of panels is deflected to turn the air upward, starting at 25° with respect to the horizontal plane at the bottom and varying in 2° increment to 45° at the top. A 45° ramp at ground level is located outside of the vane set to deflect the exhaust upward at ground level (ref. 7).

Vane Set 8

Vane set 8 is located at the southeast corner of the 40 x 80 circuit. This set has 159 vanes with a chord of 3 ft and a pitch of 1.5 ft, and a span of 132.5 ft. The vane has a circular-arc profile as shown in figure 9. Eleven full-chord rows of horizontal splitter plates are evenly spaced at approximately 14.4 ft in elevation. Each splitter extends the full span width of the vane set.

CONDITIONS AND PROPERTIES USED IN LOAD CALCULATIONS

Global design and operating loads and local design loads were calculated for the vane sets located in the 40 x 80/80 x 120 wind tunnel as shown in figure 1. The global design loads are used to determine the aerodynamic loads on the structure supporting a vane set. The local design loads primarily describe how the aerodynamic loads are distributed along the span of individual vanes. These loads are used to determine aerodynamic loads on aerodynamic surfaces acting on the substructure supporting these surfaces, and the attachment of the individual vanes to the supporting superstructure. The global operating loads are expected loads during maximum speed operation and are to be used as limits for the forthcoming Integrated System Tests (IST).

The loads were calculated assuming maximum test-section speeds of 300 knots and 100 knots, which correspond to dynamic pressures of 262.44 lb/ft² and 33.18 lb/ft², respectively, for the 40 x 80 and the 80 x 120 circuits. Loads were calculated for the vane-set flow conditions shown in table 1. Additional loads owing to the effect of jet exhaust or vortex wake were calculated for the appropriate vane sets. It was assumed that jet exhaust loads and vortex loads would not occur simultaneously.

Vane-set loads can be related to flow onset angle, outflow angle, viscous drag coefficient, pitching moment coefficient, dynamic pressure, splitter-plate drag coefficient, and vane-surface roughness coefficient.

Onset Angle

For the vane set located in or at the end of a diffuser section of the tunnel circuit the onset angle for the design load was assumed to be bounded by the angle of the two sidewalls measured relative to the circuit centerline. For vane sets 2 and 8, which are located in the constant-area duct of the tunnel circuit, the onset angle was determined by the angle of outflow from vane sets 1 and 6, respectively.

Outflow Angle

Except for vane set 6, an outflow angle was determined for a selected onset angle using the 1/10-Scale Vane-Set Facility data (ref. 1). A Reynolds-number-effect correction of -1° (overturning) was added to this outflow angle. This Reynolds number correction was assumed to be independent of onset angle. An angle of ±2° was then added to this outflow angle with the Reynolds-number correction. For 40 x 80 operation an outflow angle of ±3° was selected for vane set 6 to account for possible swirling flow effects of the wind-tunnel-circuit drive fans located upstream of the vane set.

Viscous Drag Coefficient

Individual vane coefficients were determined from the 1/10-Scale Vane-Set Test Facility data by integrating the total-pressure profiles over several vane pitches for a selected onset angle, as described in reference 1. The maximum measured value of these coefficients was selected to calculate drag owing to viscous effect. Drag coefficients of 0.065 for vane set 3 and of 0.089 for vane set 4 were obtained from the previous IST data of 1982.

Pitching Moment Coefficient

The pitching-moment coefficient was determined about the vane quarter chord from the integration of the 1/10-scale chordwise surface-pressure data, except for vane sets 3 and 4. The maximum measured value from the 1/10-scale tests was used for the load calculation. The pitching moment coefficients for vane sets 3 and 4, which were analyzed as flat plates at angle of attack, were obtained from reference 8.

Dynamic Pressure

For the 40 x 80 mode, the dynamic pressure for global load was obtained by three-dimensional integration of the total-pressure surveys in front of the vane sets from the 1/50-scale model of the 40 x 80 tunnel. These surveys were taken at the horizontal centerline and at the vertical location of maximum total-pressure profile with the test-section empty. The integration method is described in appendix A. An air-exchange rate of 10%, the maximum anticipated, was used since the loads will be higher for vane sets 2, 3, 5, and 6 with the air-exchange open.

The spanwise variation (floor to ceiling) of dynamic pressure along the vane span was determined from the measurement of the 1/50 scale model. This profile was reduced to full scale by the method described in the following section (Calculation Method).

The jet- and propeller-wake dynamic pressure profiles at affected vane sets were obtained by the method described in appendix B.

For the 80 x 120 mode, the dynamic pressure profile without the jet or propeller wake was assumed to be uniform at any given station within the tunnel circuit.

Vane Splitter Plate Drag Coefficient

A drag coefficient of 0.025 was selected for a local lift coefficient of 0.8 using a NACA 0012 airfoil. This drag coefficient was doubled to account for the intersection effect of the splitter plate with the vane.

Vane-Surface Roughness

A drag coefficient of 0.02 was determined from the 1/10-scale test data with a number 70 carborundum grit buildup on the vane surface. This value was doubled for the load calculation to account for vane-surface roughness owing to buildup from jet engine exhaust contamination.

CALCULATION METHOD

Global Loads

Global loads were calculated using equations from reference 9. These equations were used to calculate the global loads for vane sets 1, 2, 5, 6, 7, and 8. Global loads for each of the aforementioned vane sets were calculated using identical equations; however, each vane set had a correction coefficient or a set of correction coefficients to take into account such factors as the dynamic pressure profiles (q profiles); the splay angles of the vane set (vane set 5 only; see appendix C); and, for vane sets 2, 4 and 5, the effect of jet-exhaust or propeller-wake impingement on the vane set.

The basic equations that were used are as follows:

$$V_{z1} = V_{z2}$$

$$V_{z1} = V_1 \cos \beta_1$$

$$\text{Drag} = \frac{1}{2} \rho V_z^2 (\tan^2 \beta_2 - \tan^2 \beta_1) A + \frac{\Delta p}{q} \times A \times q$$

$$\text{Lift} = \rho V_z^2 (\tan \beta_1 - \tan \beta_2) A$$

The sign convention for the above equations is shown below. (Note that the direction for drag is opposite to that used in ref. 9.)

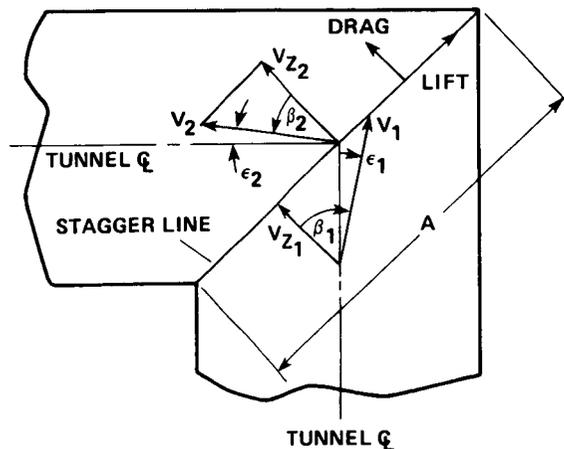

The equations used to calculate these component loads are presented below. To minimize errors these equations were programmed on a computer.

Drag Loads- Global drag is composed of viscous drag of the smooth vanes, inviscid drag of the vanes, drag on the splitter plates including interference effects at the splitter-plate vane intersections, and drag owing to vane-surface roughness. Equations for component drag loads are as follows:

$$\begin{aligned} \text{Viscous drag} &= q_{AVG} A_n F_3 \\ \text{Inviscid drag} &= \frac{1}{2} \rho V_z^2 (\tan^2 \beta_2 - \tan^2 \beta_1) A F_3 \\ \text{Roughness drag} &= q_{AVG} A \left(\frac{P}{q}\right)_s F_3 \\ \text{Splitter plate drag} &= 4 q_{AVG} A_{sp} (c_d)_{sp} F_3 \end{aligned}$$

Additional drag loads owing to impingement of a vortex, jet, or propeller wake were calculated for vane set 1 (40 x 80 mode) and vane sets 4 and 5, (80 x 120 mode). Vortex loads were inputs in the program. The calculation of these loads is described in reference 10. Loads owing to jet or propeller wakes were obtained from the dynamic pressure distribution using the method shown in appendix B.

The global drag for a particular vane set is the summation of the above loads.

Global Lift- Global lift is the lift owing to momentum effects across the vane set. The momentum lift is calculated using the following equation:

$$\text{Momentum lift} = \rho V_z^2 (\tan \beta_1 - \tan \beta_2) A F_3$$

Global Pitching Moment- The pitching moment was calculated in two steps. The pitching moment per vane span was first calculated and then the total pitching moment was calculated by multiplying this value by the total span length of the vane set. The equations used are

$$\begin{aligned} \text{Pitching moment/span} &= q_{AVG} c_m c^2 F_3 \\ \text{Pitching moment} &= \text{pitching moment/span} \times \text{span} \end{aligned}$$

The equations presented in the above sections were used to calculate both the global design and the global operating loads. The following general notes apply to all vane sets. For specific vane sets there are additional notes on the corresponding summary sheets.

1. Loads are acting at the 1/4 chord location except as noted
2. Lift loads are acting along the vane set with the positive direction toward the outside wall

3. Drag loads are perpendicular to the vane set

Rolling Moment- Global rolling moments about the vane mid-span for vane sets 1 and 5 were calculated for the load resulting from a trailing vortex generated by a model wing. The vortex center was assumed to be located at the horizontal centerline of the wind tunnel.

Local Loads

The maximum lift, drag, and pitching moments along the span of an individual vane were calculated. These include effects of model jet- and propeller-wake impingement and trailing-vortex impingement for the affected vanes set. For vanes that are supported by trusses, the truss effects are included. The following are the assumptions made to calculate loads:

1. The 1/50-scale measured vertical q -profile represents the maximum profile of the vane set
2. The measured vertical q -profile in front of a vane in the 1/50-scale model of the wind tunnel is proportional to the full-scale q -profile, the constant of proportionality being equal to the ratio of the test section q 's.
3. Adjustments for differences in air-exchange rate between the model and full-scale tunnels is linear scaling of the flow velocities from the 1/50-scale data
4. Mass flux through the vane set is constant regardless of inflow angle
5. Vortex and jet impingement do not occur simultaneously
6. Vane set 3 experiences the same q -distribution as vane set 2
7. Cascade equations for lift and drag of reference 9 apply to all vanes (exceptions noted)

The following equations were used to determine loads:

1. Full scale local q (lb/ft²):

$$q_v = [1 + (m_{fs} - m_{50})/100^2][\cos(sa)/\cos \beta_1]^2 [(q_{fst}/q_{50t})q_{50}]$$

The first term of equation (1) corrects for differences in the air-exchange rate between the full-scale and 1/50-scale tunnels. The second term insures the constancy of the mass flux through the vane set. The last term is based on assumption (2) above.

2. Viscous drag (lb/ft):

$$D_v = \eta P q_v$$

3. Inviscid drag (lb/ft):

$$D_i = P \cos^2(\beta_1)(\tan^2 \beta_2 - \tan^2 \beta_1)q$$

4. Inviscid lift (lb/ft):

$$L_i = 2P \cos^2 \beta_1(\tan \beta_1 - \tan \beta_2)q$$

5. Pitching moment about 1/4-chord (ft·lb/ft):

$$M = c^2 c_m q_V$$

6. Loads due to vortex:

$$D_{vor} \text{ (lb/ft)}$$

$$L_{vor} \text{ (lb/ft)}$$

$$M_{vor} \text{ (ft·lb/ft)}$$

7. Loads due to jet or propeller wake:

$$q_{jet} \text{ (lb/ft}^2\text{)}$$

$$D_v \text{ (lb/ft)} = \eta P q_{jet}$$

$$D_\xi \text{ (lb/ft)} = P \cos^2 \beta_1(\tan^2 \beta_1 - \tan^2 \beta_2)q_{jet}$$

$$L_i \text{ (lb/ft)} = 2P \cos \beta_1(\tan \beta_1 - \tan \beta_2)q_{jet}$$

$$M \text{ (ft·lb/ft)} = c^2 c_m q_{jet}$$

8. Loads due to trusses (see appendix D):

$$D_{truss} \text{ (lb/ft)} = 39.34 q_v \text{ (or } q_{jet}\text{)}$$

value calculated using $c_d = 1.7$ (ref. 11)

$$L_{truss} \text{ (lb/ft)} = 0$$

$$M_{truss} \text{ (ft·lb/ft)} = 221.09 q_v \text{ (or } q_{jet}\text{)}$$

The lift and drag forces are parallel and perpendicular, respectively, to the vane stagger line. To translate the forces to the plane of a vane, the following equations were used:

$$DDT \text{ (lb/ft)} = (D_i + D_v) \cos(sa) - L_i \sin(sa)$$

$$LLT \text{ (lb/ft)} = L_i \cos(\alpha) + (D_i + D_v)\sin(\alpha)$$

Vortex Loads

The three-dimensional panel code VSAERO (ref. 12) was used in evaluating the effect of vortex wakes originating from unpowered models on the turning vanes. The analytical method for calculating these loads for the affected vane sets is discussed in reference 10. Loads from vortex-wake effects were based on a model lift of 100,000 lb for both 40 x 80 and the 80 x 120 operation.

Jet-Exhaust and Propeller-Wake Effects

The effect of an axisymmetrical jet wake and a propeller wake (parallel to the free stream) owing to a powered model was considered for the vane-set downstream of the test section for both the 40 x 80 and 80 x 120 modes. This effect results in a dynamic pressure increase at the vane set over that when the wind tunnel is operated without the model. Only the direct impingement effect of the jet and propeller wakes was studied. The vortex effect induced by the exhaust flow field was not considered.

40 x 80 Mode- The dynamic pressure distribution including the effect of the jet or propeller wake in front of vane set 1 was determined by satisfying the conservation of mass and energy laws between the test section and the vane set and by utilizing a jet-wake decay model from reference 13. The method used to determine the dynamic pressure distribution is described in appendix B. A uniform dynamic pressure distribution without the jet is determined by the method of reference 14. The difference between the two distributions at the vane set is assumed to be the effect of the jet or propeller wake. This effect is added to the dynamic pressure distribution obtained from the 1/50-scale-model measurements, which include the effects of the boundary-layer growth and the wakes of the diffuser columns located at the center of the primary diffuser.

80 x 120 Mode- The dynamic pressure distribution in front of vane sets 4 and 5 was determined with the jet wake by satisfying the conservation of mass and energy and by utilizing a jet decay model of reference 13. The walls between the test section and the vane sets were assumed to be parallel. The method used to calculate these distributions is given in appendix B.

LOAD CALCULATION INPUTS

The inputs required to calculate global design, global operating, local design, and local operating loads are as follows:

1. Wind tunnel circuit velocity and dynamic pressure profiles

2. η values and outflow angles
3. Chordwise surface-pressure distributions of the vane
4. c_m values
5. Vortex-wake loads for affected vane sets
6. Jet and propeller dynamic pressure profiles for affected vane sets

These inputs will be discussed for each vane set.

Vane Sets 1 and 2

The 1/50-scale facility total-pressure surveys in front of vane sets 1 and 2 are shown in figures 10 and 11, respectively. The horizontal surveys show a total-pressure defect at the tunnel centerline owing to the wake of nine vertical structures spanning from the floor to the ceiling columns and located in series at the centerline of the primary diffuser. The scaling of these survey data to full scale for sets 1 and 2 is shown in tables 2 and 3, respectively.

The variation of η -value and outflow angle with onset angle for sets 1 and 2 is shown in figure 12. Chordwise surface-pressure distributions of several vanes are shown in figure 13 for two onset angles. The pitching moment about the 1/4-chord was obtained by integrating these distributions. The variation of c_m with onset angle is shown in figure 14.

Since vane set 1 is located approximately 340 ft downstream of the test section, this vane set will be affected by the impingement of the vortex wake or propeller wake originating from the model. The magnitude of the vortex load, which is based on a model lift of 100,000 lb is shown in figure 15. The vane spanwise vortex load and rolling moment were obtained from this figure.

The incremental dynamic pressure increases across the vane span owing to an axisymmetric jet and propeller wake are shown in figure 16(a), using the method described in appendix B. These increases are based on the following engine and propeller performance data:

Designation	Thrust, lb	Nozzle or rotor diam, ft	T_o , R°	M, lb/sec	Press ratio	Test section conditions	
Turbofan A	16,000	2.00	1424	252	2.81	U_{ts} , ft/sec	506.70
						P_s , lb/ft	1858.30
Turbofan B	19,800	2.83	1163	415	1.98	ρ , slugs/ft ³	0.00204
						T_{ts} , R°	529.60
						Q_{ts} , lb/ft ²	261.88
JVX rotor-propeller	3,000 @ 300 knots 14,000 @ 0 knots	25.00	---	---	---	A_{TC} , ft ²	2754.59

These performances are current maximum allowable operating values for a model in the 40 x 80 tunnel. The q-increment was added to the vertical dynamic pressure profile without the jet, which is shown in figure 16(b). The center of the wake was assumed to be 27 ft from the tunnel center and impinged the vane set 367 ft from the test section (fig. 16(b)). This location coincides with the maximum dynamic pressure location of figure 10(a) to provide maximum local loads. A jet spreading rate of 0.128 was used to determine the radial velocity distribution. This rate equals a spreading angle of 7.27° ($\phi = \tan^{-1} 0.128$). The angle was obtained from the classic jet spreading angle of 5.50° ($\phi = \tan^{-1}(1/108)$) from reference 13 and adding 62.5% of the primary diffuser half angle of 2.83° to account for the jet spreading caused by the expanding area of the diffuser.

Vane Set 3

In the 40 x 80 mode, the velocity and dynamic pressure profiles of vane set 3 were assumed to be the same as for vane set 2, since 1/50-scale model surveys were not taken in front of vane set 3. This assumption was made because the vane set is located in the constant-area duct of the tunnel circuit adjacent to vane set 2. An η -value of 0.065 was derived from the vane set 4 η -value of 0.089 which was obtained during the 80 x 120 IST of 1982. Since vane sets 3 and 4 have the same design except for chord, the η -value was obtained by multiplying 0.089 by the vane-set-3-to-vane-set-4 chord ratio and was assumed to be constant with onset angle. To calculate pitching moment, the flat plate c_m data of reference 8 were used (fig. 17), since the vanes were considered to be flat plates. The truss drag and pitching moment were calculated by the following equations:

$$D_{\text{truss}} = 39.34 q$$

$$M_{\text{truss}} = 221.09 q$$

The derivation of these coefficients is shown in appendix D. When the vane-set forms a wall during 80 x 120 operation, the dynamic pressure in front of vane set 5 was used to determine truss loads.

Vane Set 4

The dynamic pressure profile was assumed to be uniform for the 80 x 120 mode. This pressure was calculated using a boundary-layer displacement thickness correction of 0.5 ft. This displacement thickness was measured during the 80 x 120 IST of 1982. An η value of 0.089, which was obtained from the 80 x 120 IST data of 1982, was assumed constant with onset angle. Values of c_m for a flat plate were used to calculate pitching moment, as shown in figure 17. To calculate the truss drag and pitching moment, the equations of vane set 3 were used since the truss dimensions of the two vane sets are nearly equal. Vane 4C space truss drag load and pitching moment about the vane 1/4 chord were calculated from a drag coefficient of 0.7 (ref. 15) for the elliptical cross section shown in figure 4(c) and an assumed moment arm of 2.64 ft normal to the vane surface, respectively. Figure 18 shows the vortex loads that are based on a model lift of 100,000 lb.

The variation of dynamic pressure and temperature to determine maximum local load with jet effect is shown in figures 19(a) and 19(b), respectively, as a function of vane span. The center of the jet wake was assumed to be offset 1/4 of the tunnel width from the tunnel centerline, and the jet origin was located 205 ft from the vane set.

Vane Set 5

The velocity and dynamic pressure profiles for vane set 5 without the jet effect are tabulated in table 4 for the 40 x 80 mode. These profiles are based on the 1/50-scale total-pressure surveys in front of the vane set, as shown in figure 20. The variation of the η -value and the outflow angle with onset angle is shown in figure 21 for both the 40 x 80 mode and 80 x 120 mode. Chordwise surface pressure distributions on three vanes are shown in figure 22 for several onset angles for both modes of tunnel operation. To determine the load on the vane directly adjacent to the west wall for the 80 x 120 mode, lift, drag, and pitching moment coefficients of the vane adjacent to the wall (fig. 22(e)) were used. The variations of c_m with onset angle is shown in figure 23. Figure 24 shows the spanwise loads owing to a vortex wake. Global loads owing to vortex drag and rolling moment were calculated using this figure. Global drag load owing to the vortex was computed by assuming a positive drag across the vane span and a one-half load decrease between each vane. Rolling moment owing to the vortex was computed about the vane midspan.

The variations of the dynamic pressure and temperature across the vane span to determine the maximum local loads with jet and propeller wakes are shown in figures 25(a) and 25(b), respectively. To determine global loads with jet and propeller wakes, two wake centers were assumed to be located symmetrically 0.18 of the tunnel width from the tunnel centerline across the vane set width and at the tunnel centerline across the vane span. The variation of the maximum dynamic pressure profile across the vane set width and vane span is shown in figures 26(a) and 26(b), respectively, with the wake origin 303 ft from the vane set. The profile is based on a single jet or propeller operating in the test section of the 80 x 120 tunnel with no interaction effect between the two wakes. The use of this profile for the case of two jet or propeller wakes was considered adequate for the first estimation of global loads.

Vane Set 6

The 1/50-scale total-pressure surveys in front of vane set 6 with the flaps deflected 80° is shown in figure 27 for 40 x 80 operation. The scaling of these surveys to full scale is shown in table 5. The variation of η with onset angle is shown in figure 28. The chordwise surface-pressure distributions for onset angles of 0° to 5° obtained from the 1/10-Scale Vane-Set Test Facility are shown in figure 29. These distributions were used to determine the vane set c_m , the flap normal force coefficient $(c_n)_f$, and $(c_m)_f$ about the flap hinge line as shown in figures 30 and 31, respectively. Since data were obtained only at 0° onset angle for $\delta_f = 0^\circ$, $c_{mc}/4$, c_{nf} , and c_{mf} values at $\pm 3.4^\circ$ onset angle and 0° flap deflection were obtained by assuming that the variation of these values with flap deflection at $\pm 3.4^\circ$ onset angle is the same as the variation with flap deflection at 0° onset angle. Onset angles of $\pm 3.4^\circ$ were selected for load calculations since this angle represents the half angle of the diffuser sidewall upstream of vane set 6.

Vane Set 7

For the 80 x 120 mode, a uniform dynamic pressure of 4.7 lb/ft² in front of the vane set was assumed for a test section q of 33.18 lb/ft² (100 knots). This value was obtained by extrapolating the 80 x 120 IST data of 1982 as shown in figure 32. An onset flow angle of 0° and an outflow angle of 40° at the vane set exit were used to determine global loads. The outflow angle was based on laser-Doppler velocimeter measurements of the 1/50-scale model of the 40 x 80 tunnel, as shown in figure 33. An η -value of 1.73 was derived from figure 32 assuming the exit static pressure as atmospheric. For determining local loads, the vanes were considered as infinite-aspect-ratio flat plates at an angle of attack of 45°. With these assumptions, a center of pressure location at 44% chord from the leading edge was determined from reference 16. A bird-screen pressure-loss coefficient of 0.470 was determined for an onset angle of 0° from reference 17 and was verified using 1/10-scale data with a porosity correction from reference 18. This value was used to determine the pressure-drag coefficient of 0.349 in the drag direction and the tangential-force coefficient of 0.143 with an outflow angle of 40°, using the method of

reference 19. The structural members were considered as infinitely long flat plates with an onset angle of 45° . A lift and drag coefficient of 1.2 based on the wind axis from reference 16 was used to determine the local load on these structural element.

For the 40×80 mode a uniform dynamic pressure of 2.89 lb/ft^2 was assumed in front of the vane set, which corresponds to an air exchange of 10%. The air-exchange mass flow is based on a ratio of test-section velocity with and without air exchange equal to 0.94, as shown in reference 7. The static pressure in front of the vane set was determined to be 2128.2 lb/ft^2 from figure 32, and the static pressure at the exit of the vane set was assumed to be at atmospheric pressure. Except as noted in this paragraph, all assumptions and inputs to compute loads were the same as those described for the 80×120 mode.

Vane Set 8

The full-scale velocity and dynamic pressure profiles for vane set 8 are tabulated in table 6. These profiles are based on the 1/50-scale total-pressure surveys in front of the vane set, as shown in figure 34. The variation of η and outflow angle with onset angle as determined from 1/10-scale tests are shown in figure 35. Chordwise surface-pressure distributions for several onset angles are shown in figure 36. The variation of c_m with onset angle is shown in figure 37.

RESULTS

Several load cases were computed for each vane set. Maximum global design loads, global operating load, and maximum local design loads were determined from these cases. The load cases that were considered, along with the inputs, are tabulated in tables 7 through 13. The global design, global operating, and local vane spanwise loads are shown in figures 38 through 53. The remainder of this section will discuss the results for each vane set.

Vane Sets 1 and 2

Since the vane design and frontal area are the same for vane sets 1 and 2, global and local loads of both vane sets are considered together in this section. The load cases considered are shown in table 7.

Maximum global design and operating loads from these cases are presented in figures 38(a) and 38(b), respectively, along with the sign convention of the loads. Figures 38(c) and 38(d) show tabulated global design loads of vane sets 1 and 2, respectively, for the load cases considered.

For the local design load, vane set 1 is more critical than vane set 2 because of the additional load owing to vortex, jet, or propeller wake effects. Maximum estimated local design loads were obtained at an onset angle of 3.0° and an outflow angle of 0° for lift, and at an onset angle of -3.0° and an outflow angle of -4.0° for drag. The vane spanwise local loads with vortex-, jet-, and propeller-wake effects are shown in figure 39. For the jet-wake effect, only turbofan A was considered since the dynamic pressure distributions of turbofans A and B are approximately equal. Loads were calculated with vortex, jet, and propeller wakes acting at the vane midspan and coinciding with a horizontal location in the diffuser where the maximum dynamic pressure occurred without these wake effects (see fig. 10(b)), that is, between the walls of the diffuser and the support columns down the centerline of the diffuser. The vortex effect is more critical than the jet or propeller effect at vane set 1 because of the higher drag load, as shown in figure 40.

Vane Set 3

For the 40×80 mode, only the vane spanwise loads were computed since global loads can be obtained from these loads. Because vanes 3I and 3L are located in an area where the vertical dynamic pressure profile is a maximum, the local design loads were calculated for these vanes (see fig. 3(a)). These loads for vane 3 are shown in figure 41 for the load cases shown in table 8. The two values of onset angle used to calculate local design loads provided maximum positive and negative lift values.

For the 80×120 mode, in which the vane set forms a wall, the maximum estimated wall-pressure differential is 62 lb/ft^2 based on IST measurements of 1982. The loads owing to the vane truss (see fig. 4) are shown in figure 41(g).

Vane Set 4

Only the local design and local operating loads were calculated for this vane set. For the 80×120 mode, vane 4C (fig. 4(a)) was selected to determine these loads because its aerodynamic surface area is maximum among the vanes. Local loads were obtained for onset angles of 0° , 3° , 5° , and 10° , and for an outflow angle of 0° , as shown in table 9, for the following conditions:

1. No vortex- or jet-wake effects
2. Vortex-wake effect acting at the vane midspan
3. Jet- and propeller-wake effects acting at the vane midspan

Graphs of these loads are shown in figures 42(a) through 42(l), and tabulated values are shown in figures 42(m) through 42(x). The effect of vortex, jet, and propeller wakes on the spanwise vane loads is shown in figure 43 for the operating load at onset and outflow angles of 0° . For most cases, the wake effect increases loads; however, the vortex wake decreases the pitching moment and has no effect on the

drag. For the case of $\epsilon_1 = \epsilon_2 = 0$ the peak lift, drag, and pitching moments with the propeller wake are approximately double those with no wake effect.

For the 40 x 80 mode, the vane set forms a wall. The maximum estimated wall-pressure differential is 62 lb/ft² based on IST measurements of 1982. The loads owing to the vane spanwise truss (fig. 3) and vane 4C space truss are shown in figure 44.

Vane Set 5

The global and local loads for vane set 5 were calculated for both the 40 x 80 mode with 10% air exchange and the 80 x 120 mode. The load cases considered are shown in table 10. Using the method described in appendixes A and C, the calculation of the global loads for the 40 x 80 mode include the effect of the nonuniform dynamic pressure profile and the effect of vane splay angle. For the 80 x 120 mode, the loads owing to the impingement of a lift-generated vortex wake, a jet wake, and a propeller wake were also determined. Maximum global design and global operating loads with no vortex-, jet-, or propeller-wake effects for both modes of operation are shown in figures 45(a) and 45(b), respectively.

For the 80 x 120 mode, the effect of the vortex-wake center acting at the vane midspan on the maximum global design loads is to increase drag 12% and to add a rolling moment, as shown in figure 45(c). The effect of jet-wake and propeller-wake centers acting at the vane midspan is to increase the maximum loads and pitching moment as shown in figures 45(d) and 45(e), respectively. These loads were calculated based on two wake centers that were located symmetrically at 18% of the vane-set width from the tunnel circuit centerline.

For the 80 x 120 mode, tabulated global design loads with no wake effects, vortex-wake effect, jet-wake effect, and propeller-wake effect for the load cases considered are shown in figures 45(f) through 45(i), respectively. For the 40 x 80 mode, tabulated global design loads for the load cases considered are shown in figure 45(j).

Maximum local lift and drag loads for the 80 x 120 mode were selected from the load cases presented in figure 45(a). These loads are presented in figures 46(a) through 46(f) and tabulated in detail in figures 46(g) through 46(l).

The vane adjacent to the west wall in the 80 x 120 circuit will have higher local loads because of wall effects. These loads are shown in figure 46(m), using the aerodynamic coefficient shown in figure 22(e).

Maximum local loads for the 40 x 80 mode were determined along a vertical line where the dynamic pressure is expected to be the highest. The onset angles for these calculations are 3° and -3°, which result in a maximum positive and negative lift load, respectively. The local loads based on these angles are shown in figures 47(a) through 47(d) for an air exchange rate of 10%.

Vane Set 6

Global loads were calculated for the 40 x 80 mode with 10% air exchange and for the 80 x 120 mode for the vane set 6 cases shown in table 11. An onset angle of $\pm 3.4^\circ$ (see fig. 7) was selected because it is the half angle of the diffuser wall upstream of the vane set.

The global design and operating loads are shown in figures 48(a) and 48(b), respectively, for both modes. Since the flap loads are handled structurally independent of the fixed vanes, the loads per foot of vane span on the trailing-edge flaps are also included in these figures for both modes of operation. These loads were calculated from trailing-edge flap normal and hinge moment coefficients shown in figure 31.

The loads on the fixed part of the vane for the 80 x 120 mode are also shown in figures 48(a) and 48(b). For the 40 x 80 mode, the local loads on the fixed part of the vane were computed at $z/W = 0.100$ and 0.414 , as shown in figure 49. These two locations were selected because, as shown in figure 49, the dynamic pressure is highest along these vertical lines.

The factors needed to determine the outer corner vane local load owing to the wall effect were obtained by the ratio of the 1/10-scale integrated pressure coefficients between the vanes near the wall and the vanes at the center of the vane sets. These factors are:

$$L_{CV} = 1.71 L_{mv}$$

$$D_{CV} = 2.28 D_{mv}$$

$$M_{CV} = 1.81 M_{mv}$$

Vane Set 7

Since the outflow angle of vane set 6, which is located just upstream of vane set 7, can be adjusted by deflecting the trailing-edge flaps, the aerodynamic global design and global operating loads of vane set 7 were considered equal. Both the global and local loads for the 80 x 120 mode and the 40 x 80 mode, based on the inputs shown in table 12, are summarized in figure 50. Detailed calculations to determine these loads are shown in appendix E. The global load was determined (1) by the method of reference 9 for a cascade vane set for which the onset and outflow velocities normal to the vane stagger line are assumed and (2) by a momentum principle that accounts for the higher exit velocity owing to the blockage of the structure and bird screen. The higher lift and drag loads calculated from these methods were selected to provide a conservative estimate of the loads.

The local vane load was obtained by assuming a vane angle of 45° using the momentum principle. This load was translated normal and parallel to the vane surface.

The local bird-screen lift and drag loads were determined assuming a 10% wake blockage upstream of the screen. This increased the onset dynamic pressure by 21% relative to what it would be with no blockage correction.

Vane Set 8

Global and local loads for vane set 8 were calculated for the load cases shown in table 13 for the 40 × 80 mode. Maximum global design and operating loads are shown in figures 51(a) and 51(b), respectively. The global design loads for the load cases considered are tabulated in figure 51(c).

The local design loads at the center of the vane set are shown in figures 52(a) through 52(d). For the load cases considered, the maximum vane lift distributed along the vane span is obtained at an onset angle of 3.0° and at an outflow angle of -4.8°, as shown in figure 52(b); and maximum vane drag distributed along the vane span is obtained at an onset angle of -3.0° and at an outflow angle of -6.8°, as shown in figure 52(d). These outflow angles were obtained from figure 35. The data of figures 52(a) through 52(d) are tabulated in figure 53.

CONCLUDING REMARKS

Maximum global and local loads have been determined for each turning vane set of the National Full-Scale Aerodynamic Complex (NFAC). Analytical methods to determine these loads have been presented. An intensive effort was undertaken to predict these loads with a minimum of uncertainties by the use of experimental data. These data were obtained from the 1/10-Scale Vane-Set Facility and the 1/50-Scale Facility of the NFAC. Additional loads on the vane sets owing to a vortex wake, a jet wake, or a propeller wake originating from a test model were also considered.

APPENDIX A

THREE-DIMENSIONAL INTEGRATION OF THE DYNAMIC PRESSURE PROFILES
ACROSS A VANE SET

The integration method is based on a vertical total-pressure survey and a horizontal total-pressure survey of the 1/50-scale 40- by 80-Foot Wind Tunnel model across a vane set. The following assumptions were made to scale the 1/50-scale data to full scale:

1. The 1/50-scale profiles represent maximum total-pressure measurements of the vane set

2. The 1/50-scale profiles can be scaled using the ratio of the test section dynamic pressures

The 1/50-scale total-pressure profiles were reduced to dynamic pressure profiles by assuming a constant static pressure and dividing by 1/50-scale test-section dynamic pressure:

$$\frac{q_n}{q_{50ts}} = \frac{Y \times \text{CONV} \times 144}{x \times 5.19} \quad (\text{A1})$$

$$\frac{q_v}{q_{50ts}} = \frac{z \times \text{CONV} \times 144}{x \times 5.19} \quad (\text{A2})$$

where Y and z are the total-pressure profiles in front of the vane set along horizontal and vertical centerlines of the tunnel circuit, respectively, as measured in the 1/50-scale mode.

The above ratios are multiplied by the full-scale test-section dynamic pressure and adjusted for the air-exchange difference between full scale and 1/50 scale according to the following formulas:

$$q_h = \frac{q_n}{q_{50ts}} \times q_{fst} \times \left[\frac{1 + m_{fs}/100}{1 + m_{50}/100} \right]^2 \quad (\text{A3})$$

$$q_v = \frac{q_v}{q_{50ts}} \times q_{fst} \times \left[\frac{1 + m_{fs}/100}{1 + m_{50}/100} \right]^2 \quad (\text{A4})$$

These local q values are divided by an average q value in front of the vane set. This average q value is based on a velocity that conserves mass throughout the wind-tunnel circuit according to the following formulas:

$$V_{AVG} = (1 + m_{fs}/100)W_{fstS}/A_{TC} \times \rho \times 32.2 \quad (A5)$$

$$q_{AVG} = \frac{1}{2} \rho (V_{AVG})^2 \quad (A6)$$

Velocity profile ratios along the horizontal and vertical survey lines are computed as follows:

$$V_H/V_{AVG} = (q_H/q_{AVG})^{0.5} \quad (A7)$$

$$V_V/V_{AVG} = (q_V/q_{AVG})^{0.5} \quad (A8)$$

$$(V/V_{max})_H = (V_H/V_{AVG})/(V_H/V_{AVG})_{max} \times V_H/V_{AVG}/(V_H)_{max}/V_{AVG} \quad (A9)$$

$$(V/V_{max})_V = (V_V/V_{AVG})/(V_V/V_{AVG})_{max} \times V_V/V_{AVG}/(V_V)_{max}/V_{AVG} \quad (A10)$$

The local velocity ratios are integrated three dimensionally by the trapezoidal rule and are iterated until the law of continuity is satisfied.

The integration is based on the following assumptions:

1. The variations of local velocity profiles with vane span or vane-set width are the same as the measured profiles except for magnitude
2. The magnitude of these profiles can be determined by the ratio of the local velocity to the maximum local velocity as determined from the 1/50-scale surveys
3. The density is constant

$$\rho \int_{z=0}^{1.0} (V/V_{max})_V dz/V_S \int_{y=0}^{1.0} (V_H/V_{AVG}) dy/W = M \quad (A11)$$

$$M = (y/W)(z/V_S)(V_{AVG}/V_{AVG})(\rho) = \rho \cdot 1.0 \quad (A12)$$

$$\int_{z=0}^{1.0} (V/V_{max})_V dz/V_S \int_{y=0}^{1.0} (V_H/V_{AVG}) dy/W = 1.0 \quad (A13)$$

The final adjusted $(V_H/V_{AVG})_{FINAL}$ ratio which satisfies the law of continuity is used to determine the final dynamic pressure ratio:

$$\frac{q_H}{q_{AVG}} = \left(\frac{V_H}{V_{AVG}} \right)_{FINAL}^2 \quad (A14)$$

The dynamic pressure ratios are integrated three dimensionally by the trapezoidal rule to determine the mean dynamic pressure value:

$$F_3 = \frac{\int_{z=0}^{1.0} (v/v_{\max})^2 dz/v_s \int_{y=0}^{1.0} (q_H/q_{AVG}) dy/W}{\int_{z=0}^{1.0} dz/v_s \int_{y=0}^{1.0} dy/W} \quad (A15)$$

$$q_m = F_3 q_{AVG} \quad (A16)$$

APPENDIX B

JET-EXHAUST AND PROPELLER-WAKE EFFECTS

40 x 80 Mode

For the 40 x 80 mode, the dynamic-pressure distribution in front of vane set 1, which is located at the primary diffuser exit downstream of the test section, is determined by satisfying the conservation of mass and energy and utilizing a jet decay model of reference 13. The sketch below is a plan view of the 40 x 80 tunnel.

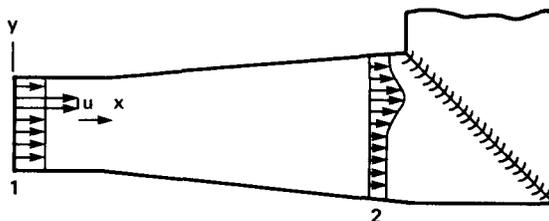

Conservation of mass:

$$\int_{A_1} \rho_1 U_1 dA = \int_{A_2} \rho_2 U_2 dA \quad (B1)$$

Conservation of energy:

$$\int_{A_1} \rho_1 U_1 (c_p T_1 + U_1^2/2) dA = \int_{A_2} \rho_2 U_2 (c_p T_2 + U_2^2/2) dA \quad (B2)$$

At station 1 the free-stream condition and jet engine or propeller performances are assumed to be known with an axisymmetrical jet exhaust or propeller wake. For the jet case, the jet-exhaust conditions at the nozzle exit are determined by the following equations for a given thrust, mass-flow rate, stagnation temperature, pressure ratio, and nozzle exit diameter.

$$U_J = F_J/m_J \quad (B3)$$

$$\rho_J = m_J/A_J U_J \quad (B4)$$

$$M_J = U_J/\sqrt{\gamma g R T_J} \quad (B5)$$

$$T_J = T_{0J}/[1 + (\gamma - 1)/2 M_J^2] \quad (B6)$$

} solved iterately

$$P_J = \rho_J RT_J \quad (B7)$$

$$P_{0J} = P_J [1 + (\gamma - 1)/2M_J^2]^{\gamma/\gamma-1} \quad (B8)$$

$$PR = P_{0J} / P_{0ts} \quad (B9)$$

For the propeller case (see the following sketch) the velocity and diameter of the wake are determined by the following equations for given thrust and propeller diameter. The static pressure and air density upstream and downstream of the propeller are assumed to equal the free-stream values.

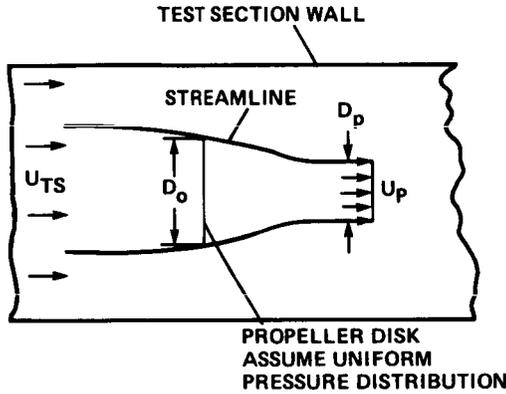

$$U_p = \left[U_{ts}^2 + \frac{2F_p}{\rho_{ts} A_o} \right]^{1/2} \quad (B10)$$

$$D_p = D_o \left[\frac{U_p + U_{ts}}{2U_p} \right]^{1/2} \quad (B11)$$

At station 2, the wake-velocity decay was determined utilizing the similarity forms presented in reference 10 for an axisymmetric jet.

$$\frac{(U_J - U_2)}{(U_{Jts} - U_2)} = K_1 / (X/D_J) \sqrt{\rho_J / \rho_{ts}} \quad \text{Decay of jet-wake centerline velocity} \quad (B12)$$

$$\frac{(U_P - U_2)}{(U_{Pts} - U_2)} = K_1 / (X/D_P) \sqrt{\rho_P / \rho_{ts}} \quad \text{Decay of propeller-wake centerline velocity}$$

$$\frac{(T_{JC} - T_2)}{(T_{Jts} - T_{ts})} = K_2 / (X/D_J) \quad \text{Decay of jet-wake centerline temperature} \quad (B13)$$

$$\frac{(T_{pC} - T_2)}{(T_{Pts} - T_{ts})} = K_2 / (X/D_P) \quad \text{Decay of propeller-wake centerline temperature}$$

$(U - U_2)/(U_{JC} - U_2) = \rho - (r/\sigma_U x)^2$	Jet-wake velocity profile	
		(B14)
$(U - U_2)/(U_{pC} - U_2) = \sigma - (r/\sigma_U x)^2$	Propeller-wake velocity profile	
$(T - T_2)/(T_{JC} - T_2) = \rho - (r/\sigma_T x)^2$	Jet-wake temperature profile	
		(B15)
$(T - T_2)/(T_{pC} - T_2) = \rho - (r/\sigma_T x)^2$	Propeller-wake temperature profile	
$K_1/K_2 = 62/5.27$	Determined empirically (ref. 13)	(B16)
$\sigma_U^2/\sigma_T^2 = 72/108$	Determined empirically (ref. 13)	(B17)

The free-stream conditions outside of the wake at station 2 are determined from the test conditions, assuming isentropic flow outside the jet.

$$P_{ts}/\rho_{ts}^Y = P_2/\rho_2^Y \quad (B18)$$

$$c_p T_1 + U_1^2/2 = c_p T_2 + U_2^2/2 \quad (B19)$$

$$P_2 = \rho_2 R T_2 g \quad (B20)$$

The static pressure at station 2 is assumed to be uniform in the plane normal to the flow:

$$\rho_J = P_2/RT_J g \quad (B21)$$

The flow conditions at station 2 are determined by iterating equations 1 and 2 together with equations (12) through (21). The converged solution gives the static pressure at station 2 (P_2) and the jet decay rate (K_1) required to satisfy the above equation set.

80 x 120 Mode

The dynamic pressure distribution is calculated by satisfying the conservation of mass and momentum between the test section and the section in front of the vane set. Parallel walls are assumed between the two sections. A plan view of the 80 x 120 test section is shown below.

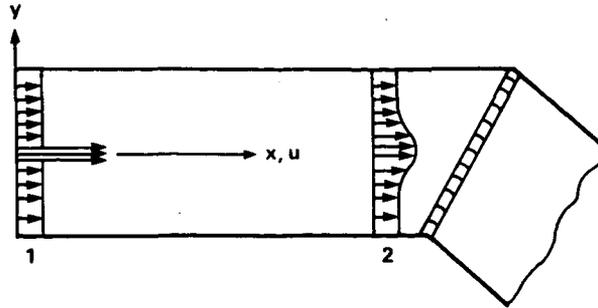

PLAN VIEW OF 90-BY 120 WIND TUNNEL TEST SECTION

Conservation of mass:

$$\int_{A_1} \rho_u dA = \int_{A_2} \rho_u dA \quad (B22)$$

Conservation of momentum:

$$\int_{A_1} (p_1 + \rho u_1^2) dA = \int_{A_2} (p_2 + \rho u_2^2) dA \quad (B23)$$

where $dA = dy dz$.

The same equations ((3) through (21)) and assumptions discussed for the 40 × 80 mode were used to determine the flow conditions at station 2, along with equations (22) and (23). These equations were solved iteratively. The converged solution gives the static pressure at station 2, P_2 , and the jet spreading rate, σ_u , required to satisfy the equation set.

APPENDIX C

VANE SET 5 CORRECTION FACTORS TO GLOBAL LOADS

Vane set 5 has a variation of splay angle correction factors with no jet or propeller wake, and the splay angle is treated as an outflow angle. This splay angle is added to the outflow angle obtained from the 1/10 scale data without splay.

$$\beta_2 = sa + \epsilon_2 + \sigma \quad (C1)$$

$$\beta_2 = sa + \epsilon_2 \quad \text{when } \sigma = 0 \quad (C2)$$

Correction factors are obtained to correct for the variation of splay angle and dynamic pressure by the three-dimensional integration method described in appendix A. These factors are applied to the global load equations shown in a preceding section (Calculation Method) in the main body of the report.

$$L = \rho V_z^2 (\tan \beta_1 - \tan \beta_2) A \iint_A (V/V_{\max})^2 (V_{z\ell}/V_z)^2 \frac{(\tan \beta_1 - \tan \beta_2^2)}{(\tan \beta_1 - \tan \beta_2)} dz dy \quad (C3)$$

$$V_z = V_{\text{AVG}} \cos \beta_1 \quad (C4)$$

$$V_z = V_H \cos \beta_1 \quad (C5)$$

$$V_{z\ell}/V_z = V_H \cos \beta_1 / V_{\text{AVG}} \cos \beta_1 = (V_H/V_{\text{AVG}}) \quad (C6)$$

$$(V_{z\ell}/V_z)^2 = (V_H/V_{\text{AVG}})^2 \quad (C7)$$

$$F_1 = \iint_A (V/V_{\max})^2 (V_H/V_{\text{AVG}})^2 \frac{(\tan \beta_1 - \tan \beta_2')}{(\tan \beta_1 - \tan \beta_2)} dz dy \quad (C8)$$

$$L = \rho V_z^2 (\tan \beta_1 - \tan \beta_2) A F_1 \quad (C9)$$

$$D = \frac{1}{2} \rho V_z^2 (\tan^2 \beta_2 - \tan^2 \beta_1) A \iint_A (V/V_{\max})^2 (V_z/V_z)^2 \frac{(\tan^2 \beta_2' - \tan^2 \beta_1)}{(\tan^2 \beta_2 - \tan^2 \beta_1)} dz dy$$

$$+ \frac{1}{2} \rho (V_z/\cos \beta_1)^2 \eta A \iint_A (V/V_{\max})^2 (V_{z\ell}/V_z)^2 dz dy \quad (C10)$$

$$F_2 = \iint_A (V/V_{\max})^2 (V_H/V_{\text{AVG}})^2 \frac{(\tan^2 \beta_2' - \tan^2 \beta_1)}{(\tan^2 \beta_2 - \tan^2 \beta_1)} dz dy \quad (C11)$$

$$F_3 = \iint_A (V/V_{\max})^2 (V_H/V_{\text{AVG}})^2 dz dy \quad (\text{same as appendix A}) \quad (C12)$$

$$D = \frac{1}{2} \rho V_z^2 (\tan^2 \beta_2 - \tan^2 \beta_1) A F_2 + \frac{1}{2} \rho (V_z / \cos \beta_1)^2 \eta A F_3 \quad (C13)$$

For the case of a single jet or propeller wake or dual jets or propeller wakes originating from the test section of the 80 x 120 tunnel, the values for V and q can be expressed as

$$\frac{V_{y,z}}{V_{AVG}} = \frac{V_r}{V_{AVG}} \quad (C14)$$

$$\frac{q_{y,z}}{q_{AVG}} = \frac{q_r}{q_{AVG}} \quad (C15)$$

where r = distance from the jet- or propeller-wake centerline to the y,z location of interest.

The constants F₁, F₂, and F₃ are then determined by integrating the appropriate expressions.

$$F_1 = \iint_A q_r / q_{AVG} (\tan \beta_1 - \tan \beta_2 / \tan \beta_1 - \tan \beta_2) dz dy \quad (C16)$$

$$F_2 = \iint_A q_r / q_{AVG} (\tan^2 \beta_2 - \tan^2 \beta_1 / \tan^2 \beta_2 - \tan^2 \beta_1) dz dy \quad (C17)$$

$$F_3 = \iint_A q_r / q_{AVG} dz dy \quad (C18)$$

APPENDIX D

TRUSS LOAD AND PITCHING MOMENT

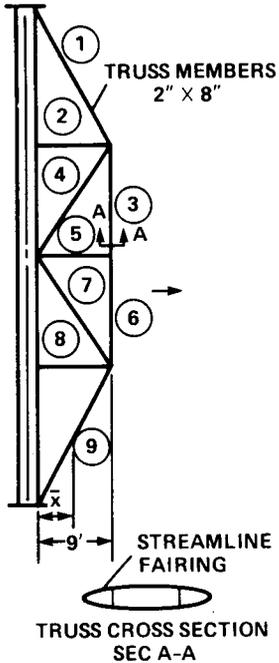

Assume truss geometry same for each vane		Typical calculation vane 3 J&K		
Truss member location	Truss frontal area using vane set geometry, ft ²	Drag = (1.7 x area x 58.42), lb	\bar{X} , ft	PM = \bar{X} x drag, ft·lb
1	19 x 0.1 = 3.23	321	4.5	1,443
2	8.7 x 0.17 = 1.48	147	4.5	661
3	17 x 0.17 = 2.89	287	9	2,583
4	19 x 0.17 = 3.23	321	4.5	1,443
5	8.7 x 0.17 = 1.48	147	4.5	661
6	17 x 0.17 = 2.89	287	9	2,583
7	19 x 0.17 = 3.23	321	4.5	1,443
8	8.7 x 0.17 = 1.48	147	4.5	661
9	19 x 0.17 = 3.23	321	4.5	1,443
Total	23.14	2,298	5.62	12,925

$$\text{Solidity} = \text{solid area/open area} = 23.14 / (9(16.7)(34)(9))$$

$$= 23.14 / 456 = 0.05$$

$$c_d = 1.7 \text{ (ref. 11)}$$

$$\begin{aligned} \text{Truss drag} &= (c_d)(q)(23.14) \\ &= 1.7(23.14)q \\ &= 39.34q \end{aligned}$$

$$\begin{aligned} \text{Truss pitching moment} &= (39.34)(5.62)q \\ &= 221.09q \end{aligned}$$

Use above equations for vane sets 3 and 4 since truss dimensions are nearly equal for both vane sets.

APPENDIX E

VANE SET 7 LOAD CALCULATIONS

GLOBAL LOAD CALCULATION FOR 80 x 120 CIRCUIT

Flow Area Downstream of the Bird Screen

1. 12-in. width exposed columns (8PL) = $(8 \times 12)(12 \times 128.7) = 1030 \text{ ft}^2$
 2. Horizontal beam (9 in., 10PL and 12 in. 1PL)
 $= (197.2 - 8)[(10 \times 9/12) + (12/12)] = 1608 \text{ ft}^2$
 3. Diagonal bracing in front of bird screen (six horizontal rows, nine vertical rows), $5 \times 5 \times 1/4$ in.
 $= 6 \times 9 \times (5/12) \times 30 \times 2 = \underline{1350 \text{ ft}}$
- 3988 ft^2

4. Exposed bird-screen blockage
 $[1 - (0.75 - 0.1055)^2 / 0.75^2] = 0.262$ of open area
 $SB = 0.226 (24,690 - 3988)$

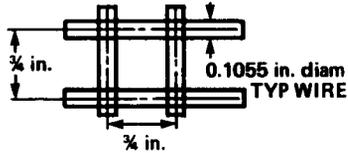

$$= 0.226 (20,702)$$

$$= 5424 \text{ ft}^2$$

5. Bird-screen edge effect; assume 45% bird-screen blockage
6. Flow area perpendicular to exit flow deflected 40° :

$$\begin{aligned} A_{\text{exit}} &= (24,690 - 3988 - 0.45 \times 5424) \cos 40^\circ \\ &= 18,261 \cos 40^\circ \\ &= 13,989 \text{ ft}^2 \end{aligned}$$

Assumptions

1. Flow deflected 40° from horizontal by vane set with bird screen
2. $V_1 = 62.78 \text{ ft/sec}$
3. Weight rate of flow = 119,007 lb/sec

4. $P_1 = 2128.20 \text{ lb/ft}^2$, $T_1 = 60^\circ \text{ F}$

5. $P_2 = 2116.80 \text{ lb/ft}^2$, $T_2 = 60^\circ \text{ F}$

6. $A_1 = 24,690 \text{ ft}^2$

Exit velocity:

$$\rho_2 = \frac{2116.80}{53.3 \times 520 \times 32.2} = 0.002372 \text{ slugs/ft}^3$$

$$V_2 = \frac{119.007}{13,989 \times 0.002372 \times 32} = 111.38 \text{ ft/sec}$$

Global Load Using Impulse Momentum Equations

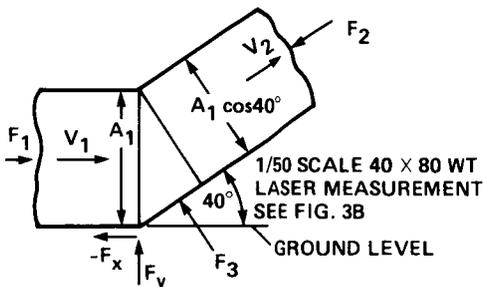

F_x and F_y structural force acting on the fluid within the boundary. Forces due to fluid on structure equal and opposite in sign.

$$F_1 = P_1 A_1 \text{ (assume uniform pressure distribution)}$$

$$F_2 = P_2 A_2 \cos 40^\circ \text{ (assume uniform pressure distribution)}$$

$$F_3 = P_2 A_1 \sin 40^\circ \text{ (assume uniform pressure distribution)}$$

$$P_1 = 2128.20 \text{ lb/ft}^2$$

$$P_2 = 2116.80 \text{ lb/ft}^2$$

$$-F_x + F_1 - F_2 \cos 40^\circ - F_3 \sin 40^\circ = W/g(V_2 \cos 40^\circ - V_1)$$

$$-F_x + P_1 A_1 - P_2 A_1 \cos^2 40^\circ - P_2 A_1 \sin^2 40^\circ = W/g(V_2 \cos 40^\circ - V_1)$$

$$-F_x + A_1(P_1 - P_2) = W/g(V_2 \cos 40^\circ - V_1)$$

$$-F_x = \frac{119.007}{32.2} (111.38 \cos 40^\circ - 62.78) - 24.690(2128.20 - 2116.8)$$

$$-F_x = 83.312 - 281,466$$

$$F_x = 189,154 \text{ lb}$$

$$F_y - F_2 \sin 40^\circ + F_3 \cos 40^\circ = W/g(V_2 \sin 40^\circ)$$

$$F_y - P_2 A_1 \cos 40^\circ \sin 40^\circ + P_2 A_1 \cos 40^\circ \sin 40^\circ = W/g(V_2 \sin 40^\circ)$$

$$F_y = W/g(V_2 \sin 40^\circ)$$

$$F_y = 119,007/32.2(111.38 \sin 40^\circ)$$

$$F_y = 264,600 \text{ lb}$$

$$F_x = 198,154 \text{ lb; use } 198,000 \text{ lb}$$

$$F_y = -264,600 \text{ lb; use } -265,000 \text{ lb}$$

Global Loads Using Cascade Equation of Reference 9

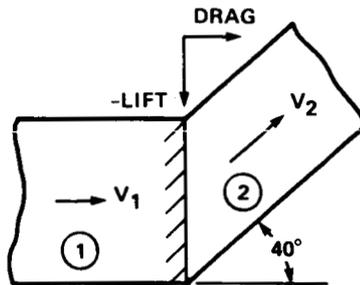

$$\text{Assume } P_{S2} = 2116.8 \text{ lb/ft}^2, T_2 = 60^\circ\text{F}$$

For 80 x 120 mode:

$$P_{T1} = 2116.8 + 16.1 = 2132.90 \text{ lb/ft}^2 \text{ } \left. \begin{array}{l} \text{extrapolated } 80 \times 120 \text{ IST data} \\ \text{(see fig. 32)} \end{array} \right\}$$

$$P_{S1} = 2116.8 + 11.4 = 2128.20 \text{ lb/ft}^2$$

$$q_1 = 2132.90 - 2128.20 = 4.7 \text{ lb/ft}^2$$

$$\rho_1 = 2128.20 / [53.3(32.2)(520)]$$

$$= 0.002384 \text{ slugs/ft}^3$$

$$V_1 = [2(4.7)]^{0.5} / (0.002384) = 62.78 \text{ ft/sec}$$

$$W = 119,007 \text{ lb/sec (wt. rate of flow at 100 knots in test section)}$$

$$A_1 = 119,007 / [62.79(0.002384)(32.2)] = 24.690 \text{ ft}^2$$

$$V_2 = V_1 / \cos 40^\circ$$

$$V_2 = 62.78 / \cos 40^\circ = 81.95 \text{ ft/sec}$$

$$\rho_2 = 2116.8 / [53.3(32.2)(520)] = 0.002372 \text{ slugs/ft}^3$$

$$q_2 = 0.5(0.002372)(81.95)^2 = 7.96 \text{ lb/ft}^2$$

$$\Delta p_t/q_1 = [2132.9 - (2116.8 + 7.96)]/4.7 = 1.73$$

$$\begin{aligned} \text{Lift} &= \rho_1 V_1^2 A_1 (\tan \beta_1 - \tan \beta_2) \\ &= 0.002384 (62.78)^2 (24,690) (\tan 0^\circ - \tan 40^\circ) \\ &= -194,663 \text{ lb; use } -195,000 \text{ lb} \end{aligned}$$

$$\begin{aligned} \text{Drag} &= 0.5 \rho_1 V_1^2 A_1 (\tan^2 \beta_2 - \tan^2 \beta_1) \Delta p_t A_1 q_1 \\ &= 0.5 (0.002384) (62.78)^2 (24,690) (\tan^2 40^\circ) + 1.73 (4.7) (24,690) \\ &= 81,671 + 200,754 \\ &= 282,425 \text{ lb; use } 282,000 \text{ lb} \end{aligned}$$

Since the calculations methods using cascade equations and momentum equations give different results, use higher loads from either method to give conservative estimate.

LOCAL VANE LOADS AND PITCHING MOMENT USING TWO-DIMENSIONAL FLAT-PLATE DATA

The input is $\alpha = 45^\circ$, infinite aspect ratio, neglect blunt leading edge;
 $c_l = 1.2$; $c_d = 1.2$; x_{cp} (from L.E.) = $0.440c$ (ref. 16).

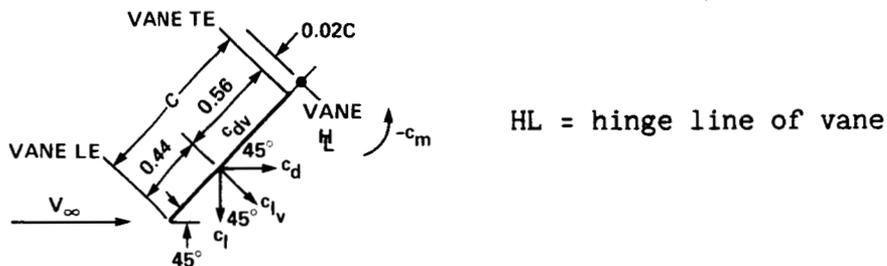

$$\begin{aligned} (c_m)_{\text{vane HL}} &= -c_l (0.58 \cos 45^\circ) - c_d (0.58 \sin 45^\circ) \\ &= -c_l (0.410) - c_d (0.373) \\ &= -1.2 (0.410) - 1.2 (0.373) \\ &= -0.492 - 0.448 \\ &= -0.94 \end{aligned}$$

$$\begin{aligned}
 (\text{Pitching moment/ft of vane span}) &= (c_m)q_{vs7}c^2 \\
 &= -0.940(4.7)(10.54) \\
 &= -491 \text{ ft-lb/ft of vane span about vane HL}
 \end{aligned}$$

$$\begin{aligned}
 \text{Total vane span} &= \Sigma \text{ panel width} \times \text{number of rows} \\
 &= 189.5(12) \\
 &= 2274 \text{ ft}
 \end{aligned}$$

$$\text{Global pitching moment} = -491(2274) = -1,116,534 \text{ ft}\cdot\text{lb}$$

Translate lift and drag coefficient from wind axis to vane axis:

$$\begin{aligned}
 c_L &= c_d \sin 45^\circ - c_l \cos 45^\circ \\
 c_L &= -1.2 \sin 45^\circ - 1.2 \cos 45^\circ \\
 c_D &= -c_d \cos 45^\circ - c_l \sin 45^\circ \\
 c_D &= 0
 \end{aligned}$$

Total lift perpendicular to vane surface:

$$\begin{aligned}
 \text{Local lift/ft of vane span} &= -1.7(4.7)(10.54) \\
 &= -84 \text{ lb/ft of vane span}
 \end{aligned}$$

LOCAL VANE LOADS USING MOMENTUM PRINCIPLE

Outflow velocity of vane = 104.5 ft/sec (see below, Vane Set 7: 80 x 120 Mode Screen Drag and Lift).

$$\text{Vane lift} = \frac{-119,007}{32.2} \times 104 \sin 45^\circ \quad \text{Momentum principle}$$

$$\text{Vane lift/vane span} = \frac{-273,000}{2274} = -120 \text{ lb/ft}$$

Since flat plate two-dimensional lift and drag coefficients are equal at an angle of attack of 45°, assume vane drag equals vane lift.

Translate forces to vane axis:

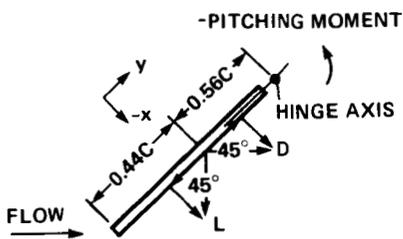

$$F_x = -L \cos 45^\circ - D \sin 45^\circ$$

$$F_y = D \cos 45^\circ - L \sin 45^\circ$$

$$F_x = -120 \cos 45^\circ - 120 \sin 45^\circ$$

$$= -170 \text{ lb/ft of vane span}$$

$$F_y = 120 \cos 45^\circ - 120 \sin 45^\circ$$

$$= 0$$

For vane center of pressure location, use same location as two-dimensional flat plate (see above, Local Vane Loads and Pitching Moment Using Two-Dimensional Flat-Plate Data).

$$\frac{\text{Vane pitching moment about vane hinge point}}{\text{vane span}} = F_x \times 0.56 \times \text{vane chord}$$

$$= -170 \times 0.56 \times 10.54$$

$$= -1003 \text{ ft}\cdot\text{lb/ft of span}$$

$$\text{Total global pitching moment} = -1003 \times 2274$$

$$= -2,280,000 \text{ ft}\cdot\text{lb (Use -2,300,000 ft}\cdot\text{lb)}$$

Use above results since these results are higher than those obtained by considering the vane as a flat plate.

STRUCTURAL BLOCKAGE LOAD

Input:

Structural members are infinitely long flat plates with approach velocity equaled to the exit velocity. Approach angle 45°.

Dynamic pressure ahead of structural member:

$$q_v = 13.02 \text{ lb/ft}^2$$

$$c_l = 1.2, c_d = 1.2 \text{ along wind axis at } \alpha = 45^\circ \text{ (ref. 16)}$$

Local loads on structure:

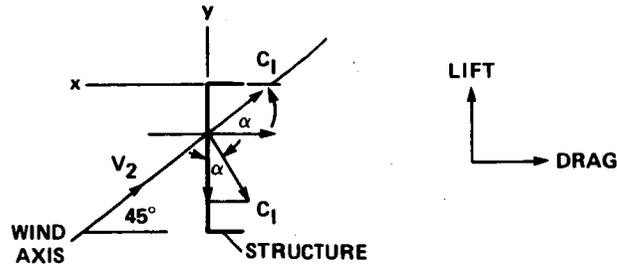

$$(c_1)_y = (-c_1 \cos \alpha + c_d \sin \alpha)$$

$$(c_1)_y = (-1.2 \cos 45^\circ + 1.2 \sin 45^\circ)$$

$$(c_1)_y = 1.7$$

$$(c_d)_x = (-c_1 \sin \alpha + c_d \cos \alpha)$$

$$(c_d)_x = (-1.2 \sin 45^\circ + 1.2 \cos 45^\circ)$$

$$(c_d)_x = 1.7$$

For 12-in.-wide column and 12-in.-wide channel:

$$\frac{\text{Structure drag along x-axis}}{\text{ft of structure span}} = 1.7(13.02)1 = 22.1 \text{ lb/ft of structural span}$$

For 9-in.-wide column:

$$\frac{\text{Structure drag along x-axis}}{\text{ft of structure span}} = 1.7(13.02)9/12 = 16.6 \text{ lb/ft of structural span}$$

BIRD-SCREEN LOADS

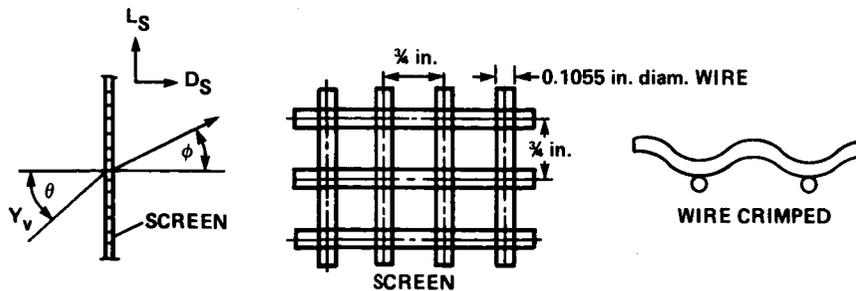

Symbols:

V_v mean velocity averaged over time

θ angle of flow incidence measured from normal to screen

ϕ angle of flow exit measured from normal to screen

K_θ pressure-drop coefficient when angle of incidence is θ and angle of exit is ϕ

F_θ tangential-force coefficient when angle of incidence is θ and angle of exit is ϕ

K pressure-drop coefficient when $\theta = 0$

α limiting value of ϕ/θ as θ approached zero

1. Input:

$\phi = 40^\circ$ based on 1/50-scale 40 x 80 tunnel laser measurement (see fig. 33)

2. Solution:

$$K = K_{rn} K_{mesh} \{ [1 - (A_{flow}/A)] + [A/A_{flow}] - 1 \}^2 \text{ (ref. 17)}$$

K_{mesh} = mesh screen-type loss parameter

K_{mesh} = 1.0 for new metal wire and 1.3 for average circular metal wire;
use 1.3 for calculation to account for grit buildup

K_{rn} = function of Reynolds number (RN)

K = pressure loss coefficient

$$RN = (\rho V D_{mesh}) / \mu$$

where: ρ = mass density, slugs/ft³
 μ = absolute viscosity, lb·sec/ft²

$$\mu \times 10^{10} = 0.3170 T^{(3/2)} [734.7 / (T + 216)]$$

$$\mu \times 10^{10} = 0.3170 (520)^{1.5} [(734.7 / (520 + 216))]$$

$$\mu = 3752 \times 10^{-10}$$

$$RN = \frac{0.002372(111.56)(0.1055/12)}{37.52 \times 10^{-10}}$$

$$= 6,200$$

$$K_{rn} = 1.0$$

$$A_{flow} = (0.75 - 0.1055)^2 = 0.4154 \text{ in.}^2$$

$$A = (0.75)^2 = 0.5625 \text{ in.}^2$$

$$K = \{1.0(1.3)[1 - (0.4154/0.5625)]\} + [(0.5625/0.4154) - 1]^2$$

$$K = 0.47 \text{ (for } \theta = 0^\circ)$$

$$\alpha = 1.1/(1 + K)^{1/2} \text{ (ref. 18)}$$

$$= 1.1/(1 + 0.47)^{1/2}$$

$$= 0.907$$

$$\alpha = \phi/\theta$$

$$\theta = 40/0.907 = 44.1^\circ \text{ for } \phi = 40^\circ$$

$$F_\theta/\theta = 2(1 - \alpha) \text{ (ref. 18)}$$

$$F_\theta = 2(44.1/57.3)(1 - 0.907) = 0.143$$

Vane Set 7: Screen Loss Coefficient--Alternative Method

$$\Delta p_t/q = [\text{constant } (1 - \beta)/\beta^2](Re_\beta)^{-0.33} \text{ (ref. 19)}$$

Δp_t = total pressure loss across screen

q = onset flow dynamic pressure

β = screen porosity = $(1 - d/l)^2$ for square mesh

Re_β = modified Reynolds number

$$= (Ud)/\beta v$$

$$U = [(2q)/\rho]^{1/2}$$

ρ = density (0.002377 lb sec²/ft⁴)

$$\nu = \text{kinematic viscosity } (1.5723 \times 10^{-4} \text{ ft}^2/\text{sec})$$

constant = 5.5 (provides good comparison with 1/10-scale model component screen tests)

$$\beta = [1 - (0.1055/0.75)]^2 = 0.7385$$

$$Re_{\beta} = \{[104.5(0.1055)]/[0.7385(1.5723 \times 10^{-4})]\} = 94,953$$

$$\Delta p_t/q = [5.5(1 - \beta)(600)^{-0.33}]/\beta^2 \text{ for } Re_{\beta} > 600$$

$$\Delta p_t/q = [5.5(1 - 0.7385)(600)^{-0.33}]/(0.7385)^2 = 0.319 \text{ (with new smooth wire)}$$

Effects of wire crimp:

	<u>Crimped wire</u>	<u>Smooth wire</u>	
$\Delta p_t/q =$	2.04	- 1.60	= 0.44 with 46% porosity (1/10-scale test data)

Effects of dirt on wire:

	<u>Dirty</u>	<u>Clean</u>	
$\Delta p_t/q =$	(0.20	0.17)	= 0.03 with 84% porosity (1/10-scale test data)

Correction to 73.85% screen porosity:

$$\text{Corr} = [(1 - \beta)/\beta^2]0.7385/[(1 - \beta)/\beta^2]_{\text{test porosity}}$$

$$(\Delta p_t/q)_{\text{total}} = (\Delta p_t/q)_{\text{new wire}} + (\Delta p_t/q)_{\text{wire crimp}} + (\Delta p_t/q)_{\text{dirt}}$$

$$= [0.319 + 0.44(4927/2.552) + 0.03(0.4927/0.2209)]$$

$$= 0.319 + 0.085 + 0.067$$

$$= 0.471 \text{ (for } \theta = 0^\circ) \text{ (checks with method of ref. 17)}$$

Vane set 7: Bird-Screen Drag and Lift

$$F_{\theta} = [2 \cos \theta \sin(\theta - \phi)]/\cos \phi \text{ (ref. 18)}$$

$$= [(2 \cos 44.1^\circ \sin(44.1^\circ - 40^\circ)]/\cos 40^\circ$$

$$= 0.134$$

$$F_{\theta} = [K_{\theta} \sin(\theta - \delta)]/1 + \cos(\theta - \delta) \text{ where } \theta - \delta = 25 \text{ (ref. 19)}$$

$$\delta = (44.1^\circ - 40^\circ)/2 = 2.05^\circ$$

$$\begin{aligned}
K_{\theta} &= F_{\theta} [1 + \cos(\theta - \delta)] / \sin(\theta - \delta) \\
&= [0.134(1 + \cos(44.1^{\circ} - 2.05^{\circ}))] / \sin(44.1^{\circ} - 2.05^{\circ}) \\
&= [0.134(1 + \cos 42.05^{\circ})] / \sin 42.05^{\circ} \\
&= 0.349
\end{aligned}$$

$$K_{\theta} = K(\cos \theta)^{1.1} \quad (\text{empirical equation based on 1/10-scale tester data})$$

$$K_{\theta} = 0.47 \cos(44.1^{\circ})^{1.1}$$

$$K_{\theta} = 0.325$$

Area calculation upstream of bird screen with blockage of vane thickness:

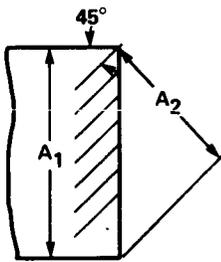

Panel blockage area = total width of panels times panel thickness times the number of horizontal panel rows

$$\begin{aligned}
\text{Panel blockage area} &= 189.5 \text{ ft}(6 \text{ ft}/12)(12) \\
&= 1137 \text{ ft}^2
\end{aligned}$$

$$\begin{aligned}
A_2 &= A_1 \cos 45^{\circ} - 1137 \\
A_2 &= 24,690 \cos 45^{\circ} - 1137 \\
A_2 &= 16,321 \text{ ft}^2
\end{aligned}$$

Onset velocity ahead of screen:

$$V_v = 119,007 / (0.002384)(32.2)(16,321) = 94.99 \text{ ft/sec (with no wake blockage)}$$

Vane Set 7: 80 x 120 Mode Screen Drag and Lift
(Assume wake blockage equals 10%)

$$V_v = 1.1(95) = 104.5 \text{ ft/sec (with wake blockage)}$$

$$\begin{aligned}
q_v &= 1/2(0.002384)(104.5)^2 \\
&= 13.02 \text{ lb/ft}^2
\end{aligned}$$

Use $K_{\theta} = 0.349$, $F_{\theta} = 0.143$ values to provide conservative estimates.

$$\begin{aligned}
\text{Screen drag} &= K_{\theta}(q_v) \\
&= 0.349(13.02) \\
&= 4.5 \text{ lb/ft}^2
\end{aligned}$$

$$\begin{aligned}
 \text{Screen lift} &= F_{\theta}(q_v) \\
 &= 0.143(13.02) \\
 &= 1.9 \text{ lb/ft}^2
 \end{aligned}$$

GLOBAL LOAD CALCULATION FOR 40 x 80

Vane Set Configuration

All of vane segments ("D" panels of fig. 8) at the southwest corner of the vane set 7 in place and opened permanently for both 40 x 80 mode and 80 x 120 mode operation.

Inputs

1. 10% air exchange for 40 x 80 mode with angle of onset flow 0° and angle of outflow 40°.
2. Test section conditions:

$$P_s = (2116.8 + 9) - 273 = 1852.8 \text{ lb/ft}^2$$

$$T_s = 70^\circ$$
3. Test section velocity with 10% air exchange = 0.94 (velocity with no air exchange).
4. Test section velocity with no air change = 300 knots.
5. Test section area with acoustic liner = 2754.59 ft².

Onset and Outflow Velocity Calculation

Onset velocity for vane set 7, 40 x 80 mode:

$$\begin{aligned}
 V_{ts} &= 0.94(300)(1.688) \\
 &= 476.02 \text{ ft/sec}
 \end{aligned}$$

$$\begin{aligned}
 \rho_{ts} &= 1852.8/530(53.3)(32.2) \\
 &= 0.002037 \text{ slug/ft}^3
 \end{aligned}$$

$$\begin{aligned}
 W_{ts} &= 2754.59(0.002037)(32.2)(476.02) \\
 &= 86006 \text{ lb/sec}
 \end{aligned}$$

$$\begin{aligned}
 \text{Vane set 7 exit weight rate of flow} &= 0.10(86006) \\
 &= 8600 \text{ lb/sec}
 \end{aligned}$$

$$\begin{aligned}\text{Vane set 7 frontal area} &= (\text{vane set height}) \times (\text{vane segment width}) \\ &= 128.7 \times 17.85 \\ &= 2297 \text{ ft}^2\end{aligned}$$

$$\begin{aligned}\text{Assume: } P_{s1} &= 2116.8 + 9 = 2125.80 \text{ lb/ft}^2 \\ T_{s1} &= 70^\circ\text{F}\end{aligned}$$

$$\rho_1 = 2125.8 / (53.3)(32.2)(530) = 0.002337 \text{ slug/ft}^3$$

$$V_1 = 8600 / (2297)(0.002337)(32.2) = 49.75 \text{ ft/sec}$$

Outflow velocity with structural and bird screen edge effect:

$$\begin{aligned}\text{Horizontal structure beam (9 in. [, 10PL, and 12 in. [, 1 PL)} &= 17.85[90/12 + 1] \\ &= 152 \text{ ft}^2\end{aligned}$$

$$\text{Bird screen effect} = 0.262(2297 - 152)(0.45)$$

Flow area perpendicular to exit flow deflected 40°

$$A_{\text{exit}} = (2297 - 152 - 253)\cos 40^\circ = 1449 \text{ ft}^2$$

$$\begin{aligned}\text{Assume: } P_{s2} &= 2116.8 \text{ lb/ft}^2 \\ T_{s2} &= 70^\circ\end{aligned}$$

$$\rho_2 = 2116.8 / (53.3)(32.2)(530) = 0.002327 \text{ slug/ft}^3$$

$$V_2 = 8600 / (1449)(0.002337)(32.2) = 79.21 \text{ ft/sec}$$

Global Load Using Impulse Momentum Equations

$$-F_x + A_1(P_1 - P_2) = W/g[V_2 \cos 40^\circ - V_1]$$

$$\begin{aligned}-F_x &= [8600/32.2(79.2/\cos 40^\circ - 49.75^\circ)] - 2297[2125.8 - 2116.8] \\ &= 2919 - 20,673\end{aligned}$$

$$F_x = 17,754$$

$$\begin{aligned}F_y &= W/g(V_2 \sin 40^\circ) \\ &= 8600/32.2(79.21 \sin 40^\circ) \\ &= 13,599 \text{ lb}\end{aligned}$$

Air load on structure equal and opposite to the directions to that shown above:

$$\begin{aligned}F_y &= -13,599 \text{ lb; use } 13,600 \text{ lb} \\ F_x &= 17,754 \text{ lb; use } 17,800 \text{ lb}\end{aligned}$$

Global Loads Using Cascade Equation (ref. 9)

$$V_1 = 49.75 \text{ ft/sec}$$

$$\rho_1 = 0.002337 \text{ slug/ft}^3$$

$$\Delta P_t/q_1 = 1.73 \text{ from extrapolated data of } 80 \times 120 \text{ IST data (see preceding section, Global Loads Using Cascade Equation of Reference 9, for calculation)}$$

$$\begin{aligned} \text{Lift} &= \rho_1 V_1^2 A_1 (\tan \beta_1 - \tan \beta_2) \\ &= 0.002337 (49.75)^2 (2297) (-\tan 40^\circ) \\ &= -11,149 \text{ lb} \end{aligned}$$

$$\begin{aligned} \text{Drag} &= 1/2 \rho_1 V_1^2 A_1 (\tan^2 \beta_2 - \tan^2 \beta_1) + \Delta P_t/q_1 (q_1) (A_1) \\ &= 1/2 (0.002337) (49.75)^2 (2297) (\tan^2 40^\circ) + 1.73 (0.5) (0.002337) \\ &\quad \times (49.75)^2 (2297) \\ &= 4677 + 1.73 (2.89) (2297) \\ &= 4677 + 11,493 \\ &= 16,170 \text{ lb} \end{aligned}$$

Final Global Loads

$$\text{Lift} = -13,600 \text{ lb using impulse-momentum equation}$$

$$\text{Drag} = 17,800 \text{ lb using impulse-momentum equation}$$

LOCAL LOADS FOR 40 x 80 MODE

Vane Loads

$$\text{Vane outflow velocity} = 82.87 \text{ ft/sec (see following subsection, Bird-Screen Loads)}$$

$$\begin{aligned} \text{Vane lift} &= -8600/32.2 (82.87 \sin 45^\circ) \\ &= -15,650 \text{ lb} \end{aligned}$$

$$\text{Vane lift/vane span} = -15,650/214 = -73 \text{ lb/ft}$$

Since flat plate two-dimensional lift and drag are equal for $\alpha = 45^\circ$, assume vane drag equals vane lift:

Vane drag = 73 lb/ft

Translate lift and drag to vane axis:

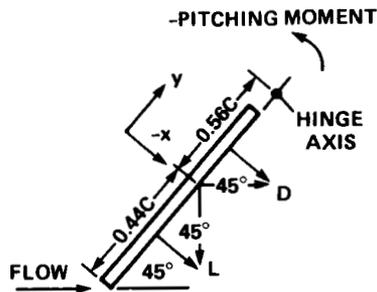

$$\begin{aligned}
 F_x &= -L \cos 45^\circ - D \sin 45^\circ \\
 F_x &= -73(\cos 45^\circ + \sin 45^\circ) \\
 &= -103 \text{ lb/ft of span} \\
 F_y &= D \cos 45^\circ - L \sin 45^\circ \\
 F_y &= 73 \cos 45^\circ - 73 \sin 45^\circ \\
 F_y &= 0
 \end{aligned}$$

For vane center of pressure location, use same location as two-dimensional plate (see earlier subsection, this appendix, Local Vane Loads and Pitching Moment Using Two-Dimensional Flat-Plate Data).

$$\begin{aligned}
 \frac{\text{Vane pitching moment above vane hinge point}}{\text{Vane span}} &= F_x(0.56c)(\text{vane cord}) \\
 &= -103(56)(10.54) \\
 &= -608 \text{ ft}\cdot\text{lb/ft}
 \end{aligned}$$

Total global pitching moment = $-608(214) = -130,112 \text{ ft}\cdot\text{lb}$; use $-130,000 \text{ ft}\cdot\text{lb}$.

Bird-Screen Loads

Area perpendicular to flow at 45° with vane thickness of blockage:

$$\begin{aligned}
 A &= 2297 \cos 45^\circ - (17.85(6/12))(12) \\
 A &= 1624 - 107 \\
 A &= 1517 \text{ ft}^2
 \end{aligned}$$

Onset velocity at screen

$$\begin{aligned}
 V_v &= 8600/0.002337(32.2)(1517) \\
 V_v &= 75.34 \text{ ft/sec without wake blockage}
 \end{aligned}$$

Assume wake blockage = 10%:

$$\begin{aligned}
 V_v &= 1.1(75.34) = 82.87 \text{ ft/sec} \\
 q_v &= 1/2(0.002337)(82.87)^2 \\
 &= 8.02 \text{ lb/ft}^2
 \end{aligned}$$

(Use same loss coefficient as shown in earlier subsection, this appendix, Vane Set 7: Bird-Screen Drag and Lift.)

$$\text{Screen drag/area} = 0.349(8.02) = 2.80 \text{ lb/ft}^2$$

$$\text{Screen lift/area} = 0.143(8.02) = 1.15 \text{ lb/ft}^2; \text{ use } 1.2$$

Structural Loads Perpendicular to Structure Surface

$$C_d = 1.7 \text{ (see earlier subsection, this appendix, Structural Blockage Load)}$$

$$\text{Local drag/ft of structural span} = 1.7(8.02)(12/12) = 13.63 \text{ lb/ft for } 12 \text{ in. [}$$

$$\text{Local drag/ft of structural span} = 1.7(8.02)(9/12) = 10.23 \text{ lb/ft for } 9 \text{ in. [}$$

REFERENCES

1. Corsiglia, Victor R.; Olson, Lawrence E.; and Falarski, Michael D.: Aerodynamic Characteristics of the 40- by 80-/80- by 120-Foot Wind Tunnel at NASA Ames Research Center. NASA TM-85946, 1984.
2. Dudley, M. R.; Unnever, G.; and Regan, D. R.: Two-Dimensional Wake Characteristics of Inlet Vanes for Open-Circuit Wind Tunnels. AIAA Paper 84-0604, San Diego, Calif., 1984.
3. Mort, K. W.; Engelbert, D. F.; and Dusterberry, J. C.: Status and Capabilities of the National Full-Scale Facility. AIAA Paper 82-0607, Williamsburg, Va., 1982.
4. Norman, T. R.; and Johnson, W.: Estimating Unsteady Aerodynamic Forces in a Cascade in a Three-Dimensional Turbulence Field. NASA TM-86701, 1985.
5. Norman, T. R.: Unsteady Aerodynamic Load Estimates on Turning Vanes in the National Full-Scale Aerodynamic Complex. NASA TM-88191, 1986.
6. Rossow, V. J.; Schmidt, G. I.; et al.: Aerodynamic Characteristics of an Air-Exchange System for the 40- by 80-Foot Wind Tunnel At Ames Research Center. NASA TM-88192, 1986.
7. Rossow, V. J.; Schmidt, G. I.; et al.: Experimental Study of Flow Deflectors Designed to Alleviate Ground Winds by Exhaust of 80- by 120- Foot Wind Tunnel. NASA TM-88195, 1986.
8. Wallis, R. A.: Wind Tunnel Tests on a Series of Circular Arc Plate Aerofoils. Note 74, Aeronautical Research Laboratories, Melbourne, Australia, 1946.
9. Horlock, J. H.: Axial Flow Compressor, Fluid Mechanics and Thermodynamics, Butterworths Scientific Publications, London, 1958.
10. Ross, James C.: Prediction of Vortex-Induced Loads on Wind-Tunnel Turning Vanes. NASA TM-86678, 1985.
11. Hoerner, Sighard F.: Fluid Dynamic Drag. Midland Park, New Jersey, 1965.
12. Maskew, B.: A Computer Program for Calculating the Non-Linear Aerodynamic Characteristics of Arbitrary Configuration. NASA CR-4023, 1984.
13. Hinze, J. O.: Turbulence. McGraw-Hill Book Company, 1959.
14. Equations, Tables, and Charts for Compressible Flow. NACA Report 1135, 1953.

15. Sachs, Peter: Wind Forces in Engineering. Pergamon Press, 1977.
16. Wick, Bradford H.: Study of the Subsonic Forces and Moments on an Inclined Plate of Infinite Span. NACA TN-3221, 1954.
17. Eckert, William T.; Mort, Kenneth W.; and Jope, Jean: Aerodynamic Design Guidelines and Computer Program for Estimation of Subsonic Wind Tunnel Performance. NASA TN D-8243, 1976.
18. Wieghardt, K. E.: On the Resistance of Screens. Aeronautical Quarterly, Vol. IV, Feb. 1953.
19. Schubauer, G. B.; Spangenberg, W. G.; and Klebanoff, P. S.: Aerodynamic Characteristics of Damping Screens. NACA TN-2001, 1950.

TABLE 1.- SPATIALLY AVERAGED FLOW CONDITION AT VANE SETS

40 X 80 TEST SECTION	40 X 60 MODE							
	VANE SET 1	VANE SET 2	VANE SET 3	VANE SET 4	VANE SET 5	VANE SET 6	VANE SET 8	
VELOCITY AT 0° ONSET , ft/sec	168.56	185.50	185.50	158.57	158.57	58.55	59.23	
DYNAMIC PRESSURE , lb/ft ²	32.28	39.07	39.07	28.50	28.50	4.02	3.33	
DENSITY , slug/ft ³	0.002272	0.002271	0.002271	0.002267	0.002267	0.002347	0.002347	
STATIC TEMPERATURE , °F	70	70	70	70	70	70	70	
STATIC PRESSURE , lb/ft ²	2066.56	2065.80	2061.80	2061.80	2061.80	2134.80	2134.80	
AREA PERPENDICULAR TO THE TUNNEL CENTERLINE , ft ²	2755	7456	---	---	8798	22856	22856	
WT. RATE OF FLOW , lb/sec	91944	101138	101138	---	101138	101138	91944	
AIR EXCHANGE RATE , %	---	10	10	10	10	10	---	
VANE FRONTAL AREA , ft ²	10544	10544	---	---	9689	32323	32323	

80 X 120 TEST SECTION	80 X 120 MODE					
	VANE SET 4	VANE SET 5	VANE SET 6	VANE SET 7		
VELOCITY AT 0° ONSET , ft/sec	190.07	178.67	67.83	62.78		
DYNAMIC PRESSURE , lb/ft ²	41.93	36.92	5.48	4.70		
DENSITY , slug/ft ³	0.002321	0.002313	0.002384	0.002385		
STATIC TEMPERATURE , °F	60	60	60	60		
STATIC PRESSURE , lb/ft ²	2071.50	2064.30	2127.80	2128.20		
AREA PERPENDICULAR TO THE TUNNEL CENTERLINE , ft ²	8378	8943	22,856	24690		
WT. RATE OF FLOW , lb/sec	119007	119007	119007	119007		
VANE FRONTAL AREA , ft ²	---	9481	32323	21876		
BOUNDARY LAYER DISPLACE- MENT THICKNESS , ft	0.5	0.5	0.5	---		

TABLE 2.- VANE SET 1 MAXIMUM HORIZONTAL AND VERTICAL VELOCITY PROFILE

FINAL 3-D Q/QAVE INTEGRATION =

1.104638

 MAXIMUM HORIZONTAL VELOCITY PROFILE DATA

DIST FROM INNER WALL	Q-VALUE IN.	V/VAVG ITER 1	(V/VAVG)**2 ITER 1	V/VAVG FINAL	V/VMAX FINAL	(V/VAVG)**2 FINAL
0.000	0.000	0.000000	0.000000	0.000000	0.000000	0.000000
0.006	1.560	0.782138	0.611739	0.738061	0.530171	0.544735
0.064	3.035	1.090938	1.190146	1.029460	0.739491	1.059789
0.112	4.625	1.346718	1.813650	1.270826	0.912871	1.614999
0.153	5.315	1.443685	2.084226	1.362329	0.978600	1.855939
0.194	5.490	1.467260	2.152851	1.384575	0.994580	1.917047
0.329	5.490	1.467260	2.152851	1.384575	0.994580	1.917047
0.364	5.350	1.448431	2.097951	1.366807	0.981817	1.868161
0.398	4.900	1.386178	1.921488	1.308062	0.939619	1.711026
0.479	3.035	1.090938	1.190146	1.029460	0.739491	1.059789
0.504	2.350	0.959964	0.921530	0.905866	0.650710	0.820594
0.519	2.400	0.970122	0.941137	0.915453	0.657596	0.838054
0.539	2.990	1.082820	1.172500	1.021800	0.733988	1.044075
0.653	5.335	1.446399	2.092069	1.364889	0.980439	1.862923
0.672	5.500	1.468596	2.156773	1.385835	0.995485	1.920539
0.698	5.540	1.473926	2.172458	1.390866	0.999099	1.934507
0.713	5.550	1.475256	2.176379	1.392120	1.000000	1.937999
0.798	5.450	1.461905	2.137166	1.379522	0.990950	1.903080
0.847	5.140	1.419719	2.015602	1.339713	0.962355	1.794832
0.899	4.240	1.289448	1.662675	1.216783	0.874050	1.480561
0.930	3.225	1.124568	1.264653	1.061195	0.762287	1.126134
0.967	1.965	0.877813	0.770556	0.828346	0.595024	0.686156
0.984	1.260	0.702920	0.494097	0.663308	0.476473	0.439978
1.000	0.000	0.000000	0.000000	0.000000	0.000000	0.000000

 MAXIMUM VERTICAL VELOCITY PROFILE DATA

DIST FROM FLOOR	Q-VALUE INCHES	V/VAVG ITER 1	V/VAVG FINAL	V/VMAX FINAL
0.000	0.000	0.000000	0.000000	0.000000
0.013	0.775	0.557081	0.525688	0.377617
0.125	2.475	0.995532	0.939430	0.674820
0.225	4.255	1.305321	1.231762	0.884810
0.316	5.125	1.432565	1.351836	0.971062
0.325	5.365	1.465725	1.383126	0.993539
0.471	5.435	1.475256	1.392120	1.000000
0.604	5.435	1.475256	1.392120	1.000000
0.694	5.160	1.437449	1.356444	0.974373
0.788	4.025	1.269552	1.198009	0.860564
0.863	2.775	1.054142	0.994737	0.714549
0.944	2.000	0.894916	0.844485	0.606618
0.991	1.275	0.714534	0.674267	0.484346
1.000	0.000	0.000000	0.000000	0.000000

TABLE 3.- VANE SET 2 MAXIMUM HORIZONTAL AND VERTICAL VELOCITY PROFILE

FINAL 3-D Q/QAVE INTEGRATION =

1.049690

 MAXIMUM HORIZONTAL VELOCITY PROFILE DATA

DIST FROM INNER WALL	Q-VALUE IN.	V/VAVG ITER 1	(V/VAVG)**2 ITER 1	V/VAVG FINAL	V/VMAX FINAL	(V/VAVG)**2 FINAL
0.000	0.000	0.000000	0.000000	0.000000	0.000000	0.000000
0.008	2.000	0.820689	0.673530	0.879567	0.673435	0.773639
0.039	2.625	0.940217	0.884009	1.007671	0.771517	1.015401
0.060	2.725	0.957959	0.917685	1.026685	0.786075	1.054083
0.085	2.385	0.896206	0.803185	0.960502	0.735402	0.922565
0.105	1.900	0.799909	0.639854	0.857296	0.656383	0.734957
0.124	2.165	0.853871	0.729096	0.915131	0.700664	0.837464
0.153	3.275	1.050193	1.102906	1.125537	0.861760	1.266834
0.201	3.930	1.150429	1.323487	1.232964	0.944011	1.520200
0.273	4.400	1.217278	1.481767	1.304609	0.998866	1.702006
0.312	4.410	1.218661	1.485134	1.306091	1.000000	1.705874
0.372	4.265	1.198459	1.436303	1.284440	0.983423	1.649785
0.420	3.850	1.138660	1.296546	1.220350	0.934353	1.489255
0.475	3.090	1.020100	1.040604	1.093285	0.837066	1.195272
0.514	2.885	0.985681	0.971567	1.056397	0.808823	1.115974
0.554	2.885	0.985681	0.971567	1.056397	0.808823	1.115974
0.691	4.120	1.177910	1.387472	1.262417	0.966561	1.593696
0.736	4.260	1.197756	1.434620	1.283687	0.982846	1.647851
0.784	4.250	1.196349	1.431252	1.282179	0.981692	1.643983
0.938	3.525	1.089540	1.187097	1.167707	0.894047	1.363539
0.992	2.100	0.840956	0.707207	0.901288	0.690066	0.812321
1.000	0.000	0.000000	0.000000	0.000000	0.000000	0.000000

 MAXIMUM VERTICAL VELOCITY PROFILE DATA

DIST FROM FLOOR	Q-VALUE INCHES	V/VAVG ITER 1	V/VAVG FINAL	V/VMAX FINAL
0.000	0.000	0.000000	0.000000	0.000000
0.015	1.515	0.717134	0.768583	0.588460
0.075	2.675	0.952918	1.021284	0.781939
0.113	2.925	0.996453	1.067941	0.817662
0.204	3.425	1.078261	1.155619	0.884792
0.263	3.875	1.146911	1.229194	0.941124
0.313	4.085	1.177578	1.262061	0.966289
0.375	4.340	1.213776	1.300856	0.995992
0.438	4.375	1.218661	1.306091	1.000000
0.500	4.275	1.204653	1.291078	0.988505
0.550	4.210	1.195460	1.281225	0.980962
0.619	3.925	1.154287	1.237098	0.947176
0.688	3.675	1.116921	1.197052	0.916515
0.731	3.425	1.078261	1.155619	0.884792
0.781	3.100	1.025828	1.099424	0.841767
0.838	2.825	0.979271	1.049527	0.803563
0.888	2.565	0.933120	1.000065	0.765693
0.963	2.435	0.909166	0.974392	0.746037
0.988	1.925	0.808368	0.866363	0.663325
1.000	0.000	0.000000	0.000000	0.000000

TABLE 4.- VANE SET 5 MAXIMUM HORIZONTAL AND VERTICAL VELOCITY PROFILE
40 x 80 MODE

FINAL 3-D Q/QAVE INTEGRATION =

1.051200

MAXIMUM HORIZONTAL VELOCITY PROFILE DATA

DIST FROM INNER WALL IN.	Q-VALUE	V/VAVG ITER 1	(V/VAVG)**2 ITER 1	V/VAVG FINAL	V/VMAX FINAL	(V/VAVG)**2 FINAL
0.000	0.000	0.000000	0.000000	0.000000	0.000000	0.000000
0.008	1.700	0.880071	0.774525	0.834675	0.648685	0.696683
0.019	1.900	0.930400	0.865645	0.882409	0.685782	0.778646
0.064	2.200	1.001162	1.002326	0.949521	0.737939	0.901590
0.102	2.240	1.010223	1.020550	0.958114	0.744618	0.917982
0.129	2.465	1.059746	1.123061	1.005082	0.781120	1.010190
0.182	3.445	1.252817	1.569551	1.188195	0.923430	1.411808
0.218	3.815	1.318380	1.738125	1.250376	0.971755	1.563439
0.312	4.040	1.356700	1.840635	1.286719	1.000000	1.655647
0.348	3.990	1.348278	1.817855	1.278732	0.993793	1.635156
0.441	3.365	1.238185	1.533103	1.174318	0.912645	1.379023
0.448	3.195	1.206504	1.455651	1.144270	0.889293	1.309355
0.486	2.990	1.167156	1.362252	1.106952	0.860290	1.225343
0.515	2.790	1.127445	1.271132	1.069289	0.831020	1.143380
0.548	2.790	1.127445	1.271132	1.069289	0.831020	1.143380
0.612	3.140	1.196074	1.430592	1.134379	0.881605	1.286815
0.720	3.810	1.317515	1.735846	1.249556	0.971118	1.561390
0.758	3.860	1.326132	1.758626	1.257728	0.977469	1.581880
0.803	3.750	1.307100	1.708510	1.239678	0.963441	1.536801
0.850	3.750	1.307100	1.708510	1.239678	0.963441	1.536801
0.864	3.490	1.260973	1.590053	1.195930	0.929442	1.430249
0.947	3.190	1.205559	1.453373	1.143374	0.888597	1.307305
0.977	2.690	1.107055	1.225571	1.049952	0.815991	1.102399
0.986	2.400	1.045680	1.093447	0.991742	0.770753	0.983553
1.000	0.000	0.000000	0.000000	0.000000	0.000000	0.000000

MAXIMUM VERTICAL VELOCITY PROFILE DATA

DIST FROM FLOOR	Q-VALUE INCHES	V/VAVG ITER 1	V/VAVG FINAL	V/VMAX FINAL
0.000	0.000	0.000000	0.000000	0.000000
0.006	1.090	0.713590	0.676782	0.525975
0.021	1.505	0.838502	0.795251	0.618045
0.129	2.765	1.136536	1.077912	0.837721
0.306	3.935	1.355839	1.285903	0.999365
0.376	3.940	1.356700	1.286719	1.000000
0.447	3.825	1.336754	1.267802	0.985298
0.506	3.815	1.335005	1.266144	0.984009
0.527	3.750	1.323583	1.255311	0.975590
0.600	3.835	1.338500	1.269458	0.986585
0.741	3.340	1.249134	1.184701	0.920715
0.800	2.990	1.181874	1.120911	0.871139
0.839	2.800	1.143707	1.084713	0.843006
0.939	1.950	0.954450	0.905218	0.703508
0.965	1.950	0.954450	0.905218	0.703508
0.976	1.790	0.914455	0.867286	0.674029
0.988	1.240	0.761108	0.721849	0.561000
1.000	0.000	0.000000	0.000000	0.000000

TABLE 5.- VANE SET 6 MAXIMUM HORIZONTAL AND VERTICAL VELOCITY PROFILE

FINAL 3-D Q/QAVE INTEGRATION =

1.063957

 MAXIMUM HORIZONTAL VELOCITY PROFILE DATA

DIST FROM INNER WALL	Q-VALUE IN.	V/VAVG ITER 1	(V/VAVG)**2 ITER 1	V/VAVG FINAL	V/VMAX FINAL	(V/VAVG)**2 FINAL
0.000	0.000	0.000000	0.000000	0.000000	0.000000	0.000000
0.027	0.900	1.205176	1.452450	1.249061	0.894427	1.560153
0.054	0.980	1.257600	1.581557	1.303393	0.933334	1.698833
0.109	0.750	1.100170	1.210375	1.140231	0.816497	1.300127
0.163	0.760	1.107481	1.226513	1.147808	0.821922	1.317462
0.217	0.720	1.077942	1.161960	1.117194	0.800000	1.248122
0.272	0.620	1.000288	1.000577	1.036712	0.742369	1.074772
0.326	0.570	0.959106	0.919885	0.994030	0.711805	0.988097
0.380	0.560	0.950656	0.903747	0.985272	0.705534	0.970762
0.435	0.580	0.967483	0.936023	1.002712	0.718022	1.005432
0.489	0.720	1.077942	1.161960	1.117194	0.800000	1.248122
0.543	0.790	1.129127	1.274928	1.170242	0.837987	1.369467
0.598	0.800	1.136251	1.291067	1.177626	0.843274	1.386802
0.652	0.760	1.107481	1.226513	1.147808	0.821922	1.317462
0.707	0.700	1.062866	1.129683	1.101568	0.788811	1.213452
0.761	0.700	1.062866	1.129683	1.101568	0.788811	1.213452
0.815	0.820	1.150367	1.323343	1.192255	0.853750	1.421472
0.870	1.000	1.270367	1.613833	1.316625	0.942809	1.733503
0.924	1.020	1.283008	1.646110	1.329727	0.952191	1.768173
0.978	1.125	1.347428	1.815562	1.396492	1.000000	1.950190
1.000	0.000	0.000000	0.000000	0.000000	0.000000	0.000000

 MAXIMUM VERTICAL VELOCITY PROFILE DATA

DIST FROM FLOOR	Q-VALUE INCHES	V/VAVG ITER 1	V/VAVG FINAL	V/VMAX FINAL
0.000	0.000	0.000000	0.000000	0.000000
0.032	0.850	1.242267	1.287502	0.921954
0.064	0.900	1.278282	1.324829	0.948683
0.127	0.780	1.190016	1.233348	0.883176
0.191	0.790	1.197620	1.241229	0.888820
0.255	0.950	1.313310	1.361132	0.974680
0.318	0.780	1.190016	1.233348	0.883176
0.382	0.650	1.086331	1.125888	0.806226
0.446	0.600	1.043713	1.081718	0.774597
0.510	0.670	1.102917	1.143078	0.818535
0.573	0.850	1.242267	1.287502	0.921954
0.637	1.000	1.347428	1.396492	1.000000
0.701	0.960	1.320204	1.368277	0.979796
0.764	0.890	1.271161	1.317448	0.943398
0.828	0.900	1.278282	1.324829	0.948683
0.892	0.950	1.313310	1.361132	0.974680
0.955	0.900	1.278282	1.324829	0.948683
0.987	0.770	1.182363	1.225417	0.877497
1.000	0.000	0.000000	0.000000	0.000000

TABLE 6.- VANE SET 8 MAXIMUM HORIZONTAL AND VERTICAL VELOCITY PROFILE

FINAL 3-D Q/QAVE INTEGRATION =

1.035916

 MAXIMUM HORIZONTAL VELOCITY PROFILE DATA

DIST FROM INNER WALL	Q-VALUE IN.	V/VAVG ITER 1	(V/VAVG)**2 ITER 1	V/VAVG FINAL	V/VMAX FINAL	(V/VAVG)**2 FINAL
0.000	0.000	0.000000	0.000000	0.000000	0.000000	0.000000
0.003	0.600	1.073337	1.152052	1.076838	0.866025	1.159579
0.012	0.790	1.231612	1.516868	1.235629	0.993730	1.526779
0.053	0.700	1.159336	1.344060	1.163118	0.935414	1.352842
0.108	0.700	1.159336	1.344060	1.163118	0.935414	1.352842
0.151	0.740	1.192000	1.420864	1.195888	0.961769	1.430148
0.225	0.650	1.117164	1.248056	1.120808	0.901388	1.256211
0.367	0.695	1.155188	1.334460	1.158956	0.932068	1.343179
0.436	0.750	1.200027	1.440064	1.203941	0.968246	1.449474
0.489	0.760	1.208001	1.459266	1.211941	0.974679	1.468800
0.534	0.800	1.239383	1.536069	1.243425	1.000000	1.546106
0.605	0.750	1.200027	1.440064	1.203941	0.968246	1.449474
0.689	0.700	1.159336	1.344060	1.163118	0.935414	1.352842
0.807	0.500	0.979818	0.960043	0.983014	0.790569	0.966316
0.881	0.350	0.819774	0.672030	0.822448	0.661438	0.676421
0.910	0.350	0.819774	0.672030	0.822448	0.661438	0.676421
0.996	0.225	0.657282	0.432019	0.659426	0.530330	0.434842
1.000	0.000	0.000000	0.000000	0.000000	0.000000	0.000000

 MAXIMUM VERTICAL VELOCITY PROFILE DATA

DIST FROM FLOOR	Q-VALUE INCHES	V/VAVG ITER 1	V/VAVG FINAL	V/VMAX FINAL
0.000	0.000	0.000000	0.000000	0.000000
0.005	0.320	0.783854	0.786411	0.632456
0.059	0.575	1.050738	1.054165	0.847791
0.141	0.625	1.095470	1.099043	0.883884
0.168	0.625	1.095470	1.099043	0.883884
0.303	0.775	1.219863	1.223842	0.984251
0.359	0.800	1.239383	1.243425	1.000000
0.680	0.715	1.171692	1.175514	0.945383
0.713	0.675	1.138445	1.142159	0.918559
0.797	0.710	1.167588	1.171396	0.942072
0.965	0.575	1.050738	1.054165	0.847791
0.995	0.425	0.903347	0.906294	0.728869
1.000	0.000	0.000000	0.000000	0.000000

TABLE 7.- VANE SETS 1 AND 2 LOAD CASES AND INPUTS

VANE SET	LOAD	ϵ_1 deg	ϵ_2 deg	β_1 deg	β_2 deg	F_3	A, ft^2	η	$(\Delta P/q)_s$	$(C_p)_{sp}$	A_{sp}, ft^2	C_m	q_{ave} lb/ft ²	ρ slugs/ft ³
1	Global design and local	3.0	0.0	48.0	-45.0	1.105	10544	0.078	0.04	0.025	4612	-0.19	36.0	0.002272
	Global design	3.0	4.0	48.0	-41.0			0.078				-0.19	36.0	
	Global design	-3.0	0.0	42.0	-45.0			0.074				-0.31	29.2	
	Global design and local	-3.0	-4.0	42.0	-49.0			0.074				-0.31	29.2	
2	Global operating	1.0	0.0	46.0	45.0	1.105	10544	0.076	0.04	0.025	4612	-0.23	32.3	0.002272
	Global design with 10% air exchange	1.0	-2.0	46.0	-47.0	1.05	10544	0.076	0.04	0.025	4612	-0.23	40.5	0.002271
		1.0	2.0	46.0	-43.0			0.076				-0.23	40.5	
		-1.0	-2.0	44.0	-47.0			0.075				-0.27	37.8	
		-1.0	2.0	44.0	-43.0			0.075				-0.27	37.8	
	Global operating	0.0	0.0	45.0	-45.0	1.050	10544	0.075	0.04	0.025	4612	-0.25	39.1	0.002271

TABLE 8.- VANE SET 3 LOAD CASES AND INPUTS

40 X 80 MODE											
LOCAL LOAD	ϵ_1 deg	ϵ_2 deg	β_1 deg	β_2 deg	η	$(\Delta P/q)s$	c_m	VANE			q_{ave} lb/ft ²
								c, ft	P, ft	b, ft	
Design vane 3 I	3	0	-42	-45	0.065	0.04	-0.019	20.2	19.5	68.27	35.4
Operating vane 3 I	-3		-48				0.019				43.6
	0		-45				0.000				39.1

NOTE: LOADS CALCULATED WITH 10% AIR EXCHANGE IN 40 X 80 MODE

TABLE 9.- VANE SET 4 LOAD CASES AND INPUTS

80 X 120 MODE											
LOCAL LOAD	ϵ_1 deg	ϵ_2 deg	β_1 deg	β_2 deg	η	$(\Delta P/q)s$	C_m	VANE			Q_{ave} lb/ft ²
								c, ft	P, ft	b, ft	
Design vane 4 C	3	0	-42	-45	0.089	0.04	0.019	33.91	33.21	69.34	37.96
	5		-40				0.032				35.72
	10		-35				-0.116				31.24
Operating	0	0	-45	-45	0.089	0.04	0.000	33.91	33.21	69.34	41.93

NOTE: 1. FOR EACH CASE CONSIDERED, LOADS WERE CALCULATED FOR THE FOLLOWING:

- a. NO VORTEX OR JET EFFECT
- b. VORTEX EFFECT WITH THE VORTEX CENTER AT THE VANE MIDSPAN
- c. JET AND PROPELLER WAKE EFFECT WITH THE WAKE CENTER AT THE VANE MIDSPAN

2. FOR JET EFFECT, SEE FIGURE 19 FOR DYNAMIC PRESSURE PROFILE

TABLE 10. - VANE SET 5 LOAD CASES AND INPUTS

MOOE	LOAD	ε ₁ , deg	ε ₂ , deg	Splay angle deg	Splay Angle Extent %		β ₁ , deg	β ₂ , deg	A, ft ²	η	(ΔP/ρ) _s	(ε ₂ /ε ₁) _{sp}	A _{sp} , ft ²	α _m	VANE			F ₁	F ₂	F _s	q _{ave} lb/ft ²	P slug/ft ³
					START	END									c, ft	P, ft	d, ft					
40X80	Global design	3.00	1.28	-3.00	0.000	0.158	-22.6	-27.32	9689	0.105	0.04	0.025	2005	-0.12	6.67	3.43	75.4	1.224	1.291	1.051	27.2	0.002267
				-2.00	0.185	0.292		-26.32														
				-1.00	0.318	0.425		-25.32														
				0.00	0.452	0.559		-24.32														
				1.00	0.585	0.692		-23.32														
				2.00	0.719	0.826		-22.32														
	Global and local design	3.00	-2.72	3.00	0.852	1.000	1.000	-21.32	0.969	0.12	0.04	0.025	2005	-0.12	6.67	3.43	75.4	1.106	1.132	1.051	27.2	0.002267
					0.000	0.158	0.292	-31.32														
					0.185	0.292	0.425	-30.32														
					0.318	0.425	0.559	-29.32														
					0.452	0.559	0.692	-28.32														
					0.585	0.692	0.826	-27.32														
Global and local design	-3.00	0.50	-3.00	0.000	0.158	0.292	-28.6	-28.10	0.969	0.12	0.04	0.025	2005	-0.12	6.67	3.43	75.4	0.969	0.951	1.051	27.2	0.002267
				0.185	0.292	0.425		-27.10														
				0.318	0.425	0.559		-26.10														
				0.452	0.559	0.692		-25.10														
				0.585	0.692	0.826		-24.10														
				0.826	1.000	1.000		-23.10														
Global and local design	-3.00	-3.50	3.00	0.852	1.000	1.000	-22.10	-22.10	1.658	0.12	0.04	0.025	2005	-0.12	6.67	3.43	75.4	1.658	1.838	1.051	27.2	0.002267
				0.000	0.158	0.292		-32.10														
				0.185	0.292	0.425		-31.10														
				0.318	0.425	0.559		-30.10														
				0.452	0.559	0.692		-29.10														
				0.585	0.692	0.826		-28.10														

NOTE: q_{ave} VALUES AS SHOWN WITH NO JET OR PROPELLER WAKE EFFECT

TABLE 10.- CONTINUED

MODE	LOAD	ϵ_1 , deg	ϵ_2 , deg	Splay Angle Width From West Wall START	Splay Angle Extent % END	β_1 , deg	β_2 , deg	A, ft ²	η	$(\Delta P/q)_e$	$(c_p)_{sp}$	A_{sp} , ft ²	c_m	VANE			F ₁	F ₂	F ₃	Q_{ave} slug/ft ³	P slug/ft ³		
														c, ft	P, ft	b, ft							
40X80	Global operating	0.00	-1.00	0.000	0.158	-25.6	-29.60	9889	0.115	0.04	0.025	2005	-0.12	6.67	3.43	75.4	1.351	1.452	1.057	28.5	0.002267		
		-2.00	0.195	0.292	-28.60																		
		-1.00	0.318	0.425	-27.60																		
		0.00	0.452	0.559	-26.60																		
		1.00	0.585	0.692	-25.60																		
		2.00	0.719	0.826	-24.60																		
80X120	Global design	3.00	0.852	1.000	-23.60																		
		55.00	1.50	0.000	0.158	29.4	-27.05			0.273			0.036				1.001	0.974	1.00	43.3	0.002313		
		-2.00	0.195	0.292	-26.05																		
		-1.00	0.318	0.425	-25.05																		
		0.00	0.452	0.559	-24.05																		
		1.00	0.585	0.692	-23.05																		
Global and local design Global design	Global design	2.00	0.719	0.826	-22.05																		
		3.00	0.852	1.000	-21.05																		
		-3.00	0.000	0.158	-31.05																		
		-2.50	0.195	0.292	-30.05																		
		-1.00	0.318	0.425	-29.05																		
		0.00	0.452	0.559	-28.05																		
Global and local design Global design	Global design	1.00	0.585	0.692	-27.05																		
		2.00	0.719	0.826	-26.05																		
		3.00	0.852	1.000	-25.05																		
		45.00	2.50	0.000	0.158	19.40	-26.10																
		-2.00	0.195	0.292	-25.10																		
		-1.00	0.318	0.425	-24.10																		
Global and local design Global design	Global design	0.00	0.452	0.559	-23.10																		
		1.00	0.585	0.692	-22.10																		
		2.00	0.719	0.826	-21.10																		
		3.00	0.852	1.000	-20.10																		
		1.051																					
		36.9																					

NOTE: η and c_m VALUES AS SHOWN WITH NO JET OR PROPELLER WAKE EFFECT

TABLE 10.- CONCLUDED

MODE	LOAD	ϵ_1 , deg	ϵ_2 , deg	Splay angle deg	Splay Angle Extent %		β_1 , deg	β_2 , deg	A, ft ²	η	$(\Delta P/q)_s$	$(c_d)_{sp}$	A_{sp} , ft ²	c_m	VANE			F ₁	F ₂	F ₃	q_{ave} lb/ft ²	P slugs/ft ³			
					START	END									c, ft	P, ft	b, ft								
80 X 120	Global and Local design	45.00	-1.5	-3.00	0.000	0.158	19.4	-30.1	9689	0.205	0.04	0.025	2005	-0.038	6.67	3.43	75.4	1.002	1.027	1.00	36.9	0.002329			
	Global design			-2.00	0.185	0.292		-29.1																	
				-1.00	0.318	0.425		-28.1																	
				0.00	0.452	0.559		-27.1																	
	Global operating			1.00	0.585	0.692		-26.1																	
				2.00	0.719	0.826		-25.1																	
				3.00	0.852	1.000		-24.1																	
					0.5			-28.1																	
					-2.00	0.185	0.292		-27.1																
					-1.00	0.318	0.425		-26.1																
			0.00	0.452	0.559		-25.1																		
			1.00	0.585	0.692		-24.1																		
			2.00	0.719	0.826		-23.1																		
			3.00	0.852	1.000		-22.1																		

TABLE 11.- VANE SET 6 LOAD CASES AND INPUTS

MODE	LOAD	ϵ_1 , deg	ϵ_2 , deg	β_1 , deg	β_2 , deg	F ₃	A, ft ²	η	$(\Delta P/q)_s$	$(c_d)_{sp}$	A_{sp} , ft ²	c_m	VANE			F ₁	F ₂	F ₃	q_{ave} lb/ft ²	P slugs/ft ³
													c, ft	P, ft	b, ft					
40 X 80	Global design and local load	3.40	3.00	48.4	-42.00	1.064	32323	0.78	0.04	0.025	7518	-0.214	17.2	4.2	132.5				4.6	0.002347
		3.40	-3.00	48.4	-48.00			0.78				-0.214							4.6	
		-3.40	3.00	41.6	-42.00			0.93				-0.326							3.6	
		-3.40	-3.00	41.6	-48.00			0.93				-0.326							3.6	
80 X 120	Global operating	0.00	0.00	45.00	-45.00			0.85				-0.269							4.0	
		3.40	0.00	48.40	45.00			0.319				0.104							6.1	
			0.00	45.00	45.00															5.4

TABLE 12.- VANE SET 7 LOAD CASES AND INPUTS

LOAD	ϵ_1 , deg	ϵ_2 , deg	β_1 , deg	β_2 , deg	F_3	A , ft ²	η	$(\Delta P/q)_e$	$(c_d)_{ep}$	A_{sp} , ft ²	c_m^a	c , ft	q_{ave} lb/ft ²	P slugs/ft ³
Global design and operating	0	40	0	40	1	24690	1.73	0	0	0	-0.94	10.54	4.7	0.002384
Local design and operating	0	40	0	40	1	24690	1.73	0	0	0	-0.94	10.54	4.7	0.002384

a. PITCHING MOMENT ABOUT VANE HINGE LINE.

TABLE 13.- VANE SET 8 LOAD CASES AND INPUTS

LOAD	ϵ_1 , deg	ϵ_2 , deg	β_1 , deg	β_2 , deg	F_3	A , ft ²	η	$(\Delta P/q)_e$	$(c_d)_{ep}$	A_{sp} , ft ²	c_m	VANE		q_{ave} lb/ft ²	P slugs/ft ³	
												c , ft	P , ft			
Global design & local load	3.00	-0.8	48.00	-45.8	1.036	32323	0.124	0.04	0.025	7920	-0.305	3.00	1.5	132.5	3.70	0.002347
	3.00	-4.8	48.00	-49.8			0.124				-0.305				3.70	
	-3.00	-2.8	42.00	-47.8			0.176				-0.455				3.00	
	-3.00	-6.8	42.00	-51.8			0.176				-0.455				3.00	
Global operating	0.00	-3.8	45.00	-48.8			0.15				-0.38				3.3	

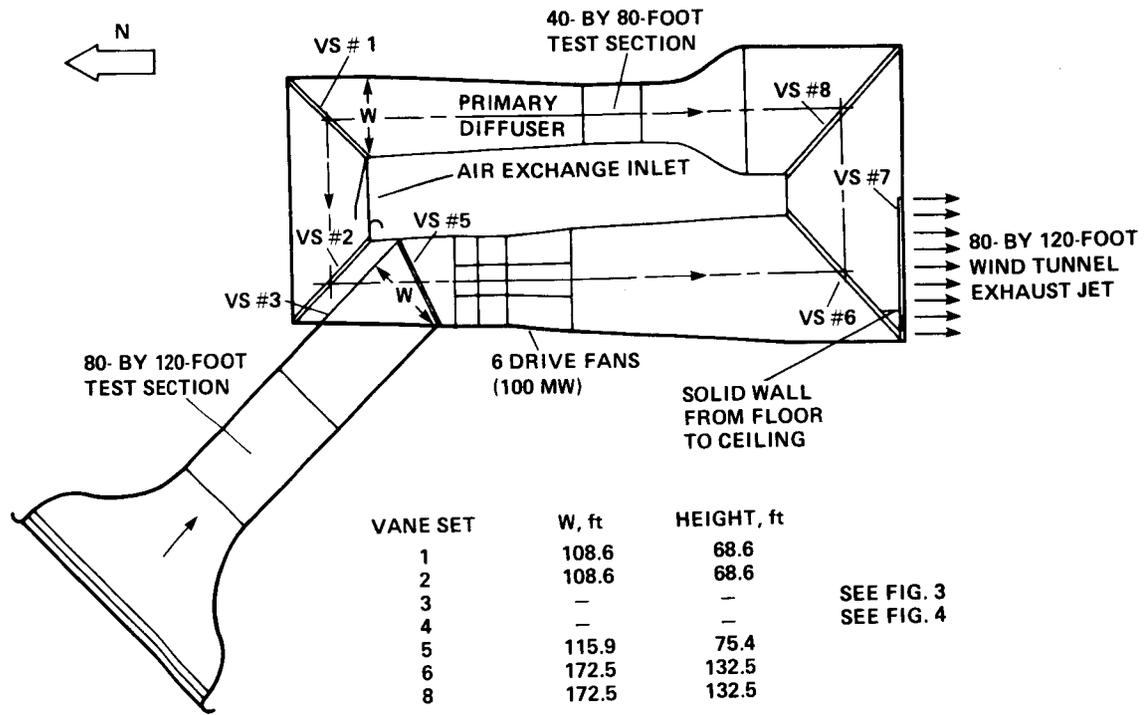
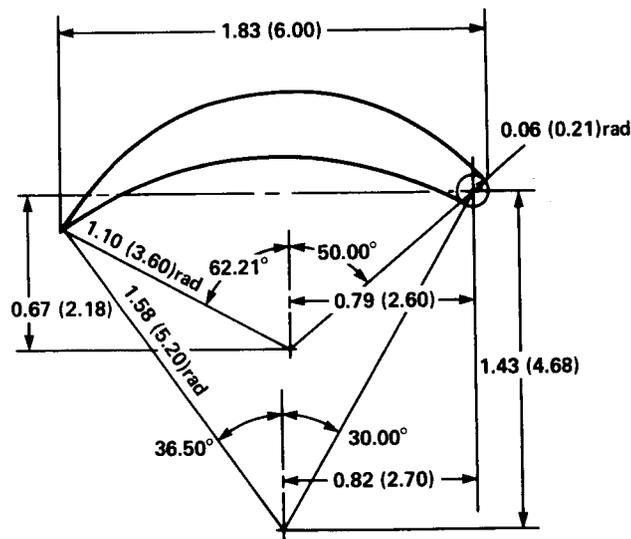
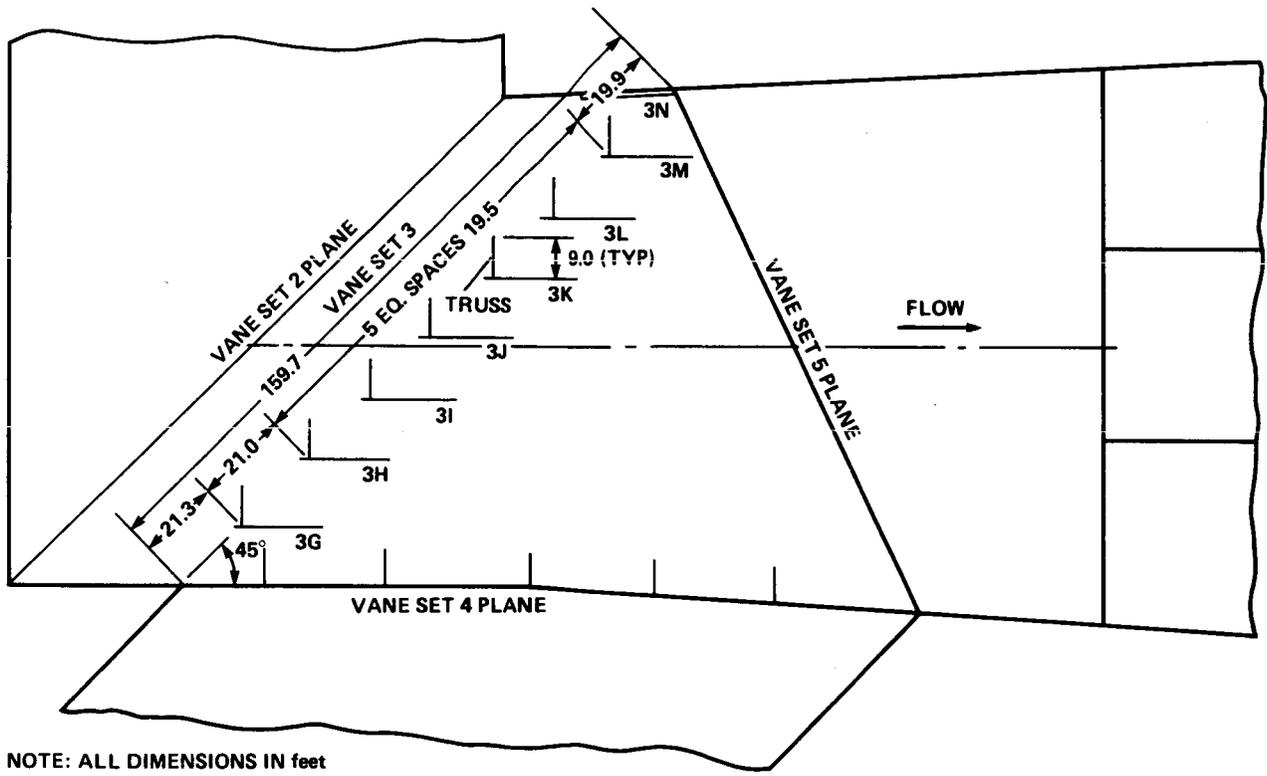

Figure 1.- Layout of the 40 x 80 and 80 x 120 circuits showing location of vane sets.



DETAIL A DIMENSIONS IN meters (feet)

Figure 2.- Details of 90° circular-arc turning vanes at vane sets 1 and 2.



(a) Plan view.

Figure 3.- Vane set 3 layout in 40 x 80 mode.

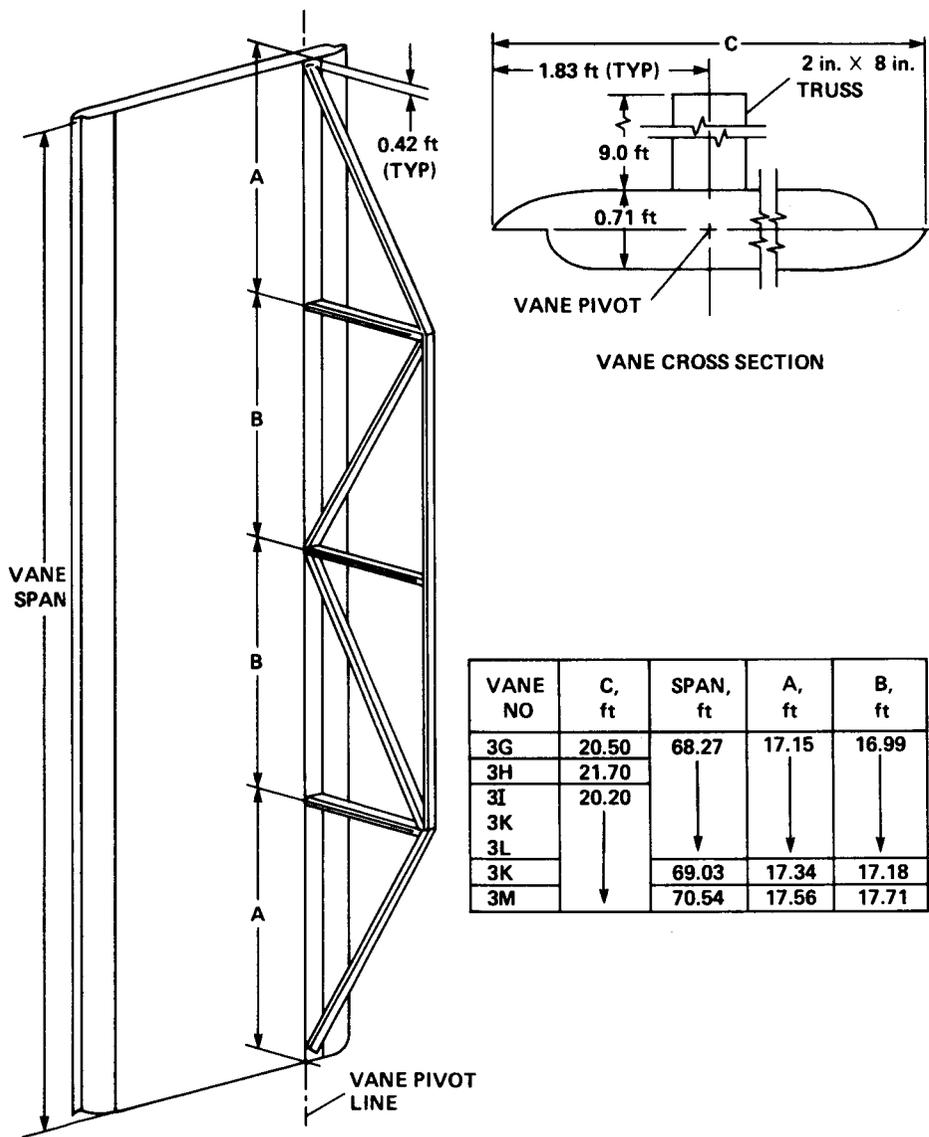

VANE NO	C, ft	SPAN, ft	A, ft	B, ft
3G	20.50	68.27	17.15	16.99
3H	21.70			
3I	20.20			
3K				
3L				
3K		69.03	17.34	17.18
3M		70.54	17.56	17.71

(b) Vane geometry.

Figure 3.- Concluded.

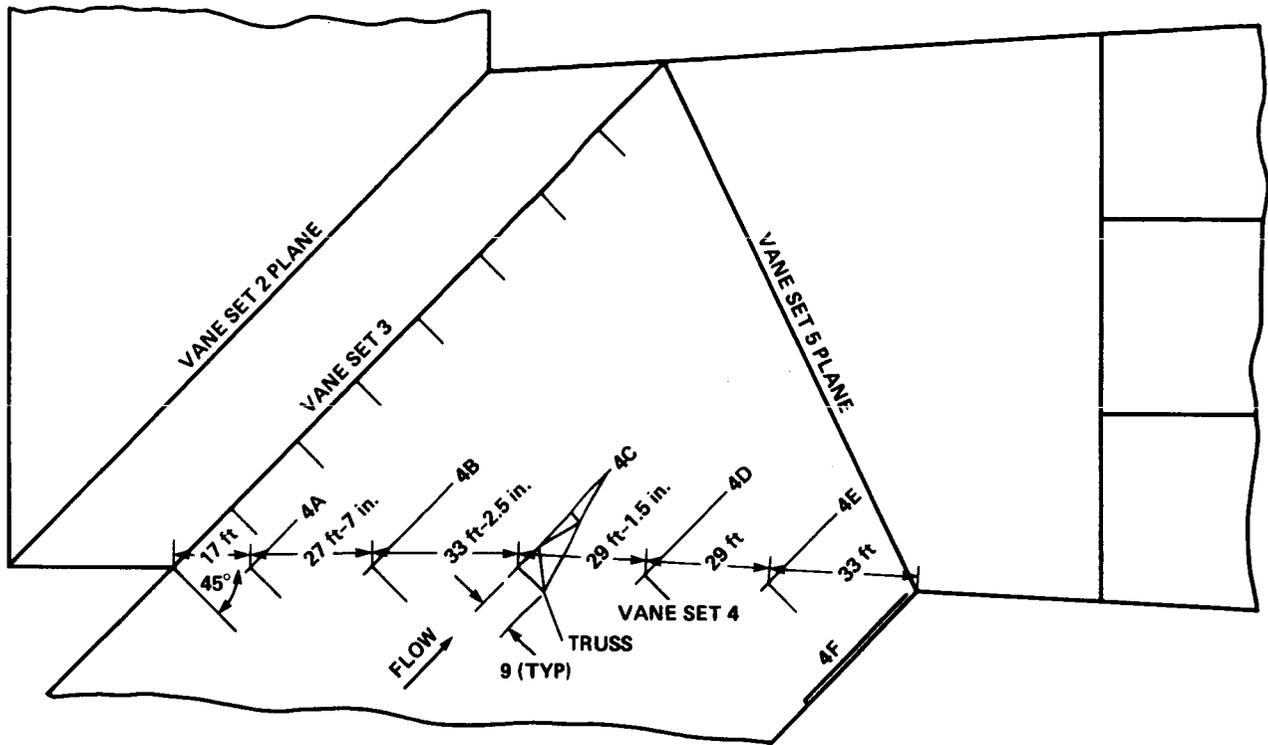

(a) Plan view.

Figure 4.- Vane set 4 layout and geometry.

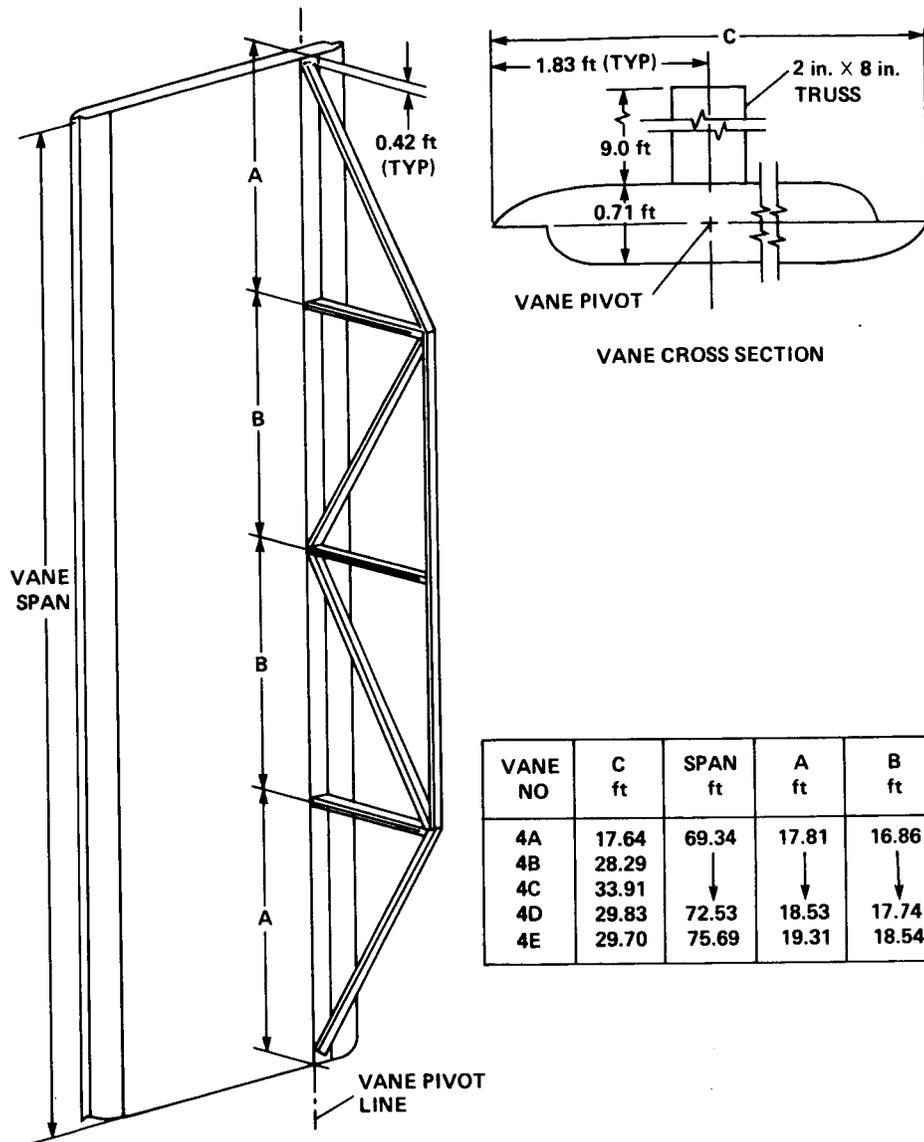

(b) Vane geometry.

Figure 4.- Continued.

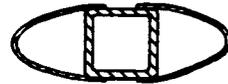
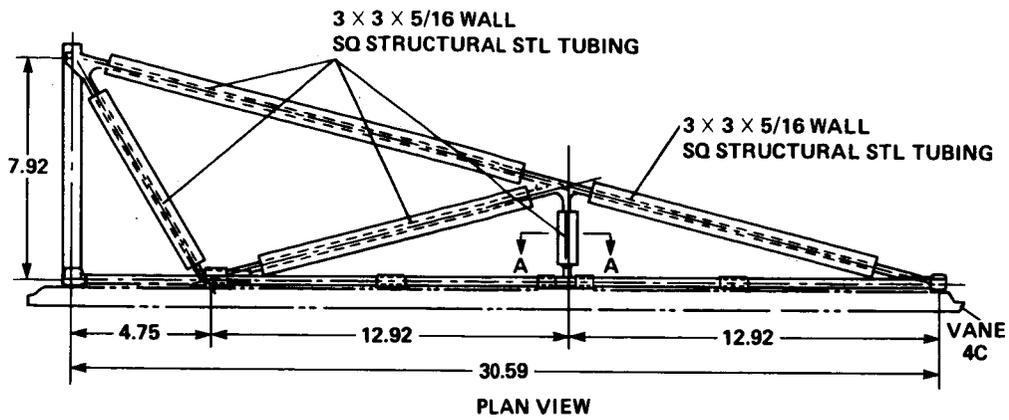

SECTION A-A TYP FOR 5 PLACES

NOTE: ALL DIMENSIONS IN FEET EXCEPT
TUBING DIMENSIONS WHICH ARE
IN INCHES

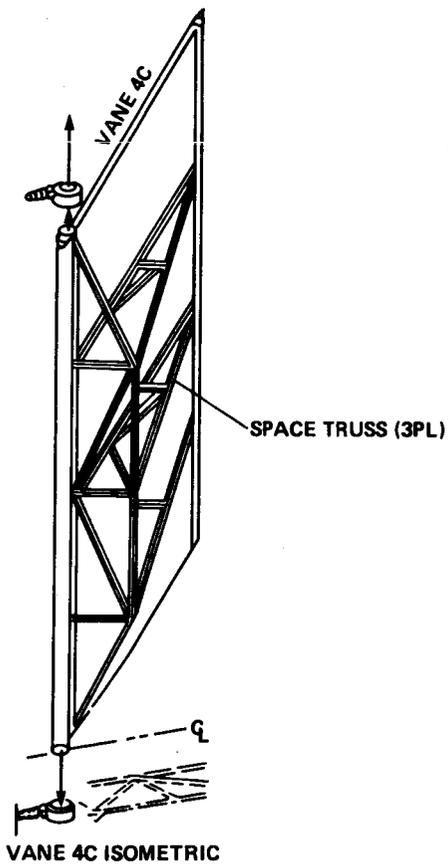

(c) Vane 4C space truss.

Figure 4.- Concluded.

VANE COORDINATES (C=6.67 FT)

X, %c	Y _u , %c	X, %c	Y _l , %c	SPLAY ANGLE B, DEG
0.000	0.751	100.000	-4.882	3
0.238	1.602	99.725	-4.757	2
0.776	2.441	99.387	-4.720	1
1.552	3.230	98.736	-4.582	0
2.516	3.981	96.758	-4.244	-1
3.630	4.682	93.816	-3.868	-2
4.870	5.333	90.248	-3.568	-3
6.184	5.921	88.445	-3.493	
7.586	6.472	86.330	-3.418	
9.051	6.948	82.261	-3.443	
10.541	7.399	78.155	-3.630	
12.056	7.824	74.124	-3.943	
13.583	8.200	70.218	-4.369	
15.135	8.563	66.462	-4.820	
16.700	8.921	62.857	-5.270	
18.240	9.201	59.377	-5.696	
19.754	9.515	55.972	-6.072	
21.240	9.816	52.629	-6.397	
22.700	10.091	49.337	-6.698	
24.135	10.342	46.082	-6.960	
25.541	10.579	42.852	-7.173	
26.921	10.800	39.609	-7.336	
28.280	11.005	36.355	-7.461	
29.621	11.192	33.075	-7.549	
30.940	11.362	29.757	-7.599	
32.240	11.515	26.427	-7.599	
33.521	11.652	23.060	-7.511	
34.780	11.772	19.655	-7.324	
36.021	11.875	16.212	-6.998	
37.240	11.962	14.484	-6.760	
38.440	12.032	12.769	-6.472	
39.621	12.085	11.042	-6.109	
40.780	12.121	9.339	-5.684	
41.921	12.142	7.662	-5.183	
43.040	12.148	6.059	-4.632	
44.135	12.139	4.532	-4.006	
45.200	12.115	3.155	-3.330	
46.240	12.077	1.965	-2.591	
47.251	12.025	1.027	-1.815	
48.230	11.960	0.376	-1.002	
49.180	11.882	-0.757	-0.138	
50.100	11.795	-1.882		

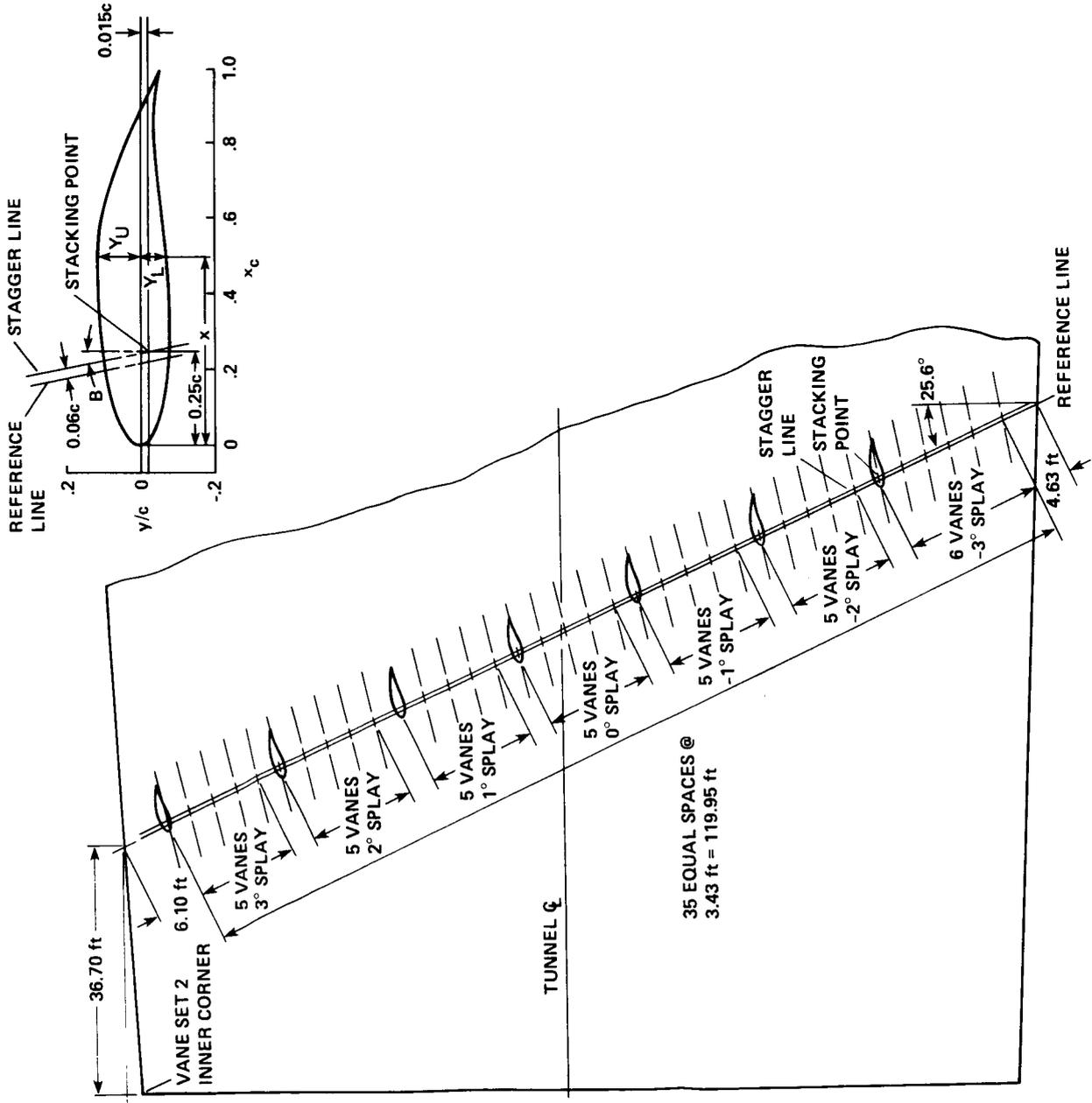
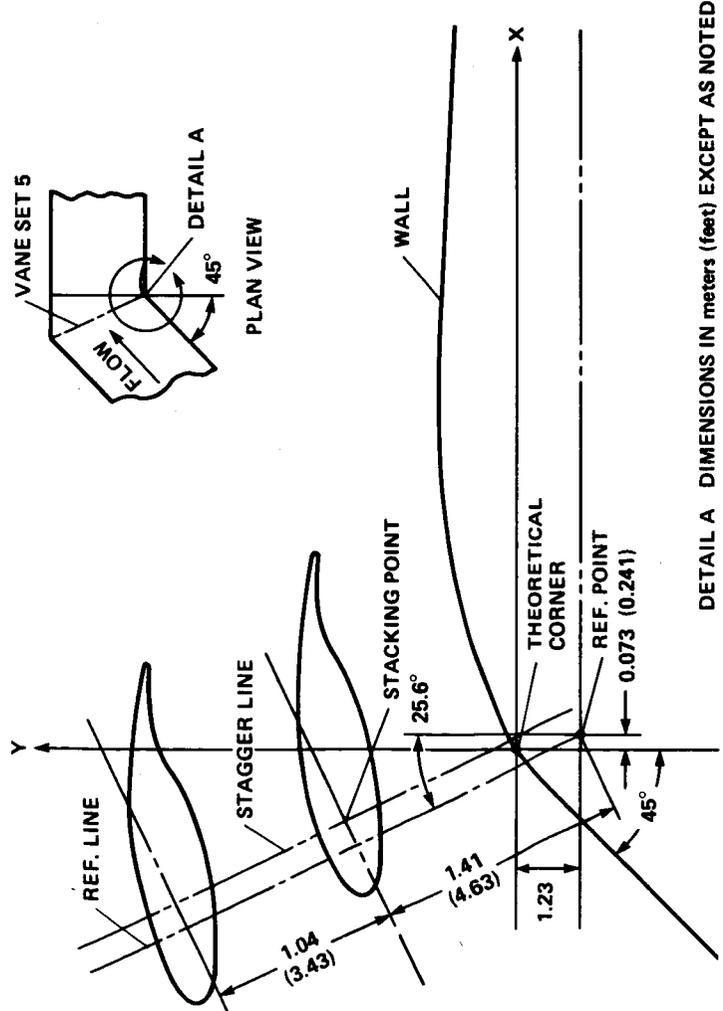

Figure 5.- Vane set 5 geometry.

TABLE OF OFFSETS FROM AERODYNAMIC SURFACE FROM THEORETICAL CORNER

M	FT	:	M	FT
0.000	0.000	:	0.000	0.000
0.049	0.160	:	0.024	0.080
0.098	0.320	:	0.047	0.153
0.144	0.473	:	0.069	0.227
0.191	0.627	:	0.089	0.293
0.236	0.773	:	0.108	0.353
0.280	0.920	:	0.126	0.413
0.323	1.060	:	0.142	0.467
0.366	1.200	:	0.158	0.520
0.408	1.340	:	0.175	0.573
0.449	1.473	:	0.189	0.620
0.490	1.607	:	0.201	0.660
0.528	1.733	:	0.215	0.707
0.567	1.860	:	0.226	0.740
0.606	1.987	:	0.238	0.780
0.644	2.113	:	0.248	0.813
0.660	2.167	:	0.203	0.667
0.260	0.853	:	0.717	2.353
0.268	0.880	:	0.790	2.593
0.287	0.940	:	0.860	2.820
0.303	0.993	:	0.929	3.047
0.317	1.040	:	0.996	3.267
0.331	1.087	:	1.063	3.487
0.343	1.127	:	1.128	3.700
0.354	1.160	:	1.191	3.907
0.362	1.187	:	1.254	4.113
0.370	1.213	:	1.317	4.320
0.378	1.240	:	1.378	4.520
0.384	1.260	:	1.439	4.720
0.390	1.280	:	1.500	4.920
0.394	1.293	:	1.559	5.113
0.398	1.307	:	1.617	5.307
0.402	1.320	:	1.737	5.700
0.406	1.333	:	1.853	6.080
0.410	1.347	:	1.971	6.467
0.410	1.347	:	2.117	6.947
0.408	1.340	:	2.355	7.727
0.404	1.327	:	2.457	8.060



DETAIL A DIMENSIONS IN METERS (FEET) EXCEPT AS NOTED

Figure 6.- Fairing located at vane set 5 corner.

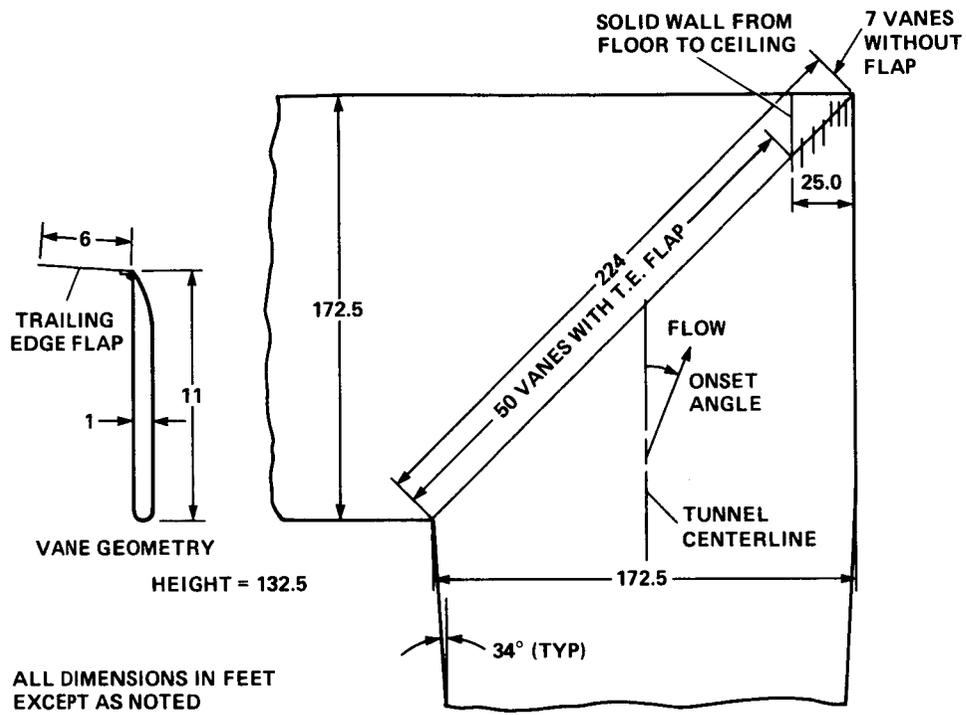

Figure 7.- Vane set 6 geometry.

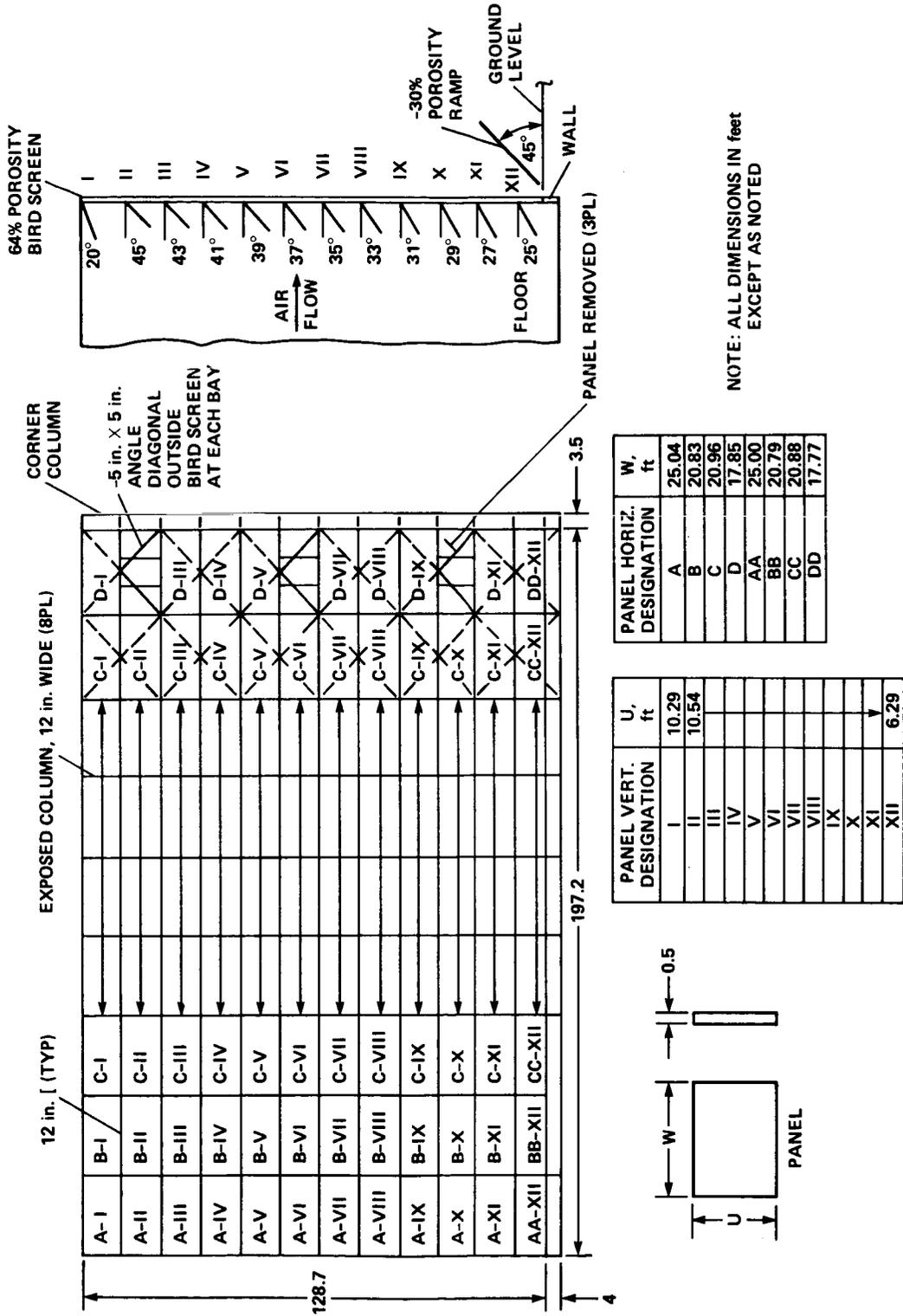
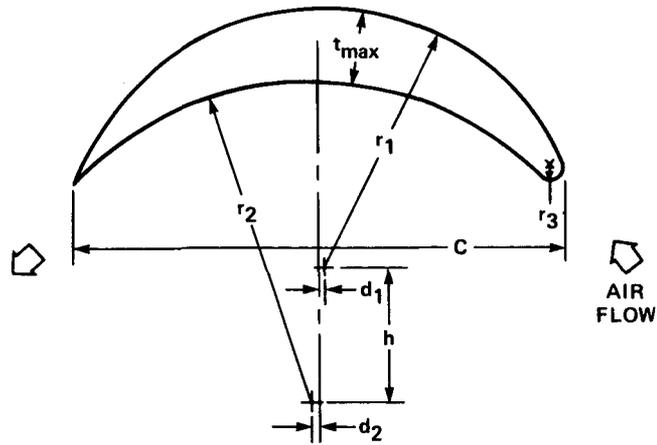

Figure 8.- Vane set 7 layout.



	c	h	r ₁	d ₁	r ₂	d ₂	r ₃	t _{max}
VANE SET 8	0.914 (3.00)	0.250 (0.82)	0.491 (1.61)	0.010 (0.03)	0.610 (2.00)	0.014 (0.05)	0.024 (0.08)	0.133 (0.44)

DIMENSIONS IN meters (feet)

Figure 9.- Details of 90° circular-arc turning vanes at vane set 8.

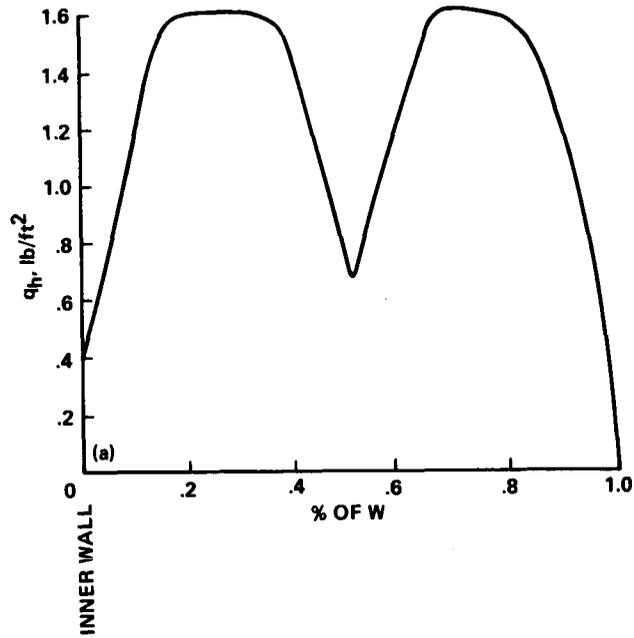

(a) Vane set 1 horizontal survey at centerline perpendicular to tunnel circuit centerline.

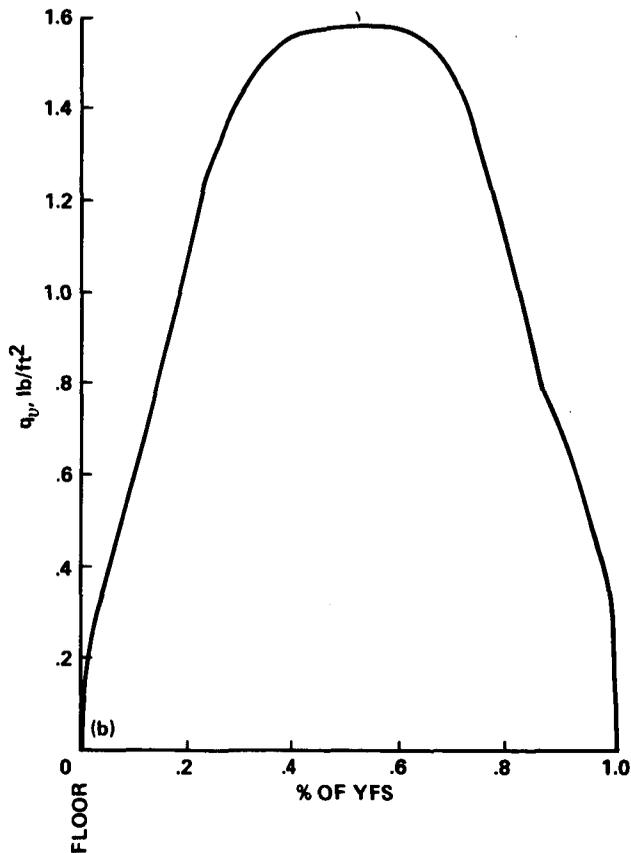

(b) Vertical survey, 0.27 W from inner wall.

Figure 10.- Dynamic pressure surveys in front of vane set 1: 1/50-scale 40 x 80 model, $q_{50ts} = 59.76 \text{ lb/ft}^2$, $m = 8.6\%$.

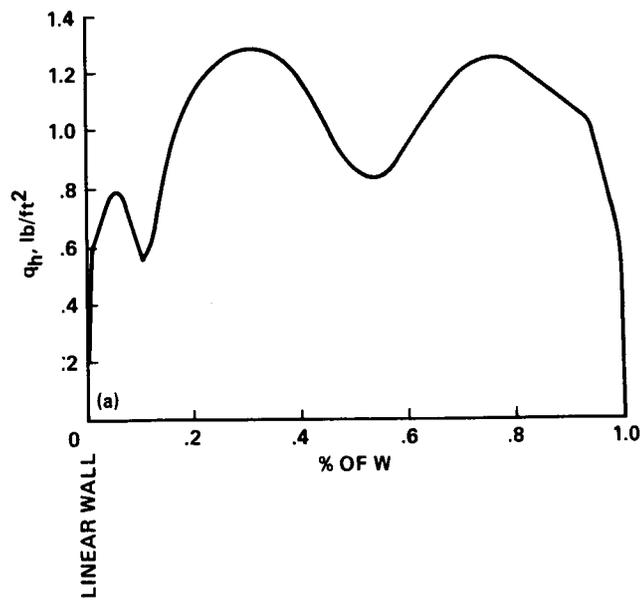

(a) Horizontal survey at centerline normal to the tunnel circuit centerline.

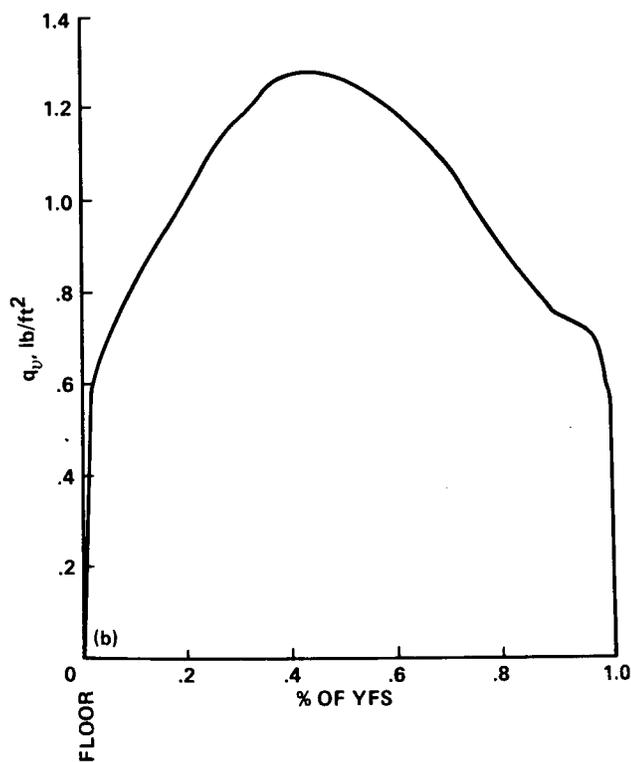

(b) Vertical survey, 0.27 W from outer wall.

Figure 11.- Dynamic pressure surveys in front of vane set 2: 1/50-scale 40 x 80 model, $q_{50ts} = 59.76 \text{ lb/ft}^2$, $m = 8.6\%$.

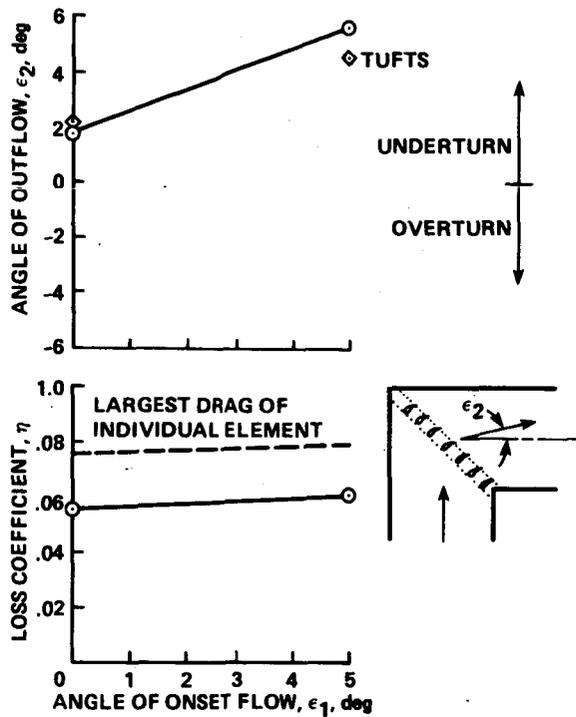
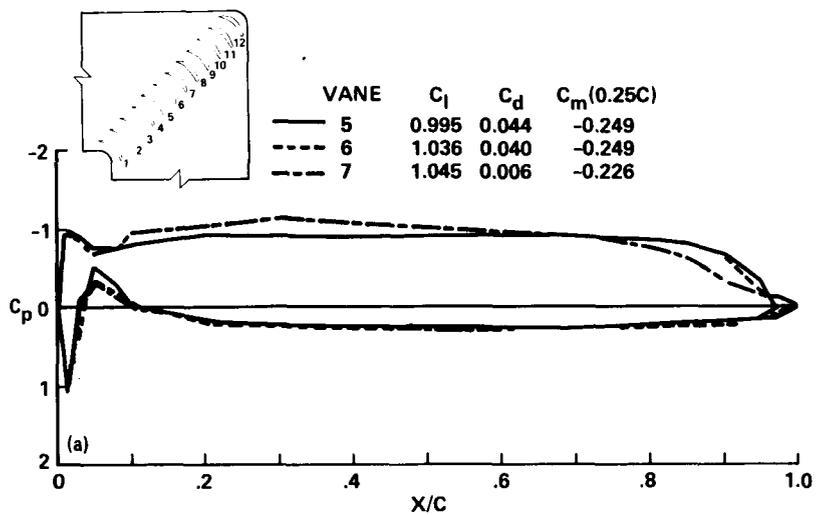
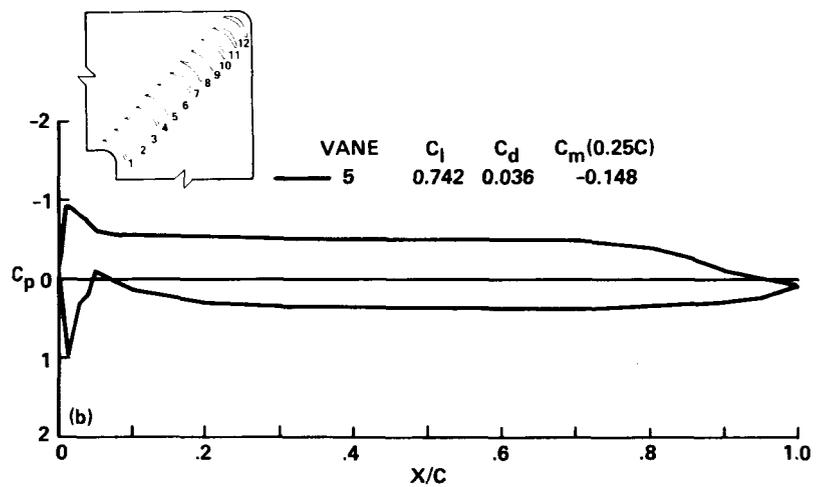

Figure 12.- Variation of loss coefficient η and angle of outflow with angle of onset for vane sets 1 and 2. "TUFTS" indicates observation of an average of 10 tufts on tuft wire.



(a) $\epsilon_1 = 0^\circ$.



(b) $\epsilon_1 = 5^\circ$.

Figure 13.- Chordwise pressure distribution of vane sets 1 and 2: Lewis Research Center design vane, 1/10-scale tester data.

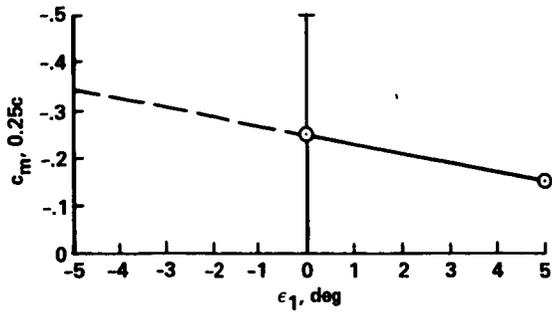

Figure 14.- Variation of c_m about $1/4 c$ with angle of onset; 1/10-scale tester data.

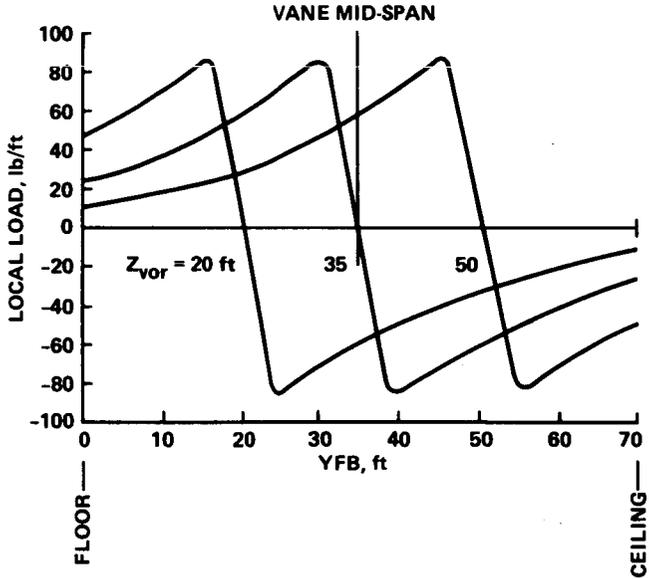
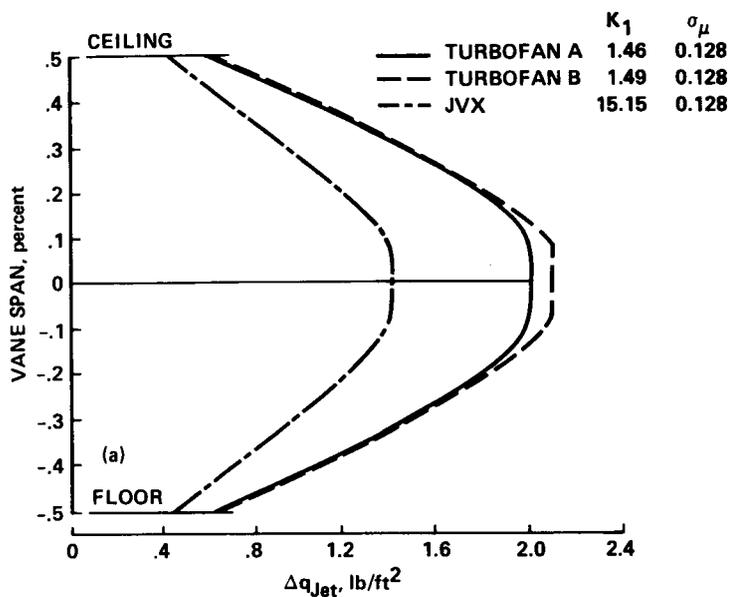
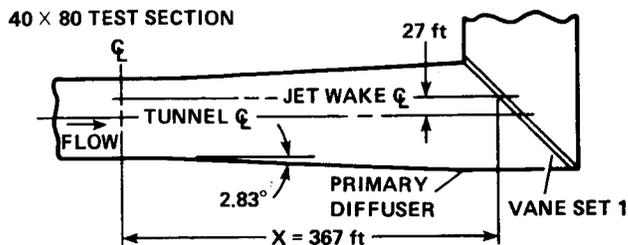
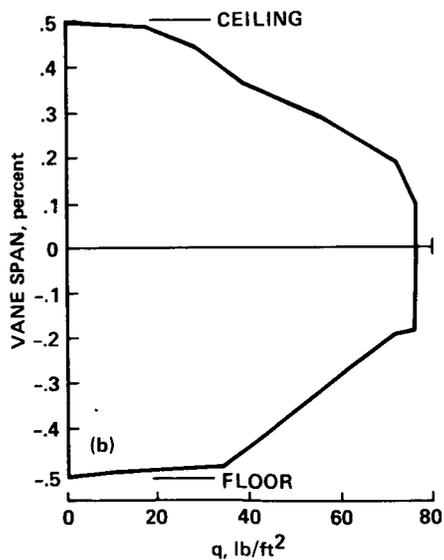

Figure 15.- Local load distribution on vane set owing to wake vortex.



(a) Dynamic pressure increment owing to jet wake.



(b) Dynamic pressure without jet effect; $\beta_1 = 48^\circ$, $\beta_2 = -45^\circ$.

Figure 16.- Maximum vertical dynamic pressure profile at vane set 1:
 $v_{fst} = 300$ knots, $q_{fst} = 262$ lb/ft².

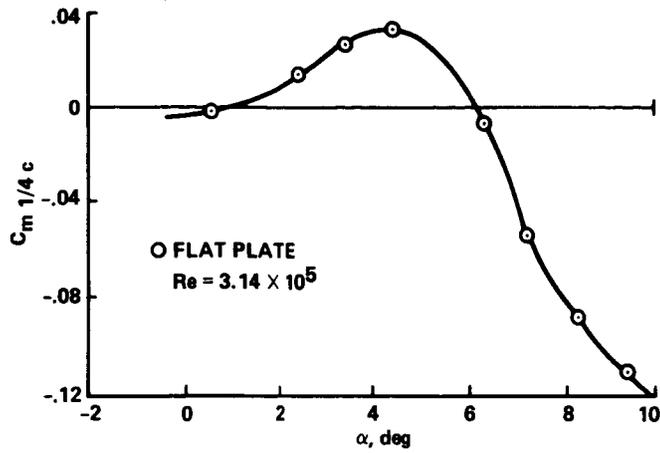
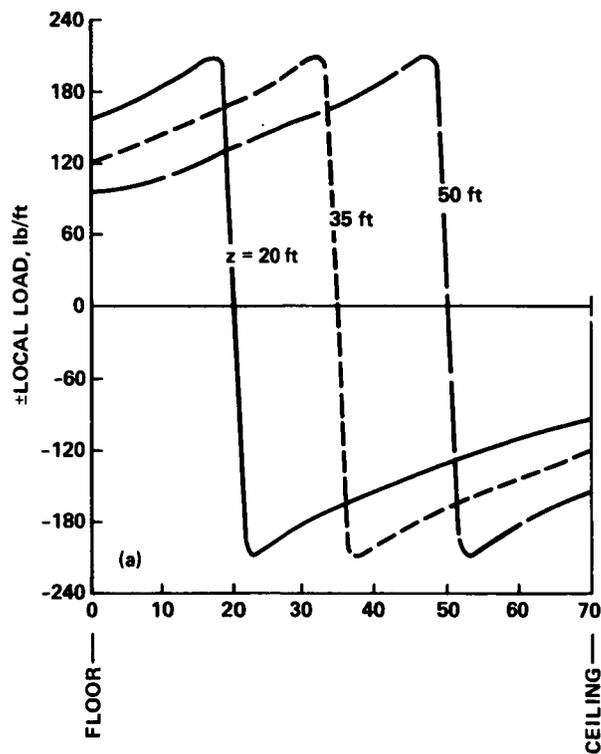
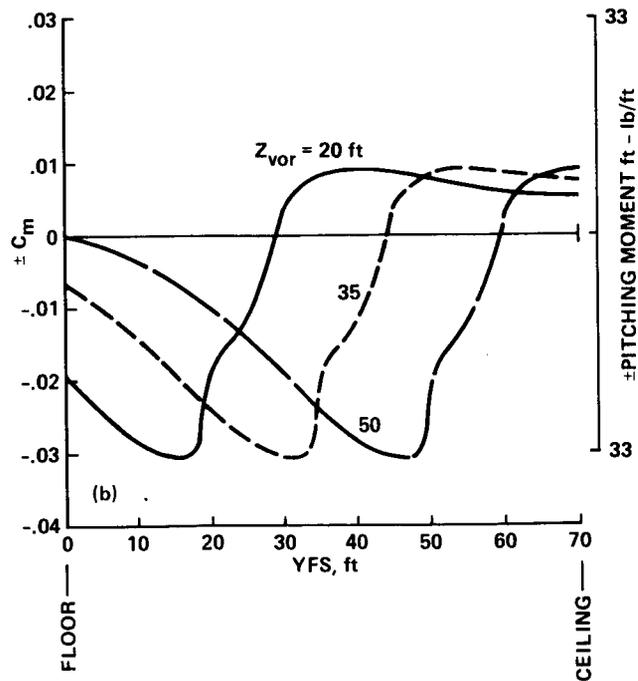

Figure 17.- Two-dimensional moment characteristic (ref. 8).



(a) Effect of vortex position on spanwise lift load distribution.

Figure 18.- Local load distribution on vane set 4 owing to vortex wake:
 model lift = 100,000 lb, $q_{fstS} = 33.6 \text{ lb/ft}^2$.



(b) Effect of vortex height on pitching moment about $1/4 c$ of vane 4C.

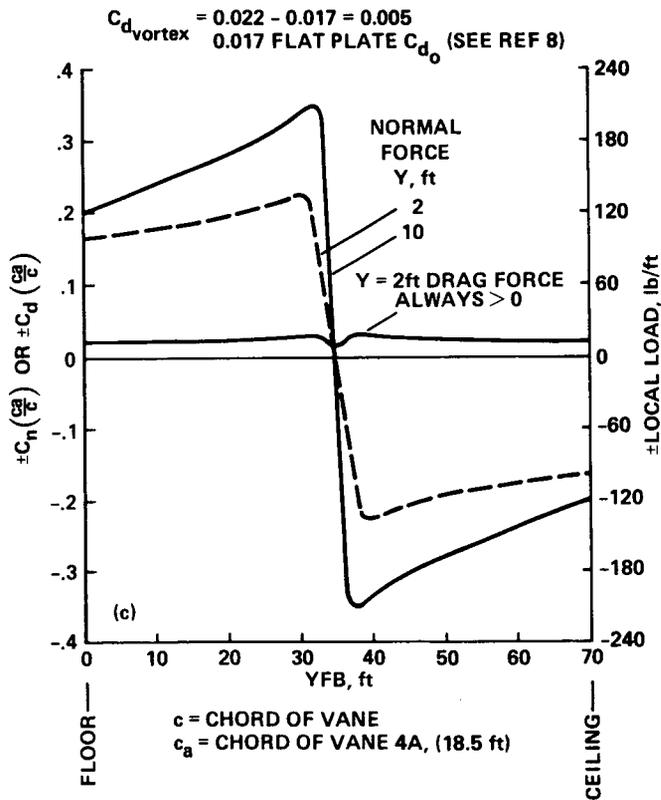

(c) Spanwise lift load distribution.

Figure 18.- Concluded.

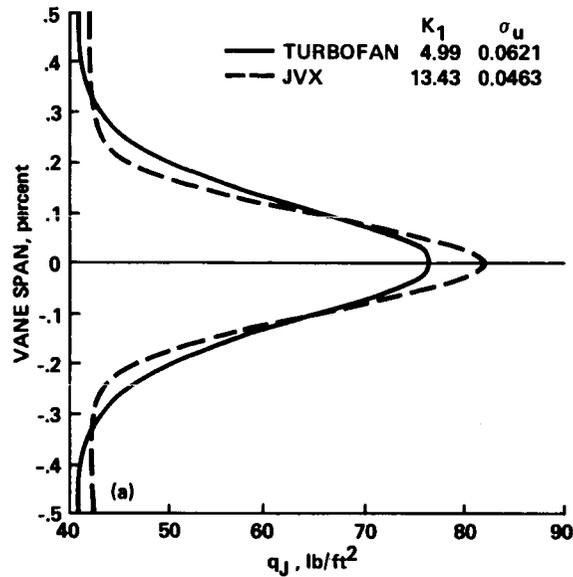
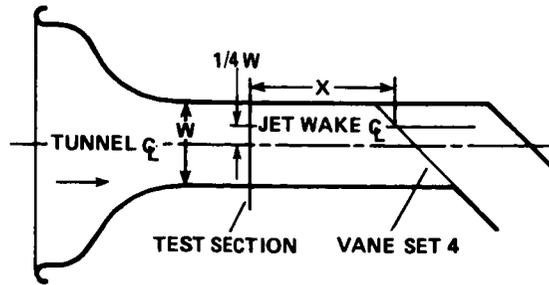

(a) Dynamic pressure.

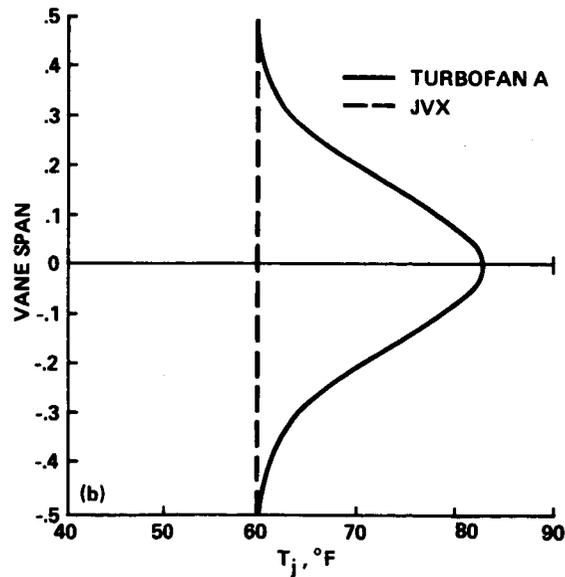

(b) Temperature.

Figure 19.- Variation of estimated jet dynamic pressure and temperature with vane set 4 span: $x = 205$ ft from 80×120 test section centerline, vane span = 69.3 ft.

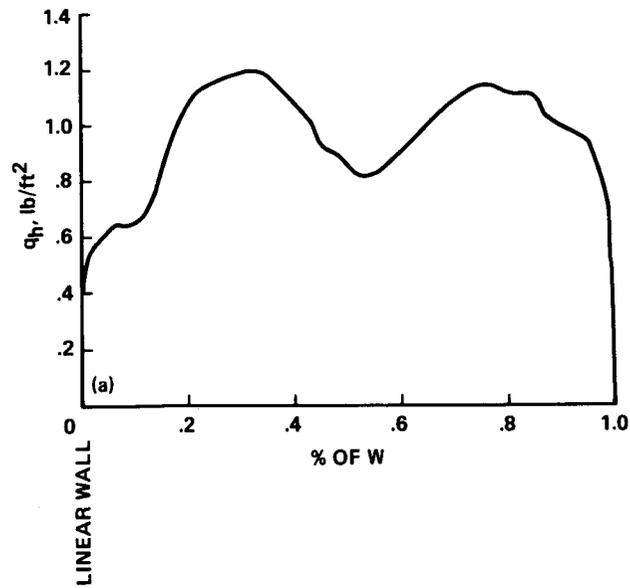

(a) Horizontal survey at the centerline perpendicular to the tunnel circuit centerline.

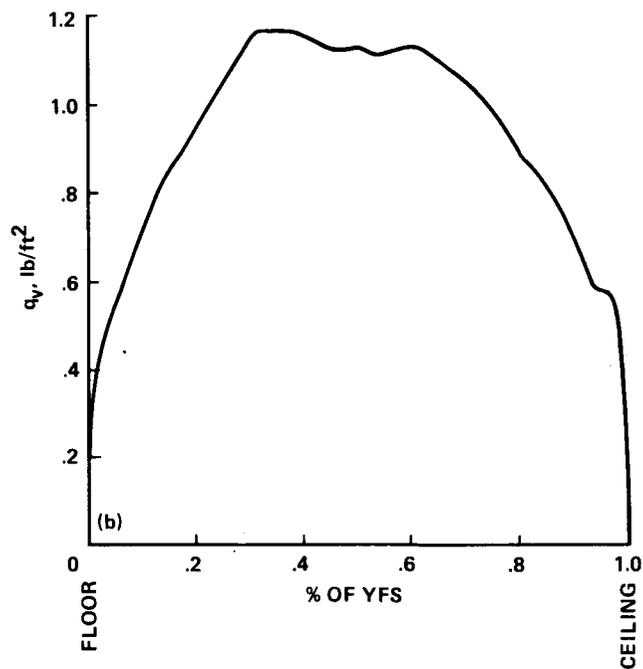

(b) Vertical survey, 0.22 W from inner wall.

Figure 20.- Dynamic pressure surveys in front of vane set 5: 40 x 80 mode, 1/50-scale 40 x 80 model, $q_{50ts} = 59.69 \text{ lb/ft}^2$, $m_{50} = 8.6\%$.

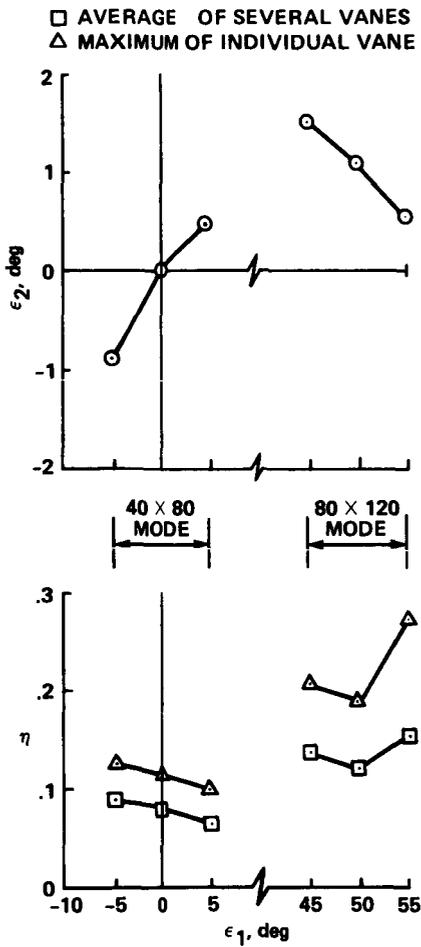
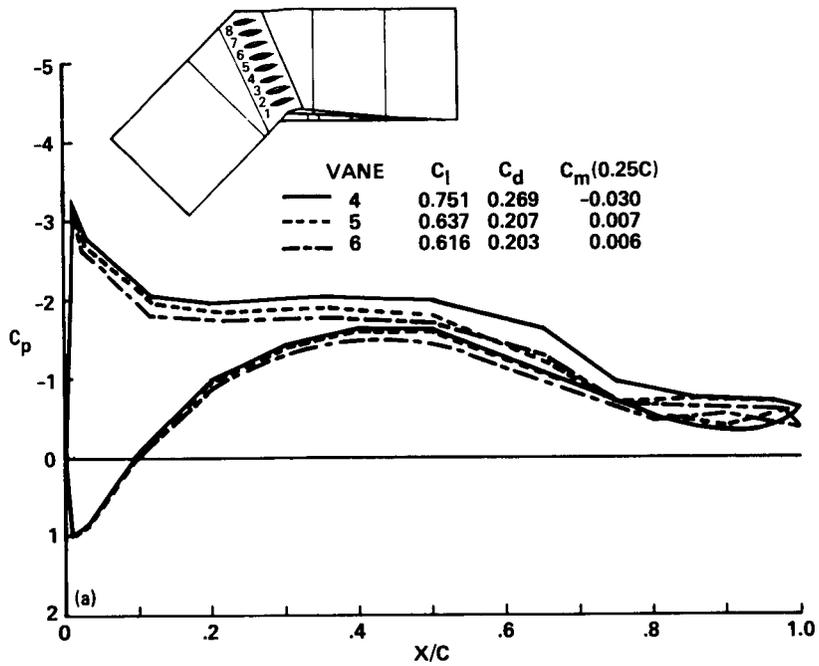
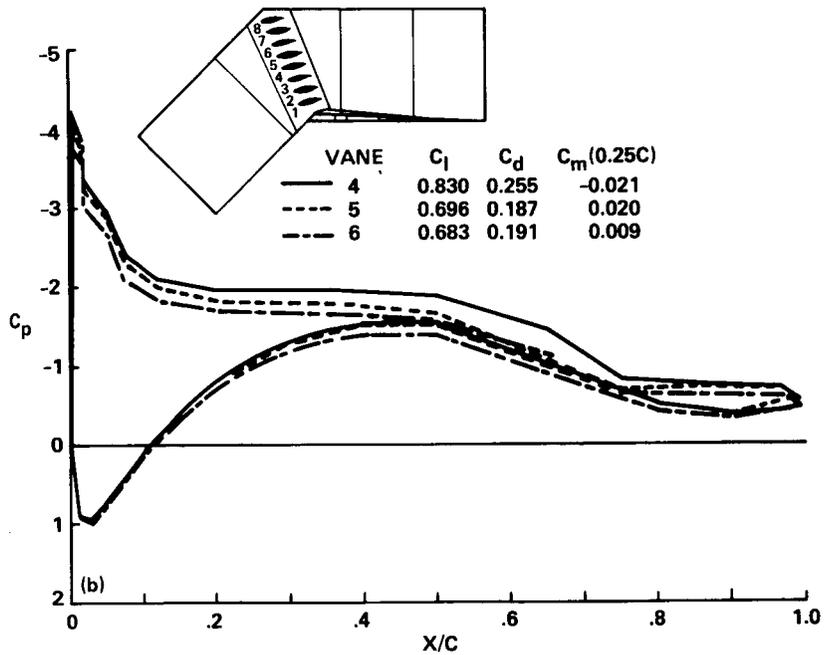

Figure 21.- Variation of loss coefficient and angle of outflow with angle of onset: vane set 5, Lewis Research Center fixed-vane design 3, 1/10-scale tester data.



(a) $\epsilon_1 = 45^\circ$, 80×120 mode.



(b) $\epsilon_1 = 50^\circ$, 80×120 mode.

Figure 22.- Chordwise surface-pressure distribution of vane set 5:
1/10-scale tester data.

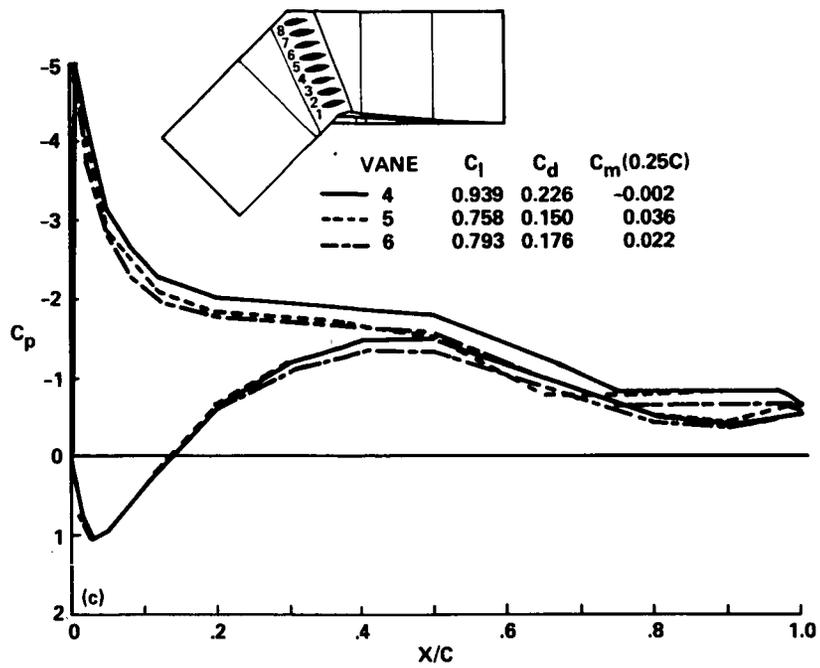

(c) $\epsilon_1 = 55^\circ$, 80×120 mode.

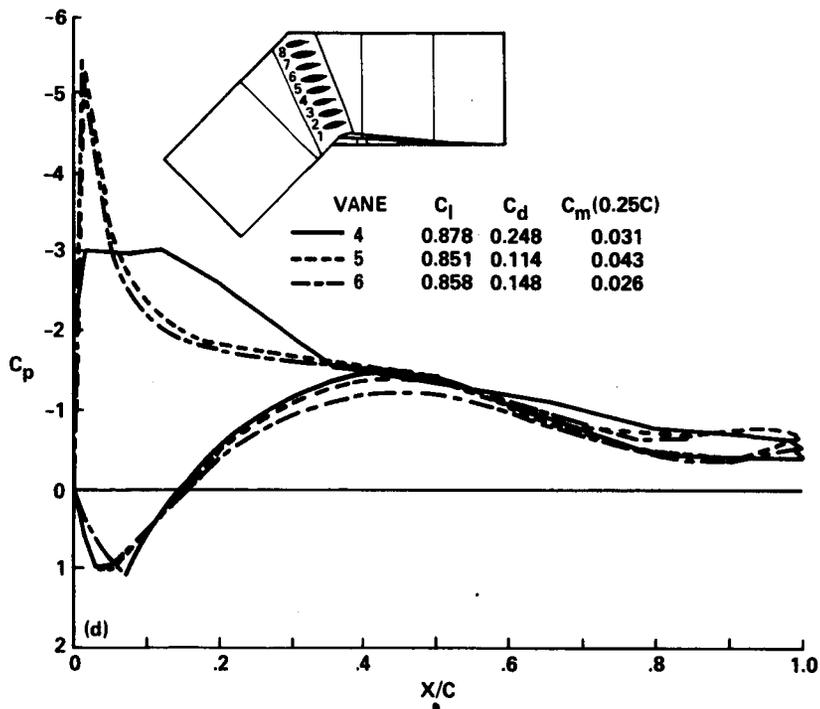

(d) $\epsilon_1 = 60^\circ$, 80×120 mode.

Figure 22.- Continued.

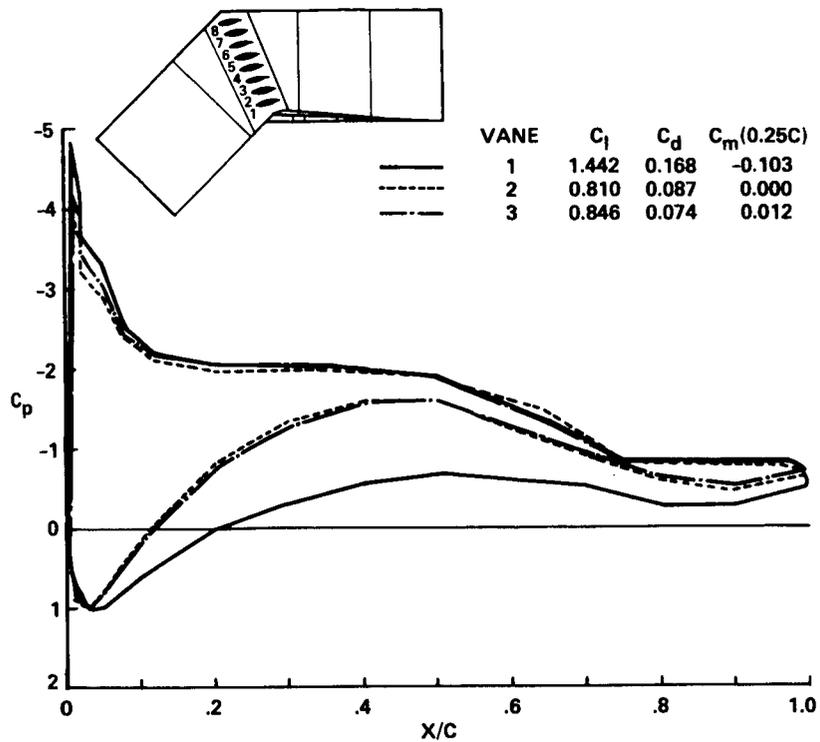

(e) $\epsilon_1 = 45^\circ$, wall effect, 80 x 120 mode.

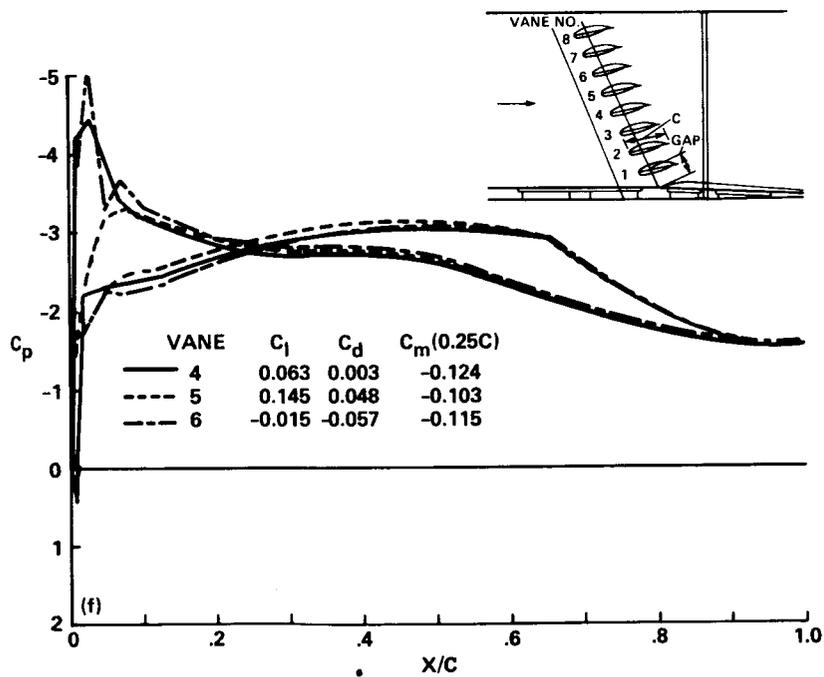

(f) $\epsilon_1 = 0^\circ$, 40 x 80 mode.

Figure 22.- Continued.

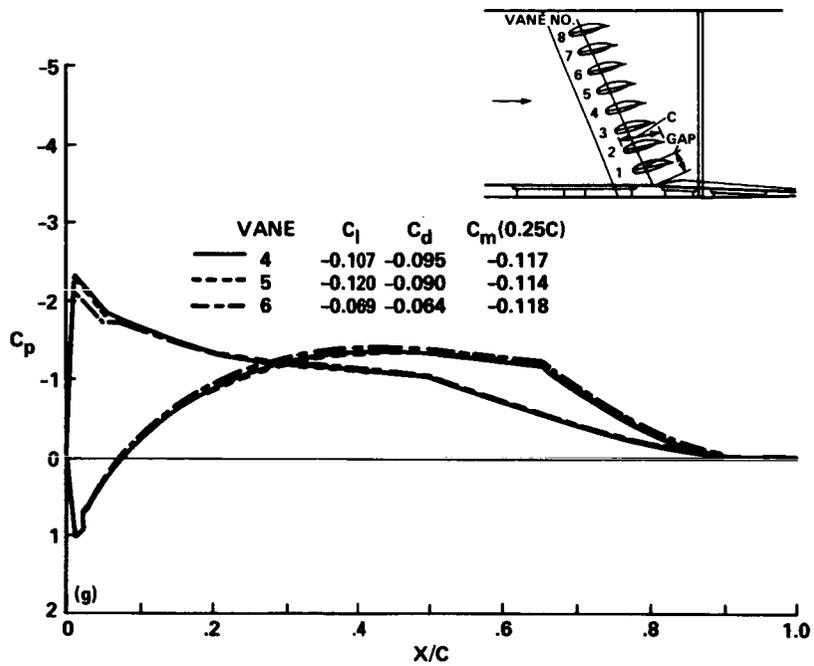

(g) $\epsilon_1 = -5^\circ$, 40×80 mode.

Figure 22.- Concluded.

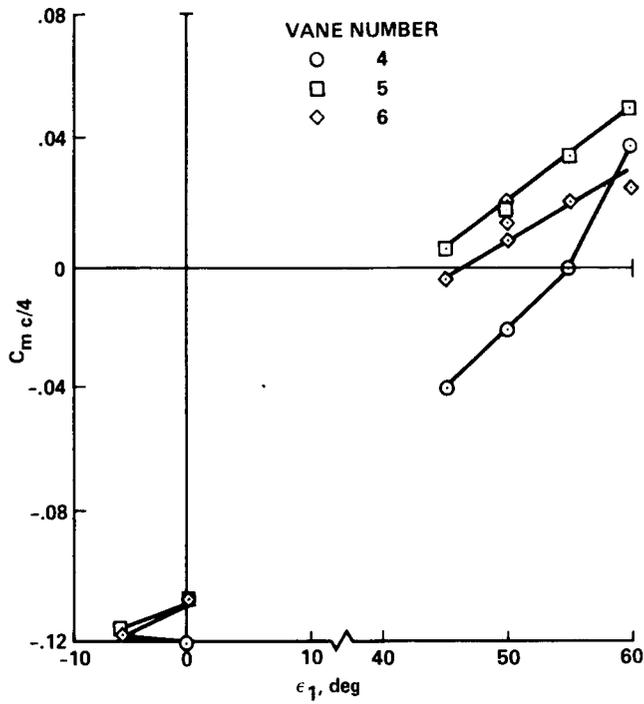

Figure 23.- Variation of c_m with onset angle: vane set 5, Lewis Research Center fixed-vane design 3, 1/10-scale tester data.

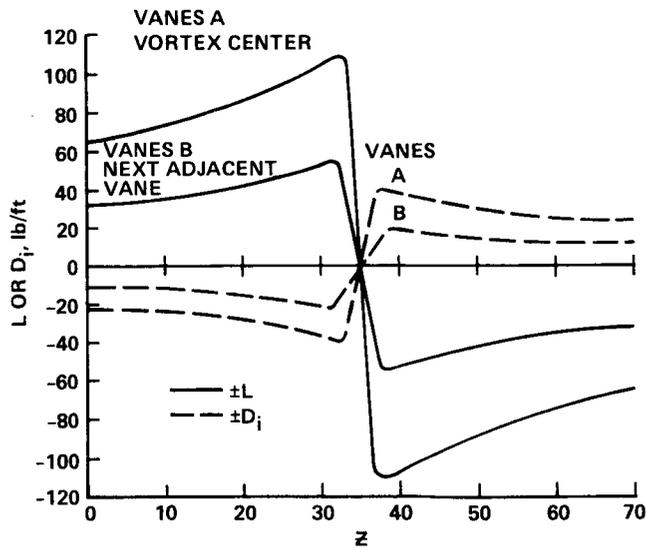
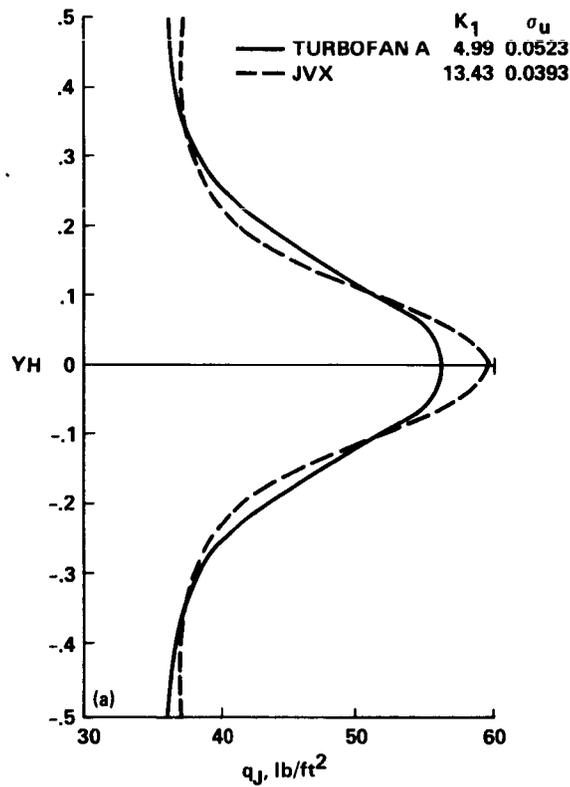
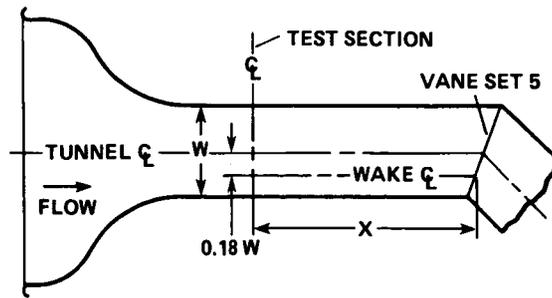
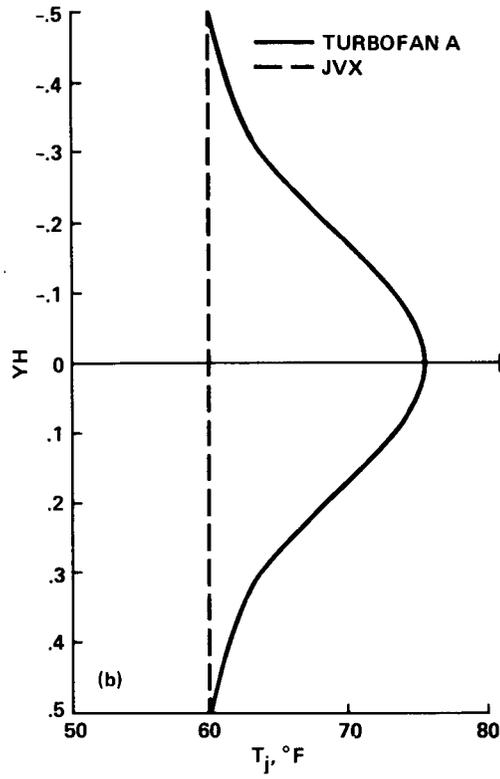

Figure 24.- Local load distribution on vane set 5 owing to a vortex wake: model lift 100,000 lb.



(a) Dynamic pressure.

Figure 25.- Variation of estimated jet dynamic pressure and temperature with vane set 5 span; $x = 303$ ft from 80×120 test section centerline,, vane span 75.4 ft.



(b) Temperature.

Figure 25.- Concluded.

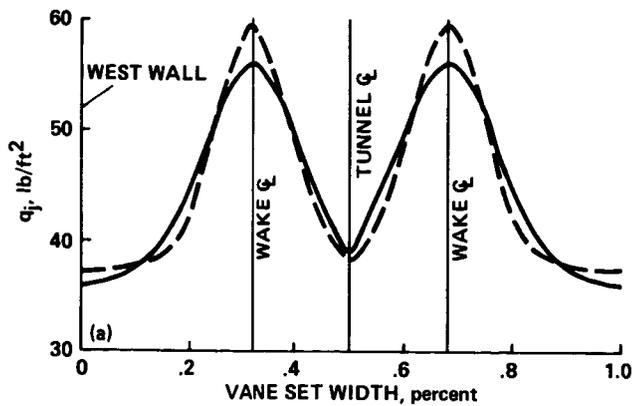

(a) Horizontal direction.

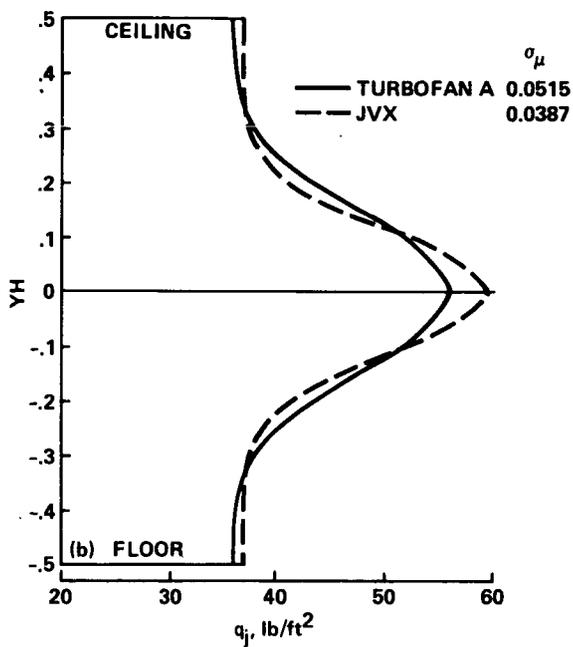

(b) Vertical direction.

Figure 26.- Estimated maximum dynamic pressure profiles of jet and propeller wakes at vane set 5: $x = 304$ ft.

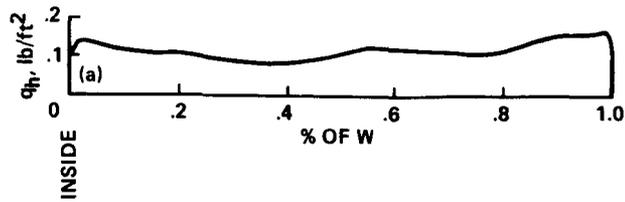

(a) Horizontal survey at vane set centerline normal to tunnel circuit centerline.

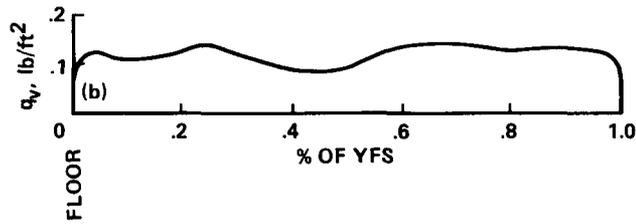

(b) Vertical survey, lateral station 0.414 of vane set one-half width from tunnel circuit centerline.

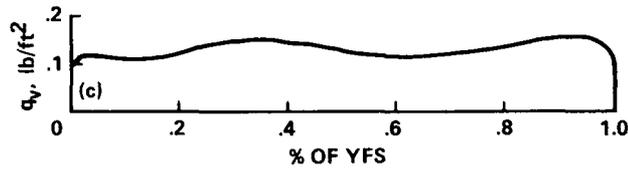

(c) Vertical survey lateral station 0.414 from centerline.

Figure 27.- Dynamic pressure surveys in front of vane set 6: 1/50-scale 40 x 80 model, $q_{50ts} = 59.76 \text{ lb/ft}^2$, $m_{50} = 8.6\%$.

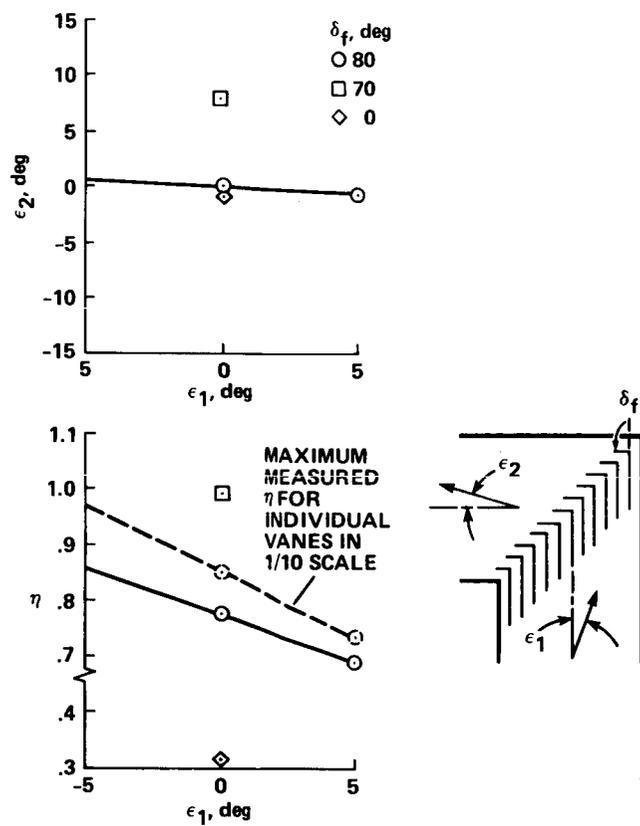
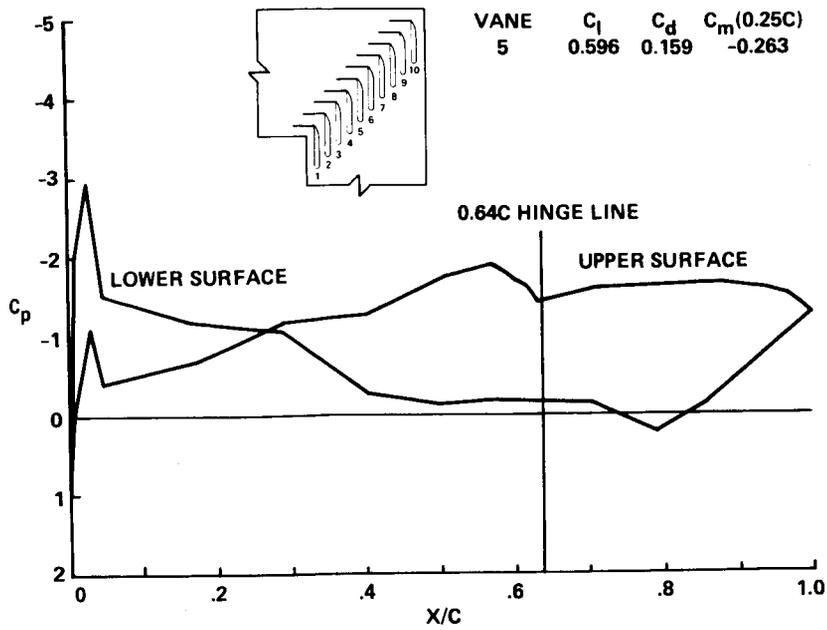
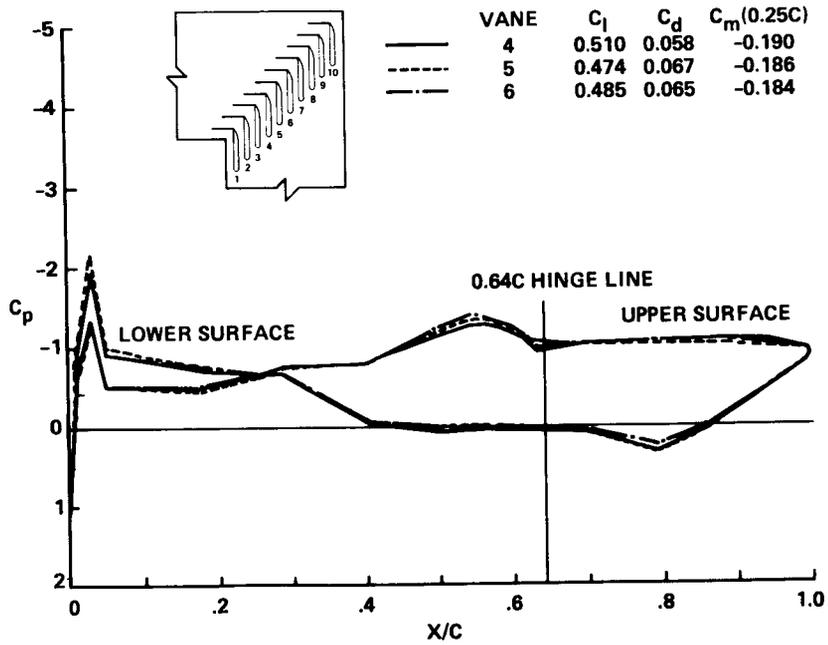

Figure 28.- Variation of loss coefficient and angle of outflow with angle of onset; vane set 6 with trailing-edge flap chord of 6 ft, 1/10-scale tester data.



(a) $\epsilon_1 = 0^\circ$, $\delta_f = 80^\circ$.



(b) $\epsilon_1 = 5^\circ$, $\delta_f = 80^\circ$.

Figure 29.- Chordwise pressure distribution of vane set 6 with trailing-edge flap of 6 ft; 1/10-scale tester data.

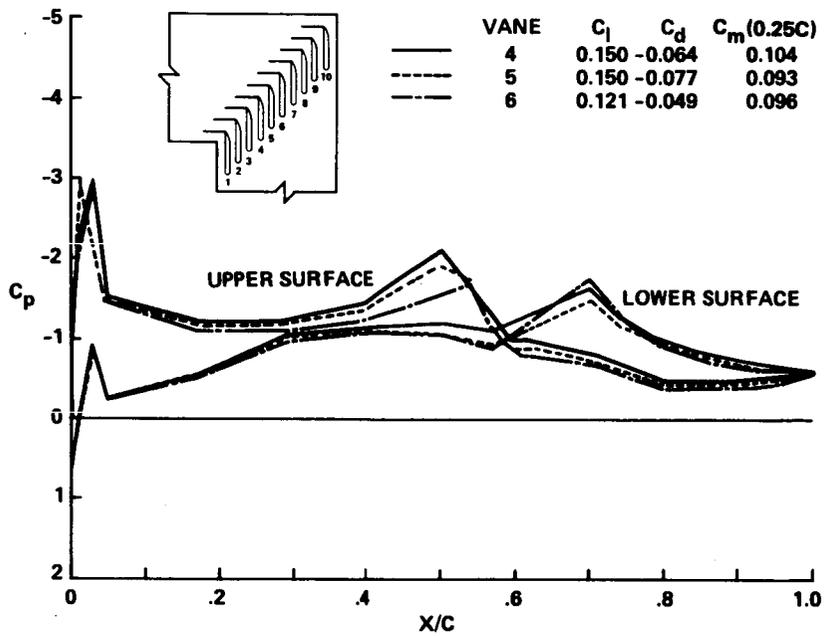

(c) $\epsilon_1 = 0^\circ$, $\delta_F = 0^\circ$.

Figure 29.- Concluded.

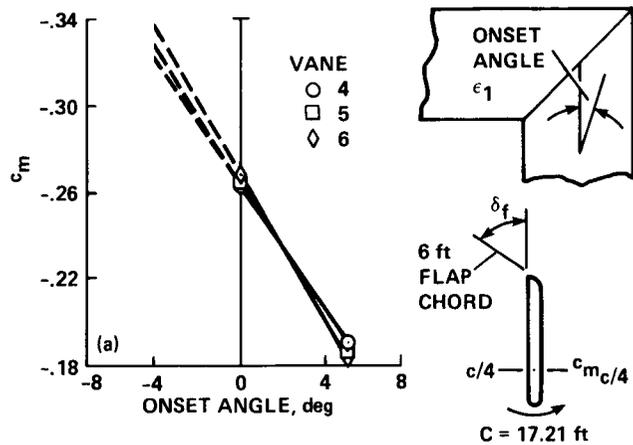

(a) Effect of angle of onset; $\delta_f = 80^\circ$.

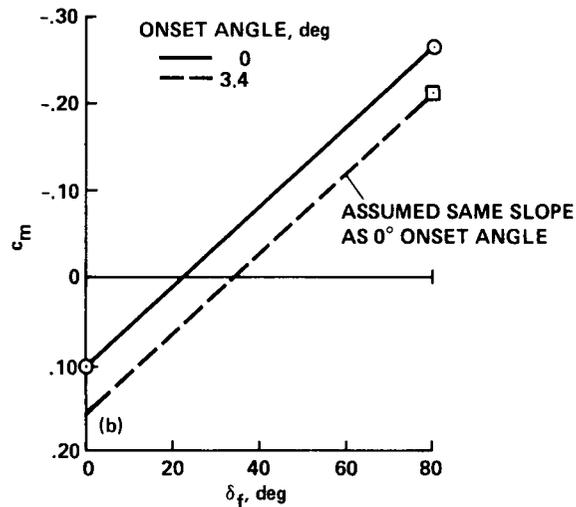

(b) Effect of trailing-edge flap deflection.

Figure 30.- Variation of vane set 6 c_m about 1/4 vane chord; 1/10-scale tester data.

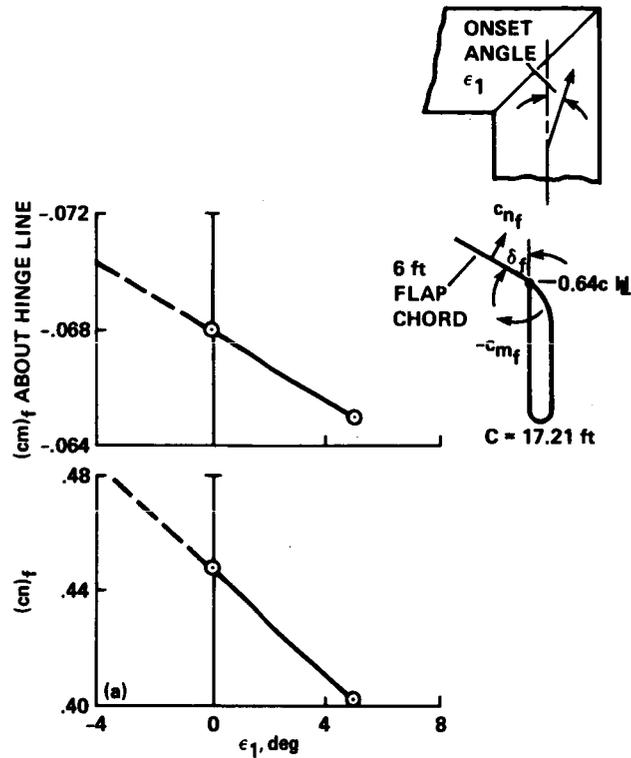

(a) Effect of angle of onset; $\delta_f = 80^\circ$.

Figure 31.- Variation of trailing-edge flap normal force and hinge moment coefficients of vane set 6; 1/10-scale tester data.

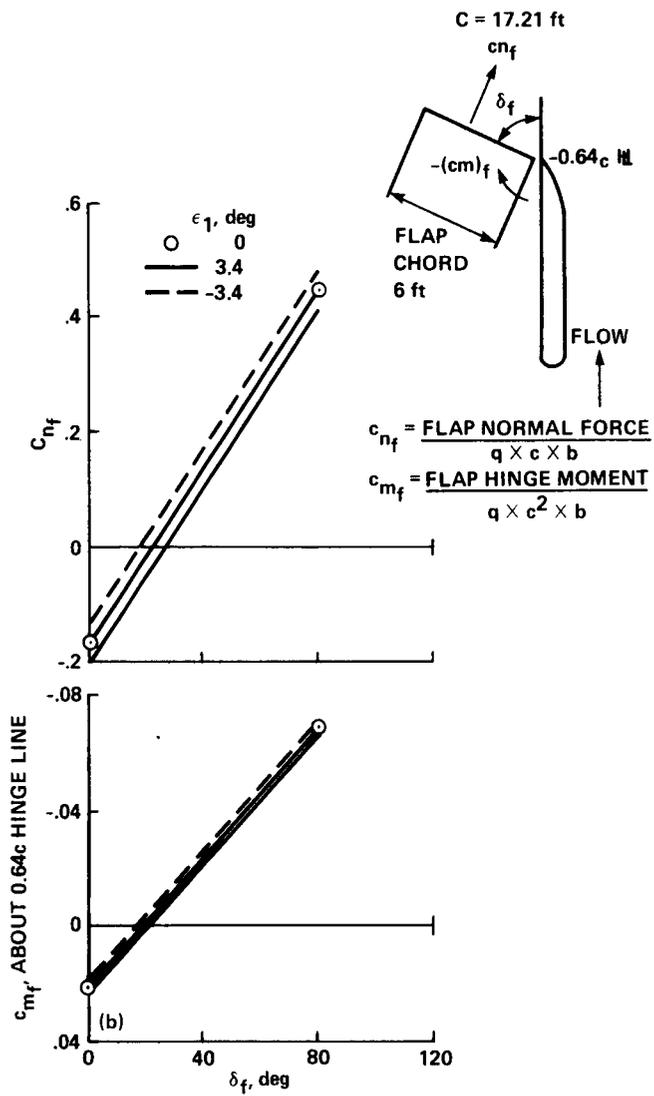

(b) Effect of flap deflection.

Figure 31.- Concluded.

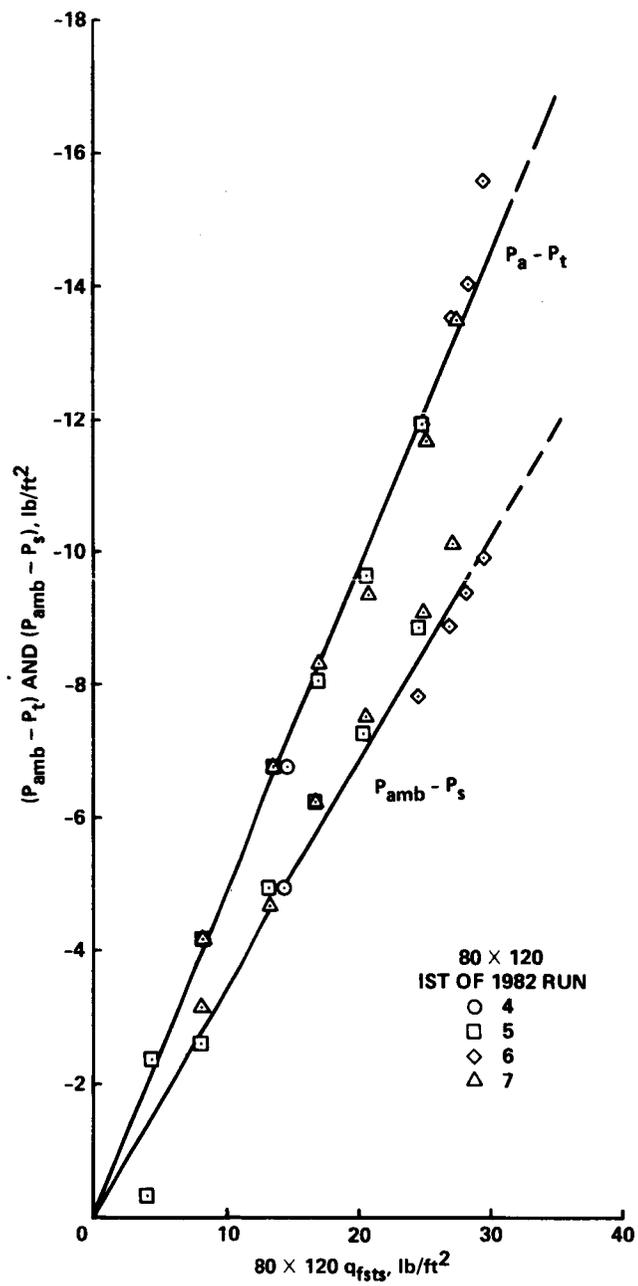
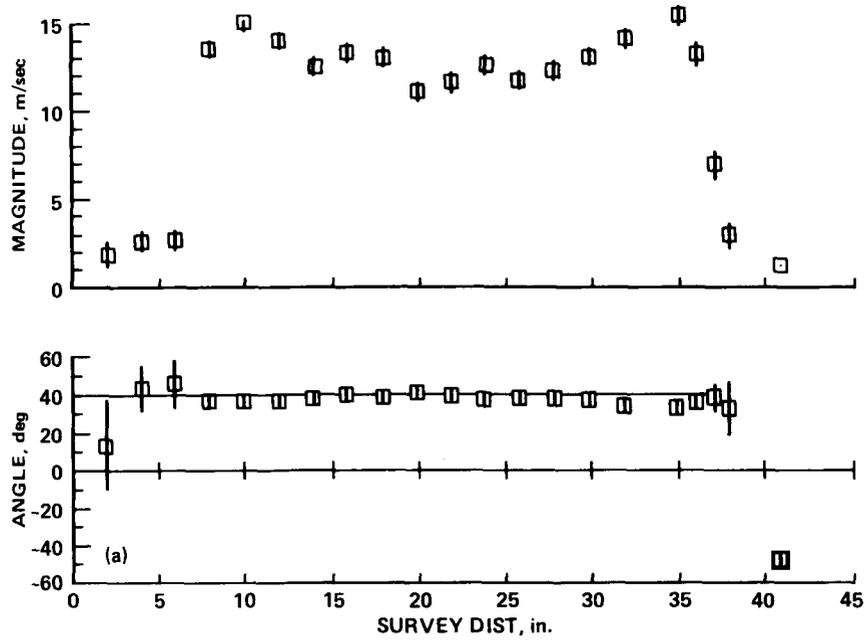
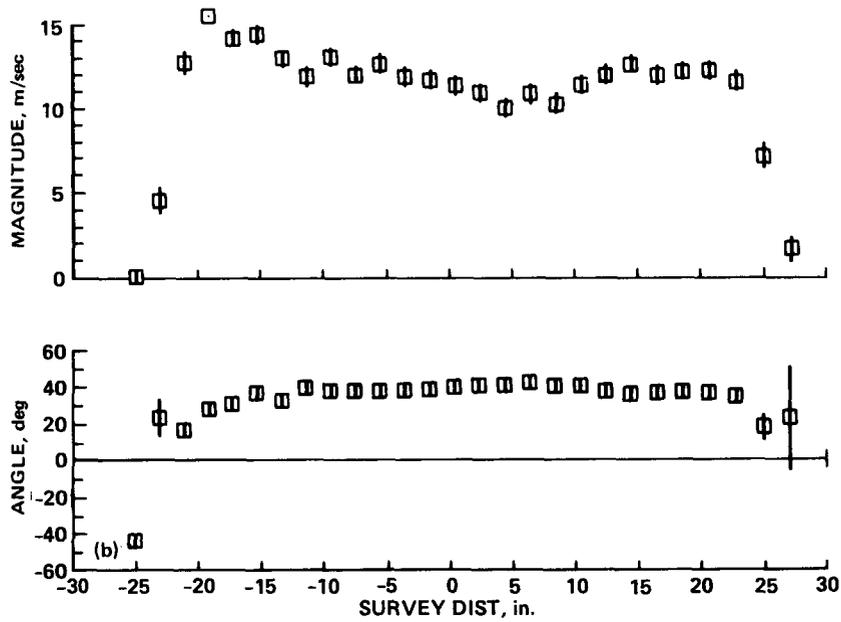

Figure 32.- Variation of total and static pressures in front of vane set 7 with 80 x 120 test section dynamic pressures; 80- by 120-Foot Wind Tunnel IST of 1982.



(a) Vertical survey at vane set centerline 8 in. beyond wall exit.



(b) Horizontal survey 20 in. above the ground and 8 in. beyond wall exit.

Figure 33.- 1/50-scale 80 x 120 model laser survey of vane set 7 exit velocity and direction with exit ramp.

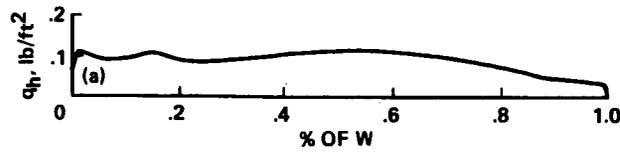

(a) Horizontal survey at vane set centerline parallel to the vane set stagger line.

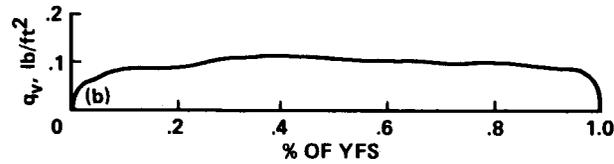

(b) Vertical survey at vane set centerline.

Figure 34.- Dynamic pressure surveys in front of vane set 8: 1/50-scale 40 x 80 model, $q_{50ts} = 59.25 \text{ lb/ft}^2$, $m = 8.6\%$.

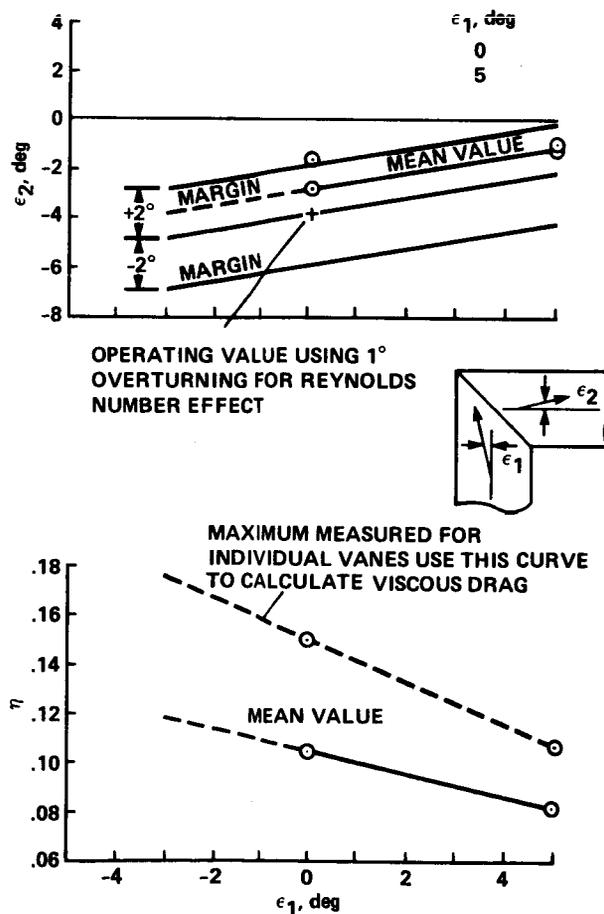
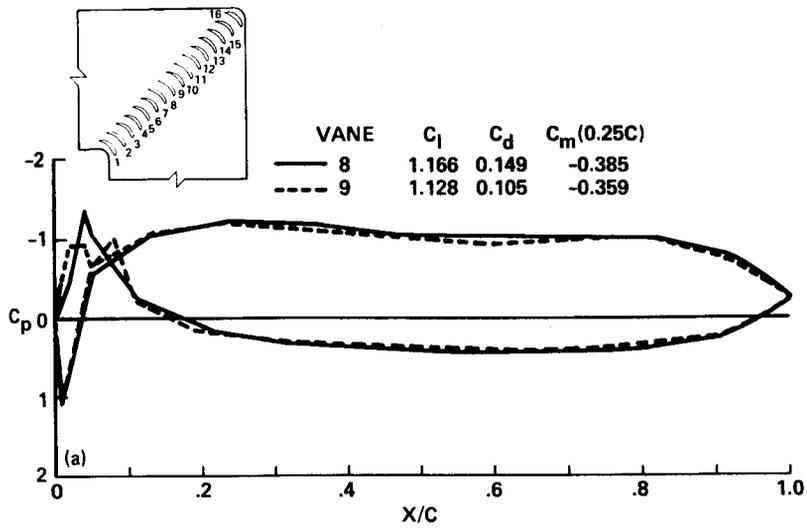
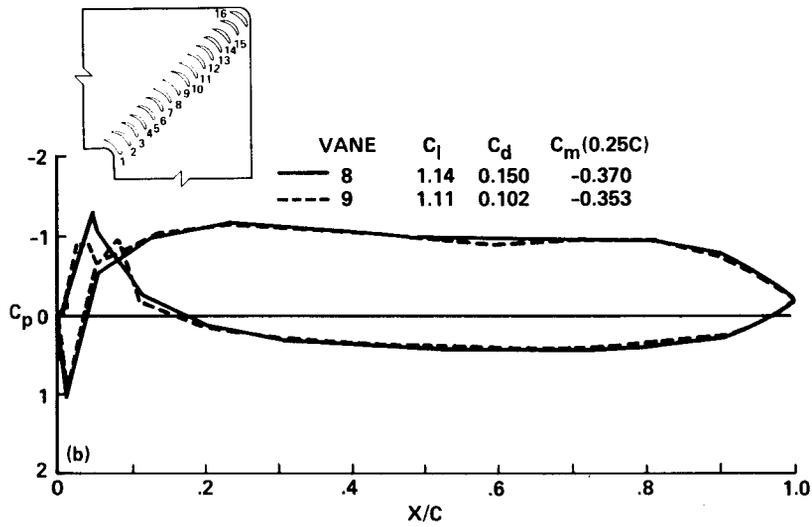

Figure 35.- Variation of pressure loss coefficient and ϵ_2 with ϵ_1 for vane set 8; 1/10-scale tester data.



(a) $\epsilon_1 = 0^\circ$, data sequence 2.



(b) $\epsilon_1 = 0^\circ$, data sequence 3.

Figure 36.- Chordwise pressure distribution of vane set 8: 1/10-scale tester data.

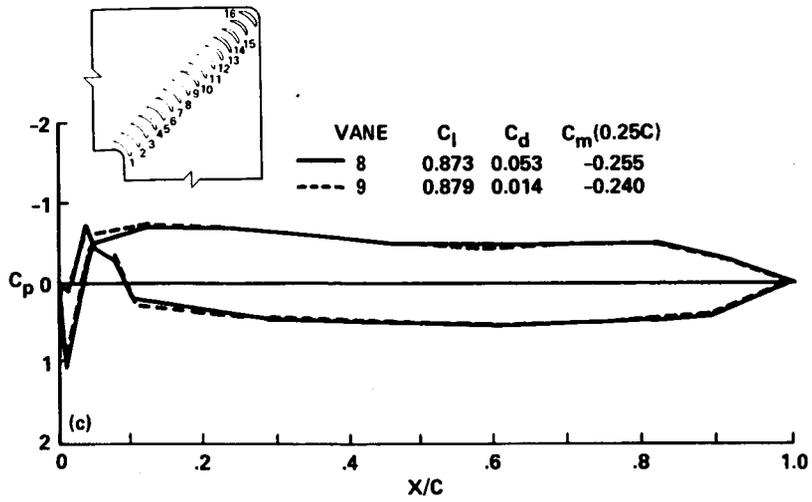

(c) $\epsilon_1 = 5^\circ$, data sequence 1.

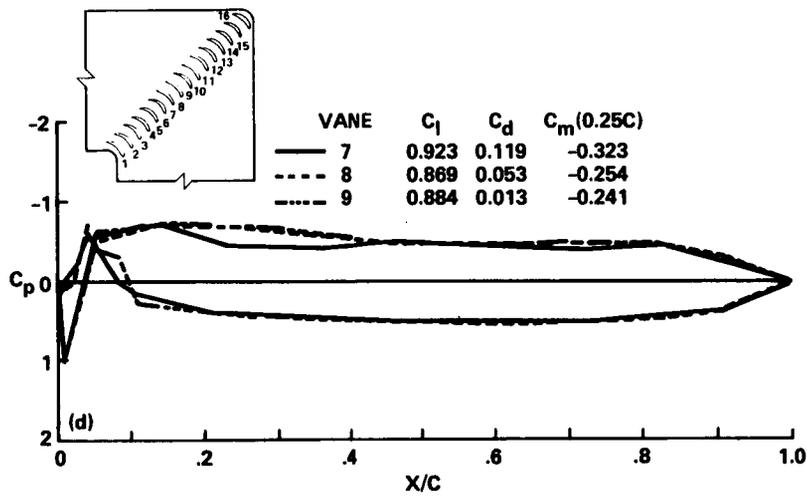

(d) $\epsilon_1 = 5^\circ$, data sequence 3.

Figure 36.- Concluded.

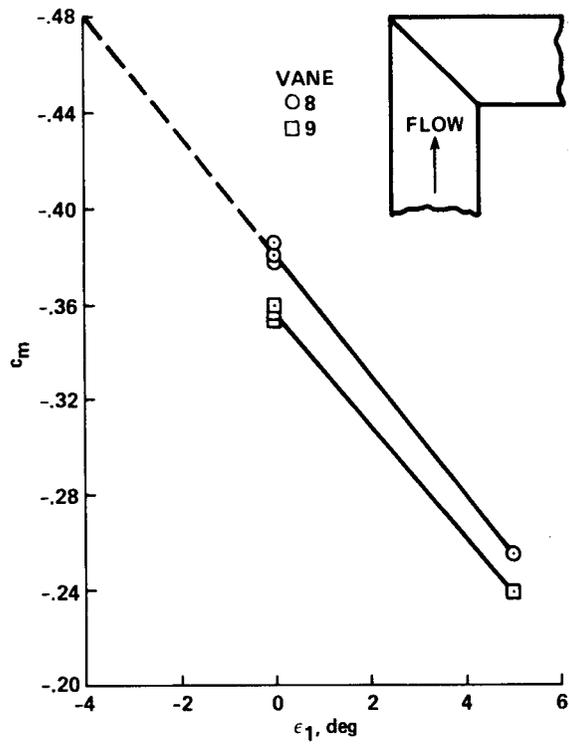
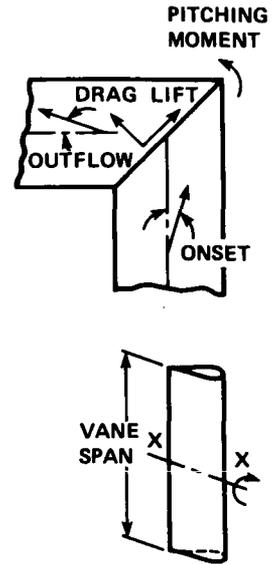

Figure 37.- Variation of vane set 8 pitching moment coefficient with angle of onset.

**AERODYNAMIC DESIGN TIME AVERAGED LOADS
VANE SETS 1 AND 2**

Global load (total vane span = 3429.0 ft)			Case 2
Onset angle	deg	1.0	-3.0
Outflow angle	deg	-2.0	-4.0
Lift	lb	911600.	771000.
Drag	lb	88400.	150000.
Pitching moment about vane 1/4 chord	ft-lb	-1206600.	-1235200.
Moment/vane about x-x axis (vortex effect)	ft-lb (±)	26000.	26000.



Note:

1. Loads acting at 1/4 vane chord.
2. Lift acting along vane set. Positive direction toward outside wall.
3. Drag perpendicular to vane set.
4. See figures for vane spanwise loads.

(a) Maximum global design loads.

Figure 38.- Global design and operating loads of vane sets 1 and 2.

AERODYNAMIC OPERATING TIME AVERAGED LOADS
VANE SETS 1 AND 2

Global load, vane set 1

Onset angle	deg	1.0
Outflow angle	deg	0.0
Lift	lb	765200.
Drag	lb	48600.
Pitching moment	ft-lb	-1048900.
about vane 1/4 chord		

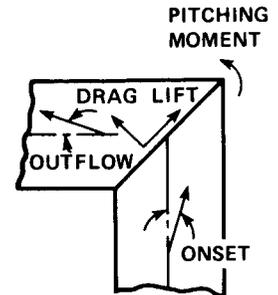

Global load, vane set 2 with 10% air exchange

Onset angle	deg	0.0
Outflow angle	deg	0.0
Lift	lb	864900.
Drag	lb	68900.
Pitching moment	ft-lb	-1265800.
about vane 1/4 chord		

Note:

1. Loads acting at 1/4 vane chord.
2. Lift acting along vane set. Positive direction toward outside wall.
3. Drag perpendicular to vane set.

(b) Global operating loads.

Figure 38.- Continued.

VANE 1 DESIGN GLOBAL AND LOCAL LOADS
40 BY 80 MODE

CONSTANT INPUTS	KNOTS	SPLITTER PLATE CD	SQ FT	0.025
TUNNEL SPEED	300.00	TOTAL SPLITTER PLATE		4612.0
TEMP. AROUND TUNL	70.0	AREA (PLANFORM)		5.0
TEST SECTION Q	262.44	NO. OF SPLITTER PLATES		
MASS DENSITY AT VANE	0.002272			
DP/QL ROUGHNESS	0.04			
VANE SET FRONTAL AREA	10544.0			
INDIVID. VANE SPAN	68.6			
NO. OF VANES	50.0			
PITCH OF VANE SET	3.0			
VANE CHORD	6.0			
TOTAL VANE SPAN	3429.0			
CALCULATION				
ONSET ANGLE	3.0	-3.0	-3.0	
OUTFLOW ANGLE	0.0	0.0	-4.0	
BETA 1	48.0	42.0	42.0	
BETA 2	-45.0	-45.0	-49.0	
Q AT 0 DEG ONSET	32.3	32.3	32.3	
VZ	119.2	119.2	119.2	
Q AT ONSET ANGLE	36.0	29.2	29.2	
DP/QL VISCOUS DRAG COEFF	0.078	0.074	0.074	
CM ABOUT 1/4 CHORD	-0.190	-0.310	-0.310	
K1 (V/VAVG)2*A	1.105	1.105	1.105	
QMAX/QAVG	2.176	2.176	2.176	
MOMENTUM LIFT	793426.8	71404.6	770931.5	
OTHER LIFT	0.0	0.0	0.0	
TOTAL LIFT	793426.8	71404.6	770931.5	
INVISCID DRAG	-43881.4	35575.9	96352.7	
VISCOUS DRAG	32744.7	25185.6	25185.6	
INVISCID+VISCOUS DRAG	-11136.7	60761.5	121538.3	
ROUGHNESS DRAG	16792.2	13613.9	13613.9	
SPLITTER PLATE DRAG	18362.4	14886.9	14886.9	
OTHER DRAG	0.0	0.0	0.0	
TOTAL DRAG	24017.9	89262.3	150039.1	
PITCHING MOMENT C/4	-933823.4	-1235229.8	-1235229.8	
MOMENT/VANE ABOUT X-X AXIS (VORTEX EFFECT)	FTLB(+/-) 26000.0	26000.0	26000.0	

(c) Vane set 1 tabulated global loads.

Figure 38.- Continued.

VANE 2 DESIGN GLOBAL AND LOCAL LOADS
4Ø BY 8Ø MODE

CONSTANT INPUTS	KNOTS	SPLITTER PLATE CD	SQ FT	Ø.Ø25
TUNNEL SPEED	300.00	TOTAL SPLITTER PLATE	4612.0	
TEMP. AROUND TUNL CIRCUIT	70.0	AREA (PLANFORM)		
TEST SECTION Q	262.44	NO. OF SPLITTER PLATES	5.0	
MASS DENSITY AT VANE	0.002271	1Ø PERCENT AIR EXCHANGE		
DP/QL ROUGHNESS	0.04			
VANE SET FRONTAL AREA	10544.0			
INDIVID. VANE SPAN	68.6			
NO. OF VANES	50.0			
PITCH OF VANE SET	3.0			
VANE CHORD	6.0			
TOTAL VANE SPAN	3429.0			
CALCULATION				
ONSET ANGLE	1.0	1.0	-1.0	-1.0
CUTFLOW ANGLE	-2.0	2.0	-2.0	2.0
BETA 1	46.0	46.0	44.0	44.0
BETA 2	-47.0	-43.0	-47.0	-43.0
Q AT Ø DEG ONSET	39.1	39.1	39.1	39.1
VZ	131.2	131.2	131.2	131.2
Q AT ONSET ANGLE	40.5	40.5	37.8	37.8
DP/QL VISCOUS DRAG COEFF	0.076	0.076	0.075	0.075
CM ABOUT 1/4 CHORD	-0.230	-0.230	-0.270	-0.270
K1 (V/VAVG)2*A	1.050	1.050	1.050	1.050
QMAX/QAVG	1.485	1.485	1.485	1.485
MOMENTUM LIFT	911604.6	881400.2	820917.6	820917.6
OTHER LIFT	0.0	0.0	0.0	0.0
TOTAL LIFT	911604.6	881400.2	820917.6	820917.6
INVISCID DRAG	16791.0	47013.8	-13616.4	-13616.4
VISCOUS DRAG	34056.3	31341.5	31341.5	31341.5
INVISCID+VISCOUS DRAG	50847.3	78355.3	17725.1	17725.1
ROUGHNESS DRAG	17924.4	16715.5	16715.5	16715.5
SPLITTER PLATE DRAG	19600.5	18278.6	18278.6	18278.6
OTHER DRAG	0.0	0.0	0.0	0.0
TOTAL DRAG	88372.2	113349.4	52719.1	52719.1
PITCHING MOMENT C/4	-1206636.9	-1320951.6	-1320951.6	-1320951.6

(d) Vane set 2 tabulated global design loads.

Figure 38.- Concluded.

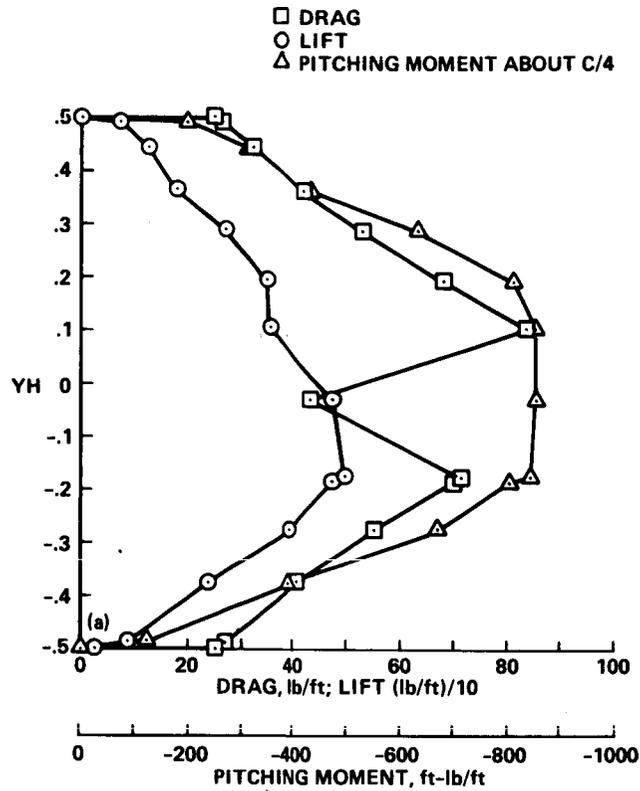

(a) Vortex center at vane midspan: $\epsilon_1 = 3.0^\circ$, $\epsilon_2 = 0^\circ$.

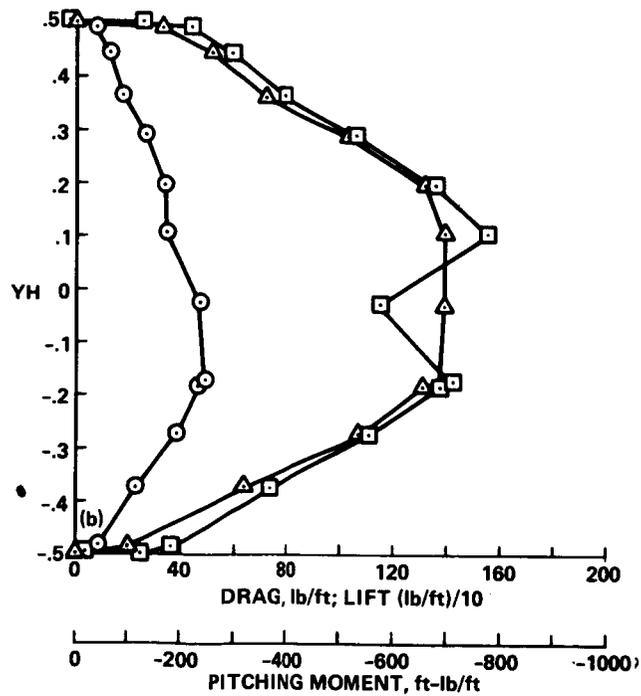

(b) Vortex center at vane midspan: $\epsilon_1 = -3.0^\circ$, $\epsilon_2 = -4.0^\circ$.

Figure 39.- Variation of estimated maximum local design load with vane span for vane set 1; $YH = -0.232$.

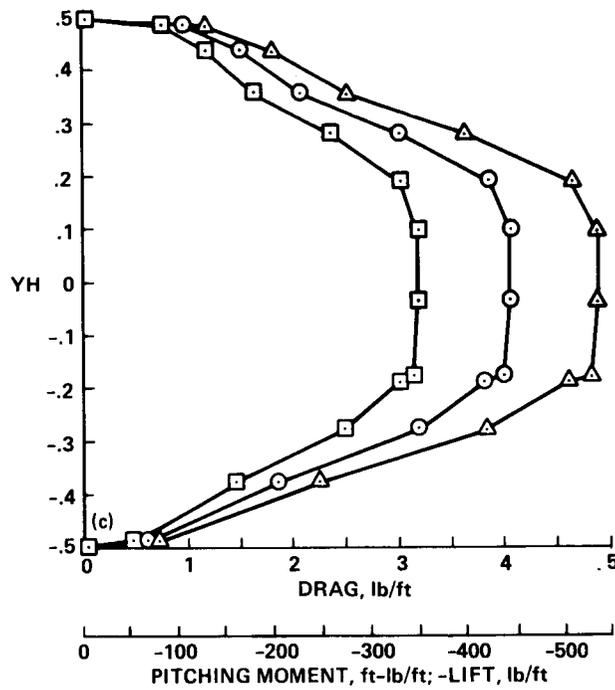

(c) Turbofan A jet-wake center at vane midspan: $\epsilon_1 = -3.0^\circ$, $\epsilon_2 = 0^\circ$.

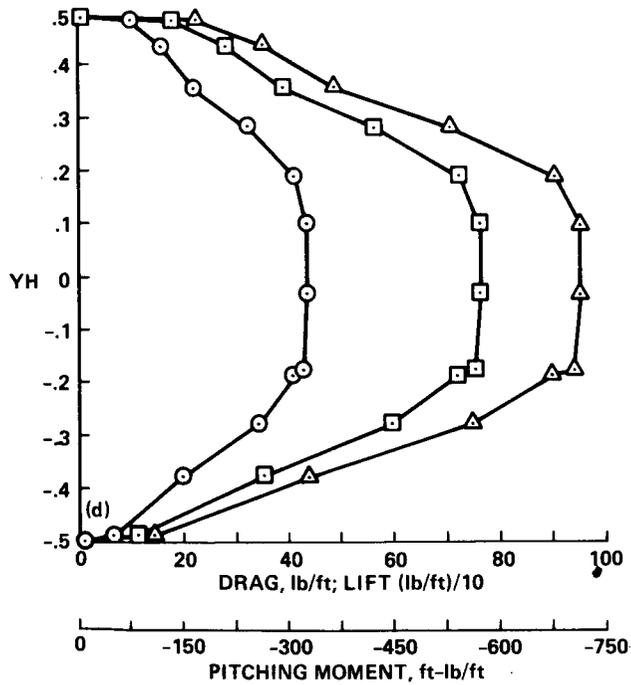

(d) Turbofan A jet-wake center at vane midspan: $\epsilon_1 = -3.0^\circ$, $\epsilon_2 = -4.0^\circ$.

Figure 39.- Continued.

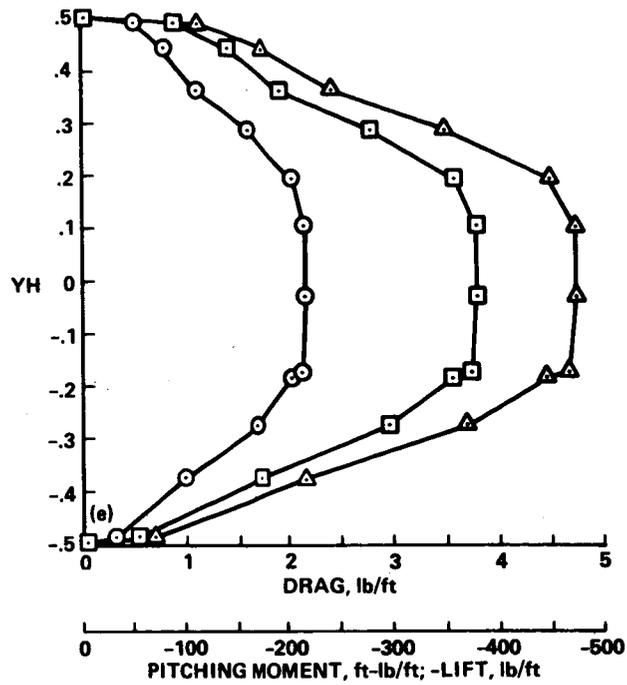

(e) JVX propeller wake at vane midspan: $\epsilon_1 = 3.0^\circ$, $\epsilon_2 = 0^\circ$.

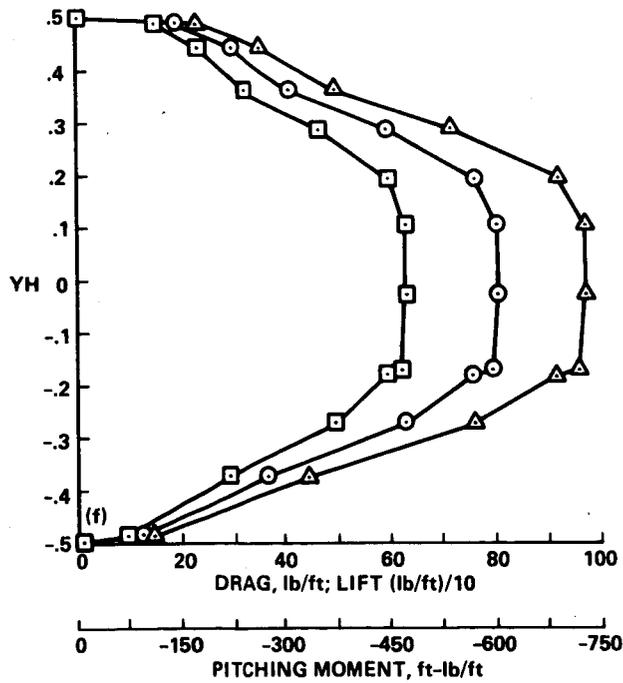

(f) JVX propeller wake center at vane midspan: $\epsilon_1 = -3.0^\circ$, $\epsilon_2 = -4.0^\circ$.

Figure 39.- Continued.

FULL-SCALE LOADS																							
VISCIOUS DRAG(LB/FT)= DV				INVISCID DRAG(LB/FT)= DI				LOCAL Q(LB/FT ²)= QFS				JET Q(LB/FT ²)= QJ											
TOTAL DRAG(LB/FT)= DT.				INVISCID LIFT(LB/FT)= LI				VANE HEIGHT(FT) =VFS				MOMENT ABOUT 1/4-CHORD(LB/FT)= MM											
1	YFS	YH	QFS	DV	DI	DVOR	DT	LI	LVOR	LT	M	1	YFS	YH	QFS	DV	DI	DVOR	DT	LI	LVOR	LT	M
1	-34.2900	-0.5000	0.0000	0.0000	0.0000	25.0000	25.0000	0.0000	25.0000	25.0000	0.0000	1	-34.2900	-0.5000	0.0000	0.0000	0.0000	25.0000	25.0000	25.0000	0.0000	0.0000	
2	-33.3985	-0.4870	10.9452	3.8746	-3.4322	26.4300	26.8723	62.0588	26.4300	88.4888	-122.1479	2	-33.3985	-0.4870	10.9452	3.8746	-3.4322	26.4300	26.8723	62.0588	26.4300	88.4888	-122.1479
3	-25.7175	-0.3750	34.9539	12.3737	-10.9610	39.2500	40.6626	198.1878	39.2500	237.4378	-390.0852	3	-25.7175	-0.3750	34.9539	12.3737	-10.9610	39.2500	40.6626	198.1878	39.2500	237.4378	-390.0852
4	-18.8595	-0.2750	60.0924	21.2727	-18.8441	52.7500	55.1786	340.7229	52.7500	393.4729	-670.6314	4	-18.8595	-0.2750	60.0924	21.2727	-18.8441	52.7500	55.1786	340.7229	52.7500	393.4729	-670.6314
5	-12.6187	-0.1840	72.3792	25.6222	-22.6971	66.8000	69.8052	410.3809	66.8000	477.2689	-807.7523	5	-12.6187	-0.1840	72.3792	25.6222	-22.6971	66.8000	69.8052	410.3809	66.8000	477.2689	-807.7523
6	-12.0015	-0.1750	75.7687	26.8221	-23.7600	68.5000	71.5622	429.6071	68.5000	498.1071	-845.5787	6	-12.0015	-0.1750	75.7687	26.8221	-23.7600	68.5000	71.5622	429.6071	68.5000	498.1071	-845.5787
7	-1.9888	-0.0290	76.7573	27.1721	-24.0700	80.6000	84.3821	435.2124	80.6000	475.8125	-856.6115	7	-1.9888	-0.0290	76.7573	27.1721	-24.0700	80.6000	84.3821	435.2124	80.6000	475.8125	-856.6115
8	7.1323	0.1040	76.7573	27.1721	-24.0700	81.2800	84.3821	435.2124	81.2800	353.9324	-856.6115	8	7.1323	0.1040	76.7573	27.1721	-24.0700	81.2800	84.3821	435.2124	81.2800	353.9324	-856.6115
9	13.3045	0.1940	72.8735	25.7972	-22.8521	65.0800	68.0252	413.1916	65.0800	348.1116	-813.2686	9	13.3045	0.1940	72.8735	25.7972	-22.8521	65.0800	68.0252	413.1916	65.0800	348.1116	-813.2686
10	19.7510	0.2880	56.8442	20.1228	-17.8255	50.8000	53.0973	322.3055	50.8000	271.5055	-634.3811	10	19.7510	0.2880	56.8442	20.1228	-17.8255	50.8000	53.0973	322.3055	50.8000	271.5055	-634.3811
11	24.8945	0.3630	39.1907	13.8735	-12.2896	40.8100	42.3939	222.2106	40.8100	181.4006	-437.3683	11	24.8945	0.3630	39.1907	13.8735	-12.2896	40.8100	42.3939	222.2106	40.8100	181.4006	-437.3683
12	30.4495	0.4440	28.2456	9.9989	-8.8574	31.1600	32.3015	160.1518	31.1600	128.9918	-315.2204	12	30.4495	0.4440	28.2456	9.9989	-8.8574	31.1600	32.3015	160.1518	31.1600	128.9918	-315.2204
13	33.6728	0.4910	18.0065	6.3743	-5.6466	25.9900	26.7177	102.0908	25.9900	76.1068	-200.9530	13	33.6728	0.4910	18.0065	6.3743	-5.6466	25.9900	26.7177	102.0908	25.9900	76.1068	-200.9530
14	34.2900	0.5000	0.0000	0.0000	0.0000	25.0000	25.0000	0.0000	25.0000	-25.0000	0.0000	14	34.2900	0.5000	0.0000	0.0000	0.0000	25.0000	25.0000	0.0000	-25.0000	0.0000	0.0000

Vortex effect.

1	YFS	YH	QFS	QJ	DV	DI	DT	LI	MM	1	YFS	YH	QFS	QJ	DV	DI	DT	LI	MM
1	-34.2900	-0.5000	0.0000	0.6000	0.2124	-0.1882	0.0242	3.4020	-4.1040	1	-34.2900	-0.5000	0.0000	0.6000	0.2124	-0.1882	0.0242	3.4020	-4.1040
2	-33.3985	-0.4870	10.9452	0.6600	4.1082	-3.6392	0.4690	65.8010	-79.3792	2	-33.3985	-0.4870	10.9452	0.6600	4.1082	-3.6392	0.4690	65.8010	-79.3792
3	-25.7175	-0.3750	34.9539	1.1400	12.7772	-11.3185	1.4587	204.6516	-246.8821	3	-25.7175	-0.3750	34.9539	1.1400	12.7772	-11.3185	1.4587	204.6516	-246.8821
4	-18.8595	-0.2750	60.0924	1.5500	21.8214	-19.3302	2.4913	349.5114	-421.6342	4	-18.8595	-0.2750	60.0924	1.5500	21.8214	-19.3302	2.4913	349.5114	-421.6342
5	-12.6187	-0.1840	72.3792	1.8300	26.2701	-23.2709	2.9991	420.7650	-507.5912	5	-12.6187	-0.1840	72.3792	1.8300	26.2701	-23.2709	2.9991	420.7650	-507.5912
6	-12.0015	-0.1750	75.7687	1.8500	27.4770	-24.3401	3.1369	440.0966	-530.9120	6	-12.0015	-0.1750	75.7687	1.8500	27.4770	-24.3401	3.1369	440.0966	-530.9120
7	-1.9888	-0.0290	76.7573	2.0000	27.8801	-24.6971	3.1829	446.5524	-538.7000	7	-1.9888	-0.0290	76.7573	2.0000	27.8801	-24.6971	3.1829	446.5524	-538.7000
8	7.1323	0.1040	76.7573	1.9800	27.8730	-23.6909	3.1821	446.4390	-538.5632	8	7.1323	0.1040	76.7573	1.9800	27.8730	-23.6909	3.1821	446.4390	-538.5632
9	13.3045	0.1940	72.8735	1.8100	26.4380	-23.4197	3.0183	423.4542	-510.8354	9	13.3045	0.1940	72.8735	1.8100	26.4380	-23.4197	3.0183	423.4542	-510.8354
10	19.7510	0.2880	56.8442	1.5000	20.6538	-18.2959	2.3580	330.8104	-399.0742	10	19.7510	0.2880	56.8442	1.5000	20.6538	-18.2959	2.3580	330.8104	-399.0742
11	24.8945	0.3630	39.1907	1.1800	14.2912	-12.6597	1.6316	228.9012	-276.1357	11	24.8945	0.3630	39.1907	1.1800	14.2912	-12.6597	1.6316	228.9012	-276.1357
12	30.4495	0.4440	28.2456	0.8500	10.2998	-9.1239	1.1759	164.9713	-199.0136	12	30.4495	0.4440	28.2456	0.8500	10.2998	-9.1239	1.1759	164.9713	-199.0136
13	33.6728	0.4910	18.0065	0.6600	6.6080	-5.8536	0.7544	105.8389	-127.6792	13	33.6728	0.4910	18.0065	0.6600	6.6080	-5.8536	0.7544	105.8389	-127.6792
14	34.2900	0.5000	0.0000	0.6000	0.2124	-0.1882	0.0242	3.4020	-4.1040	14	34.2900	0.5000	0.0000	0.6000	0.2124	-0.1882	0.0242	3.4020	-4.1040

Jet effect with turbofan A.

1	YFS	YH	QFS	QJ	DV	DI	DT	LI	MM	1	YFS	YH	QFS	QJ	DV	DI	DT	LI	MM
1	-34.2900	-0.5000	0.0000	0.4300	0.1522	-0.1348	0.0174	2.4381	-2.9412	1	-34.2900	-0.5000	0.0000	0.4300	0.1522	-0.1348	0.0174	2.4381	-2.9412
2	-33.3985	-0.4870	10.9452	0.4700	4.0410	-3.5796	0.4613	64.7237	-78.0797	2	-33.3985	-0.4870	10.9452	0.4700	4.0410	-3.5796	0.4613	64.7237	-78.0797
3	-25.7175	-0.3750	34.9539	0.7500	12.6392	-11.1962	1.4430	202.4403	-244.2145	3	-25.7175	-0.3750	34.9539	0.7500	12.6392	-11.1962	1.4430	202.4403	-244.2145
4	-18.8595	-0.2750	60.0924	1.0000	21.6267	-19.1577	2.4690	346.3929	-417.8722	4	-18.8595	-0.2750	60.0924	1.0000	21.6267	-19.1577	2.4690	346.3929	-417.8722
5	-12.6187	-0.1840	72.3792	1.2300	26.0577	-23.0828	2.9749	417.3630	-503.4872	5	-12.6187	-0.1840	72.3792	1.2300	26.0577	-23.0828	2.9749	417.3630	-503.4872
6	-12.0015	-0.1750	75.7687	1.2500	27.2646	-24.1519	3.1127	436.6946	-526.8080	6	-12.0015	-0.1750	75.7687	1.2500	27.2646	-24.1519	3.1127	436.6946	-526.8080
7	-1.9888	-0.0290	76.7573	1.4000	27.6677	-24.5090	3.1587	443.1504	-534.5959	7	-1.9888	-0.0290	76.7573	1.4000	27.6677	-24.5090	3.1587	443.1504	-534.5959
8	7.1323	0.1040	76.7573	1.3800	27.6606	-24.5027	3.1579	443.0370	-534.4591	8	7.1323	0.1040	76.7573	1.3800	27.6606	-24.5027	3.1579	443.0370	-534.4591
9	13.3045	0.1940	72.8735	1.2000	26.2220	-23.2284	2.9937	419.9955	-506.6630	9	13.3045	0.1940	72.8735	1.2000	26.2220	-23.2284	2.9937	419.9955	-506.6630
10	19.7510	0.2880	56.8442	0.9600	20.4627	-18.1266	2.3361	327.7486	-395.3806	10	19.7510	0.2880	56.8442	0.9600	20.4627	-18.1266	2.3361	327.7486	-395.3806
11	24.8945	0.3630	39.1907	0.7700	14.1461	-12.5311	1.6150	226.5765	-273.3313	11	24.8945	0.3630	39.1907	0.7700	14.1461	-12.5311	1.6150	226.5765	-273.3313
12	30.4495	0.4440	28.2456	0.5800	10.2022	-9.0393	1.1650	163.4404	-197.1668	12	30.4495	0.4440	28.2456	0.5800	10.2022	-9.0393	1.1650	163.4404	-197.1668
13	33.6728	0.4910	18.0065	0.4600	6.5372	-5.7908	0.7463	104.7049	-126.3111	13	33.6728	0.4910	18.0065	0.4600	6.5372	-5.7908	0.7463	104.7049	-126.3111
14	34.2900	0.5000	0.0000	0.4300	0.1522	-0.1348	0.0174	2.4381	-2.9412	14	34.2900	0.5000	0.0000	0.4300	0.1522	-0.1348	0.0174	2.4381	-2.9412

Propeller effect

(g) Tabulated data, $\epsilon_1 = 3.0^\circ$, $\epsilon_2 = 0^\circ$.

Figure 39.- Continued.

ORIGINAL PAGE IS
OF POOR QUALITY

FULL-SCALE LOADS
 VISCIOUS DRAG(LB/FT)= DV
 TOTAL DRAG(LB/FT)= DT
 INVISCID DRAG(LB/FT)= DI
 INVISCID LIFT(LB/FT)= LI
 LOCAL Q(LB/FT2)= QFS
 VANE HEIGHT(FT) =YFS
 JET Q(LB/FT2)= QJ
 MOMENT ABOUT 1/4-CHORD(LB/FT)= MM

I	YFS	YH	QFS	DV	DI	DVOR	DT	LI	LVOR	LT	M
1	-34.2900	-0.5000	0.0000	0.0000	0.0000	25.0000	25.0000	0.0000	25.0000	25.0000	0.0000
2	-33.3985	-0.4870	8.8735	3.0347	7.5363	26.4300	37.0011	60.2993	26.4300	86.7293	-99.0287
3	-25.7175	-0.3750	28.3381	9.6916	24.0677	39.2500	73.0093	192.5688	39.2500	231.8188	-316.2528
4	-18.8595	-0.2750	48.7186	16.6618	41.3769	52.7500	110.7887	331.0627	52.7500	383.8127	-543.6993
5	-12.6187	-0.1840	58.6798	20.0685	49.8371	66.8800	136.7856	398.7536	66.8800	465.6336	-654.8669
6	-12.0015	-0.1750	61.4278	21.0083	52.1709	68.5000	141.6792	417.4269	68.5000	485.9269	-685.5339
7	-1.9888	-0.0290	62.2293	21.2824	52.8516	81.2800	155.4140	422.8733	81.2800	341.5933	-694.4785
8	7.1323	0.1040	62.2293	21.2824	52.8516	81.2800	155.4140	422.8733	81.2800	341.5933	-694.4785
9	13.3045	0.1940	59.0806	20.2056	50.1774	65.0800	135.4630	401.4767	65.0800	336.3968	-659.3392
10	19.7510	0.2880	46.0851	15.7611	39.1403	50.8000	105.7015	313.1674	50.8000	262.3675	-514.3102
11	24.8945	0.3630	31.7730	10.8664	26.9850	40.8100	78.6613	215.9105	40.8100	175.1005	-354.5865
12	30.4495	0.4440	22.8994	7.8316	19.4486	31.1600	58.4402	155.6111	31.1600	124.4511	-255.5578
13	33.6728	0.4910	14.5984	4.9927	12.3985	25.9900	43.3811	99.2021	25.9900	73.2121	-162.9181
14	34.2900	0.5000	0.0000	0.0000	0.0000	25.0000	25.0000	0.0000	25.0000	-25.0000	0.0000

Vortex effect

I	YFS	YH	QFS	QJ	DV	DI	DT	LI	MM
1	-34.2900	-0.5000	0.0000	0.6000	0.2052	0.5096	0.7148	4.0772	-6.6960
2	-33.3985	-0.4870	8.8735	0.6600	3.2605	8.0969	11.3574	64.7843	-106.3943
3	-25.7175	-0.3750	28.3381	1.1400	10.0815	25.0359	35.1174	200.3156	-328.9752
4	-18.8595	-0.2750	48.7186	1.5500	17.1919	42.6934	59.8852	341.5956	-560.9973
5	-12.6187	-0.1840	58.6798	1.8300	20.6944	51.3913	72.0857	411.1892	-675.2898
6	-12.0015	-0.1750	61.4278	1.8500	21.6410	53.7421	75.3831	429.9984	-706.1799
7	-1.9888	-0.0290	62.2293	2.0000	21.9664	54.5502	76.5166	436.4641	-716.7985
8	7.1323	0.1040	62.2293	1.8800	21.9596	54.5332	76.4928	436.3282	-716.5753
9	13.3045	0.1940	59.0806	1.8100	20.8246	51.7147	72.5393	413.7764	-679.5388
10	19.7510	0.2880	46.0851	1.5000	16.2741	40.4143	56.6884	323.3606	-531.0502
11	24.8945	0.3630	31.7730	1.1800	11.2699	27.9871	39.2571	223.9291	-367.7553
12	30.4495	0.4440	22.8994	0.8500	8.1223	20.1705	28.2928	161.3873	-265.0439
13	33.6728	0.4910	14.5984	0.6600	5.2184	12.9590	18.1774	103.6871	-170.2837
14	34.2900	0.5000	0.0000	0.6000	0.2052	0.5096	0.7148	4.0772	-6.6960

Jet effect with turbofan A

I	YFS	YH	QFS	QJ	DV	DI	DT	LI	MM
1	-34.2900	-0.5000	0.0000	0.4300	0.1471	0.3652	0.5123	2.9220	-4.7988
2	-33.3985	-0.4870	8.8735	0.4700	3.1955	7.9355	11.1310	63.4932	-104.2739
3	-25.7175	-0.3750	28.3381	0.7500	9.9481	24.7046	34.6528	197.6653	-324.6228
4	-18.8595	-0.2750	48.7186	1.0000	17.0038	42.2262	59.2300	337.8581	-554.8593
5	-12.6187	-0.1840	58.6798	1.2300	20.4892	50.8817	71.3709	407.1119	-668.5938
6	-12.0015	-0.1750	61.4278	1.2500	21.4358	53.2326	74.6684	425.9212	-699.4839
7	-1.9888	-0.0290	62.2293	1.4000	21.7612	54.0407	75.8019	432.3869	-710.1025
8	7.1323	0.1040	62.2293	1.3800	21.7544	54.0237	75.7780	432.2510	-709.8793
9	13.3045	0.1940	59.0806	1.2000	20.6160	51.1966	71.8126	409.6312	-672.7312
10	19.7510	0.2880	46.0851	0.9600	16.0894	39.9557	56.0451	319.6910	-525.0238
11	24.8945	0.3630	31.7730	0.7700	11.1297	27.6389	38.7686	221.1429	-363.1797
12	30.4495	0.4440	22.8994	0.5800	8.0300	19.9412	27.9712	159.5525	-262.0306
13	33.6728	0.4910	14.5984	0.4600	5.1500	12.7892	17.9391	102.3280	-168.0517
14	34.2900	0.5000	0.0000	0.4300	0.1471	0.3652	0.5123	2.9220	-4.7988

Propeller effect.

(h) Tabulated data, $\epsilon_1 = -3.0^\circ$, $\epsilon_2 = -4.0^\circ$.

Figure 39.- Concluded.

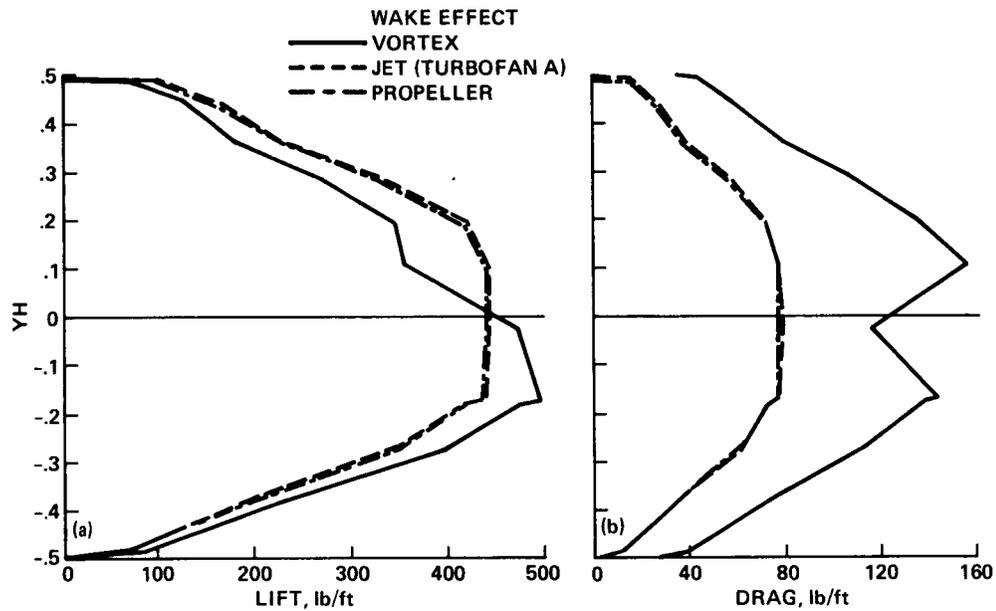

(a) $\epsilon_1 = 3.0^\circ$, $\epsilon_2 = 0^\circ$. (b) $\epsilon_1 = -3.0^\circ$, $\epsilon_2 = -4.0^\circ$.

Figure 40.- Comparison of maximum lift and drag with vortex and jet exhaust wake effects at vane set 1.

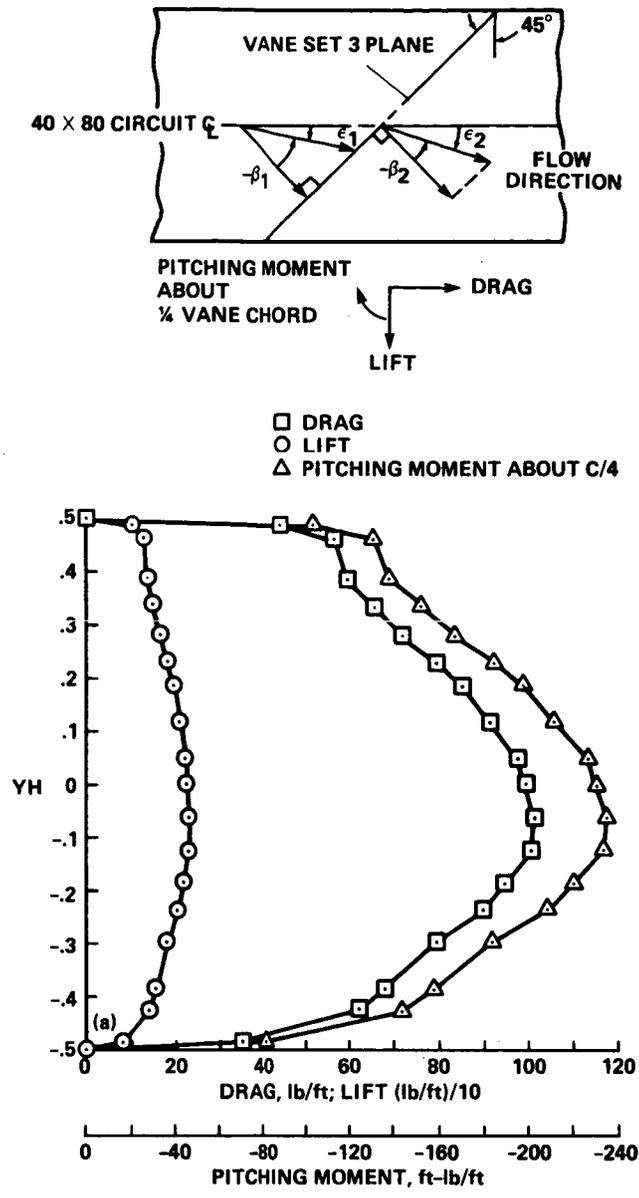

(a) 40 x 80 mode design load: $\epsilon_1 = 3.0$, $\epsilon_2 = 0^\circ$.

Figure 41.- Variation of estimated maximum local load with vane 3I span.

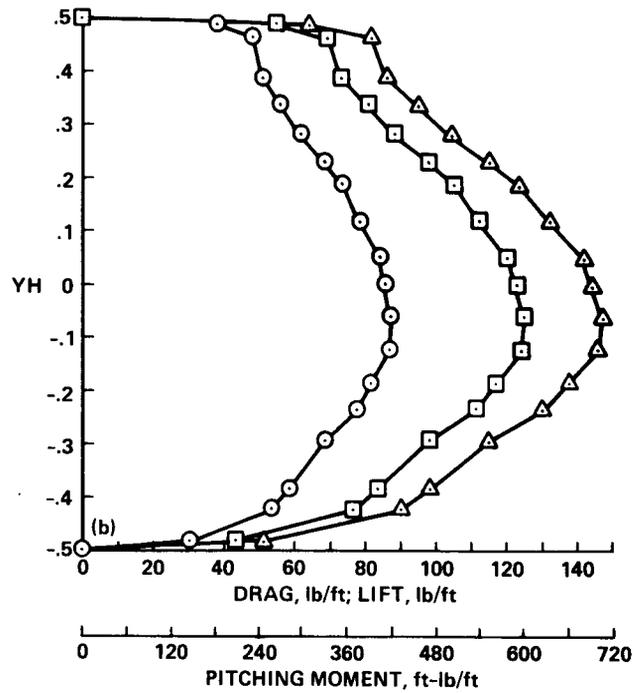

(b) 40 x 80 mode design load: $\epsilon_1 = -3.0^\circ$, $\epsilon_2 = 0^\circ$.

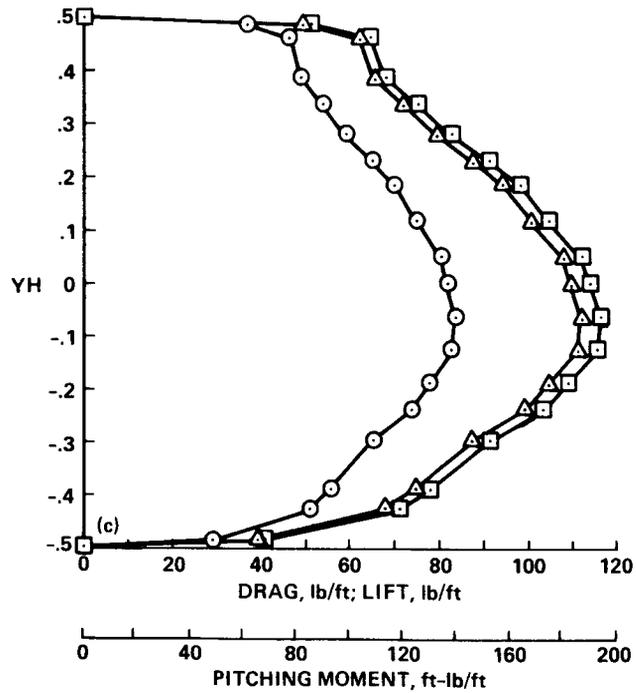

(c) 40 x 80 mode operating load: $\epsilon_1 = 0^\circ$, $\epsilon_2 = 0^\circ$.

Figure 41.- Continued.

DTRUSS(LB/FT)=DDTRUSS*QFS/HFS DDTRUSS= 39.3400		LTRUSS(LB/FT)=LLTRUSS*QFS/HFS LLTRUSS= 0.0000		MTRUSS(LB/FT)=MMTRUSS*QFS/HFS MMTRUSS= 221.0900		LJTRUSS = 0.0					
I	YFS	YH	QFS	DV	DI	DDT	DTRUSS	DT	LI	LLT	LT
1	-34.1350	-0.5000	0.0000	0.0000	0.0000	0.0000	0.0000	0.0000	0.0000	0.0000	0.0000
2	-33.1110	-0.4850	18.0711	37.0006	36.8345	24.7984	10.4133	35.2117	38.7649	79.6202	79.6202
3	-29.0147	-0.4250	31.9078	65.3312	65.0378	43.7860	18.3866	62.1725	68.4462	140.5836	140.5836
4	-26.4205	-0.3870	34.8898	71.4369	71.1161	47.8781	20.1050	67.9831	74.8431	153.7222	153.7222
5	-20.2079	-0.2960	40.8539	83.6483	83.2726	56.0624	23.5417	79.6041	87.6368	179.9995	179.9995
6	-16.1800	-0.2370	46.2216	94.6386	94.2136	63.4283	26.6348	90.0630	99.1511	203.6491	203.6491
7	-12.7665	-0.1870	48.7265	99.7674	99.3193	66.8657	28.0782	94.9439	104.5245	214.6856	214.6856
8	-8.5337	-0.1250	51.7681	105.9953	105.5192	71.0397	29.8309	100.8706	111.0492	228.0870	228.0870
9	-4.2327	-0.0620	52.1856	106.8501	106.3702	71.6125	30.0715	101.6841	111.9448	229.9264	229.9264
10	0.0000	0.0000	50.9928	104.4078	103.9389	69.9757	29.3842	99.3599	109.3860	224.6709	224.6709
11	3.4135	0.0500	50.2175	102.8203	102.3585	68.9117	28.9374	97.8491	107.7229	221.2549	221.2549
12	8.1241	0.1190	46.8180	95.8598	95.4292	64.2467	26.9784	91.2252	100.4305	206.2768	206.2768
13	12.8348	0.1880	43.8359	89.7541	89.3509	60.1545	25.2601	85.4146	94.0336	193.1382	193.1382
14	15.7704	0.2310	40.8539	83.6483	83.2726	56.0624	23.5417	79.6041	87.6368	179.9995	179.9995
15	19.1839	0.2810	36.9772	75.7109	75.3709	50.7426	21.3078	72.0504	79.3209	162.9193	162.9193
16	23.0753	0.3380	33.6970	68.9946	68.6847	46.2412	19.4176	65.6589	72.2843	148.4667	148.4667
17	26.4888	0.3880	30.5957	62.6447	62.3633	41.9854	17.6305	59.6159	65.6316	134.8026	134.8026
18	31.6090	0.4630	29.0450	59.4697	59.2026	39.8575	16.7369	56.5944	62.3053	127.9705	127.9705
19	33.3158	0.4880	22.9617	47.0140	46.8029	31.5095	13.2315	44.7410	49.2557	101.1676	101.1676
20	34.1350	0.5000	0.0000	0.0000	0.0000	0.0000	0.0000	0.0000	0.0000	0.0000	0.0000

DTRUSS(LB/FT)=DDTRUSS*QFS/HFS DDTRUSS= 39.3400		LTRUSS(LB/FT)=LLTRUSS*QFS/HFS LLTRUSS= 0.0000		MTRUSS(LB/FT)=MMTRUSS*QFS/HFS MMTRUSS= 221.0900		LJTRUSS = 0.0					
I	YFS	YH	QFS	DV	DI	DDT	DTRUSS	DT	LI	LLT	LT
1	-34.1350	-0.5000	0.0000	0.0000	0.0000	0.0000	0.0000	0.0000	0.0000	0.0000	0.0000
2	-33.1110	-0.4850	18.0711	37.0006	36.8345	24.7984	10.4133	35.2117	38.7649	79.6202	79.6202
3	-29.0147	-0.4250	31.9078	65.3312	65.0378	43.7860	18.3866	62.1725	68.4462	140.5836	140.5836
4	-26.4205	-0.3870	34.8898	71.4369	71.1161	47.8781	20.1050	67.9831	74.8431	153.7222	153.7222
5	-20.2079	-0.2960	40.8539	83.6483	83.2726	56.0624	23.5417	79.6041	87.6368	179.9995	179.9995
6	-16.1800	-0.2370	46.2216	94.6386	94.2136	63.4283	26.6348	90.0630	99.1511	203.6491	203.6491
7	-12.7665	-0.1870	48.7265	99.7674	99.3193	66.8657	28.0782	94.9439	104.5245	214.6856	214.6856
8	-8.5337	-0.1250	51.7681	105.9953	105.5192	71.0397	29.8309	100.8706	111.0492	228.0870	228.0870
9	-4.2327	-0.0620	52.1856	106.8501	106.3702	71.6125	30.0715	101.6841	111.9448	229.9264	229.9264
10	0.0000	0.0000	50.9928	104.4078	103.9389	69.9757	29.3842	99.3599	109.3860	224.6709	224.6709
11	3.4135	0.0500	50.2175	102.8203	102.3585	68.9117	28.9374	97.8491	107.7229	221.2549	221.2549
12	8.1241	0.1190	46.8180	95.8598	95.4292	64.2467	26.9784	91.2252	100.4305	206.2768	206.2768
13	12.8348	0.1880	43.8359	89.7541	89.3509	60.1545	25.2601	85.4146	94.0336	193.1382	193.1382
14	15.7704	0.2310	40.8539	83.6483	83.2726	56.0624	23.5417	79.6041	87.6368	179.9995	179.9995
15	19.1839	0.2810	36.9772	75.7109	75.3709	50.7426	21.3078	72.0504	79.3209	162.9193	162.9193
16	23.0753	0.3380	33.6970	68.9946	68.6847	46.2412	19.4176	65.6589	72.2843	148.4667	148.4667
17	26.4888	0.3880	30.5957	62.6447	62.3633	41.9854	17.6305	59.6159	65.6316	134.8026	134.8026
18	31.6090	0.4630	29.0450	59.4697	59.2026	39.8575	16.7369	56.5944	62.3053	127.9705	127.9705
19	33.3158	0.4880	22.9617	47.0140	46.8029	31.5095	13.2315	44.7410	49.2557	101.1676	101.1676
20	34.1350	0.5000	0.0000	0.0000	0.0000	0.0000	0.0000	0.0000	0.0000	0.0000	0.0000

(d) 40 x 80 mode local design load tabulated data, $\epsilon_1 = 3.0^\circ$, $\epsilon_2 = 0^\circ$.

Figure 41.- Continued.

DTRUSS(LB/FT)=DDTRUSS*QFS/HFS DDTRUSS= 39.3400		LTRUSS(LB/FT)=LLTRUSS*QFS/HFS LLTRUSS= 0.0000		MTRUSS=MMTRUSS*QFS/HFS MMTRUSS= 221.0900							
I	YFS	YH	QFS	DV	DI	DDT	DTRUSS	DT	LI	LLT	LT
1	-34.1350	-0.5000	0.0000	0.0000	0.0000	0.0000	0.0000	0.0000	0.0000	0.0000	0.0000
2	-33.1110	-0.4850	22.2900	45.6388	-45.4339	30.5878	12.8444	43.4323	-43.0528	-30.2980	-30.2980
3	-29.0147	-0.4250	39.3570	80.5834	-80.2215	54.0082	22.6791	76.6873	-76.0173	-53.4965	-53.4965
4	-26.4205	-0.3870	43.0352	88.1146	-87.7189	59.0557	24.7987	83.8544	-83.1217	-58.4961	-58.4961
5	-20.2079	-0.2960	50.3916	103.1769	-102.7136	69.1507	29.0378	98.1885	-97.3306	-68.4955	-68.4955
6	-16.1800	-0.2370	57.0124	116.7330	-116.2088	78.2362	32.8529	111.0891	-110.1185	-77.4949	-77.4949
7	-12.7665	-0.1870	60.1021	123.0591	-122.5065	82.4761	34.6334	117.1095	-116.0862	-81.6946	-81.6946
8	-8.5337	-0.1250	63.8539	130.7409	-130.1538	87.6246	36.7953	124.4198	-123.3327	-86.7943	-86.7943
9	-4.2327	-0.0620	64.3689	131.7953	-131.2035	88.3312	37.0920	125.4232	-124.3274	-87.4942	-87.4942
10	0.0000	0.0000	62.8976	128.7828	-128.2045	86.3122	36.2442	122.5564	-121.4856	-85.4944	-85.4944
11	3.4135	0.0500	61.9413	126.8247	-126.2552	84.9999	35.6931	120.6930	-119.6384	-84.1945	-84.1945
12	8.1241	0.1190	57.7481	118.2392	-117.7082	79.2457	33.2768	112.5225	-111.5394	-78.4948	-78.4948
13	12.8348	0.1880	54.0699	110.7080	-110.2109	74.1982	31.1573	105.3555	-104.4350	-73.4951	-73.4951
14	15.7704	0.2310	50.3916	103.1769	-102.7136	69.1507	29.0378	98.1885	-97.3306	-68.4955	-68.4955
15	19.1839	0.2810	45.6100	93.3864	-92.9670	62.5890	26.2823	88.8713	-88.0948	-61.9959	-61.9959
16	23.0753	0.3380	41.5639	85.1021	-84.7199	57.0367	23.9508	80.9876	-80.2799	-56.4963	-56.4963
17	26.4888	0.3880	37.7386	77.2697	-76.9227	51.7873	21.7465	73.5338	-72.8913	-51.2966	-51.2966
18	31.6090	0.4630	35.8259	73.3535	-73.0241	49.1626	20.6444	69.8070	-69.1971	-48.6968	-48.6968
19	33.3158	0.4880	28.3223	57.9899	-57.7295	38.8657	16.3205	55.1862	-54.7040	-38.4975	-38.4975
20	34.1350	0.5000	0.0000	0.0000	0.0000	0.0000	0.0000	0.0000	0.0000	0.0000	0.0000

		MTRUSS		MM		MT		LJTRUSS = 0.0	
I	YFS	YH	QFS	MM	MTRUSS	MT			
1	-34.1350	-0.5000	0.0000	0.0000	0.0000	0.0000			
2	-33.1110	-0.4850	22.2900	172.8092	72.1855	244.9947			
3	-29.0147	-0.4250	39.3570	305.1252	127.4562	432.5815			
4	-26.4205	-0.3870	43.0352	333.6416	139.3680	473.0096			
5	-20.2079	-0.2960	50.3916	390.6743	163.1916	553.8659			
6	-16.1800	-0.2370	57.0124	442.0038	184.6328	626.6367			
7	-12.7665	-0.1870	60.1021	465.9576	194.6387	660.5963			
8	-8.5337	-0.1250	63.8539	495.0443	206.7887	701.8330			
9	-4.2327	-0.0620	64.3689	499.0366	208.4564	707.4930			
10	0.0000	0.0000	62.8976	487.6300	203.6917	691.3217			
11	3.4135	0.0500	61.9413	480.2158	200.5946	680.8104			
12	8.1241	0.1190	57.7481	447.7071	187.0152	634.7222			
13	12.8348	0.1880	54.0699	419.1907	175.1034	594.2941			
14	15.7704	0.2310	50.3916	390.6743	163.1916	553.8659			
15	19.1839	0.2810	45.6100	353.6031	147.7062	501.3093			
16	23.0753	0.3380	41.5639	322.2350	134.6033	456.8383			
17	26.4888	0.3880	37.7386	292.5780	122.2150	414.7930			
18	31.6090	0.4630	35.8259	277.7495	116.0209	393.7704			
19	33.3158	0.4880	28.3223	219.5761	91.7208	311.2969			
20	34.1350	0.5000	0.0000	0.0000	0.0000	0.0000			

(e) 40 x 80 mode local design load tabulated data, $\epsilon = -3.0^\circ$, $\epsilon_2 = 0^\circ$.

Figure 41.- Continued.

ORIGINAL PAGE IS
OF POOR QUALITY

DTRUSS(LB/FT)=DDTRUSS*QFS/HFS LTRUSS(LB/FT)=LLTRUSS*QFS/HFS MTRUSS=MMTRUSS*QFS/HFS
DDTRUSS= 39.3400 LLTRUSS= 0.0000 MMTRUSS= 221.0900

LOCAL Q(LB/FT2)= QFS VANE HEIGHT(FT) =YFS

I	YFS	YH	QFS	DV	DDT	DTRUSS	DT	LLT	LT
1	-34.1350	-0.5000	0.0000	0.0000	0.0000	0.0000	0.0000	0.0000	0.0000
2	-33.1110	-0.4850	19.9601	40.8683	28.8982	11.5018	40.4001	28.8982	28.8982
3	-29.0147	-0.4250	35.2431	72.1602	51.0249	20.3085	71.3335	51.0249	51.0249
4	-26.4205	-0.3870	38.5368	78.9041	55.7936	22.2065	78.0001	55.7936	55.7936
5	-20.2079	-0.2960	45.1243	92.3920	65.3310	26.0025	91.3335	65.3310	65.3310
6	-16.1800	-0.2370	51.0530	104.5311	73.9146	29.4189	103.3335	73.9146	73.9146
7	-12.7665	-0.1870	53.8198	110.1960	77.9203	31.0132	108.9335	77.9203	77.9203
8	-8.5337	-0.1250	57.1794	117.0748	82.7844	32.9491	115.7335	82.7844	82.7844
9	-4.2327	-0.0620	57.6405	118.0189	83.4520	33.2148	116.6668	83.4520	83.4520
10	0.0000	0.0000	56.3230	115.3214	81.5445	32.4557	114.0002	81.5445	81.5445
11	3.4135	0.0500	55.4666	113.5679	80.3047	31.9622	112.2668	80.3047	80.3047
12	8.1241	0.1190	51.7118	105.8799	74.8684	29.7985	104.6668	74.8684	74.8684
13	12.8348	0.1880	48.4180	99.1359	70.0997	27.9005	98.0001	70.0997	70.0997
14	15.7704	0.2310	45.1243	92.3920	65.3310	26.0025	91.3335	65.3310	65.3310
15	19.1839	0.2810	40.8424	83.6248	59.1317	23.5351	82.6668	59.1317	59.1317
16	23.0753	0.3380	37.2193	76.2065	53.8861	21.4473	75.3334	53.8861	53.8861
17	26.4888	0.3880	33.7938	69.1928	48.9267	19.4734	68.4001	48.9267	48.9267
18	31.6090	0.4630	32.0811	65.6860	46.4470	18.4864	64.9334	46.4470	46.4470
19	33.3158	0.4880	25.3618	51.9283	36.7189	14.6145	51.3334	36.7189	36.7189
20	34.1350	0.5000	0.0000	0.0000	0.0000	0.0000	0.0000	0.0000	0.0000

I	YFS	YH	QFS	MM	MTRUSS	MT	DI = LI = LTRUSS = 0.0
1	-34.1350	-0.5000	0.0000	0.0000	0.0000	0.0000	
2	-33.1110	-0.4850	19.9601	0.0000	64.6400	64.6400	
3	-29.0147	-0.4250	35.2431	0.0000	114.1334	114.1334	
4	-26.4205	-0.3870	38.5368	0.0000	124.8001	124.8001	
5	-20.2079	-0.2960	45.1243	0.0000	146.1334	146.1334	
6	-16.1800	-0.2370	51.0530	0.0000	165.3334	165.3334	
7	-12.7665	-0.1870	53.8198	0.0000	174.2934	174.2934	
8	-8.5337	-0.1250	57.1794	0.0000	185.1734	185.1734	
9	-4.2327	-0.0620	57.6405	0.0000	186.6668	186.6668	
10	0.0000	0.0000	56.3230	0.0000	182.4001	182.4001	
11	3.4135	0.0500	55.4666	0.0000	179.6268	179.6268	
12	8.1241	0.1190	51.7118	0.0000	167.4668	167.4668	
13	12.8348	0.1880	48.4180	0.0000	156.8001	156.8001	
14	15.7704	0.2310	45.1243	0.0000	146.1334	146.1334	
15	19.1839	0.2810	40.8424	0.0000	132.2668	132.2668	
16	23.0753	0.3380	37.2193	0.0000	120.5334	120.5334	
17	26.4888	0.3880	33.7938	0.0000	109.4401	109.4401	
18	31.6090	0.4630	32.0811	0.0000	103.8934	103.8934	
19	33.3158	0.4880	25.3618	0.0000	82.1334	82.1334	
20	34.1350	0.5000	0.0000	0.0000	0.0000	0.0000	

(f) 40 x 80 mode local operating load tabulated data, $\epsilon_1 = 0^\circ$, $\epsilon_2 = 0^\circ$.

Figure 41.- Continued.

NOTE: LOAD AND MOMENT DIRECTION SHOWN POSITIVE

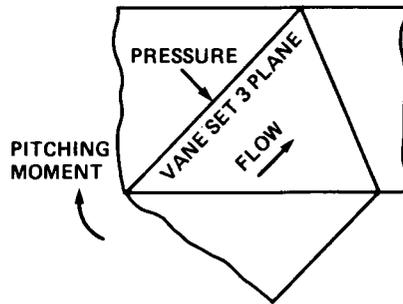

WALL PRESSURE DIFFERENTIAL, $(P_{ATM} - P_{STATIC})$ lb/ft ²	TRUSS		
	DRAG lb/ft	PITCHING MOMENT, ft-lb/ft	MOMENT ARM FROM VANE, ft
62	21	-119	5.62

(g) 80 x 120 mode load.

Figure 41.- Concluded.

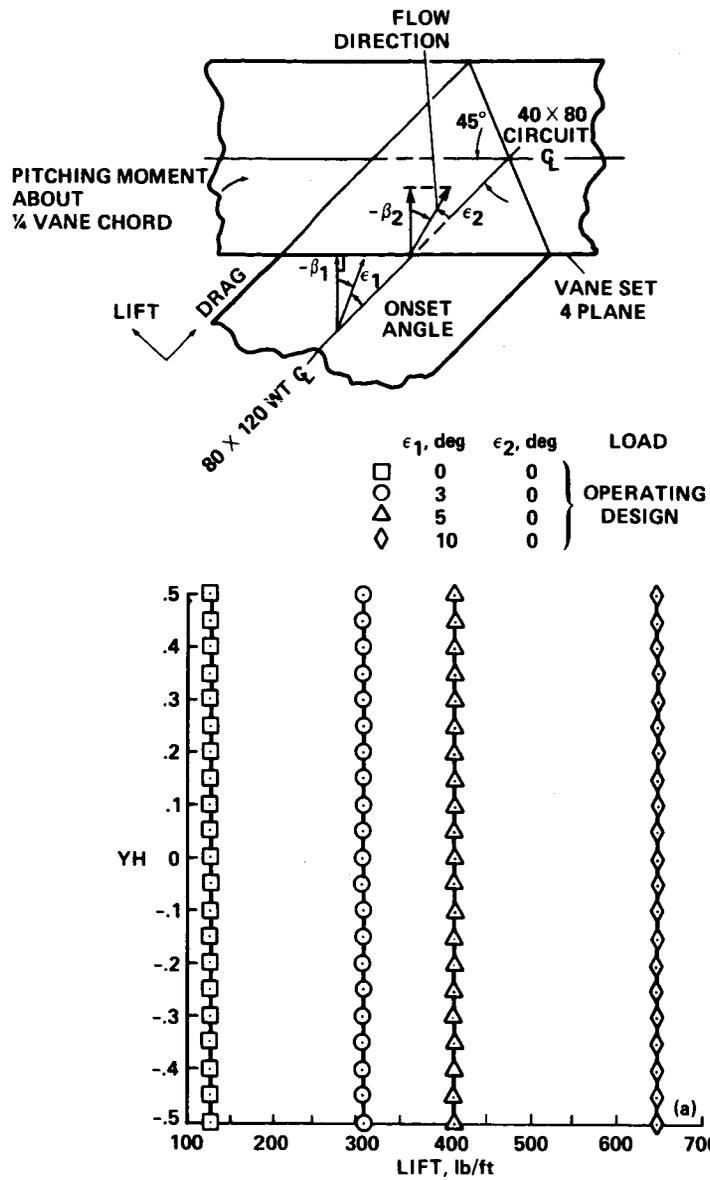

(a) Lift without vortex-, jet-, or propeller-wake effects.

Figure 42.- Spanwise vane loads of vane set 4; 80 x 120 mode.

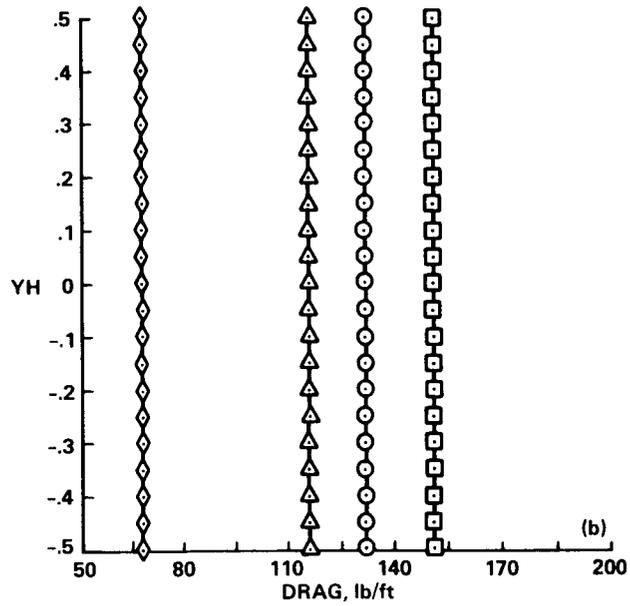

(b) Drag without vortex-, jet-, or propeller-wake effects.

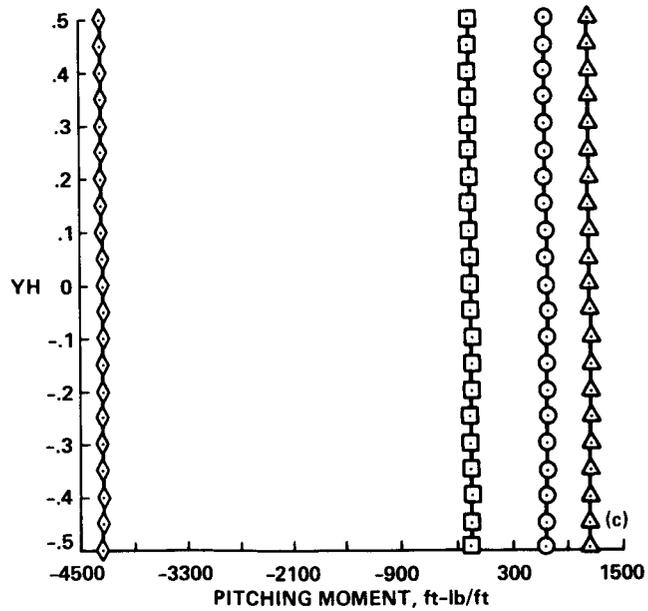

(c) Pitching moment about $1/4 c$ without vortex-, jet-, or propeller-wake effects.

Figure 42.- Continued.

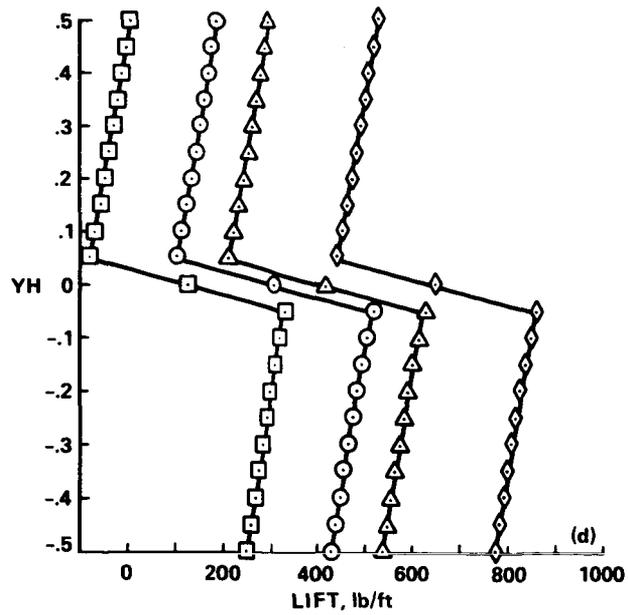

(d) Lift with vortex-wake center at vane-set centerline.

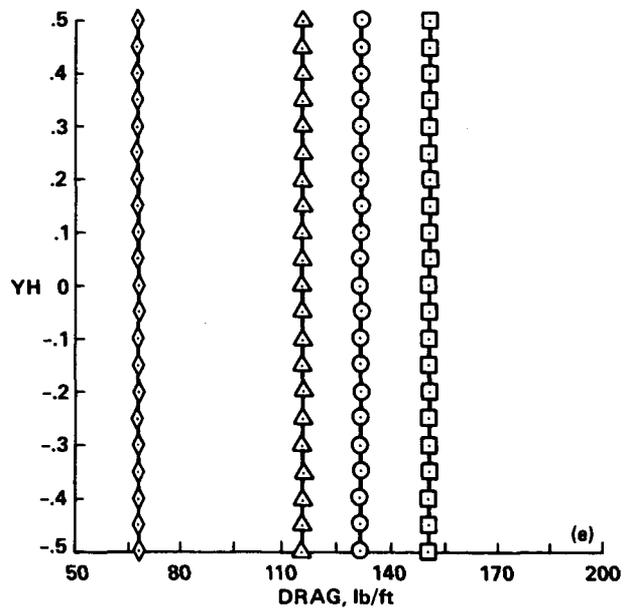

(e) Drag with vortex wake center at vane-set centerline.

Figure 42.- Continued.

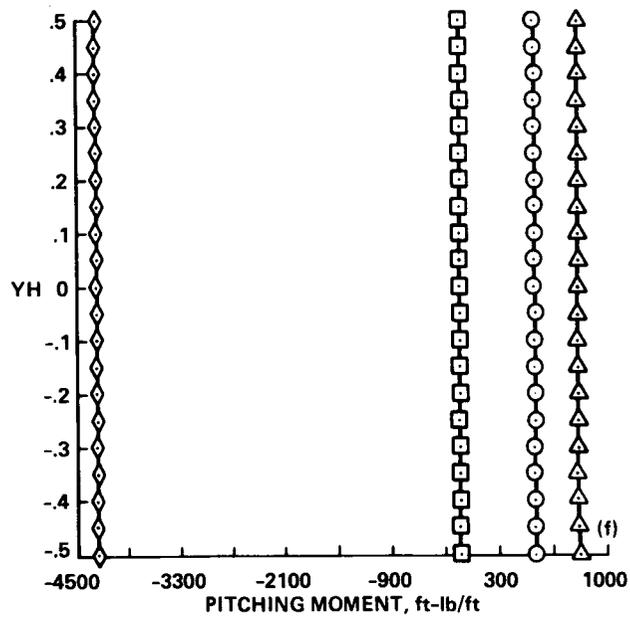

(f) Pitching moment with vortex-wake center at vane-set centerline.

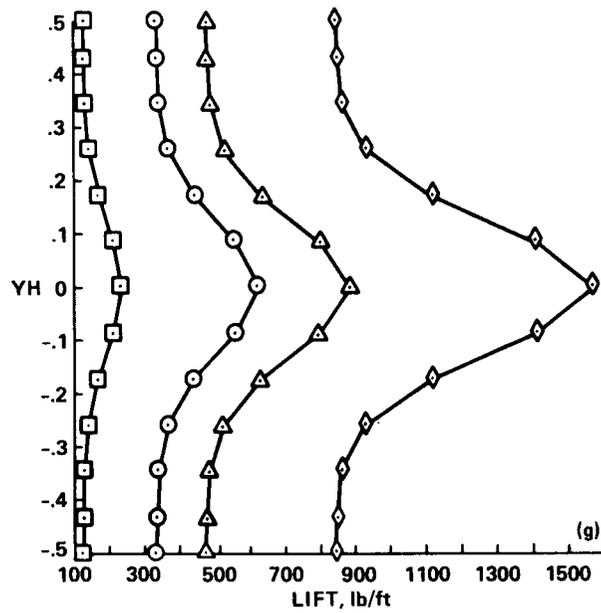

(g) Lift with jet-wake center of turbofan engine A at vane midspan.

Figure 42.- Continued.

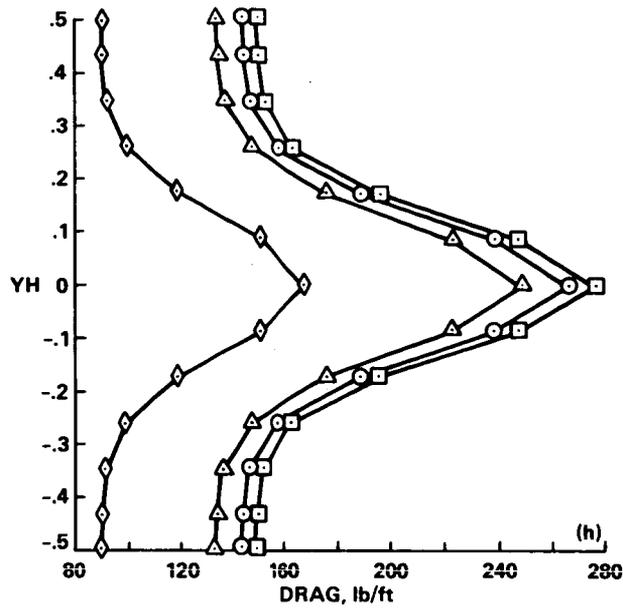

(h) Drag with jet-wake center of turbofan engine A at vane midspan.

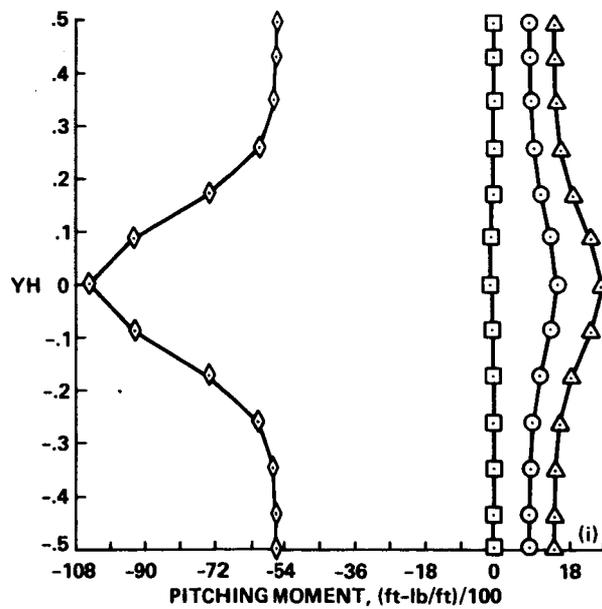

(i) Pitching moment about $1/4$ c with jet-wake center of turbofan engine A at vane midspan.

Figure 42.- Continued.

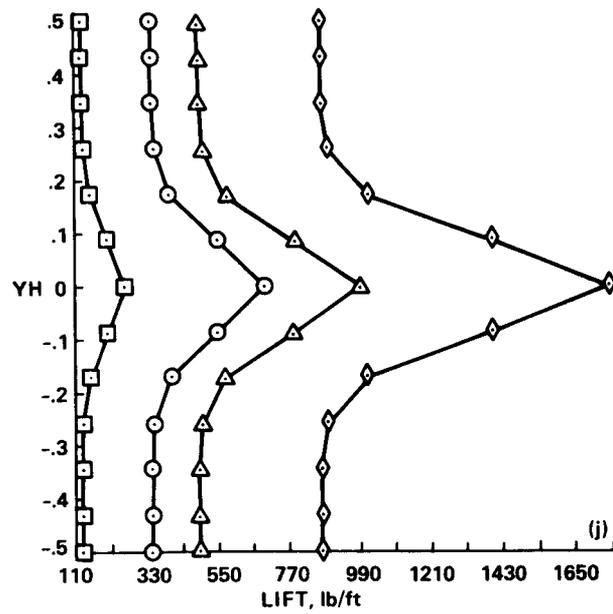

(j) Lift with propeller-wake center at vane midspan.

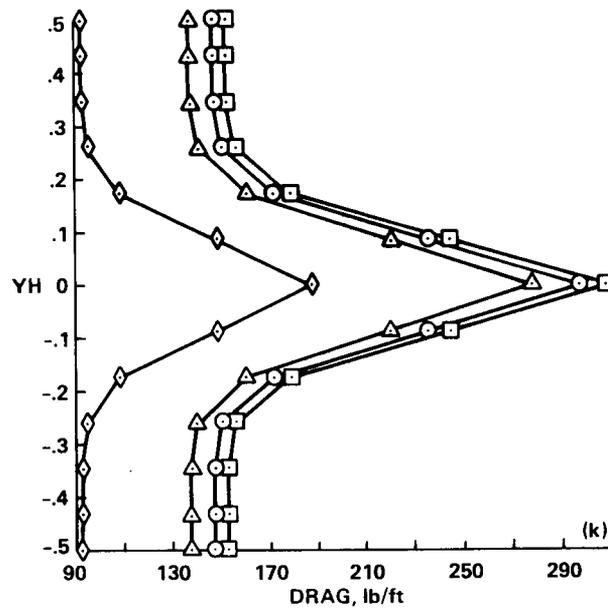

(k) Drag with propeller-wake center at vane midspan.

Figure 42.- Continued.

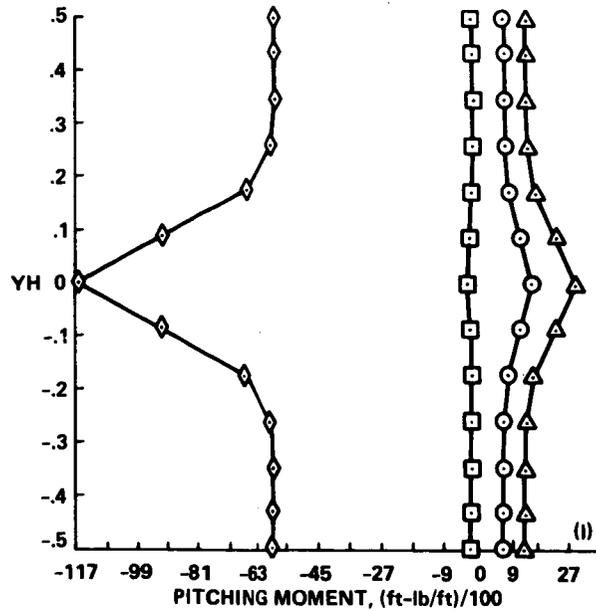

(1) Pitching moment about 1/4 c with propeller-wake center at vane midspan.

Figure 42.- Continued.

LOADS DUE TO TRUSSES
 DTRUSS(LB/FT)= 23.7890 LTRUSS(LB/FT)= 0.0000 MTRUSS(FT-LB/FT)= -133.6935

QFS = DI = DVOR = LI = LVOR = MVOR = MM = 0.0

I	YFS	YH	DV	DDT	DT	LLT	LT	MT
1	-34.6700	-0.5000	179.6319	127.0189	150.8079	127.0189	127.0189	-133.6935
2	-31.2030	-0.4500	179.6319	127.0189	150.8079	127.0189	127.0189	-133.6935
3	-27.7360	-0.4000	179.6319	127.0189	150.8079	127.0189	127.0189	-133.6935
4	-24.2690	-0.3500	179.6319	127.0189	150.8079	127.0189	127.0189	-133.6935
5	-20.8020	-0.3000	179.6319	127.0189	150.8079	127.0189	127.0189	-133.6935
6	-17.3350	-0.2500	179.6319	127.0189	150.8079	127.0189	127.0189	-133.6935
7	-13.8680	-0.2000	179.6319	127.0189	150.8079	127.0189	127.0189	-133.6935
8	-10.4010	-0.1500	179.6319	127.0189	150.8079	127.0189	127.0189	-133.6935
9	-6.9340	-0.1000	179.6319	127.0189	150.8079	127.0189	127.0189	-133.6935
10	-3.4670	-0.0500	179.6319	127.0189	150.8079	127.0189	127.0189	-133.6935
11	0.0000	0.0000	179.6319	127.0189	150.8079	127.0189	127.0189	-133.6935
12	3.4670	0.0500	179.6319	127.0189	150.8079	127.0189	127.0189	-133.6935
13	6.9340	0.1000	179.6319	127.0189	150.8079	127.0189	127.0189	-133.6935
14	10.4010	0.1500	179.6319	127.0189	150.8079	127.0189	127.0189	-133.6935
15	13.8680	0.2000	179.6319	127.0189	150.8079	127.0189	127.0189	-133.6935
16	17.3350	0.2500	179.6319	127.0189	150.8079	127.0189	127.0189	-133.6935
17	20.8020	0.3000	179.6319	127.0189	150.8079	127.0189	127.0189	-133.6935
18	24.2690	0.3500	179.6319	127.0189	150.8079	127.0189	127.0189	-133.6935
19	27.7360	0.4000	179.6319	127.0189	150.8079	127.0189	127.0189	-133.6935
20	31.2030	0.4500	179.6319	127.0189	150.8079	127.0189	127.0189	-133.6935
21	34.6700	0.5000	179.6319	127.0189	150.8079	127.0189	127.0189	-133.6935

(m) Tabulated data without vortex-, jet-, or propeller-wake effects:
 $\epsilon_1 = 0^\circ$, $\epsilon_2 = 0^\circ$.

Figure 42.- Continued.

DTRUSS(LB/FT) = 21.5366 LTRUSS(LB/FT) = 0.0000 MTRUSS(FT-LB/FT) = -121.0351
 QFS = DVOR = LVOR = MVOR = 0.0

I	YFS	YH	DV	DI	DOT	DT	LI	LLT	LT
1	-34.6700	-0.5000	162.6240	131.7739	110.1093	131.6459	138.6799	306.2323	306.2323
2	-31.2030	-0.4500	162.6240	131.7739	110.1093	131.6459	138.6799	306.2323	306.2323
3	-27.7360	-0.4000	162.6240	131.7739	110.1093	131.6459	138.6799	306.2323	306.2323
4	-24.2690	-0.3500	162.6240	131.7739	110.1093	131.6459	138.6799	306.2323	306.2323
5	-20.8020	-0.3000	162.6240	131.7739	110.1093	131.6459	138.6799	306.2323	306.2323
6	-17.3350	-0.2500	162.6240	131.7739	110.1093	131.6459	138.6799	306.2323	306.2323
7	-13.8680	-0.2000	162.6240	131.7739	110.1093	131.6459	138.6799	306.2323	306.2323
8	-10.4010	-0.1500	162.6240	131.7739	110.1093	131.6459	138.6799	306.2323	306.2323
9	-6.9340	-0.1000	162.6240	131.7739	110.1093	131.6459	138.6799	306.2323	306.2323
10	-3.4670	-0.0500	162.6240	131.7739	110.1093	131.6459	138.6799	306.2323	306.2323
11	0.0000	0.0000	162.6240	131.7739	110.1093	131.6459	138.6799	306.2323	306.2323
12	3.4670	0.0500	162.6240	131.7739	110.1093	131.6459	138.6799	306.2323	306.2323
13	6.9340	0.1000	162.6240	131.7739	110.1093	131.6459	138.6799	306.2323	306.2323
14	10.4010	0.1500	162.6240	131.7739	110.1093	131.6459	138.6799	306.2323	306.2323
15	13.8680	0.2000	162.6240	131.7739	110.1093	131.6459	138.6799	306.2323	306.2323
16	17.3350	0.2500	162.6240	131.7739	110.1093	131.6459	138.6799	306.2323	306.2323
17	20.8020	0.3000	162.6240	131.7739	110.1093	131.6459	138.6799	306.2323	306.2323
18	24.2690	0.3500	162.6240	131.7739	110.1093	131.6459	138.6799	306.2323	306.2323
19	27.7360	0.4000	162.6240	131.7739	110.1093	131.6459	138.6799	306.2323	306.2323
20	31.2030	0.4500	162.6240	131.7739	110.1093	131.6459	138.6799	306.2323	306.2323
21	34.6700	0.5000	162.6240	131.7739	110.1093	131.6459	138.6799	306.2323	306.2323

I	YHS	YH	MM	MT
1	-34.6700	-0.5000	829.3452	708.3101
2	-31.2030	-0.4500	829.3452	708.3101
3	-27.7360	-0.4000	829.3452	708.3101
4	-24.2690	-0.3500	829.3452	708.3101
5	-20.8020	-0.3000	829.3452	708.3101
6	-17.3350	-0.2500	829.3452	708.3101
7	-13.8680	-0.2000	829.3452	708.3101
8	-10.4010	-0.1500	829.3452	708.3101
9	-6.9340	-0.1000	829.3452	708.3101
10	-3.4670	-0.0500	829.3452	708.3101
11	0.0000	0.0000	829.3452	708.3101
12	3.4670	0.0500	829.3452	708.3101
13	6.9340	0.1000	829.3452	708.3101
14	10.4010	0.1500	829.3452	708.3101
15	13.8680	0.2000	829.3452	708.3101
16	17.3350	0.2500	829.3452	708.3101
17	20.8020	0.3000	829.3452	708.3101
18	24.2690	0.3500	829.3452	708.3101
19	27.7360	0.4000	829.3452	708.3101
20	31.2030	0.4500	829.3452	708.3101
21	34.6700	0.5000	829.3452	708.3101

(n) Tabulated data without vortex-, jet-, or propeller-wake effects:
 $\epsilon_1 = 3.0^\circ$, $\epsilon_2 = 0^\circ$.

Figure 42.- Continued.

MTRUSS(FT-LB/FT) = -113.8929

DTRUSS(LB/FT) = 20.2657 LTRUSS(LB/FT) = 0.0000 DDT DI DV DDI DT LI LLT LT

QFS = DVOR = LVOR = MVOR = 0.0 0.0000

I	YFS	YH	DV	DI	DDT	DT	LI	LLT	LT
1	-34.6700	-0.5000	153.0277	205.9921	95.4635	115.7292	224.0140	412.2672	412.2672
2	-31.2030	-0.4500	153.0277	205.9921	95.4635	115.7292	224.0140	412.2672	412.2672
3	-27.7360	-0.4000	153.0277	205.9921	95.4635	115.7292	224.0140	412.2672	412.2672
4	-24.2690	-0.3500	153.0277	205.9921	95.4635	115.7292	224.0140	412.2672	412.2672
5	-20.8020	-0.3000	153.0277	205.9921	95.4635	115.7292	224.0140	412.2672	412.2672
6	-17.3350	-0.2500	153.0277	205.9921	95.4635	115.7292	224.0140	412.2672	412.2672
7	-13.8680	-0.2000	153.0277	205.9921	95.4635	115.7292	224.0140	412.2672	412.2672
8	-10.4010	-0.1500	153.0277	205.9921	95.4635	115.7292	224.0140	412.2672	412.2672
9	-6.9340	-0.1000	153.0277	205.9921	95.4635	115.7292	224.0140	412.2672	412.2672
10	-3.4670	-0.0500	153.0277	205.9921	95.4635	115.7292	224.0140	412.2672	412.2672
11	0.0000	0.0000	153.0277	205.9921	95.4635	115.7292	224.0140	412.2672	412.2672
12	3.4670	0.0500	153.0277	205.9921	95.4635	115.7292	224.0140	412.2672	412.2672
13	6.9340	0.1000	153.0277	205.9921	95.4635	115.7292	224.0140	412.2672	412.2672
14	10.4010	0.1500	153.0277	205.9921	95.4635	115.7292	224.0140	412.2672	412.2672
15	13.8680	0.2000	153.0277	205.9921	95.4635	115.7292	224.0140	412.2672	412.2672
16	17.3350	0.2500	153.0277	205.9921	95.4635	115.7292	224.0140	412.2672	412.2672
17	20.8020	0.3000	153.0277	205.9921	95.4635	115.7292	224.0140	412.2672	412.2672
18	24.2690	0.3500	153.0277	205.9921	95.4635	115.7292	224.0140	412.2672	412.2672
19	27.7360	0.4000	153.0277	205.9921	95.4635	115.7292	224.0140	412.2672	412.2672
20	31.2030	0.4500	153.0277	205.9921	95.4635	115.7292	224.0140	412.2672	412.2672
21	34.6700	0.5000	153.0277	205.9921	95.4635	115.7292	224.0140	412.2672	412.2672

MM MT

I	YHS	YH	MM	MT
1	-34.6700	-0.5000	1314.3682	1200.4752
2	-31.2030	-0.4500	1314.3682	1200.4752
3	-27.7360	-0.4000	1314.3682	1200.4752
4	-24.2690	-0.3500	1314.3682	1200.4752
5	-20.8020	-0.3000	1314.3682	1200.4752
6	-17.3350	-0.2500	1314.3682	1200.4752
7	-13.8680	-0.2000	1314.3682	1200.4752
8	-10.4010	-0.1500	1314.3682	1200.4752
9	-6.9340	-0.1000	1314.3682	1200.4752
10	-3.4670	-0.0500	1314.3682	1200.4752
11	0.0000	0.0000	1314.3682	1200.4752
12	3.4670	0.0500	1314.3682	1200.4752
13	6.9340	0.1000	1314.3682	1200.4752
14	10.4010	0.1500	1314.3682	1200.4752
15	13.8680	0.2000	1314.3682	1200.4752
16	17.3350	0.2500	1314.3682	1200.4752
17	20.8020	0.3000	1314.3682	1200.4752
18	24.2690	0.3500	1314.3682	1200.4752
19	27.7360	0.4000	1314.3682	1200.4752
20	31.2030	0.4500	1314.3682	1200.4752
21	34.6700	0.5000	1314.3682	1200.4752

(o) Tabulated data without vortex-, jet-, or propeller-wake effects:
 $\epsilon_1 = 5.0^\circ$, $\epsilon_2 = 0^\circ$.

Figure 42.- Continued.

DTRUSS(LB/FT)= 17.7240 LTRUSS(LB/FT)= 0.0000 MTRUSS(FT-LB/FT)= -99.6085
 QFS = DVOR = LVOR = MVOR = 0.0

I	YFS	YH	DV	DI	DDT	DT	LI	LLT	LT
1	-34.6700	-0.5000	133.8350	354.8391	50.3936	68.1175	417.4068	640.6959	640.6959
2	-31.2030	-0.4500	133.8350	354.8391	50.3936	68.1175	417.4068	640.6959	640.6959
3	-27.7360	-0.4000	133.8350	354.8391	50.3936	68.1175	417.4068	640.6959	640.6959
4	-24.2690	-0.3500	133.8350	354.8391	50.3936	68.1175	417.4068	640.6959	640.6959
5	-20.8020	-0.3000	133.8350	354.8391	50.3936	68.1175	417.4068	640.6959	640.6959
6	-17.3350	-0.2500	133.8350	354.8391	50.3936	68.1175	417.4068	640.6959	640.6959
7	-13.8680	-0.2000	133.8350	354.8391	50.3936	68.1175	417.4068	640.6959	640.6959
8	-10.4010	-0.1500	133.8350	354.8391	50.3936	68.1175	417.4068	640.6959	640.6959
9	-6.9340	-0.1000	133.8350	354.8391	50.3936	68.1175	417.4068	640.6959	640.6959
10	-3.4670	-0.0500	133.8350	354.8391	50.3936	68.1175	417.4068	640.6959	640.6959
11	0.0000	0.0000	133.8350	354.8391	50.3936	68.1175	417.4068	640.6959	640.6959
12	3.4670	0.0500	133.8350	354.8391	50.3936	68.1175	417.4068	640.6959	640.6959
13	6.9340	0.1000	133.8350	354.8391	50.3936	68.1175	417.4068	640.6959	640.6959
14	10.4010	0.1500	133.8350	354.8391	50.3936	68.1175	417.4068	640.6959	640.6959
15	13.8680	0.2000	133.8350	354.8391	50.3936	68.1175	417.4068	640.6959	640.6959
16	17.3350	0.2500	133.8350	354.8391	50.3936	68.1175	417.4068	640.6959	640.6959
17	20.8020	0.3000	133.8350	354.8391	50.3936	68.1175	417.4068	640.6959	640.6959
18	24.2690	0.3500	133.8350	354.8391	50.3936	68.1175	417.4068	640.6959	640.6959
19	27.7360	0.4000	133.8350	354.8391	50.3936	68.1175	417.4068	640.6959	640.6959
20	31.2030	0.4500	133.8350	354.8391	50.3936	68.1175	417.4068	640.6959	640.6959
21	34.6700	0.5000	133.8350	354.8391	50.3936	68.1175	417.4068	640.6959	640.6959

I	YHS	YH	MM	MT
1	-34.6700	-0.5000	-4167.0103	-4266.6187
2	-31.2030	-0.4500	-4167.0103	-4266.6187
3	-27.7360	-0.4000	-4167.0103	-4266.6187
4	-24.2690	-0.3500	-4167.0103	-4266.6187
5	-20.8020	-0.3000	-4167.0103	-4266.6187
6	-17.3350	-0.2500	-4167.0103	-4266.6187
7	-13.8680	-0.2000	-4167.0103	-4266.6187
8	-10.4010	-0.1500	-4167.0103	-4266.6187
9	-6.9340	-0.1000	-4167.0103	-4266.6187
10	-3.4670	-0.0500	-4167.0103	-4266.6187
11	0.0000	0.0000	-4167.0103	-4266.6187
12	3.4670	0.0500	-4167.0103	-4266.6187
13	6.9340	0.1000	-4167.0103	-4266.6187
14	10.4010	0.1500	-4167.0103	-4266.6187
15	13.8680	0.2000	-4167.0103	-4266.6187
16	17.3350	0.2500	-4167.0103	-4266.6187
17	20.8020	0.3000	-4167.0103	-4266.6187
18	24.2690	0.3500	-4167.0103	-4266.6187
19	27.7360	0.4000	-4167.0103	-4266.6187
20	31.2030	0.4500	-4167.0103	-4266.6187
21	34.6700	0.5000	-4167.0103	-4266.6187

(p) Tabulated data without vortex-, jet-, or propeller-wake effects:

$$\epsilon_1 = 10.0^\circ, \epsilon_2 = 0^\circ.$$

Figure 42.- Continued.

DTRUSS(LB/FT)= 23.7890 LTRUSS(LB/FT)= 0.0000 MTRUSS(FT-LB/FT)= -133.6935
 QFS = DI = DVOR = LI = MM = 0.0

I	YFS	YH	DV	DDT	DT	LLT	LVOR	LT
1	-34.6700	-0.5000	179.6319	127.0189	150.8079	127.0189	120.0000	247.0189
2	-31.2030	-0.4500	179.6319	127.0189	150.8079	127.0189	128.3916	255.4105
3	-27.7360	-0.4000	179.6319	127.0189	150.8079	127.0189	136.7832	263.8022
4	-24.2690	-0.3500	179.6319	127.0189	150.8079	127.0189	145.1831	272.2020
5	-20.8020	-0.3000	179.6319	127.0189	150.8079	127.0189	153.6338	280.6527
6	-17.3350	-0.2500	179.6319	127.0189	150.8079	127.0189	162.0000	289.0190
7	-13.8680	-0.2000	179.6319	127.0189	150.8079	127.0189	171.2000	298.2189
8	-10.4010	-0.1500	179.6319	127.0189	150.8079	127.0189	181.6389	308.6578
9	-6.9340	-0.1000	179.6319	127.0189	150.8079	127.0189	193.7500	320.7690
10	-3.4670	-0.0500	179.6319	127.0189	150.8079	127.0189	205.5000	332.5190
11	0.0000	0.0000	179.6319	127.0189	150.8079	127.0189	0.0000	127.0189
12	3.4670	0.0500	179.6319	127.0189	150.8079	127.0189	-205.5000	-78.4811
13	6.9340	0.1000	179.6319	127.0189	150.8079	127.0189	-193.7500	-66.7311
14	10.4010	0.1500	179.6319	127.0189	150.8079	127.0189	-181.6389	-54.6200
15	13.8680	0.2000	179.6319	127.0189	150.8079	127.0189	-171.2000	-44.1811
16	17.3350	0.2500	179.6319	127.0189	150.8079	127.0189	-162.0000	-34.9811
17	20.8020	0.3000	179.6319	127.0189	150.8079	127.0189	-153.6338	-26.6149
18	24.2690	0.3500	179.6319	127.0189	150.8079	127.0189	-145.1831	-18.1642
19	27.7360	0.4000	179.6319	127.0189	150.8079	127.0189	-136.7832	-9.7643
20	31.2030	0.4500	179.6319	127.0189	150.8079	127.0189	-128.3916	-1.3727
21	34.6700	0.5000	179.6319	127.0189	150.8079	127.0189	-120.0000	7.0189

I	YHS	YH	MVOR	MT
1	-34.6700	-0.5000	7.5900	-126.1035
2	-31.2030	-0.4500	10.1886	-123.5049
3	-27.7360	-0.4000	13.0522	-120.6412
4	-24.2690	-0.3500	16.2223	-117.4712
5	-20.8020	-0.3000	20.0955	-113.5980
6	-17.3350	-0.2500	23.8200	-109.8735
7	-13.8680	-0.2000	27.3927	-106.3008
8	-10.4010	-0.1500	30.7237	-102.9698
9	-6.9340	-0.1000	32.7308	-100.9626
10	-3.4670	-0.0500	33.8060	-99.8875
11	0.0000	0.0000	24.2000	-109.4935
12	3.4670	0.0500	14.9080	-118.7855
13	6.9340	0.1000	6.8317	-126.8618
14	10.4010	0.1500	4.8880	-128.8054
15	13.8680	0.2000	8.3739	-125.3195
16	17.3350	0.2500	9.9000	-123.7934
17	20.8020	0.3000	10.3415	-123.3519
18	24.2690	0.3500	9.9542	-123.7392
19	27.7360	0.4000	9.3087	-124.3847
20	31.2030	0.4500	8.7148	-124.9787
21	34.6700	0.5000	8.2500	-125.4435

(q) Tabulated data with vortex-wake effect: $\epsilon_1 = 0^\circ$, $\epsilon_2 = 0^\circ$.

Figure 42.- Continued.

DTRUSS(LB/FT)= 21.5366		LTRUSS(LB/FT)= 0.0000		MTRUSS(FT-LB/FT)= -121.0351						
QFS = DVOR = 0.0										
I	YFS	YH	DV	DI	DDT	DT	LI	LLT	LWOR	LT
1	-34.6700	-0.5000	162.6240	131.7739	110.1093	131.6459	138.6799	306.2323	120.0000	426.2323
2	-31.2030	-0.4500	162.6240	131.7739	110.1093	131.6459	138.6799	306.2323	128.3916	434.6239
3	-27.7360	-0.4000	162.6240	131.7739	110.1093	131.6459	138.6799	306.2323	136.7832	443.0155
4	-24.2690	-0.3500	162.6240	131.7739	110.1093	131.6459	138.6799	306.2323	145.1831	451.4154
5	-20.8020	-0.3000	162.6240	131.7739	110.1093	131.6459	138.6799	306.2323	153.6338	459.8661
6	-17.3350	-0.2500	162.6240	131.7739	110.1093	131.6459	138.6799	306.2323	162.0000	468.2323
7	-13.8680	-0.2000	162.6240	131.7739	110.1093	131.6459	138.6799	306.2323	171.2000	477.4323
8	-10.4010	-0.1500	162.6240	131.7739	110.1093	131.6459	138.6799	306.2323	181.6389	487.8712
9	-6.9340	-0.1000	162.6240	131.7739	110.1093	131.6459	138.6799	306.2323	193.7500	499.9823
10	-3.4670	-0.0500	162.6240	131.7739	110.1093	131.6459	138.6799	306.2323	205.5000	511.7323
11	0.0000	0.0000	162.6240	131.7739	110.1093	131.6459	138.6799	306.2323	-205.5000	100.7323
12	3.4670	0.0500	162.6240	131.7739	110.1093	131.6459	138.6799	306.2323	-193.7500	112.4823
13	6.9340	0.1000	162.6240	131.7739	110.1093	131.6459	138.6799	306.2323	-181.6389	124.5934
14	10.4010	0.1500	162.6240	131.7739	110.1093	131.6459	138.6799	306.2323	-171.2000	135.0323
15	13.8680	0.2000	162.6240	131.7739	110.1093	131.6459	138.6799	306.2323	-162.0000	144.2323
16	17.3350	0.2500	162.6240	131.7739	110.1093	131.6459	138.6799	306.2323	-153.6338	152.5985
17	20.8020	0.3000	162.6240	131.7739	110.1093	131.6459	138.6799	306.2323	-145.1831	161.0492
18	24.2690	0.3500	162.6240	131.7739	110.1093	131.6459	138.6799	306.2323	-136.7832	169.4491
19	27.7360	0.4000	162.6240	131.7739	110.1093	131.6459	138.6799	306.2323	-128.3916	177.8407
20	31.2030	0.4500	162.6240	131.7739	110.1093	131.6459	138.6799	306.2323	-120.0000	186.2323
21	34.6700	0.5000	162.6240	131.7739	110.1093	131.6459	138.6799	306.2323		

I	YHS	YH	MVOR	MM	MT
1	-34.6700	-0.5000	7.5900	829.3452	715.9001
2	-31.2030	-0.4500	10.1886	829.3452	718.4987
3	-27.7360	-0.4000	13.0522	829.3452	721.3623
4	-24.2690	-0.3500	16.2223	829.3452	724.5323
5	-20.8020	-0.3000	20.0955	829.3452	728.4056
6	-17.3350	-0.2500	23.8200	829.3452	732.1301
7	-13.8680	-0.2000	27.3927	829.3452	735.7028
8	-10.4010	-0.1500	30.7237	829.3452	739.0338
9	-6.9340	-0.1000	32.7308	829.3452	741.0409
10	-3.4670	-0.0500	33.8060	829.3452	742.1161
11	0.0000	0.0000	24.2000	829.3452	732.5101
12	3.4670	0.0500	14.9080	829.3452	723.2181
13	6.9340	0.1000	6.8317	829.3452	715.1417
14	10.4010	0.1500	4.8880	829.3452	713.1981
15	13.8680	0.2000	8.3739	829.3452	716.6840
16	17.3350	0.2500	9.9000	829.3452	718.2101
17	20.8020	0.3000	10.3415	829.3452	718.6516
18	24.2690	0.3500	9.9542	829.3452	718.2643
19	27.7360	0.4000	9.3087	829.3452	717.6188
20	31.2030	0.4500	8.7148	829.3452	717.0248
21	34.6700	0.5000	8.2500	829.3452	716.5601

(r) Tabulated data with vortex-wake effect: $\epsilon_1 = 3.0^\circ$, $\epsilon_2 = 0^\circ$.

Figure 42.- Continued.

DTRUSS(LB/FT) = 20.2657 LTRUSS(LB/FT) = 0.0000 MTRUSS(FT-LB/FT) = -113.8929
QFS = DVOR = 0.0

I	YFS	YH	DV	DI	DDT	DT	LI	LLT	LVOR	LT
1	-34.6700	-0.5000	153.0277	205.9921	95.4635	115.7292	224.0140	412.2672	120.0000	532.2672
2	-31.2030	-0.4500	153.0277	205.9921	95.4635	115.7292	224.0140	412.2672	128.3916	540.6588
3	-27.7360	-0.4000	153.0277	205.9921	95.4635	115.7292	224.0140	412.2672	136.7832	549.0504
4	-24.2690	-0.3500	153.0277	205.9921	95.4635	115.7292	224.0140	412.2672	145.1831	557.4503
5	-20.8020	-0.3000	153.0277	205.9921	95.4635	115.7292	224.0140	412.2672	153.6338	565.9010
6	-17.3350	-0.2500	153.0277	205.9921	95.4635	115.7292	224.0140	412.2672	162.0000	574.2672
7	-13.8680	-0.2000	153.0277	205.9921	95.4635	115.7292	224.0140	412.2672	171.2000	583.4672
8	-10.4010	-0.1500	153.0277	205.9921	95.4635	115.7292	224.0140	412.2672	181.6389	593.9061
9	-6.9340	-0.1000	153.0277	205.9921	95.4635	115.7292	224.0140	412.2672	193.7500	606.0172
10	-3.4670	-0.0500	153.0277	205.9921	95.4635	115.7292	224.0140	412.2672	205.5000	617.7672
11	0.0000	0.0000	153.0277	205.9921	95.4635	115.7292	224.0140	412.2672	0.0000	412.2672
12	3.4670	0.0500	153.0277	205.9921	95.4635	115.7292	224.0140	412.2672	-205.5000	206.7672
13	6.9340	0.1000	153.0277	205.9921	95.4635	115.7292	224.0140	412.2672	-193.7500	218.5172
14	10.4010	0.1500	153.0277	205.9921	95.4635	115.7292	224.0140	412.2672	-181.6389	230.6283
15	13.8680	0.2000	153.0277	205.9921	95.4635	115.7292	224.0140	412.2672	-171.2000	241.0672
16	17.3350	0.2500	153.0277	205.9921	95.4635	115.7292	224.0140	412.2672	-162.0000	250.2672
17	20.8020	0.3000	153.0277	205.9921	95.4635	115.7292	224.0140	412.2672	-153.6338	258.6334
18	24.2690	0.3500	153.0277	205.9921	95.4635	115.7292	224.0140	412.2672	-145.1831	267.0841
19	27.7360	0.4000	153.0277	205.9921	95.4635	115.7292	224.0140	412.2672	-136.7832	275.4839
20	31.2030	0.4500	153.0277	205.9921	95.4635	115.7292	224.0140	412.2672	-128.3916	283.8755
21	34.6700	0.5000	153.0277	205.9921	95.4635	115.7292	224.0140	412.2672	-120.0000	292.2672

I	YHS	YH	MVOR	MM	MT
1	-34.6700	-0.5000	7.5900	1314.3682	1208.0652
2	-31.2030	-0.4500	10.1886	1314.3682	1210.6638
3	-27.7360	-0.4000	13.0522	1314.3682	1213.5275
4	-24.2690	-0.3500	16.2223	1314.3682	1216.6975
5	-20.8020	-0.3000	20.0955	1314.3682	1220.5707
6	-17.3350	-0.2500	23.8200	1314.3682	1224.2952
7	-13.8680	-0.2000	27.3927	1314.3682	1227.8679
8	-10.4010	-0.1500	30.7237	1314.3682	1231.1989
9	-6.9340	-0.1000	32.7308	1314.3682	1233.2061
10	-3.4670	-0.0500	33.8060	1314.3682	1234.2813
11	0.0000	0.0000	24.2000	1314.3682	1224.6752
12	3.4670	0.0500	14.9080	1314.3682	1215.3832
13	6.9340	0.1000	6.8317	1314.3682	1207.3069
14	10.4010	0.1500	4.8880	1314.3682	1205.3633
15	13.8680	0.2000	8.3739	1314.3682	1208.8491
16	17.3350	0.2500	9.9000	1314.3682	1210.3752
17	20.8020	0.3000	10.3415	1314.3682	1210.8168
18	24.2690	0.3500	9.9542	1314.3682	1210.4294
19	27.7360	0.4000	9.3087	1314.3682	1209.7839
20	31.2030	0.4500	8.7148	1314.3682	1208.1901
21	34.6700	0.5000	8.2500	1314.3682	1208.7252

(s) Tabulated data with vortex-wake effect: $\epsilon_1 = 5.0^\circ$, $\epsilon_2 = 0^\circ$.

Figure 42.- Continued.

	DTRUSS(LB/FT)= 17.7240		LTRUSS(LB/FT)= 0.0000		MTRUSS(FT-LB/FT)= -99.6085					
	QFS = DVOR = 0.0									
I	YFS	YH	DV	DI	DDT	DT	LI	LLT	LVOR	LT
1	-34.6700	-0.5000	133.8350	354.8391	50.3936	68.1175	417.4068	640.6959	120.0000	760.6959
2	-31.2030	-0.4500	133.8350	354.8391	50.3936	68.1175	417.4068	640.6959	128.3916	769.0875
3	-27.7360	-0.4000	133.8350	354.8391	50.3936	68.1175	417.4068	640.6959	136.7832	777.4791
4	-24.2690	-0.3500	133.8350	354.8391	50.3936	68.1175	417.4068	640.6959	145.1831	785.8790
5	-20.8020	-0.3000	133.8350	354.8391	50.3936	68.1175	417.4068	640.6959	153.6338	794.3298
6	-17.3350	-0.2500	133.8350	354.8391	50.3936	68.1175	417.4068	640.6959	162.0000	802.6959
7	-13.8680	-0.2000	133.8350	354.8391	50.3936	68.1175	417.4068	640.6959	171.2000	811.8959
8	-10.4010	-0.1500	133.8350	354.8391	50.3936	68.1175	417.4068	640.6959	181.6389	822.3348
9	-6.9340	-0.1000	133.8350	354.8391	50.3936	68.1175	417.4068	640.6959	193.7500	834.4459
10	-3.4670	-0.0500	133.8350	354.8391	50.3936	68.1175	417.4068	640.6959	205.5000	846.1959
11	0.0000	0.0000	133.8350	354.8391	50.3936	68.1175	417.4068	640.6959	0.0000	858.4459
12	3.4670	0.0500	133.8350	354.8391	50.3936	68.1175	417.4068	640.6959	-205.5000	870.6959
13	6.9340	0.1000	133.8350	354.8391	50.3936	68.1175	417.4068	640.6959	-193.7500	882.9459
14	10.4010	0.1500	133.8350	354.8391	50.3936	68.1175	417.4068	640.6959	-181.6389	895.1959
15	13.8680	0.2000	133.8350	354.8391	50.3936	68.1175	417.4068	640.6959	-171.2000	907.4459
16	17.3350	0.2500	133.8350	354.8391	50.3936	68.1175	417.4068	640.6959	-162.0000	919.6959
17	20.8020	0.3000	133.8350	354.8391	50.3936	68.1175	417.4068	640.6959	-153.6338	931.9459
18	24.2690	0.3500	133.8350	354.8391	50.3936	68.1175	417.4068	640.6959	-145.1831	944.1959
19	27.7360	0.4000	133.8350	354.8391	50.3936	68.1175	417.4068	640.6959	-136.7832	956.4459
20	31.2030	0.4500	133.8350	354.8391	50.3936	68.1175	417.4068	640.6959	-128.3916	968.6959
21	34.6700	0.5000	133.8350	354.8391	50.3936	68.1175	417.4068	640.6959	-120.0000	980.9459

	YHS	YH	MVOR	MM	MT
1	-34.6700	-0.5000	7.5900	-4167.0103	-4259.0288
2	-31.2030	-0.4500	10.1886	-4167.0103	-4256.4302
3	-27.7360	-0.4000	13.0522	-4167.0103	-4253.5664
4	-24.2690	-0.3500	16.2223	-4167.0103	-4250.3965
5	-20.8020	-0.3000	20.0955	-4167.0103	-4246.5229
6	-17.3350	-0.2500	23.8200	-4167.0103	-4242.7988
7	-13.8680	-0.2000	27.3927	-4167.0103	-4238.2261
8	-10.4010	-0.1500	30.7237	-4167.0103	-4235.8950
9	-6.9340	-0.1000	32.7308	-4167.0103	-4233.8877
10	0.0000	0.0000	33.8060	-4167.0103	-4232.8125
11	3.4670	0.0500	24.2000	-4167.0103	-4242.4185
12	6.9340	0.1000	14.9080	-4167.0103	-4251.7104
13	10.4010	0.1500	6.8317	-4167.0103	-4259.7871
14	13.8680	0.2000	4.8880	-4167.0103	-4261.7305
15	17.3350	0.2500	8.3739	-4167.0103	-4258.2446
16	20.8020	0.3000	9.9000	-4167.0103	-4256.7188
17	24.2690	0.3500	10.3415	-4167.0103	-4256.2773
18	27.7360	0.4000	9.9542	-4167.0103	-4256.6646
19	31.2030	0.4500	9.3087	-4167.0103	-4257.3101
20	34.6700	0.5000	8.7148	-4167.0103	-4257.9038
21			8.2500	-4167.0103	-4258.3687

(t) Tabulated data with vortex-wake effect: $\epsilon_1 = 10.0^\circ$, $\epsilon_2 = 0^\circ$.

Figure 42.- Continued.

I	YFS	YH-YJH	QJET	DV	DDT	DJTRUSS	DT	LLT	LT
1	-34.6700	-0.5000	41.1600	176.3331	124.6863	23.3521	148.0385	124.6863	124.6863
2	-30.0242	-0.4330	41.2900	176.8901	125.0802	23.4259	148.5060	125.0802	125.0802
3	-23.9916	-0.3460	41.9200	179.5890	126.9886	23.7833	150.7719	126.9886	126.9886
4	-18.0284	-0.2600	45.1800	193.5552	136.8642	25.6328	162.4970	136.8642	136.8642
5	-11.9958	-0.1730	54.2200	232.2833	164.2491	30.7617	195.0108	164.2491	164.2491
6	-6.0326	-0.0870	68.5200	293.5458	207.5682	38.8748	246.4430	207.5682	207.5682
7	0.0000	0.0000	76.5600	327.9899	231.9239	43.4363	275.3601	231.9239	231.9239
8	6.0326	0.0870	68.5200	293.5458	207.5682	38.8748	246.4430	207.5682	207.5682
9	11.9958	0.1730	54.2200	232.2833	164.2491	30.7617	195.0108	164.2491	164.2491
10	18.0284	0.2600	45.1800	193.5552	136.8642	25.6328	162.4970	136.8642	136.8642
11	23.9916	0.3460	41.9200	179.5890	126.9886	23.7833	150.7719	126.9886	126.9886
12	30.0242	0.4330	41.2900	176.8901	125.0802	23.4259	148.5060	125.0802	125.0802
13	34.6700	0.5000	41.1600	176.3331	124.6863	23.3521	148.0385	124.6863	124.6863

I	YFS	YH-YJH	QJET	MM	MJTRUSS	MT	DI = LI = LJTRUSS = 0.0
1	-34.6700	-0.5000	41.1600	0.0000	-131.2383	-131.2383	
2	-30.0242	-0.4330	41.2900	0.0000	-131.6528	-131.6528	
3	-23.9916	-0.3460	41.9200	0.0000	-133.6616	-133.6616	
4	-18.0284	-0.2600	45.1800	0.0000	-144.0560	-144.0560	
5	-11.9958	-0.1730	54.2200	0.0000	-172.8800	-172.8800	
6	-6.0326	-0.0870	68.5200	0.0000	-218.4754	-218.4754	
7	0.0000	0.0000	76.5600	0.0000	-244.1109	-244.1109	
8	6.0326	0.0870	68.5200	0.0000	-218.4754	-218.4754	
9	11.9958	0.1730	54.2200	0.0000	-172.8800	-172.8800	
10	18.0284	0.2600	45.1800	0.0000	-144.0560	-144.0560	
11	23.9916	0.3460	41.9200	0.0000	-133.6616	-133.6616	
12	30.0242	0.4330	41.2900	0.0000	-131.6528	-131.6528	
13	34.6700	0.5000	41.1600	0.0000	-131.2383	-131.2383	

$\epsilon_1 = 0^\circ, \epsilon_2 = 0^\circ$

I	YFS	YH-YJH	QJET	DV	DI	DDT	DJTRUSS	DT	LI	LLT	LT
1	-34.6700	-0.5000	41.1600	176.3331	142.8823	119.3914	23.3521	142.7435	150.3705	332.0474	332.0474
2	-30.0242	-0.4330	41.2900	176.8901	143.3336	119.7685	23.4259	143.1944	150.8454	333.0962	333.0962
3	-23.9916	-0.3460	41.9200	179.5890	145.5206	121.5959	23.7833	145.3792	153.1470	338.1785	338.1785
4	-18.0284	-0.2600	45.1800	193.5552	156.8373	131.0521	25.6328	156.6849	165.0568	364.4777	364.4777
5	-11.9958	-0.1730	54.2200	232.2833	188.2187	157.2741	30.7617	188.0358	198.0828	437.4055	437.4055
6	-6.0326	-0.0870	68.5200	293.5458	237.8595	198.7537	38.8748	237.6284	250.3252	552.7670	552.7670
7	0.0000	0.0000	76.5600	327.9899	285.7695	222.0750	43.4363	265.5113	279.6979	617.6276	617.6276
8	6.0326	0.0870	68.5200	293.5458	237.8595	198.7537	38.8748	237.6284	250.3252	552.7670	552.7670
9	11.9958	0.1730	54.2200	232.2833	188.2187	157.2741	30.7617	188.0358	198.0828	437.4055	437.4055
10	18.0284	0.2600	45.1800	193.5552	156.8373	131.0521	25.6328	156.6849	165.0568	364.4777	364.4777
11	23.9916	0.3460	41.9200	179.5890	145.5206	121.5959	23.7833	145.3792	153.1470	338.1785	338.1785
12	30.0242	0.4330	41.2900	176.8901	143.3336	119.7685	23.4259	143.1944	150.8454	333.0962	333.0962
13	34.6700	0.5000	41.1600	176.3331	142.8823	119.3914	23.3521	142.7435	150.3705	332.0474	332.0474

I	YFS	YH-YJH	QJET	MM	MJTRUSS	MT	LJTRUSS = 0.0
1	-34.6700	-0.5000	41.1600	899.2584	-131.2383	768.0201	
2	-30.0242	-0.4330	41.2900	902.0986	-131.6528	770.4458	
3	-23.9916	-0.3460	41.9200	915.8627	-133.6616	782.2012	
4	-18.0284	-0.2600	45.1800	987.0869	-144.0560	843.0308	
5	-11.9958	-0.1730	54.2200	1184.5917	-172.8800	1011.7117	
6	-6.0326	-0.0870	68.5200	1497.0161	-218.4754	1278.5406	
7	0.0000	0.0000	76.5600	1672.6730	-244.1109	1428.5620	
8	6.0326	0.0870	68.5200	1497.0161	-218.4754	1278.5406	
9	11.9958	0.1730	54.2200	1184.5917	-172.8800	1011.7117	
10	18.0284	0.2600	45.1800	987.0869	-144.0560	843.0308	
11	23.9916	0.3460	41.9200	915.8627	-133.6616	782.2012	
12	30.0242	0.4330	41.2900	902.0986	-131.6528	770.4458	
13	34.6700	0.5000	41.1600	899.2584	-131.2383	768.0201	

$\epsilon_1 = 3.0^\circ, \epsilon_2 = 0^\circ$

(u) Tabulated data with jet wake effect.
Figure 42.- Continued.

I	YFS	YH-YJH	QJET	DV	DI	DDT	DJTRUSS	DT	LI	LLT	LT
1	-34.6700	-0.5000	41.1600	176.3331	237.3638	110.0021	23.3521	133.3542	258.1304	475.0536	475.0536
2	-30.0242	-0.4330	41.2900	176.8901	238.1135	112.3496	23.4259	133.7754	258.9457	476.5541	476.5541
3	-23.9916	-0.3460	41.9200	179.5890	241.7466	112.0333	23.7833	135.8165	262.8966	483.8253	483.8253
4	-18.0284	-0.2600	45.1800	193.5552	260.5465	120.7458	25.6328	146.3786	283.3414	521.4510	521.4510
5	-11.9958	-0.1730	54.2200	232.2833	312.6789	144.9056	30.7617	175.6673	340.0348	625.7874	625.7874
6	-6.0326	-0.0870	68.5200	293.5458	395.1449	183.1231	38.8748	221.9978	429.7156	790.8327	790.8327
7	0.0000	0.0000	76.5600	327.9099	441.5104	204.6104	43.4363	248.0466	480.1376	883.6274	883.6274
8	6.0326	0.0870	68.5200	293.5458	395.1449	183.1231	38.8748	221.9978	429.7156	790.8327	790.8327
9	11.9958	0.1730	54.2200	232.2833	312.6789	144.9056	30.7617	175.6673	340.0348	625.7874	625.7874
10	18.0284	0.2600	45.1800	193.5552	260.5465	120.7458	25.6328	146.3786	283.3414	521.4510	521.4510
11	23.9916	0.3460	41.9200	179.5890	241.7466	112.0333	23.7833	135.8165	262.8966	483.8253	483.8253
12	30.0242	0.4330	41.2900	176.8901	238.1135	110.3496	23.4259	133.7754	258.9457	476.5541	476.5541
13	34.6700	0.5000	41.1600	176.3331	237.3638	110.0021	23.3521	133.3542	258.1304	475.0536	475.0536

I	YFS	YH-YJH	QJET	MM	MJTRUSS	MT	LJTRUSS
1	-34.6700	-0.5000	41.1600	1514.5406	-131.2383	1383.3024	0.0
2	-30.0242	-0.4330	41.2900	1519.3242	-131.6528	1387.6714	0.0
3	-23.9916	-0.3460	41.9200	1542.5059	-133.6616	1408.8444	0.0
4	-18.0284	-0.2600	45.1800	1662.4623	-144.0560	1518.4063	0.0
5	-11.9958	-0.1730	54.2200	1995.1021	-172.8800	1822.2220	0.0
6	-6.0326	-0.0870	68.5200	2521.2905	-218.4754	2302.8152	0.0
7	0.0000	0.0000	76.5600	2817.1338	-244.1109	2573.0229	0.0
8	6.0326	0.0870	68.5200	2521.2905	-218.4754	2302.8152	0.0
9	11.9958	0.1730	54.2200	1995.1021	-172.8800	1822.2220	0.0
10	18.0284	0.2600	45.1800	1662.4623	-144.0560	1518.4063	0.0
11	23.9916	0.3460	41.9200	1542.5059	-133.6616	1408.8444	0.0
12	30.0242	0.4330	41.2900	1519.3242	-131.6528	1387.6714	0.0
13	34.6700	0.5000	41.1600	1514.5406	-131.2383	1383.3024	0.0

$\epsilon_1 = 5^\circ, \epsilon_2 = 0^\circ.$

I	YFS	YH-YJH	QJET	DV	DI	DDT	DJTRUSS	DT	LI	LLT	LT
1	-34.6700	-0.5000	41.1600	176.3331	467.5153	66.3957	23.3521	89.7478	549.9508	844.1436	844.1436
2	-30.0242	-0.4330	41.2900	176.8901	468.9919	66.6053	23.4259	90.0312	551.6878	846.8097	846.8097
3	-23.9916	-0.3460	41.9200	179.5890	476.1477	67.6216	23.7833	91.4049	560.1053	859.7302	859.7302
4	-18.0284	-0.2600	45.1800	193.5552	513.1764	72.8803	25.6328	98.5132	603.6632	926.5891	926.5891
5	-11.9958	-0.1730	54.2200	232.2833	615.8571	87.4628	30.7617	118.2244	724.4493	1111.9889	1111.9889
6	-6.0326	-0.0870	68.5200	293.5458	778.2834	110.5303	38.8748	149.4051	915.5157	1405.2651	1405.2651
7	0.0000	0.0000	76.5600	327.9099	869.6057	123.4998	43.4363	166.9360	1022.9406	1570.1561	1570.1561
8	6.0326	0.0870	68.5200	293.5458	778.2834	110.5303	38.8748	149.4051	915.5157	1405.2651	1405.2651
9	11.9958	0.1730	54.2200	232.2833	615.8571	87.4628	30.7617	118.2244	724.4493	1111.9889	1111.9889
10	18.0284	0.2600	45.1800	193.5552	513.1764	72.8803	25.6328	98.5132	603.6632	926.5891	926.5891
11	23.9916	0.3460	41.9200	179.5890	476.1477	67.6216	23.7833	91.4049	560.1053	859.7302	859.7302
12	30.0242	0.4330	41.2900	176.8901	468.9919	66.6053	23.4259	90.0312	551.6878	846.8097	846.8097
13	34.6700	0.5000	41.1600	176.3331	467.5153	66.3957	23.3521	89.7478	549.9508	844.1436	844.1436

$\epsilon_1 = 10.0^\circ, \epsilon_2 = 0^\circ.$

I	YFS	YH-YJH	QJET	MM	MJTRUSS	MT	LJTRUSS
1	-34.6700	-0.5000	41.1600	-5490.2095	-131.2383	-5621.4478	0.0
2	-30.0242	-0.4330	41.2900	-5507.5498	-131.6528	-5639.2026	0.0
3	-23.9916	-0.3460	41.9200	-5591.5830	-133.6616	-5725.2446	0.0
4	-18.0284	-0.2600	45.1800	-6026.4253	-144.0560	-6170.4814	0.0
5	-11.9958	-0.1730	54.2200	-7232.2437	-172.8800	-7405.1235	0.0
6	-6.0326	-0.0870	68.5200	-9139.6777	-218.4754	-9358.1533	0.0
7	0.0000	0.0000	76.5600	-10212.1094	-244.1109	-10456.2207	0.0
8	6.0326	0.0870	68.5200	-9139.6777	-218.4754	-9358.1533	0.0
9	11.9958	0.1730	54.2200	-7232.2437	-172.8800	-7405.1235	0.0
10	18.0284	0.2600	45.1800	-6026.4253	-144.0560	-6170.4814	0.0
11	23.9916	0.3460	41.9200	-5591.5830	-133.6616	-5725.2446	0.0
12	30.0242	0.4330	41.2900	-5507.5498	-131.6528	-5639.2026	0.0
13	34.6700	0.5000	41.1600	-5490.2095	-131.2383	-5621.4478	0.0

$\epsilon_1 = 10.0^\circ, \epsilon_2 = 0^\circ.$

(v) Tabulated data with jet wake effect.

Figure 42.- Continued.

I	YFS	YH-YJH	QHET	DV	DDT	DJTRUSS	DT	LLT	LT
1	-34.6700	0.5000	42.4200	181.7311	128.5033	24.0670	152.5702	128.5033	128.5033
2	-30.0242	-0.4330	42.4200	181.7311	128.5033	24.0670	152.5702	128.5033	128.5033
3	-23.9916	-0.3460	42.4200	181.7311	128.5033	24.0670	152.5702	128.5033	128.5033
4	-18.0284	-0.2600	43.3000	185.5011	131.1691	24.5662	155.7353	131.1691	131.1691
5	-11.9958	-0.1730	49.4500	211.8482	149.7993	28.0554	177.8547	149.7993	149.7993
6	-6.0326	-0.0870	67.9000	290.8897	205.6901	38.5230	244.2131	205.6901	205.6901
7	0.0000	0.0000	85.5800	366.6324	259.2482	48.5538	307.8020	259.2482	259.2482
8	6.0326	0.0870	67.9000	290.8897	205.6901	38.5230	244.2131	205.6901	205.6901
9	11.9958	0.1730	49.4500	211.8482	149.7993	28.0554	177.8547	149.7993	149.7993
10	18.0284	0.2600	43.3000	185.5011	131.1691	24.5662	155.7353	131.1691	131.1691
11	23.9916	0.3460	42.4200	181.7311	128.5033	24.0670	152.5702	128.5033	128.5033
12	30.0242	0.4330	42.4200	181.7311	128.5033	24.0670	152.5702	128.5033	128.5033
13	34.6700	0.5000	42.4200	181.7311	128.5033	24.0670	152.5702	128.5033	128.5033

$$DI = LI = LJTRUSS = 0.0$$

I	YFS	YH-YJH	QHET	MM	MJTRUSS	DDT	DJTRUSS	DT	LLT	LT
1	-34.6700	-0.5000	42.4200	0.0000	-135.2558	-135.2558	24.0670	147.1132	342.2121	342.2121
2	-30.0242	-0.4330	42.4200	0.0000	-135.2558	-135.2558	24.0670	147.1132	342.2121	342.2121
3	-23.9916	-0.3460	42.4200	0.0000	-135.2558	-135.2558	24.0670	147.1132	342.2121	342.2121
4	-18.0284	-0.2600	43.3000	0.0000	-138.0617	-138.0617	24.5662	150.1651	349.3113	349.3113
5	-11.9958	-0.1730	49.4500	0.0000	-157.6709	-157.6709	28.0554	171.4934	398.9248	398.9248
6	-6.0326	-0.0870	67.9000	0.0000	-216.4986	-216.4986	38.5230	235.4783	547.7653	547.7653
7	0.0000	0.0000	85.5800	0.0000	-272.8711	-272.8711	48.5538	312.6508	690.3940	690.3940
8	6.0326	0.0870	67.9000	0.0000	-216.4986	-216.4986	38.5230	235.4783	547.7653	547.7653
9	11.9958	0.1730	49.4500	0.0000	-157.6709	-157.6709	28.0554	171.4934	398.9248	398.9248
10	18.0284	0.2600	43.3000	0.0000	-138.0617	-138.0617	24.5662	150.1651	349.3113	349.3113
11	23.9916	0.3460	42.4200	0.0000	-135.2558	-135.2558	24.0670	147.1132	342.2121	342.2121
12	30.0242	0.4330	42.4200	0.0000	-135.2558	-135.2558	24.0670	147.1132	342.2121	342.2121
13	34.6700	0.5000	42.4200	0.0000	-135.2558	-135.2558	24.0670	147.1132	342.2121	342.2121

$$\epsilon_1 = 0^\circ, \epsilon_2 = 0^\circ$$

I	YFS	YH-YJH	QHET	DV	DI	DDT	DJTRUSS	DT	LI	LLT	LT
1	-34.6700	-0.5000	42.4200	181.7311	147.2563	123.0463	24.0670	147.1132	154.9737	342.2121	342.2121
2	-30.0242	-0.4330	42.4200	181.7311	147.2563	123.0463	24.0670	147.1132	154.9737	342.2121	342.2121
3	-23.9916	-0.3460	42.4200	181.7311	147.2563	123.0463	24.0670	147.1132	154.9737	342.2121	342.2121
4	-18.0284	-0.2600	43.3000	185.5011	150.3111	125.5989	24.5662	150.1651	158.1886	349.3113	349.3113
5	-11.9958	-0.1730	49.4500	211.8482	171.6602	143.4380	28.0554	171.4934	180.6565	398.9248	398.9248
6	-6.0326	-0.0870	67.9000	290.8897	235.7073	196.9553	38.5230	235.4783	248.0602	547.7653	547.7653
7	0.0000	0.0000	85.5800	366.6324	297.0814	248.2390	48.5538	312.6508	312.6508	690.3940	690.3940
8	6.0326	0.0870	67.9000	290.8897	235.7073	196.9553	38.5230	235.4783	248.0602	547.7653	547.7653
9	11.9958	0.1730	49.4500	211.8482	171.6602	143.4380	28.0554	171.4934	180.6565	398.9248	398.9248
10	18.0284	0.2600	43.3000	185.5011	150.3111	125.5989	24.5662	150.1651	158.1886	349.3113	349.3113
11	23.9916	0.3460	42.4200	181.7311	147.2563	123.0463	24.0670	147.1132	154.9737	342.2121	342.2121
12	30.0242	0.4330	42.4200	181.7311	147.2563	123.0463	24.0670	147.1132	154.9737	342.2121	342.2121
13	34.6700	0.5000	42.4200	181.7311	147.2563	123.0463	24.0670	147.1132	154.9737	342.2121	342.2121

$$LJTRUSS = 0.0$$

I	YFS	YH-YJH	QHET	MM	MJTRUSS	DDT	DJTRUSS	DT	LI	LLT	LT
1	-34.6700	-0.5000	42.4200	926.7867	-135.2558	791.5309	24.0670	147.1132	154.9737	342.2121	342.2121
2	-30.0242	-0.4330	42.4200	926.7867	-135.2558	791.5309	24.0670	147.1132	154.9737	342.2121	342.2121
3	-23.9916	-0.3460	42.4200	926.7867	-135.2558	791.5309	24.0670	147.1132	154.9737	342.2121	342.2121
4	-18.0284	-0.2600	43.3000	946.0128	-138.0617	807.9512	24.5662	150.1651	158.1886	349.3113	349.3113
5	-11.9958	-0.1730	49.4500	1080.3773	-157.6709	922.7064	28.0554	171.4934	180.6565	398.9248	398.9248
6	-6.0326	-0.0870	67.9000	1483.4706	-216.4986	1266.9720	38.5230	235.4783	248.0602	547.7653	547.7653
7	0.0000	0.0000	85.5800	1869.7410	-272.8711	1596.8699	48.5538	312.6508	312.6508	690.3940	690.3940
8	6.0326	0.0870	67.9000	1483.4706	-216.4986	1266.9720	38.5230	235.4783	248.0602	547.7653	547.7653
9	11.9958	0.1730	49.4500	1080.3773	-157.6709	922.7064	28.0554	171.4934	180.6565	398.9248	398.9248
10	18.0284	0.2600	43.3000	946.0128	-138.0617	807.9512	24.5662	150.1651	158.1886	349.3113	349.3113
11	23.9916	0.3460	42.4200	926.7867	-135.2558	791.5309	24.0670	147.1132	154.9737	342.2121	342.2121
12	30.0242	0.4330	42.4200	926.7867	-135.2558	791.5309	24.0670	147.1132	154.9737	342.2121	342.2121
13	34.6700	0.5000	42.4200	926.7867	-135.2558	791.5309	24.0670	147.1132	154.9737	342.2121	342.2121

$$\epsilon_1 = -3.0^\circ, \epsilon_2 = 0^\circ$$

(w) Tabulated data with propeller wake

Figure 42.- Continued.

I	YFS	YH-YJH	QJET	DV	DI	DDT	DJTRUSS	DT	LI	LLT	LT
1	-34.6700	-0.5000	42.4200	181.7311	244.6300	113.3696	24.0670	137.4365	266.0323	489.5961	489.5961
2	-30.0242	-0.4330	42.4200	181.7311	244.6300	113.3696	24.0670	137.4365	266.0323	489.5961	489.5961
3	-23.9916	-0.3460	42.4200	181.7311	244.6300	113.3696	24.0670	137.4365	266.0323	489.5961	489.5961
4	-18.0284	-0.2600	43.3000	185.5011	249.7048	115.7214	24.5662	140.2876	271.5511	499.7527	499.7527
5	-11.9958	-0.1730	49.4500	211.8482	285.1710	132.1575	28.0554	160.2130	310.1202	570.7338	570.7338
6	-6.0326	-0.0870	67.9000	290.8097	391.5695	181.4661	38.5230	219.9891	425.8274	783.6769	783.6769
7	0.0000	0.0000	85.5800	366.6324	493.5275	228.7168	48.5538	277.2706	536.7055	987.7330	987.7330
8	6.0326	0.0870	67.9000	290.8097	391.5695	181.4661	38.5230	219.9891	425.8274	783.6769	783.6769
9	11.9958	0.1730	49.4500	211.8482	285.1710	132.1575	28.0554	160.2130	310.1202	570.7338	570.7338
10	18.0284	0.2600	43.3000	185.5011	249.7048	115.7214	24.5662	140.2876	271.5511	499.7527	499.7527
11	23.9916	0.3460	42.4200	181.7311	244.6300	113.3696	24.0670	137.4365	266.0323	489.5961	489.5961
12	30.0242	0.4330	42.4200	181.7311	244.6300	113.3696	24.0670	137.4365	266.0323	489.5961	489.5961
13	34.6700	0.5000	42.4200	181.7311	244.6300	113.3696	24.0670	137.4365	266.0323	489.5961	489.5961

LJTRUSS = 0.0

MT

I	YFS	YH-YJH	QJET	MM	MJTRUSS	DI	DDT	DJTRUSS	DT	LI	LLT	LT
1	-34.6700	-0.5000	42.4200	1560.9041	-135.2558	481.8270	68.4282	24.0670	92.4951	566.7860	869.9846	869.9846
2	-30.0242	-0.4330	42.4200	1560.9041	-135.2558	481.8270	68.4282	24.0670	92.4951	566.7860	869.9846	869.9846
3	-23.9916	-0.3460	42.4200	1560.9041	-135.2558	481.8270	68.4282	24.0670	92.4951	566.7860	869.9846	869.9846
4	-18.0284	-0.2600	43.3000	1593.2850	-138.0617	491.8224	69.8477	24.5662	94.4139	578.5439	888.0324	888.0324
5	-11.9958	-0.1730	49.4500	1819.5830	-157.6709	561.6771	79.7683	28.0554	107.8237	660.7159	1014.1617	1014.1617
6	-6.0326	-0.0870	67.9000	2498.4771	-216.4986	771.2412	109.5302	38.5230	148.0532	907.2318	1392.5497	1392.5497
7	0.0000	0.0000	85.5800	3149.0378	-272.8711	972.0593	138.0500	48.5538	186.6037	1143.4595	1755.1459	1755.1459
8	6.0326	0.0870	67.9000	2498.4771	-216.4986	771.2412	109.5302	38.5230	148.0532	907.2318	1392.5497	1392.5497
9	11.9958	0.1730	49.4500	1819.5830	-157.6709	561.6771	79.7683	28.0554	107.8237	660.7159	1014.1617	1014.1617
10	18.0284	0.2600	43.3000	1593.2850	-138.0617	491.8224	69.8477	24.5662	94.4139	578.5439	888.0324	888.0324
11	23.9916	0.3460	42.4200	1560.9041	-135.2558	481.8270	68.4282	24.0670	92.4951	566.7860	869.9846	869.9846
12	30.0242	0.4330	42.4200	1560.9041	-135.2558	481.8270	68.4282	24.0670	92.4951	566.7860	869.9846	869.9846
13	34.6700	0.5000	42.4200	1560.9041	-135.2558	481.8270	68.4282	24.0670	92.4951	566.7860	869.9846	869.9846

$\epsilon_1 = 5.0^\circ, \epsilon_2 = 0^\circ$

I	YFS	YH-YJH	QJET	DV	DI	DDT	DJTRUSS	DT	LI	LLT	LT
1	-34.6700	-0.5000	42.4200	181.7311	481.8270	68.4282	24.0670	92.4951	566.7860	869.9846	869.9846
2	-30.0242	-0.4330	42.4200	181.7311	481.8270	68.4282	24.0670	92.4951	566.7860	869.9846	869.9846
3	-23.9916	-0.3460	42.4200	181.7311	481.8270	68.4282	24.0670	92.4951	566.7860	869.9846	869.9846
4	-18.0284	-0.2600	43.3000	185.5011	491.8224	69.8477	24.5662	94.4139	578.5439	888.0324	888.0324
5	-11.9958	-0.1730	49.4500	211.8482	561.6771	79.7683	28.0554	107.8237	660.7159	1014.1617	1014.1617
6	-6.0326	-0.0870	67.9000	290.8897	771.2412	109.5302	38.5230	148.0532	907.2318	1392.5497	1392.5497
7	0.0000	0.0000	85.5800	366.6324	972.0593	138.0500	48.5538	186.6037	1143.4595	1755.1459	1755.1459
8	6.0326	0.0870	67.9000	290.8897	771.2412	109.5302	38.5230	148.0532	907.2318	1392.5497	1392.5497
9	11.9958	0.1730	49.4500	211.8482	561.6771	79.7683	28.0554	107.8237	660.7159	1014.1617	1014.1617
10	18.0284	0.2600	43.3000	185.5011	491.8224	69.8477	24.5662	94.4139	578.5439	888.0324	888.0324
11	23.9916	0.3460	42.4200	181.7311	481.8270	68.4282	24.0670	92.4951	566.7860	869.9846	869.9846
12	30.0242	0.4330	42.4200	181.7311	481.8270	68.4282	24.0670	92.4951	566.7860	869.9846	869.9846
13	34.6700	0.5000	42.4200	181.7311	481.8270	68.4282	24.0670	92.4951	566.7860	869.9846	869.9846

LJTRUSS = 0.0

MT

I	YFS	YH-YJH	QJET	MM	MJTRUSS	DI	DDT	DJTRUSS	DT	LI	LLT	LT
1	-34.6700	-0.5000	42.4200	-5658.2769	-135.2558	-5793.5327	-5793.5327	-5793.5327	-5793.5327	-5793.5327	-5793.5327	-5793.5327
2	-30.0242	-0.4330	42.4200	-5658.2769	-135.2558	-5793.5327	-5793.5327	-5793.5327	-5793.5327	-5793.5327	-5793.5327	-5793.5327
3	-23.9916	-0.3460	42.4200	-5658.2769	-135.2558	-5793.5327	-5793.5327	-5793.5327	-5793.5327	-5793.5327	-5793.5327	-5793.5327
4	-18.0284	-0.2600	43.3000	-5775.6572	-138.0617	-5913.7188	-5913.7188	-5913.7188	-5913.7188	-5913.7188	-5913.7188	-5913.7188
5	-11.9958	-0.1730	49.4500	-6595.9878	-157.6709	-6753.6587	-6753.6587	-6753.6587	-6753.6587	-6753.6587	-6753.6587	-6753.6587
6	-6.0326	-0.0870	67.9000	-9056.9785	-216.4986	-9273.4775	-9273.4775	-9273.4775	-9273.4775	-9273.4775	-9273.4775	-9273.4775
7	0.0000	0.0000	85.5800	-11415.2607	-272.8711	-11688.1318	-11688.1318	-11688.1318	-11688.1318	-11688.1318	-11688.1318	-11688.1318
8	6.0326	0.0870	67.9000	-9056.9785	-216.4986	-9273.4775	-9273.4775	-9273.4775	-9273.4775	-9273.4775	-9273.4775	-9273.4775
9	11.9958	0.1730	49.4500	-6595.9878	-157.6709	-6753.6587	-6753.6587	-6753.6587	-6753.6587	-6753.6587	-6753.6587	-6753.6587
10	18.0284	0.2600	43.3000	-5775.6572	-138.0617	-5913.7188	-5913.7188	-5913.7188	-5913.7188	-5913.7188	-5913.7188	-5913.7188
11	23.9916	0.3460	42.4200	-5658.2769	-135.2558	-5793.5327	-5793.5327	-5793.5327	-5793.5327	-5793.5327	-5793.5327	-5793.5327
12	30.0242	0.4330	42.4200	-5658.2769	-135.2558	-5793.5327	-5793.5327	-5793.5327	-5793.5327	-5793.5327	-5793.5327	-5793.5327
13	34.6700	0.5000	42.4200	-5658.2769	-135.2558	-5793.5327	-5793.5327	-5793.5327	-5793.5327	-5793.5327	-5793.5327	-5793.5327

$\epsilon_1 = 10.0^\circ, \epsilon_2 = 0^\circ$

(x) Tabulated data with propeller wake effect.

Figure 42.- Concluded.

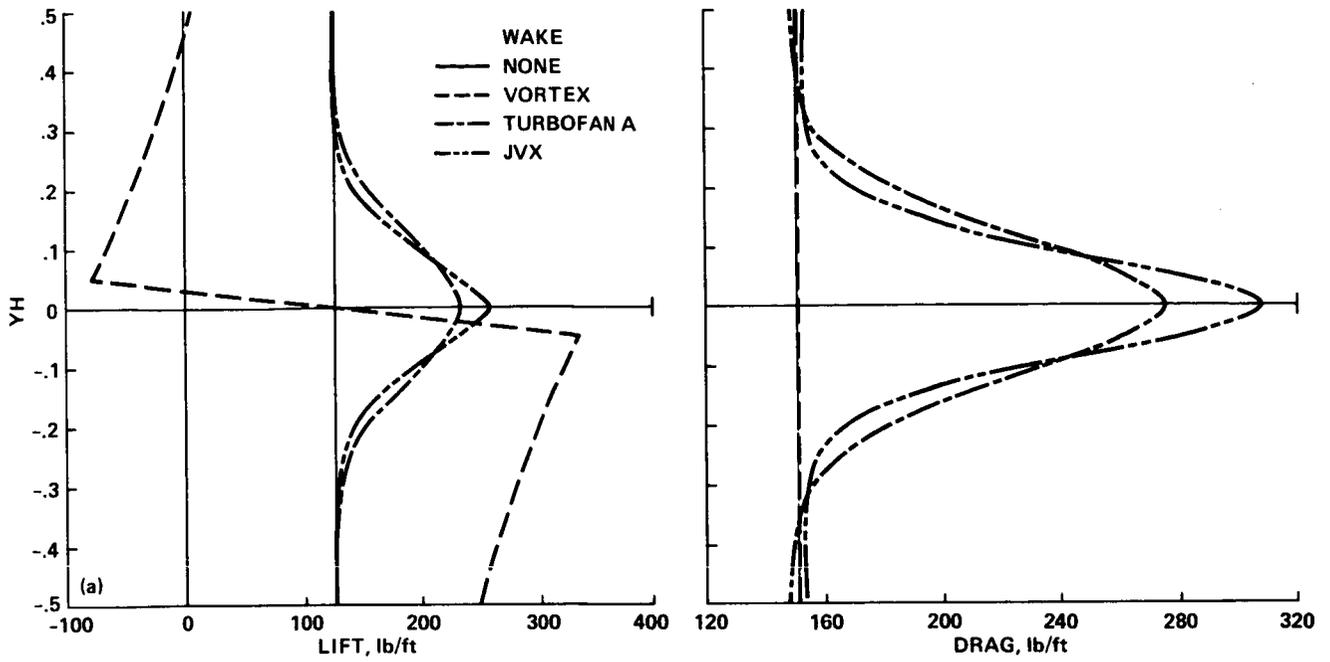

(a) Lift and drag.

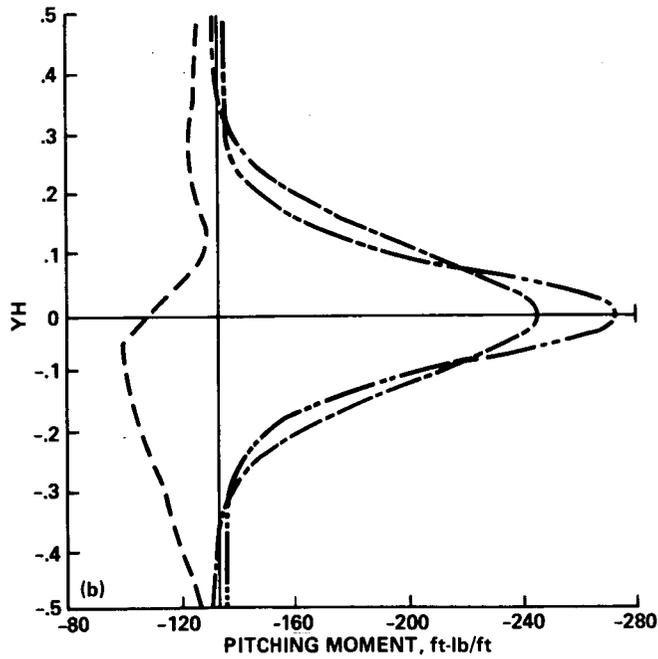

(b) Pitching moment.

Figure 43.- Effect of vortex, jet, and propeller wakes on spanwise vane loads
vane set 4: $\epsilon_1 = 0^\circ$, $\epsilon_2 = 0^\circ$, wake center at vane midspan.

Mode	Wall pressure difference ($P_{atm} - P_{static}$), lb/ft ²	Drag, lb/ft	Truss loads per vane span	
			Pitching moment, ft·lb/ft	Moment arm from vane surf, ft
40 × 80	62	26	146	5.62
Vane 4C additional load and pitching moment per space truss				
Mode	Drag, lb	Pitching moment, ft/lb		
80 × 120	167	-440		
40 × 80	182	480		

Figure 44.- Vane set 4 local loads and vane 4C space truss loads for 40 × 80 mode.

AERODYNAMIC DESIGN TIME AVERAGED LOADS
VANE SETS 5, NO JET OR VORTEX EFFECT

40 by 80 mode

80 by 120 mode

Global load (total vane span = 2714.0 ft)

Onset angle	deg	3.0	55.0	45.0
Outflow angle	deg	-2.7	-2.5	-1.5
Lift	lb	61000.	698900.	550900.
Drag	lb	75700.	130500.	140100.
Pitching moment about 1/4 vane chord	ft-lb	-414200.	188100.	-169400.

Note:

1. Loads acting at 1/4 vane chord.
2. Lift acting along vane set. Positive direction toward outside wall.
3. Drag perpendicular to vane set.

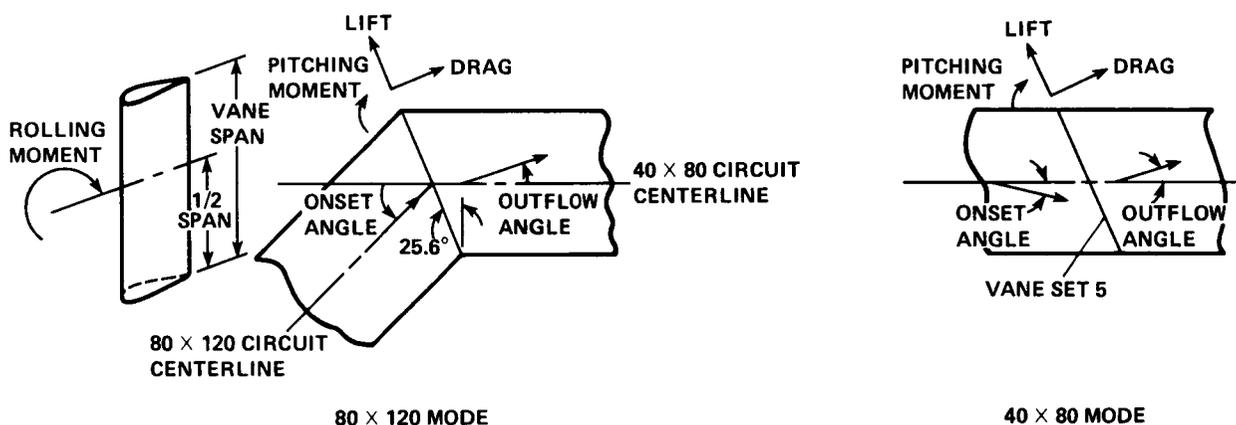

(a) Maximum global design loads without vortex-, jet-, or propeller-wake effects.

Figure 45.- Global design and operating loads for vane set 5.

80 BY 120 MODE

40 BY 80 MODE

GLOBAL LOAD (TOTAL VANE SPAN = 2714.0 FT)

	40 BY 80 MODE	80 BY 120 MODE
ONSET ANGLE	0.0	45.0
OUTFLOW ANGLE	-1.0	0.5
LIFT	13000.	523200.
DRAG	58000.	126500.
PITCHING MOMENT ABOUT 1/4 VANE CHORD	-434000.	-169400.

NOTE:

1. LOADS ACTING AT 1/4 VANE CHORD...
2. LIFT ACTING ALONG VANE SET. POSITIVE DIRECTION TOWARD OUTSIDE WALL.
3. DRAG PERPENDICULAR TO VANE SET.

(b) Global operating loads with no vortex or jet wake effect.

Figure 45.- Continued.

80 BY 120 MODE

GLOBAL LOAD (TOTAL VANE SPAN = 2714.0 FT)

ONSET ANGLE	DEG	55.0	45.0
OUTFLOW ANGLE	DEG	-2.5	-1.5
LIFT	LB	698900.	550900.
DRAG	LB	147700.	157300.
PITCHING MOMENT ABOUT 1/4 VANE CHORD	FT-LB	188100.	-169400.
ROLLING MOMENT ABOUT VANE MIDSPAN FOR ONE VANE SPAN (75.4 FT)	FT-LB	±102000.	±102000.

NOTE:

1. LOADS ACTING AT 1/4 VANE CHORD.
2. LIFT ACTING ALONG VANE SET. POSITIVE DIRECTION TOWARD OUTSIDE WALL.
3. DRAG PERPENDICULAR TO VANE SET.
4. 80 BY 120 MODE CONTAINS ADDITIONAL DRAG LOADS DUE TO VORTEX EFFECT.
5. ROLLING MOMENT ABOUT VANE MIDSPAN IS FOR ONE VANE SPAN (75.4 FT) ONLY.

(c) 80 x 120 mode maximum global design load with vortex-wake effect.

Figure 45.- Continued.

80 BY 120 MODE

GLOBAL LOAD (TOTAL VANE SPAN = 2714.0 FT)

ONSET ANGLE	DEG	55.0	45.0
OUTFLOW ANGLE	DEG	-2.5	-1.5
LIFT	LB	768900.	606000.
DRAG	LB	143600.	154100.
PITCHING MOMENT	FT-LB	192700.	-173600.

NOTE:

1. LOADS ACTING AT 1/4 VANE CHORD.
2. LIFT ACTING ALONG VANE SET. POSITIVE DIRECTION TOWARD OUTSIDE WALL.
3. DRAG PERPENDICULAR TO VANE SET.
4. 80 BY 120 MODE CONTAINS ADDITIONAL LOADS DUE TO JET EXHAUST.

(d) 80 x 120 mode maximum global design load with jet-wake effect.

80 BY 120 MODE

GLOBAL LOAD (TOTAL VANE SPAN = 2714.0 FT)

ONSET ANGLE	DEG	55.0	45.0
OUTFLOW ANGLE	DEG	-2.5	-1.5
LIFT	LB	774300.	610300.
DRAG	LB	144600.	155200.
PITCHING MOMENT	FT-LB	192700.	-173600.

NOTE:

1. LOADS ACTING AT 1/4 VANE CHORD.
2. LIFT ACTING ALONG VANE SET. POSITIVE DIRECTION TOWARD OUTSIDE WALL.
3. DRAG PERPENDICULAR TO VANE SET.
4. 80 BY 120 MODE CONTAINS ADDITIONAL LOADS DUE TO PROPELLER WAKE.

(e) 80 x 120 maximum global design load with propeller-wake effect.

Figure 45.- Continued.

VANE 5 DESIGN GLOBAL AND LOCAL LOADS
80 BY 120 MODE, NO JET OR VORTEX EFFECT

CONSTANT INPUTS	KNOTS	100.00	SPLITTER PLATE CD	SQ FT	0.025
TUNNEL SPEED	FAHREN.	60.0	TOTAL SPLITTER PLATE	2005.0	
TEMP. AROUND TUNL CIRCUIT	PSF	33.18	AREA (PLANFORM)		
TEST SECTION Q	SLUG/FT3	0.002313	NO. OF SPLITTER PLATES	2.0	
MASS DENSITY AT VANE	SQ FT	9689.0			
DP/QL ROUGHNESS	FT	75.4			
VANE SET FRONTAL AREA	FT	36.0			
INDIVID. VANE SPAN	FT	3.4			
NO. OF VANES	FT	6.7			
PITCH OF VANE SET	FT	2714.0			
VANE CHORD					
TOTAL VANE SPAN					
CALCULATION					
ONSET ANGLE	DEG	55.0	45.0	45.0	
OUTFLOW ANGLE	DEG	1.5	2.5	-1.5	
BETA 1	DEG	29.4	19.4	19.4	
BETA 2	DEG	-24.0	-23.1	-27.1	
Q AT 0 DEG ONSET	PSF	36.9	36.9	36.9	
VZ	FT/SEC	168.5	168.5	168.5	
Q AT ONSET ANGLE	PSF	43.3	36.9	36.9	
DP/QL VISCIOUS DRAG COEFF		0.273	0.205	0.205	
CM ABOUT 1/4 CHORD		0.036	0.038	0.038	
K1 (V/VAVG)2*A		1.000	1.000	1.000	
QMAX/QAVG		1.000	1.000	1.000	
F1		1.001	1.002	1.002	
F2		0.974	0.884	1.027	
F3		1.000	1.000	1.000	
MOMENTUM LIFT	LB	643618.6	496491.9	550863.6	
OTHER LIFT	LB	0.0	0.0	0.0	
TOTAL LIFT	LB	643618.6	496491.9	550863.6	
INVISCID DRAG	LB	-36667.8	19379.0	45047.5	
VISCOUS DRAG	LB	114470.1	73333.8	73333.8	
INVISCID+VISCOUS DRAG	LB	77802.3	92712.8	118381.4	
ROUGHNESS DRAG	LB	16772.2	14309.0	14309.0	
SPLITTER PLATE DRAG	LB	8676.9	7402.6	7402.6	
OTHER DRAG	LB	0.0	0.0	0.0	
TOTAL DRAG	LB	103251.4	114424.5	140093.0	
PITCHING MOMENT C/4	FTLB	188111.1	-169401.3	-169401.3	
OTHER PITCHING MOMENT C/4	FTLB	0.0	0.0	0.0	
TOTAL PITCHING MOMENT C/4	FTLB	188111.1	-169401.3	-169401.3	

(f) 80 x 120 mode tabulated global design loads without vortex-, jet-, or propeller-wake effect for load cases considered.

Figure 45.- Continued.

CONSTANT INPUTS:		KNOTS	SPLITTER PLATE CD		SQ FT	0.025
TUNNEL SPEED	100.00	FAHREN.	TOTAL SPLITTER PLATE			2005.0
TEMP. AROUND TUNL CIRCUIT	60.0	PSF	AREA (PLANFORM)			
TEST SECTION Q	33.18	SLUG/FT3	NO. OF SPLITTER PLATES			2.0
MASS DENSITY AT VANE	0.002313					
DP/QL ROUGHNESS	0.04					
VANE SET FRONTAL AREA	9689.0	SQ FT				
INDIVID. VANE SPAN	75.4	FT				
NO. OF VANES	36.0	FT				
PITCH OF VANE SET	3.4	FT				
VANE CHORD	6.7	FT				
TOTAL VANE SPAN	2714.0					
CALCULATION						
ONSET ANGLE	55.0	DEG	55.0	45.0	45.0	45.0
OUTFLOW ANGLE	1.5	DEG	-2.5	2.5	-1.5	-1.5
BETA 1	29.4	DEG	29.4	19.4	19.4	19.4
BETA 2	-24.0	DEG	-28.0	-23.1	-27.1	-27.1
Q AT 0 DEG ONSET	36.9	PSF	36.9	36.9	36.9	36.9
VZ	168.5	FT/SEC	168.5	168.5	168.5	168.5
Q AT ONSET ANGLE	43.3	PSF	43.3	36.9	36.9	36.9
DP/QL VISCOUS DRAG COEFF	0.273		0.273	0.205	0.205	0.205
CM ABOUT 1/4 CHORD	0.036		0.036	-0.038	-0.038	-0.038
K1 (V/VAVG)2*A	1.000		1.000	1.000	1.000	1.000
QMAX/QAVG	1.000		1.000	1.000	1.000	1.000
F1	1.001		1.002	1.002	1.002	1.002
F2	0.974		0.884	1.051	1.027	1.027
F3	1.000		1.000	1.000	1.000	1.000
MOMENTUM LIFT	643618.6	LB	698858.9	496491.9	550863.6	550863.6
OTHER LIFT	0.0	LB	0.0	0.0	0.0	0.0
TOTAL LIFT	643618.6	LB	698858.9	496491.9	550863.6	550863.6
INVISCID DRAG	-36667.8	LB	-9448.8	19379.0	45047.5	45047.5
VISCOUS DRAG	114470.1	LB	114470.1	73333.8	73333.8	73333.8
INVISCID+VISCOUS DRAG	77802.3	LB	105021.3	92712.8	118381.4	118381.4
ROUGHNESS DRAG	16772.2	LB	16772.2	14309.0	14309.0	14309.0
SPLITTER PLATE DRAG	8676.9	LB	8676.9	7402.6	7402.6	7402.6
OTHER DRAG (VORTEX EFFECT)	17200.0	LB	17200.0	17200.0	17200.0	17200.0
TOTAL DRAG	120451.4	LB	147670.4	131624.5	157293.0	157293.0
PITCHING MOMENT C/4	188111.1	FTLB	188111.1	-169401.3	-169401.3	-169401.3
ROLLING MOMENT ABOUT VANE MIDSPAN FOR ONE VANE SPAN (75.4 FT)	±102000.0	FTLB	±102000.0	±102000.0	±102000.0	±102000.0

(g) 80 x 120 mode tabulated global design loads with vortex-wake effect for load cases considered.

Figure 45.- Continued.

CONSTANT INPUTS	KNOTS	SPLITTER PLATE CD	SQ FT	0.025
TUNNEL SPEED	100.00	TOTAL SPLITTER PLATE		2005.0
TEMP. AROUND TUNL CIRCUIT	50.0	AREA (PLANFORM)		
TEST SECTION Q	33.18	NO. OF SPLITTER PLATES		2.0
MASS DENSITY AT VANE	0.002370			
DP/QL ROUGHNESS	0.04			
VANE SET FRONTAL AREA	9689.0			
INDIVID. VANE SPAN	75.4			
NO. OF VANES	36.0			
PITCH OF VANE SET	3.4			
VANE CHORD	6.7			
TOTAL VANE SPAN	2714.0			
CALCULATION				
ONSET ANGLE	55.0	45.0	45.0	45.0
OUTFLOW ANGLE	1.5	2.5	-1.5	-1.5
BETA 1	29.4	19.4	19.4	19.4
BETA 2	-24.0	-23.1	-27.1	-27.1
Q AT 0 DEG ONSET	37.3	37.3	37.3	37.3
VZ	168.5	168.5	168.5	168.5
Q AT ONSET ANGLE	44.3	37.8	37.8	37.8
DP/QL VISCOUS DRAG COEFF	0.273	0.205	0.205	0.205
CM ABOUT 1/4 CHORD	0.036	0.038	0.038	0.038
K1 (V/VAVG)2*A	1.000	1.000	1.000	1.000
QMAX/QAVG	1.000	1.000	1.000	1.000
F1	1.075	1.075	1.075	1.075
F2	1.050	1.121	1.099	1.099
F3	1.075	1.075	1.075	1.075
MOMENTUM LIFT	708000.9	546207.5	606019.6	606019.6
OTHER LIFT	0.0	0.0	0.0	0.0
TOTAL LIFT	708000.9	546207.5	606019.6	606019.6
INVISCID DRAG	-40508.2	21176.8	49385.3	49385.3
VISCOUS DRAG	126111.3	80791.6	80791.6	80791.6
INVISCID+VISCOUS DRAG	85603.2	101968.4	130176.9	130176.9
ROUGHNESS DRAG	18477.9	15764.2	15764.2	15764.2
SPLITTER PLATE DRAG	9559.3	8155.5	8155.5	8155.5
OTHER DRAG	0.0	0.0	0.0	0.0
TOTAL DRAG	113640.3	125880.1	154096.6	154096.6
PITCHING MOMENT C/4	192746.8	-173575.9	-173575.9	-173575.9
OTHER PITCHING MOMENT C/4	0.0	0.0	0.0	0.0
TOTAL PITCHING MOMENT C/4	192746.8	-173575.9	-173575.9	-173575.9

(h) 80 x 120 mode tabulated global design loads with jet-wake effect for load cases considered.

Figure 45.- Continued.

CONSTANT INPUTS	KNOTS	SPLITTER PLATE CD	SQ FT	0.025
TUNNEL SPEED	100.00	TOTAL SPLITTER PLATE		2005.0
TEMP. AROUND TUNL CIRCUIT	60.0	AREA (PLANFORM)		
TEST SECTION Q	33.18	NO. OF SPLITTER PLATES		2.0
MASS DENSITY AT VANE	0.002370			
DP/QL ROUGHNESS	0.04			
VANE SET FRONTAL AREA	9689.0			
INDIVID. VANE SPAN	75.4			
NO. OF VANES	36.0			
PITCH OF VANE SET	3.4			
VANE CHORD	6.7			
TOTAL VANE SPAN	2714.0			
FAHREN.				
PSF				
SLUG/FT3				
SQ FT				
FT				
FT				
FT				
FT				
DEG	55.0	45.0	45.0	
DEG	1.5	2.5	-1.5	
DEG	29.4	19.4	19.4	
DEG	-24.0	-23.1	-27.1	
PSF	37.3	37.3	37.3	
FT/SEC	168.5	168.5	168.5	
PSF	44.3	37.8	37.8	
Q AT ONSET ANGLE	0.273	0.205	0.205	
DP/QL VISCOUS DRAG COEFF	0.036	-0.038	-0.038	
CM ABOUT 1/4 CHORD	1.000	1.000	1.000	
K1 (V/VAVG)^2*A	1.000	1.000	1.000	
QMAX/QAVG	1.083	1.083	1.083	
F1	1.057	1.130	1.107	
F2	1.083	1.083	1.083	
F3	1.083	1.083	1.083	
MOMENTUM LIFT	713125.5	550077.4	610318.4	
OTHER LIFT	0.0	0.0	0.0	
TOTAL LIFT	713125.5	550077.4	610318.4	
INVISCID DRAG	-40782.9	21336.5	49744.9	
VISCOUS DRAG	127002.8	81362.7	81362.7	
INVISCID+VISCOUS DRAG	86219.8	102699.3	131107.6	
ROUGHNESS DRAG	18608.5	15875.6	15875.6	
SPLITTER PLATE DRAG	9626.9	8213.1	8213.1	
OTHER DRAG	0.0	0.0	0.0	
TOTAL DRAG	114455.2	126788.0	155196.3	
PITCHING MOMENT C/4	192746.8	-173575.9	-173575.9	
OTHER PITCHING MOMENT C/4	0.0	0.0	0.0	
TOTAL PITCHING MOMENT C/4	192746.8	-173575.9	-173575.9	

(i) 80 x 120 mode tabulated global design loads with propeller-wake effect for load cases considered.

Figure 45.- Continued.

CONSTANT INPUTS			SPLITTER PLATE CD		
TUNNEL SPEED	300.00		TOTAL SPLITTER PLATE		0.025
TEMP. AROUND TUNL CIRCUIT	70.0		AREA (PLANFORM)		2005.0
TEST SECTION Q	262.44		NO. OF SPLITTER PLATES		2.0
MASS DENSITY AT VANE	0.002267				
DP/QL ROUGHNESS	0.04				
VANE SET FRONTAL AREA	9689.0				
INDIVID. VANE SPAN	75.4				
NO. OF VANES	36.0				
PITCH OF VANE SET	3.4				
VANE CHORD	6.7				
TOTAL VANE SPAN	2714.0				
CALCULATION					
ONSET ANGLE	3.0		3.0		-3.0
OUTFLOW ANGLE	1.3		-2.7		-3.5
BETA 1	-22.6		-22.6		-28.6
BETA 2	-24.3		-28.3		-29.1
Q AT Ø DEG ONSET	28.5		28.5		28.5
VZ	143.0		143.0		143.0
Q AT ONSET ANGLE	27.2		27.2		30.1
DP/QL VISCOUS DRAG COEFF	0.105		0.120		0.120
CM ABOUT 1/4 CHORD	-1.20		-1.20		-1.20
K1 (V/VAVG)2*A	1.051		1.051		1.051
QMAX/QAVG	1.000		1.000		1.000
F1	1.224		1.106		1.658
F2	1.291		1.132		1.838
F3	1.051		1.051		1.051
MOMENTUM LIFT	19614.7		60943.7		8469.1
OTHER LIFT	0.0		0.0		0.0
TOTAL LIFT	19614.7		60943.7		8469.1
INVISCID DRAG	8980.8		29768.3		5174.6
VISCOUS DRAG	29083.5		29083.5		36750.8
INVISCID+VISCOUS DRAG	38064.3		58851.7		41925.4
ROUGHNESS DRAG	11079.4		11079.4		12250.3
SPLITTER PLATE DRAG	5731.8		5731.8		6337.5
OTHER DRAG	0.0		0.0		0.0
TOTAL DRAG	54875.5		75662.9		60513.2
PITCHING MOMENT C/4	-414209.9		-414209.9		-457983.2

(J) 40 x 80 mode tabulated global design loads for load cases considered.
Figure 45.- Concluded.

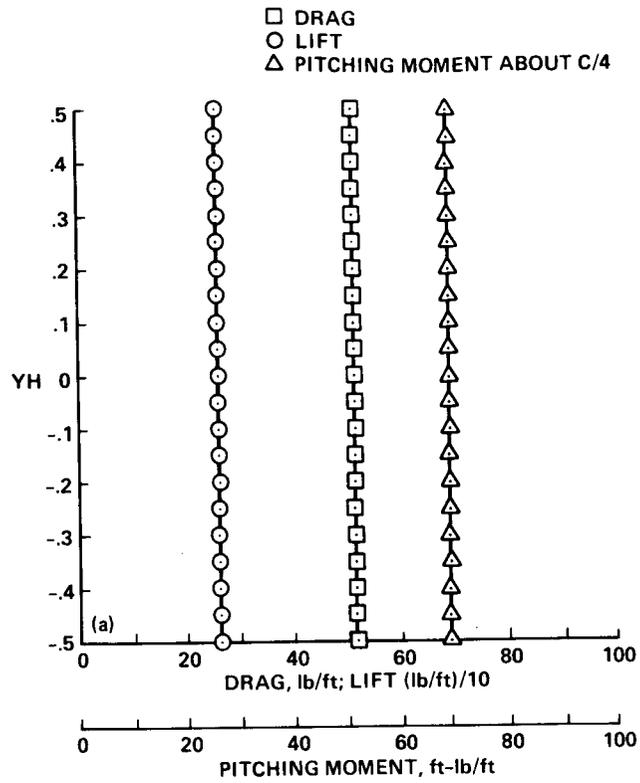

(a) No vortex-, jet-, or propeller-wake effects: $\epsilon_1 = 55^\circ$, $\epsilon_2 = -2.45^\circ$.

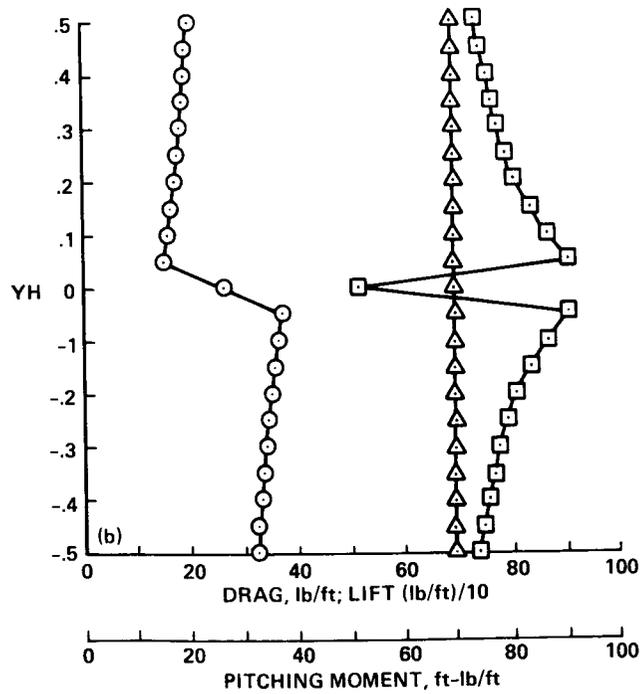

(b) Vortex wake center at vane midspan: $\epsilon_1 = 55^\circ$, $\epsilon_2 = -2.45^\circ$.

Figure 46.- Variation of local load with vane span for vane set 5; 80 x 120 mode.

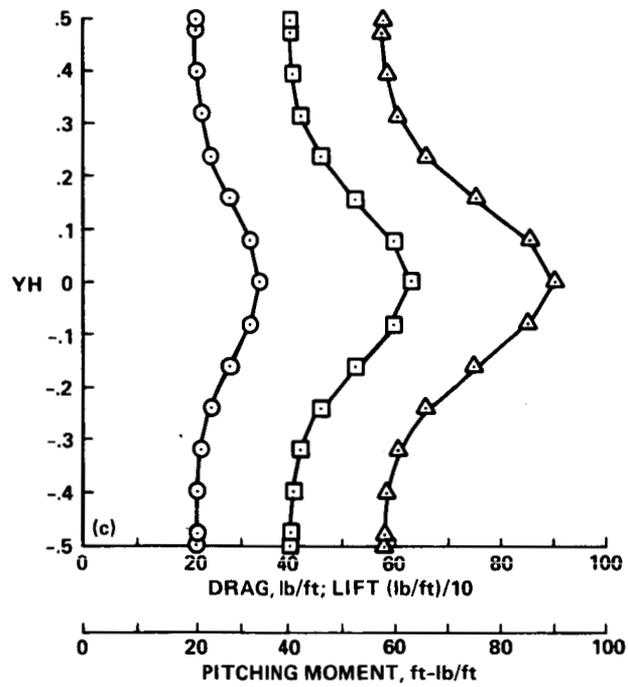

(c) Jet-wake effect at vane midspan: $\epsilon_1 = 55.0^\circ$, $\epsilon_2 = -2.45^\circ$.

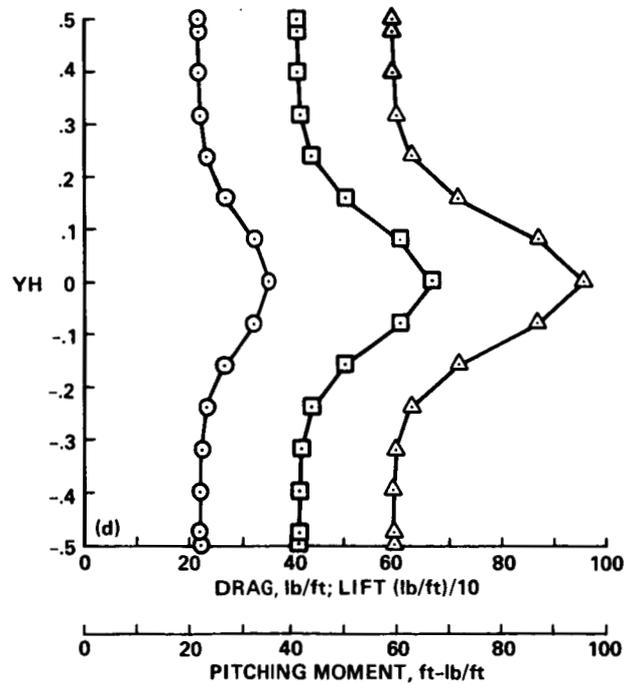

(d) Propeller-wake effect at vane midspan: $\epsilon_1 = 55.0^\circ$, $\epsilon_2 = -2.45^\circ$.

Figure 46.- Continued.

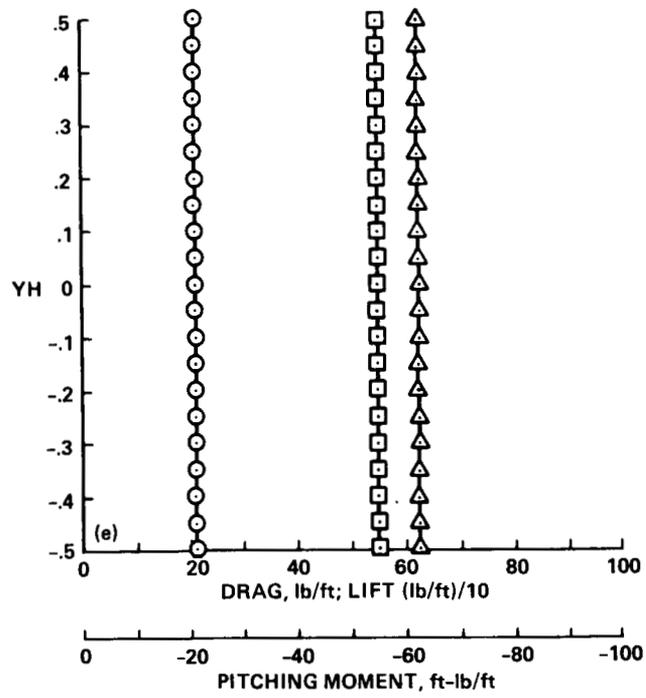

(e) No vortex-, jet-, or propeller-wake effects: $\epsilon_1 = 45.0^\circ$, $\epsilon_2 = -1.5^\circ$.

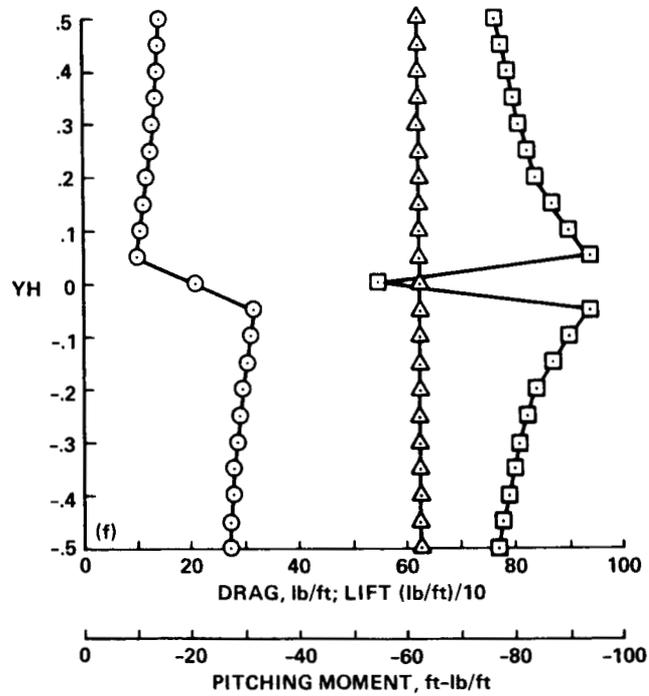

(f) Vortex-wake center at vane midspan: $\epsilon_1 = 45.0^\circ$, $\epsilon_2 = -1.5^\circ$.

Figure 46.- Continued.

OFS = DVOR = LVOR = 0.0

I	YFS	YH	DV	DI	DT	LI	LT	M
1	-37.7000	-0.5000	46.4650	5.0663	51.5313	262.6519	262.6519	69.3173
2	-33.9300	-0.4500	46.4650	5.0663	51.5313	262.6519	262.6519	69.3173
3	-30.1600	-0.4000	46.4650	5.0663	51.5313	262.6519	262.6519	69.3173
4	-26.3900	-0.3500	46.4650	5.0663	51.5313	262.6519	262.6519	69.3173
5	-22.6200	-0.3000	46.4650	5.0663	51.5313	262.6519	262.6519	69.3173
6	-18.8500	-0.2500	46.4650	5.0663	51.5313	262.6519	262.6519	69.3173
7	-15.0800	-0.2000	46.4650	5.0663	51.5313	262.6519	262.6519	69.3173
8	-11.3100	-0.1500	46.4650	5.0663	51.5313	262.6519	262.6519	69.3173
9	-7.5400	-0.1000	46.4650	5.0663	51.5313	262.6519	262.6519	69.3173
10	0.0000	0.0000	46.4650	5.0663	51.5313	262.6519	262.6519	69.3173
11	0.0000	0.0000	46.4650	5.0663	51.5313	262.6519	262.6519	69.3173
12	3.7700	0.0500	46.4650	5.0663	51.5313	262.6519	262.6519	69.3173
13	7.5400	0.1000	46.4650	5.0663	51.5313	262.6519	262.6519	69.3173
14	11.3100	0.1500	46.4650	5.0663	51.5313	262.6519	262.6519	69.3173
15	15.0800	0.2000	46.4650	5.0663	51.5313	262.6519	262.6519	69.3173
16	18.8500	0.2500	46.4650	5.0663	51.5313	262.6519	262.6519	69.3173
17	22.6200	0.3000	46.4650	5.0663	51.5313	262.6519	262.6519	69.3173
18	26.3900	0.3500	46.4650	5.0663	51.5313	262.6519	262.6519	69.3173
19	30.1600	0.4000	46.4650	5.0663	51.5313	262.6519	262.6519	69.3173
20	33.9300	0.4500	46.4650	5.0663	51.5313	262.6519	262.6519	69.3173
21	37.7000	0.5000	46.4650	5.0663	51.5313	262.6519	262.6519	69.3173

(g) No vortex-, jet-, or propeller-wake effect: $\epsilon_1 = 55.0^\circ$, $\epsilon_2 = -2.45^\circ$.

OFS = 0.0

I	YFS	YH	DV	DI	DVOR	DT	LI	LVOR	LT	M
1	-37.7000	-0.5000	46.4650	5.0663	22.0000	73.5313	262.6519	61.0000	323.6519	69.3173
2	-33.9300	-0.4500	46.4650	5.0663	23.0000	74.5313	262.6519	64.5000	327.1519	69.3173
3	-30.1600	-0.4000	46.4650	5.0663	24.0000	75.5313	262.6519	68.0000	330.6519	69.3173
4	-26.3900	-0.3500	46.4650	5.0663	25.0000	76.5313	262.6519	72.0000	334.1519	69.3173
5	-22.6200	-0.3000	46.4650	5.0663	26.0000	77.5313	262.6519	76.0000	338.6519	69.3173
6	-18.8500	-0.2500	46.4650	5.0663	27.5000	79.0313	262.6519	81.5000	344.1519	69.3173
7	-15.0800	-0.2000	46.4650	5.0663	29.0000	80.5313	262.6519	87.0000	349.6519	69.3173
8	-11.3100	-0.1500	46.4650	5.0663	32.0000	83.5313	262.6519	94.5000	357.1519	69.3173
9	-7.5400	-0.1000	46.4650	5.0663	35.0000	86.5313	262.6519	102.0000	364.6519	69.3173
10	-3.7700	0.0500	46.4650	5.0663	39.0000	90.5313	262.6519	109.0000	371.6519	69.3173
11	0.0000	0.0000	46.4650	5.0663	0.0001	51.5313	262.6519	-0.0002	262.6517	69.3173
12	3.7700	0.0500	46.4650	5.0663	39.0000	90.5313	262.6519	-109.0000	153.6519	69.3173
13	7.5400	0.1000	46.4650	5.0663	35.0000	86.5313	262.6519	-102.0000	160.6520	69.3173
14	11.3100	0.1500	46.4650	5.0663	32.0000	83.5313	262.6519	-94.5000	168.1520	69.3173
15	15.0800	0.2000	46.4650	5.0663	29.0000	80.5313	262.6519	-87.0000	175.6519	69.3173
16	18.8500	0.2500	46.4650	5.0663	27.5000	79.0313	262.6519	-81.5000	181.1519	69.3173
17	22.6200	0.3000	46.4650	5.0663	26.0000	77.5313	262.6519	-76.0000	186.6519	69.3173
18	26.3900	0.3500	46.4650	5.0663	25.0000	76.5313	262.6519	-72.0000	190.6519	69.3173
19	30.1600	0.4000	46.4650	5.0663	24.0000	75.5313	262.6519	-68.0000	194.6519	69.3173
20	33.9300	0.4500	46.4650	5.0663	23.0000	74.5313	262.6519	-64.5000	198.1520	69.3173
21	37.7000	0.5000	46.4650	5.0663	22.0000	73.5313	262.6519	-61.0000	201.6519	69.3173

(h) Vortex-wake center at vane midspan: $\epsilon_1 = 55.0^\circ$, $\epsilon_2 = 2.45^\circ$.

Figure 46.- Continued.

DDT = DJTRUSS = LLT = LJTRUSS = MJTRUSS = 0.0

I	YFS	YH-YJH	QJET	DV	DI	DT	LI	LT
1	-37.7000	-0.5000	36.0700	38.7244	1.6132	40.3376	214.4768	214.4768
2	-35.9658	-0.4770	36.1800	38.8425	1.6181	40.4606	215.1309	215.1309
3	-30.0092	-0.3980	36.5100	39.1968	1.6329	40.8297	217.0931	217.0931
4	-23.9772	-0.3180	37.8300	40.6139	1.6919	42.3059	224.9420	224.9420
5	-18.0206	-0.2390	41.0300	44.0494	1.8351	45.8845	243.9696	243.9696
6	-11.9886	-0.1590	46.7700	50.2118	2.0918	52.3036	278.1003	278.1003
7	-6.0320	-0.0800	53.2800	57.2009	2.3829	59.5838	316.8096	316.8096
8	0.0000	0.0000	56.2500	60.3894	2.5158	62.9052	334.4696	334.4696
9	6.0320	0.0800	53.2800	57.2009	2.3829	59.5838	316.8096	316.8096
10	11.9886	0.1590	46.7700	50.2118	2.0918	52.3036	278.1003	278.1003
11	18.0206	0.2390	41.0300	44.0494	1.8351	45.8845	243.9696	243.9696
12	23.9772	0.3180	37.8300	40.6139	1.6919	42.3059	224.9420	224.9420
13	30.0092	0.3980	36.5100	39.1968	1.6329	40.8297	217.0931	217.0931
14	35.9658	0.4770	36.1800	38.8425	1.6181	40.4606	215.1309	215.1309
15	37.7000	0.5000	36.0700	38.7244	1.6132	40.3376	214.4768	214.4768

I	YFS	YH-YJH	QJET	MM	MT
1	-37.7000	-0.5000	36.0700	57.7697	57.7697
2	-35.9658	-0.4770	36.1800	57.9459	57.9459
3	-30.0092	-0.3980	36.5100	58.4744	58.4744
4	-23.9772	-0.3180	37.8300	60.5885	60.5885
5	-18.0206	-0.2390	41.0300	65.7137	65.7137
6	-11.9886	-0.1590	46.7700	74.9068	74.9068
7	-6.0320	-0.0800	53.2800	85.3333	85.3333
8	0.0000	0.0000	56.2500	90.0900	90.0900
9	6.0320	0.0800	53.2800	85.3333	85.3333
10	11.9886	0.1590	46.7700	74.9068	74.9068
11	18.0206	0.2390	41.0300	65.7137	65.7137
12	23.9772	0.3180	37.8300	60.5885	60.5885
13	30.0092	0.3980	36.5100	58.4744	58.4744
14	35.9658	0.4770	36.1800	57.9459	57.9459
15	37.7000	0.5000	36.0700	57.7697	57.7697

(i) Jet-wake effect at vane midspan: $\epsilon_1 = 55.0^\circ$, $\epsilon_2 = 2.45^\circ$.

Figure 46.- Continued.

DDT = DJTRUSS = LLT = LJTRUSS = MJTRUSS = 0.0

I	YFS	YH-YJH	QJET	DV	DI	DT	LI	LT
1	-37.7000	-0.5000	37.1700	39.9053	1.6624	41.5678	221.0175	221.0175
2	-35.9658	-0.4770	37.1700	39.9053	1.6624	41.5678	221.0175	221.0175
3	-30.0092	-0.3980	37.1700	39.9053	1.6624	41.5678	221.0175	221.0175
4	-23.9772	-0.3180	37.5000	40.2596	1.6772	41.9368	222.9797	222.9797
5	-18.0206	-0.2390	39.2700	42.1599	1.7563	43.9162	233.5044	233.5044
6	-11.9886	-0.1590	44.7800	48.0754	2.0028	50.0781	266.2675	266.2675
7	-6.0320	-0.0800	54.2700	58.2637	2.4272	60.6910	322.6963	322.6963
8	0.0000	0.0000	59.7800	64.1792	2.6737	66.8529	355.4594	355.4594
9	6.0320	0.0800	54.2700	58.2637	2.4272	60.6910	322.6963	322.6963
10	11.9886	0.1590	44.7800	48.0754	2.0028	50.0781	266.2675	266.2675
11	18.0206	0.2390	39.2700	42.1599	1.7563	43.9162	233.5044	233.5044
12	23.9772	0.3180	37.5000	40.2596	1.6772	41.9368	222.9797	222.9797
13	30.0092	0.3980	37.1700	39.9053	1.6624	41.5678	221.0175	221.0175
14	35.9658	0.4770	37.1700	39.9053	1.6624	41.5678	221.0175	221.0175
15	37.7000	0.5000	37.1700	39.9053	1.6624	41.5678	221.0175	221.0175

I	YFS	YH-YJH	QJET	MM	MT
1	-37.7000	-0.5000	37.1700	59.5315	59.5315
2	-35.9658	-0.4770	37.1700	59.5315	59.5315
3	-30.0092	-0.3980	37.1700	59.5315	59.5315
4	-23.9772	-0.3180	37.5000	60.0600	60.0600
5	-18.0206	-0.2390	39.2700	62.8948	62.8948
6	-11.9886	-0.1590	44.7800	71.7197	71.7197
7	-6.0320	-0.0800	54.2700	86.9188	86.9188
8	0.0000	0.0000	59.7800	95.7437	95.7437
9	6.0320	0.0800	54.2700	86.9188	86.9188
10	11.9886	0.1590	44.7800	71.7197	71.7197
11	18.0206	0.2390	39.2700	62.8948	62.8948
12	23.9772	0.3180	37.5000	60.0600	60.0600
13	30.0092	0.3980	37.1700	59.5315	59.5315
14	35.9658	0.4770	37.1700	59.5315	59.5315
15	37.7000	0.5000	37.1700	59.5315	59.5315

(j) Propeller-wake effect at vane midspan: $\epsilon_1 = 55.0^\circ$, $\epsilon_2 = 2.45^\circ$.

Figure 46.- Continued.

QFS = DVOR = LVOR = 0.0

I	YFS	YH	DV	DI	DT	LI	LT	M
1	-37.7000	-0.5000	31.0257	23.8864	54.9121	209.9682	209.9682	-62.4161
2	-33.9300	-0.4500	31.0257	23.8864	54.9121	209.9682	209.9682	-62.4161
3	-30.1600	-0.4000	31.0257	23.8864	54.9121	209.9682	209.9682	-62.4161
4	-26.3900	-0.3500	31.0257	23.8864	54.9121	209.9682	209.9682	-62.4161
5	-22.6200	-0.3000	31.0257	23.8864	54.9121	209.9682	209.9682	-62.4161
6	-18.8500	-0.2500	31.0257	23.8864	54.9121	209.9682	209.9682	-62.4161
7	-15.0800	-0.2000	31.0257	23.8864	54.9121	209.9682	209.9682	-62.4161
8	-11.3100	-0.1500	31.0257	23.8864	54.9121	209.9682	209.9682	-62.4161
9	-7.5400	-0.1000	31.0257	23.8864	54.9121	209.9682	209.9682	-62.4161
10	-3.7700	-0.0500	31.0257	23.8864	54.9121	209.9682	209.9682	-62.4161
11	0.0000	0.0000	31.0257	23.8864	54.9121	209.9682	209.9682	-62.4161
12	3.7700	0.0500	31.0257	23.8864	54.9121	209.9682	209.9682	-62.4161
13	7.5400	0.1000	31.0257	23.8864	54.9121	209.9682	209.9682	-62.4161
14	11.3100	0.1500	31.0257	23.8864	54.9121	209.9682	209.9682	-62.4161
15	15.0800	0.2000	31.0257	23.8864	54.9121	209.9682	209.9682	-62.4161
16	18.8500	0.2500	31.0257	23.8864	54.9121	209.9682	209.9682	-62.4161
17	22.6200	0.3000	31.0257	23.8864	54.9121	209.9682	209.9682	-62.4161
18	26.3900	0.3500	31.0257	23.8864	54.9121	209.9682	209.9682	-62.4161
19	30.1600	0.4000	31.0257	23.8864	54.9121	209.9682	209.9682	-62.4161
20	33.9300	0.4500	31.0257	23.8864	54.9121	209.9682	209.9682	-62.4161
21	37.7000	0.5000	31.0257	23.8864	54.9121	209.9682	209.9682	-62.4161

(k) No vortex-, jet-, or propeller-wake effects: $\epsilon_1 = 45.0^\circ$, $\epsilon_2 = -1.5^\circ$.

QFS = 0.0

I	YFS	YH	DV	DI	DVOR	DT	LI	LVOR	LT	M
1	-37.7000	-0.5000	31.0257	23.8864	22.0000	76.9121	209.9682	61.0000	270.9682	-62.4161
2	-33.9300	-0.4500	31.0257	23.8864	23.0000	77.9121	209.9682	64.5000	274.4682	-62.4161
3	-30.1600	-0.4000	31.0257	23.8864	24.0000	78.9121	209.9682	68.0000	277.9682	-62.4161
4	-26.3900	-0.3500	31.0257	23.8864	25.0000	79.9121	209.9682	72.0000	281.9682	-62.4161
5	-22.6200	-0.3000	31.0257	23.8864	26.0000	80.9121	209.9682	76.0000	285.9682	-62.4161
6	-18.8500	-0.2500	31.0257	23.8864	27.0000	82.4121	209.9682	81.5000	291.4682	-62.4161
7	-15.0800	-0.2000	31.0257	23.8864	29.0000	83.9121	209.9682	87.0000	296.9682	-62.4161
8	-11.3100	-0.1500	31.0257	23.8864	32.0000	86.9121	209.9682	94.5000	304.4682	-62.4161
9	-7.5400	-0.1000	31.0257	23.8864	35.0000	89.9121	209.9682	102.0000	311.9682	-62.4161
10	-3.7700	-0.0500	31.0257	23.8864	39.0000	93.9121	209.9682	109.0000	318.9682	-62.4161
11	0.0000	0.0000	31.0257	23.8864	0.0001	54.9122	209.9682	-0.0002	209.9679	-62.4161
12	3.7700	0.0500	31.0257	23.8864	39.0000	93.9121	209.9682	-109.0000	100.9682	-62.4161
13	7.5400	0.1000	31.0257	23.8864	35.0000	89.9121	209.9682	-102.0000	107.9682	-62.4161
14	11.3100	0.1500	31.0257	23.8864	32.0000	86.9121	209.9682	-94.5000	115.4682	-62.4161
15	15.0800	0.2000	31.0257	23.8864	29.0000	83.9121	209.9682	-87.0000	122.9682	-62.4161
16	18.8500	0.2500	31.0257	23.8864	27.5000	82.4121	209.9682	-81.5000	128.4682	-62.4161
17	22.6200	0.3000	31.0257	23.8864	26.0000	80.9121	209.9682	-76.0000	133.9682	-62.4161
18	26.3900	0.3500	31.0257	23.8864	25.0000	79.9121	209.9682	-72.0000	137.9682	-62.4161
19	30.1600	0.4000	31.0257	23.8864	24.0000	78.9121	209.9682	-68.0000	141.9682	-62.4161
20	33.9300	0.4500	31.0257	23.8864	23.0000	77.9121	209.9682	-64.5000	145.4682	-62.4161
21	37.7000	0.5000	31.0257	23.8864	22.0000	76.9121	209.9682	-61.0000	148.9682	-62.4161

(l) Vortex-wake center at vane midspan: $\epsilon_1 = 45.0^\circ$, $\epsilon_2 = -1.5^\circ$.

Figure 46.- Continued.

ϵ_1 , deg	Lift, lb/ft span	Drag, lb/ft span	Pitching moment, ft-lb/ft span	q , lb/ft ²	Vane chord, ft
45	355	109	-169	36.92	6.67

Note:

1. Lift, drag, and pitching moment based on c_l , c_d , c_m , shown on figure 22(e), respectively.
2. Loads acting at $1/4$ c and pitching moment about $1/4$ c.
3. Lift acting along vane set stagger line with positive direction toward east wall.
4. Drag perpendicular to vane set.
5. Uniform lift, drag, and pitching moment from floor to ceiling.

(m) 80 x 120 mode corner vane loads with no vortex-, jet-, or propeller-wakes.

Figure 46.- Concluded.

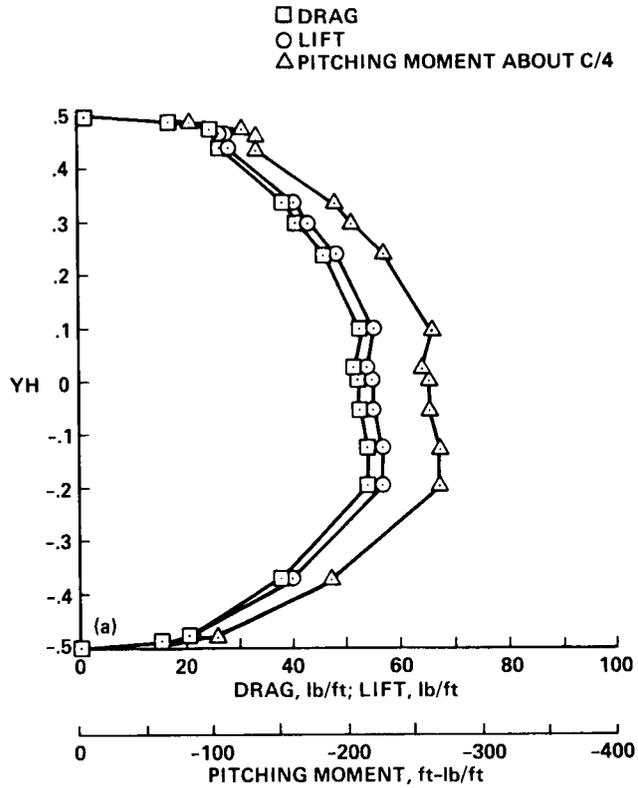

(a) $\epsilon_1 = 3.0^\circ$, $\epsilon_2 = -2.72^\circ$.

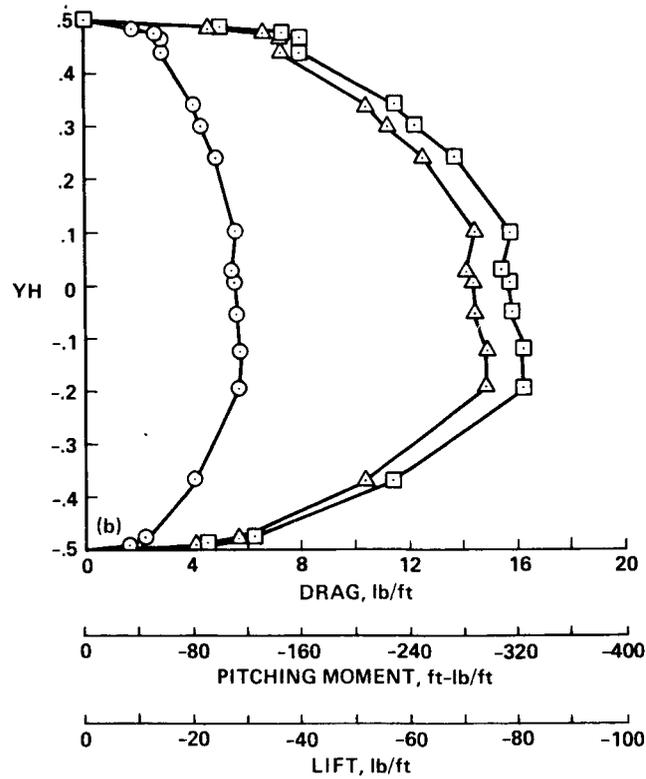

(b) $\epsilon_1 = -3.0^\circ$, $\epsilon_2 = 0.5^\circ$.

Figure 47.- Variation of local load with vane span for vane set 5; 40 x 80 mode.

DVOR = LVOR = 0.0

I	YFS	YH	QFS	DV	DI	DT	LI	LT	M
1	-37.7000	-0.5000	0.0000	0.0000	0.0000	0.0000	0.0000	0.0000	0.0000
2	-37.2476	-0.4940	13.9581	6.9421	8.0381	14.9802	15.6880	15.6880	-74.5176
3	-36.1166	-0.4790	19.2724	9.5851	11.0985	20.6836	21.6610	21.6610	-102.8890
4	-27.9734	-0.3710	35.4075	17.6099	20.3903	38.0002	39.7957	39.7957	-189.0287
5	-14.6276	-0.1940	50.3900	25.0615	29.0184	54.0798	56.6352	56.6352	-269.0155
6	-9.3496	-0.1240	50.4540	25.0933	29.0552	54.1486	56.7071	56.7071	-269.3573
7	-3.9962	-0.0530	48.9814	24.3609	28.2072	52.5681	55.0520	55.0520	-261.4954
8	0.4524	0.0060	48.8533	24.2972	28.1334	52.4306	54.9080	54.9080	-260.8117
9	2.0358	0.0270	48.0210	23.8832	27.6541	52.4306	53.9725	53.9725	-256.3680
10	7.5400	0.1000	49.1094	24.4246	28.2809	52.7055	55.1959	55.1959	-262.1790
11	18.1714	0.2410	42.7707	21.2720	24.6306	45.9026	48.0715	48.0715	-228.3385
12	22.6200	0.3000	38.2887	19.0429	22.0495	41.0924	43.0341	43.0341	-204.4108
13	25.5606	0.3390	35.8557	17.8328	20.6484	38.4812	40.2995	40.2995	-191.4214
14	33.1006	0.4390	24.9709	12.4193	14.3801	26.7994	28.0657	28.0657	-133.3114
15	35.0610	0.4650	24.9709	12.4193	14.3801	26.7994	28.0657	28.0657	-133.3114
16	35.8904	0.4760	22.9220	11.4003	13.2002	24.6005	25.7629	25.7629	-122.3730
17	36.7952	0.4880	15.8789	7.8974	9.1443	17.0417	17.8469	17.8469	-84.7724
18	37.7000	0.5000	0.0000	0.0000	0.0000	0.0000	0.0000	0.0000	0.0000

(c) $\epsilon_1 = 3.0^\circ$, $\epsilon_2 = -2.72^\circ$.

DVOR = LVOR = 0.0

I	YFS	YH	QFS	DV	DI	DT	LI	LT	M
1	-37.7000	-0.5000	0.0000	0.0000	0.0000	0.0000	0.0000	0.0000	0.0000
2	-37.2476	-0.4940	15.4332	8.4697	-3.9649	4.5048	-7.9894	-7.9894	-82.3926
3	-36.1166	-0.4790	21.3091	11.6944	-5.4745	6.2199	-11.0313	-11.0313	-113.7622
4	-27.9734	-0.3710	39.1493	21.4851	-10.0578	11.4273	-20.2668	-20.2668	-209.0050
5	-14.6276	-0.1940	55.7152	30.5765	-14.3137	16.2628	-28.8426	-28.8426	-297.4447
6	-9.3496	-0.1240	55.7860	30.6153	-14.3319	16.2834	-28.8793	-28.8793	-297.8227
7	-3.9962	-0.0530	54.1577	29.7217	-13.9136	15.8081	-28.0364	-28.0364	-289.1299
8	0.4524	0.0060	54.0161	29.6440	-13.8772	15.7668	-27.9631	-27.9631	-288.3740
9	2.0358	0.0270	53.0958	29.1390	-13.6408	15.4982	-27.4866	-27.4866	-283.4607
10	7.5400	0.1000	54.2993	29.7994	-13.9500	15.8495	-28.1097	-28.1097	-289.8858
11	18.1714	0.2410	47.2906	25.9531	-12.1494	13.8037	-24.4814	-24.4814	-252.4690
12	22.6200	0.3000	42.3350	23.2335	-10.8762	12.3572	-21.9160	-21.9160	-226.0126
13	25.5606	0.3390	39.6448	21.7571	-10.1851	11.5720	-20.5233	-20.5233	-211.6506
14	33.1006	0.4390	27.6098	15.1523	-7.0932	8.0591	-14.2930	-14.2930	-147.3996
15	35.0610	0.4650	27.6098	15.1523	-7.0932	8.0591	-14.2930	-14.2930	-147.3996
16	35.8904	0.4760	25.3444	13.9090	-6.5112	7.3978	-13.1203	-13.1203	-135.3052
17	36.7952	0.4880	17.5570	9.6353	-4.5106	5.1247	-9.0889	-9.0889	-93.7310
18	37.7000	0.5000	0.0000	0.0000	0.0000	0.0000	0.0000	0.0000	0.0000

(d) $\epsilon_1 = -3.0^\circ$, $\epsilon_2 = 0.5^\circ$.

Figure 47.- Concluded.

		40 by 80 mode		80 by 120 mode
Global load (total vane span = 7552.0 ft)		Case 1	Case 2	Case 1
Onset angle	deg	3.4	-3.4	3.4
Outflow angle	deg	-3.0	-3.0	0.0
Lift	lb	309500.	276500.	23500.
Drag	lb	129900.	153700.	55600.
Pitching moment about 1/4 vane chord	ft-lb	-2323900.	-2790600.	1515700.

Fixed vane local load based on above condition (see figure 49)

Lift/vane span	lb/ft			17.0
Drag/vane span	lb/ft			-9.0
Pitching moment lift/vane span	ft-lb/ft			4.0

Trailing edge flap (flap chord = lift)

Flap deflection	deg	80.	80.	0.0
Normal force/span	lb/ft	52.	60.	-21.
Hinge moment/span	ft-lb/ft	-142.	-151.	44.

Note:

1. Loads acting at 1/4 vane chord.
2. Lift acting along vane set. Positive direction toward outside wall.
3. Drag perpendicular to vane set.
4. See figures for vane spanwise loads.

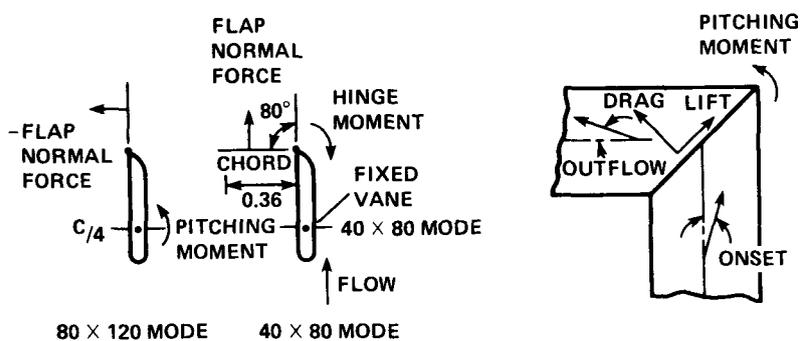

(a) Maximum global design load.

Figure 48.- Global design and operating loads for vane set 6.

40 by 80 mode 80 by 120 mode

Global load (total vane span = 7552.0 ft)		Case 1	Case 1
Onset angle	deg	0.0	0.0
Outflow angle	deg	0.0	0.0
Lift	lb	276700.	0.0
Drag	lb	126300.	71000.
Pitching moment about 1/4 vane chord	ft-lb	-2575300.	1336200.

Fixed vane local load based on above condition

Lift/vane span	lb/ft	11.
Drag/vane span	lb/ft	-3.
Pitching moment/ vane span	pt-lb/ft	31.

Trailing edge flap (flap chord = 6 ft)

Flap deflection		80°	0°
Normal force/span	lb/ft	55.	-16.
Hinge moment/span	ft-lb/ft	-144.	34.

Note:

1. Loads acting at 1/4 vane chord.
2. Lift acting along vane set. Positive direction toward outside wall
3. Drag perpendicular to vane set.

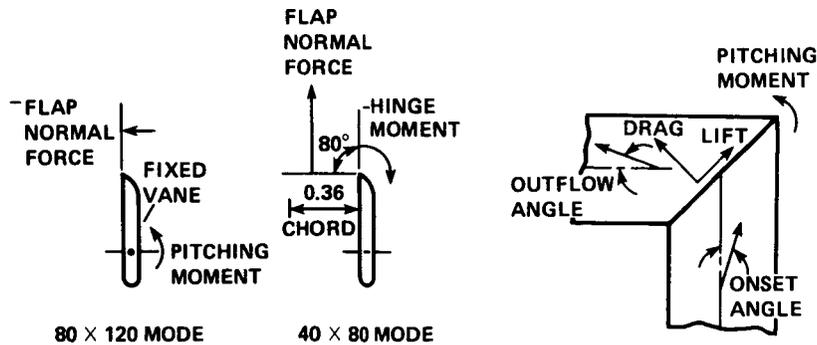

(b) Global operating loads.

Figure 48.- Continued.

VANE 6 DESIGN GLOBAL AND LOCAL LOADS
40 BY 80 MODE

CONSTANT INPUTS	KNOTS	SPLITTER PLATE CD	SQ FT	0.025
TUNNEL SPEED	300.00	TOTAL SPLITTER PLATE		7518.0
TEMP. AROUND TUNL CIRCUIT	70.0	AREA (PLANFORM)		11.0
TEST SECTION Q	262.44	NO. OF SPLITTER PLATES		
MASS DENSITY AT VANE	0.002347			
DP/QL ROUGHNESS	0.004			
VANE SET FRONTAL AREA	32323.0			
INDIVID. VANE SPAN	132.5			
NO. OF VANES	57.0			
PITCH OF VANE SET	4.2			
VANE CHORD	17.2			
TOTAL VANE SPAN	7552.0			
CALCULATION				
ONSET ANGLE	3.4	-3.4	-3.4	
OUTFLOW ANGLE	3.0	3.0	-3.0	
BETA 1	48.4	41.6	41.6	
BETA 2	-42.0	-42.0	-42.0	
Q AT 0 DEG ONSET	4.0	4.0	4.0	
VZ	41.4	41.4	41.4	
Q AT ONSET ANGLE	4.6	3.6	3.6	
DP/QL VISCOUS DRAG COEFF	0.780	0.930	0.930	
CM ABOUT 1/4 CHORD	-214	-326	-326	
K1 (V/VAVG)2*A	1.064	1.064	1.064	
QMAX/QAVG	1.816	1.816	1.816	
MOMENTUM LIFT	280390.4	247396.8	276478.3	
OTHER LIFT	0.0	0.0	0.0	
TOTAL LIFT	280390.4	247396.8	276478.3	
INVISCID DRAG	-31673.3	1554.0	30795.7	
VISCOUS DRAG	122403.0	115040.6	115040.6	
INVISCID+VISCOUS DRAG	90729.7	116594.6	145836.3	
ROUGHNESS DRAG	6277.1	4948.0	4948.0	
SPLITTER PLATE DRAG	3650.0	2877.1	2877.1	
OTHER DRAG	0.0	0.0	0.0	
TOTAL DRAG	100656.7	124419.7	153661.4	
PITCHING MOMENT C/4	-2323930.5	-2790602.8	-2790602.8	

(c) 40 x 80 mode tabulated global loads for load cases considered.

Figure 48.- Concluded.

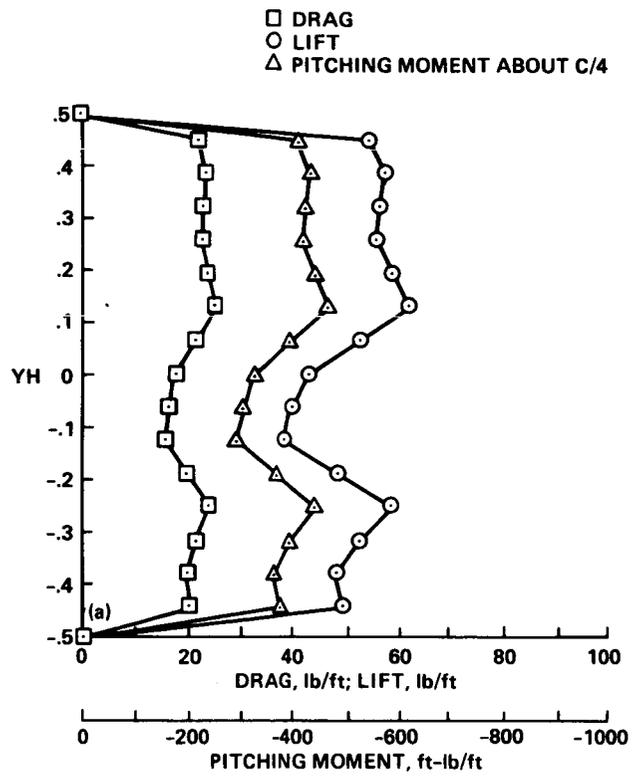
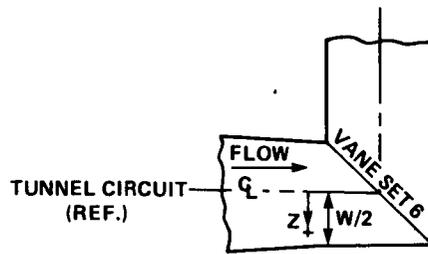

(a) $\epsilon_1 = 3.4^\circ$, $\epsilon_2 = -3.0^\circ$, $z/w = 0.10$.

Figure 49.- Variation of local design load with vane span for vane set 6; 40 x 80 mode.

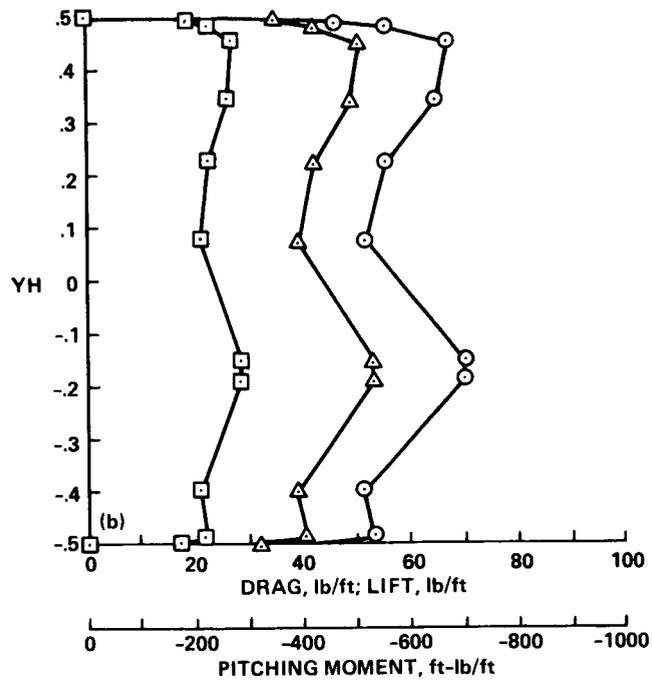

(b) $\epsilon_1 = 3.4^\circ$, $\epsilon_2 = -3.0^\circ$, $z/w = 0.414$.

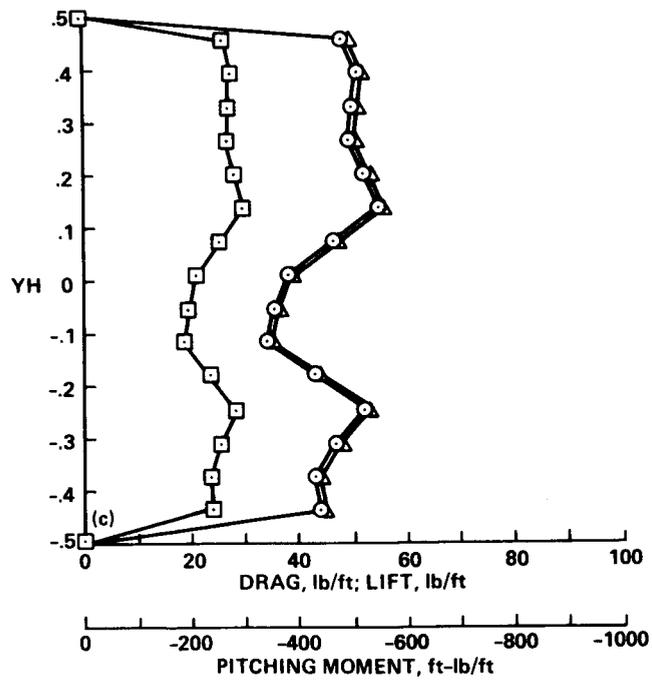

(c) $\epsilon_1 = -3.4^\circ$, $\epsilon_2 = -3.0^\circ$, $z/w = 0.100$.

Figure 49.- Continued.

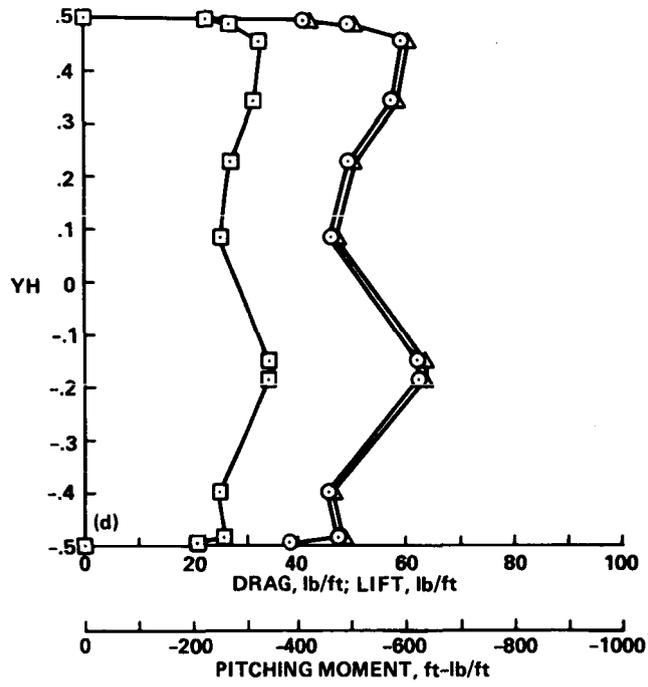

(d) $\epsilon_1 = -3.4^\circ$, $\epsilon_2 = -3.0^\circ$, $z/w = 0.414$.

Figure 49.- Continued.

DVOR = LVOR = 0.0

I	YFS	YH	QFS	DV	DI	DT	LI	LT	M
1	-66.2500	-0.5000	0.0000	0.0000	0.0000	0.0000	0.0000	0.0000	0.0000
2	-57.8105	-0.4363	5.8998	20.5125	-0.3876	20.1248	49.3319	49.3319	-373.9500
3	-49.3710	-0.3726	5.7523	19.9996	-0.3779	19.6217	48.0986	48.0986	-364.6012
4	-40.9315	-0.3089	6.2685	21.7945	-0.4118	21.3826	52.4151	52.4151	-397.3220
5	-32.4920	-0.2452	7.0060	24.3585	-0.4603	23.8983	58.5816	58.5816	-444.0657
6	-24.0525	-0.1815	5.7523	19.9996	-0.3779	19.6217	48.0986	48.0986	-364.6012
7	-15.6131	-0.1178	4.5724	15.8972	-0.3004	15.5968	38.2322	38.2322	-289.8113
8	-7.1736	-0.0541	4.7936	16.6664	-0.3149	16.3514	40.0821	40.0821	-303.8343
9	1.2659	0.0096	5.1623	17.9484	-0.3392	17.6992	43.1654	43.1654	-327.2062
10	9.7054	0.0732	6.2685	21.7945	-0.4118	21.3826	52.4151	52.4151	-397.3220
11	18.1449	0.1369	7.3748	25.6406	-0.4845	25.1561	61.6649	61.6649	-467.4377
12	26.5844	0.2006	7.0060	24.3585	-0.4603	23.8983	58.5816	58.5816	-444.0657
13	35.0239	0.2643	6.6373	23.0765	-0.4361	22.6404	55.4984	55.4984	-420.6937
14	43.4634	0.3280	6.7110	23.3329	-0.4409	22.8920	56.1150	56.1150	-425.3682
15	51.9029	0.3917	6.8585	23.8457	-0.4506	23.3951	57.3483	57.3483	-434.7169
16	60.3424	0.4554	6.4898	22.5637	-0.4264	22.1373	54.2651	54.2651	-411.3450
17	66.2500	0.5000	0.0000	0.0000	0.0000	0.0000	0.0000	0.0000	0.0000

(e) Tabulated data, $\epsilon_1 = 3.4^\circ$, $\epsilon_2 = -3.0^\circ$, $z/w = 0.100$.

DVOR = LVOR = 0.0

I	YFS	YH	QFS	DV	DI	DT	LI	LT	M
1	-66.2500	-0.5000	0.0000	0.0000	0.0000	0.0000	0.0000	0.0000	0.0000
2	-65.5875	-0.4950	5.0886	17.6920	-0.3343	17.3577	42.5488	42.5488	-322.5320
3	-64.2625	-0.4850	6.3792	22.1791	-0.4191	21.7600	53.3401	53.3401	-404.3336
4	-52.7350	-0.3980	6.1211	21.2817	-0.4022	20.8795	51.1819	51.1819	-387.9733
5	-24.1150	-0.1820	8.3704	29.1021	-0.5499	28.5521	69.9896	69.9896	-530.5417
6	-19.8750	-0.1500	8.3704	29.1021	-0.5499	28.5521	69.9896	69.9896	-530.5417
7	10.6000	0.0800	6.1948	21.5381	-0.4070	21.1311	51.7985	51.7985	-392.6476
8	29.8125	0.2250	6.6373	23.0765	-0.4361	22.6405	55.4984	55.4984	-420.6939
9	45.1825	0.3410	7.7435	26.9226	-0.5087	26.4139	64.7481	64.7481	-490.8095
10	60.2875	0.4550	8.0016	27.8200	-0.5257	27.2943	66.9064	66.9064	-507.1698
11	64.3950	0.4860	6.6373	23.0765	-0.4361	22.6405	55.4984	55.4984	-420.6939
12	65.4550	0.4940	5.5311	19.2304	-0.3634	18.8670	46.2487	46.2487	-350.5782
13	66.2500	0.5000	0.0000	0.0000	0.0000	0.0000	0.0000	0.0000	0.0000

(f) Tabulated data, $\epsilon_1 = 3.4^\circ$, $\epsilon_2 = -3.0^\circ$, $z/w = 0.414$.

Figure 49.- Continued.

DVOR = LVOR = 0.0

I	YFS	YH	QFS	DV	DI	DT	LI	LT	M
1	-66.2500	-0.5000	0.0000	0.0000	0.0000	0.0000	0.0000	0.0000	0.0000
2	-57.8105	-0.4363	4.6506	19.1270	4.9090	24.0360	44.0725	44.0725	-449.0433
3	-49.3710	-0.3726	4.5343	18.6488	4.7863	23.4351	42.9707	42.9707	-437.8173
4	-40.9315	-0.3089	4.9413	20.3224	5.2159	25.5383	46.8270	46.8270	-477.1087
5	-32.4920	-0.2452	5.5226	22.7133	5.8295	28.5428	52.3361	52.3361	-533.2390
6	-24.0525	-0.1815	4.5343	18.6488	4.7863	23.4351	42.9707	42.9707	-437.8173
7	-15.6131	-0.1178	3.6042	14.8234	3.8045	18.6279	34.1562	34.1562	-348.0087
8	-7.1736	-0.0541	3.7786	15.5407	3.9886	19.5293	35.8089	35.8089	-364.8476
9	1.2659	0.0096	4.0693	16.7361	4.2954	21.0315	38.5634	38.5634	-392.9129
10	9.7054	0.0732	4.9413	20.3224	5.2159	25.5383	46.8270	46.8270	-477.1087
11	18.1449	0.1369	5.8133	23.9087	6.1363	30.0450	55.0906	55.0906	-561.3044
12	26.5844	0.2006	5.5226	22.7133	5.8295	28.5428	52.3361	52.3361	-533.2390
13	35.0239	0.2643	5.2319	21.5179	5.5227	27.0405	49.5816	49.5816	-505.1737
14	43.4634	0.3280	5.2901	21.7570	5.5840	27.3410	50.1325	50.1325	-510.7869
15	51.9029	0.3917	5.4063	22.2351	5.7068	27.9419	51.2343	51.2343	-522.0129
16	60.3424	0.4554	5.1157	21.0397	5.3999	26.4396	48.4797	48.4797	-493.9477
17	66.2500	0.5000	0.0000	0.0000	0.0000	0.0000	0.0000	0.0000	0.0000

(g) Tabulated data, $\epsilon_1 = -3.4^\circ$, $\epsilon_2 = -3.0^\circ$, $z/w = 0.100$.

DVOR = LVOR = 0.0

I	YFS	YH	QFS	DV	DI	DT	LI	LT	M
1	-66.2500	-0.5000	0.0000	0.0000	0.0000	0.0000	0.0000	0.0000	0.0000
2	-65.5875	-0.4950	4.0111	16.4970	4.2340	20.7311	38.0125	38.0125	-387.3000
3	-64.2625	-0.4850	5.0285	20.6811	5.3079	25.9890	47.6534	47.6534	-485.5283
4	-52.7350	-0.3980	4.8250	19.8443	5.0931	24.9374	45.7252	45.7252	-465.8826
5	-24.1150	-0.1820	6.5980	27.1364	6.9647	34.1011	62.5279	62.5279	-637.0804
6	-19.8750	-0.1500	6.5980	27.1364	6.9647	34.1011	62.5279	62.5279	-637.0804
7	10.6000	0.0800	4.8831	20.0833	5.1545	25.2378	46.2761	46.2761	-471.4957
8	29.8125	0.2250	5.2319	21.5179	5.5227	27.0405	49.5816	49.5816	-505.1739
9	45.1825	0.3410	6.1039	25.1042	6.4431	31.5473	57.8452	57.8452	-589.3696
10	60.2875	0.4550	6.3074	25.9410	6.6579	32.5989	59.7733	59.7733	-609.0152
11	64.3950	0.4860	5.2319	21.5179	5.5227	27.0405	49.5816	49.5816	-505.1739
12	65.4550	0.4940	4.3599	17.9316	4.6022	22.5338	41.3180	41.3180	-420.9782
13	66.2500	0.5000	0.0000	0.0000	0.0000	0.0000	0.0000	0.0000	0.0000

(h) Tabulated data, $\epsilon_1 = -3.4^\circ$, $\epsilon_2 = -3.0^\circ$, $z/w = 0.414$.

Figure 49.- Concluded.

AERODYNAMIC DESIGN AND OPERATING TIME AVERAGED LOADS
VANE SET 7

Global Load	80 by 120 mode	40 by 80 mode
Onset angle, deg	0	0
Outflow angle, deg	40	40
Lift, lb	-265,000	-13,600
Drag, lb	282,000	17,800
Pitching moment about vane hinge line, ft/lb	-2,300,000	-130,000
Wall pressure differential, lb/ft ²	-12.0	-18.0

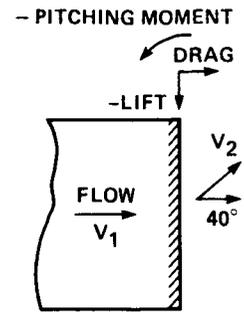

EXCEPTION:
VANE LOADS
PERPENDICULAR
TO DEFLECTED
VANE SURFACE

Local load	80 by 120 mode	40 by 80 mode
Onset angle, deg	0	0
Outflow angle, deg (vane)	45	45
(bird screen)	40	40
Vane lift perpendicular to vane surface, lb/ft of vane span	-170 (total span) 2274 ft	-103 (total span) 214 ft
Vane drag parallel to vane surface, lb/ft of vane span	0	0
Vane pitching moment about vane hinge line, ft/lb of vane span	-1003	-626
Force perpendicular to structure surface exposed to exit flow, lb/ft of structure span		
9 in. depth horizontally	17 (total span) 1892 ft	10 (total span) 179 ft
12 in. depth horizontally	22 (total span) 189 ft	14 (total span) 18 ft
Vertical column	22 (total span) 1030 ft	0
Bird screen		
Lift, lb/ft ² of frontal area	1.9 (total area) 20,702 ft ²	1.2 (total area) 2145 ft ²
Drag, lb/ft ² of frontal area	4.5	2.8

Note: Loads acting at 0.44 of vane chord from leading edge except fixed structural and bird screen loads.

Figure 50.- Global design and local loads for vane set 7.

AERODYNAMIC DESIGN TIME AVERAGED LOADS
VANE SET 8

Global load (total vane span - 21067.0 ft)

Onset angle	deg	3.0	-3.0
Outflow angle	deg	-4.8	-6.8
Lift	lb	255400.	241700.
Drag	lb	32700.	69000.
Pitching moment about vane 1/4 chord	ft-lb	-222400.	-269000.

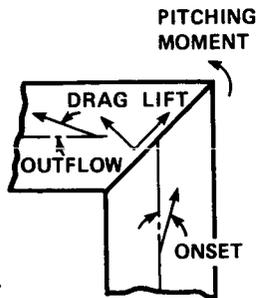

Note:

1. Loads acting at 1/4 vane chord.
2. Lift acting along vane set. Positive direction toward outside wall.
3. Drag perpendicular to vane set.
4. See figures for vane spanwise loads.

(a) Maximum global design load.

Figure 51.- Global design and operating loads for vane set 8: 40 x 80 mode.

AERODYNAMIC OPERATING TIME AVERAGED LOADS
VANE SETS 8, CONTINUED

Global load (total vane span = 21067.0 ft)

Onset angle	deg	0.0
Outflow angle	deg	-3.8
Lift	lb	238500.
Drag	lb	40900.
Pitching moment	ft-lb	-248200.
about 1/4 vane chord		

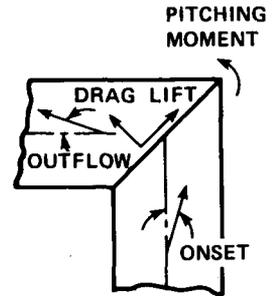

Note:

1. Loads acting at 1/4 vane chord.
2. Lift acting along vane set. Positive direction toward outside wall.
3. Drag perpendicular to vane set.
4. See figures for vane spanwise loads.

(b) Global operating load.

Figure 51.- Continued.

CONSTANT INPUTS		KNOTS	SPLITTER PLATE CD	
TUNNEL SPEED	300.00	FAHREN.	TOTAL SPLITTER PLATE	0.025
TEMP. AROUND TUNL CIRCUIT	70.0	PSF	AREA (PLANFORM)	7920.0
TEST SECTION Q	262.44	SLUG/FT3	NO. OF SPLITTER PLATES	11.0
MASS DENSITY AT VANE	0.002347			
DP/QL ROUGHNESS	0.04			
VANE SET FRONTAL AREA	32323.0			
INDIVID. VANE SPAN	132.5			
NO. OF VANES	159.0			
PITCH OF VANE SET	1.5			
VANE CHORD	3.0			
TOTAL VANE SPAN	21067.0			
CALCULATION				
ONSET ANGLE	3.0	DEG	-3.0	-3.0
OUTFLOW ANGLE	-0.8	DEG	-2.8	-6.8
BETA 1	48.0	DEG	42.0	42.0
BETA 2	-45.8	DEG	-47.8	-51.8
Q AT 0 DEG ONSET	3.3	PSF	3.3	3.3
VZ	37.6	FT/SEC	37.6	37.6
Q AT ONSET ANGLE	3.7	PSF	3.0	3.0
DP/QL VISCOUS DRAG COEFF	0.124		0.176	0.176
CM ABOUT 1/4 CHORD	-305		-455	-455
K1 (V/VAVG)2*A	1.036		1.036	1.036
QMAX/QAVG	1.000		1.000	1.000
MOMENTUM LIFT	238143.8	LB	223037.0	241733.6
OTHER LIFT	0.0	LB	0.0	0.0
TOTAL LIFT	238143.8	LB	223037.0	241733.6
INVISCID DRAG	-9798.4	LB	22576.0	44765.3
VISCOUS DRAG	15417.4	LB	17741.0	17741.0
INVISCID+VISCOUS DRAG	5619.0	LB	40317.0	62506.3
ROUGHNESS DRAG	4973.4	LB	4032.0	4032.0
SPLITTER PLATE DRAG	3046.5	LB	2469.9	2469.9
OTHER DRAG	0.0	LB	0.0	0.0
TOTAL DRAG	13638.9	LB	46818.9	69009.2
PITCHING MOMENT C/4	-222445.3	FTLB	-269035.6	-269035.6

(c) Tabulated global design load for load cases considered.

Figure 51.- Concluded.

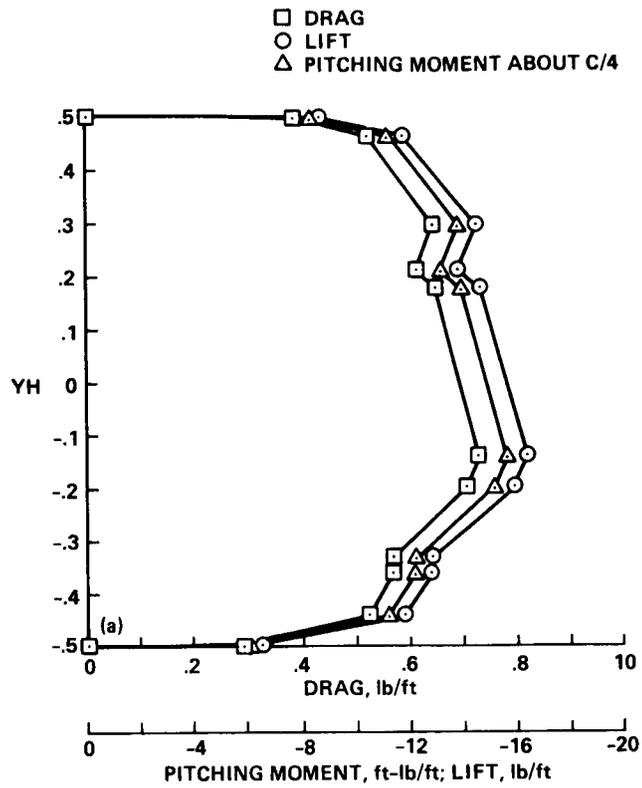

(a) $\epsilon_1 = 3.0^\circ$, $\epsilon_2 = -0.8^\circ$.

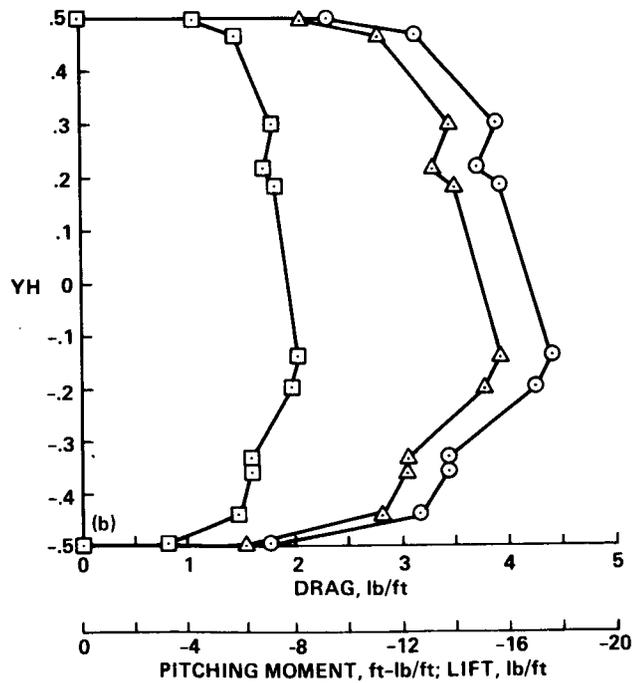

(b) $\epsilon_1 = 3.0^\circ$, $\epsilon_2 = -4.8^\circ$.

Figure 52.- Variation of local design load with vane span for vane set 8;
40 x 80 mode.

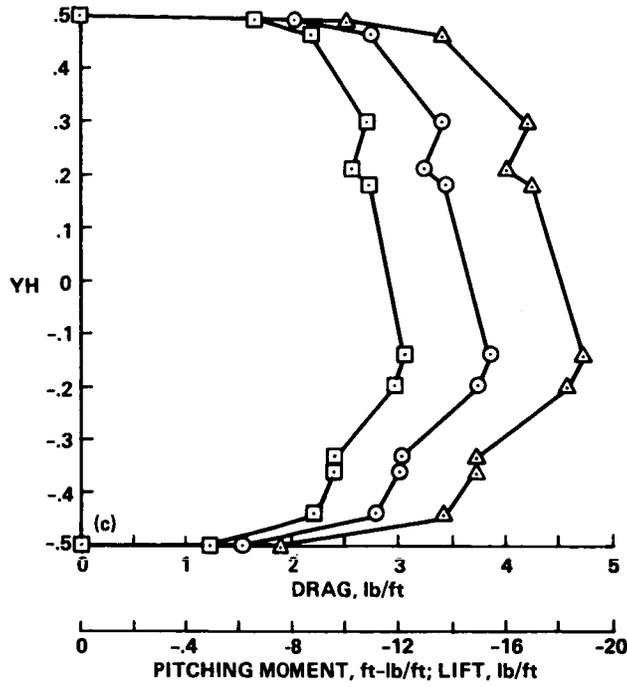

(c) $\epsilon_1 = 3.0^\circ$, $\epsilon_2 = -2.8^\circ$.

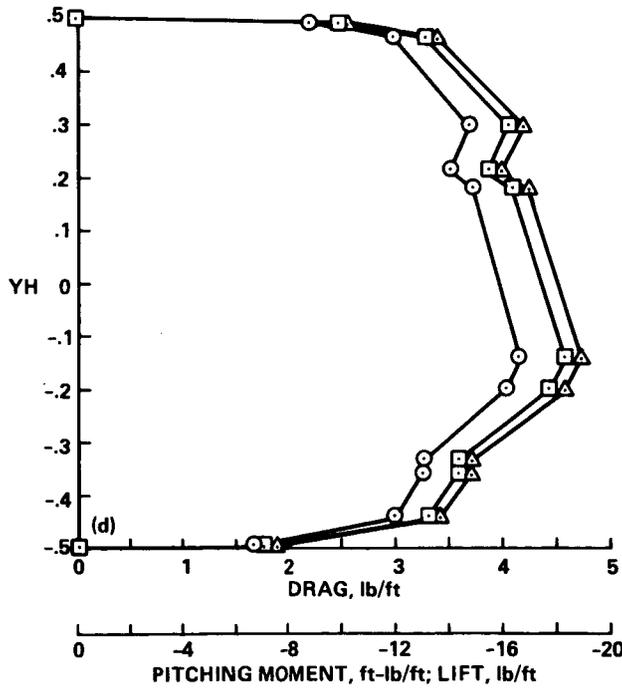

(d) $\epsilon_1 = -3.0^\circ$, $\epsilon_2 = -6.8^\circ$.

Figure 52.- Concluded.

DDT = DTRUSS = LTRUSS = LLT = MTRUSS = 0.0

I	YFS	YH	QFS	DV	DI	DT	LI	LT	MM	MT
1	-66.2500	-0.5000	0.0000	0.0000	0.0000	0.0000	0.0000	0.0000	0.0000	0.0000
2	-65.5875	-0.4950	2.2795	0.5607	-0.2695	0.2913	6.5490	6.5490	-6.2571	-6.2571
3	-58.4325	-0.4410	4.0959	1.0076	-0.4842	0.5234	11.7677	11.7677	-11.2433	-11.2433
4	-47.5675	-0.3590	4.4521	1.0952	-0.5263	0.5689	12.7910	12.7910	-12.2210	-12.2210
5	-43.9900	-0.3320	4.4521	1.0952	-0.5263	0.5689	12.7910	12.7910	-12.2210	-12.2210
6	-26.1025	-0.1970	5.5206	1.3581	-0.6526	0.7055	15.8608	15.8608	-15.1540	-15.1540
7	-18.6825	-0.1410	5.6987	1.4019	-0.6736	0.7282	16.3725	16.3725	-15.6428	-15.6428
8	23.8500	0.1800	5.0932	1.2529	-0.6021	0.6509	14.6329	14.6329	-13.9800	-13.9800
9	28.2225	0.2130	4.8082	1.1828	-0.5684	0.6144	13.8143	13.8143	-13.1986	-13.1986
10	39.3525	0.2970	5.0576	1.2442	-0.5979	0.6463	14.5306	14.5306	-13.8830	-13.8830
11	61.6125	0.4650	4.0959	1.0076	-0.4842	0.5234	11.7677	11.7677	-11.2433	-11.2433
12	65.5875	0.4950	3.0274	0.7447	-0.3579	0.3869	8.6979	8.6979	-8.3103	-8.3103
13	66.2500	0.5000	0.0000	0.0000	0.0000	0.0000	0.0000	0.0000	0.0000	0.0000

(a) $\epsilon_1 = 3.0^\circ$, $\epsilon_2 = -0.8^\circ$.

DDT = DTRUSS = LTRUSS = LLT = MTRUSS = 0.0

I	YFS	YH	QFS	DV	DI	DT	LI	LT	MM	MT
1	-66.2500	-0.5000	0.0000	0.0000	0.0000	0.0000	0.0000	0.0000	0.0000	0.0000
2	-65.5875	-0.4950	2.2795	0.5607	0.2554	0.8162	7.0236	7.0236	-6.2571	-6.2571
3	-58.4325	-0.4410	4.0959	1.0076	0.4589	1.4665	12.6206	12.6206	-11.2433	-11.2433
4	-47.5675	-0.3590	4.4521	1.0952	0.4988	1.5941	13.7180	13.7180	-12.2210	-12.2210
5	-43.9900	-0.3320	4.4521	1.0952	0.4988	1.5941	13.7180	13.7180	-12.2210	-12.2210
6	-26.1025	-0.1970	5.5206	1.3581	0.6186	1.9766	17.0103	17.0103	-15.1540	-15.1540
7	-18.6825	-0.1410	5.6987	1.4019	0.6385	2.0404	17.5590	17.5590	-15.6428	-15.6428
8	23.8500	0.1800	5.0932	1.2529	0.5707	1.8236	15.6934	15.6934	-13.9800	-13.9800
9	28.2225	0.2130	4.8082	1.1828	0.5387	1.7216	14.8154	14.8154	-13.1986	-13.1986
10	39.3525	0.2970	5.0576	1.2442	0.5667	1.8108	15.5836	15.5836	-13.8830	-13.8830
11	61.6125	0.4650	4.0959	1.0076	0.4589	1.4665	12.6206	12.6206	-11.2433	-11.2433
12	65.5875	0.4950	3.0274	0.7447	0.3392	1.0840	9.3282	9.3282	-8.3103	-8.3103
13	66.2500	0.5000	0.0000	0.0000	0.0000	0.0000	0.0000	0.0000	0.0000	0.0000

(b) $\epsilon = 3.0^\circ$, $\epsilon_2 = -4.8^\circ$.

Figure 53.- Tabulated local design loads with vane span for vane set 8;
40 x 80 mode.

DDT = DTRUSS = LTRUSS = LLT = MTRUSS = 0.0

I	YFS	YH	QFS	DV	DI	DT	LI	LT	MM	MT
1	-66.2500	-0.5000	0.0000	0.0000	0.0000	0.0000	0.0000	0.0000	0.0000	0.0000
2	-65.5875	-0.4950	1.8480	0.5988	0.6208	1.2196	6.1335	6.1335	-7.5677	-7.5677
3	-58.4325	-0.4410	3.3207	1.0759	1.1156	2.1915	11.0212	11.0212	-13.5981	-13.5981
4	-47.5675	-0.3590	3.6094	1.1695	1.2126	2.3820	11.9796	11.9796	-14.7806	-14.7806
5	-43.9900	-0.3320	3.6094	1.1695	1.2126	2.3820	11.9796	11.9796	-14.7806	-14.7806
6	-26.1025	-0.1970	4.4757	1.4501	1.5036	2.9537	14.8547	14.8547	-18.3279	-18.3279
7	-18.6825	-0.1410	4.6201	1.4969	1.5521	3.0490	15.3339	15.3339	-18.9192	-18.9192
8	23.8500	0.1800	4.1292	1.3379	1.3872	2.7251	13.7046	13.7046	-16.9090	-16.9090
9	28.2225	0.2130	3.8982	1.2630	1.3096	2.5726	12.9379	12.9379	-15.9630	-15.9630
10	39.3525	0.2970	4.1003	1.3285	1.3775	2.7060	13.6088	13.6088	-16.7908	-16.7908
11	61.6125	0.4650	3.3207	1.0759	1.1156	2.1915	11.0212	11.0212	-13.5981	-13.5981
12	65.5875	0.4950	2.4544	0.7952	0.8246	1.6198	8.1461	8.1461	-10.0508	-10.0508
13	66.2500	0.5000	0.0000	0.0000	0.0000	0.0000	0.0000	0.0000	0.0000	0.0000

(c) $\epsilon_1 = -3.0^\circ$, $\epsilon_2 = -2.8^\circ$.

DDT = DTRUSS = LTRUSS = LLT = MTRUSS = 0.0

I	YFS	YH	QFS	DV	DI	DT	LI	LT	MM	MT
1	-66.2500	-0.5000	0.0000	0.0000	0.0000	0.0000	0.0000	0.0000	0.0000	0.0000
2	-65.5875	-0.4950	1.8480	0.5988	1.2311	1.8298	6.6477	6.6477	-7.5677	-7.5677
3	-58.4325	-0.4410	3.3207	1.0759	2.2120	3.2879	11.9451	11.9451	-13.5981	-13.5981
4	-47.5675	-0.3590	3.6094	1.1695	2.4044	3.5739	12.9838	12.9838	-14.7806	-14.7806
5	-43.9900	-0.3320	3.6094	1.1695	2.4044	3.5739	12.9838	12.9838	-14.7806	-14.7806
6	-26.1025	-0.1970	4.4757	1.4501	2.9815	4.4316	16.0999	16.0999	-18.3279	-18.3279
7	-18.6825	-0.1410	4.6201	1.4969	3.0776	4.5745	16.6193	16.6193	-18.9192	-18.9192
8	23.8500	0.1800	4.1292	1.3379	2.7506	4.0885	14.8535	14.8535	-16.9090	-16.9090
9	28.2225	0.2130	3.8982	1.2630	2.5967	3.8598	14.0225	14.0225	-15.9630	-15.9630
10	39.3525	0.2970	4.1003	1.3285	2.7314	4.0599	14.7496	14.7496	-16.7908	-16.7908
11	61.6125	0.4650	3.3207	1.0759	2.2120	3.2879	11.9451	11.9451	-13.5981	-13.5981
12	65.5875	0.4950	2.4544	0.7952	1.6350	2.4302	8.8290	8.8290	-10.0508	-10.0508
13	66.2500	0.5000	0.0000	0.0000	0.0000	0.0000	0.0000	0.0000	0.0000	0.0000

(d) $\epsilon_1 = -3.0^\circ$, $\epsilon_2 = -6.8^\circ$.

Figure 53.- Concluded.



Report Documentation Page

1. Report No. NASA TM 89413	2. Government Accession No.	3. Recipient's Catalog No.
4. Title and Subtitle Time-Averaged Aerodynamic Loads on the Vane Sets of the 40- by 80-Foot and 80- by 120-Foot Wind Tunnel Complex		5. Report Date August 1987
7. Author(s) Kiyoshi Aoyagi, Lawrence E. Olson, Randall L. Peterson, Gloria K. Yamauchi, James C. Ross, and Thomas R. Norman		6. Performing Organization Code
9. Performing Organization Name and Address Ames Research Center Moffett Field, CA 94035		8. Performing Organization Report No. A-87039
12. Sponsoring Agency Name and Address National Aeronautics and Space Administration Washington, DC 20546-0001		10. Work Unit No. 505-61-71
15. Supplementary Notes Point of Contact: Lawrence E. Olsen, Ames Research Center, M/S 247-2, Moffett Field, CA 94035, (415) 694-6681 or FTS 464-6681		11. Contract or Grant No.
16. Abstract Time-averaged aerodynamic loads are estimated for each of the vane sets in the National Full-Scale Aerodynamic Complex (NFAC). The methods used to compute global and local loads are presented. Experimental inputs used to calculate these loads are based primarily on data obtained from tests in the 1/10-Scale Vane-Set Test Facility and from tests conducted in the NFAC 1/50-Scale Facility. For those vane sets located directly downstream of either the 40- by 80-ft test section or the 80- by 120-ft test section, aerodynamic loads caused by the impingement of model-generated wake vortices and model-generated jet and propeller wakes are also estimated.		13. Type of Report and Period Covered Technical Memorandum
17. Key Words (Suggested by Author(s)) Vane set aerodynamic loads National Full-Scale Aerodynamic Complex 40- by 80-Foot Wind Tunnel Complex 80- by 120-Foot Wind Tunnel Complex		14. Sponsoring Agency Code
19. Security Classif. (of this report) Unclassified		18. Distribution Statement Unclassified - Unlimited Subject Category - 09
20. Security Classif. (of this page) Unclassified	21. No. of pages 190	22. Price A09