

DEPARTMENT OF MECHANICAL ENGINEERING AND MECHANICS
SCHOOL OF ENGINEERING
OLD DOMINION UNIVERSITY
NORFOLK, VIRGINIA

EXPERIMENTAL AND ANALYTICAL STUDIES
IN FLUIDS

By

Gene L. Goglia, Principal Investigator

and

Adel Ibrahim

Final Report
For the period ending August 31, 1984

Prepared for the
National Aeronautics and Space Administration
Langley Research Center
Hampton, Virginia 23665

Under
NASA Grant NSG-1177
Richard F. Hellbaum, Technical Monitor
FCSD-Cockpit Systems Branch

Submitted by the
Old Dominion University Research Foundation
P.O. Box 6369
Norfolk, Virginia 23508

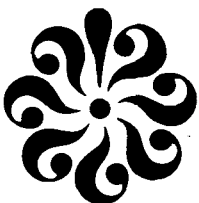

September 1984

TABLE OF CONTENTS

	<u>Page</u>
INTRODUCTION.....	1
EXPERIMENTAL EQUIPMENT.....	7
EXPERIMENTAL RESULTS.....	8
REGRESSION ANALYSIS.....	11
CONCLUSION.....	41
REFERENCES.....	42
APPENDIX.....	92

LIST OF TABLES

<u>Table</u>	<u>Page</u>
1 Vortex tube dimensions.....	43

LIST OF FIGURES

<u>Figure</u>	<u>Page</u>
1 Flow rate vs. frequency response for sensor 1 with three swirlers having various diameters.....	44
2 Flow rate vs. frequency for sensor 1 with two swirlers having various diameters.....	45
3 Flow rate vs. frequency for sensor 2 with three swirlers having various diameters.....	46
4 Flow rate vs. frequency for sensor 2 with two swirlers having various diameters.....	47
5 Flow rate vs. frequency for sensor 3 with three swirlers having various diameters.....	48
6 Flow rate vs. frequency for sensor 3 with two swirlers having various diameters.....	49
7 Flow rate vs. frequency for sensor 4 with three swirlers having various diameter.....	50
8 Flow rate vs. frequency for sensor 4 with two swirlers having various diameters.....	51

TABLE OF CONTENTS - continued

LIST OF FIGURES - continued

<u>Figure</u>		<u>Page</u>
9	Flow rate vs. frequency for sensor 5 with three swirlers having various diameters.....	52
10	Flow rate vs. frequency for sensor 5 with two swirlers having various diameters.....	53
11	Flow rate vs. frequency for sensor 6 with three swirlers having various diameters.....	54
12	Flow rate vs. frequency for sensor 6 with two swirlers having various diameters.....	55
13	Flow rate vs. frequency for sensor 7 with three swirlers having various dimeters.....	56
14	Flow rate vs. frequency for sensor 7 with two swirlers having various diameters.....	57
15	Flow rate vs. frequency for sensor 8 with three swirlers having various diameters.....	58
16	Flow rate vs. frequency for sensor 8 with two swirlers having various diameters.....	59
17	Flow rate vs. frequency for sensor 9 with three swirlers having various diameters.....	60
18	Flow rate vs. frequency for sensor 9 with two swirlers having various diameters.....	61
19	Flow rate vs. frequency for sensor 10 with three swirlers having various diameters.....	62
20	Flow rate vs. frequency for sensor 10 with two swirlers having various diameters.....	63
21	Flow rate vs. frequency for sensor 11 with three swirlers having various diameters.....	64
22	Flow rate vs. frequency for sensor 11 with two swirlers having various diameters.....	65
23	Flow rate vs. frequency for sensor 12 with three swirlers having various diameters.....	66
24	Flow rate vs. frequency for sensor 12 with two swirlers having various diameters.....	67

TABLE OF CONTENTS - continued

LIST OF FIGURES - continued

<u>Figure</u>	<u>Page</u>
25 Effect of various swirler diameters on the frequency, sensor 1.....	68
26 Effect of various swirler diameters on the frequency, sensor 2.....	69
27 Effect of various swirler diameters on the frequency, sensor 3.....	70
28 Effect of various swirler diameters on the frequency, sensor 4.....	71
29 Effect of various swirler diameters on the frequency, sensor 5.....	72
30 Effect of various swirler diameters on the frequency, sensor 4.....	73
31 Effect of various swirler diameters on the frequency, sensor 7.....	74
32 Effect of various swirler diameters on the frequency, sensor 8.....	75
33 Effect of various swirler diameters on the frequency, sensor 9.....	76
34 Effect of various swirler diameters on the frequency, sensor 10.....	77
35 Effect of various swirler diameters on the frequency, sensor 11.....	78
36 Effect of various swirler diameters on the frequency, sensor 12.....	79
37 Effect of the sensor tube length on the frequency.....	80
38 Effect of sensor tube diameter on the frequency.....	81
39 Effect of the nozzle length on the frequency.....	82
40 Effect of the (P) length on the frequency.....	83
41 Effect of pick up signal point on frequency.....	84
42 Effect of the swirler diameter on frequency.....	85

TABLE OF CONTENTS - contents

LIST OF FIGURES - continued

<u>Figure</u>		<u>Page</u>
43	Effect of sensor tube length increase on frequency.....	86
44	Effect of increase of sensor tube diameter on frequency.....	87
45	Effect of increase of length (P) on the frequency.....	88
46	Effect of increase of nozzle length on frequency.....	89
47	Effect of increase of the pickup signal point length on frequency.....	90
48	Effect of increase of the swirler diameter on frequency.....	91

EXPERIMENTAL AND ANALYTICAL STUDIES IN FLUIDS

By

Gene L. Goglia¹ and Adel Ibrahim²

INTRODUCTION

At the present time, there are two types of airspeed instruments which might be used on aircraft: the differential-pressure type and the true airspeed meter. The pitot-static instrument, which is of the differential-pressure type, is however exclusively used. This indicator is calibrated in terms of airspeed at a standard air density. In order to obtain the actual airspeed at other densities, a correction must be made. Further, the performance of the pitot-static tube is affected by installation location. One must, therefore, find a location for the pitot-static openings that will be free from structural interference effects.

The true airspeed sensor is the conventional type of meter with rotating surfaces, such as propellers, which gives readings independent of air density. The sensor is usually used in making measurements of airspeeds in the lower ranges. One kind of true airspeed sensor used by the United States Navy on airships is known as the commutator-condensor type.

The idea of designing a true airspeed sensor originated from the discovery of a vortex whistle and the flow phenomenon-precession, which is different from that of vortex shedding. The understanding of the origin of

¹Eminent Professor, Mechanical Engineering and Mechanics Department, Old Dominion University, Norfolk, Virginia 23508

²Graduate Research Assistant, Mechanical Engineering and Mechanics Department, Old Dominion University, Norfolk, Virginia 23508.

the sound or whistle was studied by a few investigators [1-3]* from different points of view. Also, the vortex shedding problems associated with the aerolian tones and edgetones were studied and observed experimentally by many researchers. The project was maintained by a small staff which worked on the vortex whistle and precessional flow problems. Bernard Vonnegut [1] in 1954 was the first to discover and investigate the vortex whistle. In his laboratory, he was conducting an experiment on a vortex creating housing for aircraft thermometers. During the experiment, he observed a sound that was generated when the rotating air escaped from the open end of the tube. He also found that the frequency of this sound increased with increasing rates of air flow. In addition, the frequency that was produced decreased as the length of the tube in which the vortex rotates was increased. Vonnegut suggested that the vortex instability leaving the tube caused the whistle, and he developed an empirical formula describing this performance.

In 1955, Irving Michelson [2] published a paper which was the first analytical work on the theory of a vortex whistle. He considered the flow throughout the whistle to be two-dimensional unsteady, inviscid and isentropic. He was able to arrive at linearized simultaneous equations. A secular equation was then derived with one root of particular interest being noted. From the solution and the secular equation, he noted the occurrence of a frequency that was proportional to the flow speed U . When he introduced the isentropic flow relationship, he was able to express the frequency in terms of pressure drop and reservoir sound speed. Michelson's theory compares favorably with Vonnegut's empirical formula.

In 1957, J. P. Nicklas [3] on his investigation of a vortex tube acoustic true airspeed sensor conducted at the Cornell Aeronautical Laboratory.

*Numbers in brackets indicate references.

He investigated the feasibility of measuring true aircraft airspeed by measuring the frequency of the sound produced in a vortex tube mounted on an airplane. Nicklas, however, concentrated his efforts on the single tangential nozzle vortex tube. His data revealed that the fundamental sound frequency of a vortex tube could be considered a linear function of true airspeed in the subsonic speed range. He indicated that the altitude and temperature sensitivities of the vortex tube could be reduced by proper design. In his conclusion, he also mentioned that no significant improvement in signal quality was obtained by modifying the tube shape. Nicklas studied the effect the angle of attack had on frequency response.

In 1960, M. Suzuki studied and investigated the vortex tube with the objective of finding a method of eliminating the whistle occurring in the vortex tube. In his analysis, he assumed both a free and forced vortex region of velocity distribution. Suzuki, using the boundary conditions at the wall and at the interface between free and forced vortex, derived a linearly proportional relationship between the peculiar frequency and the angular velocity of the forced vortex. In his derivation, the density and velocity components were separated into mean and fluctuation terms. Suzuki introduced a number of assumptions and restrictions to enable him to obtain the Bessel's equation and its solution. Although Suzuki did not present either numerical or quantitative results, he did, however, report and discuss his experimental data. In addition to the linear relationship, Suzuki found that no sound was produced at small flow rates, and that when the value of L_c/D_c was less than unity, no distinct frequency could be observed. L_c was the length of cold tube in his model, whereas the D_c was the diameter of the outlet.

In 1963, Robert C. Chanaud [4] converted Vonnegut's data into Reynolds

and Strouhal numbers, and found that the air and water data were almost coincident, suggesting that dynamic similarity might occur. The perturbation of a two-dimensional inviscid vortex flow was investigated. Chanaud derived a linear relationship between perturbation frequency and fluid angular velocity for neutrally stable oscillations of an inviscid flow. His results support the investigations and conclusions reported by Vonnegut and Michelson. He confirmed that the precessional frequency is the same as the sound frequency and that the fluid angular velocity is simply related with the precession frequency of the unstable motion. In his conclusion, he mentioned that "high speed" was not necessary to generate the whistle, as velocities of five feet per second were found sufficient. He, as others did, explained that the instability which occurred was due to the sudden area change at the tube exit. Chanaud's results show that the amplitude of oscillation within the tube depends on how the area changes; a gradual area increase permits larger amplitude flow oscillations whereas an abrupt area change reduces the magnitude of the flow oscillation within the tube. He mentioned that this may be the reason Vonnegut did not detect the sound with a flared tube. He also stated that no quantitative information on the nature of the instability had been obtained.

Powell [5] in 1964 published a paper discussing the origin of the sound. He showed and explained in detail from a physical point of view how aerodynamic sound in an unsteady fluid flow was generated as a result of the movement of vortices, or of vorticity.

In 1965, Chanaud [8] published a paper describing the experimental study in certain swirling flows. One of the swirling flows was studied by Talbot. The experimental results show that the periodic motion in both a vortex whistle and a cyclone separator can be described in terms of a

hydrodynamic oscillator where the frequency is closely related to the angular velocity of the flow. Chanaud also mentioned that the two important parameters, the Reynolds number and the Strouhal number, are both of such magnitude that it appears no important simplifications can be made in the equations of motion to solve the problem analytically. The energy of the oscillator is derived from the hydrodynamic instability of the fluid within a reversed-flow region on the swirl axis. No quantitative information is available on the condition of a steady reversed-flow region. Chanaud, however, mentioned that the experimental results suggest that the two-dimensional perturbation analysis may prove of some value in describing the amplifier part of the oscillator.

Rodely, found that the oscillative motion began only beyond certain Reynolds numbers. He also observed that the oscillative motion was accompanied by the reversal of flow near the tube axis. Gove and Ranz [6] in their paper explained in detail this reversal of flow. The reversal of flow was caused by the sudden area enlargement at the tube exit. In the better swirler designs the Rossby number could be held constant for various Reynolds numbers. This indicates that the frequency is linearly related to the flow rate. However, below some Reynolds number, due to viscous effects, there were deviations from the constant value.

Chanaud again in 1970 [8] suggested that in the aerodynamic whistle the vibrating system is the air itself. This is in contrast to nonaerodynamic devices such as a drum or loud speaker, where sound is generated when a mechanical system vibrates and disturbs the air. Chanaud showed that due to the instability of the system a small disturbance in the stream flowing through the aerodynamic whistle was amplified, and that kinetic energy was converted to oscillatory energy. Part of the energy of the amplified

disturbance is fed back upstream, where the flow is most unstable, and, if the right frequency and amplitude exists, it interacts with the original disturbance to maintain the process. After a few cycles the feedback controls the input completely. A whistle is produced when the flow speed is high enough and the frequency is in the audible range.

As previously mentioned, there is one common feature that introduces the concept of "no moving parts" in fluidic devices. In contrast to this concept is the device with moving parts. Fluidic devices have been widely researched in the past 19 years. Simplicity, reliability and easy maintenance make fluidic devices attractive. A quote from the text Design Theory of Fluidic Components, worthy of mention is:

Although present theory gives results sufficiently accurate for engineering design, it is not possible to justify all the assumptions used. Thus in a scientific sense the theory is not always satisfying, but in an engineering design sense the theory does seem to be satisfactory.

In this investigation fluidic models were designed and then tested in both water and air. Flow visualization tests in a water model were undertaken in order to actually see the flow phenomenon of precession. Smaller models were subsequently made for testing with compressed air and in a wind tunnel. An experimental analysis was provided in this study. The physical models were simulated and used in computer calculation. The numerical solutions involved true airspeeds up to 321.89 km (200 miles) per hour. Six different combinations of vortex tubes and swirlers were used both in computer calculations as well as in experimental tests.

The objective of this study was two-fold. The first objective was to analyze and design a true airspeed sensor which will replace the convention-

al pitot-static pressure transducer for small commercial aircraft. The desired features of this sensor should include the flow phenomenon-precision, vortex whistle and have no moving parts. In addition, this sensor should not be affected by temperature, density, altitude, and humidity changes. The second objective was to obtain a numerical solution and predict the frequency response which is generated by the vortex whistle at a certain airspeed. In a previous study, Shen [15], theoretical results were presented quantitatively to enable a comparison with experimental data. That study also presented a general solution to the problem and provided specific analytical results for comparison purposes. A correction factor for viscous effects was also introduced to enable a correlation between theoretical results and experimental data.

The objective of the current investigation was to continue previous studies with the intent to develop a new technique of sensing. The new technique would then be used to develop a true airspeed sensor.

EXPERIMENTAL EQUIPMENT

The equipment used throughout these experiments essentially consisted of an air supply, pressure regulators, a calibrated orifice plate flow meter, a pressure transducer, an electronic condenser microphone and signal conditioner, an oscilloscope, a frequency counter and a vortex tube sensor.

The air used for the experiments flowed from a stagnation tank and ultimately passed through the sensor. A calibrated orifice plate flow meter with a capacity of one cubic foot per minute was used to measure the flow rate. The differential pressure across the orifice plate was measured with a pressure cap entrance pressure transducer. An electronic condenser microphone and signal conditioner was used to detect the whistle signals. The

electronic signal from the microphone was directed to an amplifier which had a gain of 50. The amplifier signal was forwarded to a comparator circuit whose output was connected to an oscilloscope and frequency counter.

In previous investigations frequency measurements below 700 HZ were not attainable. In the current investigation, however, signals through the 60 HZ noise level down to 20 HZ were achieved. This was accomplished through use of a particular combination of amplifier and comparator circuit.

The true air speed sensor that was used in this study consisted of four blocks. The air flow was directed through an inlet cover block to a swirler block. Within the swirler block the vortex swirl was generated. The air then flowed through a third block which housed the vortex tube, which in reality was a diverging nozzle. Within the swirler block was placed a small orifice and microphone. The generated signal frequency which occurred at the sudden enlargement was the location at which the whistle was detected. In the side of the vortex tube by housing a small orifice and microphone the whistle noise could be observed. From the sudden enlargement the air then flowed to the cover block. Noise on its way to the microphone was reduced by installing a pad of felt in the blocks.

EXPERIMENTAL RESULTS

The experimental data obtained from this investigation was arrived at through the use of twelve (12) vortex tubes with diameters ranging from 0.25 inches to 0.093 inches and five (5) swirlers with diameters from 0.5 inches to 2.0 inches. Experimental results were obtained for each vortex tube run separately with each of the swirlers or sixty (60) different configurations.

. A primary objective in conducting these experiments was to determine

the effect that the sensor geometric parameters had upon the frequency precession.

A statistical technique, namely the regression analysis, was used to determine frequency dependency upon sensor geometry. This analysis involved each of the five (5) swirlers combined with each of the twelve (12) vortex tubes.

Figures 1 through 24 are flow ratio versus frequency graphs for the various combinations of vortex tubes and swirlers. It is readily observable that the flow rate is linearly proportional to the frequency.

Figures 25 through 35 were plotted to indicate the effect changes in swirler diameter had on the frequency. It is apparent from those plots that frequency decreases as the swirler diameter is increased for the majority of the vortex tubes.

Figure 36 reveals that tube length is linearly proportional to frequency response and also that frequency decreases with increase in tube length. Similarly, Figure 37 shows frequency to be linearly proportional to the vortex tube diameter and frequency increase with a decrease in vortex tube diameter.

Figure 38 reveals the exit nozzle length is linearly proportional to frequency and that the frequency increases with an increase in nozzle length.

Figures 39 and 40 show both P and P-S to be linearly proportional to frequency response.

Figure 42 enables one to estimate the percentages decrease in frequency corresponding to a vortex tube length increase. Similarly figure 43 enables one to estimate the percentage decrease in frequency corresponding to a vortex tube diameter increase.

Figure 44 enables one to estimate the percentage change in frequency due to a change in the P parameter. Figure 45 enables one to estimate the percentage change in frequency due to a change in the S parameter. Figure 46 enables one to estimate the percentage change in frequency due to a change in the P-S parameter. Figure 47 enables one to estimate the change in frequency due to a change in swirler diameter.

Although in previous investigations frequencies below 700 HZ were not attainable, however, through modifications made to the sensor, frequencies as low as 20 HZ are attainable. Specifically by using vortex tube number four and either swirler two or three a minimum frequency precession of 20 HZ is attainable.

REGRESSION ANALYSIS

NASA --- LANGLEY RESEARCH CENTER
HAMPTON, VIRGINIA
MAINTAINED BY COMPUTER SCIENCES CORPORATION

S P S 8 --- STATISTICAL PACKAGE FOR THE SOCIAL SCIENCES

VERSION 0.3 -- MAY 04, 1982

160000 CM MAXIMUM FIELD LENGTH REQUEST

FILE NAME KEYFILE
VARIABLE LIST F,O,D,S,P,L,DD
INPUT MEDIUM DISK
INPUT FORMAT FIXED(F10.0,F10.2,F10.4,3F10.3,F10.4)

ACCORDING TO YOUR INPUT FORMAT, VARIABLES ARE TO BE READ AS FOLLOWS

VARIABLE	FORMAT	RECORD	COLUMNS
F	F10. 0	1	1- 10
O	F10. 2	1	11- 20
D	F10. 4	1	21- 30
S	F10. 3	1	31- 40
P	F10. 3	1	41- 50
L	F10. 3	1	51- 60
DD	F10. 4	1	61- 70

THE INPUT FORMAT PROVIDES FOR 7 VARIABLES. 7 WILL BE READ.
IT PROVIDES FOR 1 RECORDS (*CARDS*) PER CASE.
A MAXIMUM OF 70 *COLUMNS* ARE USED ON A RECORD.

*PU TIME REQUIRED.. .126 SECONDS

REGRESSION VARIABLES=F,O,D,S,P,L,DD/
STATISTICS REGRESSION=F WITH P/
ALL

FILE YFILE (CREATION DATE = 84/07/20.)

***** MULTIPLE REGRESSION *****

DEPENDENT VARIABLE.. F

MEAN RESPONSE 9937.47002 STD. DEV. 11861.24157

VARIABLE(S) ENTERED ON STEP NUMBER 1.. P

MULTIPLE R	.83809	ANALYSIS OF VARIANCE	DF	SUM OF SQUARES	MEAN SQUARE
R SQUARE	.70240	REGRESSION	1.	41109122429.41235	41109122429.41235
ADJUSTED R SQUARE	.70168	PESIOUAL	415.	17417523026.46277	41969935.00352
STD DEVIATION	6478.42072	COEFF OF VARIABILITY		65.2 PCT	

----- VARIABLES IN THE EQUATION ----- VARIABLES NO1

VARIABLE	B	STD ERROR B	F	BETA	VARIABLE	PARTIAL
			SIGNIFICANCE	ELASTICITY		
P	160129.70	5116.4877	979.48978	.8380931		
(CONSTANT)	-79258.229	2867.5972	763.92802	8.97569		
			0			
			0			

ALL VARIABLES ARE IN THE EQUATION.

COEFFICIENTS AND CONFIDENCE INTERVALS.

VARIABLE	B	STD ERROR B	T	95.0 PCT CONFIDENCE INTERVAL
P	160129.70	5116.4877	31.296801	150072.24 , 170187.16
CONSTANT	-79258.229	2867.5972	-27.639248	-84895.056 , -73621.403

FILE (CREATION DATE = 84/07/20.)

***** MULTIPLE REGRESSION *****

DEPENDENT VARIABLE.. F

SUMMARY TABLE

STEP	VARIABLE ENTERED	VARIABLE REMOVED	F TO ENTER OR REMOVE	SIGNIFICANCE	MULTIPLE R	R SQUARE	R SQUARE CHANGE	SIMPLE R
1	P		979.48978	0	.83809	.70240	.70240	.83809

FILE KEYFILE (CREATION DATE = 04/07/20.)

***** MULTIPLE REGRESSION *****

DEPENDENT VARIABLE.. F

VARIANCE/COVARIANCE MATRIX OF THE UNNORMALIZED REGRESSION COEFFICIENTS.

P .2610E+08

P

FI 'NAME MFYFILE
VAR. E LIST F, O, D, S, P, L, DD
INPUT MEDIUM DISK
INPUT FORMAT FIXED(F10.0, F10.2, F10.4, 3F10.3, F10.4)
REGRESSION VARIABLES=F, O, D, S, P, L, DD/
REGRESSION=F WITH P/
STATISTICS ALL
FINISH

NASA -- LANGLEY RESEARCH CENTER
 HAMPTON, VIRGINIA
 MAINTAINED BY COMPUTER SCIENCES CORPORATION
 S P S S -- STATISTICAL PACKAGE FOR THE SOCIAL SCIENCES
 VERSION 8.3 -- MAY 04, 1982

160000 CM MAXIMUM FIELD LENGTH REQUEST

FILE NAME KEYFILE
 VARIABLE LIST F,O,D,S,P,L,DD
 INPUT MEDIUM DISK
 INPUT FORMAT FIXED(F10.0,F10.2,F10.4,3F10.3,F10.4)

ACCORDING TO YOUR INPUT FORMAT, VARIABLES ARE TO BE READ AS FOLLOWS

VARIABLE	FORMAT	RECORD	COLUMNS
F	F10. 0	1	1- 10
O	F10. 2	1	11- 20
D	F10. 4	1	21- 30
S	F10. 3	1	31- 40
P	F10. 3	1	41- 50
L	F10. 3	1	51- 60
DD	F10. 4	1	61- 70

THE INPUT FORMAT PROVIDES FOR 7 VARIABLES. 7 WILL BE READ.
 IT PROVIDES FOR 1 RECORDS (*CARDS*) PER CASE.
 A MAXIMUM OF 70 *COLUMNS* ARE USED ON A RECORD.

CPU TIME REQUIRED.. .141 SECONDS

REGRESSION VARIABLES=F,O,D,S,P,L,DD/
 STATISTICS REGRESSION=F WITH S/
 ALL

FILE FYFILE (CREATION DATE = 84/07/20.)

***** MULTIPLE REGRESSION *****

VARIABLE	MEAN	STANDARD DEV	CASES
F	9937.4700	11861.2416	417
O	.4106	.2393	417
D	.1801	.0704	417
S	.5392	.0595	417
P	.5570	.0621	417
L	.4469	.1495	417
DD	1.1745	.5440	417

CORRELATION COEFFICIENTS.

A VALUE OF 99.00000 IS PRINTED
IF A COEFFICIENT CANNOT BE COMPUTED.

O	.85347					
D	-.85278	-.84369				
S	.82601	.83750	-.98985			
P	.83809	.83923	-.99548	.98564		
L	-.40372	-.38276	.46501	-.41291	-.46811	
DD	-.02099	.05607	.04592	-.04517	-.04680	.03377
	F	O	D	S	P	L

84/07/20. 14...56.

FILE KEYFILE (CREATION DATE = 84/07/20.)

DEPENDENT VARIABLE.. F * * * * * M U L T I P L E R E G R E S S I O N * * * * *

MEAN RESPONSE 9937.47002 STD. DEV. 11861.24157
VARIABLE(S) ENTERED ON STEP NUMMR 1.. S

MULTIPLE R .82601 ANALYSIS OF VARIANCE DF SUM OF SQUARES MEAN SQUARE
R SQUARE .68230 REGRESSION 1. 39932489075.63892 39932489075.63892
ADJUSTED R SQUARE .68153 RESIDUAL 415. 18594156380.23633 44805196.09695
STD DEVIATION 6693.66836 COEFF OF VARIABILITY 67.4 PCT

----- VARIABLES IN THE EQUATION ----- VARIABLES N

VARIABLE	B	STD ERROR B	F	BETA	SIGNIFICANCE	ELASTICITY	VARIABLE	PARTIAL
S	164622.94	5514.3122	891.24683	.8260120				
(CONSTANT)	-78819.955	2991.0892	0	8.93159				
			694.40628	0				

ALL VARIABLES ARE IN THE EQUATION.

COEFFICIENTS AND CONFIDENCE INTERVALS.

VARIABLE	B	STD ERROR B	T	95.0 PCT CONFIDENCE INTERVAL
S	164622.94	5514.3122	29.853757	153783.47 , 175462.40
CONSTANT	-78819.955	2991.0892	-26.351590	-84699.529 , -72940.380

FILE YFILE (CREATION DATE = 84/07/20.)

DEPENDENT VARIABLE.. F
***** MULTIPLE REGRESSION *****

VARIANCE/COVARIANCE MATRIX OF THE UNNORMALIZED REGRESSION COEFFICIENTS.

S .30408E+08

S

84/07/20. 14.11.56.

FILE KEYFR (CREATION DATE = 84/07/20.)

DEPENDENT VARIABLE.. F
MULTIPLE REGRESSION

SUMMARY TABLE

STEP	VIABLE ENTERED	REMOVED	F TO ENTER OR REMOVE	SIGNIFICANCE	MULTIPLE R	P SQUARE CHANGE	R SQUARE CHANGE	SIMPLE R
1	S		891.24683	0	.82601	.68230	.68230	.82601

FILE KEYFILE (CREATION DATE = 84/07/20.)

***** MULTIPLE REGRESSION *****

DEPENDENT VARIABLE.. F

VARIANCE/COVARIANCE MATRIX OF THE UNNORMALIZED REGRESSION COEFFICIENTS.

S .30408E+08

S

84/07/20.

14.13.52.

NASA -- LANGLEY RESEARCH CENTER
 HAMPTON, VIRGINIA
 MAINTAINED BY COMPUTER SCIENCES CORPORATION
 S P S S -- STATISTICAL PACKAGE FOR THE SOCIAL SCIENCES

VERSION 8.3 -- MAY 04, 1982

16000 CM MAXIMUM FIELD LENGTH REQUEST

FILE NAME KEYFILE
 VARIABLE LIST F,O,D,S,P,L,DD
 INPUT MEDIUM DISK
 INPUT FORMAT FIYED(F10.0,F10.2,F10.4,3F10.3,F10.4)

ACCORDING TO YOUR INPUT FORMAT, VARIABLES ARE TO BE READ AS FOLLOWS

VARIABLE	FORMAT	RECORD	COLUMNS
F	F10. 0	1	1- 10
O	F10. 2	1	11- 20
D	F10. 4	1	21- 30
S	F10. 3	1	31- 40
P	F10. 3	1	41- 50
L	F10. 3	1	51- 60
DD	F10. 4	1	61- 70

THE INPUT FORMAT PROVIDES FOR 7 VARIABLES. 7 WILL BE READ.
 IT PROVIDES FOR 1 RECORDS (*CARDS*) PER CASE.
 A MAXIMUM OF 70 *COLUMNS* ARE USED ON A RECORD.

CPU TIME REQUIRED.. .121 SECONDS

REGRESSION VARIABLES=F,O,D,S,P,L,DD/

FILE KEYFILE (CREATION DATE = 84/07/20.)

***** MULTIPLE REGRESSION *****

VARIABLE	MEAN	STANDARD DEV	CASES
F	9937.4700	11861.2416	417
O	.4106	.2393	417
D	.1801	.0704	417
S	.5392	.0595	417
P	.5570	.0621	417
L	.4469	.1495	417
DD	1.1745	.5440	417

CORRELATION COEFFICIENTS.

A VALUE OF 99.00000 IS PRINTED IF A COEFFICIENT CANNOT BE COMPUTED.

O	.85347					
D	-.85278	-.84369				
S	.82601	.83750	-.98985			
P	.83809	.83923	-.99548	.98564		
L	-.40372	-.38276	.46501	-.41291	-.46811	
DD	-.02099	.05607	.04592	-.04517	-.04680	.03377

F O D S P L

FILE K... (CREATION DATE = 84/07/20.)

***** MULTIPLE REGRESSION *****

DEPENDENT VARIABLE.. F

MEAN RESPONSE 9937.47002 STD. DEV. 11861.24157

VARIABLE(S) ENTERED ON STEP NUMBER 1.. DD

MULTIPLE R	.02099	ANALYSIS OF VARIANCE	DF	SUM OF SQUARES	MEAN SQUARE
R SQUARE	.00044	REGRESSION	1.	25791227.49219	25791227.49219
ADJUSTED R SQUARE	0	RESIDUAL	415.	58500854228.38306	140965913.80333
STD DEVIATION	11872.90671	COEFF OF VARIABILITY	119.5 PCT		

----- VARIABLES IN THE EQUATION ----- VARIABLES NOT J

VARIABLE	B	STD ERROR B	F	BETA	VARIABLE	PARTIAL
				SIGNIFICANCE		
				ELASTICITY		
DD	-457.68936	1070.0199	.18296074	-.0209923		
(CONSTANT)	10475.008	1384.6778	.669	-.05409		
			57.228352			
			0			

ALL VARIABLES ARE IN THE EQUATION.

COEFFICIENTS AND CONFIDENCE INTERVALS.

VARIABLE	B	STD ERROR B	T	95.0 PCT CONFIDENCE INTERVAL
DD	-457.68936	1070.0199	-.42773910	-2561.0240 , 1645.6453
CONSTANT	10475.008	1384.6778	7.5649423	7753.1513 , 13196.865

84/07/20. 14.13.52.

FILE KEYFMS (CREATION DATE = 84/07/20.)

***** MULTIPLE REGRESSION *****

DEPENDENT VARIABLE.. F

SUMMARY TABLE

STEP	VARIABLE ENTERED	REMOVED	F TO ENTER OR REMOVE	SIGNIFICANCE	MULTIPLE R	P SQUARE	R SQUARE	CHANGE	SIMPLE R
1	DD		.18296	.669	.02099	.00044	.00044	-.02099	

ORIGINAL PAGE IS OF POOR QUALITY

84/07/20. 14. 52.

FILE KEYFR (CREATION DATE = 84/07/20.)

***** MULTIPLE REGRESSION *****

DEPENDENT VARIABLE.. FF

VARIANCE/COVARIANCE MATRIX OF THE UNNORMALIZED REGRESSION COEFFICIENTS.

DD .3449E+07

SD

ORIGINAL PAGE IS
OF POOR QUALITY

FILE .ME KEYFILE
VARIABLE LIST F,O,D,S,P,L,DD
INPUT MEDIUM DISK
INPUT FORMAT FIXED(F10.0,F10.2,F10.4,3F10.3,F10.4)
REGRESSION VARIABLES=F,O,D,S,P,L,DD/
REGRESSION=F WITH DD/
STATISTICS ALL
FINISH

NASA -- LANGLEY RESEARCH CENTER
HAMPTON, VIRGINIA
MAINTAINED BY COMPUTER SCIENCES CORPORATION

S P S S --- STATISTICAL PACKAGE FOR THE SOCIAL SCIENCES

VERSION 8.3 -- MAY 04, 1982

160000 CM MAXIMUM FIELD LENGTH REQUEST

FILE NAME KEYFILE
VARIABLE LIST F,O,D,S,P,L,DD
INPUT MEDIUM DISK
INPUT FORMAT FIXED(F10.0,F10.2,F10.4,3F10.3,F10.4)

ACCORDING TO YOUR INPUT FORMAT, VARIABLES ARE TO BE READ AS FOLLOWS

VARIABLE	FORMAT	RECORD	COLUMNS
F	F10. 0	1	1- 10
O	F10. 2	1	11- 20
D	F10. 4	1	21- 30
S	F10. 3	1	31- 40
P	F10. 3	1	41- 50
L	F10. 3	1	51- 60
DD	F10. 4	1	61- 70

THE INPUT FORMAT PROVIDES FOR 7 VARIABLES. 7 WILL BE READ.
IT PROVIDES FOR 1 RECORDS (*CARDS*) PER CASE.
A MAXIMUM OF 70 *COLUMNS* ARE USED ON A RECORD.

CPU TIME REQUIRED.. .126 SECONDS

REGRESSION VARIABLES=F,O,D,S,P,L,DD/
REGRESSION=F WITH D/
STATISTICS ALL

00053400 CM NEEDED FOR REGRESSION

FILE NAME (CREATION DATE = 84/07/20.)

***** MULTIPLE REGRESSION *****

VARIABLE	MEAN	STANDARD DEV	CASES
F	9937.4700	11861.2416	417
D	.4106	.2393	417
S	.1801	.0704	417
P	.5392	.0595	417
L	.5570	.0621	417
	.4469	.1495	417
00	1.1745	.5440	417

CORRELATION COEFFICIENTS.

A VALUE OF 99.0000 IS PRINTED IF A COEFFICIENT CANNOT BE COMPUTED.

O	.85347					
D	-.85278	-.84369				
S	.82601	.83750	-.98985			
P	.83809	.83923	-.99548	.98564		
L	-.40372	-.38276	.46501	-.41291	-.46811	
00	-.02099	.05607	.04592	-.04517	-.04680	.03377
	F	O	D	S	P	L

ORIGINAL PAGE IS OF POOR QUALITY

FILE (CREATION DATE = 04/07/20.)

***** MULTIPLE REGRESSION *****

DEPENDENT VARIABLE.. F

MEAN RESPONSE 9937.47002 STD. DEV. 11861.24197

VARIABLE(S) ENTERED ON STEP NUMBER 1.. 0

MULTIPLE R	.65278	ANALYSIS OF VARIANCE	DF	SUM OF SQUARES	MEAN SQUARE
R SQUARE	.72724	REGRESSION	1.	42562742936.22998	42562742936.22998
ADJUSTED R SQUARE	.72658	RESIDUAL	415.	15963902519.64526	38467234.98710
STD DEVIATION	6202.19598	COEFF OF VARIABILITY	62.4 PCT		

----- VARIABLES IN THE EQUATION ----- VARIABLES NOT

VARIABLE	B	STD ERROR B	F	SIGNIFICANCE	BETA	ELASTICITY	VARIABLE	PARTIAL
0	-143634.81	4318.0770	1106.4674		-.8527819			
(CONSTANT)	35801.380	834.75861	1839.4065		-2.60267			

ALL VARIABLES ARE IN THE EQUATION.

COEFFICIENTS AND CONFIDENCE INTERVALS.

VARIABLE	B	STD ERROR B	T	95.0 PCT CONFIDENCE INTERVAL
0	-143634.81	4318.0770	-33.263605	-152122.84 , -135146.78
CONSTANT	35801.380	834.75861	42.888303	34160.498 , 37442.263

FILL KEYFILE
VARIABLE LIST
INPUT MEDIUM
INPUT FORMAT
REGRESSION
STATISTICS
FINISH

KEYFILE
F, O, D, S, P, L, DD
DISK
FIXED(F10.0, F10.2, F10.4, 3F10.3, F10.4)
VARIABLES=F, O, D, S, P, L, DD/
REGRESSION=F WITH D/
ALL

NASA -- LANGLEY RESEARCH CENTER
 HAMPTON, VIRGINIA
 MAINTAINED BY COMPUTER SCIENCES CORPORATION

S P S S --- STATISTICAL PACKAGE FOR THE SOCIAL SCIENCES

VERSION 8.3 -- MAY 04, 1982

160000 CM MAXIMUM FIELD LENGTH REQUEST

FILE NAME KEYFILE
 VARIABLE LIST F,O,D,S,P,L,DD
 INPUT MEDIUM DISK
 INPUT FORMAT FIXED(F10.0,F10.2,F10.4,3F10.3,F10.4)

ACCORDING TO YOUR INPUT FORMAT, VARIABLES ARE TO BE READ AS FOLLOWS

VARIABLE	FORMAT	RECORD	COLUMNS
F	F10. 0	1	1- 10
O	F10. 2	1	11- 20
D	F10. 4	1	21- 30
S	F10. 3	1	31- 40
P	F10. 3	1	41- 50
L	F10. 3	1	51- 60
DD	F10. 4	1	61- 70

THE INPUT FORMAT PROVIDES FOR 7 VARIABLES. 7 WILL BE READ.
 IT PROVIDES FOR 1 RECORDS (*CARDS*) PER CASE.
 A MAXIMUM OF 70 *COLUMNS* ARE USED ON A RECORD.

CPU TIME REQUIRED.. .119 SECONDS

REGRESSION VARIABLES=F,O,D,S,P,L,DD/
 STATISTICS REGRESSION=F WITH L/
 ALL

00053400 CM NEEDED FOR REGRESSION

***** MULTIPLE REGRESSION *****

ARIABLE	MEAN	STANDARD DEV	CASES
	9937.4700	11861.2416	417
	.4106	.2393	417
	.1801	.0704	417
	.5392	.0595	417
	.5570	.0621	417
	.4469	.1495	417
D	1.1745	.5440	417

CORRELATION COEFFICIENTS.

VALUE OF 99.0000 IS PRINTED
IF A COEFFICIENT CANNOT BE COMPUTED.

	.85347			
	-.85278	-.84369		
	.82601	.83750	-.98985	
	.83809	.83923	-.99548	.98564
	-.40372	-.38276	.46501	-.41291
D	-.02099	.05607	.04592	-.04517
				-.46811
				-.04680
				.03377

F O D S P L

84/07/20. 14.13.00. P

FILE KEYFILE (CREATION DATE = 84/07/20.)

DEPENDENT VARIABLE.. F MULTIPLE REGRESSION

MEAN RESPONSE 9937.47002 STD. DEV. 11861.24157

VARIABLE(S) ENTERED ON STEP NUMBER 1.. 1

MULTIPLE R	.40372	ANALYSIS OF VARIANCE	DF	SUM OF SQUARES	MEAN SQUARE
R SQUARE	.16299	REGRESSION	1.	9539237292.36084	9539237292.36084
ADJUSTED R SQUARE	.16097	RESIDUAL	415.	48987408163.51440	118041947.38196
STD DEVIATION	10864.71110	COEFF OF VARIABILITY	109.3 PCT		

----- VARIABLES IN THE EQUATION -----

VARIABLE	B	STD ERROR B	F	BETA	VARIABLE	PARTIAL
			SIGNIFICANCE	ELASTICITY		
L	-32032.843	3563.3366	80.812266	-.4037198		
(CONSTANT)	24251.849	1678.8682	209.66832	-1.44045		
			0			
			0			

ALL VARIABLES ARE IN THE EQUATION.

COEFFICIENTS AND CONFIDENCE INTERVALS.

VARIABLE	B	STD ERROR B	T	95.0 PCT CONFIDENCE INTERVAL
L	-32032.843	3563.3366	-8.9895643	-39037.282 , -25028.404
CONSTANT	24251.849	1678.8682	14.445356	20951.704 , 27551.995

FILE KFYFILE (CREATION DATE = 84/07/20.)

DEPENDENT VARIABLE.. F

M U L T I P L E R E G R E S S I O N

VARIANCE/COVARIANCE MATRIX OF THE UNNORMALIZED REGRESSION COEFFICIENTS.

L .12697E+08

L

ORIGINAL PAGE IS
OF POOR QUALITY

FILE NAME OFFICE
VARIABLES F0,0,S,P,L,DD
INPUT MEDIUM DISK
INPUT FORMAT MIXED(F10.0,F10.2,F10.4,F10.3,F10.4)
REGRESSION VARIABLES=F,0,D,S,P,L,DD/
REGRESSION=F WITH L/
STATISTICS ALL
FINISH

CONCLUSION

The principal conclusions from this investigation can be summarized as follows:

1. Flow rate measurements indicate that the vortex tube sound frequency is linearly proportional to the frequency response.
2. The vortex tube whistle frequency is dependent upon the geometrical tube parameters to such an extent that: an increase in vortex tube length produces a decrease in frequency response and that an increase in the exhaust nozzle length produces an increase in the frequency precession.
3. An increase in the vortex tube diameter produces a decrease in frequency precession.
4. An increase in swirler diameter produces a decrease in frequency.
5. An increase in the location distance of the microphone pickup signal point from the inside edge of the exit nozzle produces an increase in frequency response.

The experimental results indicate that those parameters most significantly effecting frequency are in descending order of importance microphone location, vortex tube diameter, exit nozzle length, vortex tube length and swirler diameter.

REFERENCES

1. Vonnegut, Bernard: A Vortex Whistle. J. Acoust. Soc. America, Vol. 26, No. 1 pp 10-20.
2. Michelson, Irving: Theory of Vortex Whistle. J. Acoust. Soc. America, Vol. 27, No. 5 pp. 930-931.
3. Nicklas, J.P.,: Investigation of a Vortex Tube True Airspeed Sensor. Cornell Aeronautical Laboratories. Report 1H-942-P-2, 1957.
4. Chanaud, R.C.,: Experiments Concerning the Vortex Whistle. J. Acoust. Soc. America, Vol. 35, No. 7 1963, pp. 953-960.
5. Powell, Alan: Theory of Vortex Sound. J. Acoust. Soc. America, Vol. 36, No. 1, Jan. 1964 pp. 177-195.
6. Gove, R.W. and Ranz, W.E.,: Backflows in Rotating Fluids Moving Axially Through Expanding Cross Sections. Amer. Inst. Chem. Eng.
7. Bossel, Hartmut H.,: Vortex Breakdown Flowfield. The Physics of Fluids. Vol. 12 No. 3 March 1969 pp. 498-508.
8. Chanaud, R.C.,: Aerodynamic Whistles. Sci. Am., Vol. 222, No. 1, 1970, pp. 40-46.
9. Wilson, T.A.,: Experiments on the Fluid Mechanics of Whistling. J. Acoust. Soc. Ame., Vol. 50. No. 1 (Part 2) 1971 pp. 366-372.
10. Randall, J.D. and Leibovich S.,: J. Fluid Mech., Vol. 58, Part 3, 1973 pp. 495-515.
11. Kubo, I. and Gouldin, F.C.,: Numerical Calculations of Turbulent Swirling Flow. Transaction of the ASME. September 1975 pp. 310-315.
12. Bossel, H.H.,: Swirling Flows in Streamtubes of Variable Cross Section. J. AIAA Vol. 1 September 1972 pp. 1161-1164.
13. Letter To The Editor: J. Sound and Vibration, Vol 38, 1975, No. 1 pp. 149-155.
14. Calif, B.,: Laminar Swirling Pipe Flow. J. Applied Mech. July 1952. Paper No. 53 - APM -24.
15. Shen, Y.C. and Goglia, G.L.,: Experimental and Analytical Studies in Fluidics. Progress Report, for NASA Grant NSG 1177, June 1978.

Table 1. Vortex tube dimensions.

Vortex Tube	L	S	P	P-S	D
1	0.403	0.472	0.490	0.018	0.25
2	0.403	0.472	0.500	0.028	0.25
3	0.631	0.494	0.497	0.002	0.25
4	0.641	0.484	0.500	0.016	0.25
5	0.26	0.582	0.615	0.033	0.125
6	0.269	0.601	0.600	0.001	0.125
7	0.533	0.592	0.612	0.020	0.125
8	0.543	0.582	0.600	0.018	0.125
9	0.206	0.605	0.625	0.226	0.093
10	0.200	0.610	0.639	0.229	0.093
11	0.522	0.603	0.625	0.544	0.093
12	0.512	0.613	0.635	0.534	0.093

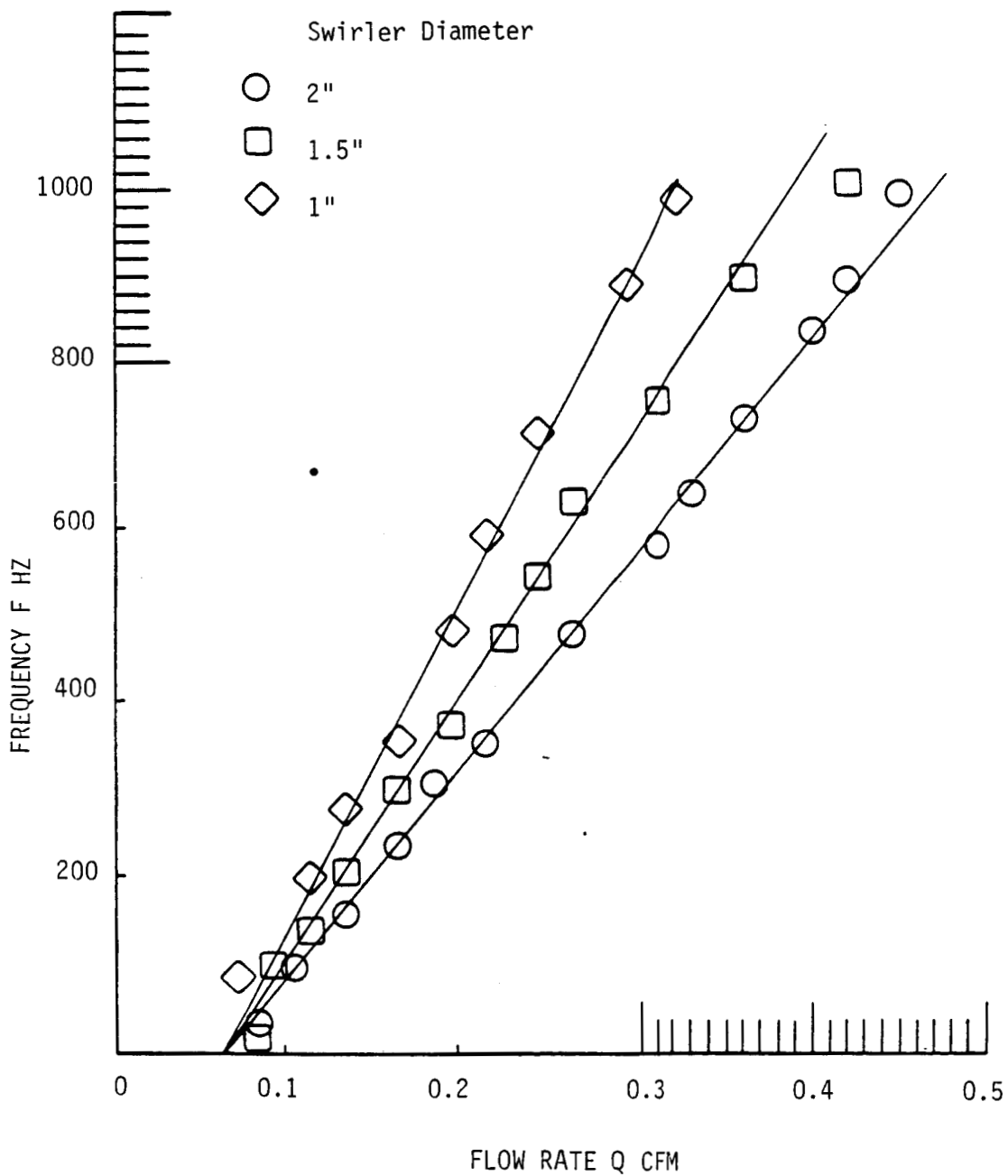

Figure 1. Flow rate vs. frequency response for sensor 1 with three swirlers having various diameters.

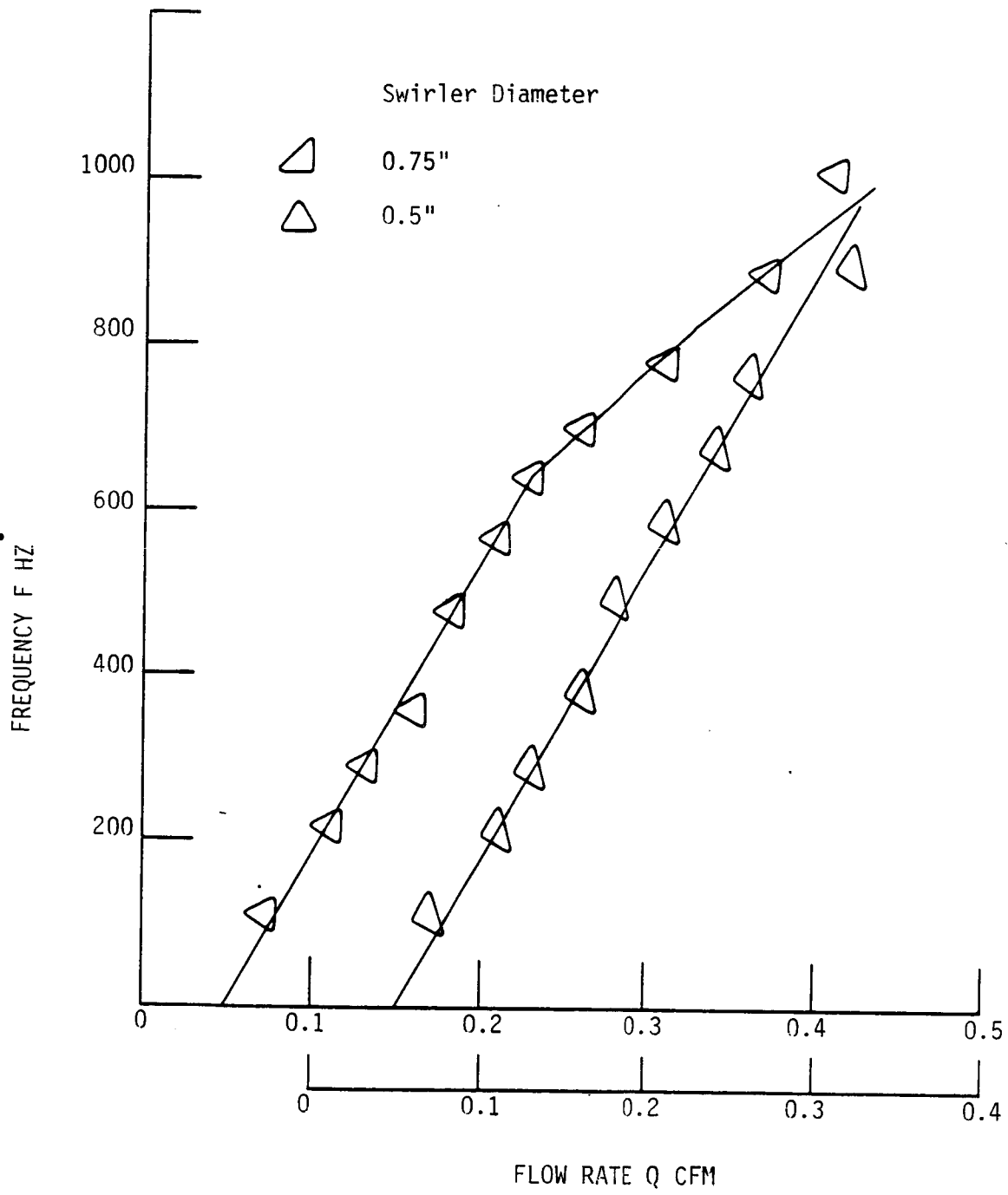

Figure 2. Flow rate vs. frequency for sensor 1 with two swirlers having various diameters.

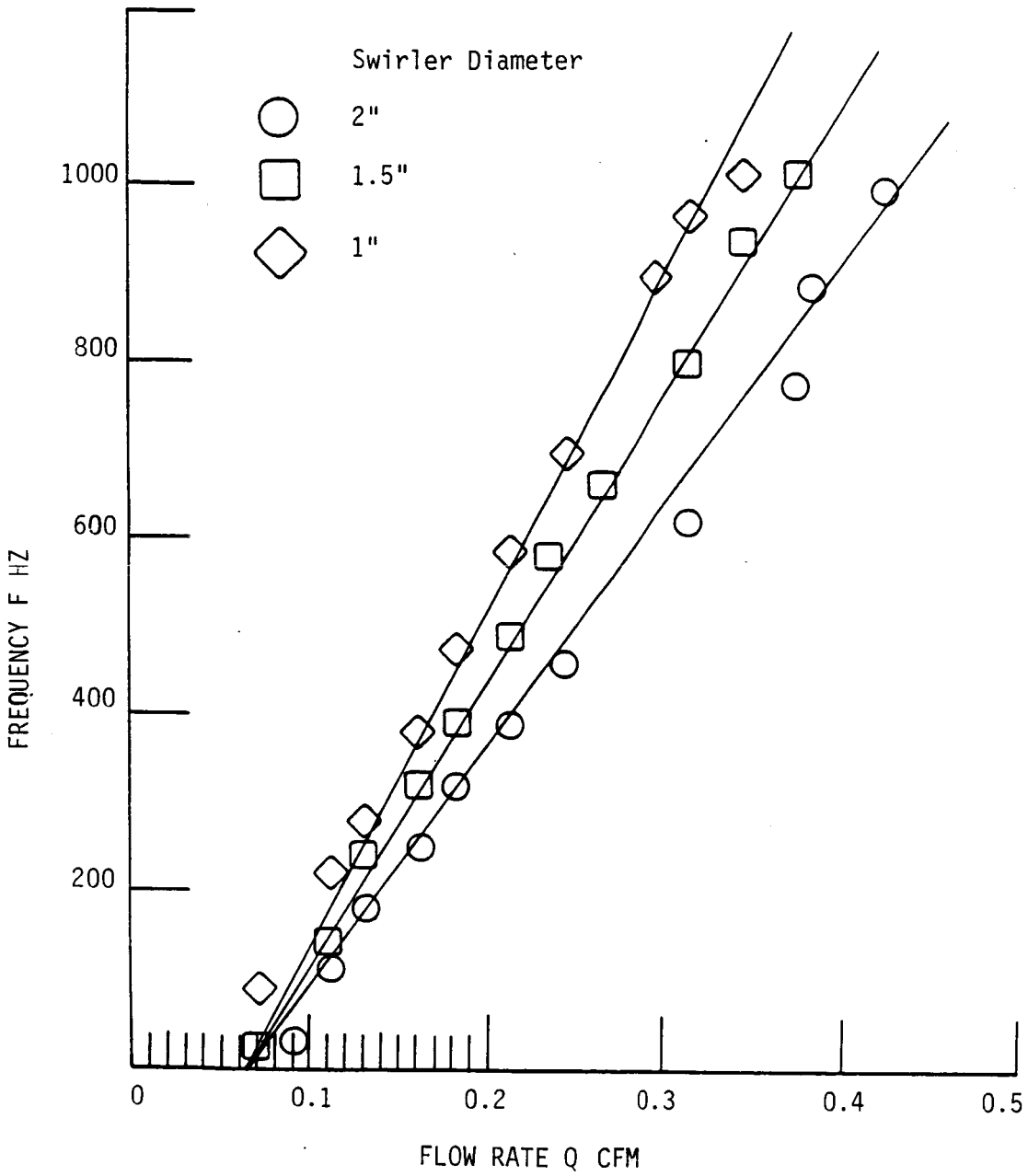

Figure 3. Flow rate vs. frequency for sensor 2 with three swirlers having various diameters.

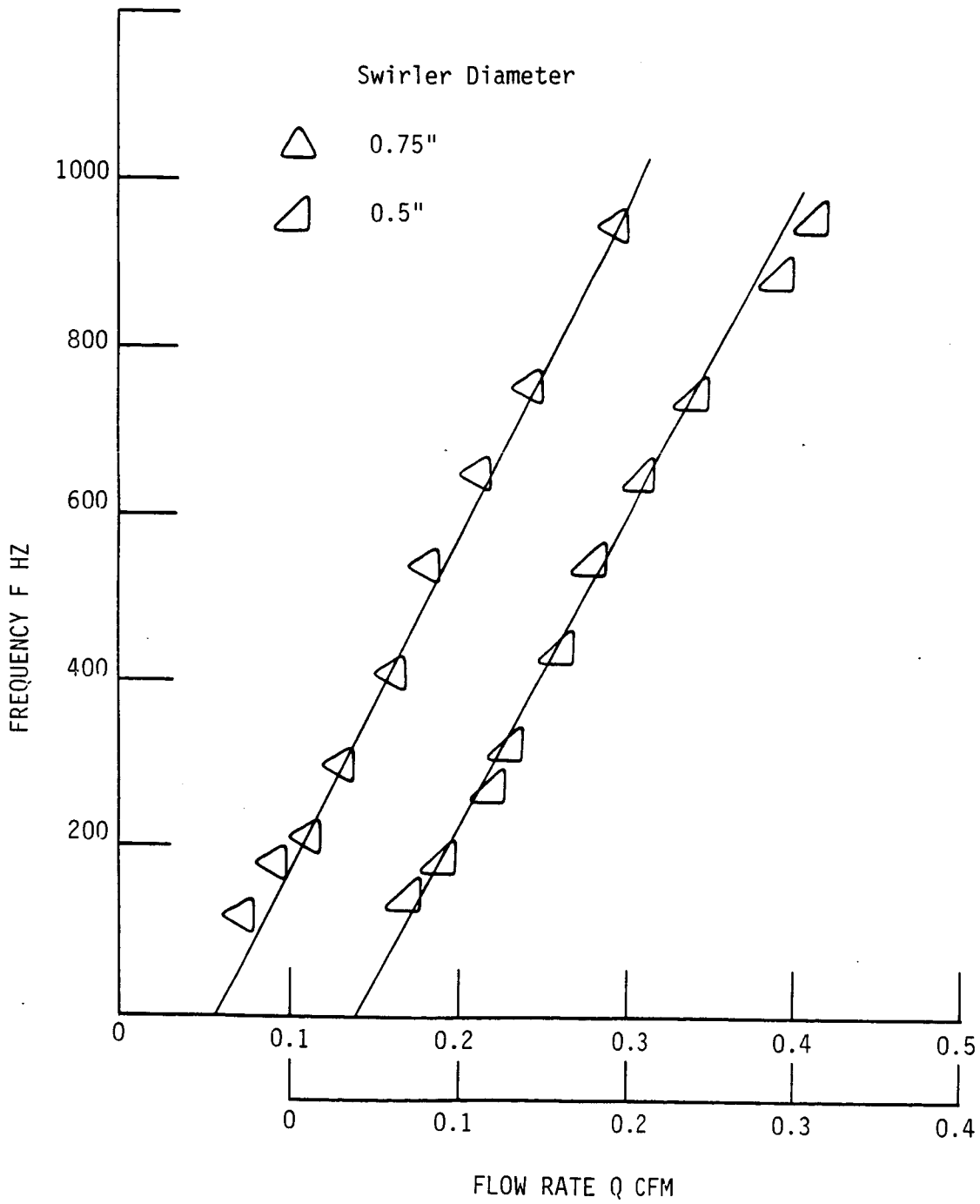

Figure 4. Flow rate vs. frequency response for sensor 2 with three swirlers having various diameters.

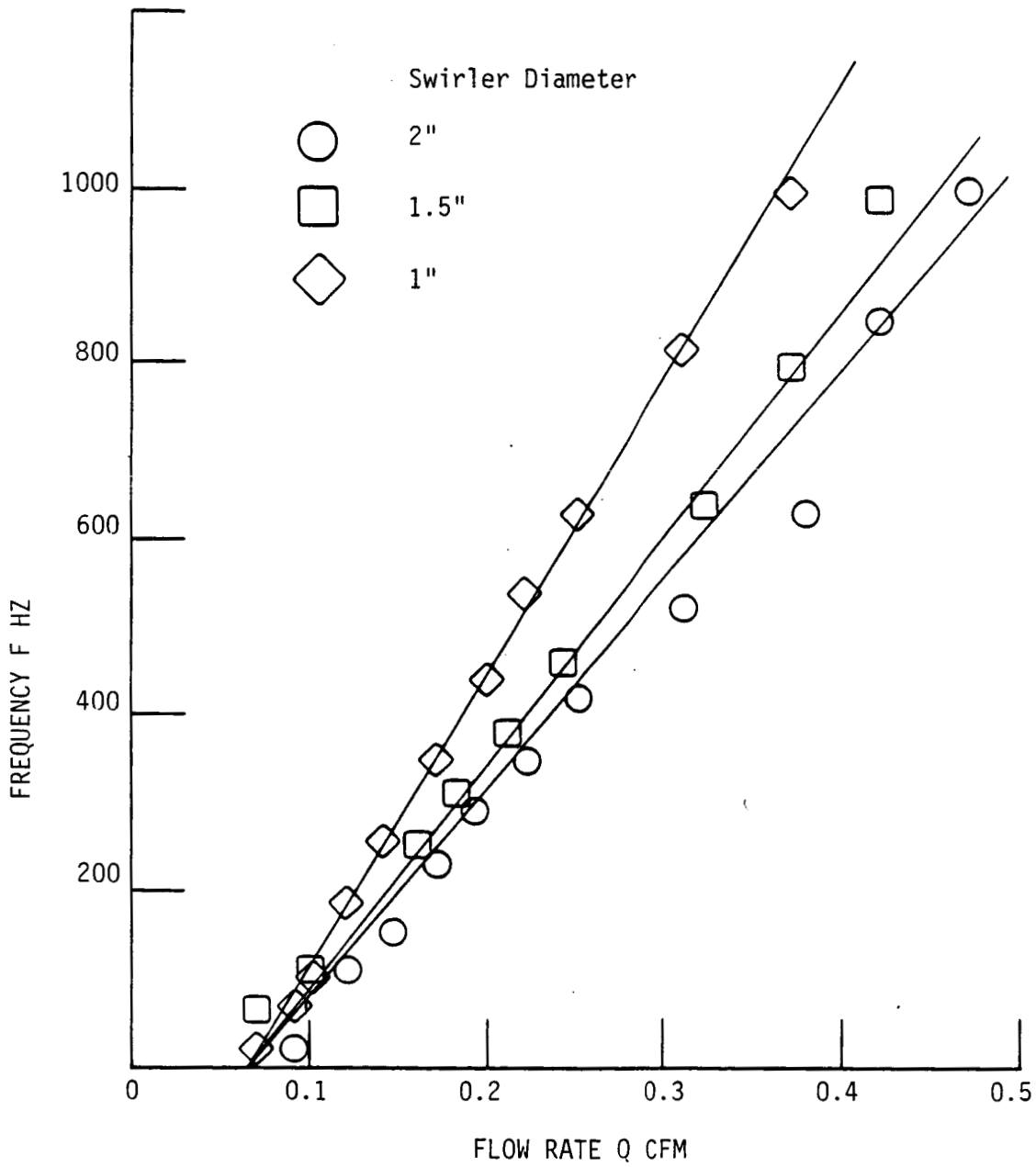

Figure 5. Flow rate vs. frequency for sensor 3 with three swirlers having various diameters.

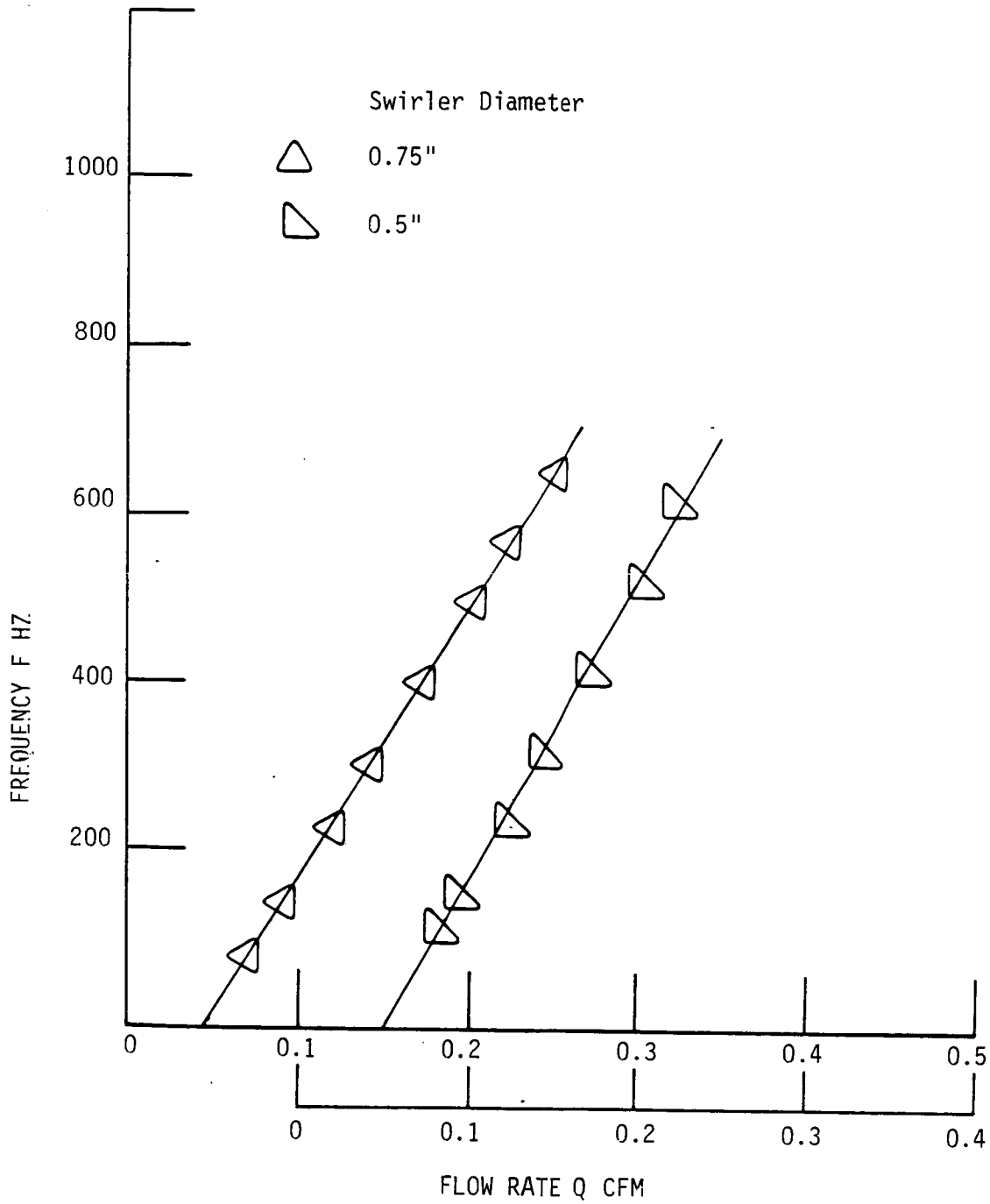

Figure 6. Flow rate vs. frequency for sensor 3 with two swirlers having various diameters.

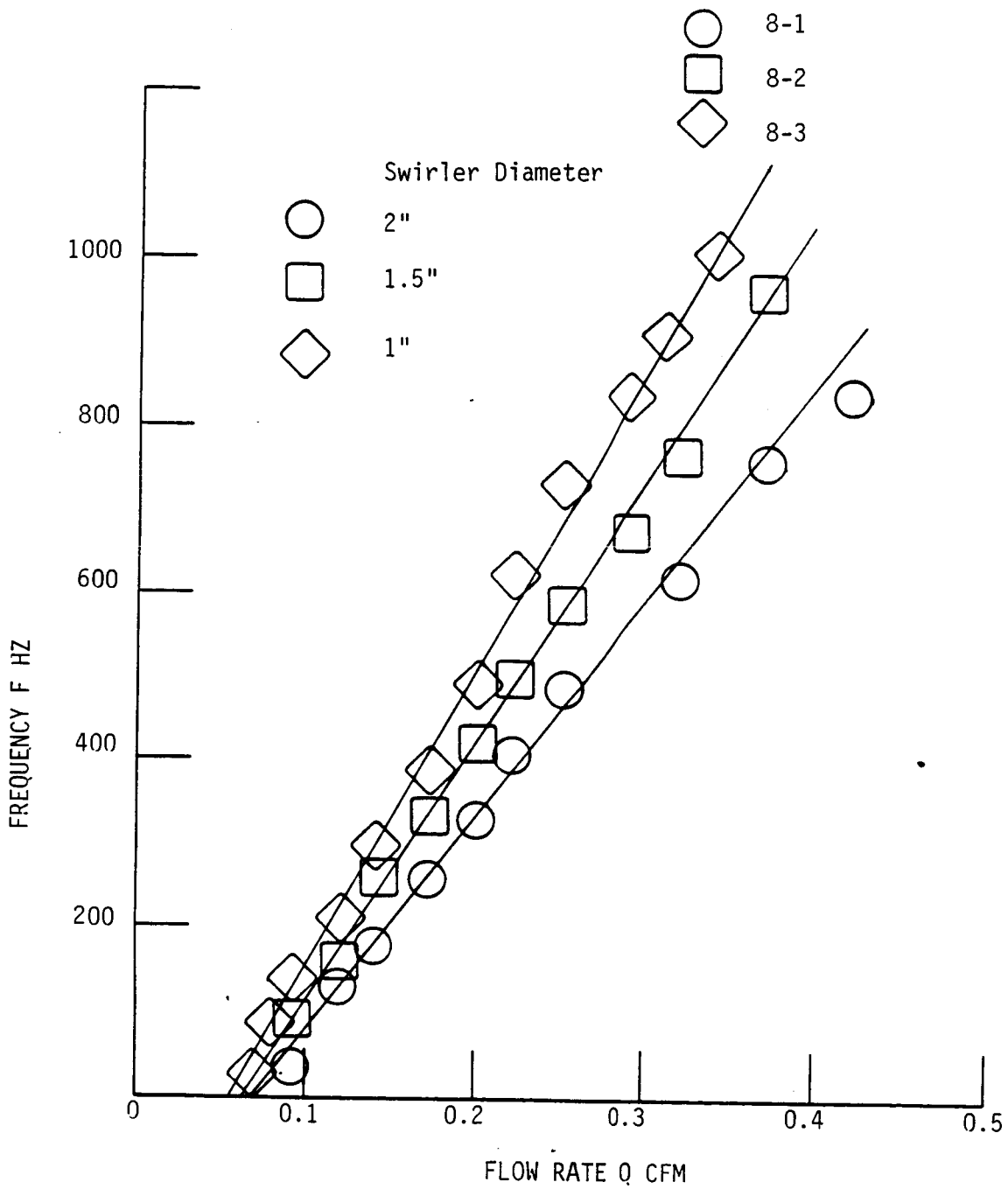

Figure 7. Flow rate vs. frequency for sensor 4 with three swirlers having various diameter.

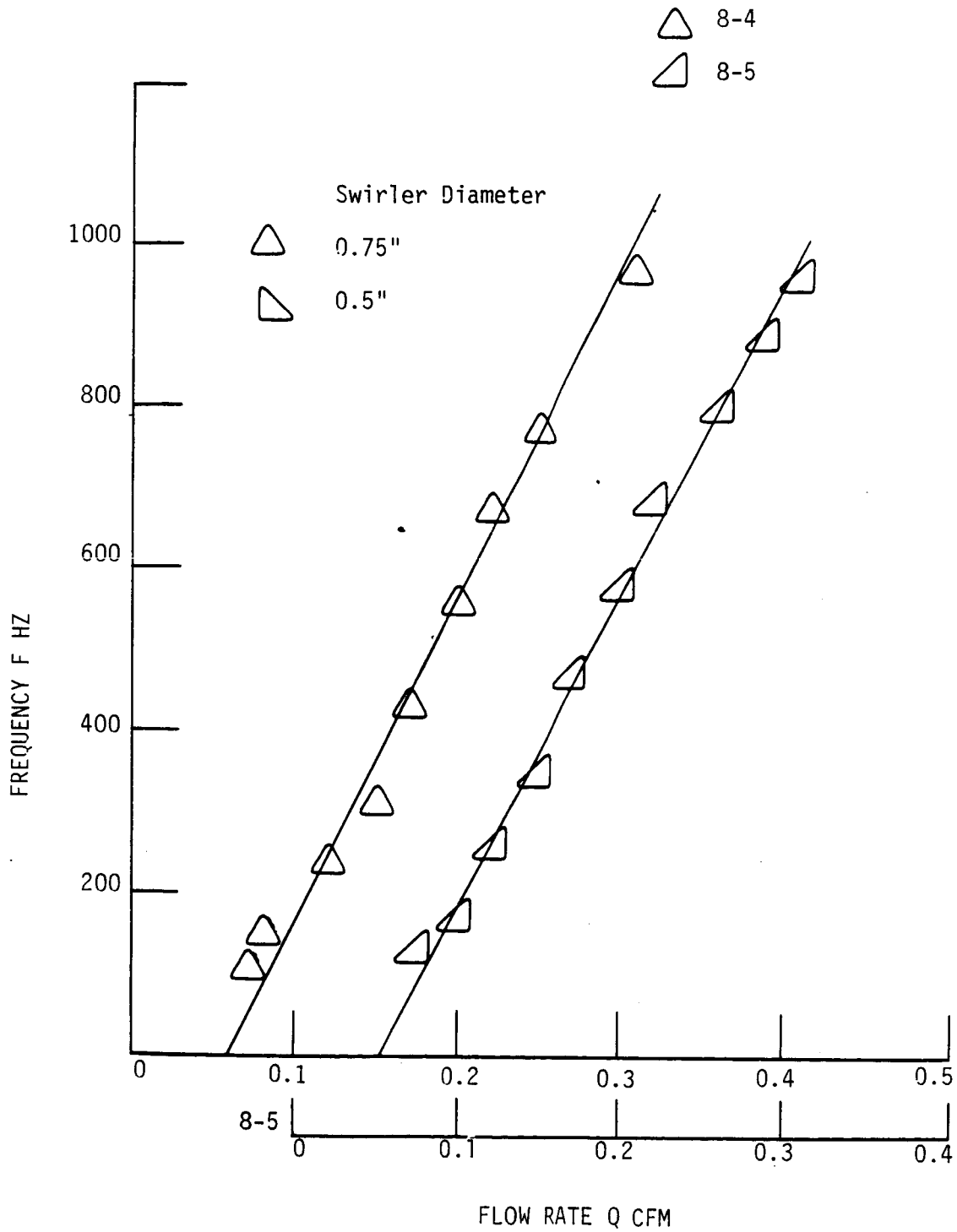

Figure 8. Flow rate vs. frequency for sensor 4 with two swirlers having various diameters.

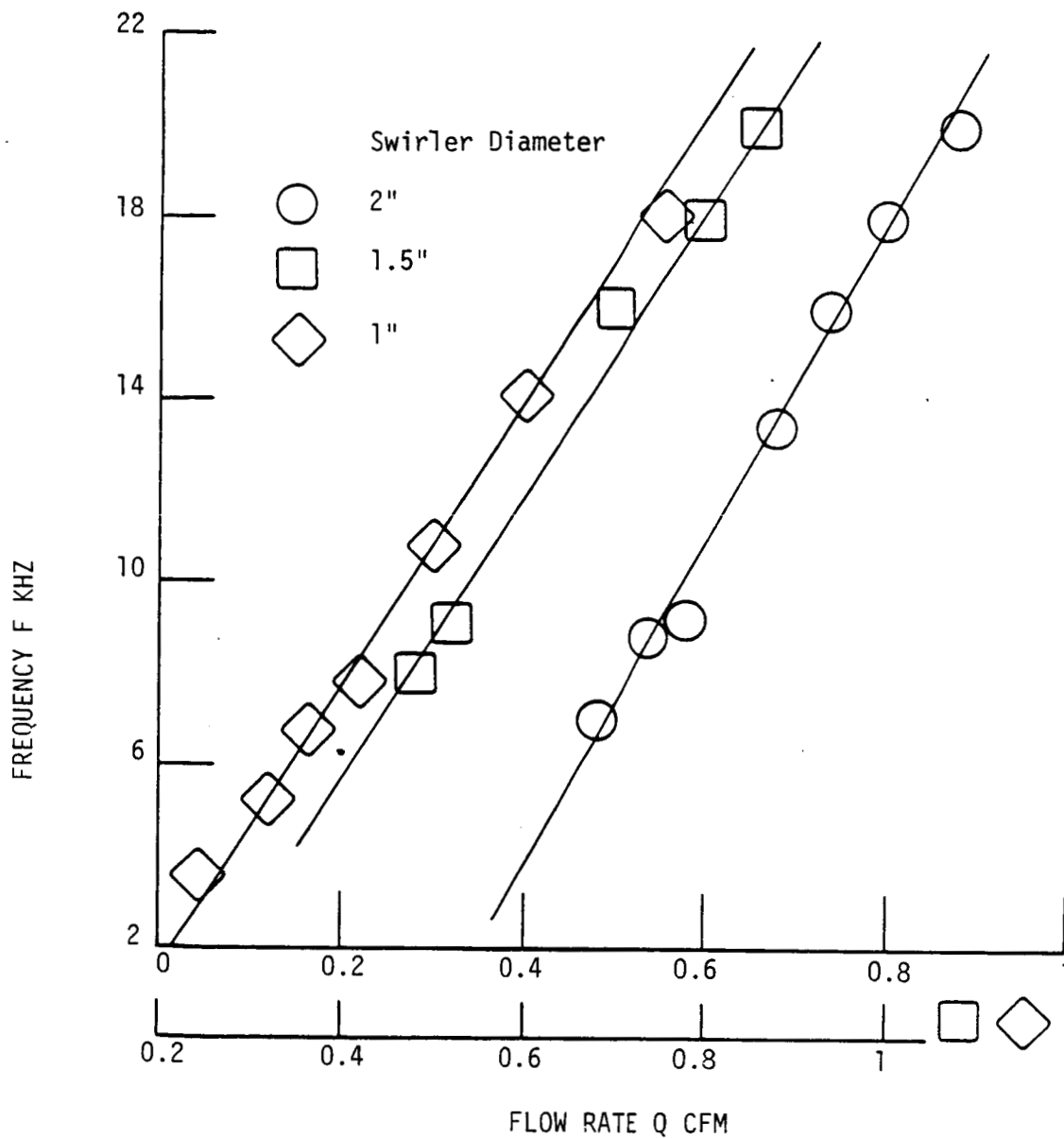

Figure 9. Flow rate vs. frequency for sensor 5 with three swirlers having various diameters.

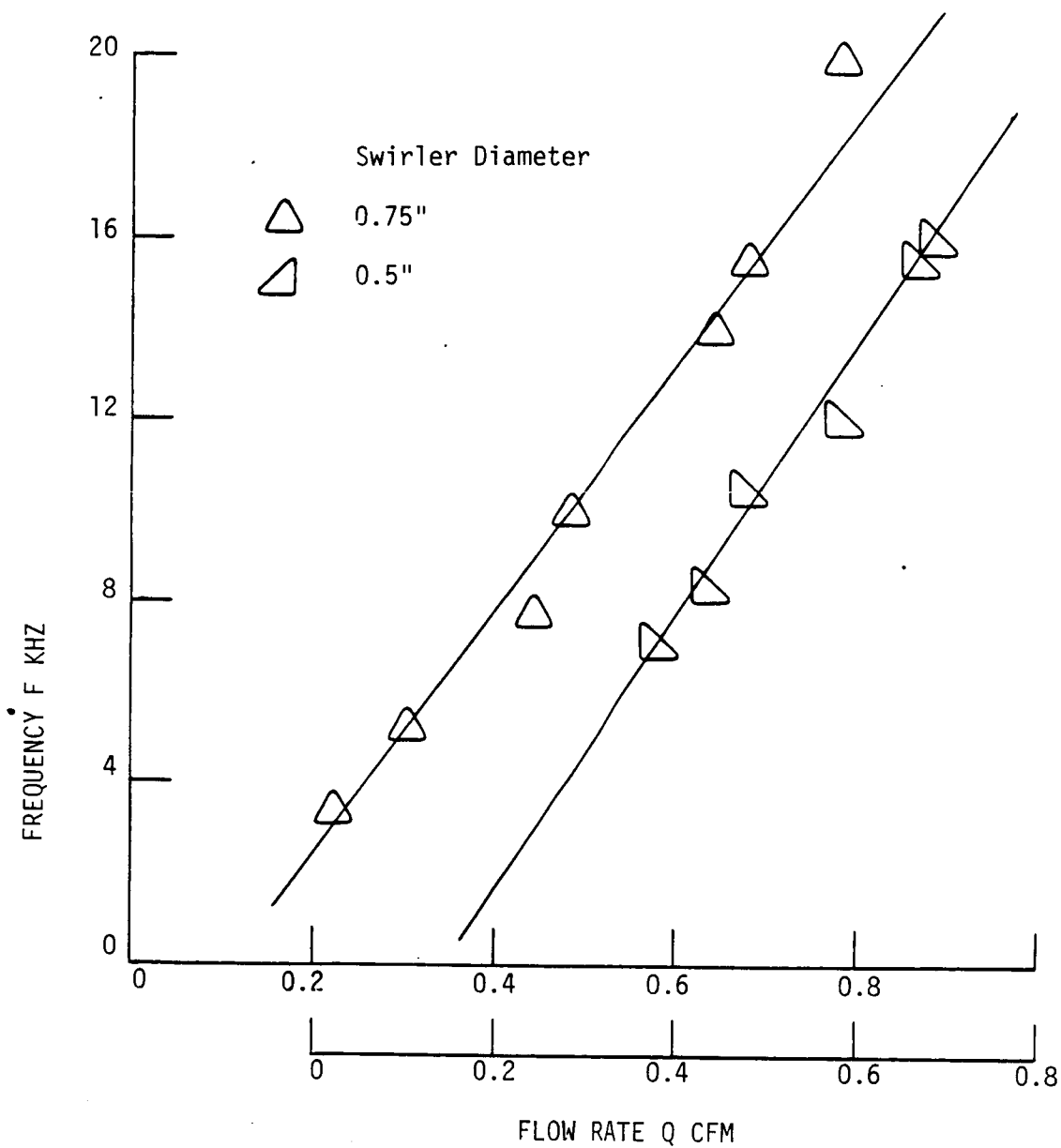

Figure 10. Flow rate vs. frequency for sensor 5 with two swirlers having various diameters.

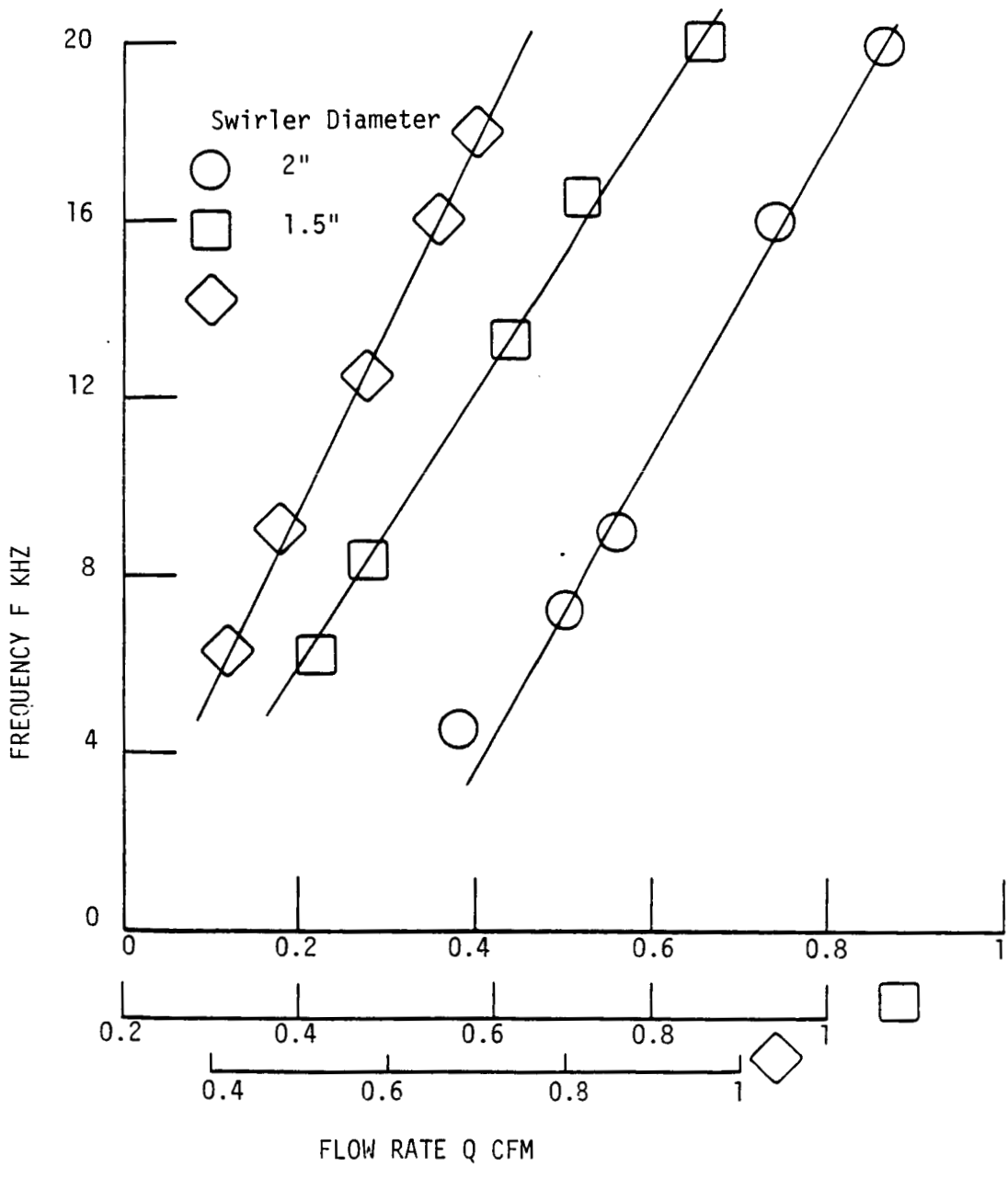

Figure 11. Flow rate vs. frequency for sensor 6 with three swirlers having various diameters.

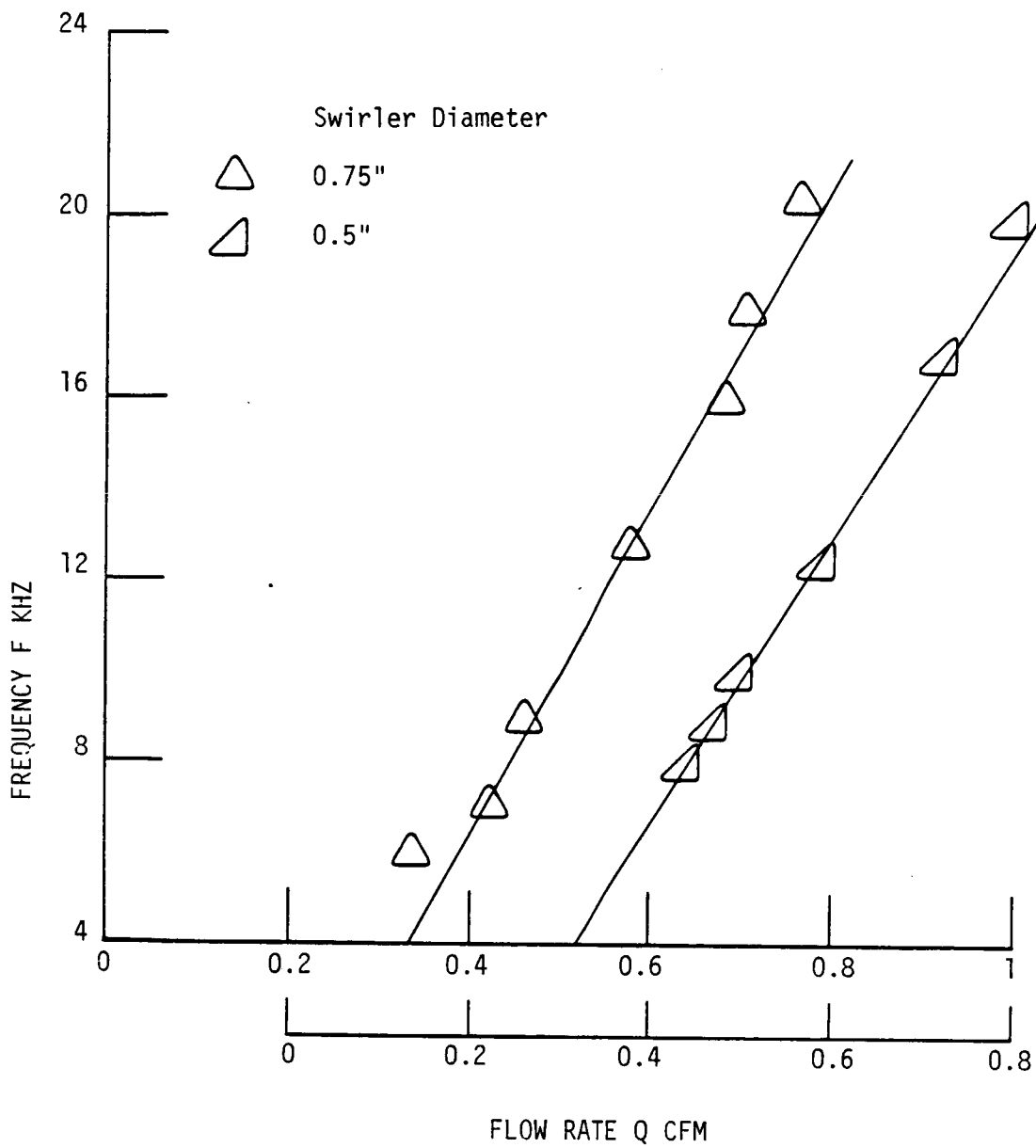

Figure 12. Flow rate vs. frequency for sensor 6 with two swirlers having various diameters.

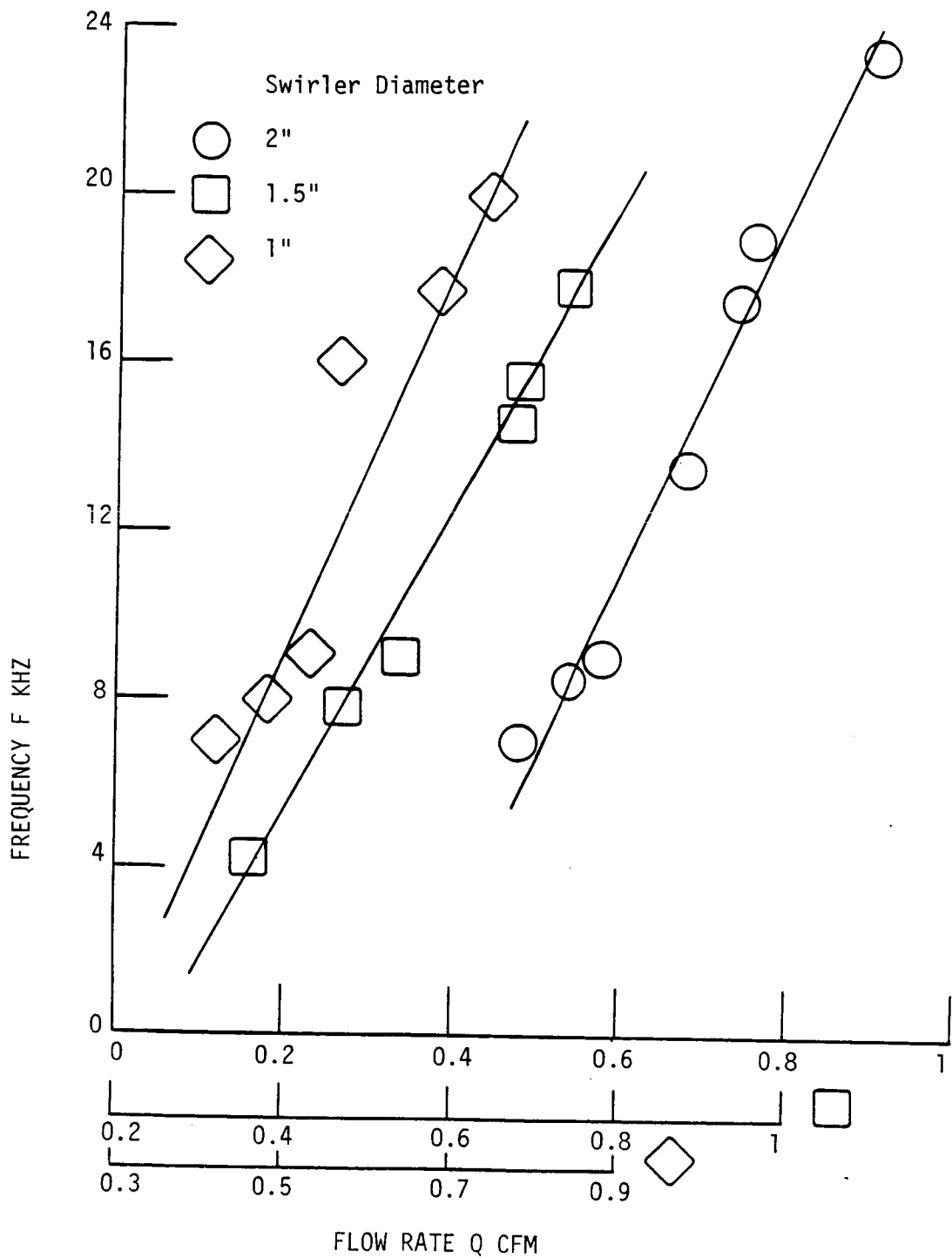

Figure 13. Flow rate vs. frequency for sensor 7 with three swirlers having various diameters.

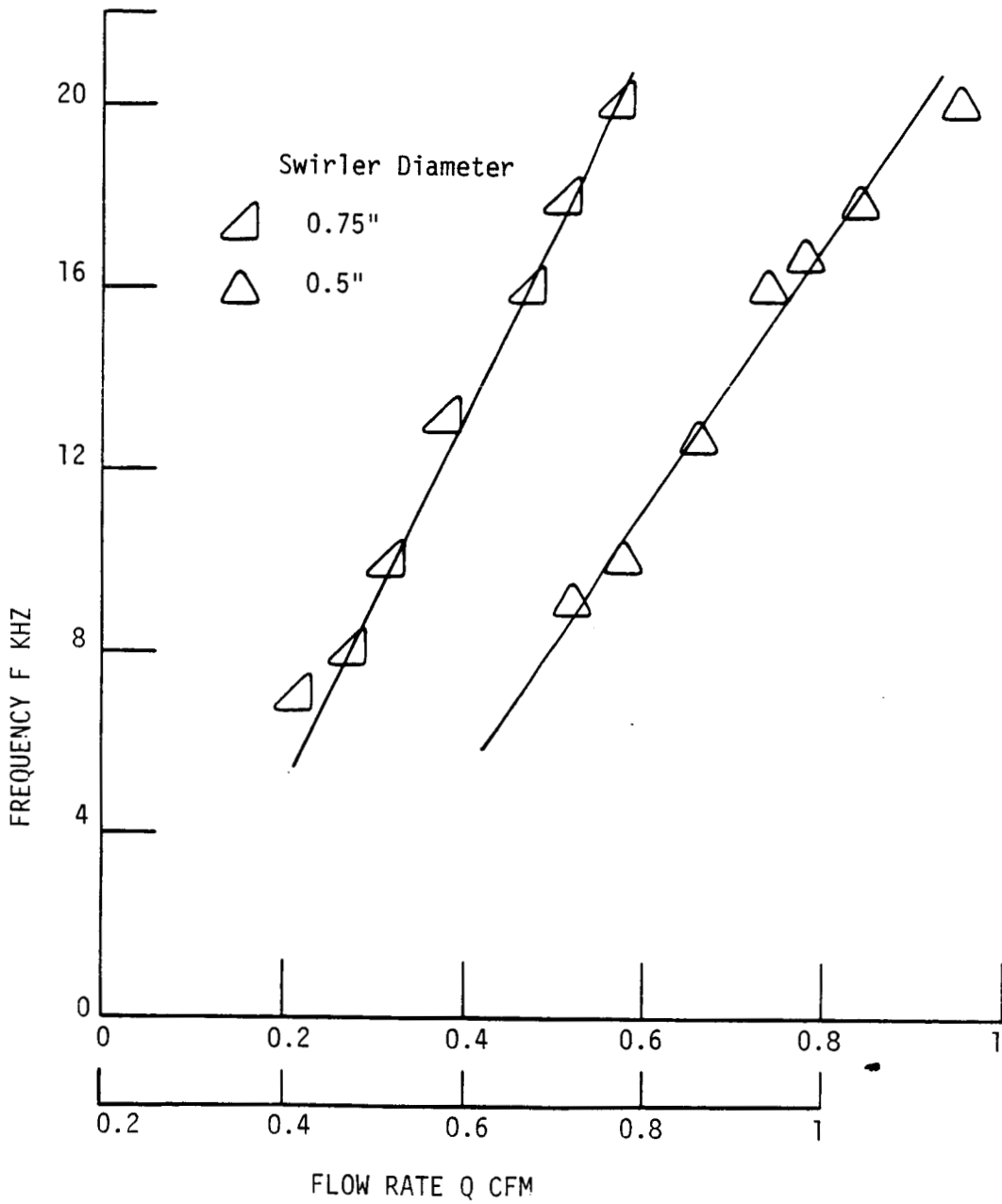

Figure 14. Flow rate vs. frequency for sensor 7 with two swirlers having various diameters.

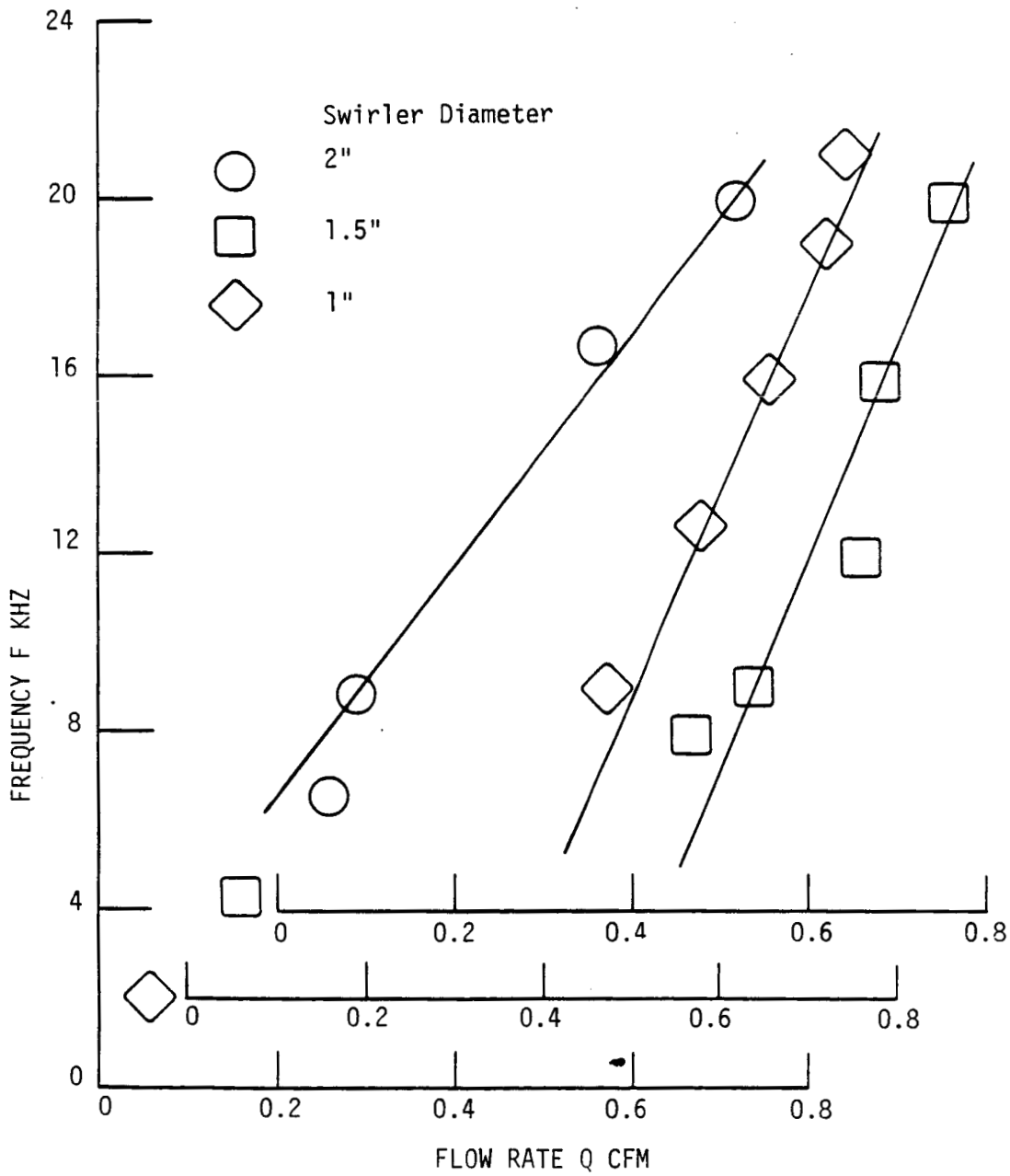

Figure 15. Flow rate vs. frequency for sensor 8 with three swirlers having various diameters.

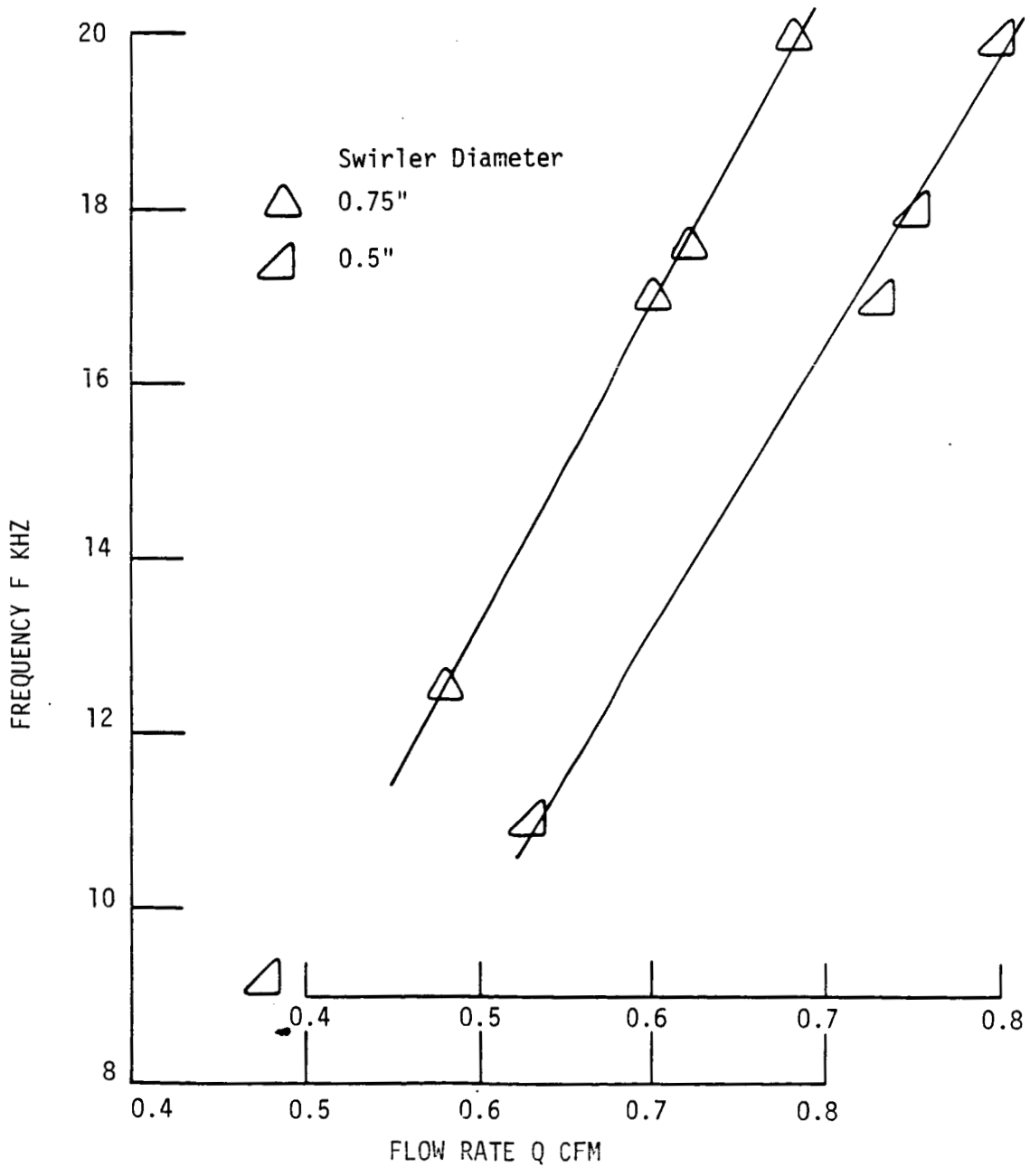

Figure 16. Flow rate vs. frequency for sensor 8 with two swirlers having various diameters.

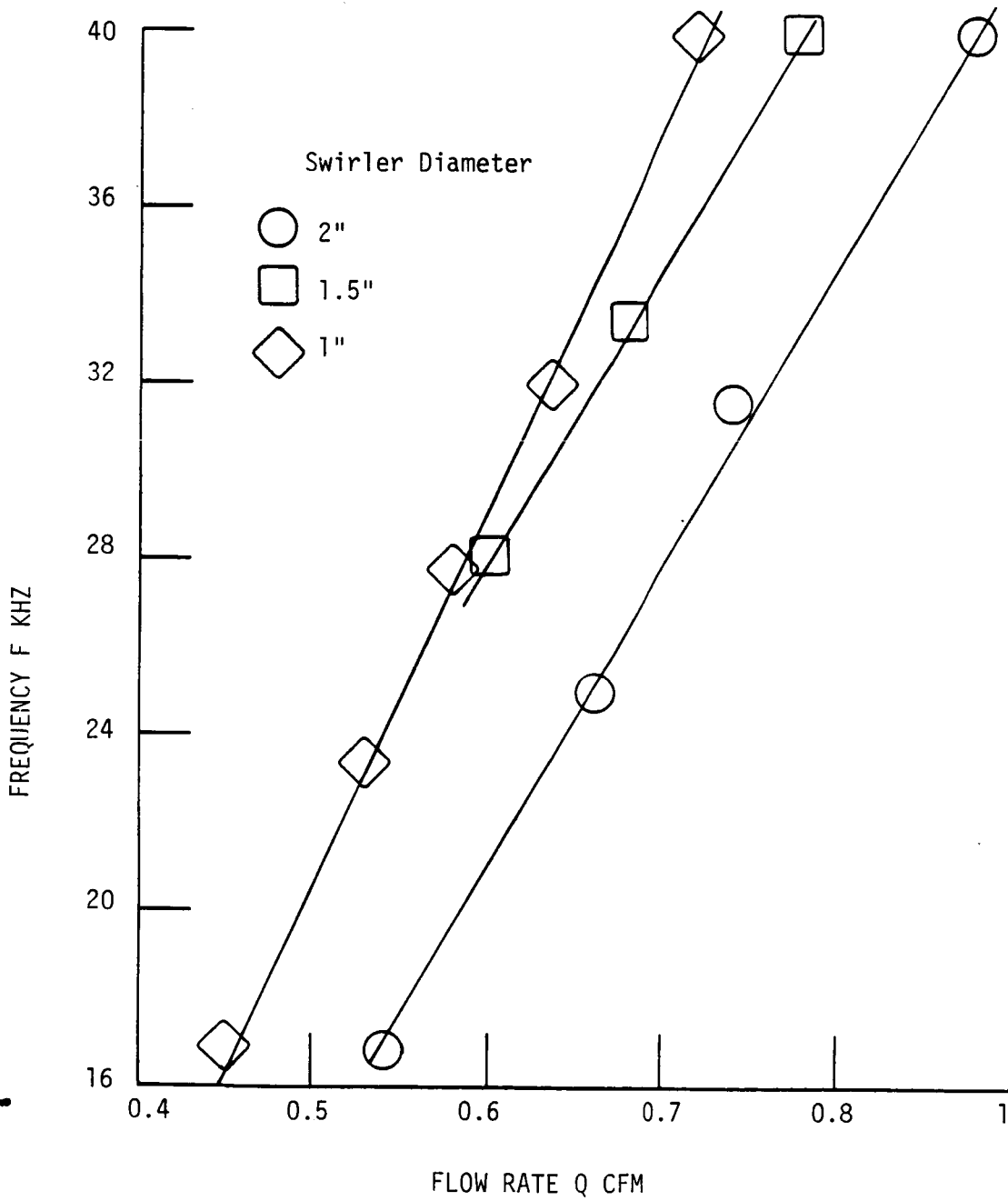

Figure 17. Flow rate vs. frequency for sensor 9 with three swirlers having various diameters.

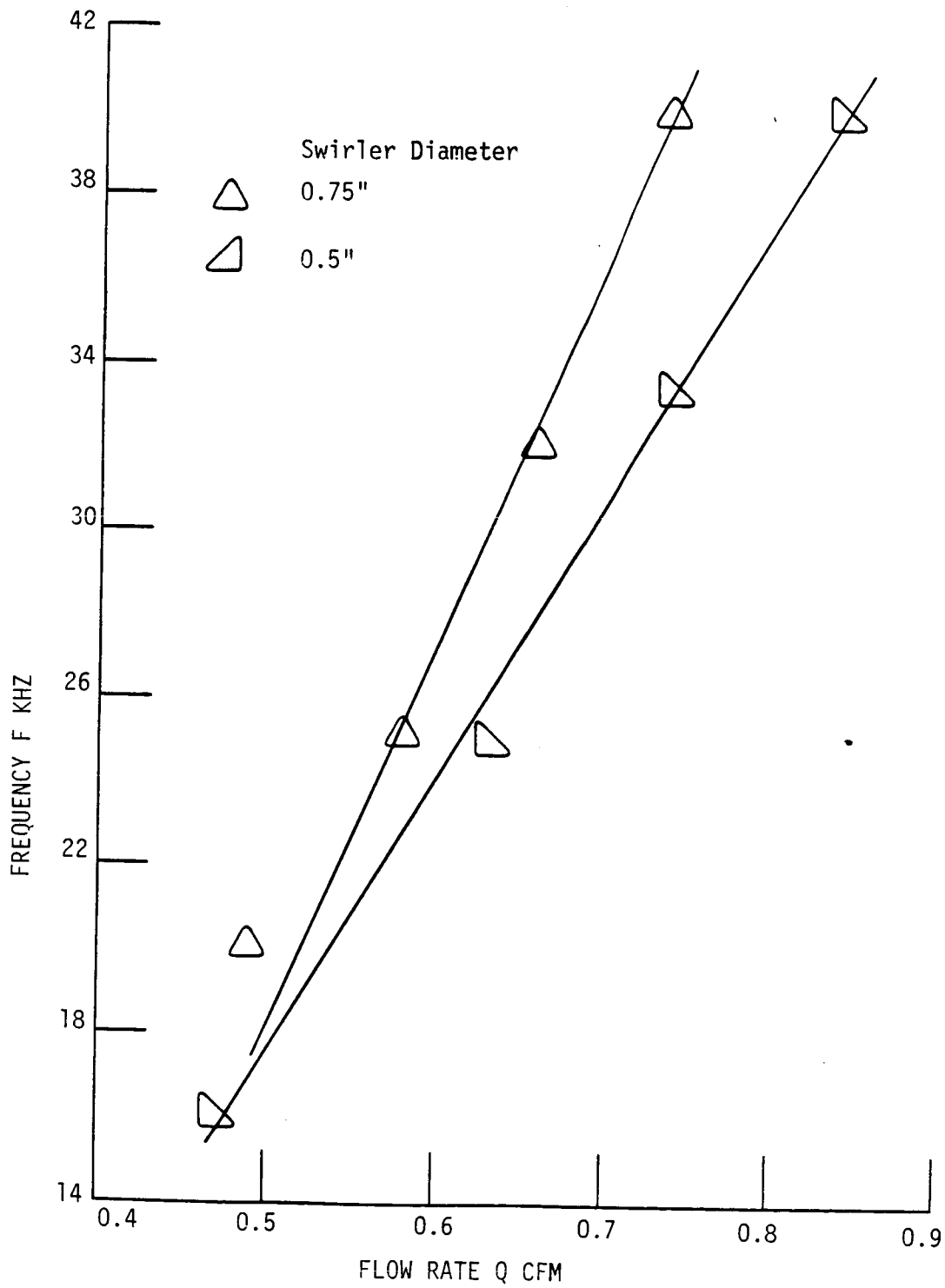

Figure 18. Flow rate vs. frequency for sensor 9 with two swirlers having various diameters.

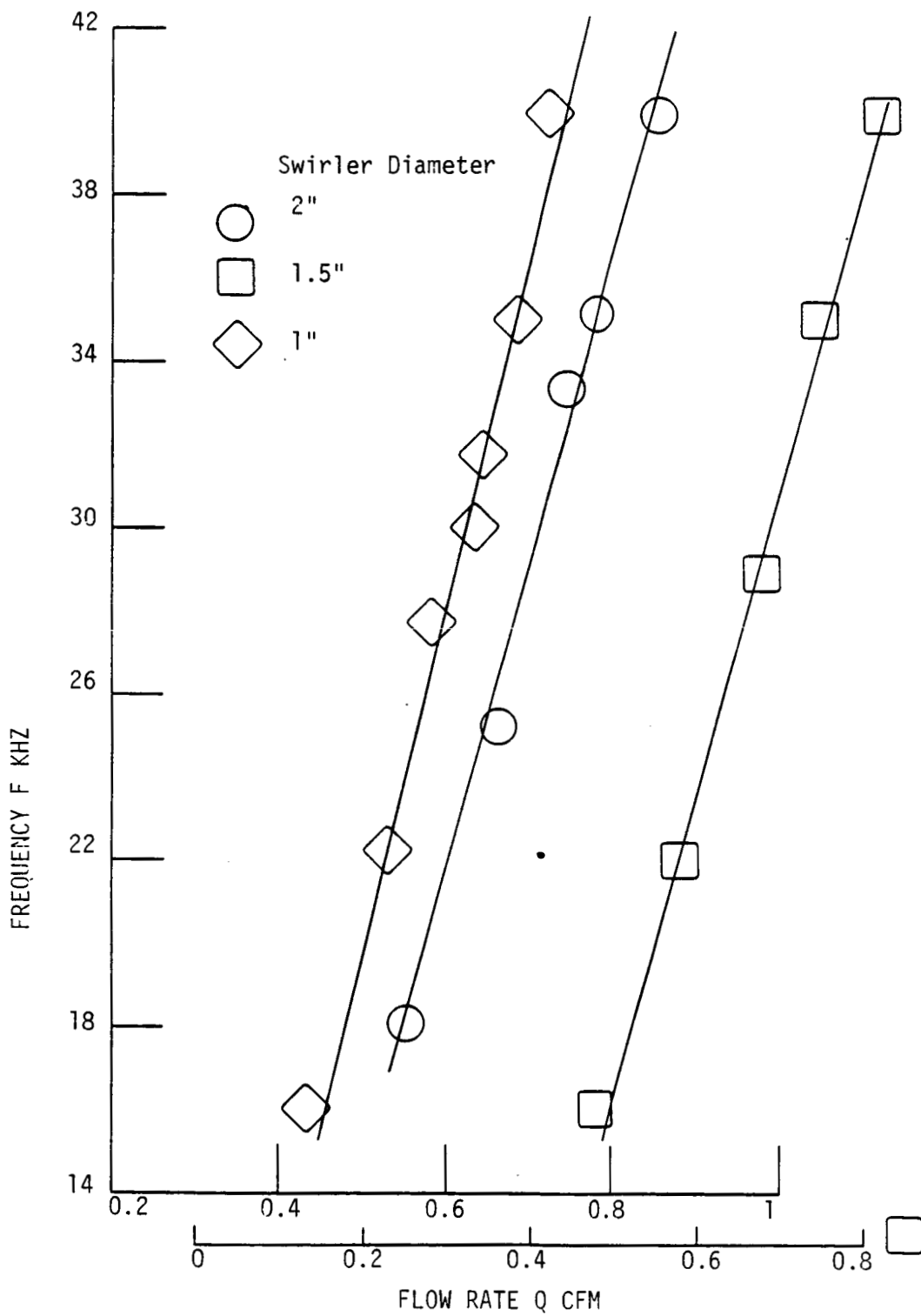

Figure 19. Flow rate vs. frequency for sensor 10 with three swirlers having various diameters.

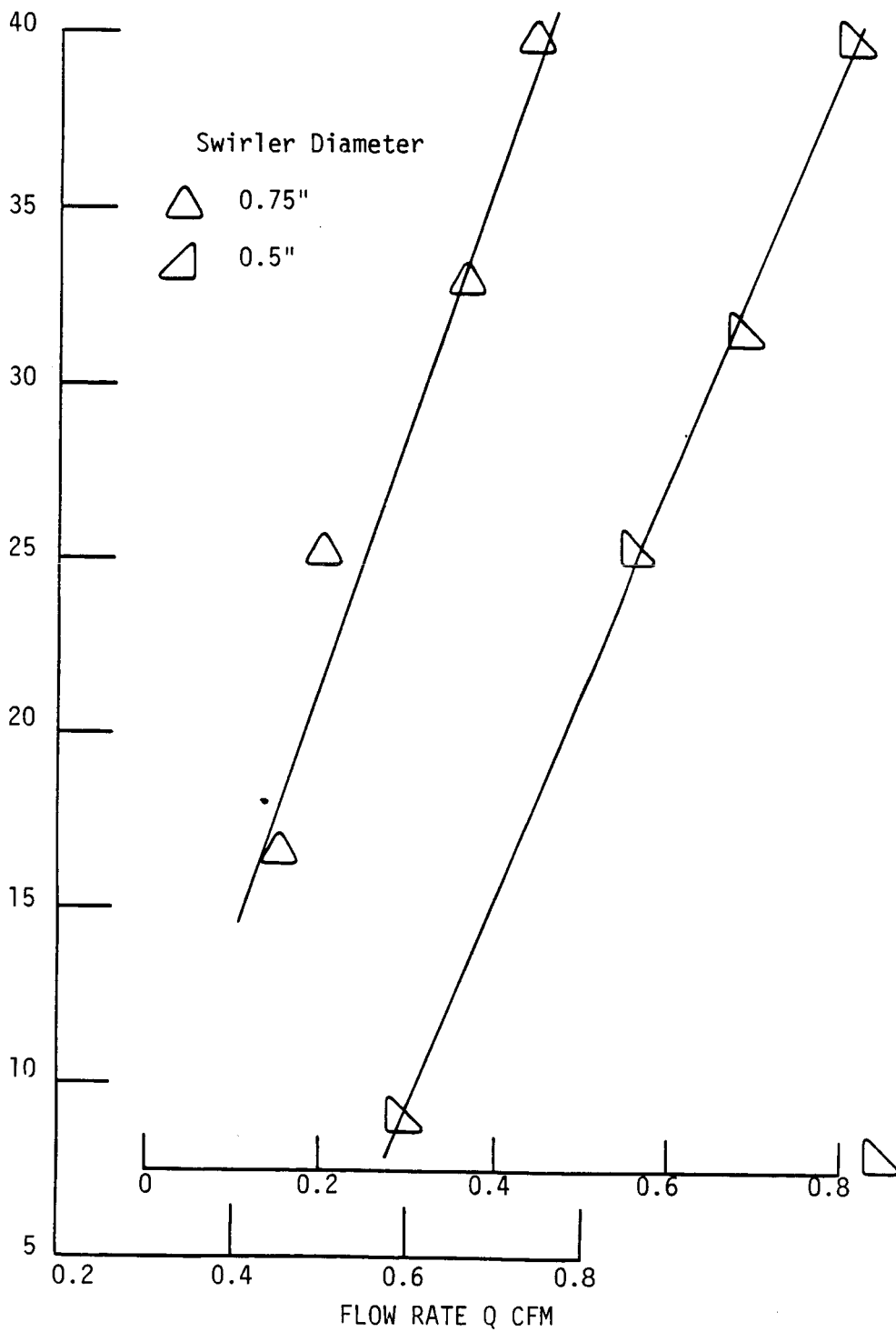

Figure 20. Flow rate vs. frequency for sensor 10 with two swirlers having various diameters.

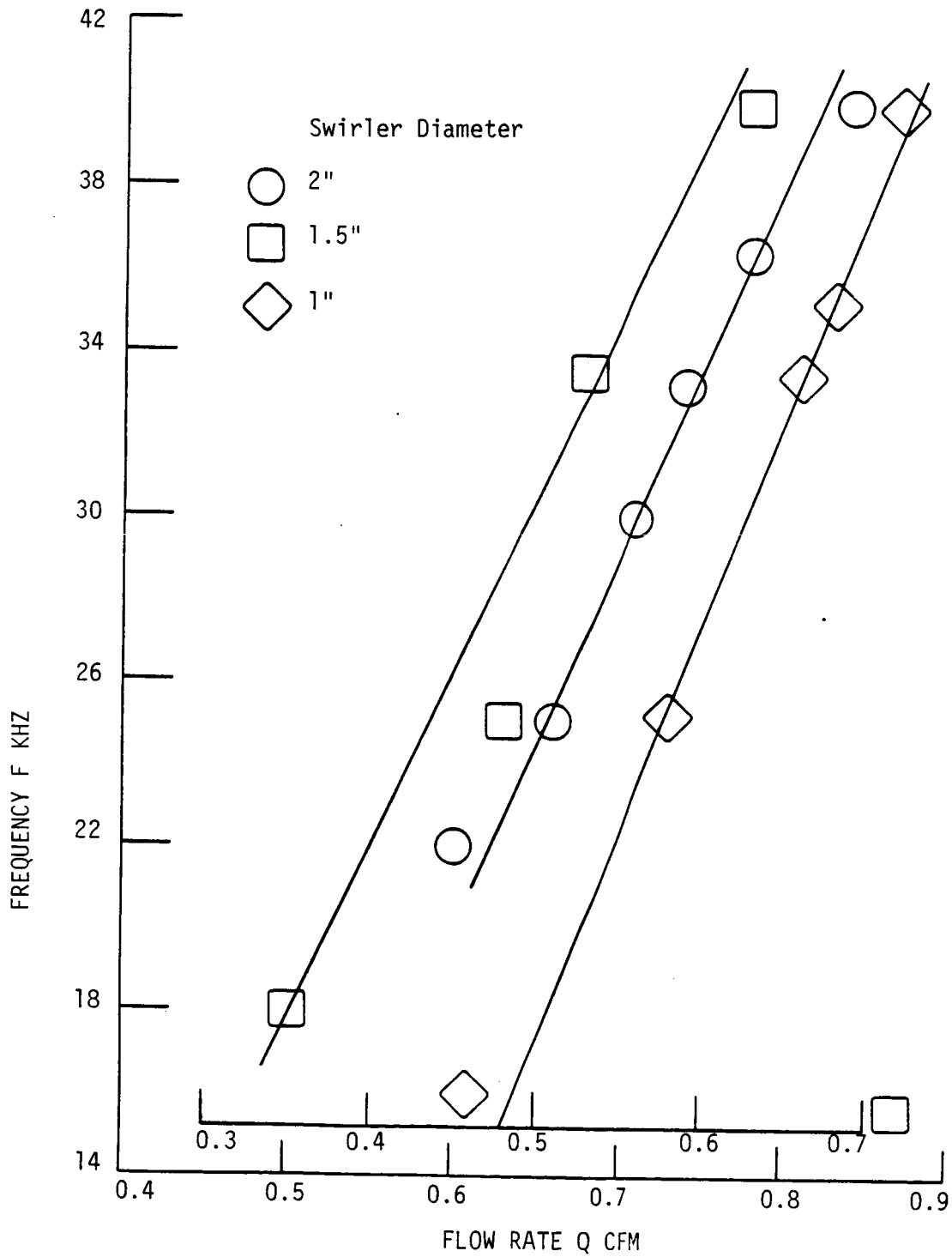

Figure 21. Flow rate vs. frequency for sensor 11 with three swirlers having various diameters.

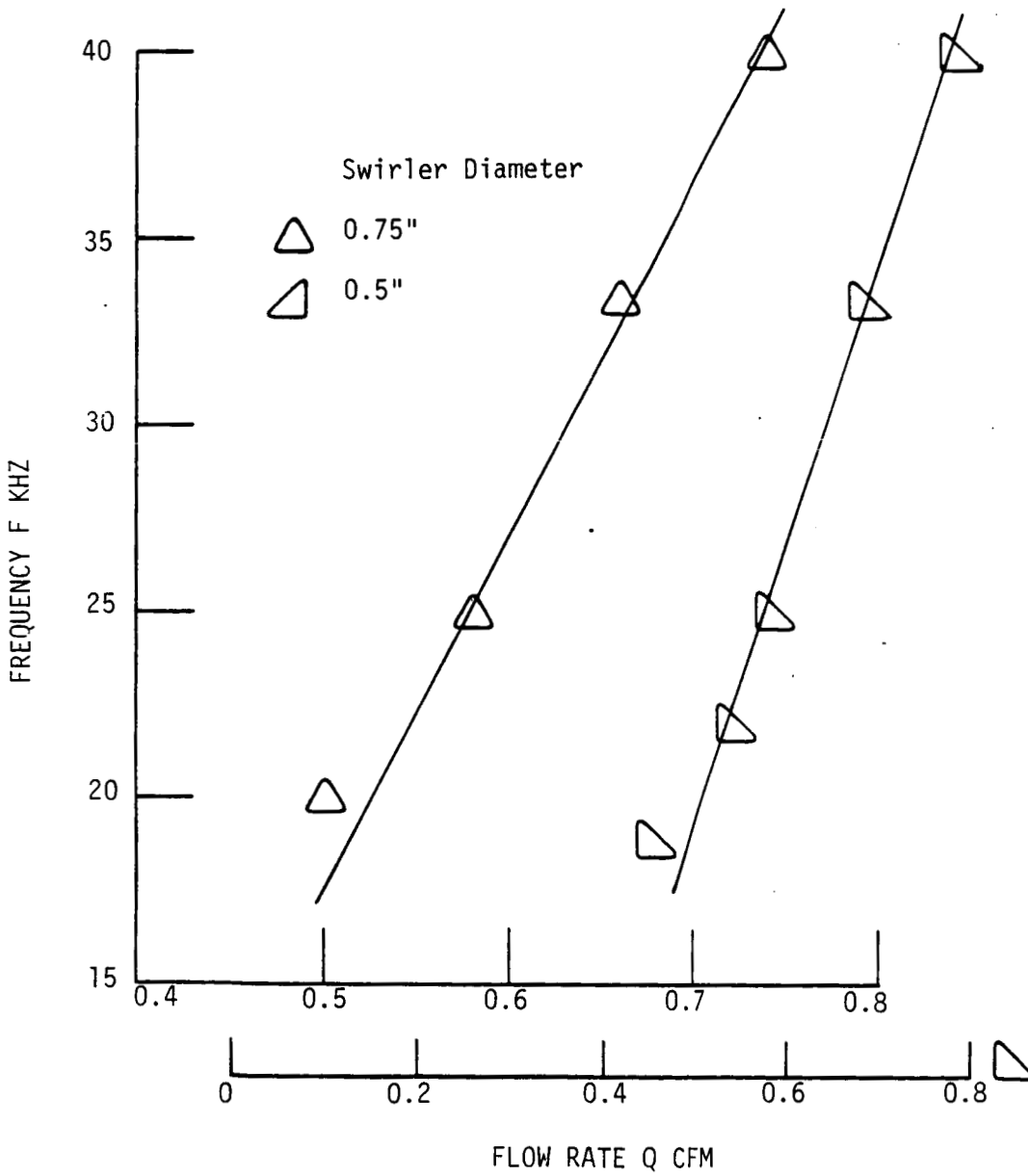

Figure 22. Flow rate vs. frequency for sensor 4 with two swirlers having various diameters.

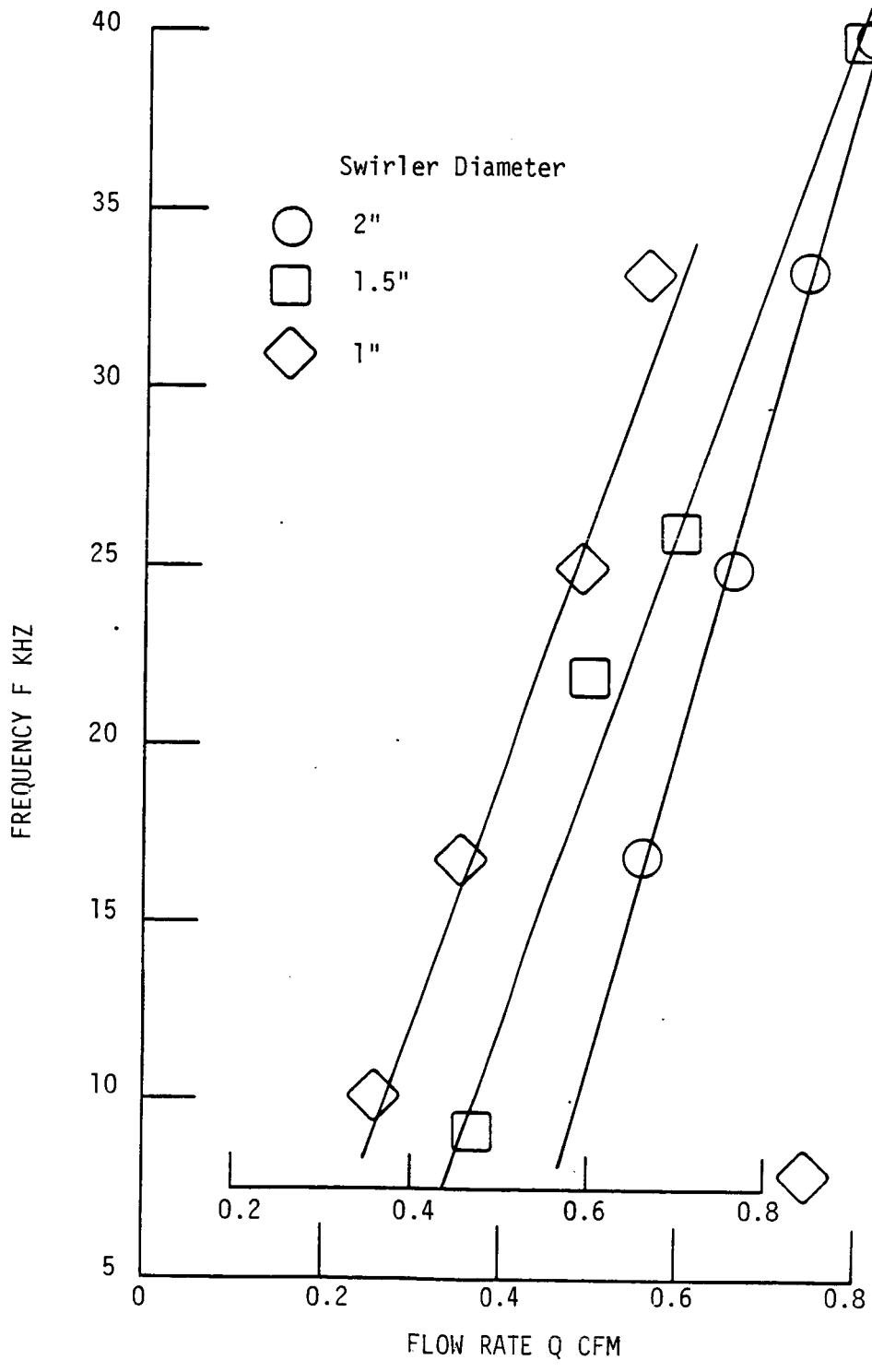

Figure 23. Flow rate vs. frequency for sensor 12 with three swirlers having various diameters.

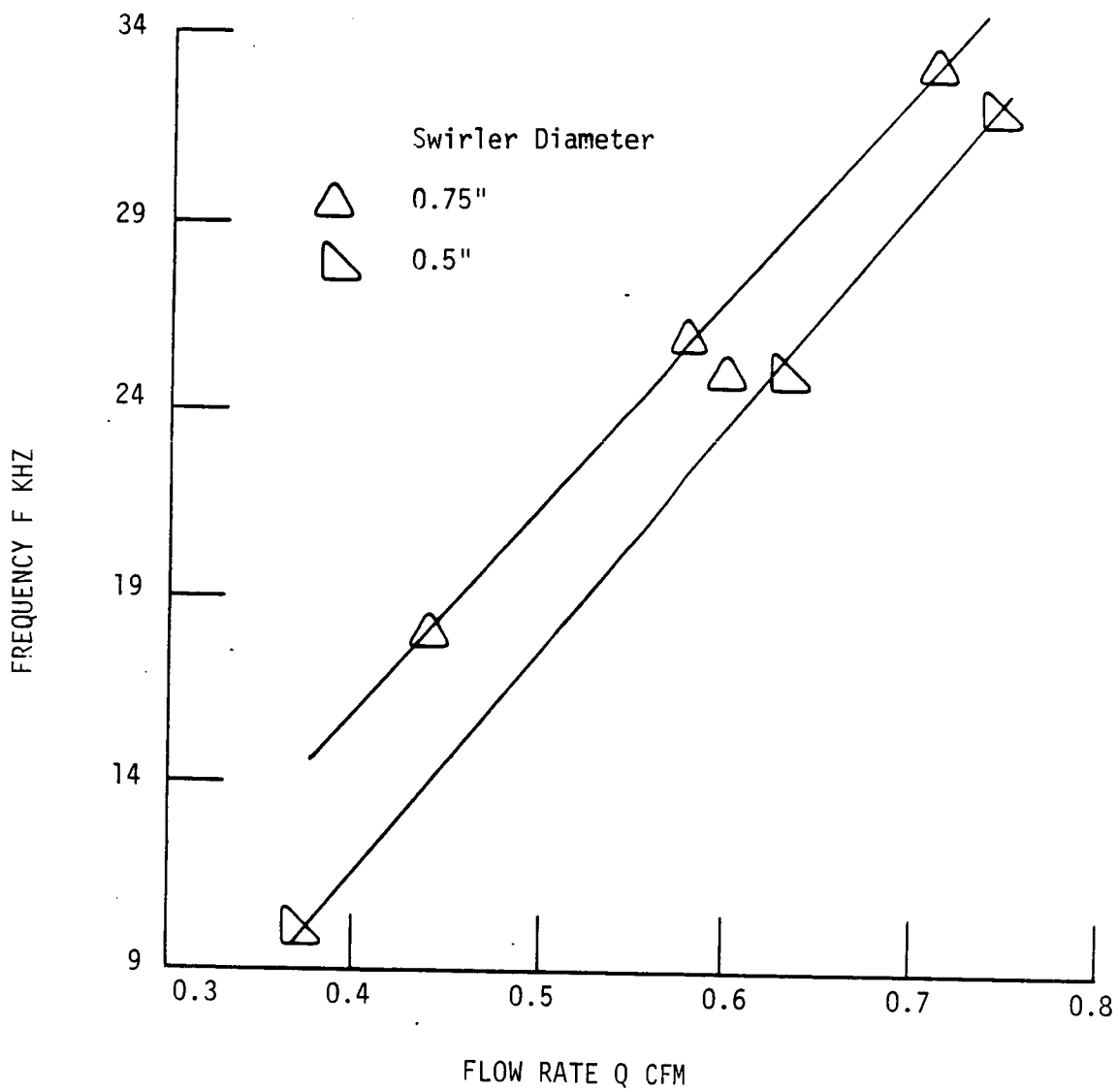

Figure 24. Flow rate vs. frequency for sensor 12 with two swirlers having various diameters.

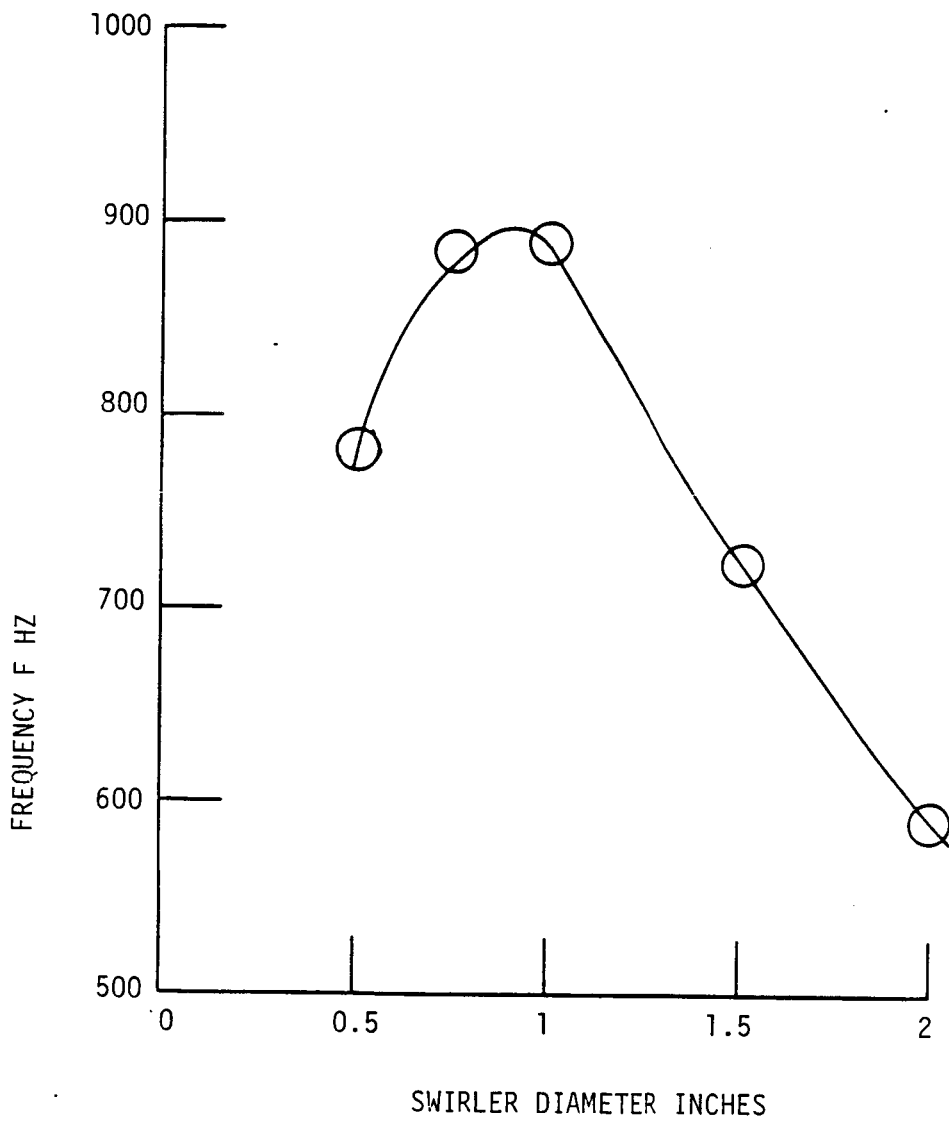

Figure 25. Effect of various swirler diameters on the frequency, sensor 1.

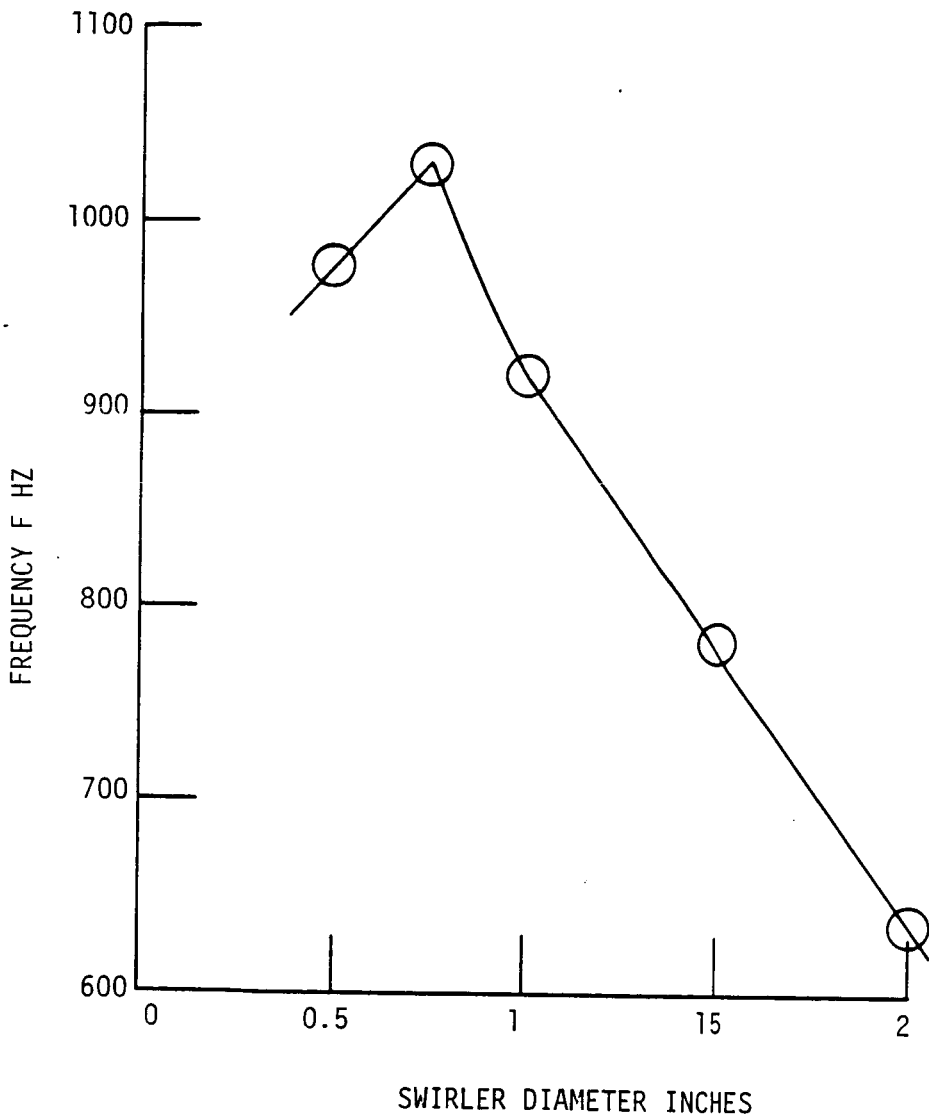

Figure 26. Effect of various swirler diameters on the frequency, sensor 2.

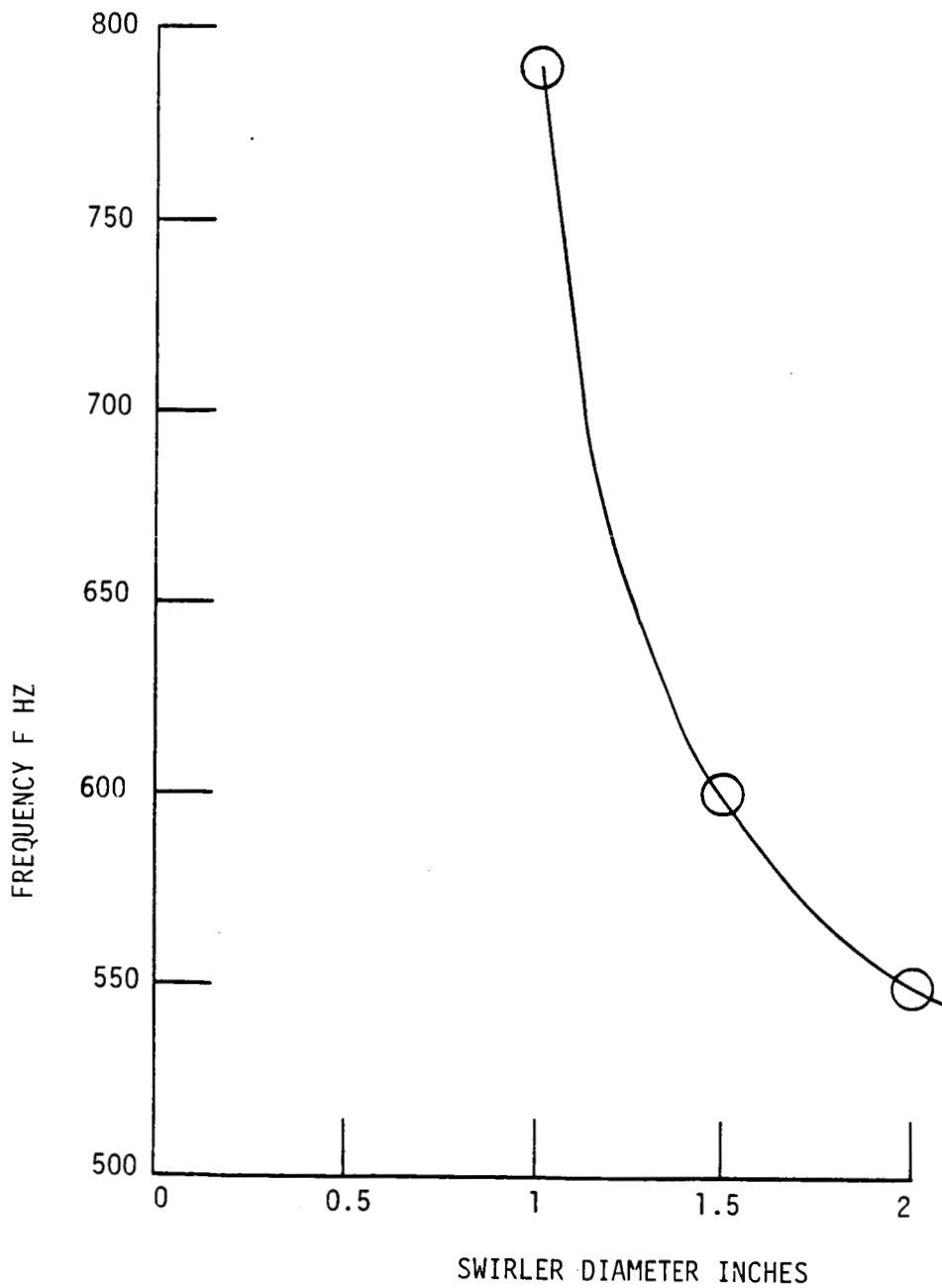

Figure 27. Effect of various swirler diameters on the frequency, sensor 3.

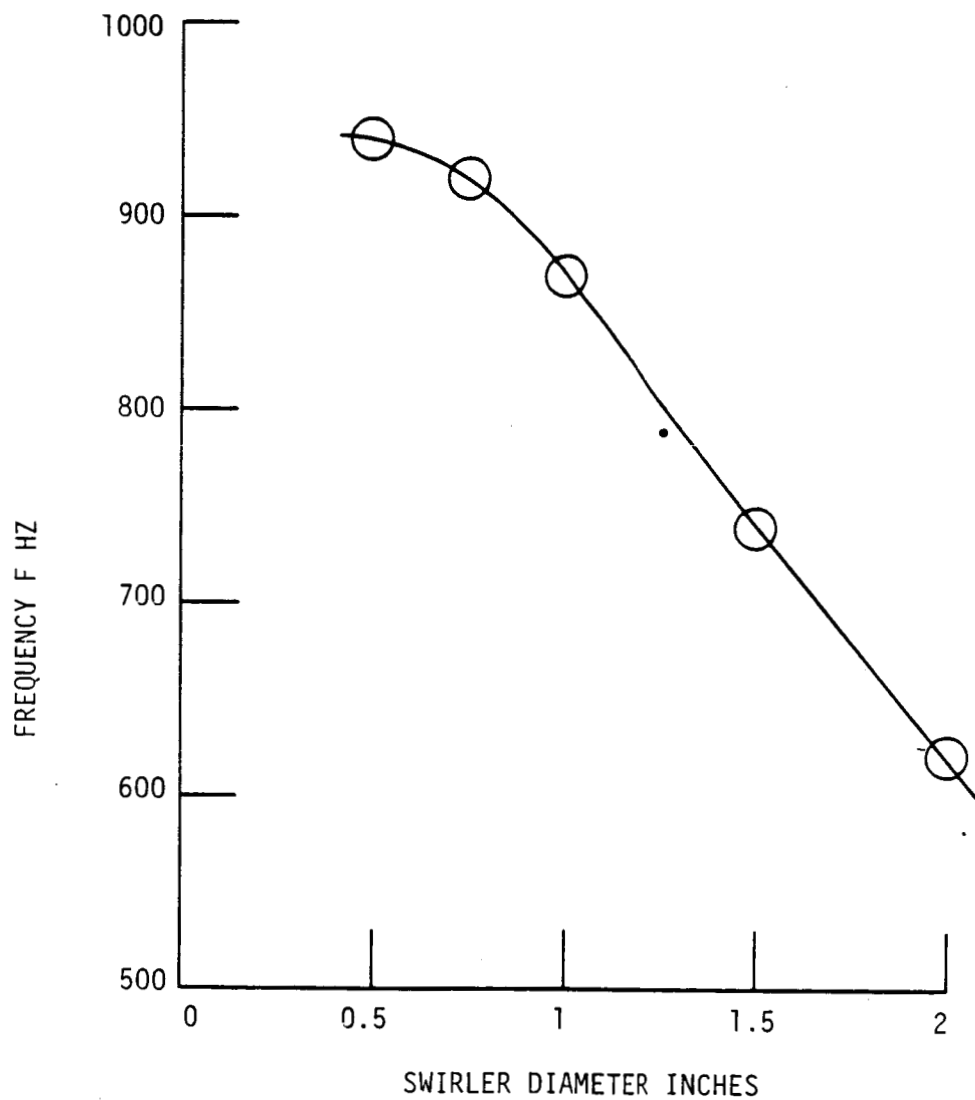

Figure 28. Effect of various swirler diameters on the frequency, sensor 4.

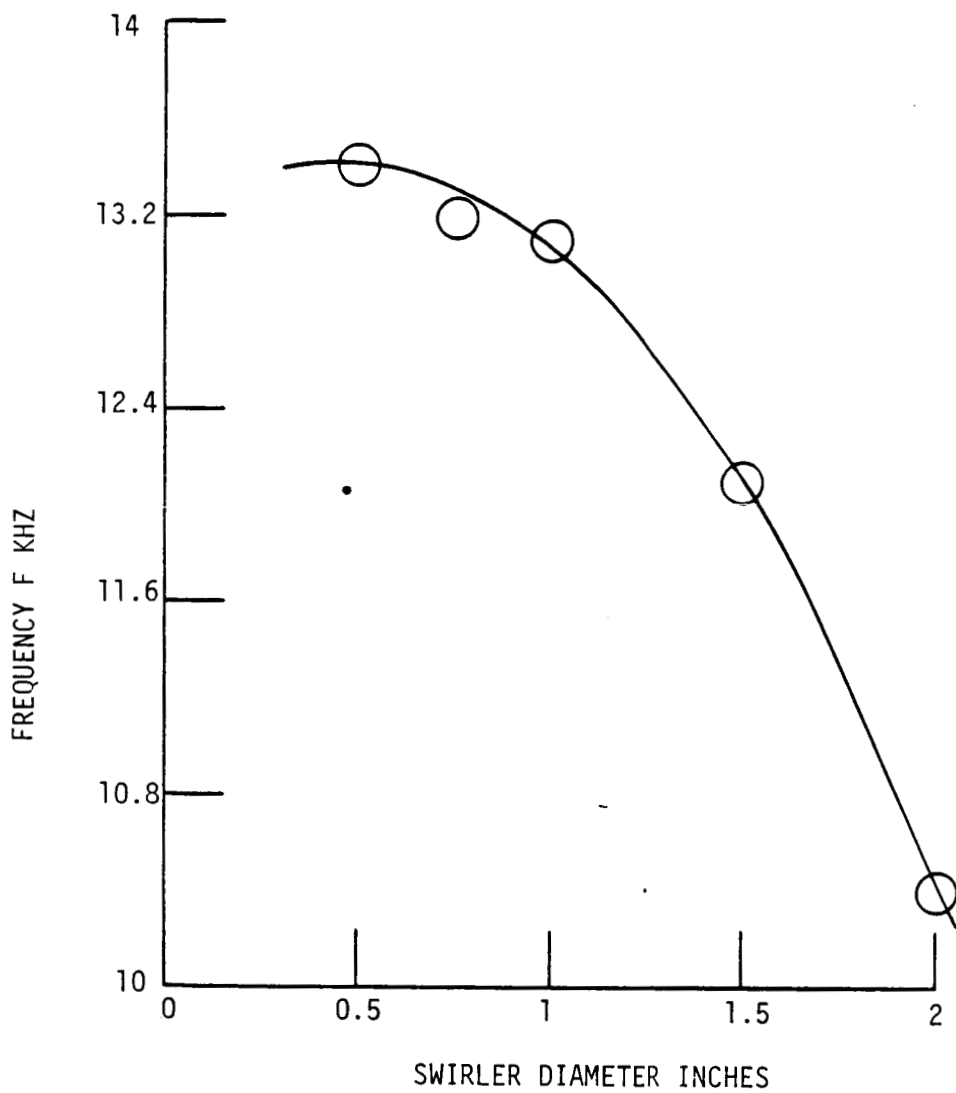

Figure 29. Effect of various swirler diameters on the frequency, sensor 5.

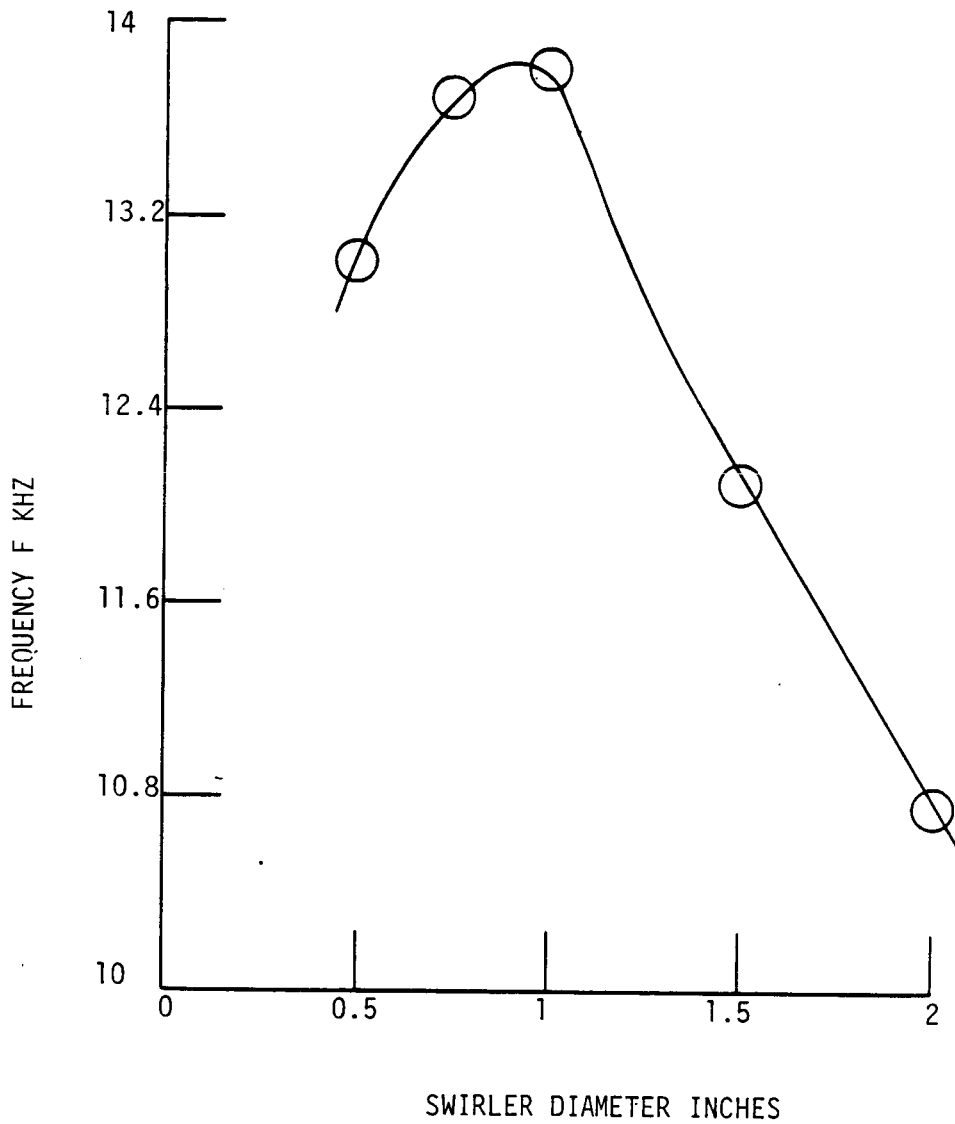

Figure 30. Effect of various swirler diameters on the frequency, sensor 6.

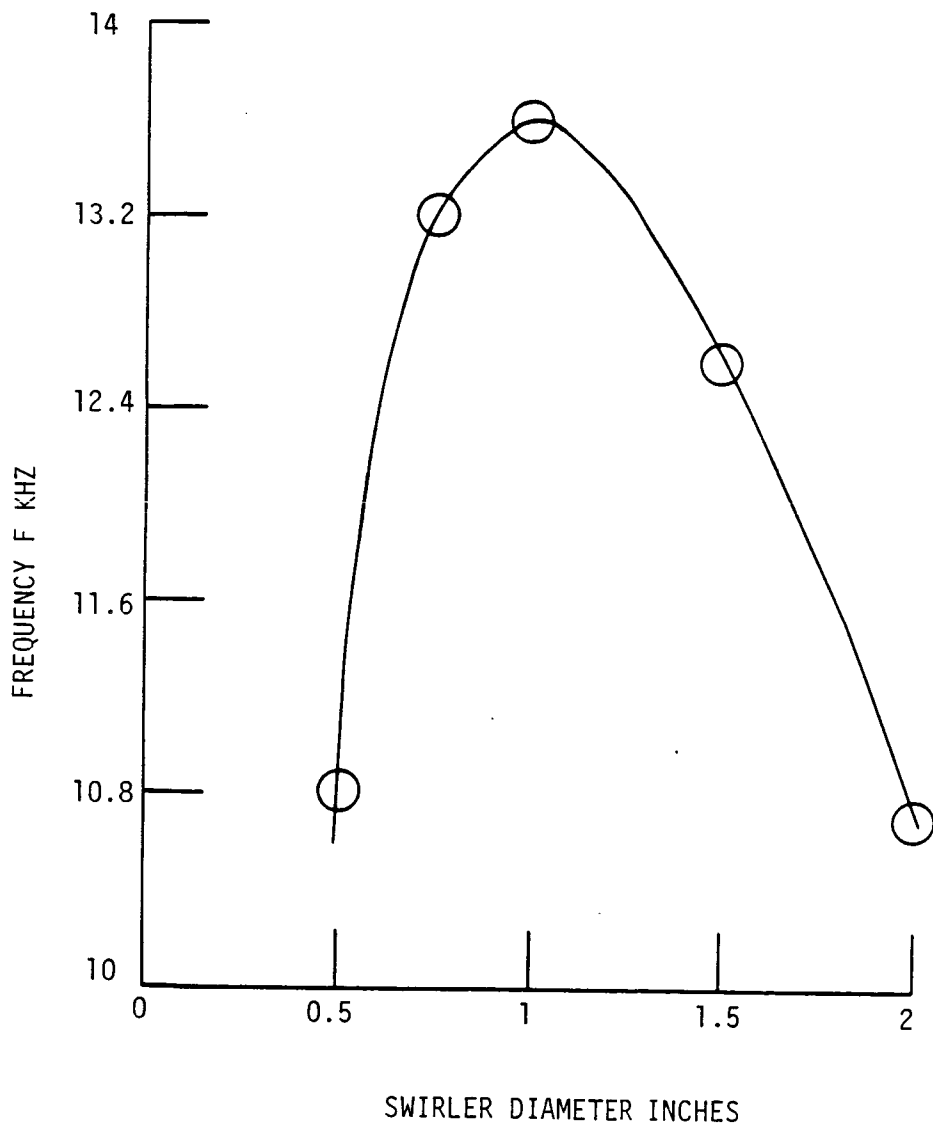

Figure 31. Effect of various swirler diameters on the frequency, sensor 7.

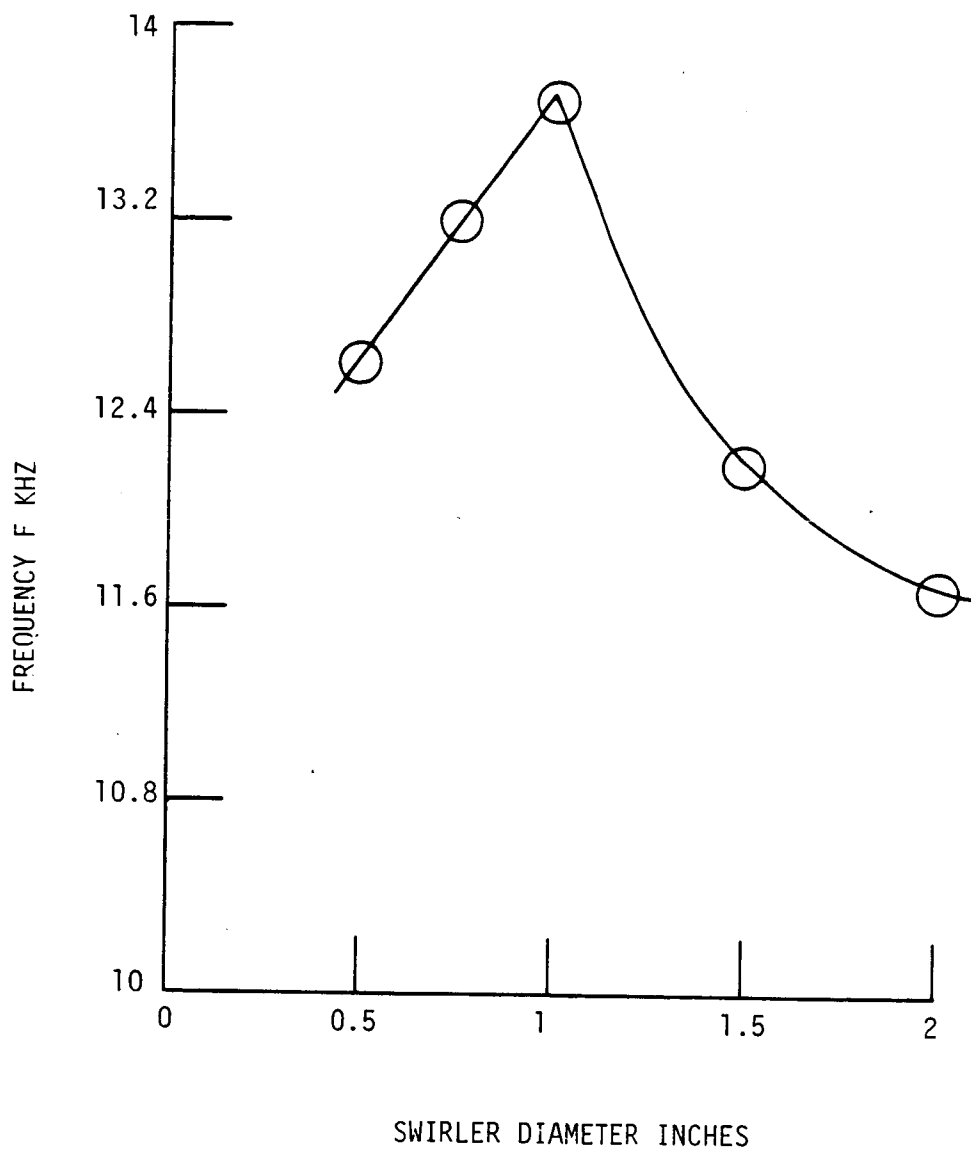

Figure 32. Effect of various swirler diameter on the frequency, sensor 8.

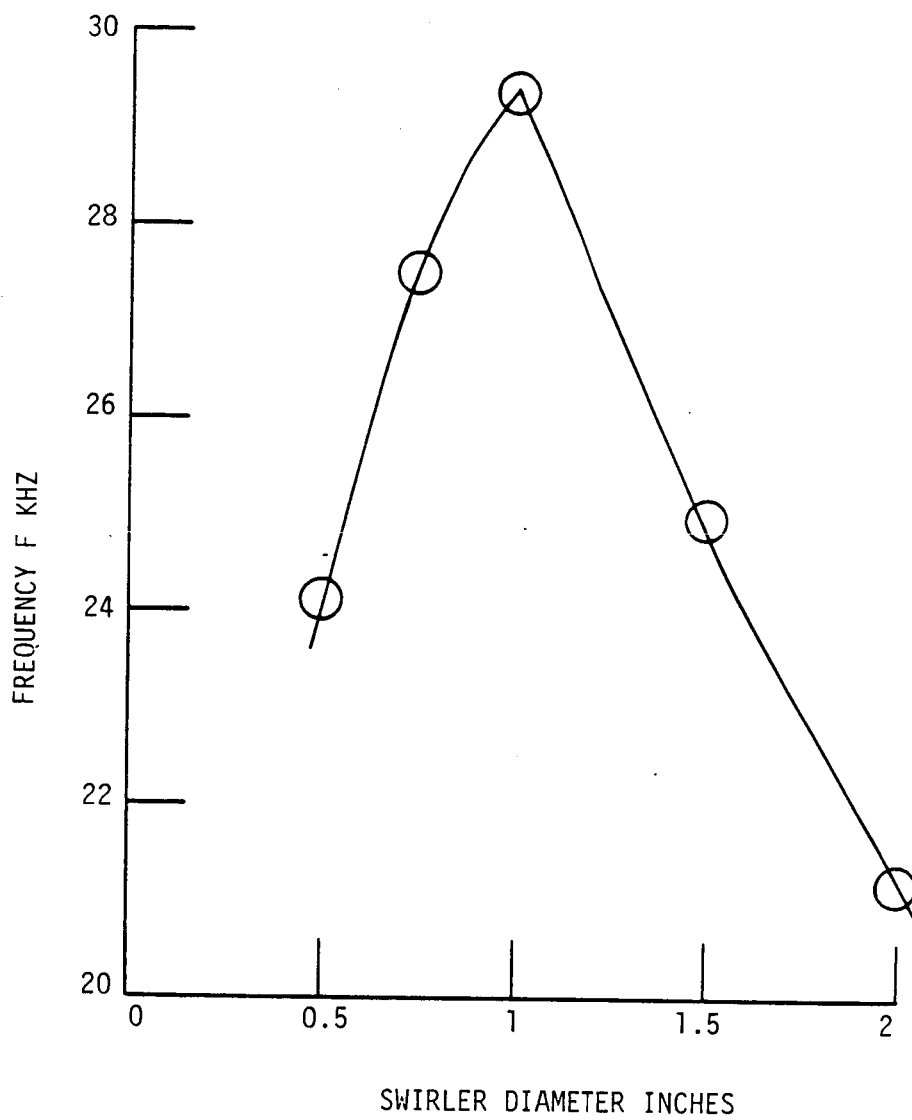

Figure 33. Effect of various swirler diameters on the frequency, sensor 9.

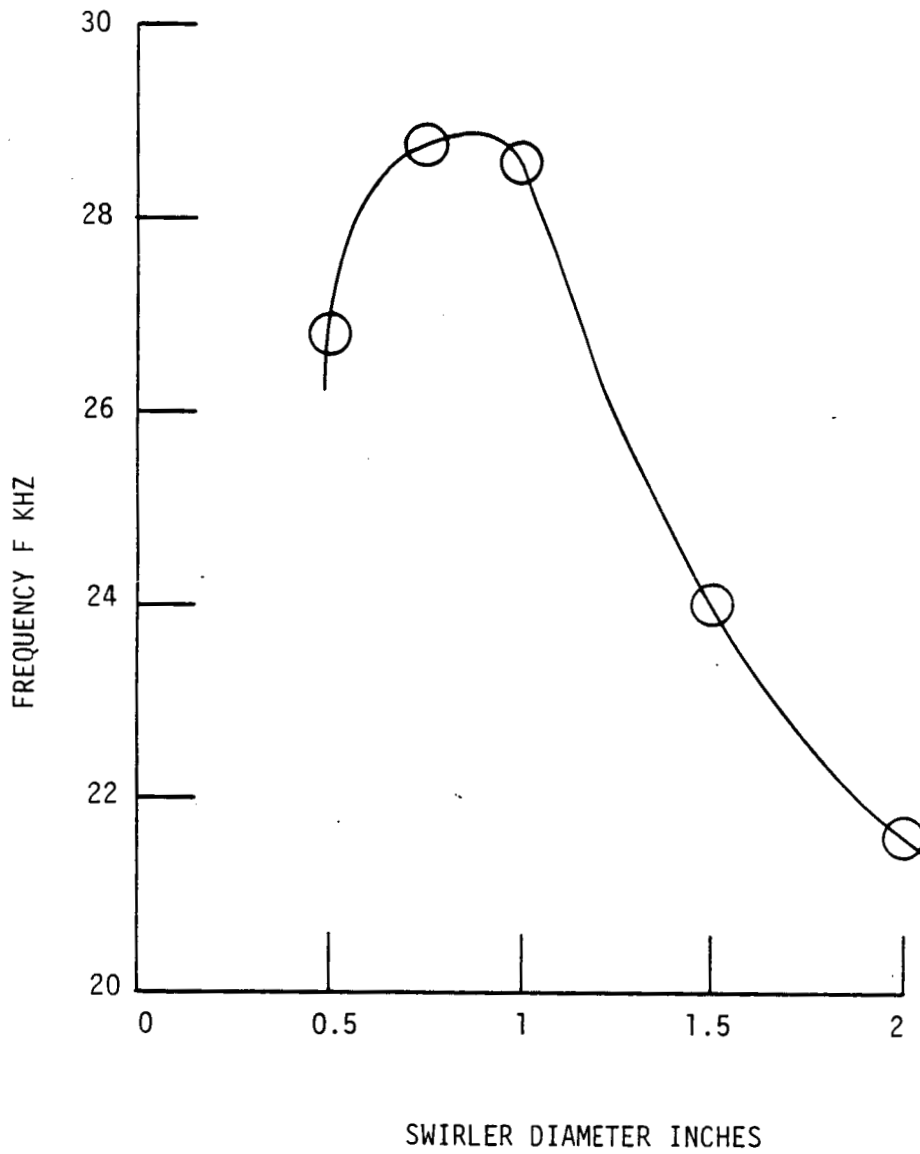

Figure 34. Effect of various swirler diameters on the frequency, sensor 10.

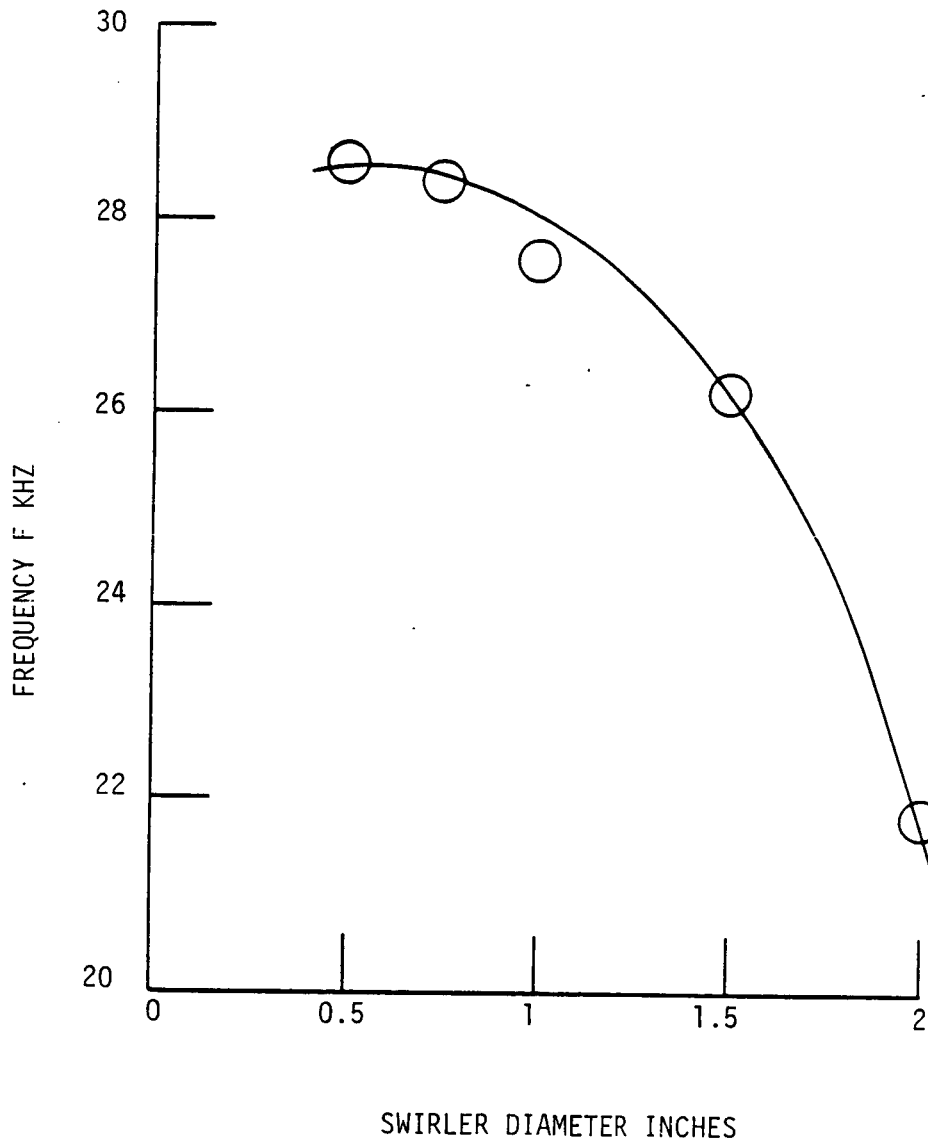

Figure 35. Effect of various swirler diameters on the frequency, sensor 11.

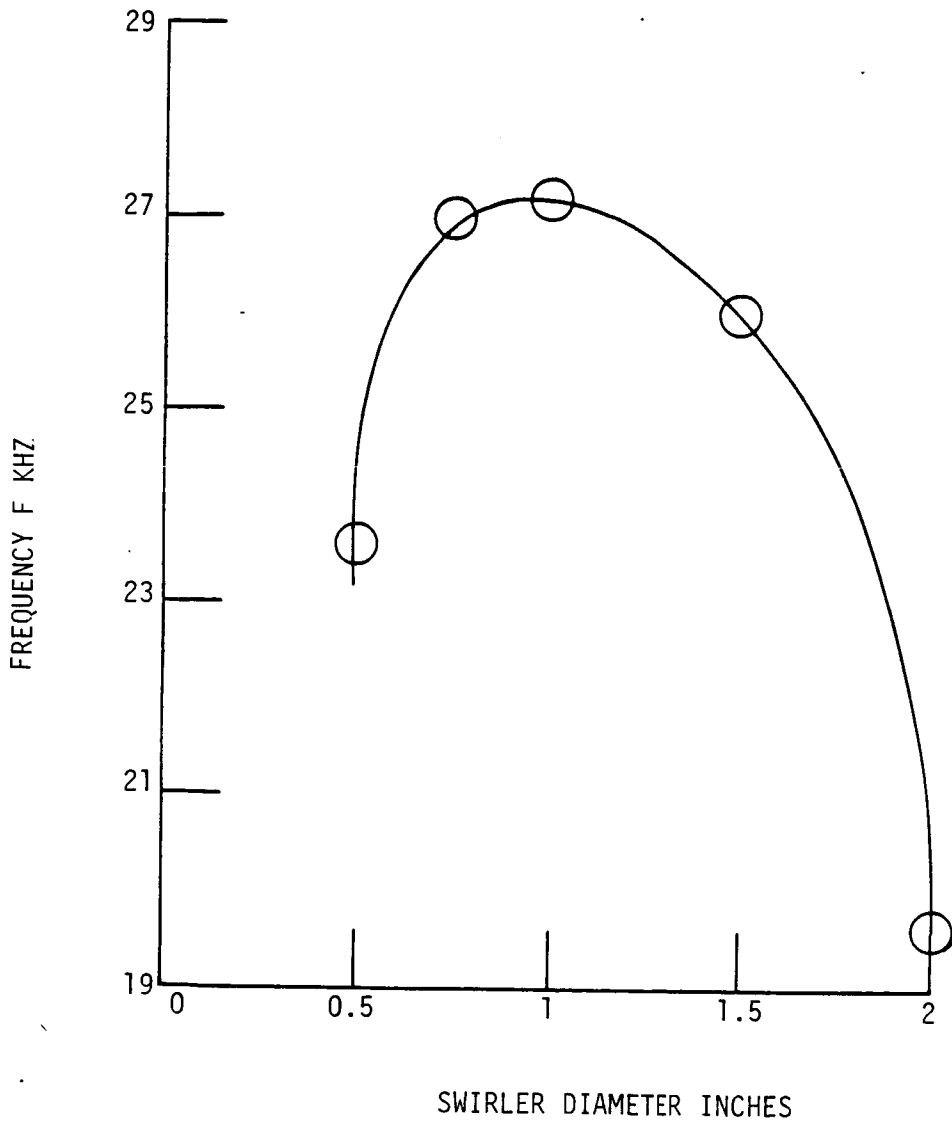

Figure 36. Effect of various swirler diameters on the frequency, sensor 12.

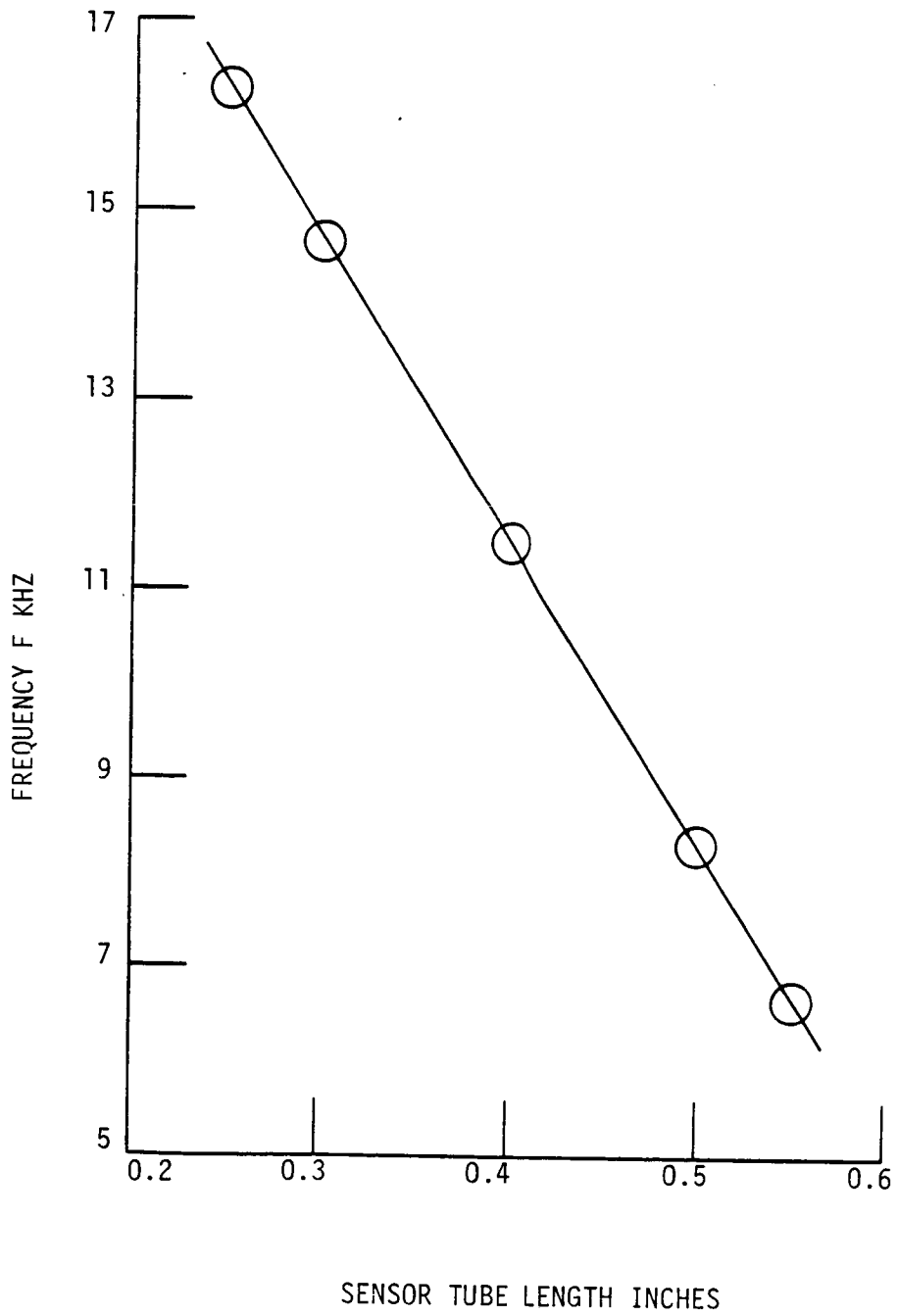

Figure 37. Effect of the sensor tube length on the frequency.

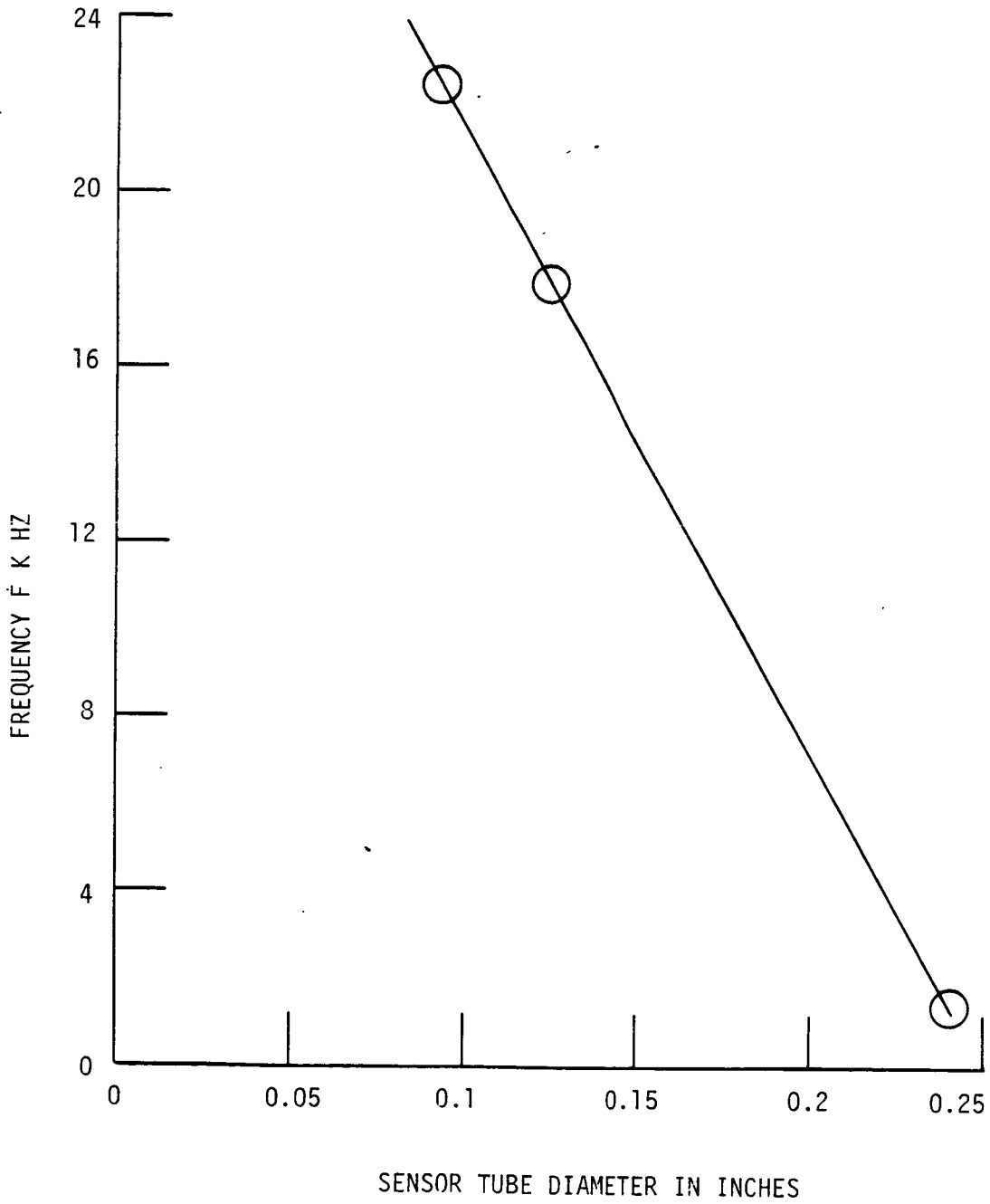

Figure 38. Effect of sensor tube diameter on the frequency.

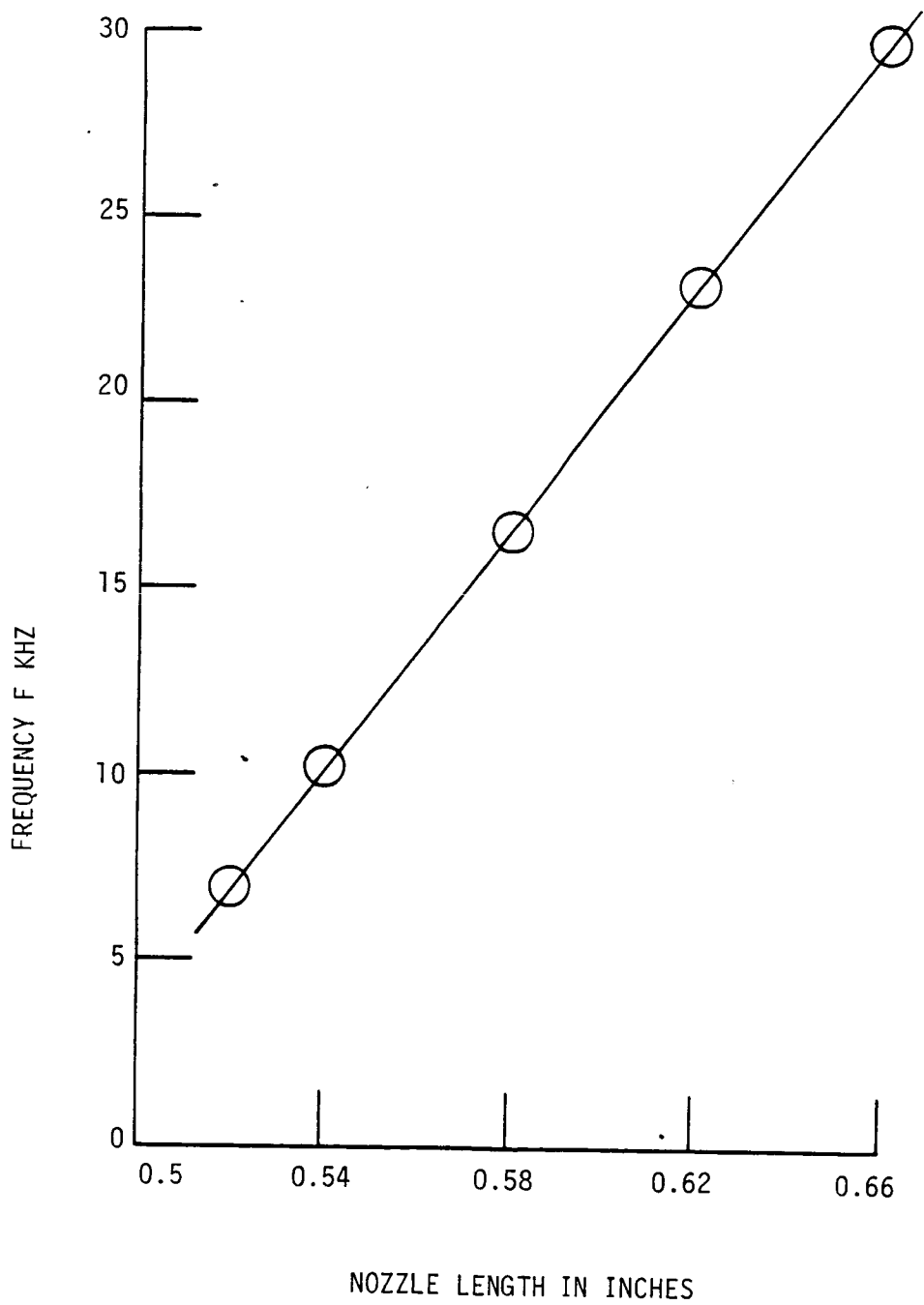

Figure 39. Effect of the nozzle length on the frequency.

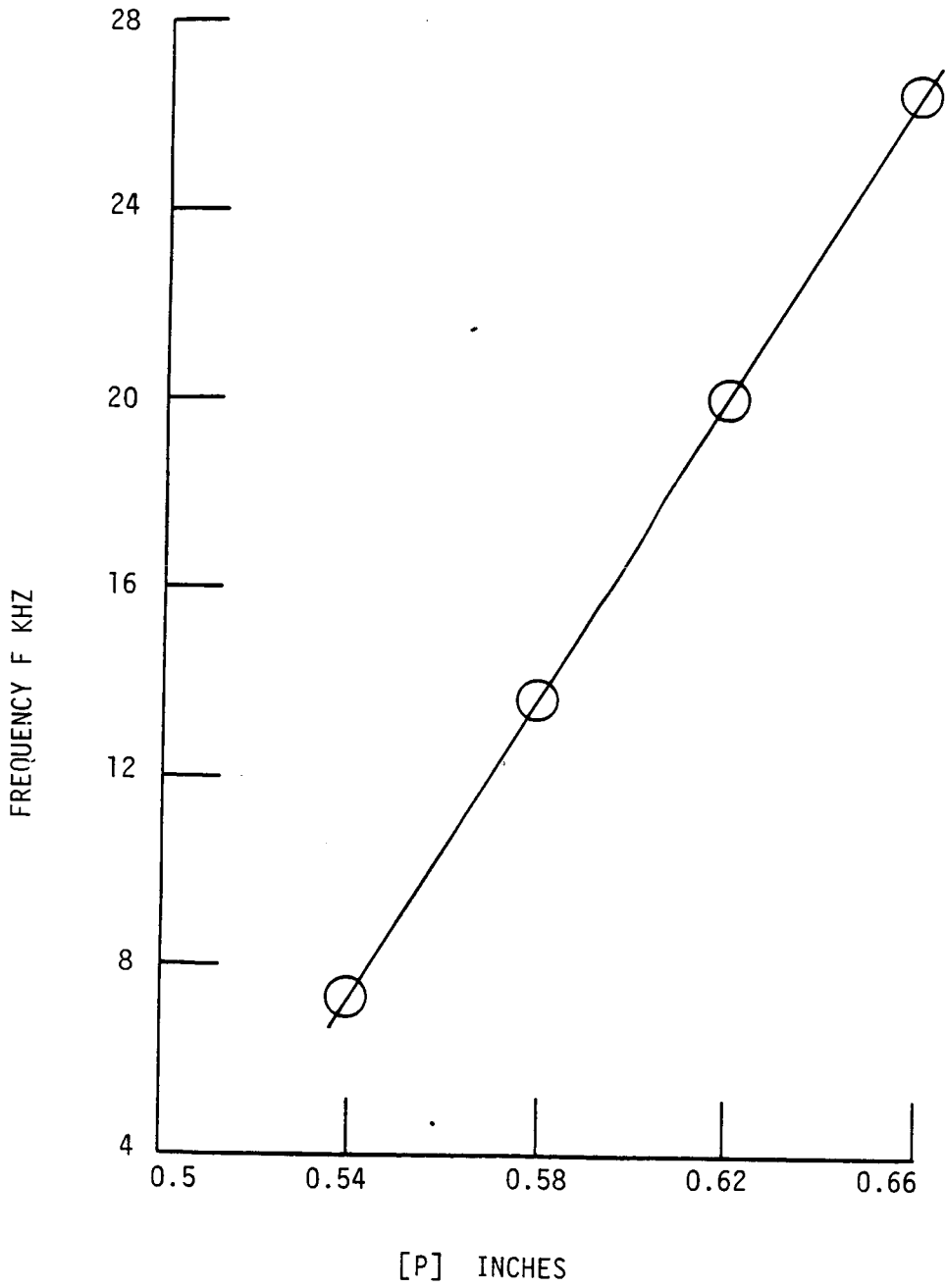

Figure 40. Effect of the (P) length on the frequency.

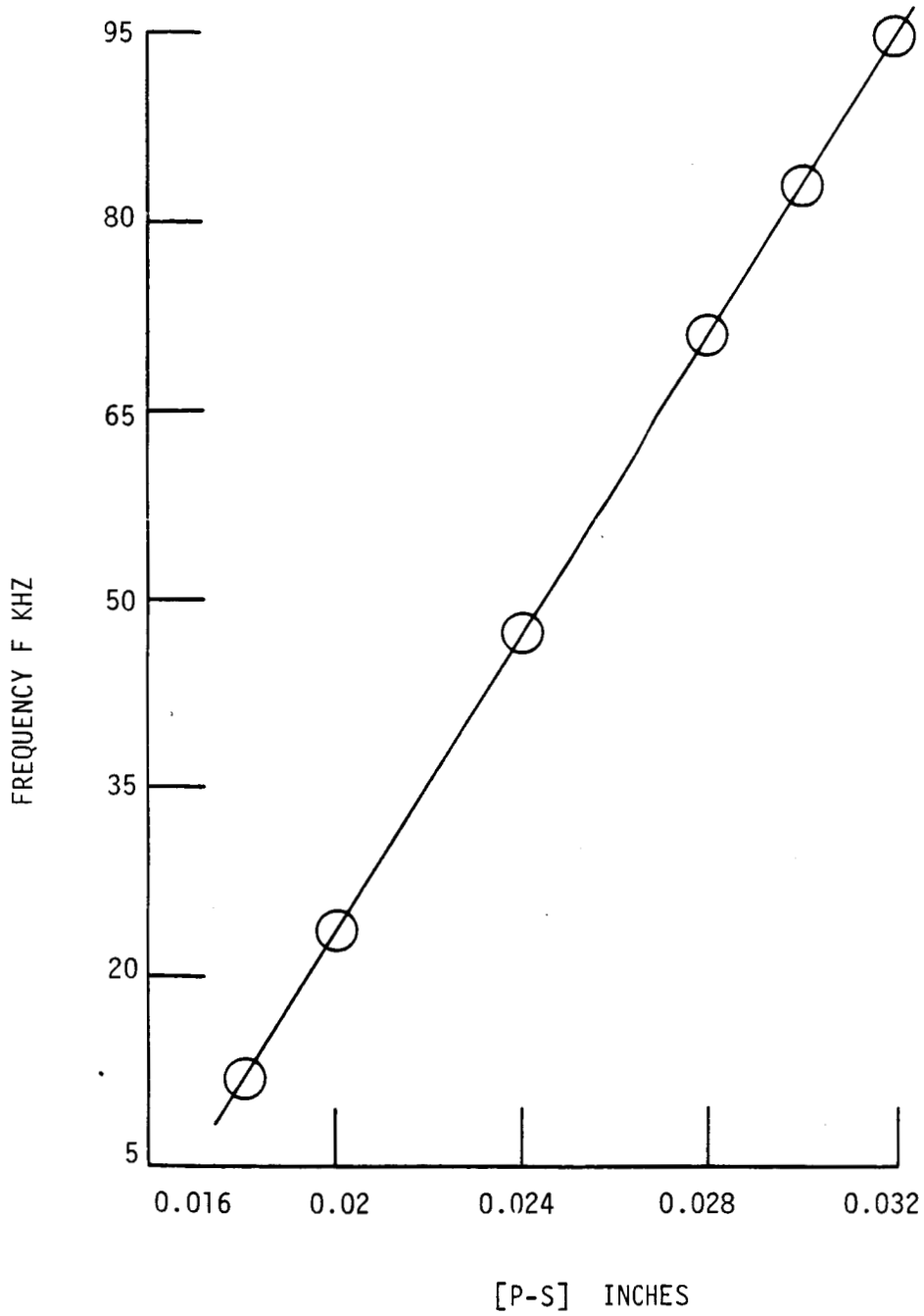

Figure 41. Effect of pick up signal point on frequency.

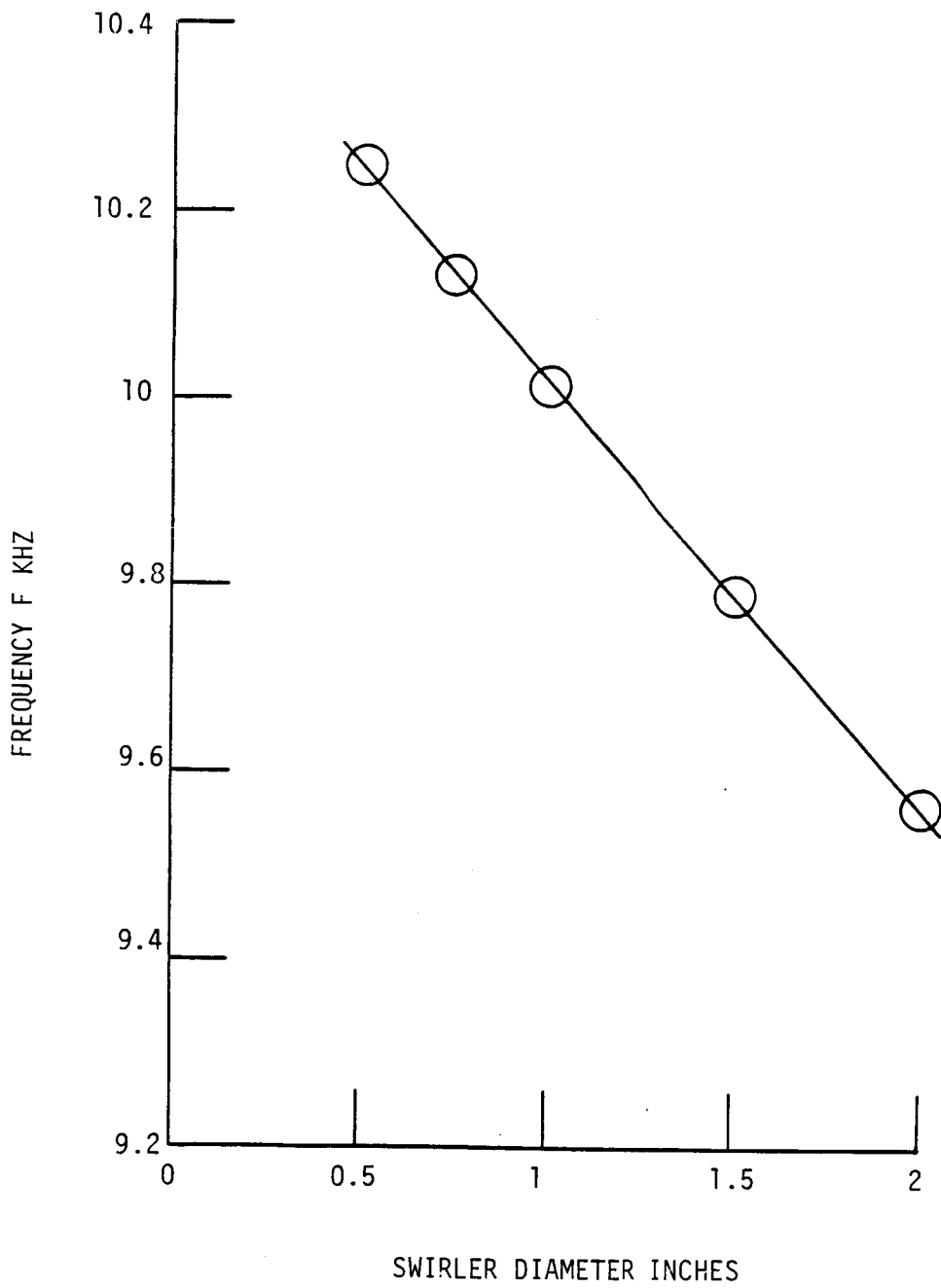

Figure 42. Effect of the swirler diameter on frequency.

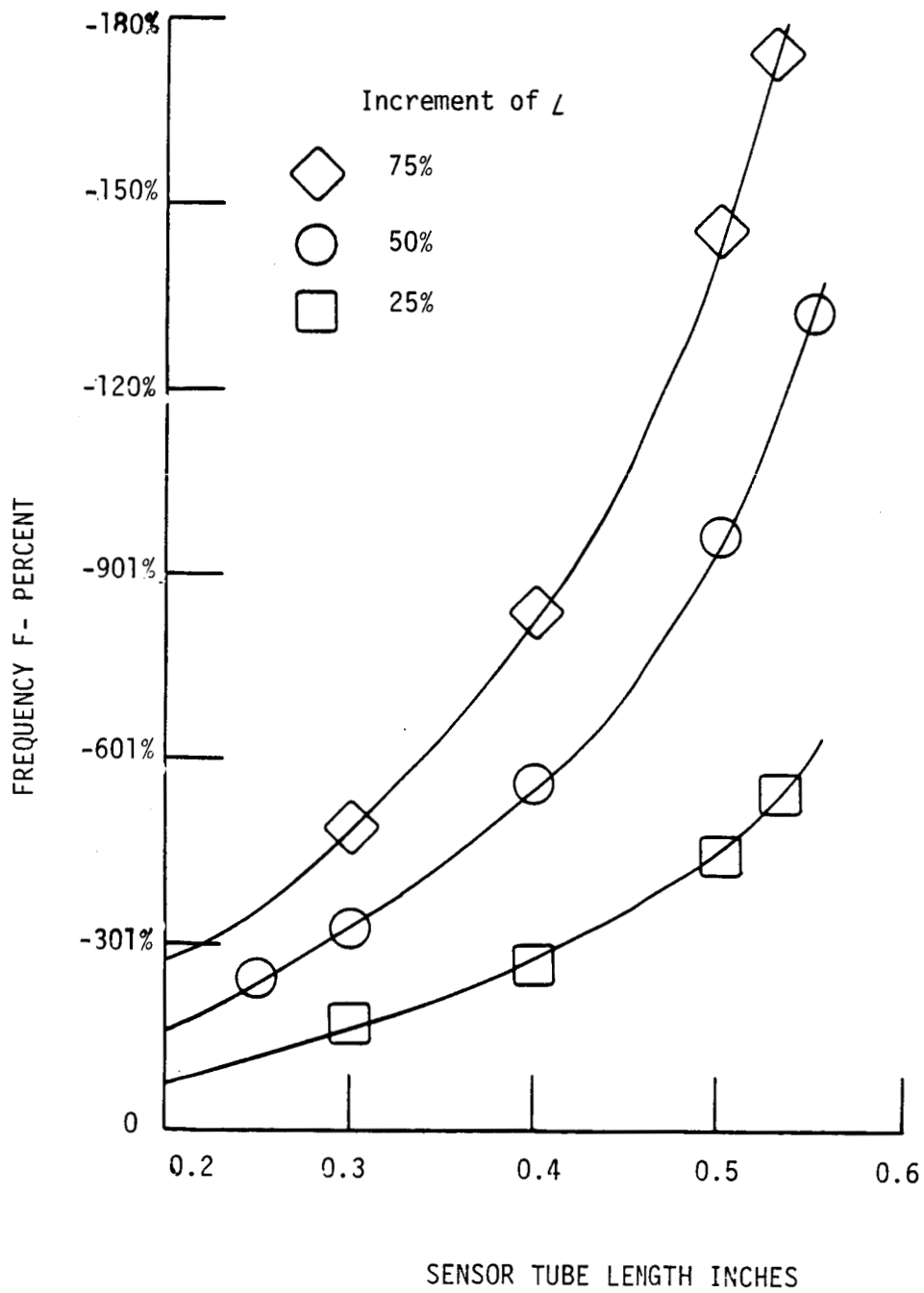

Figure 43. Effect of sensor tube length increase on frequency.

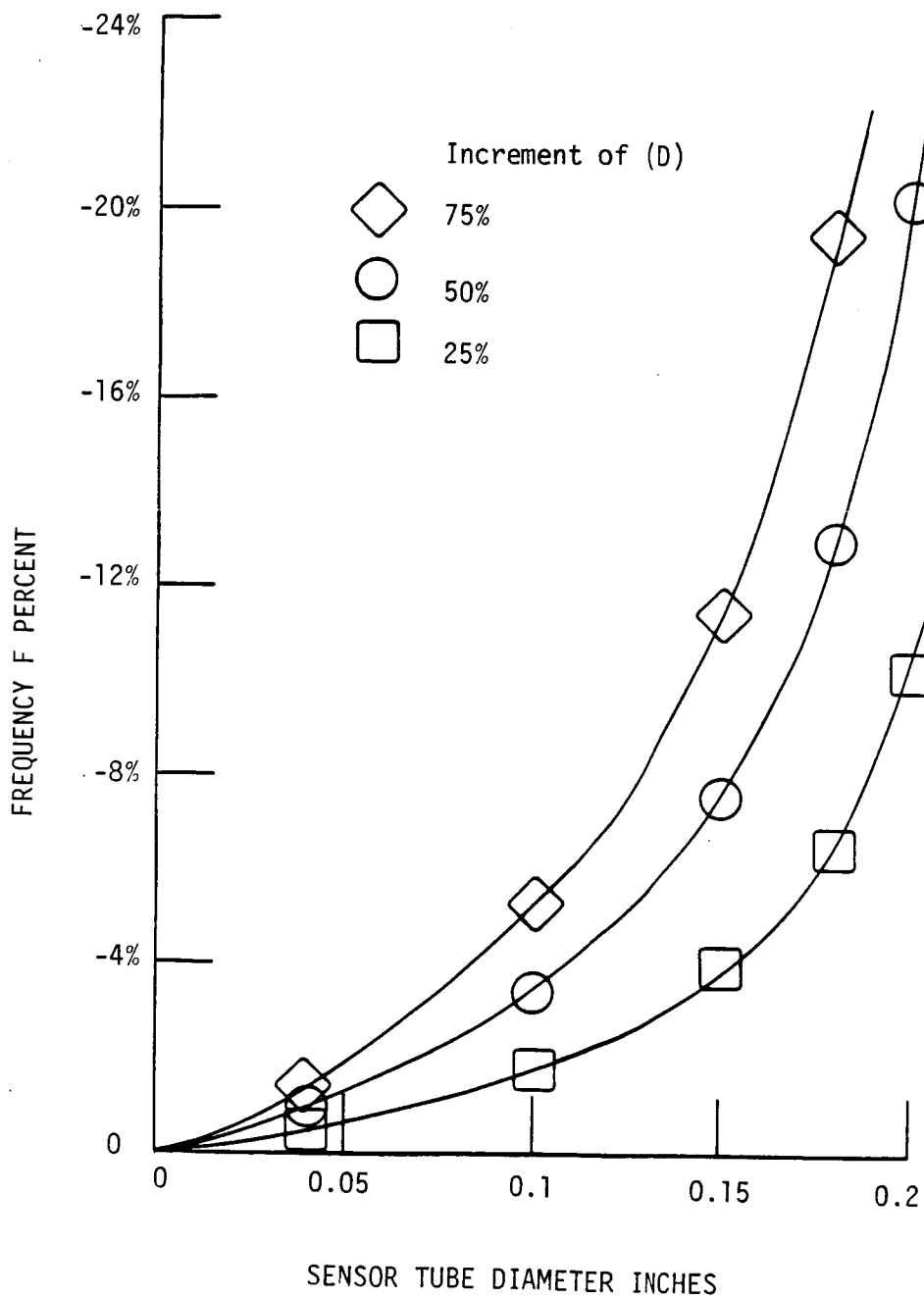

Figure 44. Effect of increase of sensor tube diameter on frequency.

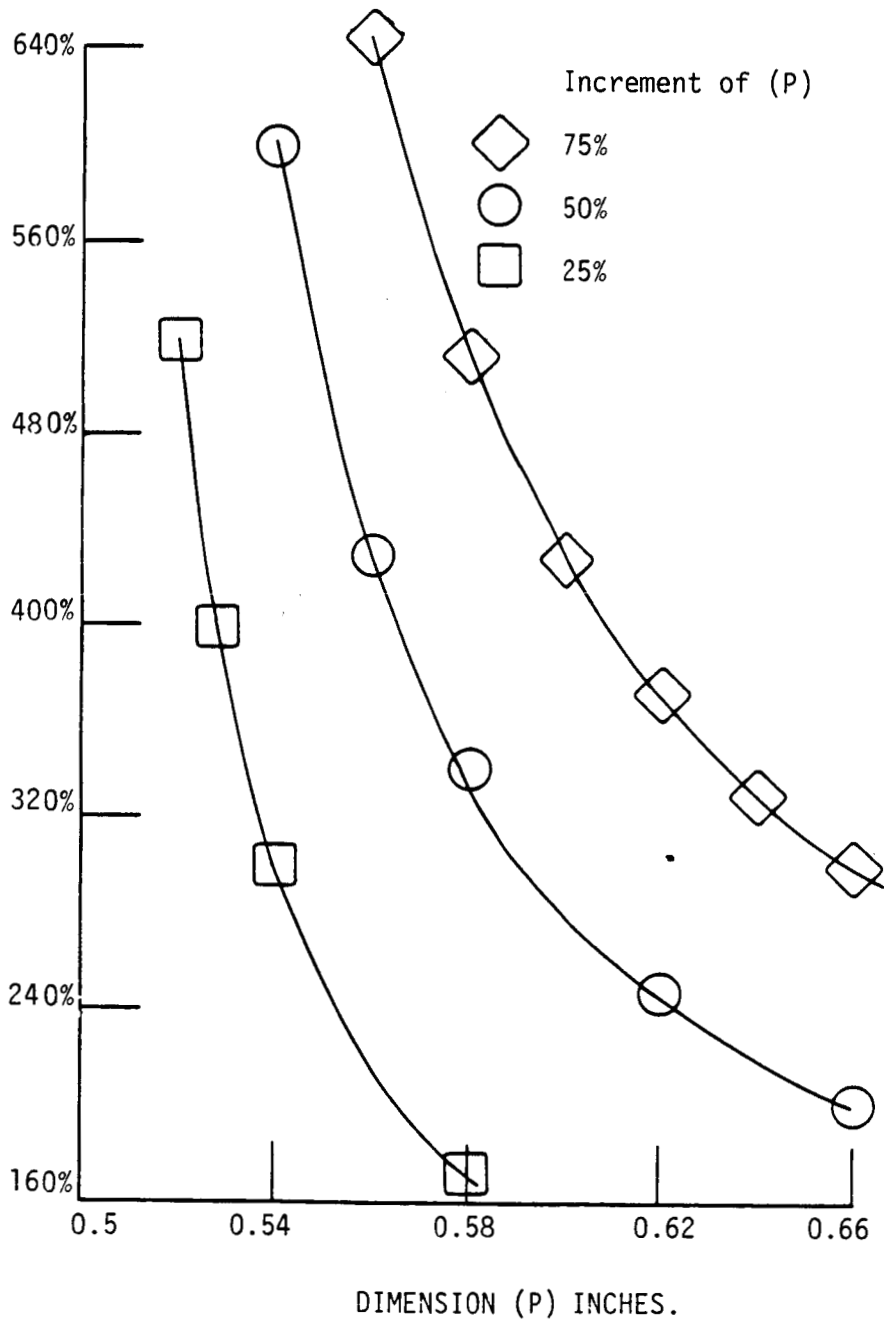

Figure 45. Effect of increase of length (P) on the frequency.

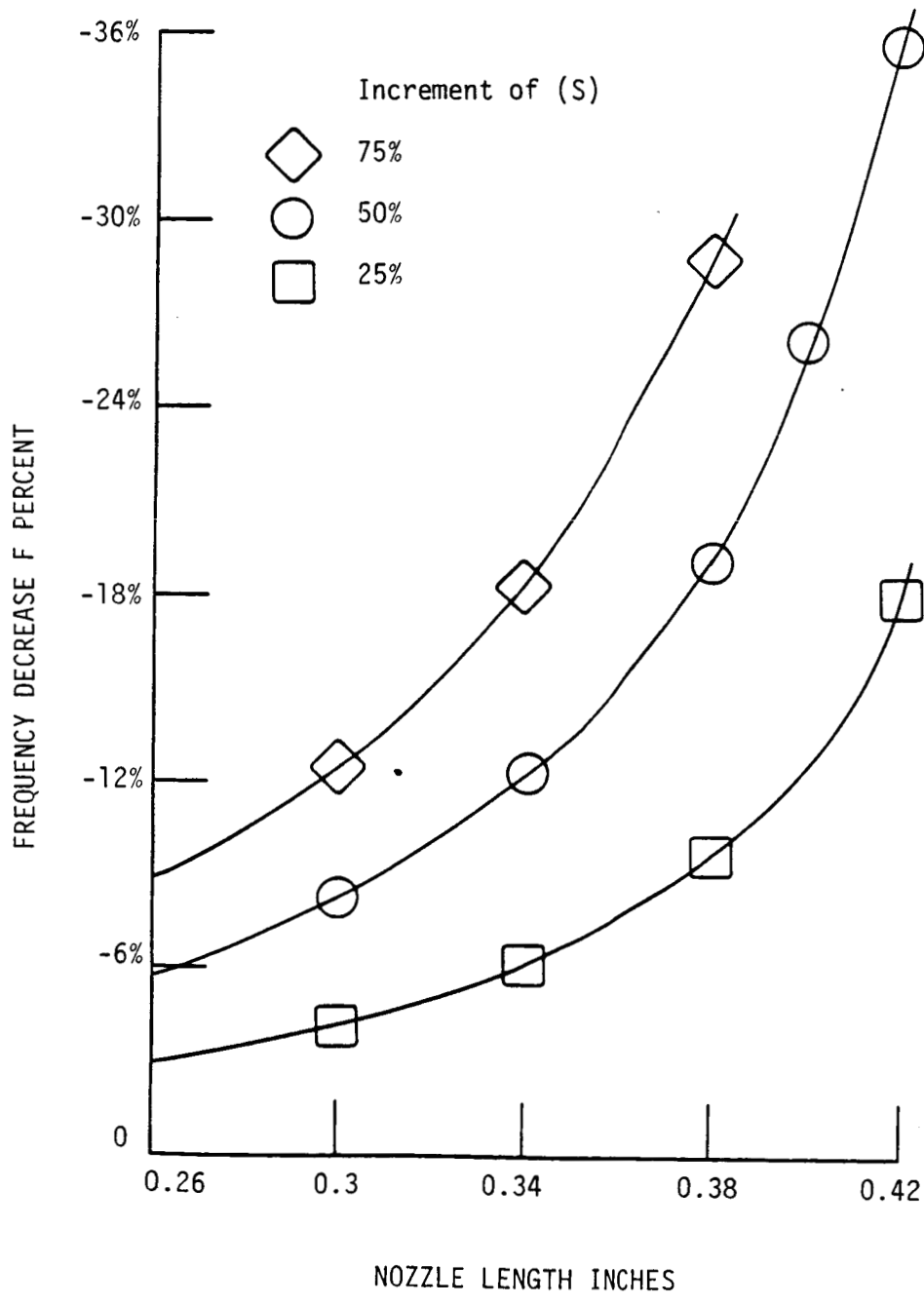

Figure 46. Effect of increase of nozzle length on frequency.

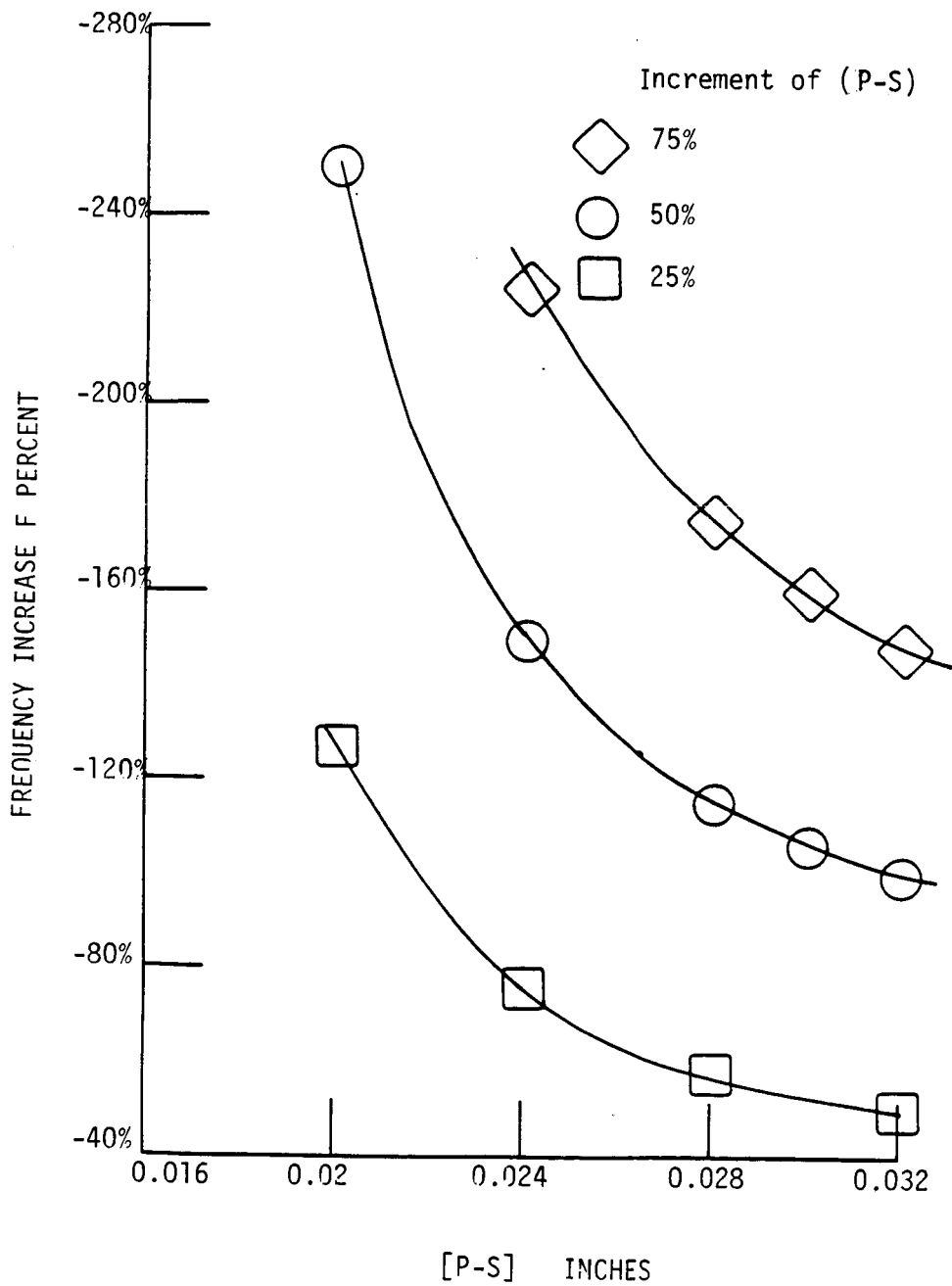

Figure 47. Effect of increase the pick up signal point length on frequency.

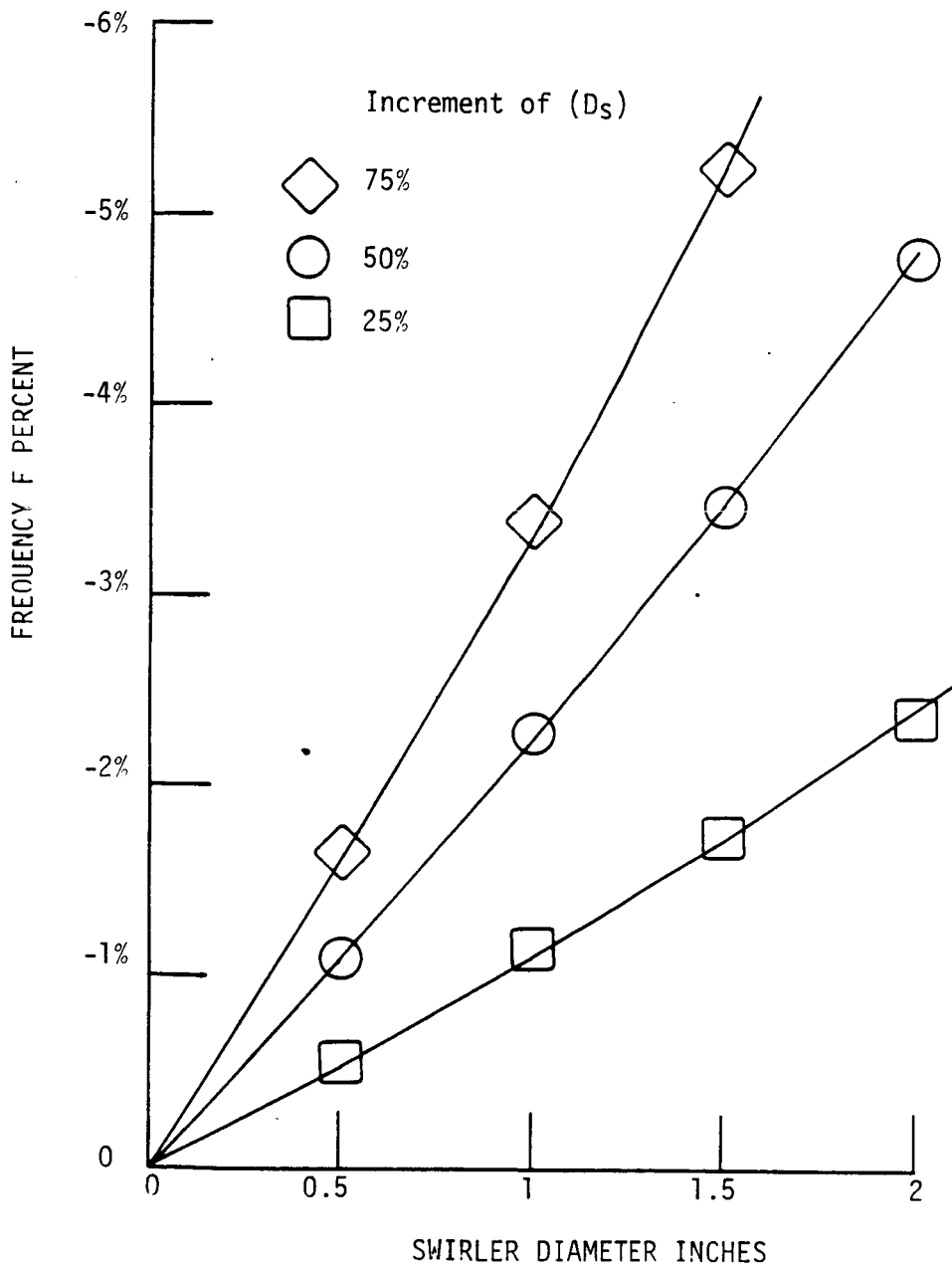
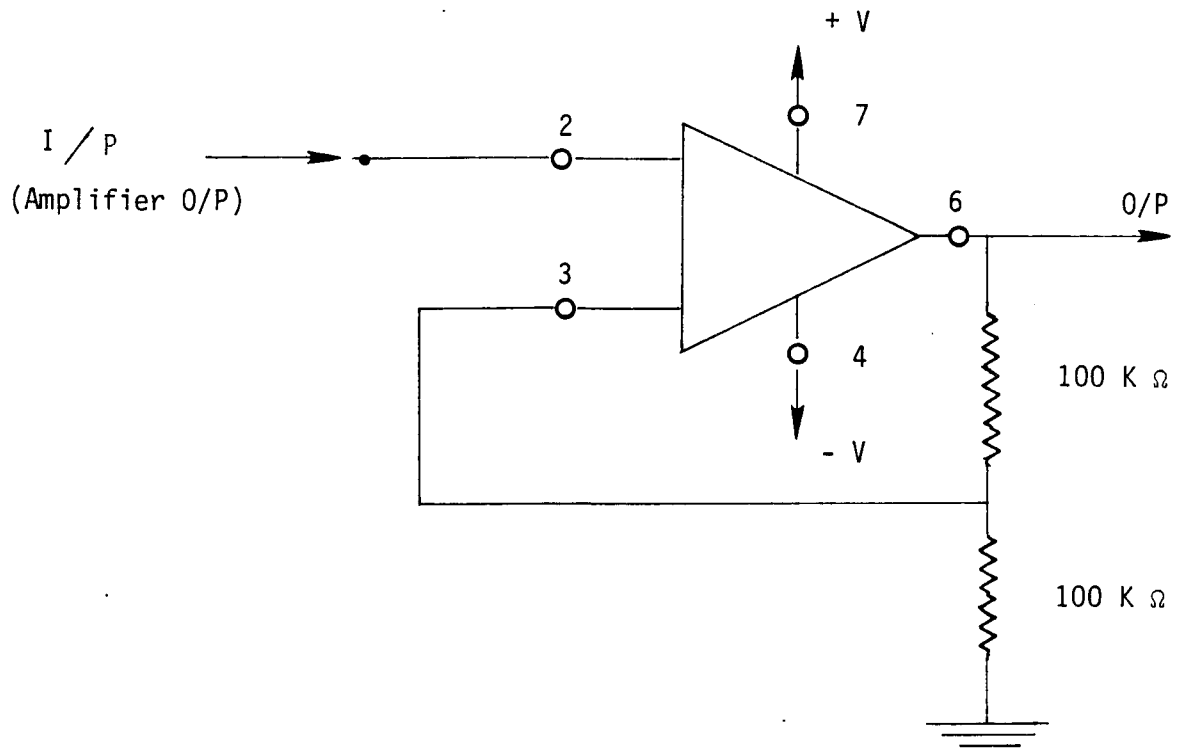

Figure 48. Effect of increase the swirler diameter on frequency.

APPENDIX

C-2



Swirler	1	2	3	4	5
Diameter	2"	1.5"	1"	0.75"	0.5"

Figure A.1 Comparator circuit

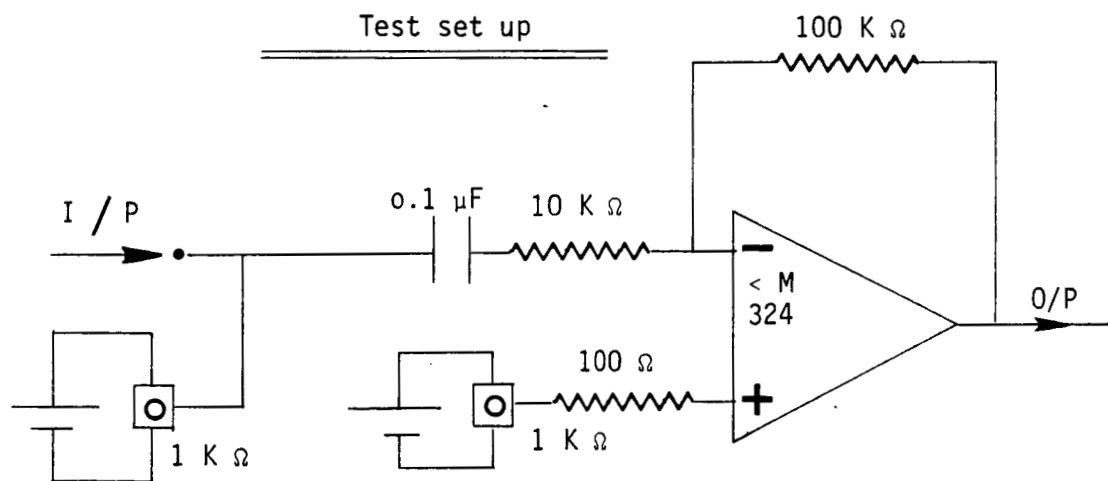
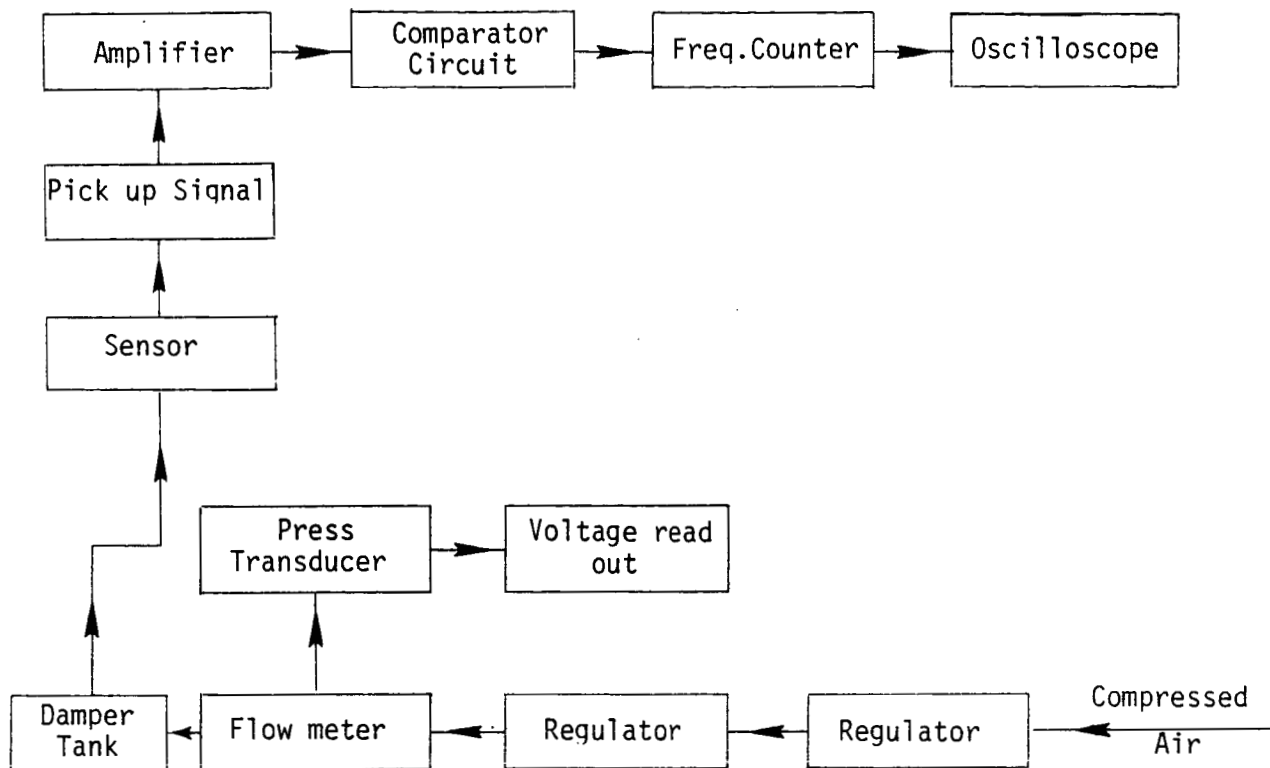
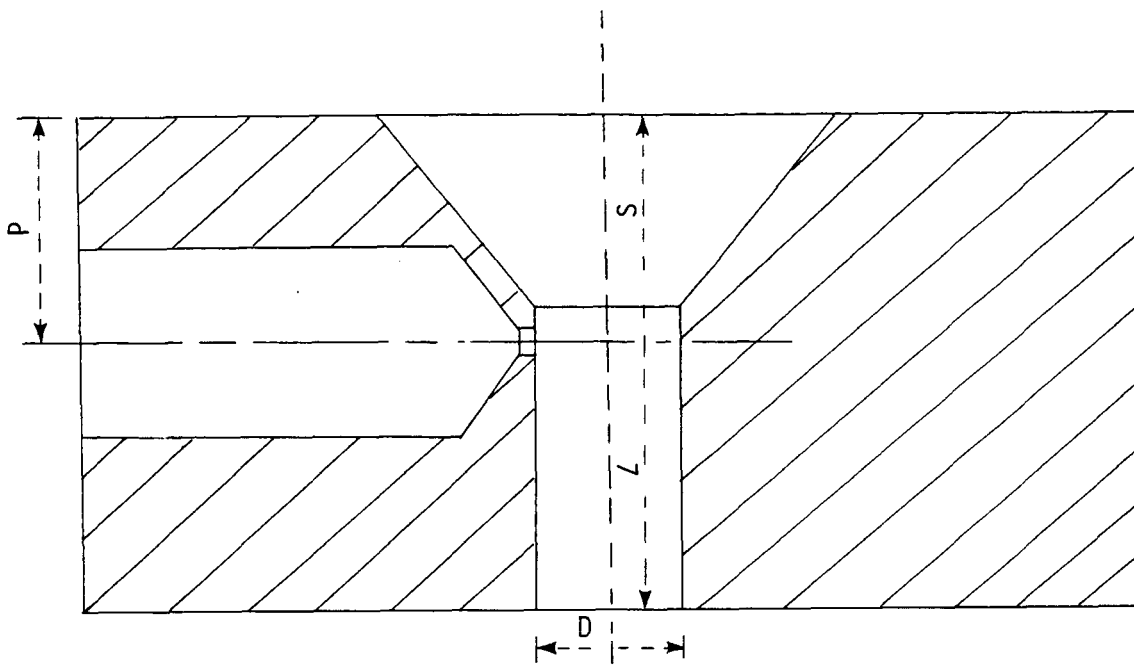

Figure A.2 Input Amplifier



Item Sensor	D	L	S	d	P
1	0.375"	0.750"	0.380	0.0145	0.394
2	"	"	0.380	"	0.383
3	"	"	0.385	"	0.394
4	"	0.184	0.372	"	0.383
5	0.250	0.403	0.472	"	0.490
6	"	0.472	0.472	"	0.500
7	"	0.631	0.494	"	0.492
8	"	0.641	0.484	"	0.500

Figure A.3 Sensor dimensions