

N87-28787

ORIGINAL PAGE IS  
OF POOR QUALITY

## Compound-Taper Feedhorn for the DSN 70-Meter Antennas

F. Manshadi and R. Hartop

Radio Frequency and Microwave Subsystems Section

*A novel X-band feedhorn has been designed for the DSN 70-meter antennas. The feedhorn is a compound-taper structure consisting of a corrugated flared section (standard JPL 22-dB feedhorn) and a corrugated straight section (stovepipe). This feedhorn is designed to closely initiate the characteristics of the standard feedhorn, while providing the proper phase center location, without adding any significant loss to the system. The use of an existing feedhorn and the ease of manufacturing the stovepipe have resulted in major overall system cost savings.*

### I. Introduction

The new DSN 70-meter Cassegrainian antennas are a modification of the old 64-meter antennas at Goldstone, California, Canberra, Australia, and Madrid, Spain. The reflectors of these antennas are shaped to optimize theoretical patterns based on the characteristics of the JPL standard 22-dB feedhorn [1]. However, the standard feedhorn is much shorter than the dual hybrid mode feedhorn [2], [3] of the 64-meter antennas. Therefore, if the standard horn was to replace the dual mode feedhorn, the new phase center would fall far below the proper location considered in the design of the 70-meter antennas. Modifications would entail either elevating all the low noise equipment connected to the feedhorn (for which a rough cost estimate was around \$735K), or extending the length of the feed by adding a piece of circular waveguide to its input section, which would significantly add to the loss of the overall system. A third alternative was to design a new longer feedhorn that would exhibit the same characteristics of the JPL standard feedhorn. To avoid the cost of designing a

whole new feedhorn, it was decided to try a new idea (NASA Technical Brief NPO-16594) of using a straight corrugated section on top of the standard feedhorn in order to move the phase center to the designed location. If this compound-taper feedhorn did not degrade the characteristics of the standard horn significantly, it would be the least expensive solution (rough cost estimate of around \$225K), and would provide a technique for handling all such changes that will be required in the future.

A computer program that originally was developed for cylindrical corrugated waveguides was modified to make it applicable for the analysis of the flared and compound feedhorn. The results from this computer code were extensively validated by checking against measured data and data obtained from other programs used for analyzing corrugated horns. Then the compound feedhorn was designed and its characteristics were compared with the JPL standard feedhorn over a wide range of frequencies.

\*

C-2

## II. Design Approach

The geometries of the standard JPL feedhorn and the dual hybrid mode feedhorn are shown in Fig. 1 (a and b). The new 70-meter antennas are designed based on the assumption that the standard feedhorn is used in place of the dual hybrid mode feedhorn, but that the location of the phase center would be the same as that of the 64-meter antennas. This means that the new feedhorn must have its phase center at 39.679 inches above the reference plane, which is the plane of the old feedhorn input section. Therefore, if the standard feedhorn is used without any modification, its phase center would fall 16.51 inches below the designed location. In the new antennas, a 4.5-inch-long Phase Calibration Generator (PCG) coupler [4] is added in front of the feedhorn. This will push the phase center 4.5 inches higher and hence, as can be seen in Fig. 1(c), the desired phase center would fall 8.89 inches above the aperture of the standard feedhorn. We will show that the phase center of the standard horn can be moved to the desired point by adding an 8.4-inch stovepipe on the top.

The design tool used is the Scattering Matrix computer code<sup>1</sup> developed at JPL, which is based on a modal field-matching technique by James [5]. In this program, a corrugated structure is modeled as a large number of straight waveguide sections of different radii connected in series. In each section, the fields are expressed in terms of the normal modes of a circular waveguide and are matched at each discontinuity boundary. After the fields are evaluated, a scattering matrix is computed that relates the amplitudes of the reflected and transmitted modes of the structure to the amplitudes of the incident modes. This approach can be summarized by two matrix equations:

$$b_1 = [S_{11}] a_1$$

$$b_2 = [S_{21}] a_1$$

where  $a_1$  contains the input mode amplitudes,  $b_1$  the reflected modes, and  $b_2$  the output modes. The matrices  $[S_{11}]$  and  $[S_{21}]$  are scattering matrices that are determined by the computer code. The program has been used extensively for corrugated cylindrical waveguides [6], [7], and its results have shown excellent agreement with experimental results and other theoretical methods.

One of the features of this computer code is that the number of modes used for expansion of the fields in each section is proportional to the radius of that section. For the analysis

of feedhorns where the radius of the corrugated sections increases from the input port to the aperture plane, this feature can cause the number of modes to become prohibitively large. Therefore, the program was modified to keep the number of modes between 20 and 30. This was tested and found to be a large enough number of modes for proper convergence of the solution for the standard feedhorn.

The standard JPL feedhorn is made of corrugated sections that are not perpendicular to the axis of the feedhorn and therefore cannot be treated as pieces of cylindrical waveguide. These corrugations were approximated by cylindrical sections (see Fig. 2) that are suitable for the Scattering Matrix program. This new approximate geometry was then used in the computer code, and the far-field patterns of the feedhorn were computed at 8.45 GHz (the center frequency for the receive band). These far-field patterns were compared with the measured patterns and computed patterns using an older JPL computer code called the Hybridhorn program. This program was one of the tools used for design of the JPL standard feedhorn. Figure 3 shows the expanded *E*-plane pattern of the standard feedhorn obtained from the two computer codes and the measurements. As can be seen, there is good agreement between all results. In particular, it seems that the results from the Scattering Matrix program are closer to the measured data than the results from the Hybridhorn program.

To move the phase center of the feedhorn, a section of stovepipe was added to the standard feedhorn. The stovepipe consisted of cylindrical sections with the same corrugation dimensions of the standard horn as shown in Fig. 4. To find the proper length, several lengths of stovepipe section were added to the standard feedhorn, and the variation of the overall phase center location was computed and plotted vs the length of the stovepipe at 8.45 GHz. Figure 5 shows this variation for two values of corrugation depth: one at 0.434 inches, which is the depth of the standard horn corrugation, and the other at 0.350 inches. These plots show the phase center oscillating back and forth about the aperture plane, and that it is possible to select either a positive or a negative location with respect to the aperture. The phase center location for the standard horn alone and with two stovepipes, one 11.76-inch long with a 0.434-inch corrugation depth and the other 5.59-inches long with a 0.350-inch corrugation depth, were measured and are shown by solid circles on the plots of Fig. 5. To find the proper length for the stovepipe that moves the phase center 8.89 inches above the aperture of the standard feedhorn, the data of Fig. 5 was translated to show the phase center location in reference to the aperture of the standard feedhorn. This data is plotted in Fig. 6 vs the length of the stovepipe. It can be seen that for an 8.89-inch movement, the proper length for the stovepipe is about 8.6 inches. Since each cylindrical section in the stovepipe is 0.14 inches long,

<sup>1</sup>D. J. Hoppe, "Scattering Matrix Program for Circular Waveguide Junctions," JPL Interoffice Memorandum 3335-84-071 (internal document), Jet Propulsion Laboratory, Pasadena, Calif., Dec. 5, 1984.

## ORIGINAL PAGE IS OF POOR QUALITY

a 62-section stovepipe that is 8.68-inches long was required to approximately yield the proper phase center location.

A computer analysis of the compound-taper feedhorn with the 8.68-inch stovepipe showed minor degradation in the cross-polarization and sidelobe levels and about 0.5-dB higher gain. The higher gain, due to the narrower beam generated by the stovepipe, resulted in a lower illumination efficiency of the feedhorn. To remedy this problem, it was decided to reduce the size of the aperture of the stovepipe by reducing its radius. However, changing the radius caused a shift in the phase center. Therefore, the Scattering Matrix program was used and the compound-taper feed was analyzed for different values of radius and length of the stovepipe. The optimum stovepipe, with approximately the same gain and efficiency of the standard feedhorn, was found to be one with a radius of 3.24 inches and a length of 8.4-inches (60 cylindrical sections). The phase center of this feedhorn was computed to be located 0.6 inches in front of the stovepipe aperture. The new compound taper feedhorn had higher sidelobe and cross-polarization levels, but showed higher efficiency, flatter phase pattern, and a more stable phase center. Figure 7 shows one of the compound-taper feedhorns fabricated for the 70-meter antennas.<sup>2</sup> The 8.45-GHz *E*- and *H*-plane patterns of the compound-taper feedhorn are compared with the standard JPL feedhorn in Figs. 8 and 9. Excellent agreement can be seen for scan angles less than 16 degrees, which is the half-angle subtended by the 70-m antenna subreflector.

### III. Analysis

The compound-taper feedhorn and the JPL standard feedhorn have been extensively compared and analyzed by the Scattering Matrix program for several frequencies between 8.2 and 8.7 GHz. Most of the theoretical computations were checked with antenna range measurements, and good agreement was established for all cases.

Table 1 shows the variation of the phase center location of the compound feed and the standard feed, with respect to

<sup>2</sup>The complete detail geometry of this feedhorn is shown in JPL Drawing 9490170 (internal document), Jet Propulsion Laboratory, Pasadena, Calif.

their aperture plane, as a function of frequency. As can be seen, the phase center of the new feedhorn is more stable across the frequency range.

Table 2 shows the gain of the two feedhorns as a function of frequency. The gain variations are very similar, showing a slight increase as the frequency is increased, which is expected since the aperture size becomes effectively larger.

The sidelobe and cross-polarization levels for the two feedhorns are shown in Tables 3 and 4, respectively, as a function of frequency. These levels are both higher for the compound feedhorn, which in general is not desirable. However, these sidelobe and cross-polarization levels not only have peaks at angles corresponding to the subreflector's edge, but their absolute values are far below the co-polarized fields. Consequently, the slightly higher sidelobe or cross-polarization levels do not significantly degrade the performance of the overall antenna.

Table 5 shows the overall efficiency of the two feedhorns, over 16 degrees, as a function of frequency. It can be seen that the compound feedhorn and the standard feedhorn are almost equal in efficiency. The efficiency of the compound feed drops slightly at the upper edge of the frequency band due to higher sidelobe and cross-polarization levels.

### IV. Summary and Conclusions

A novel technique was used to design a compound-taper feedhorn to replace the dual hybrid mode horn of the 64-meter antennas. The new feedhorn, designed for the 70-meter upgrade of the 64-meter antennas, closely duplicates the characteristics of the JPL standard feedhorn, upon which the shape of the 70-meter antennas are based. The compound feedhorn introduces a phase center in front of its aperture, but in the required location with respect to the subreflector. The new feedhorn has been checked extensively by available computer codes and antenna range measurements over a large band of frequencies. Excellent agreement between theoretical and measured results was established, and the feedhorn was shown to perform as well as the standard feedhorn for all practical purposes. The implementation by this technique, rather than by relocating the traveling wave masers, has resulted in a cost savings to the DSN of one-half million dollars.

## Acknowledgment

The authors would like to thank W. Folwell and H. Reilly for antenna range measurements, and D. Hoppe for providing the Scattering Matrix program.

## References

- [1] R. Hartop, "X-band antenna feedcone assembly," *JPL Technical Report 32-1526*, vol. XIX, Jet Propulsion Laboratory, Pasadena, Calif., Nov. 1973.
- [2] R. Hartop, "New X-band antenna feeds for the DSN 64-meter stations," *DSN Progress Report 42-52*, pp. 71-74, Jet Propulsion Laboratory, Pasadena, Calif., May 1979.
- [3] A. J. Frieley, "Radio frequency performance of DSS 14 64-m antenna at X-band using a dual hybrid mode feed," *DSN Progress Report 42-53*, pp. 132-140, Jet Propulsion Laboratory, Pasadena, Calif., July, 1979.
- [4] P. H. Stanton, "X-band phase calibration generator coupler," *TDA Progress Report 42-90*, vol. April-June 1987, Jet Propulsion Laboratory, Pasadena, Calif., August 15, 1987.
- [5] G. L. James, "Analysis and design of  $TE_{11}$ -to- $HE_{11}$  corrugated cylindrical waveguide mode converters," *IEEE Trans. MTT*, vol. 29, No. 10, pp. 1059-1066, Oct. 1981.
- [6] D. J. Hoppe, "Propagation and radiation characteristics of a multimode waveguide feedhorn," *TDA Progress Report 42-82*, vol. April-June 1985, pp. 57-67, Jet Propulsion Laboratory, Pasadena, Calif., August 15, 1985.
- [7] D. Hoppe, W. Imbriale, and A. Bhanji, "The effects of mode impurity on Ka-band system performance," *TDA Progress Report 42-80*, vol. October-December 1984, pp. 12-23, Jet Propulsion Laboratory, Pasadena, Calif., February 15, 1985.

**Table 3. Sidelobe level of the standard and compound-taper feedhorns as a function of frequency**

Frequency, GHz	Sidelobe Level, dB	
	Standard Feedhorn	Compound-Taper Feedhorn
8.2	-25	-22
8.3	-25	-22
8.45	-25	-22
8.6	-25	-22
8.7	-25	-22

**Table 4. Cross-polarization levels for the standard and compound feedhorns as a function of frequency**

Frequency, GHz	Cross-Polarization Level, dB	
	Standard Feedhorn	Compound-Taper Feedhorn
8.2	-35.0	-33.5
8.3	-34.5	-33.0
8.45	-34.0	-32.0
8.6	-35.0	-32.0
8.7	-34.0	-31.5

**Table 5. Overall efficiency of the standard and compound-taper feedhorns as a function of frequency**

Frequency, GHz	Overall Efficiency, %	
	Standard Feedhorn	Compound-Taper Feedhorn
8.2	76.4	76.8
8.3	75.8	76.0
8.45	74.4	74.4
8.6	73.2	72.8
8.7	72.3	71.6

**Table 1. Phase center location in reference to the aperture for the standard and compound-tapered feedhorns as a function of frequency<sup>a</sup>**

Frequency, GHz	Phase Center Location, in.	
	Standard Feedhorn	Compound-Taper Feedhorn
8.2	+2.20	-0.62
8.3	+2.30	-0.59
8.45	+2.52	-0.61
8.6	+2.70	-0.56
8.7	+2.83	-0.52

<sup>a</sup>Positive values are for the phase center below the aperture, while negative values are for the phase center above the aperture.

**Table 2. Gain of the standard and the compound-taper feedhorns as a function of frequency**

Frequency, GHz	Gain, dB	
	Standard Feedhorn	Compound-Taper Feedhorn
8.2	22.2	22.0
8.3	22.3	22.1
8.45	22.5	22.3
8.6	22.6	22.5
8.7	22.7	22.6

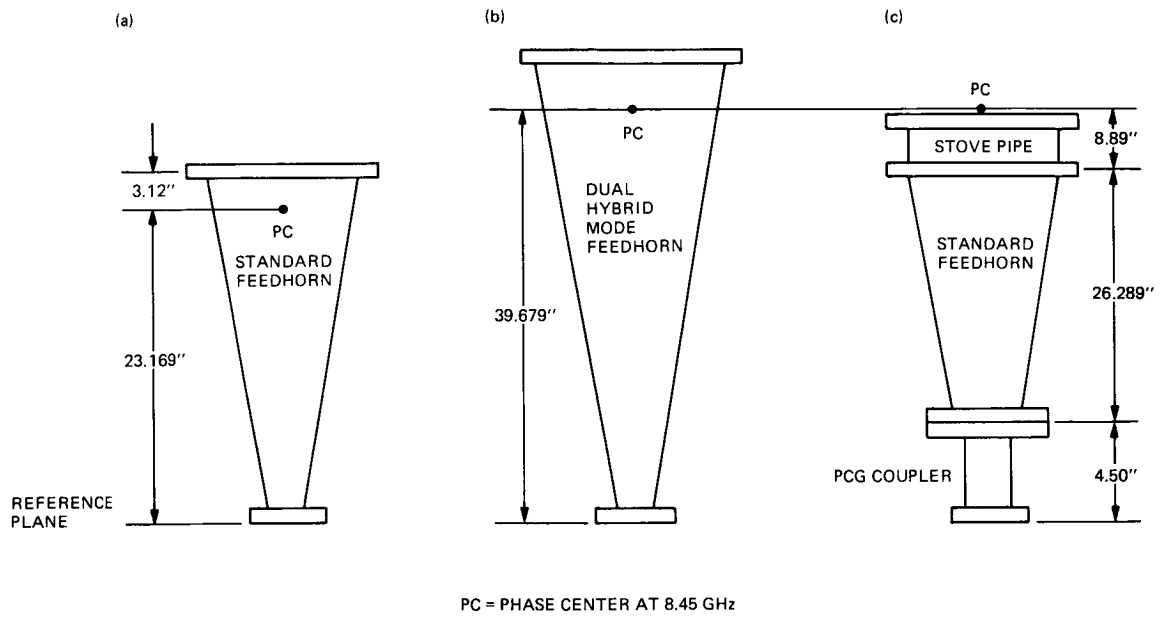

**Fig. 1. Comparison of feedhorns and the location of their phase centers: (a) standard JPL 22-dB feedhorn, (b) dual hybrid feedhorn of 64-m antennas, (c) compound-taper feedhorn**

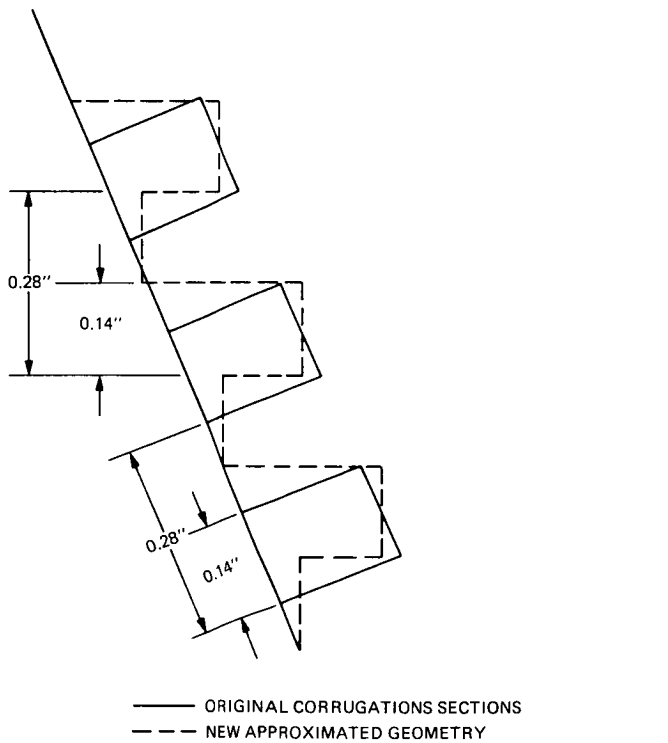

**Fig. 2. Approximation of the standard JPL feedhorn corrugations by cylindrical sections**

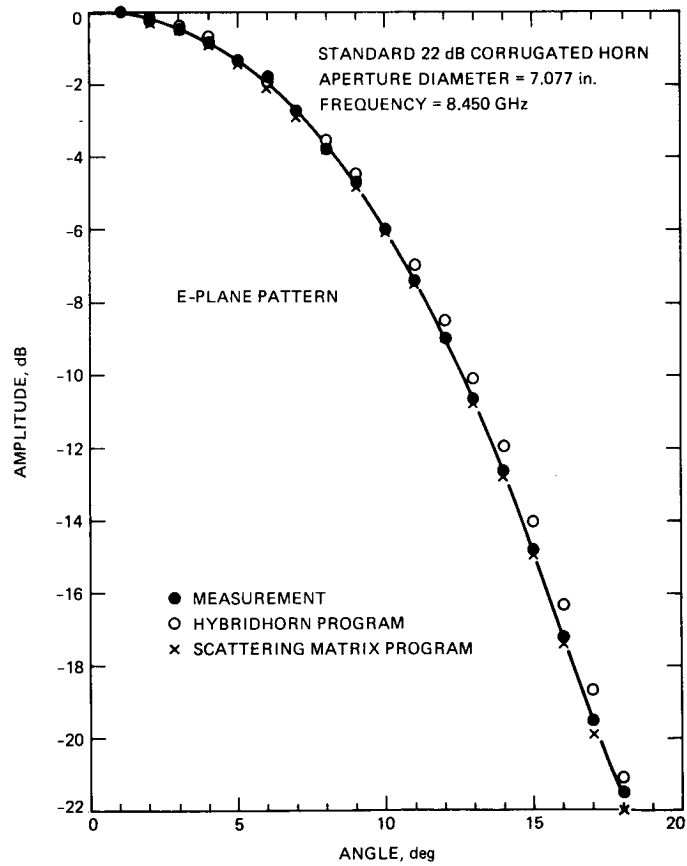

**Fig. 3. Expanded E-plane pattern of the JPL standard feedhorn**

ORIGINAL PAGE IS  
OF POOR QUALITY

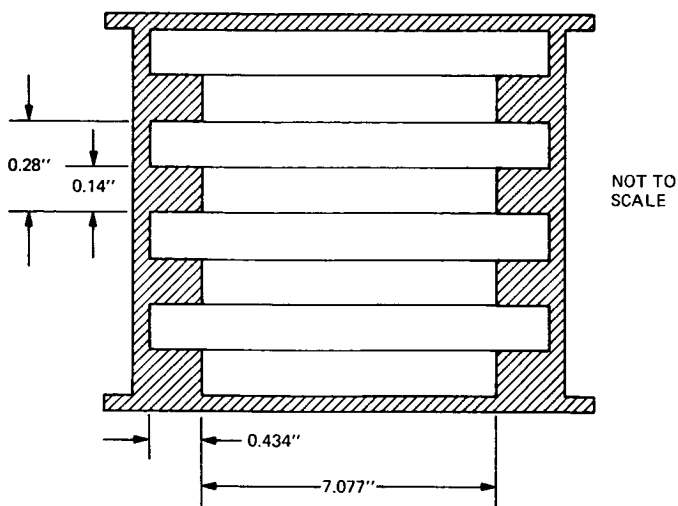

Fig. 4. Cross-section geometry of an eight-section stovepipe with the same corrugation dimensions and radius as the standard feedhorn

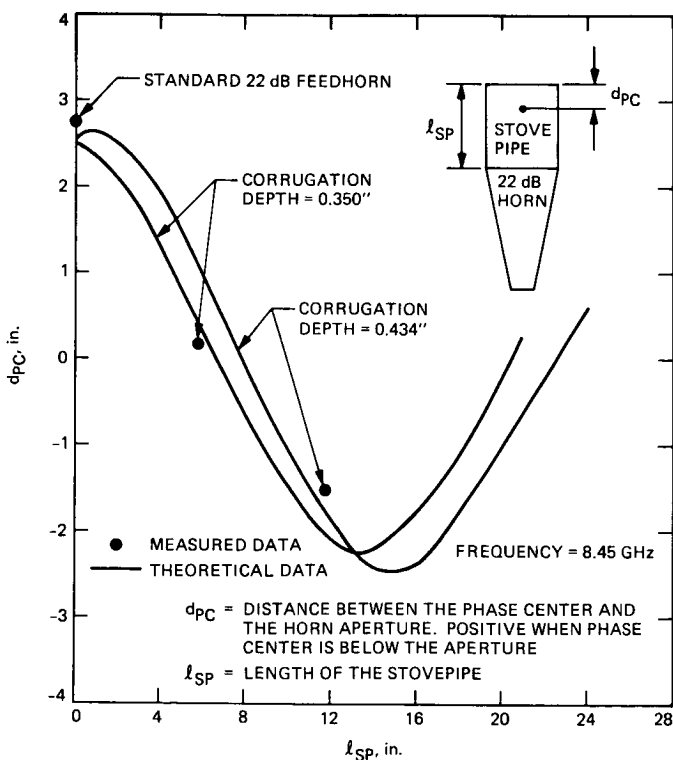

Fig. 5. Variation of phase center location as a function of the stovepipe in a compound feedhorn

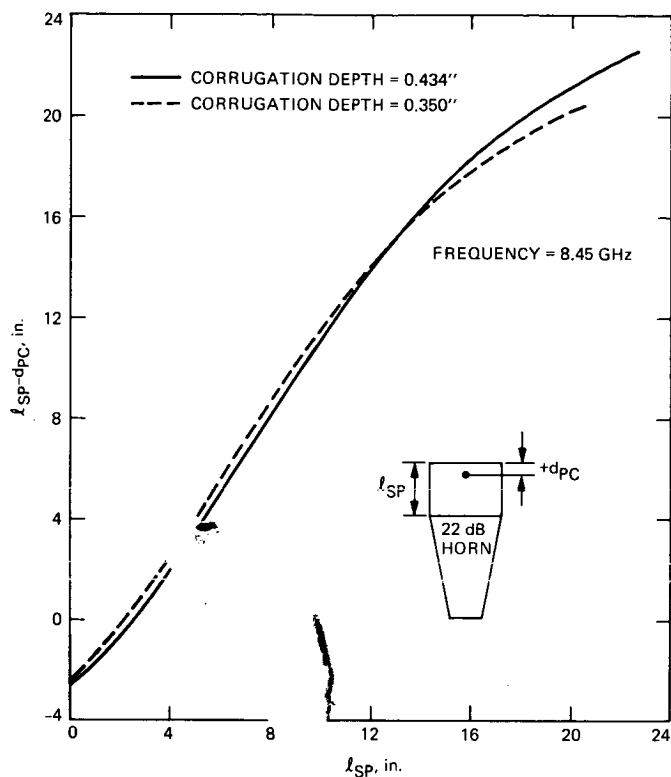

Fig. 6. Phase center location of the compound feedhorn with respect to the standard feedhorn aperture plane

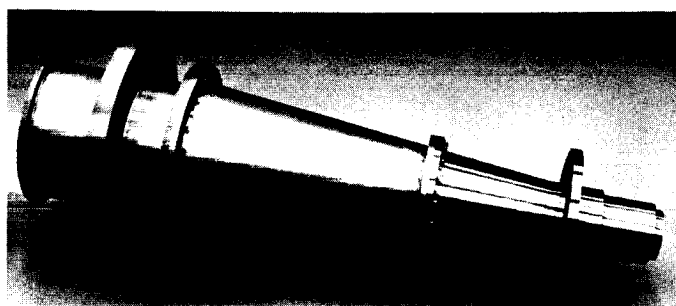

Fig. 7. Compound-taper feedhorn for DSN 70-m antennas

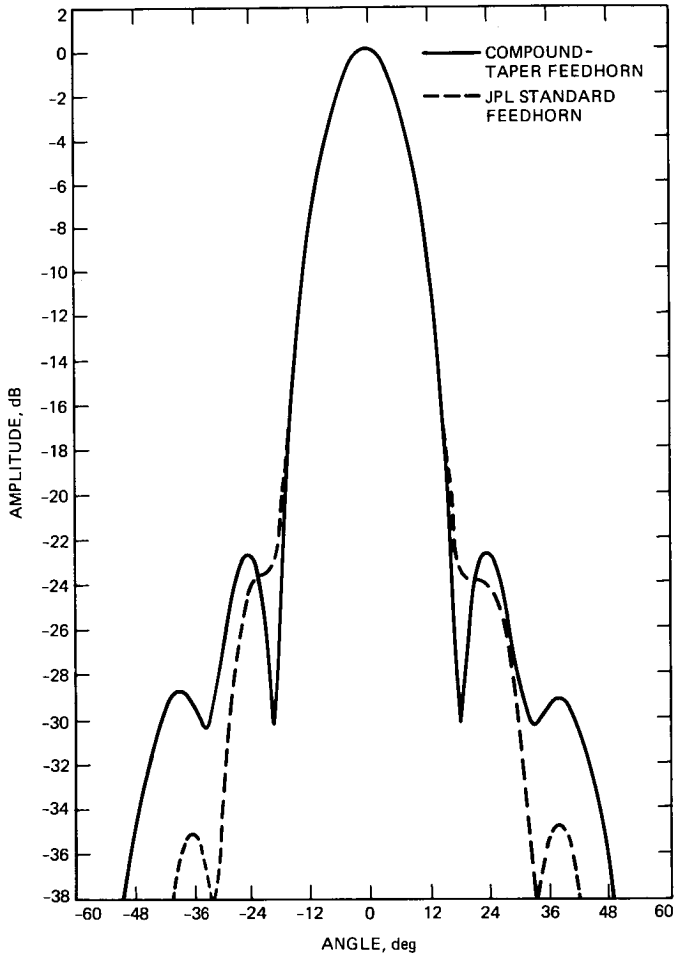

Fig. 8. The *E*-plane patterns of the JPL standard and the compound-taper feedhorns at 8.45 GHz

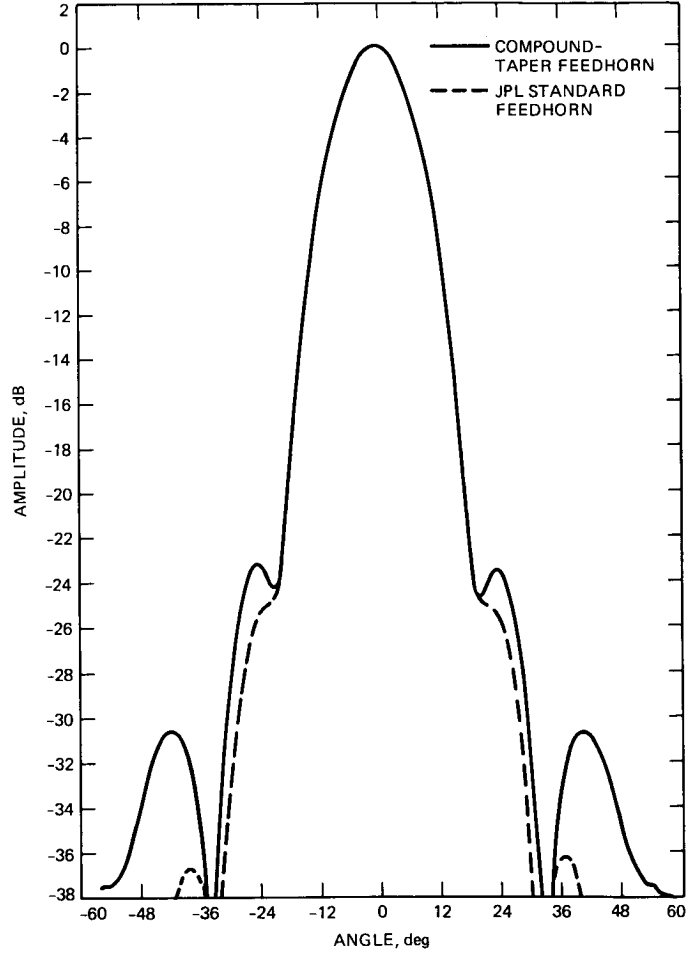

Fig. 9. The *H*-plane patterns of the JPL standard and the compound-taper feedhorns at 8.45 GHz