

NASA Technical Memorandum 89901

Profile Modification to Minimize Spur Gear Dynamic Loading

Hsiang Hsi Lin
Memphis State University
Memphis, Tennessee

and

Dennis P. Townsend and Fred B. Oswald
Lewis Research Center
Cleveland, Ohio

Prepared for the
Design Engineering Technical Conference
sponsored by the American Society of Mechanical Engineers
Orlando, Florida, September 24-28, 1988



(NASA-TM-89901) PROFILE MODIFICATION TO
MINIMIZE SPUR GEAR DYNAMIC LOADING (NASA)
22 p Avail: NTIS HC A02/MF A01 CSCL 131

N87-28918

Unclas
G3/37 0098898

PROFILE MODIFICATION TO MINIMIZE SPUR GEAR DYNAMIC LOADING

Hsiang Hsi Lin*
Memphis State University
Memphis, Tennessee 38152

Dennis P. Townsend and Fred B. Oswald
National Aeronautics and Space Administration
Lewis Research Center
Cleveland, Ohio 44135

SUMMARY

E-3597 An analytical computer simulation program for dynamic modeling of low-contact-ratio spur gear systems is presented. The procedure computes the gear static transmission error and uses a fast Fourier transform to generate its frequency spectrum at various tooth profile modifications.

The dynamic loading response of an unmodified (perfect involute) gear pair was compared with that of gears with various profile modifications. Correlations were found between various profile modifications and the resulting dynamic loads. An effective error, obtained from frequency domain analysis of the gear's static transmission error, gave a very good estimation of gear dynamic loading.

Design curves generated by dynamic simulation at several profile modifications are given for gear systems operated at various applied loads. Optimum profile modifications can then be determined from the design curves to yield a minimum dynamic effect for a gear system and to provide up-to-date knowledge for better gear design.

NOMENCLATURE

- A_e effective error of static transmission error, $A_e = A_1 + \left[\sum_{i=1}^{12} A_i^2 \right]^{1/2}$, μm
- A_i amplitude of i^{th} frequency component of gear pairs static transmission error, μm
- C_s, C_g damping values of shafts and gear tooth mesh N-m-sec; N-sec
- E_p pitch error, μm
- E_{ξ}^{ab} combined spacing error between succeeding tooth pairs a and b, μm
- E_t transmission error
- J polar mass moment of inertia, $\text{m}^2\text{-kg}$

*NASA Lewis Research Center Summer Faculty Fellow.

K stiffness, N-m/rad
 L_n normalized length of tooth profile modification zone
 Q^a, Q^b combined meshing compliances of the contacting tooth pairs a and b, $\mu\text{m}/\text{N}$
 R_b base radius, m
 T torque, N-m
 W_n total transmitted load, N/m
 W^a, W^b shared tooth loads for tooth pairs a and b, N/m
 Δ reference value of profile modification; minimum amount of tip relief recommended by Welbourn, μm
 θ angular displacement, rad
 $\dot{\theta}$ angular velocity, rad/sec
 $\ddot{\theta}$ angular acceleration, rad/sec²

Subscripts:

f tooth contact friction
 g meshing tooth pair
 L load
 λ output torque
 M motor
 m input torque
 $s1$ shaft 1
 $s2$ shaft 2
 1 gear 1
 2 gear 2

Superscripts:

a leading tooth pair
 b lagging tooth pair

INTRODUCTION

Reducing the dynamic loading and noise of gear systems has been an important concern in gear design. Many researchers have found that the noise generated from gearing is basically due to gearbox vibration excited by the dynamic load (refs. 1 to 9). This vibration is transmitted through shafts and bearings to noise-radiating surfaces on the gearbox exterior. Minimizing gear dynamic loading will reduce gear noise.

The principal source of gear system vibration is the unsteady component of the relative angular motion of meshing gear pairs. The static transmission error describes this displacement type of vibratory excitation. The variation of gear-pair meshing tooth stiffness, which causes static transmission error, is primarily due to the periodic alternation in the numbers of contacting teeth. Secondary effects include tooth profile modifications, machining errors, and wear.

Modifying the gear tooth profile has been found to significantly affect tooth meshing stiffness. Therefore, minimizing meshing stiffness variation to achieve a smooth static transmission error has become a widely used practice for reducing gear dynamic load. Much research has been done in this area, yet to the best of the authors' knowledge there is a lack of systematic work leading to detailed understanding of how tooth profile modification affects the dynamic response of spur gear systems.

This paper presents an analytical procedure and associated computer simulation to systematically change the length of the modified zone and the total amount of profile modification and to study how this affects the static transmission error and dynamic loading of spur gears. A method is presented for minimizing dynamic loading through an optimized profile modification to produce quieter spur gears.

The dynamic load and transmission error for an involute spur gear pair and for various modified gear pairs are presented in the time domain (as either degrees of roll angle or rotational speed) and in the frequency domain. The effect of various profile modifications on gear dynamics is discussed. The characteristics of dynamic loading and the Fourier spectrum of the tooth pairs' transmission error are compared. On the basis of this comparison an effective error, weighted from the frequency components of static transmission error, is recommended as a criterion for optimum profile modification to minimize gear dynamic load. This procedure will produce a gear set optimized for one particular design load.

For a gear system that must operate over a range of loads (rather than at a steady design load), several curves are provided that allow the designer to make intelligent tradeoffs to produce a quiet gearbox.

THEORETICAL ANALYSIS

The dynamic model used for the spur gear system was based on that of Lin and Huston (ref. 10). Other researchers (refs. 4, 6, and 11) have used a similar system dynamic model approach. The theoretical model, as shown in figure 1, comprises three basic elements of a spur gear system, (1) the gears,

(2) the shafts, and (3) the connected masses. Given this model, the governing equations developed, using basic gear geometry and elementary vibration principles, may be expressed as follows:

$$J_M \ddot{\theta}_M + C_{s1}(\dot{\theta}_M - \dot{\theta}_1) + K_{s1}(\theta_M - \theta_1) = T_m$$

$$J_1 \ddot{\theta}_1 + C_{s1}(\dot{\theta}_1 - \dot{\theta}_M) + K_{s1}(\theta_1 - \theta_M) + C_g(R_{b1}\dot{\theta}_1 - R_{b2}\dot{\theta}_2) + K_g[R_{b1}(R_{b1}\theta_1 - R_{b2}\theta_2)] = T_{f1}$$

$$J_2 \ddot{\theta}_2 + C_{s2}(\dot{\theta}_2 - \dot{\theta}_1) + K_{s2}(\theta_2 - \theta_1) + C_g(R_{b2}\dot{\theta}_2 - R_{b1}\dot{\theta}_1) + K_g[R_{b2}(R_{b2}\theta_2 - R_{b1}\theta_1)] = T_{f2}$$

$$J_L \ddot{\theta}_L + C_{s2}(\dot{\theta}_L - \dot{\theta}_2) + K_{s2}(\theta_L - \theta_2) = -T_d$$

Similar procedures developed by Cornell (ref. 8) and Tavakoli (ref. 9) were used to determine the tooth spring stiffness by modeling the elastic behavior of the gear tooth. The range of tooth contact was divided into a sequence of contact positions.

The meshing analysis for static transmission error and load-sharing computation is similar to that of Tavakoli and Houser (ref. 9). The load was assumed to be uniformly distributed along the tooth face width. Four equations were solved simultaneously to determine the load sharing and total transmission error of a low-contact-ratio (less than 2) mesh:

$$Q_i^a w_i^a + (E_t^a)_i = (E_p^a)_i$$

$$Q_i^b w_i^b + (E_t^b)_i = (E_p^b)_i + E_s^{ab}$$

$$w_i^a + w_i^b = w_n$$

$$(E_t^a)_i = (E_t^b)_i$$

where the subscript i represents the contact point on the tooth profile and the superscripts a and b represent the leading and lagging tooth pairs, respectively.

The static transmission error has basic periodicities related to the gear tooth mesh frequency and the shaft rotational frequency. It consists of components attributable to elastic tooth deformations, to deviations of the tooth profile from the perfect involute profile, and to uniform lead or spacing errors. A Fourier spectrum analysis of the static transmission error wave

shows harmonic components that occur at integral multiples of the tooth meshing frequency (ref. 12). These components are caused by tooth deformation and the deviation of tooth surfaces from the perfect involute profile. The lower harmonic frequencies occur at the integral multiples of shaft rotating frequencies and are caused by tooth spacing errors. The equations of motion include excitation terms due to transmission errors. The contribution of each individual frequency component to the dynamic loading response of gear systems was investigated in this study.

The gear tooth meshing process leads to instantaneous load fluctuations on the teeth even under constant loading conditions. The magnitude of the load fluctuation is influenced by the damping effect of the lubricant and the proximity of the operating frequencies to the system natural frequencies. Structural damping was not considered.

To simplify the analysis, the dynamic process was defined in the rotating plane of the gear pair, and the differential equations of motion were developed by using the theoretical line of action. Damping due to lubrication, etc. is expressed as a constant damping factor that is the ratio of the damping coefficient to the critical damping value. The damping factor used for the tooth mesh was 0.10 (a typical value from gear research literature).

For convenience, the same amount and the same length of profile modifications were assumed to be applied to the tooth tip of both pinion and gear. Since modifying the root of one member has the same effect as modifying the tip of the mating member, all modification was assumed to be applied at the tooth tips. Extra care must be taken in modifying the roots of gear teeth because of the complex geometry, particularly on gears with small numbers of teeth. In some extreme cases with low-contact-ratio gears, root modification can destroy the effects of tip modification, making it preferable to give only tip modification (ref. 5).

The minimum amount of conventional tip relief was chosen as a reference value in this study. This reference value was designated Δ . According to Welbourn (ref. 13), the minimum tip relief should be equal to twice the maximum spacing error plus the combined tooth deflection evaluated at the highest point of single-tooth contact (HPSTC).

The analysis was applied to a sample set of gears as specified in table I. These are identical spur gears with solid gear bodies and with various linear profile (tip relief) modifications. A typical tooth profile showing both the unmodified (true involute) profile and a modified profile is illustrated in figure 2(a). A sample profile modification chart is shown in figure 2(b), where the amount of modification is 1.00Δ and the modification zone extends to the HPSTC. This length of modification from tooth tip to HPSTC is designated as the normalized length L_n . In this case, the modification length is $1.00 L_n$. Note that although the length of modification is shown as a vertical distance (parallel to the tooth axis in fig. 2(a)), it is actually defined in terms of the gear roll angle.

The optimum length of tip relief will allow loading to pass smoothly from one tooth to the next. The length required depends upon the contact ratio. Tip relief should not extend to the pitch radius unless the contact ratio is at least 2 (ref. 5). To evaluate the effect of the length of tip relief, the

modified zone was varied from zero to the pitch radius. Only linear tip relief was considered in this study. This means that the tip modification line (as in fig. 2(b)) is straight.

The equations of motion were solved by a linearized iterative procedure. The linearized equations were obtained by dividing the mesh period into n equal intervals. In the analysis, a constant input torque T_m was assumed. The output torque T_o was assumed to be fluctuating as a result of time-varying stiffness, friction, and damping in the gear mesh.

To start the solution iteration process, initial values of the angular displacement were obtained by preloading the input shaft with the nominal torque carried by the system. Initial values of the angular speed were taken from the nominal system operating speed.

The iterative procedure was as follows: the calculated values of angular displacement and angular speed after one period were compared with the assumed initial values. Unless the differences between them were smaller than preset tolerances, the procedure was repeated using the average of the initial and calculated values as new initial values.

RESULTS AND DISCUSSION

The foregoing analysis was applied to a typical set of low-contact-ratio spur gears whose specifications are given in table I. Since this is an analytical work, the choice of gears used can be arbitrary. Two identical gears with solid gear bodies were selected for the study.

As a control case, the dynamic solution at design load was calculated for the sample gear with unmodified (true involute) tooth profile. Plots of static transmission error and shared tooth load (fig. 3) were generated from the solutions of the simultaneous equations presented in the previous section.

To investigate the effect of tooth profile modification, the amount of modification was varied from 0.25 to 1.50 of the reference value Δ in increments of 0.25 Δ . At each amount of modification, the length of modification was also varied in fixed increments. If one of the tooth pairs in the double-contact region lost contact because of excessive profile modifications or tooth deflections, the meshing analysis equations were solved for the load and static transmission error of the tooth pair that maintained contact. Figure 4 shows how the static transmission error and the tooth load of a gear pair are affected by the change of the length of modification at a constant 1.25 Δ .

Frequency analysis of static transmission error was performed by taking the fast Fourier transform (FFT) of its time wave. A periodic time signal was selected to avoid possible leakage error. The dc component created by gear body windup was neglected; only the tooth meshing frequency component and its harmonics, which are the major vibratory excitation source of gear dynamics, were included in the analysis.

The beneficial effects of profile modification can be seen by comparing figures 5 and 6. These figures show the static transmission error, the Fourier spectrum of the static transmission error, and the dynamic factor as a function

of speed (a "speed sweep") for unmodified gears (fig. 5) and gears modified with 1.25 Δ linear tip relief along a modification length of 0.52 L_n (fig. 6). The dynamic factor is defined as the ratio of the maximum dynamic tooth load to the static tooth load.

Since gear noise and gear dynamic loading are often typified by strong components at the tooth mesh frequency and its first two multiples (ref. 9), the relation between the gear dynamic factor and the static transmission error's first three harmonics of the fundamental tooth mesh frequency was investigated. With no profile modification, abrupt changes in the transmission error (fig. 5(a)) produced a very strong line at the first harmonic of the tooth meshing frequency A_1 (fig. 5(b)). With profile modification, the changes in transmission error occurred more smoothly (fig. 6(a)). This resulted in a much reduced first harmonic, although the third harmonic increased. The unmodified gears had a strong resonance at about 11 000 rpm (fig. 5(c)). At this resonant speed the dynamic factor was about 2.2, which means that the maximum dynamic tooth load during contact was 2.2 times the static tooth load. The dynamic factor of the modified gears (fig. 6(c)) did not exceed 1.5. This represents a reduction of 32 percent in the maximum dynamic loading over that for the unmodified gears.

Comparing the first three peaks of Fourier spectrum with the gear dynamic factor in figures 5 and 6 shows that the gear dynamic factor seems to be related primarily to the magnitude of the fundamental tooth mesh frequency.

The maximum gear dynamic factor was related to the static transmission error's amplitudes of the first four harmonics of the tooth mesh frequency, designated as A_1 , A_2 , A_3 , and A_4 , for the sample gear at 1.00 Δ and varying lengths of modification (fig. 7). The trend of amplitude (shape of the curve) of the maximum gear dynamic factor with respect to the profile modification length was most similar to that of A_1 . That means that A_1 should be weighted more than any other frequency component in any relation between the gear dynamic factor and the Fourier frequency components of the static transmission error.

A suggested procedure for calculating an effective transmission error is to take the sum of A_1 with the square root of the sum of the squares of the first 12 Fourier harmonic components of tooth mesh frequency. Because the magnitudes of the harmonic components after the 12th harmonic are usually small, their contribution to the vibratory excitation of gear dynamics is negligible.

$$A_e = A_1 + \left[\sum_{i=1}^{12} A_i^2 \right]^{1/2}$$

This reference value is termed "effective error," since it comprises the frequency components of the static transmission error. The effect of profile modification length on effective error (curve A_e in fig. 7 (b)) correlates well with the gear dynamic factor curve (fig. 7(a)). The effective error of a gear tooth profile appears to be an excellent indicator for the gear dynamic factor. It may amplify the penalty of "mistuned" profile modification due to

the weighted effect of the A_1 component. Therefore, the effective error can be a sensitive device for optimizing gear tooth profile modification. It can be used for tuning the length and amount of profile modification in order to minimize possible dynamic excitation and thus lower the gear dynamic loading. The less the effective error, the smaller the gear dynamic loading. In addition, gear system dynamic factors can be determined without going through the time-consuming iteration procedure to solve the differential equations of motion. A simple calculation of the Fourier spectrum and effective error of the static transmission error will give a good estimate of the gear dynamic factor. Better gear dynamic design can be achieved with less time and effort by varying gear tooth profiles and evaluating the resultant effective error of the meshing tooth pairs.

From figure 8(a) it is apparent that the length of modification should be decreased for gears with a greater amount of modification to achieve the minimum dynamic effect. The optimum decrease depends on the amount of profile modification. For 1.25Δ , the minimum dynamic factor was obtained with a 20-percent length reduction from that for 1.00Δ . For gears with a greater amount of profile modification, the variation of the gear dynamic factor with respect to length of modification was more sensitive than for gears with a smaller amount of profile modification. The variation of the gear dynamic factor with length of profile modification was very similar to the effective error curve for both gears (fig. 8).

When the tooth profile modification amount is less than the minimum tip relief Δ , the length of profile modification should be increased to minimize dynamic effect (fig. 9). As in figure 8, the optimum length of modified tooth profile depends on the prescribed amount of profile modification. Here approximately $L_n = 1.09$ was optimum for 0.75Δ , $L_n = 1.21$ was optimum for 0.50Δ , and $L_n = 1.28$ was optimum for 0.25Δ . For gears with a smaller amount of profile modification, the length of modification has a less significant effect on the gear dynamic factor than for gears with a greater amount of profile modification.

Figure 10, which shows the effect of length of profile modification on the gear dynamic factor at various amounts of modification, can be used as a design chart to determine the optimum modification length for minimum dynamic effect. As an example, consider a gear with 1.00Δ (minimum amount of tip relief), operating at a load smaller than design load such that it is equivalent to operating along the curve represented by 1.50Δ (point C in fig. 10). The optimum length of profile modification in this case should be $0.68 L_n$ instead of $1.00 L_n$. If the gear mentioned above were operated at a range of loads equivalent to operating between the 1.00Δ curve and the 1.50Δ curve, the optimum length of modification should be $0.75 L_n$, corresponding to point A in figure 10, the intersection of the 1.00Δ curve and the 1.50Δ curve. The choice of point B, or point C, or any point other than A, would yield less desirable higher dynamic factors under this range of loads.

The envelope of minimum dynamic factors achievable for gears with the prescribed amount of profile modification is shown as dashed lines in figures 9 and 10. This envelope is more sensitive to length of modification for gears with a smaller amount of profile modification than for gears with a greater amount of profile modification.

Since the characteristic of effective error at varying modification lengths gives a good indication of the gear dynamic factor of a gear pair, an example is shown in figure 11. The sample gear in table I was used for this example with the tooth profile modified at 1.00 Δ for one gear and 1.25 Δ for the mating gear. The length of modification was $L_n = 0.65$ for both members. The relative position of the effective error curves in figure 11(a) should indicate a corresponding position for the dynamic factor curves in figure 11(b). For this particular case the gear dynamic factor was predicted to be approximately 1.4. The maximum gear dynamic factor calculated by solving the gear system equations of motion (fig. 11(c)) was found to be 1.39, indeed close to the value predicted from the effective error in figure 11(b).

CONCLUSIONS

An analysis and a computer program were developed to investigate the effect of linear profile modifications on the dynamic loading response of a spur gear system. The relation between the gear tooth dynamic factor and the tooth mesh frequency components of transmission error was also studied. Applying the program to a pair of identical low-contact-ratio spur gears revealed the following:

1. The dynamic characteristics of a spur gear system are affected significantly by tooth profile modifications.
2. The dynamic (load) factor can be simulated analytically by the effective error, which is calculated from the frequency components of a gear pair's static transmission error.
3. The effective error is a good indicator for tuning the length and amount of profile modification to reduce gear dynamic loading.
4. If gears are to be operated at less than the design load, the length of the modification zone should be reduced. Conversely, if gears are to be operated at greater than the design load, the length of modification should be increased.
5. An increase in the applied load (or a decrease in the total amount of tip relief) reduces the sensitivity of the gears to changes in the length of profile modifications.
6. The dynamic tooth loads on gears that must operate over a range of loads can be minimized by using profile modifications optimized according to the procedures outlined in this work.

The results obtained herein should be useful for predicting the vibration excitation of spur gear systems and for modifying tooth profiles for improved gear dynamic performance.

To fully understand and best utilize gear tooth profile modification, it is recommended that the analysis be extended to nonlinear profile modifications. Experimental tests should be performed to verify the analytical results.

REFERENCES

1. Harris, S.L., 1958, "Dynamic Loads on the Teeth of Spur Gears," Proceedings of the Institute of Mechanical Engineers, Vol. 172, No. 2, pp. 87-112.
2. Seireg, A. and Houser, D.R., 1970, "Evaluation of Dynamic Factors for Spur and Helical Gears," Journal of Engineering for Industry, Vol. 92, No. 2, pp. 504-515.
3. Terauchi, Y., Nadano, H., and Nohara, M., 1982, "On the Effect of the Tooth Profile Modification on the Dynamic Load and the Sound Level of the Spur Gear," JSME Bulletin, Vol. 25, No. 207, pp. 1474-1481.
4. Kubo, A. and Kiyono, S., 1980, "Vibrational Excitation of Cylindrical Involute Gears Due to Tooth Form Error," JSME Bulletin, Vol. 23, No. 183, pp. 1536-1543.
5. Smith, J.D., 1983, Gears and Their Vibration: A Basic Approach to Understanding Gear Noise, Marcel Dekker, New York.
6. Kasuba, R. and Evans, J., 1981, "An Extended Model for Determining Dynamic Loads in Spur Gearing," Journal of Mechanical Design, Vol. 103, No. 2, pp. 398-409.
7. Cornell, R.W. and Westervelt, W.W., 1978, "Dynamic Tooth Loads and Stressing for High Contact Ratio Spur Gears," Journal of Mechanical Design, Vol. 100, No. 1, pp. 69-76.
8. Cornell, R., 1981, "Compliance and Stress Sensitivity of Spur Gear Teeth," Journal of Mechanical Design, Vol. 103, No. 2, pp. 447-459.
9. Tavakoli, M.S. and Houser, D.R., 1986, "Optimum Profile Modifications for the Minimization of Static Transmission Errors of Spur Gears," Journal of Mechanisms, Transmissions, and Automation in Design, Vol. 108, No. 1, pp. 86-95.
10. Lin, H.H. and Huston, R.L., 1986, "Dynamic Loading on Parallel Shaft Gears," NASA CR-179473.
11. Pintz, A., Kasuba, R., Frater, J.L., and August, R., 1983, "Dynamic Effects of Internal Spur Gear Drives," NASA CR-3692.
12. Mark, W.D., 1978, "Analysis of the Vibratory Excitation of Gear Systems: Basic Theory," Journal of the Acoustical Society of America, Vol. 63, No. 5, pp. 1409-1430.
13. Welbourn, D.B., 1979, "Fundamental Knowledge of Gear Noise - A Survey," Noise and Vibration of Engines and Transmissions, Mechanical Engineering Publications, London, pp. 9-14.

TABLE I. - GEAR DATA

| | |
|--|---------------------------|
| Gear tooth | Standard full-depth tooth |
| Module (diametral pitch), mm | 3.18 (8) |
| Pressure angle, deg | 20 |
| Number of teeth | 28 |
| Face width, mm (in.) | 25.4 (1.0) |
| Design load, N/m (lb/in.) | 350 000 (2000) |
| Theoretical contact ratio | 1.64 |

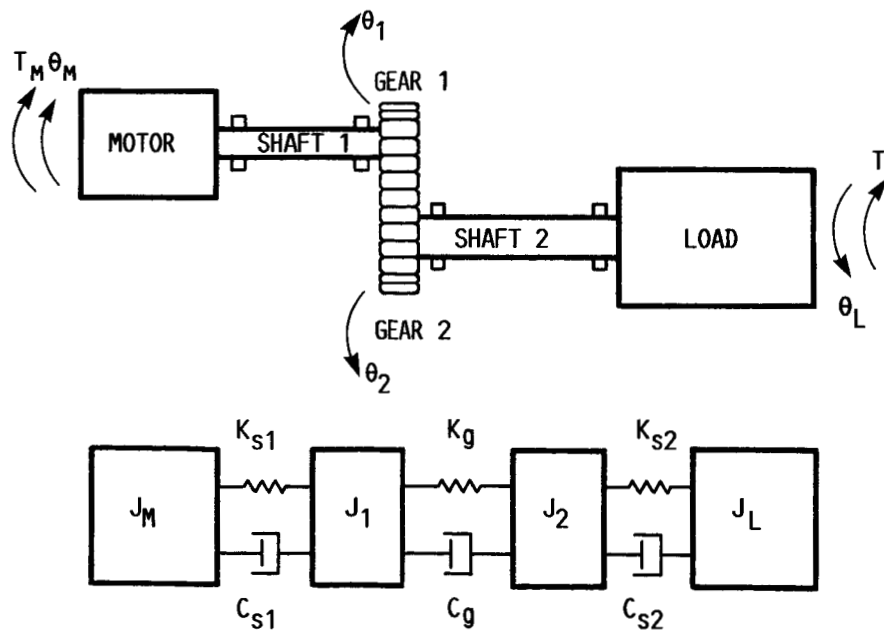
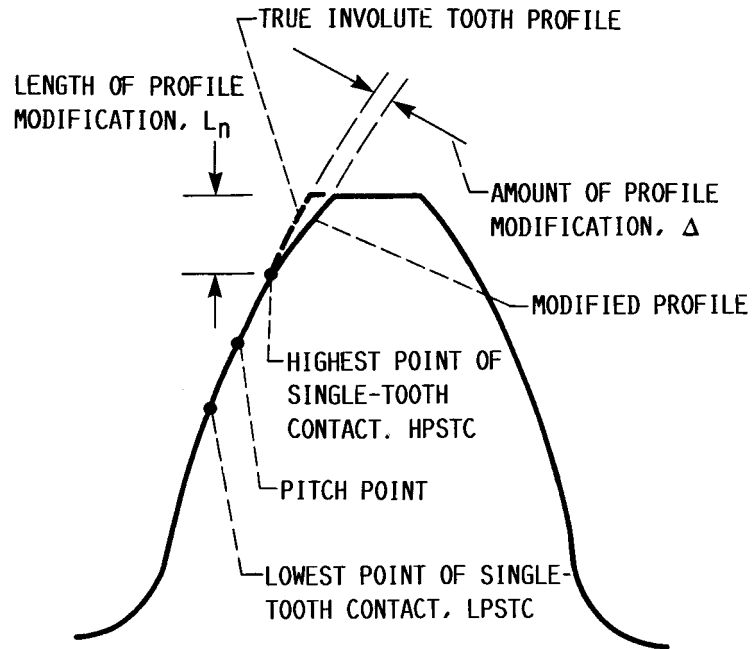
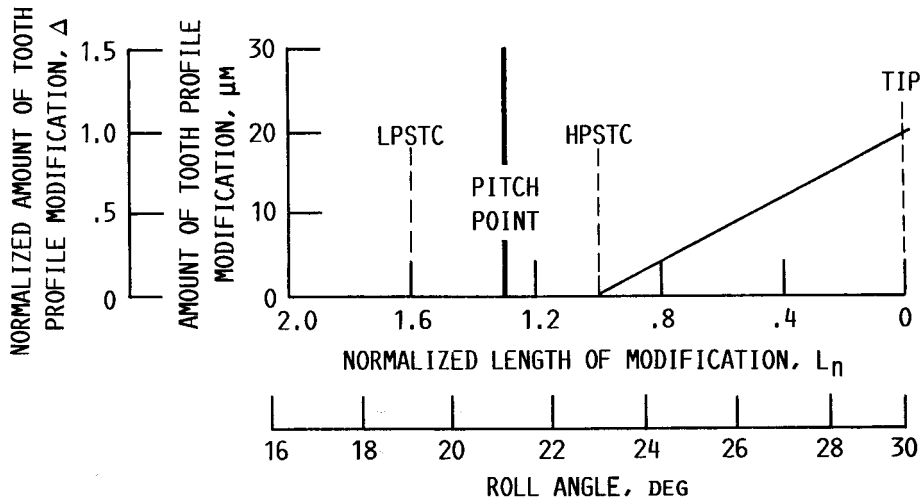

FIG. 1 COMPUTER MODEL OF SPUR GEAR SYSTEM



(A) GEAR TOOTH WITH MODIFIED TOOTH PROFILE



(B) SAMPLE TOOTH PROFILE MODIFICATION CHART

FIG. 2 EXAMPLE OF LINEARLY MODIFIED GEAR TOOTH

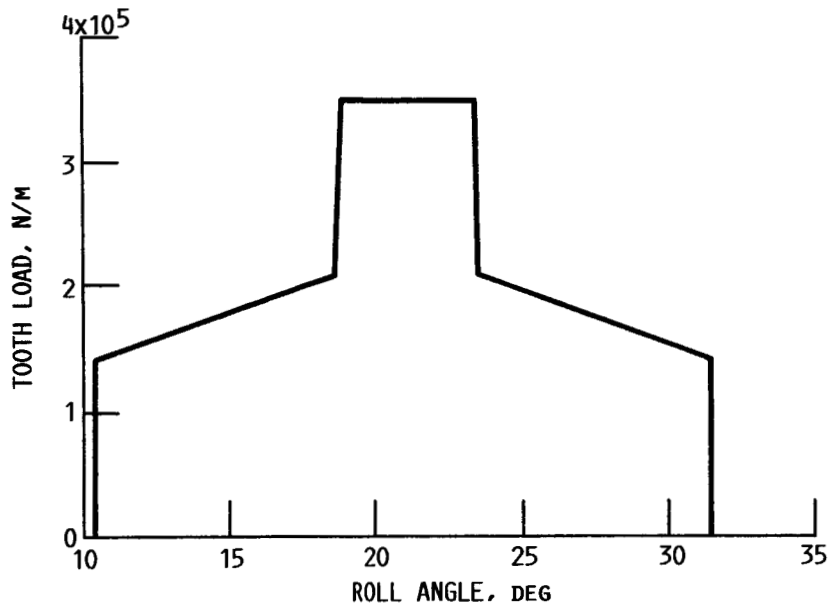
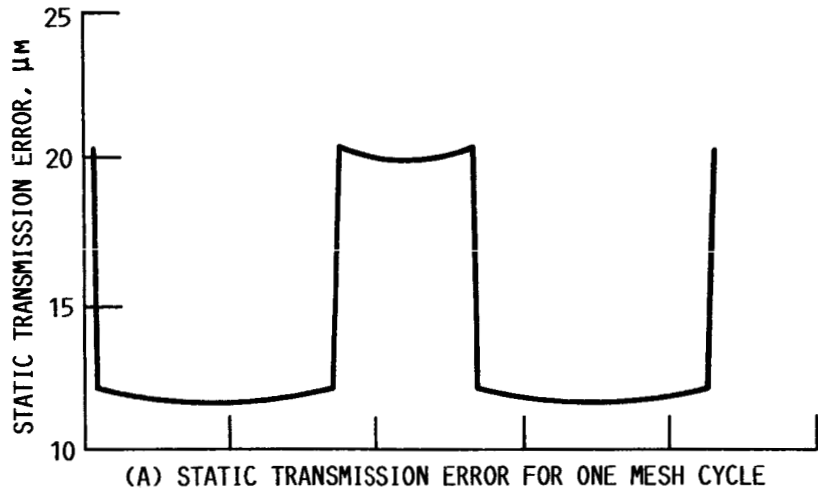

FIG. 3 SPUR GEAR PAIR UNDER DESIGN LOAD, NO PROFILE MODIFICATION

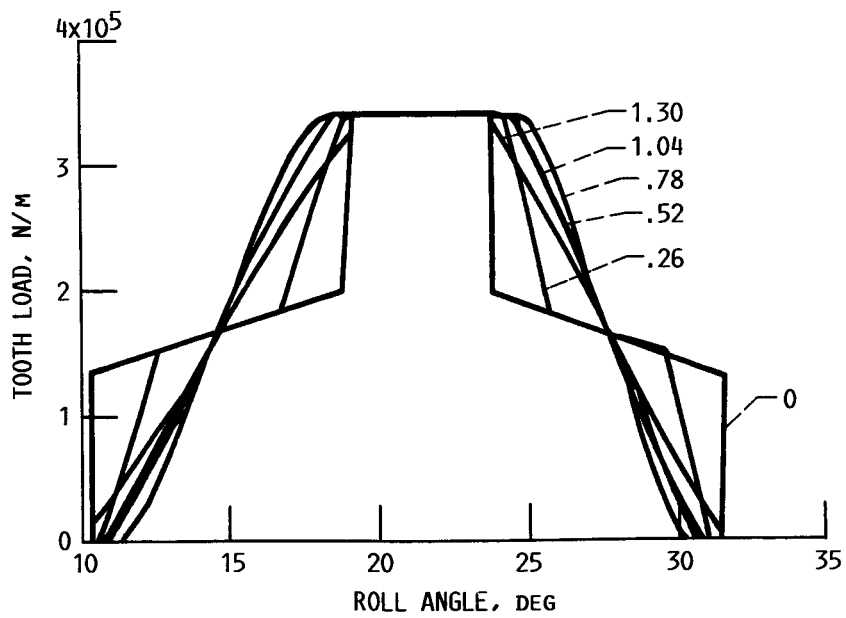
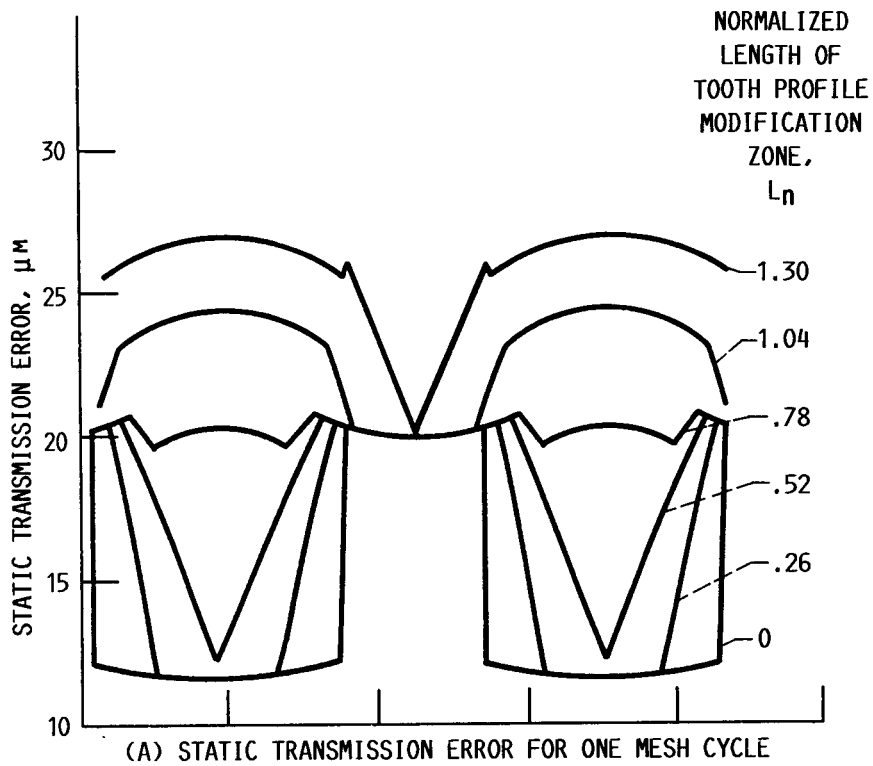
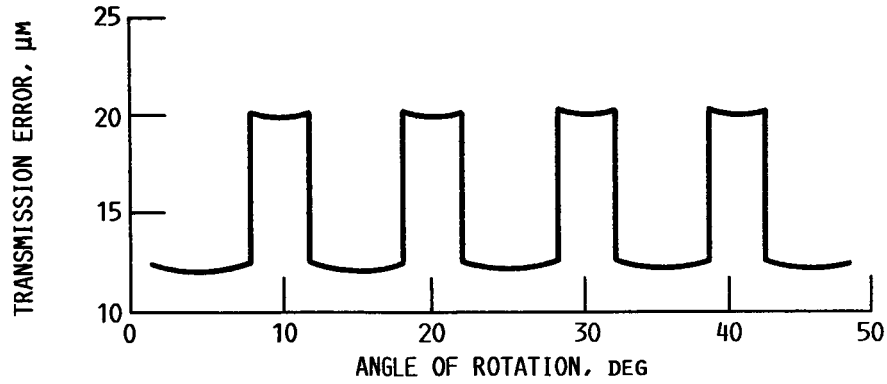
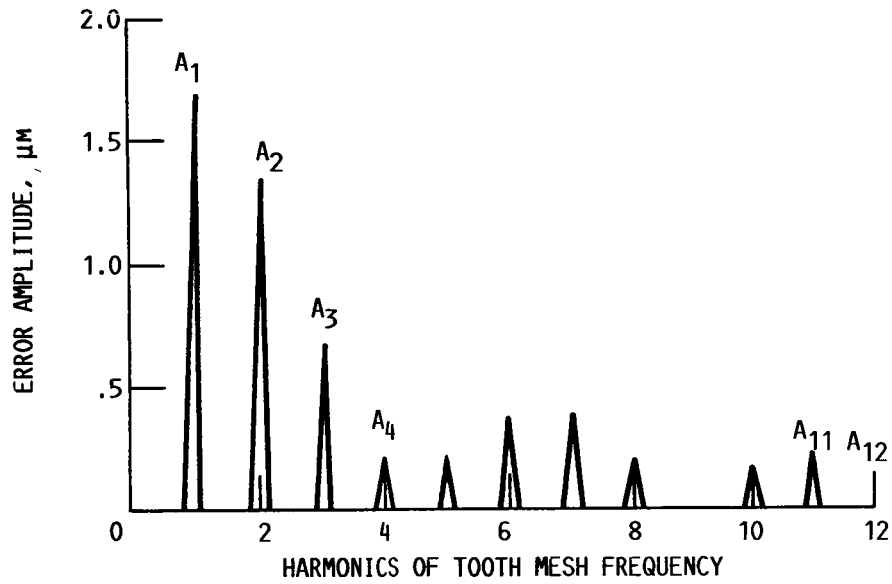

FIG. 4 EFFECT OF VARYING LENGTH OF PROFILE MODIFICATION ZONE AT CONSTANT AMOUNT OF PROFILE MODIFICATION, 1.25Δ



(A) STATIC TRANSMISSION ERROR



(B) FREQUENCY SPECTRUM OF STATIC TRANSMISSION ERROR

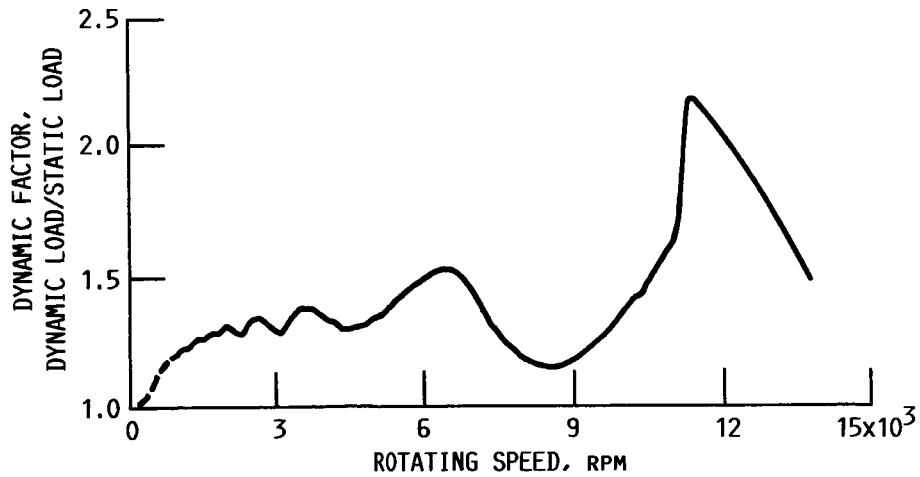

(C) DYNAMIC FACTOR AS FUNCTION OF ROTATING SPEED

FIG. 5 SPUR GEAR PAIR UNDER DESIGN LOAD - NO PROFILE MODIFICATION

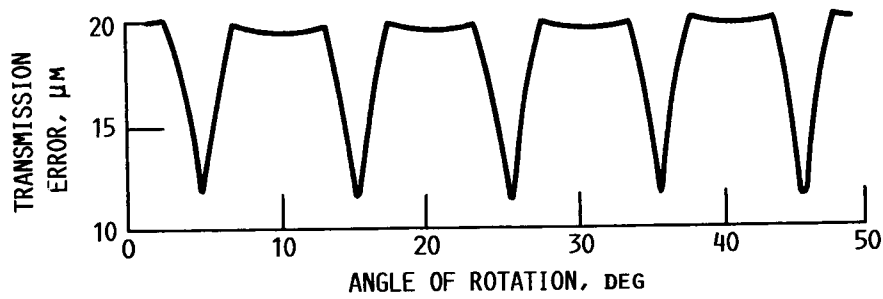

(A) STATIC TRANSMISSION ERROR

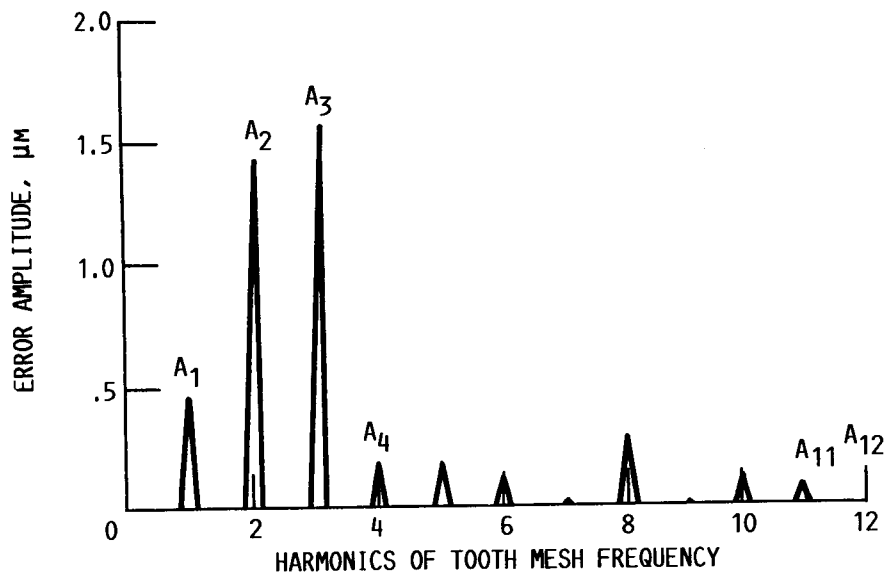

(B) FREQUENCY SPECTRUM OF STATIC TRANSMISSION ERROR

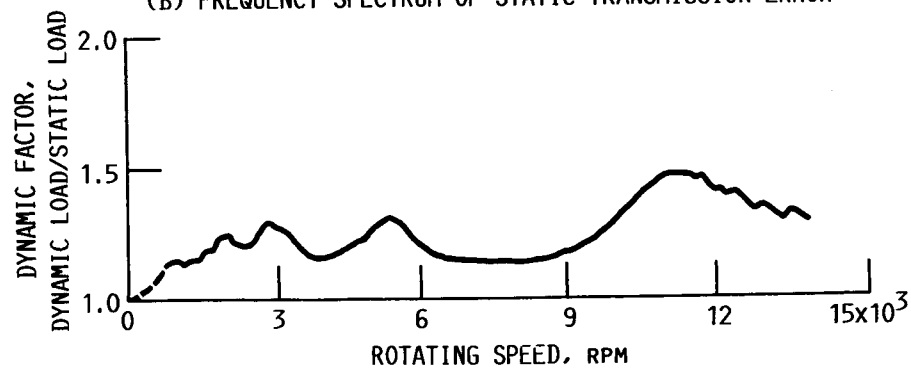

(C) DYNAMIC FACTOR AS FUNCTION OF ROTATING SPEED

FIG. 6 SPUR GEAR PAIR UNDER DESIGN LOAD - PROFILE MODIFICATION: AMOUNT, 1.25Δ ; LENGTH, $0.52 L_n$

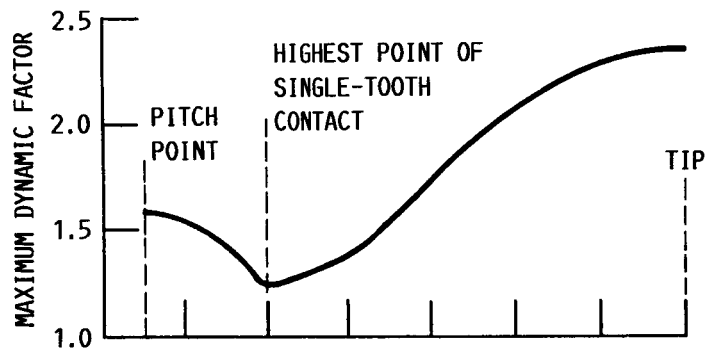

(A) GEAR TOOTH DYNAMIC FACTOR

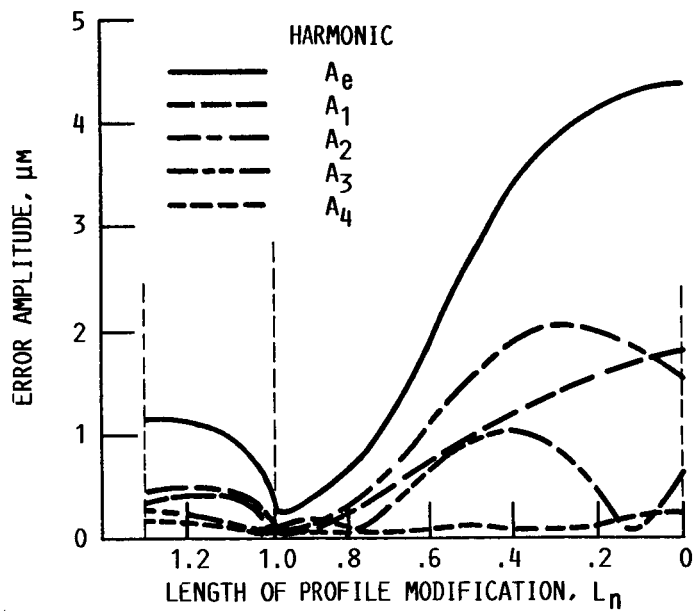

(B) TRANSMISSION ERROR FREQUENCY COMPONENTS AND EFFECTIVE ERRORS

FIG. 7 EFFECT OF VARYING LENGTH OF PROFILE MODIFICATION ZONE AT CONSTANT AMOUNT OF PROFILE MODIFICATION, 1.00Δ

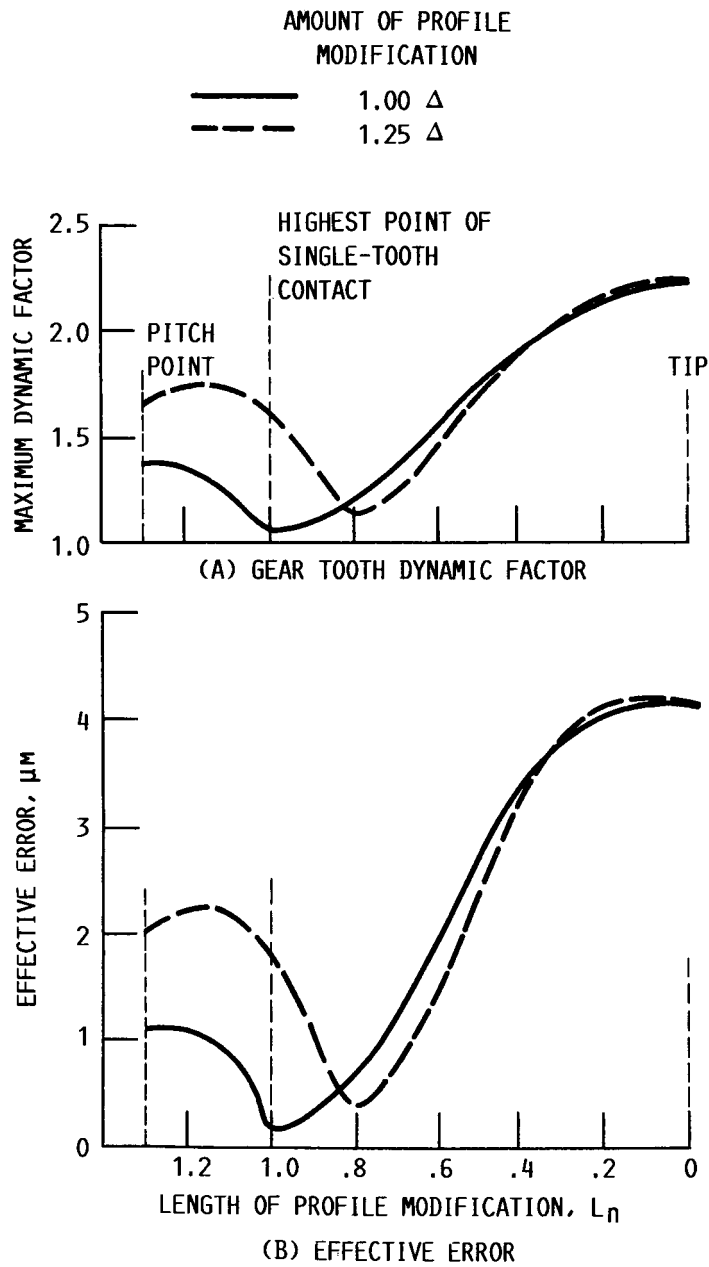

FIG. 8 EFFECT OF VARYING LENGTH OF PROFILE
MODIFICATION ZONE AT TWO AMOUNTS OF MODIFI-
CATION

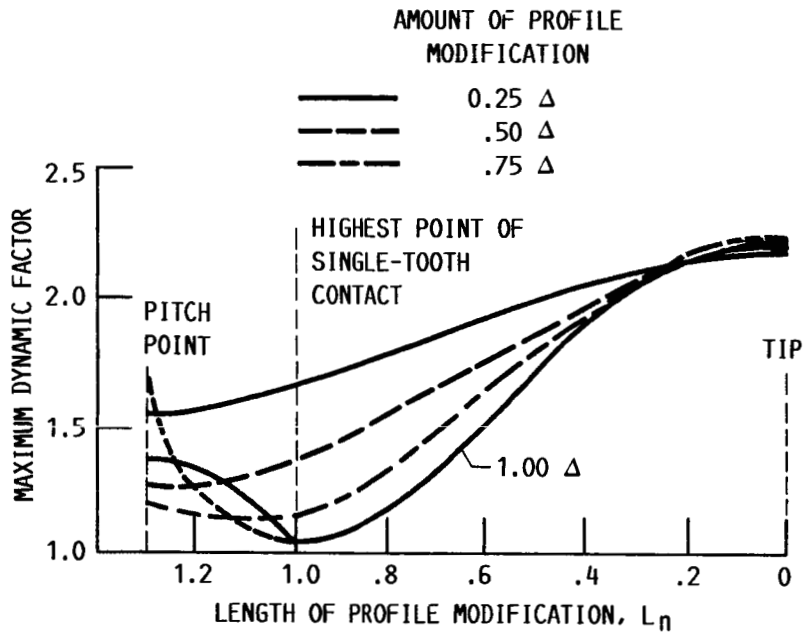

FIG. 9 DESIGN CHART FOR OPTIMAL LENGTH OF PROFILE MODIFICATION ZONE AT LESS THAN 1.00 Δ (EQUIVALENT TO OVERLOAD CONDITION AT 1.00 Δ)

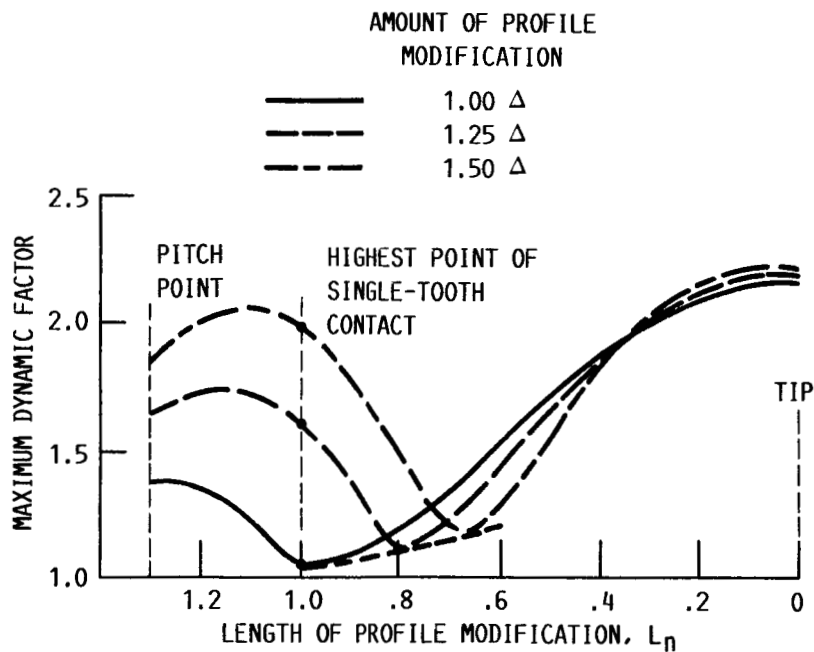
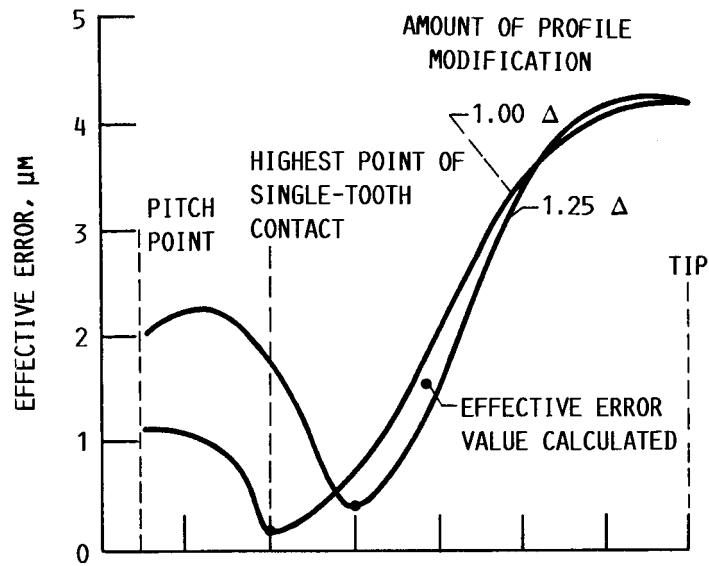
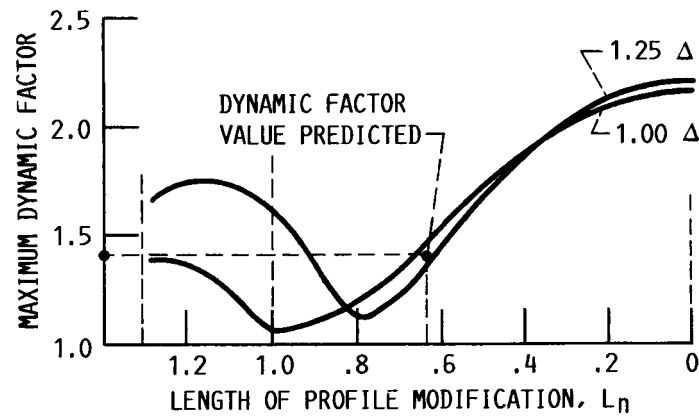

FIG. 10 DESIGN CHART FOR OPTIMAL LENGTH OF PROFILE MODIFICATION ZONE AT GREATER THAN 1.00 Δ (EQUIVALENT TO UNDERLOAD CONDITION AT 1.00 Δ)



(A) CALCULATED EFFECTIVE ERROR AT $L_n = 0.65$



(B) PREDICTION OF GEAR TOOTH DYNAMIC FACTOR AT $L_n = 0.65$

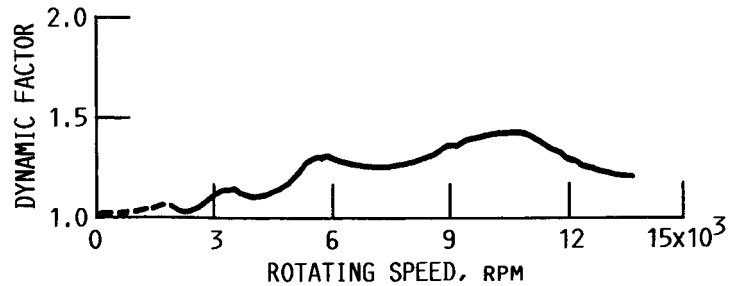

(C) CALCULATED DYNAMIC FACTOR FROM EQUATIONS OF MOTION

FIG. 11 EXAMPLE OF 1.00Δ ON ONE GEAR AND 1.25Δ ON MATING GEAR



Report Documentation Page

| | | | | | |
|--|--|---|--|---|--------------------------|
| 1. Report No. NASA TM-89901 | | 2. Government Accession No. | | 3. Recipient's Catalog No. | |
| 4. Title and Subtitle Profile Modification to Minimize Spur Gear Dynamic Loading | | | | 5. Report Date | |
| | | | | 6. Performing Organization Code | |
| 7. Author(s) Hsiang Hsi Lin, Dennis P. Townsend, and Fred B. Oswald | | | | 8. Performing Organization Report No. E-3597 | |
| | | | | 10. Work Unit No. 505-63-51 | |
| 9. Performing Organization Name and Address National Aeronautics and Space Administration Lewis Research Center Cleveland, Ohio 44135-3191 | | | | 11. Contract or Grant No. | |
| | | | | 13. Type of Report and Period Covered Technical Memorandum | |
| 12. Sponsoring Agency Name and Address National Aeronautics and Space Administration Washington, D.C. 20546-0001 | | | | 14. Sponsoring Agency Code | |
| | | | | | |
| 15. Supplementary Notes Prepared for the Design Engineering Technical Conference, sponsored by the American Society of Mechanical Engineers, Orlando, Florida, September 24-28, 1988. Hsiang Hsi Lin, Summer Faculty Fellow, presently at Memphis State University, Memphis, Tennessee 38152; Dennis P. Townsend and Fred B. Oswald, NASA Lewis Research Center. | | | | | |
| 16. Abstract <p>An analytical computer simulation program for dynamic modeling of low-contact-ratio spur gear systems is presented. The procedure computes the static transmission error of the gears operating under load and uses a fast Fourier transform to generate the frequency spectrum of the static transmission error at various tooth profile modifications. The dynamic loading response of an unmodified (perfect involute) gear pair was compared with that of gears with various profile modifications. Correlations were found between various profile modifications and the resulting dynamic loads. An effective error, obtained from frequency domain analysis of the static transmission error of the gears, gave a very good indication of the optimum profile modification to reduce gear dynamic loading. Design curves generated by dynamic simulation at various profile modifications are given for gear systems operated at various loads. Optimum profile modifications can be determined from these design curves for improved gear design.</p> | | | | | |
| 17. Key Words (Suggested by Author(s)) Spur gears; Dynamic load; Profile modifications; Equations of motion transmission error; Frequency analysis | | | | 18. Distribution Statement Unclassified - Unlimited Subject Category 37 | |
| 19. Security Classif. (of this report) Unclassified | | 20. Security Classif. (of this page) Unclassified | | 21. No of pages 21 | 22. Price* A02 |