

N 87 - 29153

P-70

ADVANCED LOCAL AREA NETWORK CONCEPTS

This technology development program for onboard Local Area Network (LAN) Concepts is based on a balance of academic studies of new protocol and topology through university grants together with in-house analysis and development of simulation tools. In-house simulation of LAN concepts is being backed up by analytic performance models. Another major element of this program is the constant review of the current outside literature on LAN analysis and the review of the Space Station Data System Architecture Study reports.

Development of a good model of the data traffic requirements for LANs onboard the Space Station is a driving problem in this work. A parameterized workload model is under development with its structure to be circulated for comments to other NASA researchers, the potential user community, and the system development contractors. An analysis contract has been started specifically to capture the distributed processing requirements for the Space Station and then to develop a top level model to simulate how various processing scenarios can handle the workload and what data communication patterns result.

Most of the studies are ongoing and the material presented here should be taken as only a sampling of the work. Attached are three distinct items: (1) a summary of the "Local Area Network Extensible Simulator II Requirements Specification", (2) excerpts from a recent Stanford University grant report by M. M. Nassehi, F. A. Tobagi, and M. E. Marhic, "Topological Design of Fiber Optic Local Area Networks with Application to Expressnet", and (3) as an appendix, from a Santa Clara University grant, Prof. T. J. Healy, "Coding and Decoding for Code Division Multiple User Systems," IEEE Transactions on Communications, April 1985.

PRECEDING PAGE BLANK NOT FILMED

PAGE 138 INTENTIONALLY BLANK

**ADVANCED
LOCAL AREA NETWORK
CONCEPTS**

**TERRY GRANT
NASA-AMES RESEARCH CENTER
APRIL 1985**

LOCAL AREA NETWORK EXTENSIBLE SIMULATOR
(LANES)

OBJECTIVE: TO PROVIDE A SIMULATION MODELING CAPABILITY OF ONBOARD LOCAL AREA NETWORK (LAN) CONCEPTS WITH APPLICATION TO THE SPACE STATION DATA SYSTEM

JUSTIFICATION: TO PROVIDE FOR DEVELOPMENT AND TECHNICAL INTERCHANGE OF VIABLE SPACE STATION LAN DATA SYSTEM CONCEPTS THROUGH SIMULATION MODELING

APPROACH: DEVELOP A VERSATILE MODEL OF LAN TECHNOLOGY THROUGH IMPLEMENTATION OF THE ISO-OSI NETWORK PARADIGM USING STATE-OF-THE-ART MEDIA ACCESS RULES AND PHYSICAL LAYER TOPOLOGIES.

TECH TRANSFER: DELIVER SIMULATION CAPABILITY FOR EXPERIMENTATION THROUGH REMOTE ACCESS OF LANES VIA TELENET AS INDIVIDUAL MODELS ARE DEVELOPED:

- 0 NASA CENTERS
- 0 INDUSTRY
- 0 UNIVERSITIES

INTERNATIONAL STANDARDS ORGANIZATION—
OPEN SYSTEMS INTERCONNECT
(ISO—OSI)
REFERENCE MODEL

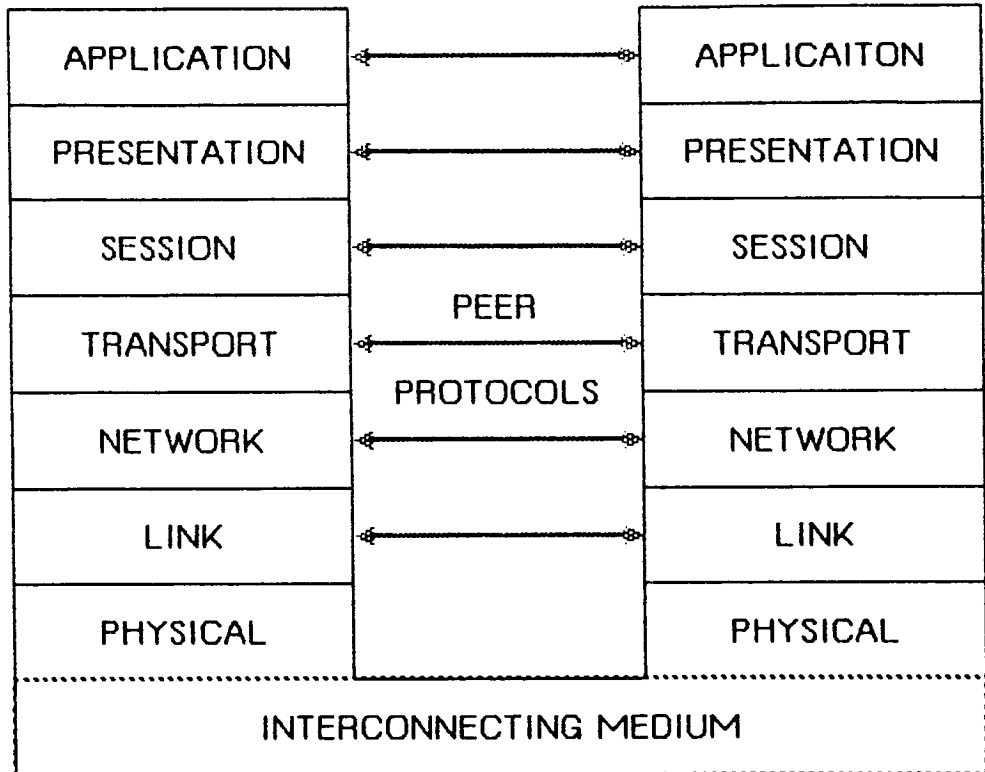

LOCAL AREA NETWORK EXTENSIBLE SIMULATOR

VERSION I

ISO-OSI MODEL

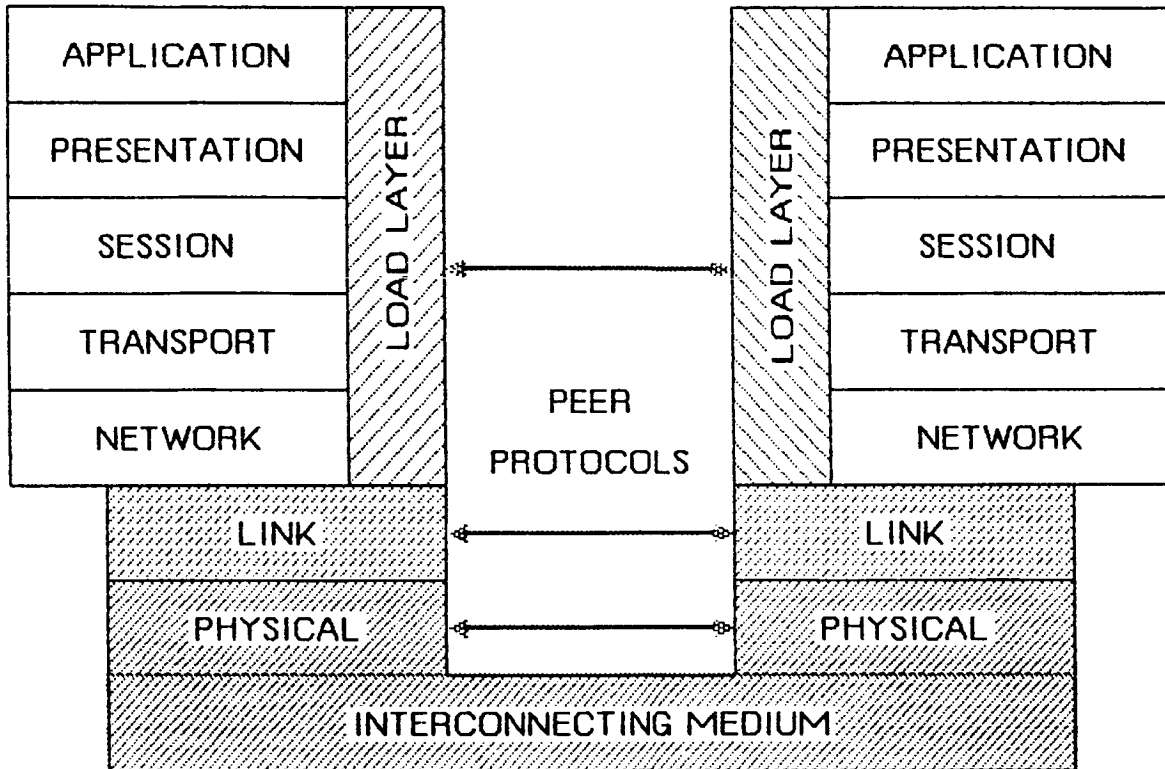

PHYSICAL LAYER - PASSIVE STAR

LINK LAYER - CSMA/CD/TS (FODS) PROTOCOL

LOAD LAYER - SINGLE MESSAGE SIZE,

USER DEFINED MESSAGE INTERARRIVAL TIME

USER DEFINED MESSAGE ABSORPTION TIME

LOCAL AREA NETWORK EXTENSIBLE SIMULATOR

VERSION II

ISO-OSI MODEL

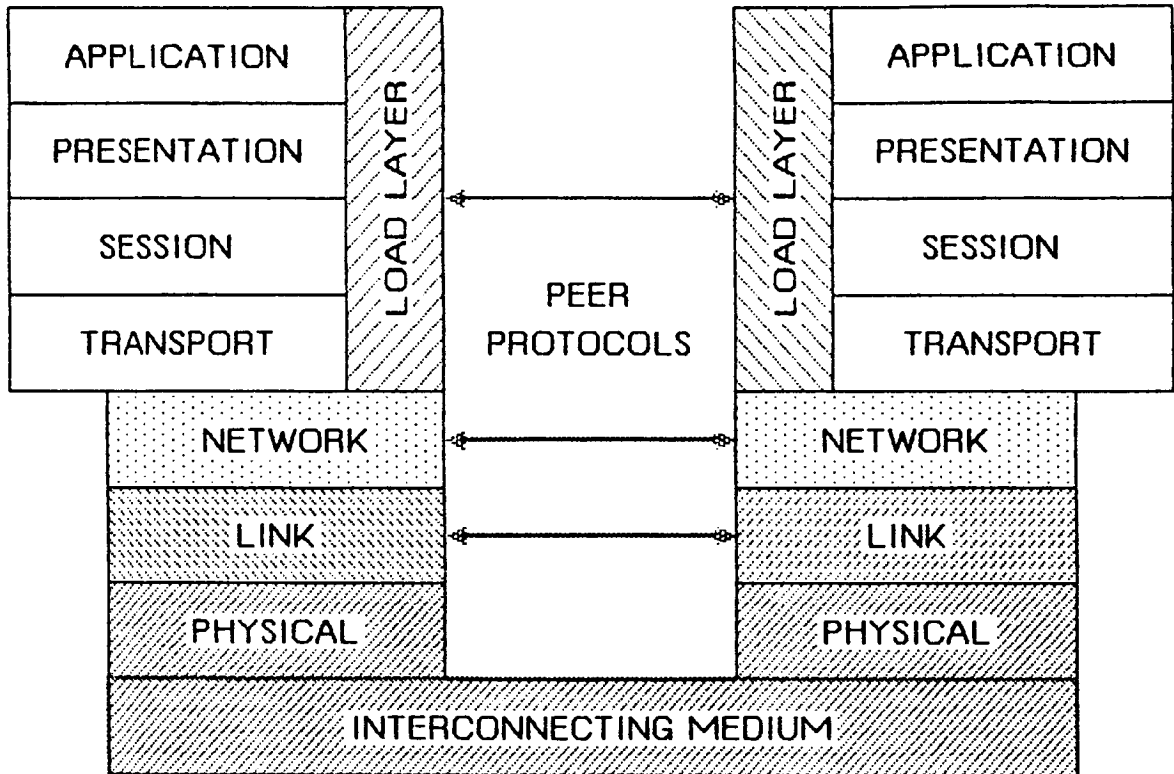

PHYSICAL LAYER

- STAR OR TOKEN PASSING RING

LINK LAYER

- FDS OR FDDI TOKEN RING MEDIA ACCESS CONTROL
(ANSI X3T9/84-X3T9.5/883-16 Rev. 7.2)

NETWORK LAYER

- USER DEFINED MESSAGE BUFFERING

LOAD LAYER

- USER DEFINED MESSAGE DESCRIPTORS

NETWORK STATION
DATA TRANSMISSION, RECEPTION, AND STORAGE

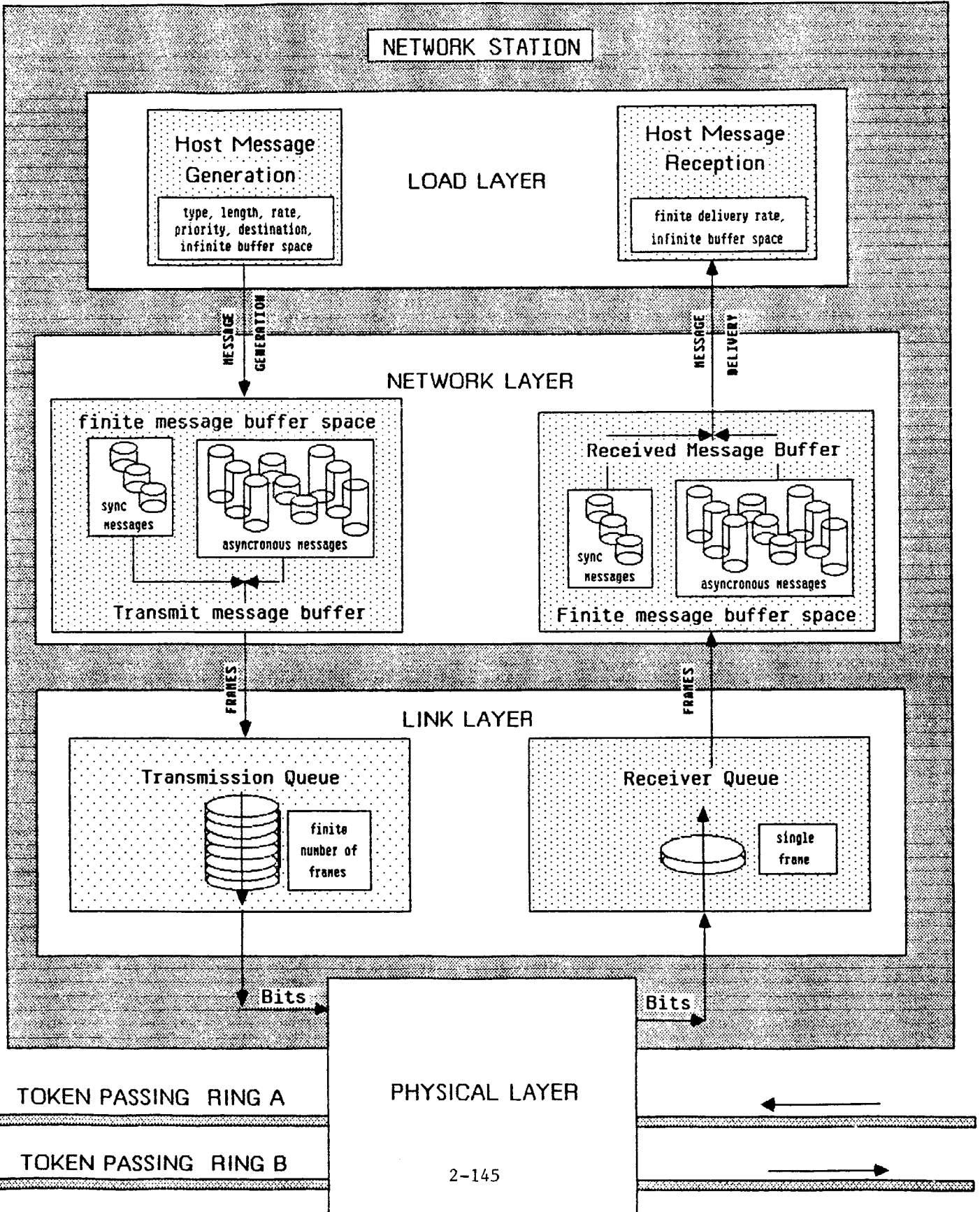

LANES

USER INTERFACE

THE USER INTERFACE ALLOWS THE EXPERIMENTER TO:

- 0 CONSTRUCT ALTERNATIVE NETWORKCONFIGURATIONS
- 0 SELECTIVELY COLLECT AND ANALYSE DATA
- 0 CONSTRUCT AND RUN MULTIPLE SEQUENTIAL EXPERIMENTS

THE USER INTERFACE PROVIDES:

- 0 USE OF "MENU" SYSTEM TO MANIPULATE LANES PARAMETERS
- 0 AN ON-LINE "HELP" UTILITY
- 0 A HARDCOPY USER'S GUIDE

LANES
DATA COLLECTION AND ANALYSIS SERVICE

COLLECTION SERVICES: STATION LEVEL

- 0 NUMBER OF OCCURRANCES OF ELEVEN PARAMETERS
- 0 MAXIMUM, MINIMUM, AND MEAN VALUE OF ELEVEN PARAMETERS
- 0 INTERVAL BASED COLLECTION OF TWENTY-ONE PARAMETERS
- 0 EVENT TIME TRACES OF ALL STATION ACTIVITY

COLLECTION SERVICES: NETWORK LEVEL

- 0 NUMBER OF OCCURRANCES OF ELEVEN PARAMETERS
- 0 MINIMUM, MAXIMUM AND MEAN VALUES OF TEN PARAMETERS
- 0 INTERVAL BASED COLLECTION OF TWENTY-ONE PARAMETERS

ANALYSIS SERVICES:

- 0 NETWORK THROUGHPUT EFFICIENCY
- 0 TOTAL BUS UTILIZATION

Topological Design of Fiber Optics Local Area Networks With Application to Expressnet*

by

M. Mehdi Nassehi, Fouad A. Tobagi and Michel E. Marhic[†]

Computer Systems Laboratory

Department of Electrical Engineering

Stanford University, Stanford, CA 94305

Abstract

The use of fiber optics technology as a transmission medium in Local Area Networks (LAN's) brings about primarily three benefits: high bandwidth, immunity to electromagnetic interference, and light weight. But in (multi-tapped) passive broadcast bus configurations, the characteristics of certain fiber optics components that are needed, (such as reciprocity and excess loss in optical taps,) place severe constraints which must be taken into account in the topological design of such networks. These constraints manifest themselves in the form of a limitation on the maximum number of stations that a particular network configuration can support, given the components' characteristics and special requirements introduced by the access scheme. In this paper we provide a general and unified approach to the power budget analysis and optimization problem, and apply the technique to the study of a number of interesting high-performance LAN's, among others, Expressnet.

*This work was supported by the National Aeronautics and Space Administration under Contracts NASA-NAG-2-292 and NASA-NAGW-419. M. Mehdi Nassehi is on an IBM Graduate Fellowship.

†On leave from Northwestern University, Dept. of Electrical Engineering and Computer Science, Evanston, IL, 60201.

VI. Conclusion

A number of configurations for fiber-optics implementation of Expressnet, and other related networks, were presented. Based on a unified approach, the maximum number of stations N_{\max} that each of these configurations can support was computed.

For local area networks such as Expressnet, it proved useful to make a distinction between the *connectivity* requirement needed for broadcast communication and the *linear ordering* requirement needed for access control. Such a distinction allowed us to consider configurations consisting of two separate subnetworks: one called the *data subnetwork* satisfying the connectivity requirement, and the other called the *control subnetwork* satisfying the linear ordering requirement. The topology of the control subnetwork is inherently *linear*. When the topology of the data (collection) subnetwork is linear, then the latter automatically satisfies the linear ordering requirement and a separate control subnetwork becomes unnecessary.

The numerical results have shown that, with multimode fibers, high-cost components, and uniform optimization of couplers, all fiber-optics configurations implementing Expressnet can support more than 50 stations, with the exception of the all-linear configuration (i.e., linear collection and linear distribution) which can support 30 stations. For configurations in which the *data (collection) subnetworks* do not have a linear topology (i.e., tree, star, or compound), the number of stations that these data subnetworks can support (discarding the control subnetwork) far exceed 50, reaching several hundreds. The limitation of 50 to 70 stations, depending on the data rate (50 Mbps to 200 Mbps,) is then imposed by the linear control subnetwork. For components with mid-range parameters, only data subnetworks with the star topology and compound topologies (with large funneling width) can support large numbers (also in the hundreds). All others including the linear control subnetwork can hardly reach 10. Low cost components in all cases are totally inappropriate.

The numerical results have also shown that individual optimization substantially improves the number of stations, doubling it in many cases (obviously, with the exception of the star network where no 2×2 coupler is used.) It was observed that the singlemode fiber technology does not outperform the multimode case, despite the lower excess-loss of couplers in the former. This is due to the fact that the amount of optical power that can be injected into a singlemode fiber is significantly smaller than what can be injected into a multimode fiber.

From these results, it is clear that there are configurations in which one can support a significant number of stations, and that the main limitation comes from the linear ordering requirement imposed by the scheme. This suggests that the use of repeaters on the (fiber-optics) linear control subnetwork may be necessary to increase the maximum number of stations. This also suggests that, if one uses a medium other than fiber-optics (such as twisted-pair and coaxial cable) to implement the control subnetwork, then one could support a much larger number of stations than indicated.

The numerical results obtained for the data subnetworks, (excluding the control subnetwork,) are useful as they pertain to networks based on demand assignment access schemes that do not have the linear ordering requirement. Examples are PODA [34] and IIAM [35] both of which achieve a high utilization of bandwidth by employing a reservation technique. Unfortunately these schemes tend to be more complex than the Expressnet access algorithm, and thus more costly to implement.

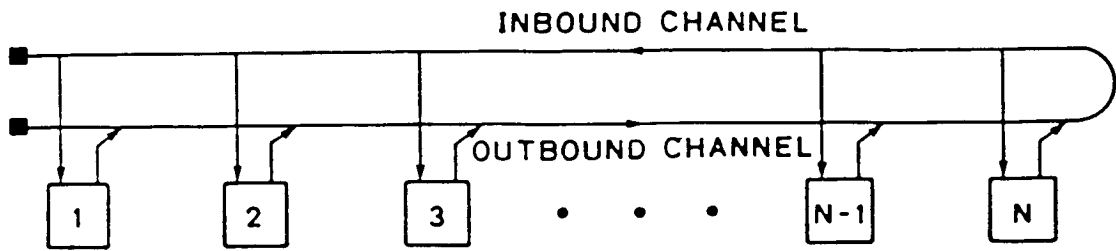

Fig. 2 The folded bus structure.

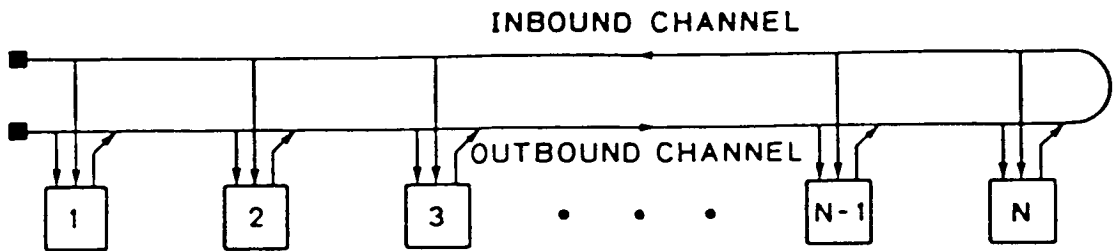

Fig. 3 The folded bus structure with sense taps on the outbound channel.

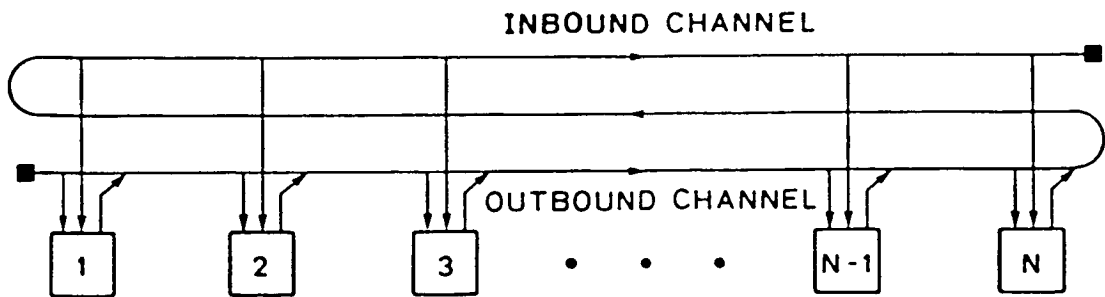

Fig. 4 UBS configuration used with Expressnet.



(a) Connector



(c) Coupler C



(b) Joint

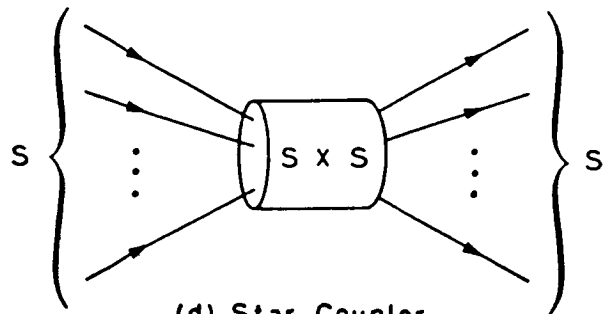

(d) Star Coupler

Fig. 5 Fiber-optics components: (a) a connector, (b) a joint, (c) a coupler, and (d) an $S \times S$ star coupler.

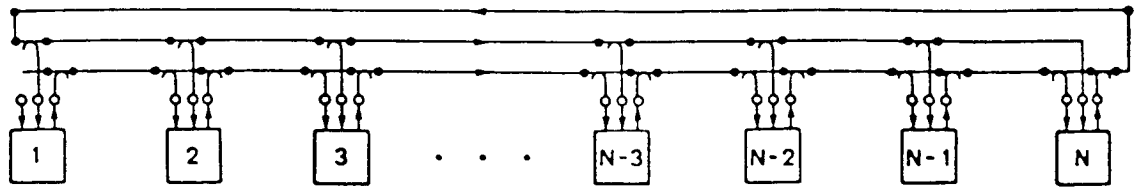

(a)

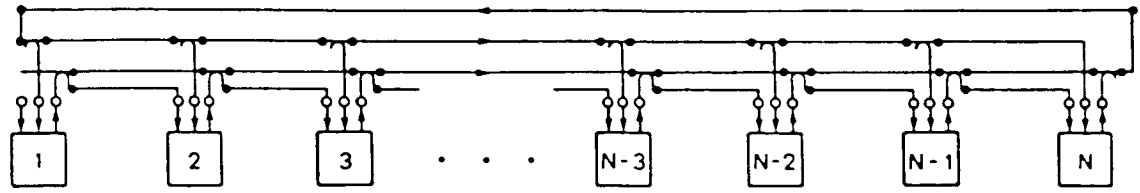

(b)

Fig. 6 Linear configuration (L).

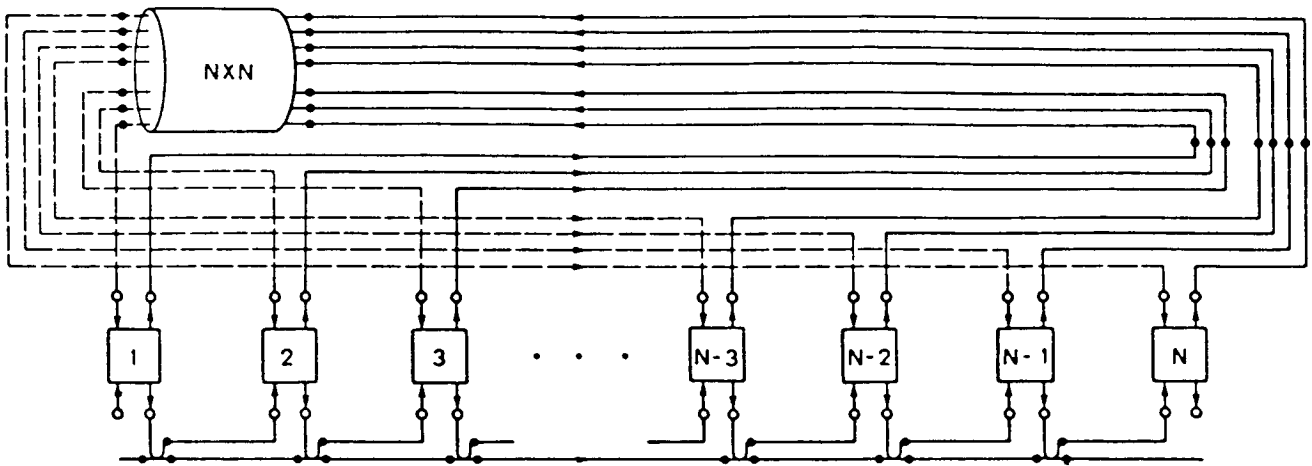

Fig. 7 Star configuration (S/C).

References

- [1] R. M. Metcalfe and D. R. Boggs, "Ethernet: Distributed packet switching for local computer networks," *Communications of the ACM*, Vol. 19, No. 7, July 1976, pp. 395-403.
- [2] *IEEE Project 802 Local Area Network Standards*, Draft D 802.4, Token-Passing Bus Access Method and Physical Layer Specification, IEEE Computer Soc., Silver Spring, MD, 1983.
- [3] W. Bux, "Local-Area Subnetworks: A Performance Comparison," *IEEE Transactions on Communications*, Vol. COM-29, No. 10, October 1981, pp. 1465-1473.
- [4] M. C. Hudson and F. L. Thiel, "The Star Coupler: A unique interconnection component for multimode optical waveguide communications systems," *Applied Optics*, Vol. 13, No. 11, November 1974, pp. 2540-2545.
- [5] A. F. Milton and A. B. Lee, "Optical access couplers and a comparison of multiterminal fiber communication systems," *Applied Optics*, Vol. 15, No. 1, January 1976, pp. 244-252.
- [6] D. E. Altman and H. F. Taylor, "An eight-terminal fiber optics data bus using tee couplers," *Fiber Integrated Opt.*, Vol. 1, 1977, pp. 135-152.
- [7] F. Auracher and M.-M. Witte, "Optimized layout for a data bus system based on a new planar access coupler," *Applied Optics*, Vol. 16, No. 12, December 1977, pp. 3140-3142.

- [8] C. A. Villarruel, R. P. Moeller and W. D. Burns, "Tapped tee single-mode data distribution system," *IEEE Journal of Quantum Electronics*, Vol. QE-17, No. 6, June 1981, pp. 941-946.
- [9] R. V. Schmidt, E. G. Rawson, R. E. Norton, S. B. Jackson and M. D. Douglas, "Fibernet II: A Fiber Optic Ethernet", *IEEE Journal on Selected Areas in Communications, Special Issue on Local Area Networks*, Vol. SAC-1, No. 5, November 1983, pp. 702-711.
- [10] J. O. Limb, "On Fiber Optic Taps for Local Area Networks," in *Proceedings of International Conference on Communications*, Amsterdam, May 1984, pp. 1130-1136.
- [11] M. Fine and F. A. Tobagi, "Demand Assignment Multiple Access Schemes in Broadcast Bus Local Area Networks," *IEEE Transactions on Computers*, Vol. C-33, No. 12, December 1984, pp. 1130-1159.
- [12] F. A. Tobagi, F. Borgonovo and L. Fratta, "Express-net: A high-performance integrated-services local area network," *IEEE Journal on Selected Areas in Communications*, Vol. SAC-1, No. 5, November 1983, pp. 898-912.
- [13] J. O. Limb and C. Flores, "Description of Fasnet, a unidirectional local area communications network," *Bell Systems Technical Journal*, Vol. 61, No. 7, September 1982, pp. 1413-1440.
- [14] M. Gerla, C. Yeh and P. Rodrigues, "A token protocol for high speed fiber optics local networks," in *Proceedings Optical Fiber Communication Conference*, New Orleans, Louisiana, February 1983.

- [15] P. Rodrigues, L. Fratta and M. Gerla, "Token-less protocols for fiber optics local area networks," in *Proceedings of International Conference on Communications*, Amsterdam, May 1984, pp. 1150-1153.
- [16] M. A. Marsan and G. Albertengo, "Integrated voice and data network," *Computer Communications*, Vol. 5, No. 3, June 1982.
- [17] M. Gerla, P. Rodrigues and C. Yeh, "BUZZ-NET: A hybrid random access/virtual token local network," in *Proceedings Globecom '83*, San Diego, CA, December 1983.
- [18] T. Li, "Optical Fiber Communication - The State of the Art," *IEEE Transactions on Communications*, Vol. COM-26, July 1978, pp. 946-955.
- [19] Canstar Communications, Model PCS.
- [20] M. E. Marhic, "Combinatorial star couplers for singlemode optical fibers" in *Proceedings of FOC/LAN*, September 1984, pp. 175-179.
- [21] J. E. Midwinter, "First-Generation Trunk Transmission Systems: Capabilities and Limitations," *IEEE Journal on Selected Areas in Communications*, Vol. SAC-1, April 1983, pp. 381-386.
- [22] N. L. Rhodes, "Interaction of Network Design and Fiber Optic Component design in Local Areas Networks", *IEEE Journal on Selected Areas in Communications*, Vol. SAC-1, No.3, April 1983, pp.489-492.
- [23] K. Ogawa, "Considerations for Optical Receiver Design," *IEEE Journal on Selected Areas in Communications*, Vol. SAC-1, No. 3, April 1983, pp. 533-540.
- [24] *IEEE Spectrum*, January 1985, p. 57.

- [25] Lasers and Applications, September 1984, p. 70.
- [26] Furukawa fusion splicer, model FITEL S-141.
- [27] Plessey HRR7831.
- [28] ADC Magnetic Controls Co., Model PFC.
- [29] NEC (Nippon Electric Col., Ltd.), Models OD-8601-8604 (type C).
- [30] Spectra Diode Labs, Model SDL-2410-D2 (50mW from a 100 μ m core pigtail).
- [31] P. M. Kopera, H. H. A. Krueger, V. J. Tekippe, and D. L. Wuensch, *Proceedings of SPIE*, Vol. 479, p. 9 (1984).
- [32] Fibernetics, 90 Glenn Way, Unit 12, Belmont, CA 94002.
- [33] Canadian Instrumentation and Research Ltd., Research Model VC.
- [34] Laser Focus/Electro-Optics, January 1985, p. 85.
- [35] I. M. Jacobs, R. Binder and E. V. Hoversten, "General purpose packet satellite networks," in *Proceedings of IEEE*, Vol. 66, No. 11, November 1978.
- [36] K. Hanson, W. Chou and A. Nilsson, "Integration of Voice, Data, and Image Traffic on a Wideband Local Network," in *Proceedings of Computer Network Symposium*, December 1981.