

N87-29881

ANATOMY OF A BEARING TORQUE PROBLEM

Damon D. Phinney*

INTRODUCTION

In the early 1970s, Ball Aerospace Systems Division developed an antenna despinn drive for the Messerschmitt Boelkow Blohm (MBB) solar science satellite HELIOS. This paper discusses a problem with high bearing drag torque that was encountered on the two flight models of this drive, after successful tests were completed on twelve bearings, an engineering model, and the qualification unit.

HELIOS was spin-stabilized at 60 RPM and was to be launched into a highly elliptical orbit which would take it 70 percent of the distance to the sun and then back within a million km of Earth, two times a year. The Despin Drive Assembly (DDA) mission was to point a parabolic antenna continuously toward Earth during the entire orbit. The shaft of the inside-out DDA was fixed to the spacecraft, supporting the antenna feed at its outboard end, while the antenna was attached to the housing. The specified DDA temperature range was -50°C to 60°C , and minimum lifetime was to be 18 months.

Our torque troubles occurred at the low end of the temperature range. The problem was insidious because it offered no clues of its existence in our usual tests until we went to low temperature, and the measures taken to correct it gave no indication of their effectiveness at normal temperatures.

DESCRIPTION OF DESPIN DRIVE ASSEMBLY

A flight DDA is pictured from the outside, with its mounting end up, in Figure 1, with internal details illustrated in Figure 2. Salient construction features that are discussed in the following account are shown in greater detail in Figure 3. They are:

- A three-piece shaft assembly, consisting of a 7075-T652 aluminum tube 7.8 in. long with 6Al-4V titanium stubshafts at each end. Bearing journals were on the stubshafts, whose function was to isolate the bearings from the high expansion rate of the aluminum tube. The stubshaft at the left end of Figure 3 has 16 studs on a flange outside the bearing, by which the DDA was mounted on the spacecraft.
- A three-piece housing assembly. The main housing was aluminum, with an 8-in. ribbed titanium plate at one end, and a short cylindrical titanium member at the other. The titanium pieces carried the bearing outer rings, isolating them from the aluminum member.

* Ball Aerospace Systems Division, Boulder, Colorado

- The aluminum shaft and housing were made from bar stock. The titanium end plate was probably made from 1 in. plate. (The drawing is ambiguous and production records are no longer available.) Other titanium pieces were made from bar stock.
- Two angular contact ball bearings were spaced 6.4 in. apart with outer race thrust shoulders facing each other. All bearing rings were slight interference fits except for the outer race of the right hand bearing. This was slip-fitted and acted on by a set of coil springs with a force of 5 lb. The springs were in a carrier machined to length at assembly to produce an end play of 0.0055/0.0065 in. Because of the mix of aluminum and titanium pieces in the shaft and housing, the end play would be reduced by 4 mils at -50°C.
- The 440C bearings were lubricated with a thin film of MoS₂ approximately 1/4 micron thick, and had inner-land-riding Rulon-A separators with full cylindrical pockets. The normal ball complement was reduced from 42 to 38 to provide additional separator material between pockets and increased dimensional stability.

Additional DDA features, for information, include:

- Non-redundant resolver-commutated brushless DC motor
- Magnetic pickups for rate and position
- An electronics assembly with motor drive circuitry, magnetic pickup output conditioning and a motor current feedback circuit. MBB closed the rate and position loops.

EARLY EXPERIENCE AND FLIGHT UNIT PROBLEM

DDA requirements included operation between -50°C and 60°C (-60°C and 75°C for qualification) with a maximum drag torque of 5 oz-in. In addition to the bearings, the only significant drag source was motor hysteresis (1.3 oz-in.).

To confirm bearing lubrication, a thermal vacuum life test on six bearing pairs had been run at 60 RPM for 18 months. Temperatures were -35°C, 10°C, and 60°C. Torques varied from 0.5 to 1.5 oz-in. with brief excursions to 2.5 oz-in. on two sets at 22°C.

An 18-month thermal vacuum life test had also been conducted on an engineering model DDA at 60 RPM and temperatures of -40°C, 22°C, and 50°C. After some fixturing problems were corrected, drag torque varied between 2 and 4 oz-in. There were two brief excursions as high as 8 oz-in. at 22°C and 120 RPM while we were catching up after some down-time.

The qualification unit had shown drag torques of 6.4 and 4.5 oz-in. at -60°C and 75°C. The 6.4 oz-in. reading, although above the 5 oz-in. limit,

was rationalized away on the basis of a probable adverse temperature gradient (housing warmer than shaft) unlikely to occur during flight. An excessive gradient would have completely eliminated end play and caused an increase in bearing load.

With this favorable experience preceding acceptance tests of the two flight DDAs, we were rudely surprised when drag torque climbed to 20 oz-in. on the first unit while it was being taken down to -50°C .

TESTS TO OBTAIN MORE INFORMATION

It took nearly three months to find out how to fix the drive and implement the changes. We ran 29 low-temperature tests on the DDA, several tests on the bearings by themselves, and distortion measurements at low temperature on several components, as well as making up special test samples of two of the drive parts involved.

The first step was to measure torque vs. temperature with the drive cooling down. These data were not taken during acceptance testing. The rotating housing was instrumented and the cooling rate, in soft vacuum, was adjusted so that the housing followed the shaft within 10°C . Torque was determined from motor current.

Curve 1 on Figure 4 shows results with the DDA in its normal mounting position, shaft vertical and big end down. In this position, the lower bearing carries the weight of the drive housing (several lb) and also the bearing preload force of 5 lb. Although this test indicates a peak torque of only 13 oz-in. at -50°C , and suggests that limiting the housing-to-shaft temperature gradient was helpful, it clearly shows a problem.

Curve 2 on Figure 4 gives results with the drive inverted. Torque exceeded 20 oz-in. at -56°C . In this position, the bearing now on top is essentially unloaded and the bottom bearing is subject to the preload force only, with the housing weight close to the preload spring force. This removes approximately 10 lb of total bearing load and explains the reduction in drag torque at room temperature, correlating well with results of bearing torque vs. preload tests. The shift in the knee of the torque curve to a lower temperature is not explained. As will be seen, our corrective actions were taken at the big end of the drive where it was usually attached to the mount, which was also a cooling plate. With the sensitive end of the shaft no longer attached to the cooling plate, it may not be surprising that response to low temperature is somewhat different.

Bearing Tests

The next step was to check out the bearings themselves. The inner land-riding separators were Rulon-A, which has a coefficient of thermal expansion (CTE) of $32 \times 10^{-6}/^{\circ}\text{F}$, more than five times the bearing ring CTE. Furthermore, the material had shown a tendency to go slightly out-of-round after machining.

We had land clearance sufficient to accommodate the CTE difference and some out-of-round, and used a thermal stabilizing process to minimize machining distortion. Additionally, life test results had demonstrated satisfactory separator design. Nevertheless, we tested our spare separator stock to find ones that had the least drag torque down to -60°C and retrofitted them into the flight DDA bearings. These bearings were then tested by themselves in a fixture, showing a torque of 1.6 oz-in. at -60°C .

If high torque occurred with these bearings in the DDA, it would not be due to the bearings by themselves.

DDA Retest in CO_2 Gas-Cooled Cold Chamber

With the reworked bearings back in the DDA, a cold test was performed in an atmospheric pressure cold chamber, using CO_2 gas as the coolant, to speed up the test and minimize temperature gradients. All subsequent tests were run in the cold chamber until the problem was solved.

This test indicated high torque again (Curve 3 on Figure 5) and proved that there was a problem other than in the bearings.

Bearing Slip-Fit Tests

The upper bearing outer race was a nominal 0.001 in. loose in its housing. CTEs for 440C steel and 6 Al-4V titanium are 5.8 and $4.8 \times 10^{-6}/^{\circ}\text{F}$ respectively. Therefore, the 3.88 in. bearing ring should have become 0.5 mil looser as the unit cooled down. Loss of the slip fit should not have been the problem unless severe out-of-roundness was taking place, or unless the bearing ring was much warmer (30°C) than the housing.

This DDA had 0.0061 in. of end play measured at room temperature. The aluminum shaft was 7.8 in. long and the aluminum housing was 3.8 in. long. Titanium parts and the steel bearings made up the other 4 in. Because of the difference in CTEs for aluminum and titanium (4.8 and $12.7 \times 10^{-6}/^{\circ}\text{F}$), end play would be reduced about 4 mils at -50°C , assuming uniform temperature. If the shaft cooled faster than the housing, another 0.5 mil would be lost for every 10°C of temperature gradient. In the cold box, with cooling by circulating CO_2 gas, the housing should have been colder than the shaft and loss of end play should not have been the problem.

Nevertheless, a simple fixture was made with which we could manually feel end play with the drive stopped. In the first test, we could no longer detect any play at -25°C and torque was up to 8 oz-in. A new preload ring giving 9 mils of end play was installed. Now some play was still detectable at -33°C but torque had reached 10 oz-in. (see Curve 4, Figure 5). Since all subsequent tests will be run with increased end play, Curve 4 will be used as a baseline for evaluating effects of changes.

These tests showed that loss of end play or sliding fit of the upper bearing was not the problem. The unit was then tested upside down with increased

end play. Torque was only 3.5 oz-in. at -50°C (see Curve 5, Figure 5). Comparing results with Curve 2, Figure 4, when the drive was upside down in a thermal vacuum test, it appears that increased end play and/or the difference in cooling method caused a major improvement. We did not determine the reasons for this improvement.

Torque Noise Determination

For the preceding test, we had started to record the motor current signal. The drive was being run open-loop, with a fixed voltage across the motor. Voltage was manually adjusted from time to time, as average torque changed, to maintain a nominal 60 RPM.

In this operating mode, when a transient torque rise occurs, the drive slows down. The lower speed causes reduced back EMF, permitting more current to flow. Since motor torque is proportional to current, operation is basically stable. Furthermore, the motor current trace gives a direct indication of the frequency of torque disturbances and an indirect indication of their amplitudes.

During the tests with greater end play, motor current recordings showed that drag torque was fluctuating cyclically and that the frequencies were ones characteristic of the bearings. It was also discovered that, with the drive upside down, torque noise amplitude was only about 10 percent of the right side up value.

Correlation of torque noise frequency to the bearings was to be expected, but these results caused us to focus our attention on the lower bearing mounts. We knew that the bearing by itself did not cause high torque, and we knew that, when it ran essentially unloaded (drive upside down), overall torque stayed low, at least in the cold chamber.

Test With Two New Lower Bearing Mounts

Because we now suspected the lower bearing mounting hardware, a new, simple outer ring mounting plate (end plate) was made from mild steel, and a spare engineering model stubshaft was located. Both bearing ring fits were made nominally 0.001 in. loose instead of line-to-line to tight, as on the flight hardware, and end play was adjusted to 9 mils. As shown by Curve 6 in Figure 6, these changes were magic! Torque was below 4 oz-in. at -50°C with the DDA right side up. We now had to discover why.

Test With Different Stubshaft Alone

The next experiment was to try the new stubshaft by itself, with the flight end plate. Again torque stayed low, perfectly duplicating results of the previous test with both lower bearing mounts changed. Data points from this test (x's) mingle with the ones of the previous test (o's) on Curve 6.

From this test result, we concluded that the end plate did not enter into the problem, but later we came to a different conclusion.

Lower-Bearing Inner-Ring Fit Test

The engineering model stubshaft which presented such favorable results had an undersize bearing journal that resulted in a 1-mil clearance with the bearing. To find out if this was making such a significant difference, the bore of a spare bearing was ground out to a 1-mil clearance with the flight stubshaft. When this combination was evaluated with the flight end plate, torque was again high and duplicated Curve 4, Figure 5 (7.6 oz-in. at -25°C).

This test showed that the snug inner ring fit of the lower bearing did not cause the problem.

Tests With New End Plate Alone

Going back to both flight bearings, we tried the flight stubshaft with the special steel end plate. We had already shown that the combination of flight end plate and special stubshaft was just as good as the special end plate and special stubshaft, so we might have expected that the new configuration would bring us all the way back to our original high torque curve. This did not occur. The special end plate used with the regular stubshaft somehow significantly reduced the adverse effect of the flight stubshaft (see Curve 7, Figure 6). We then rotated the special end plate 90 degrees and found that this greatly reduced the improvement (8.1 oz-in. at -36°C). Returning it to its original position resulted in repetition of Curve 7 results.

We now saw that the end plate might contribute to or ameliorate the torque problem, depending on its angular location with respect to the main aluminum housing to which it was attached.

Tests With Regular End Plate in Different Positions

With this new knowledge, a series of tests with the flight end plate in different angular positions was conducted. We discovered that flight end plate position did indeed affect low temperature torque, and that results at any position were quite repeatable. Furthermore, the position for the as-built DDA was the worst one - somebody's law at work! In its most favorable position, the drag torque was as shown by Curve 8, Figure 7. Instead of over 20 oz-in. at -50°C , we had only 7.5 oz-in., and the sharp knee in the curve was gone. Compare Curve 8 with baseline Curve 4, which has been repeated in Figure 7, for reference.

Stubshaft Tests

Results by this time led to close scrutiny of the flight stubshaft. The first test was to rotate it 180 degrees with respect to the main aluminum shaft. Results essentially duplicated Curve 8 (7.4 oz-in. at -46°C). We then

made a series of measurements on the flight and engineering model stubshafts to try to discover any significant differences (see Figure 8 for stubshaft details):

- Axial distortion between shaft flange and bearing thrust shoulder as temperature was reduced to -50°C . On the flight part, we found 0.0001 in. and 0.0002 in. change in two locations, while the engineering model stubshaft was worse (0.0004 in.).
- Changes in two bearing journal diameters, 90 degrees apart, between room temperature and -50°C . Both diameters on both parts changed the same amount (-0.0016 and -0.0017 in.).
- Roundness of bearing journals. The flight journal was round within 0.0001 in. while the engineering model part was off as much as 0.0004 in. Since the latter journal was intentionally undersize and a loose fit, any effect of the poor journal roundness would have been suppressed. Excellent roundness of the flight journal indicated that it could not be a problem.
- Concentricity between bearing journal and pilot diameter. Flight part concentricity was within 0.0003 in. while the engineering model part showed 0.0001 in. This difference seemed negligible.
- The flight journal was larger than the engineering model journal, and was also 0.4 mil over the drawing dimension. This diametral difference had already been discounted by test results.
- Parallelism between the shaft flange face and the bearing thrust shoulder. The engineering model stubshaft showed essential parallelism, but the flight part was off 0.0007 in. For the 3.2 in. diameter of the thrust shoulder, this corresponds to an angular deviation of 0.8 arcminute.

The only significant difference that was worse on the flight stubshaft was the seemingly insignificant reduced parallelism between flange and bearing thrust shoulder. With the bearing ring slightly tight on the journal, so that it should only bottom out on the high point of the shoulder, it hardly seemed possible that this could make any functional difference. Nevertheless, we promptly made a mild steel stubshaft, duplicating the flight bearing journal diameter with its tight fit to the flight bearing, but holding parallelism of the two critical surfaces within 0.0001 in. When this part was tried out in the DDA, Curve 9, Figure 7, we had found another piece in the puzzle. The new stubshaft was noticeably better, bringing -50°C torque down to the 6-7 oz-in. range.

With this finding, we had the flight stubshaft thrust face trued up on a jig grinder (measured parallel to the shaft flange within 0.3 arcminute) while removing 0.0005 in. from the journal. The DDA now tested even better than

with the new steel stubshaft, illustrated by Curve 10, Figure 7, after being cleaned up and made ready to repeat some of the formal acceptance tests. At -50°C , torque was 5 oz-in., just meeting the original specification requirement.

Improving parallelism between the bearing thrust shoulder and shaft flange, and slightly opening the inner bearing ring fit, had made a further significant reduction in -50°C torque.

Acceptance Test and Other Results - Complete Success

During acceptance tests, drag torque was measured in vacuum at 22°C and -51°C , where it was 2.6 and 3.4 oz-in. Curve 11 on Figure 7 shows these final results.

The second flight DDA also had high torque when cold. It was corrected exactly the same way, by trueing the stubshaft and finding the best position for the end plate.

HELIOS B was operational for four years until a TWT failure occurred. HELIOS A was still going in December 1984, ten years after launch. We were told that its drive had been turned off for 29 days during 1982 to conserve battery power, because solar cell degradation had occurred. Apparently the DDA whose travails are discussed here ran nearly continuously at 60 RPM for ten years. It may still be running as this is written in December 1986, twelve years from launch.

CONCLUSIONS

The preceding sections have ended with "what" conclusions, when applicable. It remains to decide the "whys." As soon as the problem was corrected, no more funds were available from this fixed price program for further investigation, so the only evidence to work with is summarized here.

The lower bearing inner race seat was not quite perpendicular to the shaft axis, after assembly. (This is presumed from the piece-part measurement.) With this bearing on top, so that it was unloaded, the small deviation made no difference. At room temperature and with a 10-lb load, there was no difference, but at -50°C the difference was significant. Improving the perpendicularity error from 0.8 arcminute to 0.3 arcminute dropped bearing drag at -50°C about 40 percent. Why?

With a steel end plate, which had a slip fit for the lower bearing outer race, and a stubshaft that did not have the bearing shoulder perpendicularity error, the torque problem disappeared. Replacing the new end plate with the flight plate did not affect these favorable results. The problem must have been with the stubshaft alone. Yet, when we then combined the original stubshaft with the new end plate, torque was much better than with the flight plate. Furthermore, rotating the plate to a different position with respect

to its mating housing changed results substantially. Then we discovered that rotating the regular flight end plate to different positions on the housing caused even greater effects on torque. In the most favorable position, torque was greatly reduced. Why?

Starting with the end plate, one must assume thermal distortion caused by anisotropic properties. But then, since the plate rotated at 60 RPM, why would its position relative to the aluminum housing make a difference? Distortion in the housing must also have occurred. Since torque was sensitive to the relative position of both parts, both must have distorted and there was some position where effects were compensating, or largely so. This also indicates that the distortions were not rotationally symmetrical. Since neither the engineering nor qualification models showed the problem, it is also clear that it was not inherent in the design. Both the end plate and housing must have been anisotropic and we were fortunate that the effects were compensating at some position of the two.

The stubshaft is more puzzling. This piece, with short axial dimensions, was fastened to a long aluminum tube with great axial rigidity by twelve screws. The tube should have been dominant, yet there were very significant performance differences between two quite similar parts. Apparently valid thermal distortion measurements on these parts in the free state showed the part that performed better was, if anything, slightly less isotropic. Did the seemingly small perpendicularity problem on the flight part add to some thermal change on the shaft and just carry the assembly over a critical threshold? It appears that this must have been the case.

ORIGINAL PAGE IS
OF POOR QUALITY

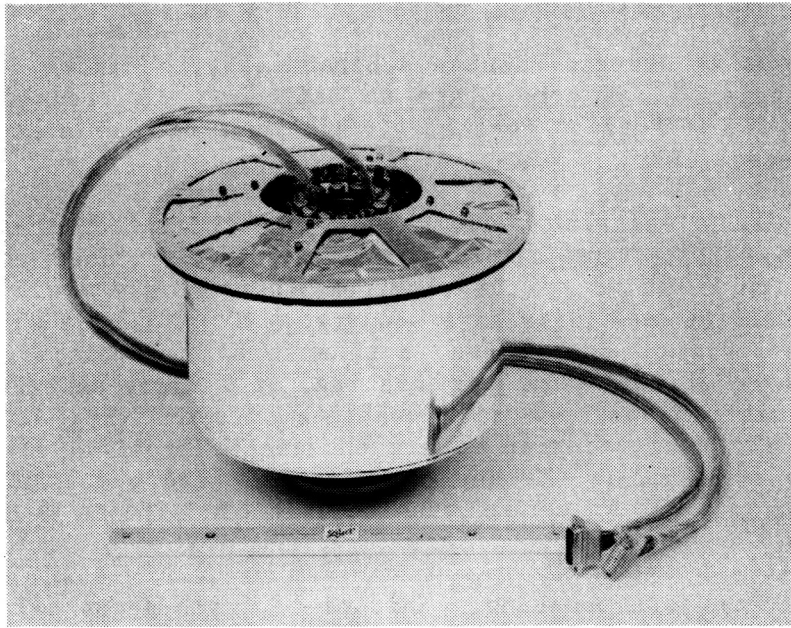

Figure 1 Despin drive assembly

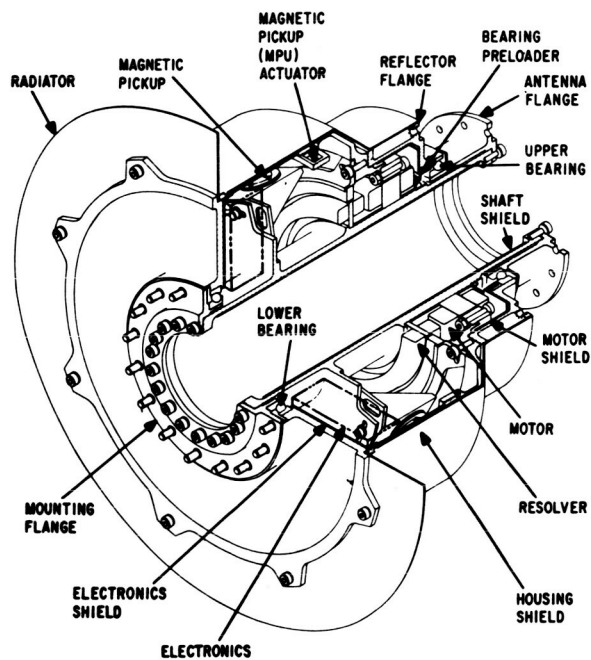
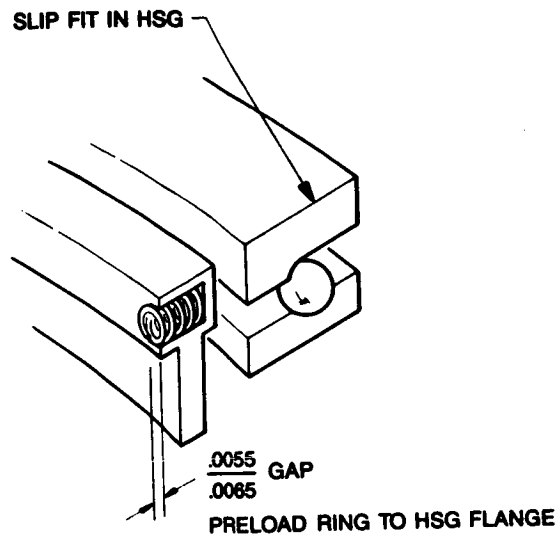

Figure 2 EMS-331 despin drive assembly



DETAIL A

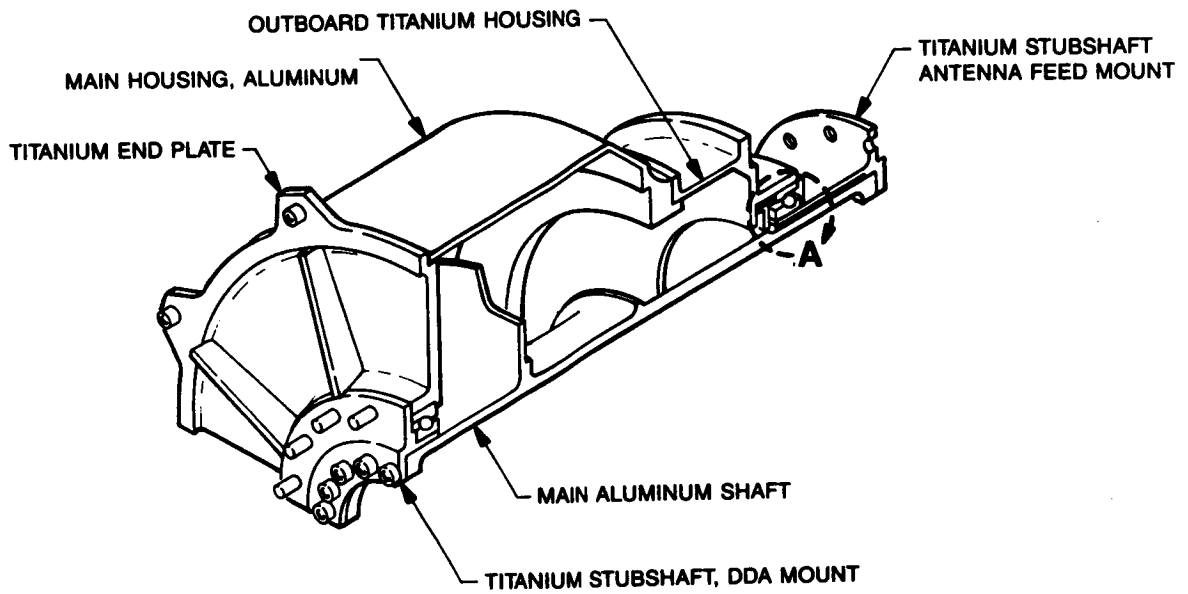

Figure 3 Bearing installations

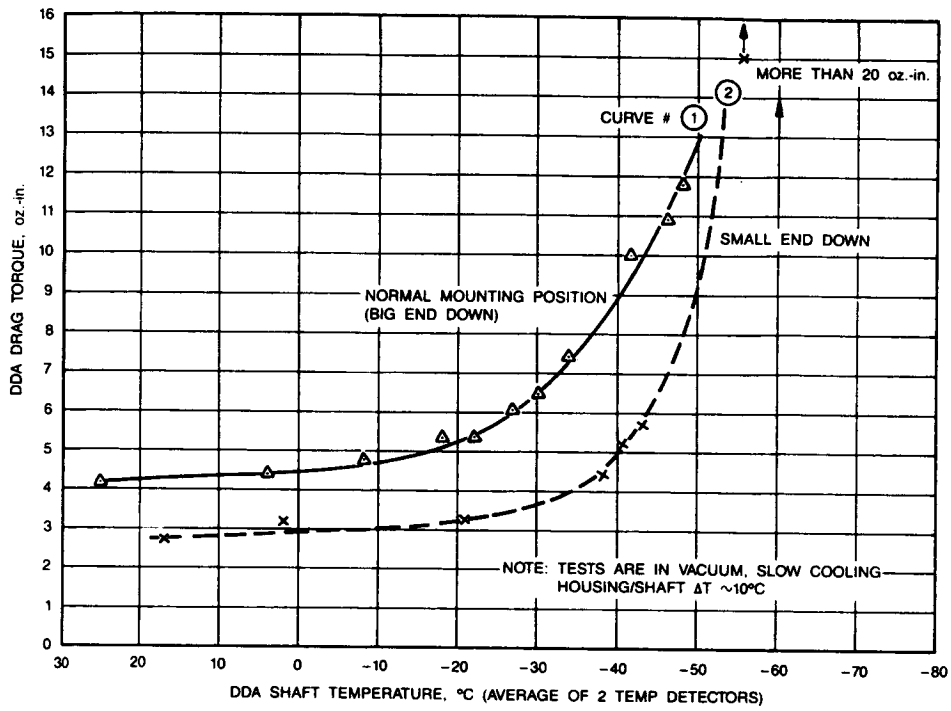

Figure 4 Torque vs. temperature, 1st flight DDA in thermal vacuum chamber

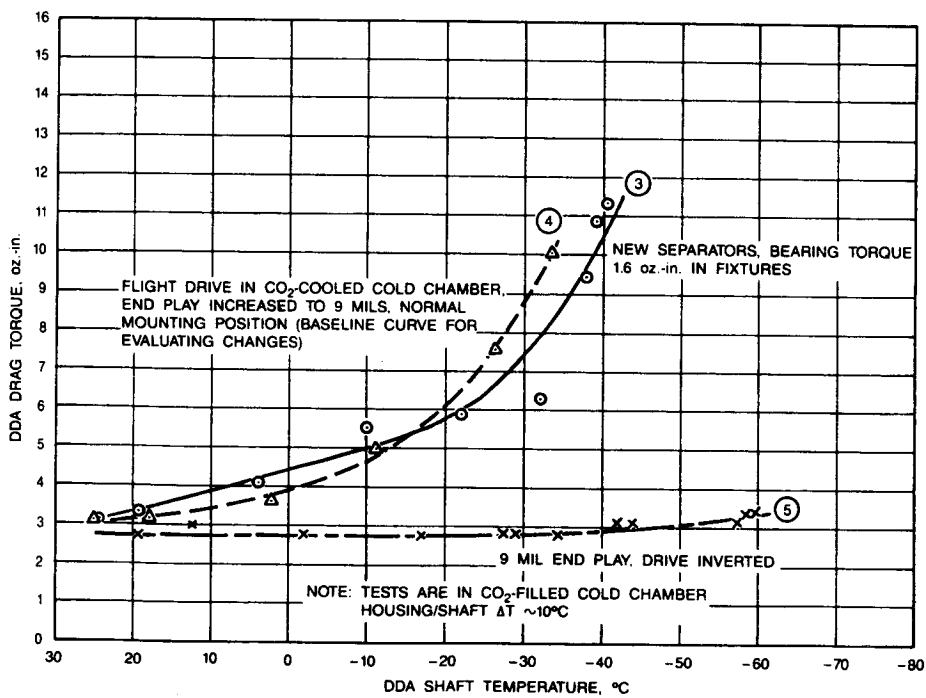

Figure 5 Cold chamber test results with new bearing separators and increased end play

ORIGINAL PAGE IS
OF POOR QUALITY

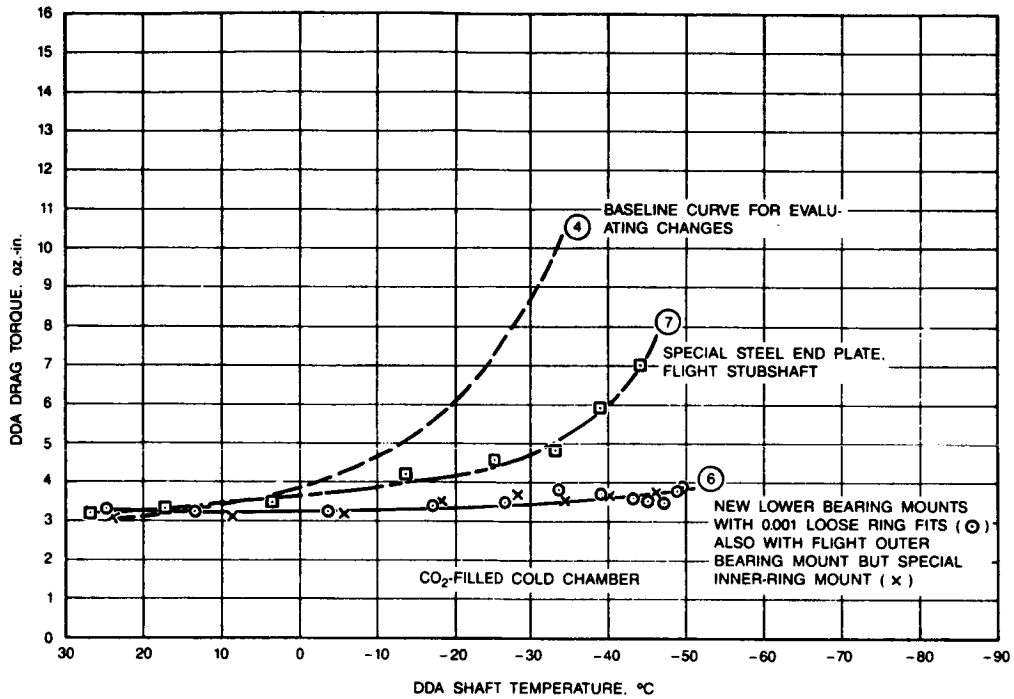

Figure 6 Performance with new lower bearing mounts

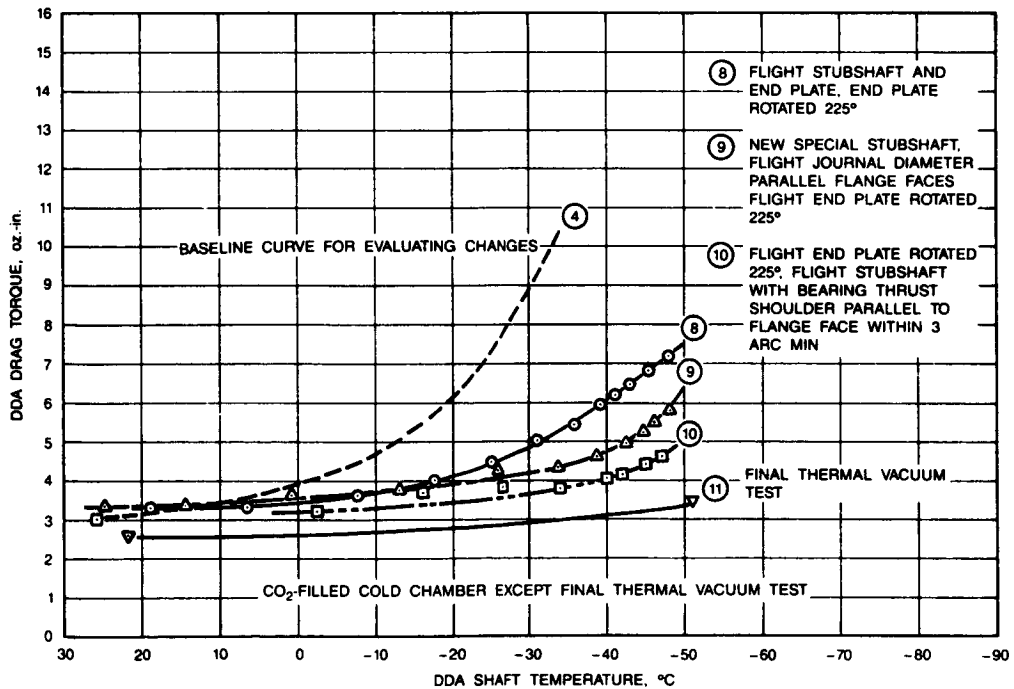

Figure 7 Performance with bearing mount changes that corrected the problem

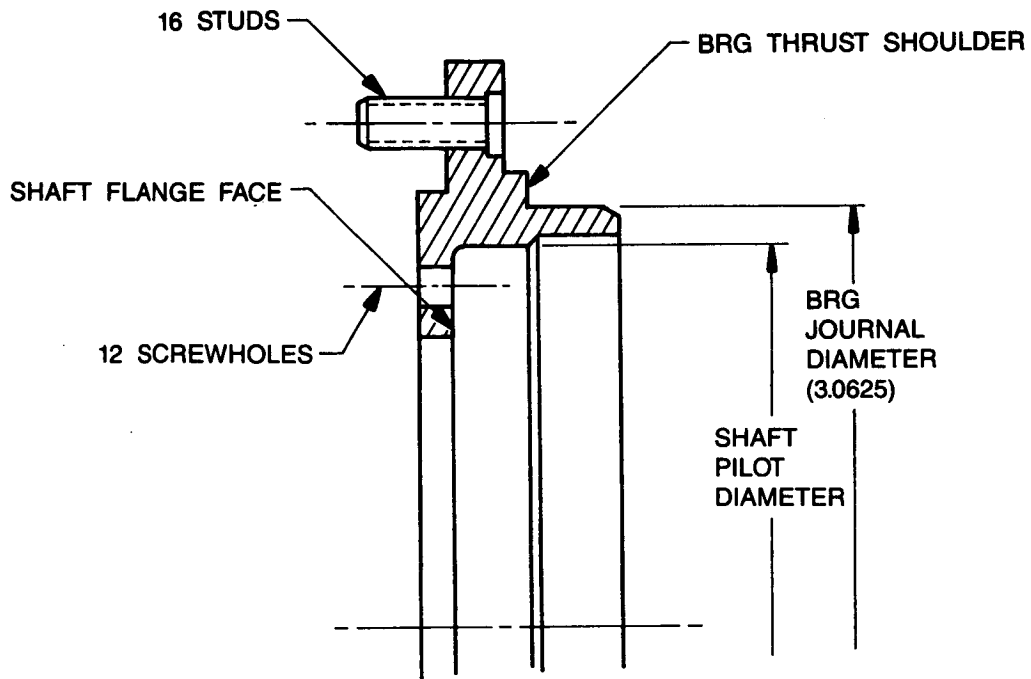

Figure 8 Lower stubshaft configuration