

N87-29882

SPACE STATION ALPHA JOINT BEARING

Michael R. Everman^{*}, P. Alan Jones^{*}, Porter A. Spencer^{**}

ABSTRACT

Perhaps the most critical structural system aboard the Space Station is the Solar Alpha Rotary Joint which helps align the power generation system with the sun (Figure 1). The joint must provide structural support and controlled rotation to the outboard transverse booms as well as power and data transfer across the joint. The Solar Alpha Rotary Joint is composed of two transition sections and an integral, large-diameter bearing. Alpha joint bearing design presents a particularly interesting problem because of its large size and need for high reliability, stiffness, and on-orbit maintainability.

The discrete roller bearing developed is a novel refinement to cam follower technology (Figure 2). It offers thermal compensation and ease of on-orbit maintenance that are not found in conventional rolling element bearings. This paper is a summary of how the bearing design evolved. Driving requirements are reviewed, alternative concepts assessed, and the selected design is described.

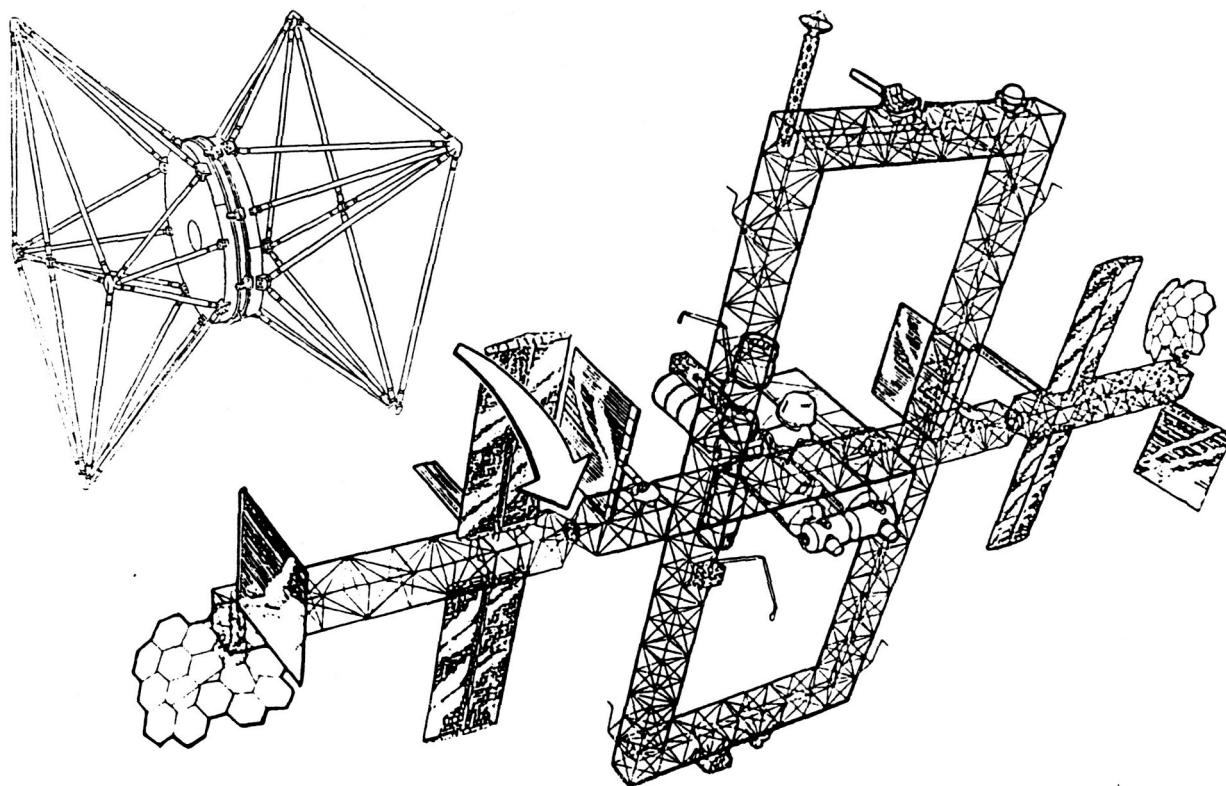

Figure 1: Dual Keel Space Station

^{*}AEC-Able Engineering Co., Goleta, CA

^{**}Lockheed Missiles and Space Co., Sunnyvale, CA

ORIGINAL PAGE IS
OF POOR QUALITY

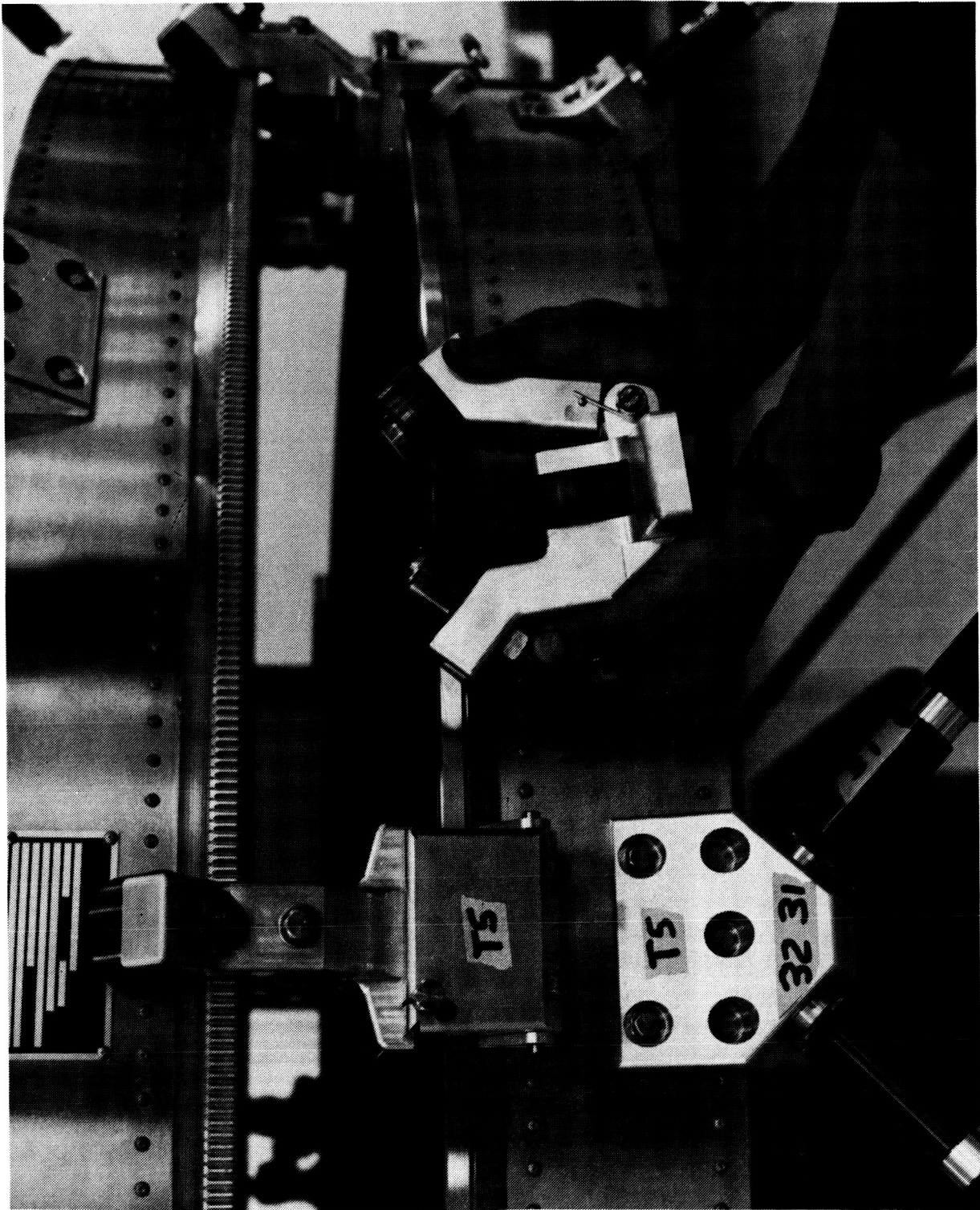

Figure 2: Discrete Roller Bearing

REQUIREMENTS

The alpha joint is designed to meet the performance requirements presented in Table 1.

Table I: Alpha Joint Requirements

Travel	360°	360°
Operational Life	Indefinite	Indefinite
Pointing Accuracy (degree)	±3.0	±3.0
Rotation Rate (deg/min)		
Maximum Slew/ Nominal Tracking	30/3.8	30/3.8
Acceleration (deg/sec ²)	0.005	0.005
Bending Loads		
Maximum	47,451 (N-m)	420,000 (in.-lb)
Nominal	14,122 (N-m)	125,000 (in.-lb)
Shear Loads		
Maximum	2224 (N)	500 (lb)
Nominal	890 (N)	200 (lb)
Torsional Loads		
Maximum	20,336 (N-m)	180,000 (in.-lb)
Nominal	3107 (N-m)	27,500 (in.-lb)
Inertia Loads	5.15 x 10 ⁶ kg-m ²	3.8 x 10 ⁶ (slug-ft ²)
Stiffness		
Bending	1.81 x 10 ⁸ (N-m/rad)	1.6 x 10 ⁹ (in.-lb/rad)
Torsion	4.745 x 10 ⁷ (N-m/rad)	4.2 x 10 ⁸ (in.-lb/rad)
Shear	1.243 x 10 ⁷ N/m	7.1 x 10 ⁴ (lb/in.)

While loads, acceleration rates and inertias have a definite influence, the thermal environment, high stiffness, and need for a highly reliable and maintainable system became the primary design drivers.

Because the bearing is so large (3.05 m) (120 inches) in diameter, tolerances and clearances are critically sensitive to thermal deformation. During operation the bearing is heated by solar irradiation on one side while being exposed to deep space on the opposite side. In addition, a power transfer module located coaxially within the bearing is a source of waste heat that tends to warm the interior of the bearing. With these

factors in mind it was determined that the bearing must be tolerant to both out-of-round and inner race expansion conditions.

The alpha joint structurally supports the large power generation system wing. Stiffness of the joint is important because as stiffness is degraded the fundamental frequency of the wing lowers and introduces dynamic conditions that are more difficult to control.

The Space Station is designed for a twenty year life, extendable indefinitely through maintenance. The alpha joint is critical to mission success because, in the event of failure, power generation capability and mission capability would be severely degraded: payloads would have to be shut down and mission activities would have to be curtailed in an effort to conserve power. Therefore, ease of on-orbit maintenance is desirable.

BEARING TRADE STUDIES

The bearing concepts selected for analysis were four point contact, crossed roller, three row roller, and discrete follower. The four point contact was discarded due to an intolerable wear condition under a bending moment load. To meet the requirement of thermal compatibility the remaining bearing concepts were modified to provide added radial compliance to induced thermal strains (Figure 3). This passive approach to thermal compatibility is less complex and less costly than an active approach. The crossed roller and three row roller designs were discarded because they are difficult to maintain and prohibitively complex to manufacture. A failure of a continuous race bearing requires partial station disassembly, significant loss of power generation and myriad support equipment to replace the entire bearing. Manufacturers of large diameter bearings declined to bid on the thermally compensated designs citing excessive risk. The discrete follower bearing was then selected for detailed design and development.

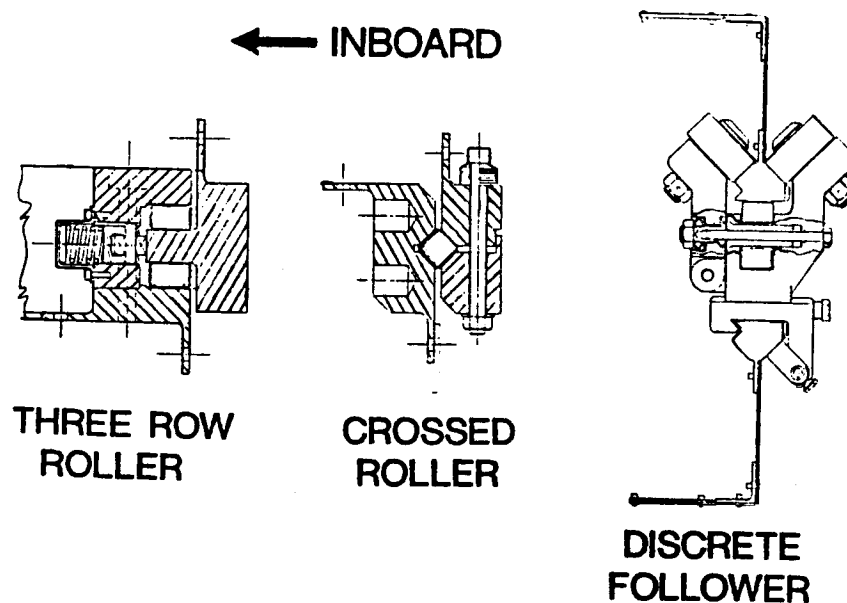

Figure 3: Temperature Compensating Bearing

DISCRETE ROLLER BEARING DESCRIPTION

Discrete Roller Package

The geometry of this system is such that the rotating and non-rotating structures are identical (Figure 4). Reasons for this are: (1) the two structures have matched thermal expansion properties, (2) a redundant ring race is provided, and (3) identical transition structures may be used, saving cost by increasing commonality.

Bearing packages are composed of the three roller bearings, a preload arm, yoke, and dovetail mount. The package spring preload reduces the drive torque variance should there be any variance in the race cross-section. The individual rollers are chosen for low Hertzian stress between the roller outside diameter and the ring race surface. Life expectancy of these bearings is in excess of the system lifespan. Each roller contains a self-alignment feature that provides a degree of freedom such that line contact is maintained at all times with the ring race.

The roller package is installed radially with a dovetail mount. Tightening of the main attachment bolt initiates the full predetermined preload. This bolt cannot change the preload if overtightened. Each roller package is allowed to align itself on the diameter of the rolling race before the dovetail is tightened down. The dovetail mounting is then tightened down to complete the change-out. The mounting block is attached to the triangular ring race on the non-rotating side of the joint. In case of a roller failure, the package can be easily replaced by extravehicular activity (EVA) without sophisticated aligning techniques. Should the rotating race be damaged, then all mounting blocks can be removed sequentially and placed on the formerly-rotating race to utilize the redundant race.

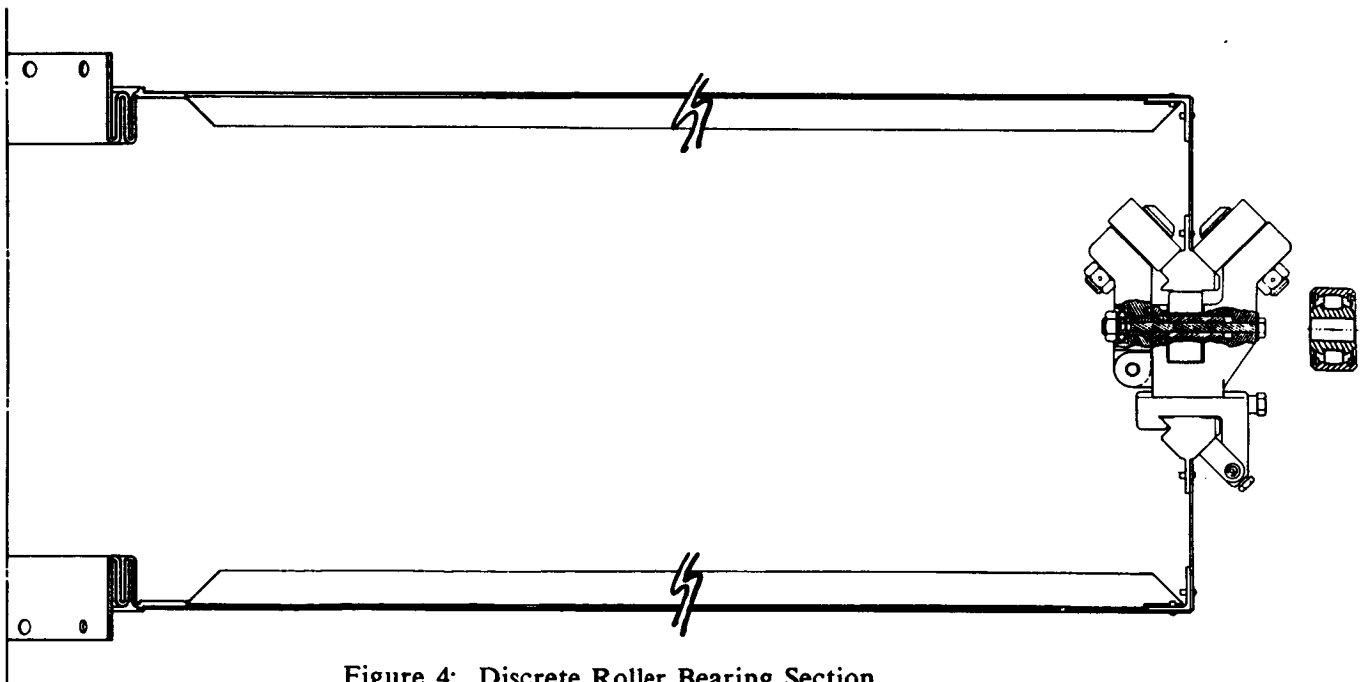

Figure 4: Discrete Roller Bearing Section

Bearing Race and Skirts

The skirts which support the triangular bearing races serve two functions: (1) their height and thickness provide axial stiffness between load inputs and (2) their radial compliance lessens the impact of thermal distortions and manufacturing out-of-roundness.

Shear Panel

Each half of the alpha joint transition structure must have a radial stiffener for two reasons. First, because of the offset between the bearing diameter and the main truss, the transition struts must join the bearing at some angle and therefore transmit load radially as well as axially. Second, since the bearing skirts are designed to be radially compliant (to reduce roller loads in response to thermal gradients and manufacturing tolerances) the transition radial loads must be accommodated for above the skirt. The shear panel is the only area in which radial stiffness is important, i.e., resolving the radial component of bending moment load.

DISCRETE FOLLOWER ANALYTICAL CONSIDERATIONS

Roller Bearing

One of the critical design parameters is the fatigue life at the race to roller interface. Since there are fewer load carrying elements than a similar continuous rolling element bearing, the loads per roller are greater. To determine these loads it was assumed that under a bending moment load the bearing races remained planar and thus produced a linear load distribution. The maximum operational roller axial load of 3389 kg (762 pounds) occurs at zero degrees of transition structure offset.

Now the amount of bearing preload can be defined. The preload spring constant can be deleted from the system stiffness calculation if the preload is larger than the expected operational load. This is possible since, as the preloaded package is loaded, the preload arm does not move and therefore the loads in the outboard rollers are constant. With the application of a tension load the preload on the center roller reduces to maintain equilibrium. A compressive load directly increases the load on the center roller. In this way the axial loads are "accommodated" by a variation of the center roller preload. Due to the geometry of the preload arm, the load at the springs must be 4408 N (991 pounds) to obtain a 1696 N (381 pound) load at the outboard rollers. This results in a 3389 N (762 pound) normal preload on the center roller. To obtain the 4408 N (991 pounds) of spring force, two serial rows of three parallel 1.27 cm (one half inch) inner diameter Belleville washers are used.

With the internal load distribution defined, it is possible to calculate contact stresses by¹:

$$\sigma_c = 0.798 \{ \bar{P} / D_R W_R [(1 - \nu_R^2) / E_R + (1 - \nu_r^2) / E_r] \}^{1/2} \quad (1)$$

where

D_R, W_R	...Roller dimensions
ν_R, ν_r	...Poisson's ratio
E_R, E_r	...Material modulus
P	...Load

The loading, \bar{P} , that the race experiences varies with time. In order to determine the mean and alternating stress levels a time averaged loading must be determined. Resulting loads are:

race loads			
mean	=	89 N	(20 lb)
alternating	=	2157 N	(485 lb)
Roller loads			
mean	=	342 N	(77 lb)
alternating	=	2157 N	(485 lb)

The fatigue life requirements of the race material are determined by the requirement that the alpha joint system rotate for 20 years at 1 revolution every 94 minutes. The resulting required lives are:

L10 RACE	=	1.40×10^6 cycles
L10 ROLLER	=	1.05×10^7 cycles

These values include a safety factor of 1.5.

Expected fatigue lives were determined from the mean and alternating contact stress levels. From those results the race material was selected to be Al 7075-T7351 and the roller was selected to be Ti 6Al-4V. This choice gives a race life margin of 0.51 and a roller margin of 0.50.

Drive Requirements

The alpha joint drive system must impart enough torque to the system to overcome the various frictional losses as well as accelerate the system at the required rate. Table I

1. Roark, R. J., Formulas for Stress and Strain, McGraw-Hill, 4th Edition, 1965, p. 320.

gives the maximum rotational acceleration as 0.005 deg/sec². The required torque can then be expressed as:

$$T_{REQ} = I\alpha + 8(R\mu\sum F_{pre}) + T_{RR} \quad (2)$$

where

- α ...Rotational acceleration.
- I ...Inertial load outboard of alpha joint.
- R ...Bearing radius.
- μ ...Frictional coefficient of roller bearing.
- $\sum F_{pre}$...Summation of trundle preload forces (8184 N/1840 lb)
- T_{RR} ...Torque loss of roll ring power transfer (6.8 N-m/60 in.-lb)

Lowenthal² gives the roller frictional coefficient as 0.003 which when coupled with a 60.0 radius and the inertial load in Table I gives:

$$T_{REQ} = 1065 \text{ N-m (9398 in-lb)}$$

This includes a margin of 1.0 on frictional losses. This torque corresponds to a total drive shear force requirement of 697 N (157 lb) at the bearing race.

Temperature Gradient Capability

The loading of the roller packages due to a thermally-induced strain is dependent on the stiffnesses of the skirt and the race ring. When the races are thermally displaced, three deformations occur (Figure 5). The skirt will experience a bending which creates a distributed shear load at the race. This shear load transmitted through the offset roller packages creates a moment that induces additional radial and angular deflection. Deformation must occur in the ring race as it is strained to match the skirt deflection at the eight roller locations. The coupled radial stiffness for this deformation is given as:

$$K_R = \frac{(\pi DR^4\beta/2EI) + (2/\lambda^3) + (1/\lambda^2)}{\beta R^3/2EI [(4/\lambda^3) + (41/\lambda^2) + (21^2/\lambda)]} \quad (3)$$

where

- D = $Et^3/12(1 - \nu^2)$
- λ = $[3(1 - \nu^2)/R^2t^2]^{1/4}$
- β = $(1/\sin^2\Theta)[(\Theta/2) + (\sin\Theta\cos\Theta/2)] - 1/\Theta$
- E Material modulus
- t Skirt thickness
- ν Material poisson's ratio
- R Bearing diameter
- Θ Half the angular gap between packages
- I Ring race moment of inertia

2. Lowenthal, S. H., and Schuller, F. T., "Feasibility Study of a Discrete Bearing/Roller Drive Rotary Joint for the Space Station", NASA Lewis TM-88800, July 1986.

When evaluated for the baseline design, the radial stiffness is:

$$K_R = 12067 \text{ N/cm (6891 lb/in.)}$$

For a temperature gradient, ΔT , the induced radial strain is:

$$\delta_R = R \cdot \Delta T \cdot \text{CTE} \quad (4)$$

and the amount of tolerable temperature gradient is

$$\Delta T_{\text{max}} = F_{\text{pre}}/K_R \cdot R \cdot \text{CTE} \quad (5)$$

For a preload force of 1696 N (381 pounds), this corresponds to a maximum thermal gradient of 21.6 °C (70.9 °F). However, this value is not the only constraint on the permissible thermal gradient. As the race to race offset becomes greater, structural stability to the axial loads decreases. This factor must be considered when defining a maximum permissible thermal gradient.

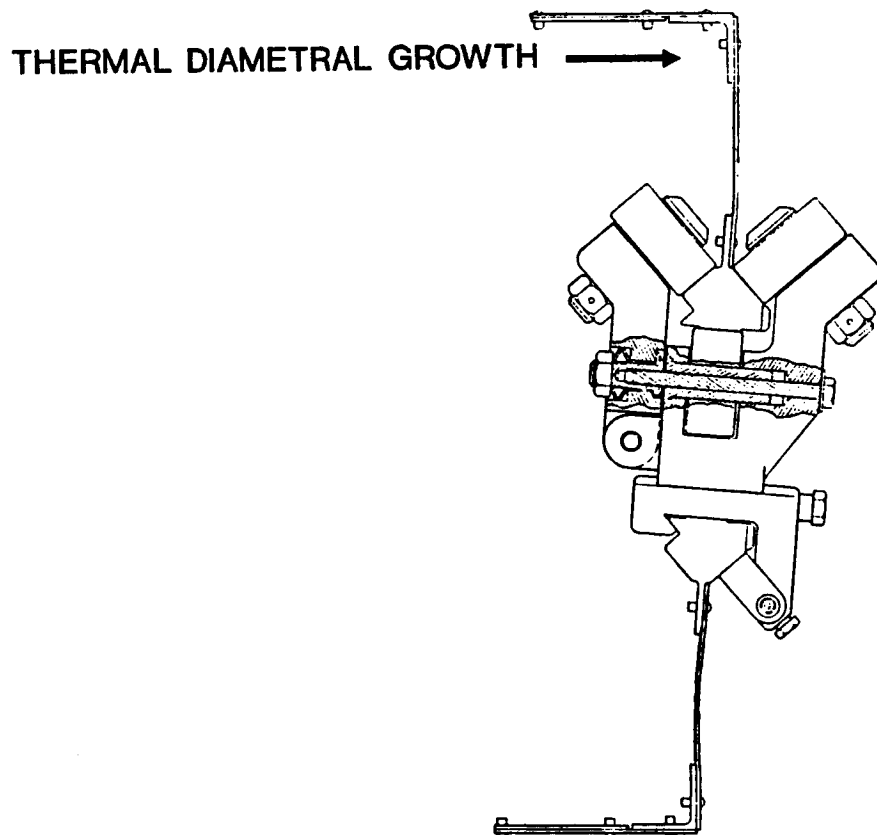

Figure 5: Thermally Strained Bearing

Alpha Joint System Analysis

In order to predict the global response of the alpha joint, finite element techniques were used. The basic method used was to separately model complicated mechanisms such as the race follower package and transition tube and fittings and then integrate their influence coefficients into a global model as general stiffness elements. Also incorporated into the model were standard structural elements. Stiffness predictions are given in Table II for various transition clockings.

Table II: Discrete Follower Analysis

	Transition Offset (Degrees)	Stiffness		Design Margin
		(N-m/rad)	(in.-lb/rad)	
Bending	22.5	1.81×10^8	1.60×10^9	0.0
Bending	0.0	3.60×10^8	3.19×10^9	0.099
Bending	45.0	3.46×10^8	3.06×10^9	0.091
Torsion	45.0	2.36×10^8	2.09×10^9	3.98
Shear	45.0	1.31×10^7 (N/m)	7.5×10^4 (lb/in.)	0.06

STRUCTURAL MODEL TESTING

Due to the uniqueness of the discrete roller bearing design and the importance of its application, it was deemed necessary to conduct a structural test program in the early phases of design development. To this end, a half-scale engineering model was designed, manufactured, and tested at AEC-Able Engineering Co. (Figure 6).

The primary objective of this testing program was to provide "real data" verification of the analytical techniques developed to characterize the discrete bearing design and to determine the presence of any hidden failure modes. In this light, analytical predictions were made for the half-scale model's stiffness. Corresponding structural tests were then performed. Results are presented in Table III and compared to predicted values. Figure 7 gives a sample chart of joint bending versus applied moment for the 22.5° transition offset configuration.

ORIGINAL PAGE IS
OF POOR QUALITY

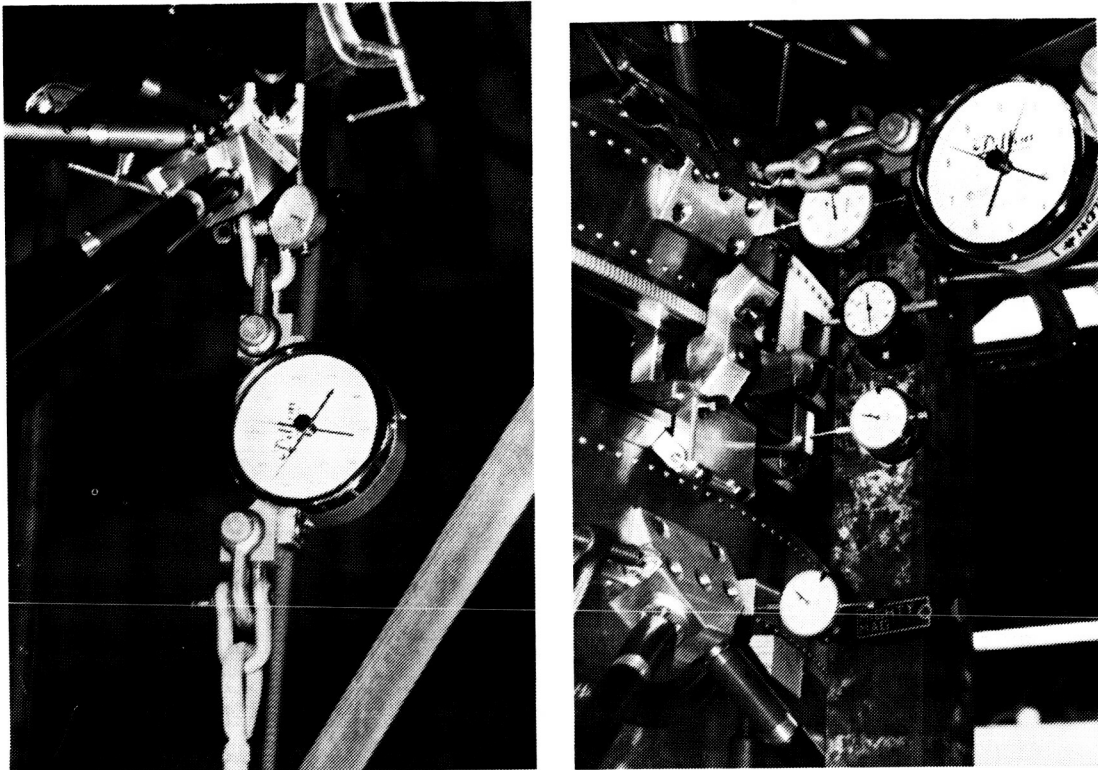

Figure 6: Bending, Shear Test Set-Ups

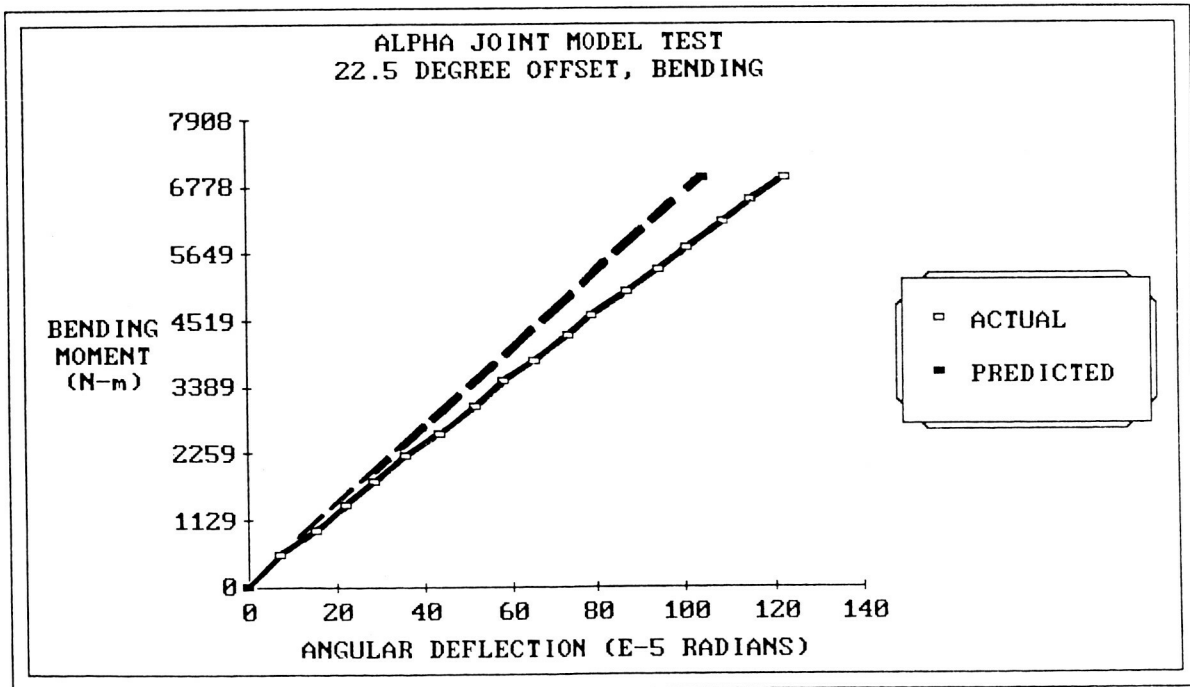

Figure 7: Bending Stiffness Test Results

Table III: Predicted Versus Actual Stiffness

	Bending	Bending	Bending	Torsional	Shear
Offset					
Degrees	22.5	0.0	45	45	45
Maximum Load					
N-m	6892	6892	6892	3451	
N					1334
in.-lb	61,000	61,000	61,000	30,547	
lb					300
Predicted Stiffness					
N-m/rad	6.47×10^6	7.3×10^6	7.3×10^6	1.05×10^7	
N-m					4.78×10^6
Actual Stiffness					
8 Packages					
N-m/rad	6.59×10^6	6.43×10^6	6.17×10^7	9.5×10^6	
N-m					4.32×10^6
7 Packages					
N-m/rad	5.10×10^6	6.05×10^6	5.84×10^6	-----	
N-m					3.82×10^6

The resulting correlation between predicted and observed performance instilled high confidence in the analytical techniques. Also observed was only moderate variation in joint stiffness with transition offset. This is helpful for control system design in which an isotropic alpha joint assumption is made. The system's reliability is verified by the high stiffnesses even when the most severely loaded bearing package is removed.

To verify the thermal compatibility of the bearing design, the current through a gear drive motor was monitored as the thermal load was varied. Both top-to-bottom and side-to-side temperature gradients were imposed. Minimal current variation was observed for either condition and a sample of the test data is shown in Figure 8 for the top-to-bottom thermal loading.

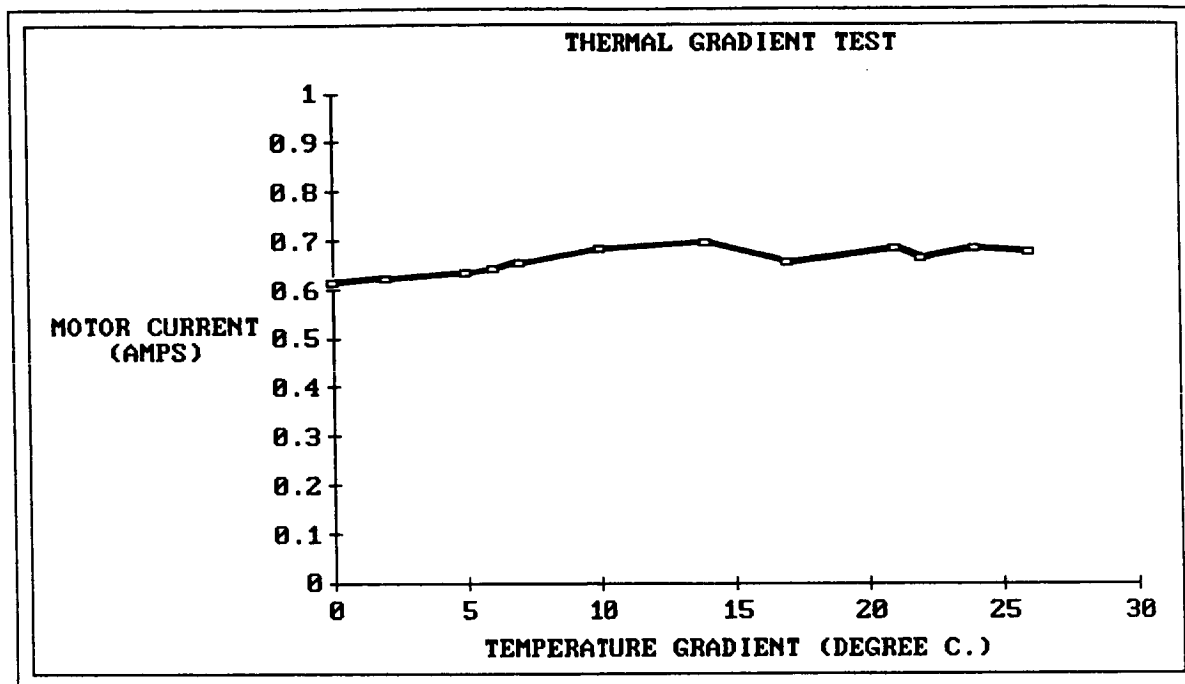

Figure 8: Thermal Gradient Test Results

In order to test the characteristics of the race-roller interface a straight rail tester was designed and built (Figure 9). The frictional load required to drive the race section through the roller packages was measured with a load cell as preload and temperatures were varied. Figure 10 depicts the variation of the drive friction with temperature. The room temperature value of the frictional coefficient (0.0029) verified that used in Equation 2 (0.003).

Lessons Learned

After prolonged running of the 162.5 cm (64 in.) diameter engineering model, minute aluminum deposits could be found on the inboard portions of the rollers. Tapering the rollers will eliminate this condition which is twice as extreme on the model than it would be at full scale. Further improvement can be made by installing finger guards around the rollers for safety. Further work shall include astronaut assembly simulation to provide inputs to maximize serviceability.

ORIGINAL PAGE IS
OF POOR QUALITY

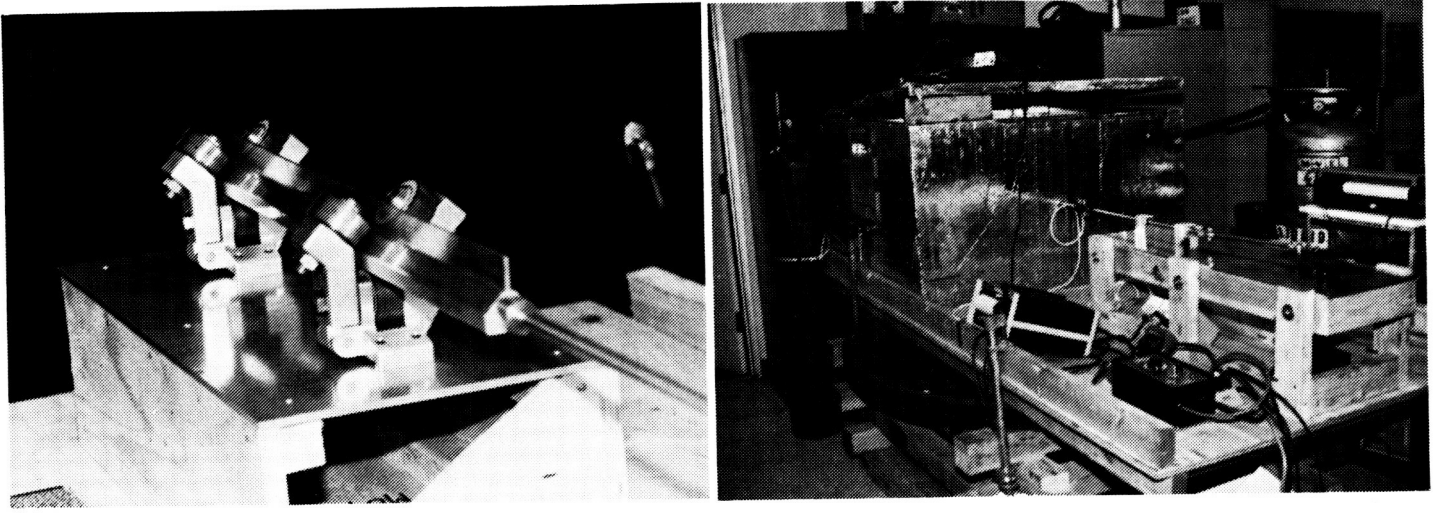

Figure 9: Straight Rail Test Set-Up

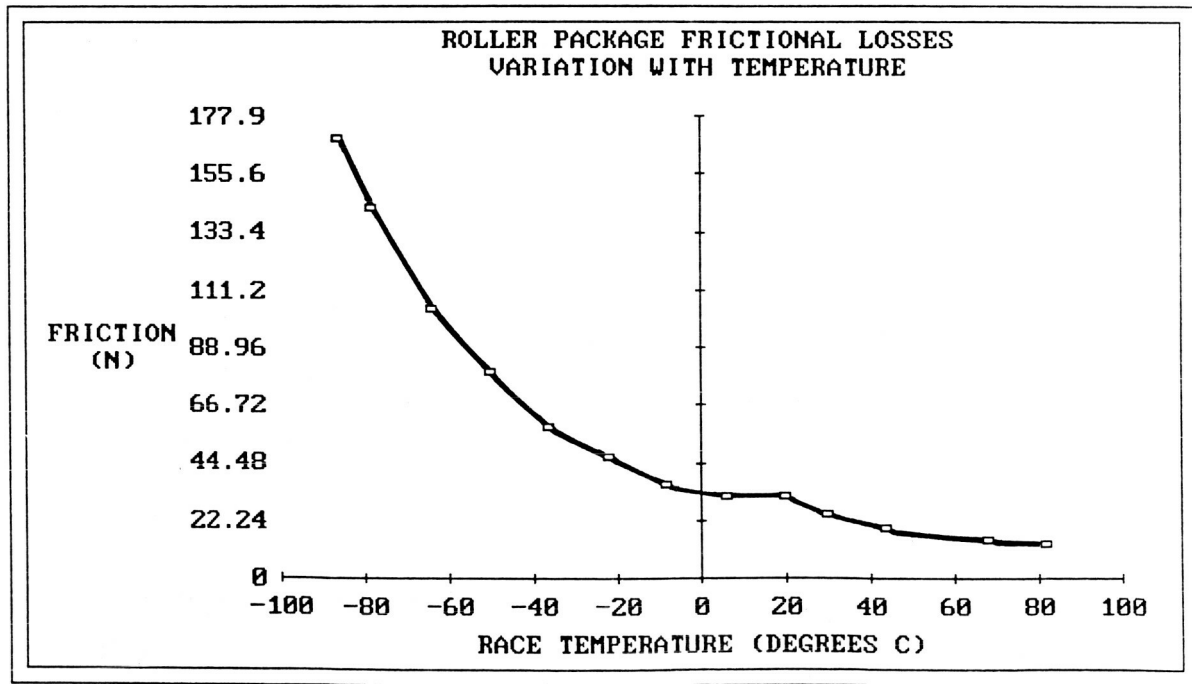
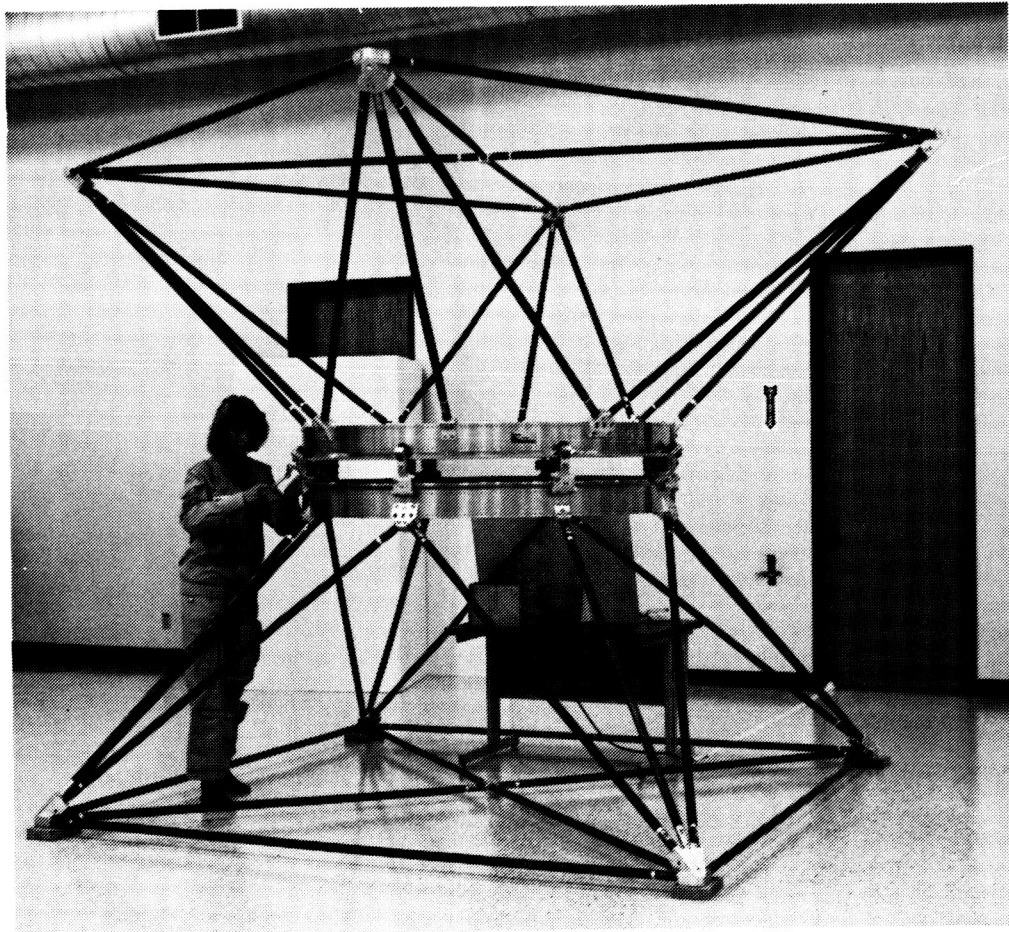

Figure 10: Roller Package Frictional Loss

SUMMARY

A highly reliable and quality performing Alpha Joint is vital to successful Space Station operation. After conducting detailed trades, analyses, concept designs, and after building and testing hardware, the discrete follower bearing concept is clearly best suited to meet the Space Station requirements. The requirements found to be driving the design are reliability, thermal considerations, stiffness and load-carrying capability. Testing of the half-scale engineering model shows a good correlation between analytical predictions and test data. Key features and advantages of this bearing over conventional large-diameter bearings are the ability to accommodate thermal deformations and thermally-induced loads, ease of on-orbit maintenance, and reasonable cost while providing adequate structural strength and stiffness.



Engineering Model