

N87-29922

COST REDUCTIONS IN NICKEL-HYDROGEN BATTERY

Richard L. Beauchamp and Jack F. Sindorf
Johnson Controls, Inc.
Milwaukee, Wisconsin 53201

For the past several years, Johnson Controls, Inc. has been working with COMSAT Laboratories and Sandia National Laboratories on the development of the nickel hydrogen battery for terrestrial applications. We feel that some of the results are sufficiently interesting that consideration of them for aerospace applications is warranted.

The major emphasis of the program was on reduction of the manufacturing cost of the aerospace cell. The intent of the developmental effort was to re-design and re-develop the battery for terrestrial applications where first-cost and life-cycle were important considerations but with only minimal changes in the performance characteristics.

The approach was to adapt JCI's experience in the high-volume production of lead acid automotive batteries to the manufacture of the nickel hydrogen battery. The battery would consist of a number of individual, prismatic cells in a common pressure vessel. The prismatic cells prepared in this developmental effort consisted of a multiple of cell-modules in a back-to-back configuration and were housed in monolithic polypropylene cases. JCI battery manufacturing experience was drawn on to make the batteries and experimental cells.

A significant reduction in cost was achieved through several technical developments, compound changes, and process improvements. Two technical developments led to the majority of the reduction. The first was the development of an energy-efficient 70-mil thick positive electrode. The second was a negative electrode utilizing a platinum-on-carbon catalyst. The thicker positive electrodes permitted a one-third reduction in the number of cell components usually used. A second benefit of the thicker positives was a 45% increase in the cell's ampere-hour capacity. The cost of the platinum-on-carbon catalyst is only 10% of the platinum-black used with aerospace cells. No significant degradation in the performance of the batteries resulted from the use of this catalyst although it was necessary to develop an incoming electrochemical inspection procedure to qualify the catalyst.

As an integral part of the program, the details of the manufacturing costs were carefully studied. One purpose was to highlight those raw material and assembly costs which were most responsible for the high cost of the battery and to provide guidance as to the areas where further development effort would, as above, have the greatest impact. Another purpose of the cost-study was to determine if the ambitious programmatic cost goal of \$375 per kilowatt-hour could be met. The study showed that even at the low production rate of a pilot plant (approximately one Megawatt-hour of batteries per year), the selling price of the re-developed nickel hydrogen battery would be only \$1,451 per kilowatt-hour. The study also pointed out several areas for further research and

development which if successful, when coupled with a higher but reasonable production rate, would make the goal achievable.

INTRODUCTION

The use of nickel hydrogen cells and batteries for storage of photovoltaic energy in aerospace applications was pioneered by COMSAT Laboratories (ref. 1). It is recognized that this battery system has many attributes that make it very useful for similar terrestrial applications. It's clean, with an absence of noxious fumes; it requires practically no maintenance; it has excellent energy efficiency; it has a long calendar life and a long cycle life; and it's highly reliable. Furthermore, the state-of-charge is readily determined as it is directly proportional to the pressure. Unfortunately, the batteries used in aerospace applications have one characteristic that make them unsuitable for terrestrial applications: a very high first cost (ref. 2).

Johnson Controls has been working with COMSAT Laboratories on a program for the Department of Energy under the sponsorship of Sandia National Laboratories for the "Design and Development of 100 AH Hydrogen/Nickel Oxide Batteries". The objective was the development of a nickel hydrogen battery which would be cost competitive with other technologies, including lead acid, for use in terrestrial applications such as the storage of electric power from autonomous photovoltaic installations. The program involves design, development, assembly and testing of cells and batteries, and the preparation of a comprehensive COST-STUDY.

The configuration of the cells and batteries developed for terrestrial applications in this program was a departure from that used in aerospace. The terrestrial cells are prismatic, and the batteries contain a multiple of these cells in a common pressure vessel (see figure 1). High volume manufacturing practices, several of which are identical to those used in the assembly of automotive lead acid batteries, were used to produce the nickel hydrogen cells and batteries. The Battery Division's engineering pilot shop, located near JCI's corporate headquarters in Milwaukee, is equipped with a line of automatic equipment for the assembly of experimental lead acid batteries. This equipment was used in the assembly of nickel hydrogen batteries for processes such as completing the inter-cell connections by resistance welding and for heat-sealing the covers on the battery cases. A flow chart of the processes employed to produce a terrestrial nickel hydrogen battery is shown in figure 2. The similarity between the assembly processes of this battery and lead acid batteries can be seen, and one of the effects of this similarity is a lowering of costs (ref. 3).

The modular building block of JCI's prismatic cell is the cell-module, displayed in figure 3. A cell-module consists of two electrode pairs and separators, bound together by the diffusion screens. Figure 4 shows the arrangement of the components. The positive electrodes are located in the center of the cell-module and are back-to-back. Cell stacking consists of merely bringing the appropriate number of cell-modules together so as to completely fill the cell case. The ease of stacking cells in this manner contributed to the cost reduction achieved. Cells containing from seven through eleven cell-modules have been tested. The theoretical capacities for these cells ranged from 100 AH to 190 AH in cell cases either 3.8 or 5.1 cms thick.

The cell cases are portions of lead acid battery cases and are shown in figure 5.

Testing of experimental cells in boiler plate pressure vessels was done using automatic cell cyclers and a computerized data acquisition system.

Several batteries were assembled and tested during this project. They consisted of either a multiple of individual cells, or a 6-cell monoblock, in common pressure vessels. The cost of the very first battery, assembled by hand in the lab for this project, was determined to be \$5900/kWh. It was also determined from this costing exercise which areas warranted additional research and development to further reduce the cost. The \$5900/kWh cost, although too high for terrestrial applications, was much less than the cost for an aerospace battery. It is realized that this lower cost was due in part to the overall requirements for preparing a terrestrial battery being less stringent than for preparing an aerospace system. A major factor in bringing the cost down to \$5900/kwh was the use of a 10% platinum-on-carbon catalyst in the negative electrode (in place of the pure platinum black used in aerospace cells). Still, the study indicated that the catalyst remained a relatively high-cost item.

Areas, other than the catalyst, seen as significant contributors to the \$5900/kWh price were the:

- a) positive electrode
- b) negative substrate
- c) diffusion screen
- d) battery container/hardware.
- e) KOH usage.

Reducing the costs of the items other than the positive electrodes was fairly straightforward. But a substantial developmental effort was required to effect a cost reduction in the area of the positive. This effort resulted in a 70-mil thick electrode. Going from 32-mil thick electrodes to 70-mil thick electrodes allowed the use of one-third fewer electrodes, separators, and screens. In addition, a 45% increase in AH capacity is now available from the same size cell stack. The "fewer-components" and "capacity-increase" were a two-fold cost-reduction effect by the change of a single component.

POSITIVE ELECTRODE DEVELOPMENT

The quality of the slurry type nickel plaque had been optimized during the developmental effort on the Zn/NiO battery at JCI to the point where it was difficult to distinguish between the JCI slurry plaque and dry powder plaque, including by microscopic examinations. This effort was concentrated on 32-mil thick plaque material. Table 1 reveals minimal differences in physical characteristics between 32-mil slurry and dry-powder plaque. As was mentioned above, the battery costing exercise indicated the need for a thicker electrode; 70-mils was selected as the thickness to develop in order to optimally fill out the cell case.

The problems of sagging slurry, inherent in the thicker applications required for the 70-mil nickel plaque, were overcome through innovative process control. Plaque material, with very a uniform distribution of nickel throughout the thickness, was developed. The good physical characteristics of the 32-mil plaque material were retained; observe also in table 1 that there is very little difference in the physical characteristics between the 70-mil and the 32-mil slurry plaque.

Electrochemical impregnation of the 32-mil plaque had been developed during the Zn/NiO effort. But the impregnation of the 70-mil plaque material required additional developmental effort. The initial thick electrodes did not meet performance expectations, neither in flooded cell tests, nor in actual nickel hydrogen cells. Backscattered electron (BSE) image analysis showed the active material to be concentrated midway between the plane of the grid wires and the electrode surface (ref. 4). Being concentrated, the active material could not be properly utilized, and lower cell voltage and lower AH capacity resulted. An intensive study was undertaken to evaluate the impregnation process. The goals of the developmental effort were to move the zone of precipitation of the nickel hydroxide uniformly throughout the plaque thickness during impregnation, and to shorten the time of impregnation in order to minimize corrosion of the nickel sinter in the hot nickel nitrate solution. The current-time relationships were adjusted to accomplish these objectives. The effort resulted in a much improved distribution of active material with a correspondingly improved utilization. The AH capacity of cells with the new 70-mil electrodes increased by 33%. A comparison of the discharge performances of cells with 32-mil and 70-mil thick electrodes is shown in figure 6. It should be noted that the same size cell stacks were used for both tests.

NEGATIVE ELECTRODE DEVELOPMENT

The goal of this developmental effort was to use the least quantity of platinum while still retaining acceptable levels of cell performance.

A commercially available catalyst (10% platinum-on carbon) was evaluated in polarization tests and in actual H₂/NiO test cells as an alternative to pure platinum black. This catalyst (about 1/10th the cost of the fuel cell grade platinum) was incorporated in a multi-layer composite electrode developed by COMSAT Laboratories. The electrode was made by first roll-compacting Teflon together with the electro-catalyst powder to form one of the layers. This layer was then laminated to one side of a current collecting grid member, with a porous Teflon layer laminated to the other side. Pressing, sintering, and cutting to size completed the fabrication process. Two full-size cells were tested to compare the in-cell performances of the 10% Pt/carbon with the pure Pt catalyst. The discharge capacities of both cells to 1.0 volt were about 103 AH with the mid-discharge voltages of both about 1.25 volts. The discharge capacities are displayed in figure 7. This test demonstrated that, at the discharge rates normally used in terrestrial photovoltaic applications, there is no discernible difference in the performances of electrodes with the 10% Pt/carbon (at .45 mg Pt/cm²) and the pure Pt (at 8 mg Pt/cm²) catalysts. Additional tests were conducted to determine the acceptability of further reducing the platinum loading. The performances of catalysts prepared with 5% and 2% platinum-on-carbon were compared to the 10% Pt/carbon catalyst. The overvoltage of an electrode with 5% Pt/carbon catalyst (at .24 mg Pt/cm²) is very close to that of an electrode with the 10% catalyst at a current density normally used in photovoltaic applications, whereas the overvoltage of the electrode with the 2% catalyst (at .16 mg Pt/cm²) is about 100 mv higher (see figure 8). The processing expense of the 5% and 2% catalysts is a larger component of the total cost and thus there is not a proportionate cost reduction from the 10% catalyst (ref. 5).

Studies were therefore conducted on reducing the quantity of 10% Pt/carbon catalyst used per electrode. The cost reduction this way would be directly

related to the platinum removed. Electrodes were prepared with 0.8, 0.6, 0.4, 0.2, and 0.1 mg Pt/cm² by using appropriate quantities of the 10% Pt/carbon catalyst. In these tests, the average polarization resistances were determined for electrodes before and after sintering. It can be concluded from the data in figure 9, that electrodes containing even less than 0.2 mg Pt/cm² (sintered) give acceptable performance. Life-cycle tests are currently underway to determine whether stable performance can also be obtained using these very low loadings of platinum.

COST STUDY

Studies were performed to determine the cost of manufacturing a 15 kWh H₂/NiO battery in order to : 1) provide bench marks from which more detailed and more realistic cost estimates could be determined, 2) identify the best areas for further cost reduction efforts, and 3) determine if the ultimate cost goal of under \$500 per kilowatt-hour was obtainable. A 15kWh battery was selected because a battery of this size was being considered as a deliverable to Sandia. An initial study was made in 1984/1985 with a refined cost study prepared in 1986.

Some of the features to be incorporated in the battery and which were included in the refined cost study were:

- a) 70-mil positive electrodes
- b) Improved formation process for positive electrodes
- c) 10% platinum-on-carbon catalyst
- d) Electroformed negative grids
- e) Elimination of the porous Teflon film on the negative electrodes
- f) Polypropylene fabric diffusion screens
- g) Low cost intercell connectors and battery terminals.

The impact of both the 70-mil positive electrodes and the 10% Pt/carbon catalyst have been discussed. But just to give an idea of the impact of some of the others:

- a) using an electroformed negative grid instead of a special expanded metal grid reduced the cost by \$405/kWh.
- b) \$43/kWh was saved by using a polypropylene diffusion screen instead of woven screen.
- c) eliminating the porous Teflon film saved about \$92/kWh.

The labor aspect of the cost was considered. Streamlined processes were devised to reduce the labor content to levels normally found in the assembly of lead acid batteries.

Three production levels were studied because production levels have a major impact on the final battery cost. The levels selected coincided with bottleneck manufacturing processes. The nickel plaque sintering furnace, operated one shift per day, would limit production to 72 15kWh batteries per year. If the sintering operation were up-graded, the limiting operation would then be the preparation of the negative electrodes, and 270 battery systems could be produced per year. Investing capital to speed up the preparation of negative electrodes would shift the limiting operation to making the inter-cell connection, and 1024 battery systems could be produced per year. The battery costs at the various production levels are shown in figure 10. The 1984 costs are based on the configuration of the cells and batteries as of July 1984. The

1986 costs reflect continued R&D effort through the first third of 1986 resulting in a price below the \$1000/kWh level.

Because the battery we have been developing will be competing with other terrestrial battery systems, the results of the cost study have been used to generate a cost comparison. From the cost comparisons made in table 2, it is clear that the nickel hydrogen battery is economically competitive with these other systems on a cents/kwh-cycle basis.

ADDITIONAL EFFORTS

Efforts are continuing to develop the nickel hydrogen battery into a marketable product. Under sponsorship of Sandia National Laboratories, a 7 kWh battery is to be assembled and delivered to Sandia for testing in a photovoltaic application. There are corporate plans to assemble similarly sized and larger batteries for testing in the Load Management Facility at Johnson Controls. Cost reduction efforts will continue. Additional cost reductions are anticipated through the use of 90-mil (and thicker) positive electrodes, currently under development. Catalysts, less expensive than platinum-on-carbon, are being evaluated and may prove acceptable. The development of a "production" pressure vessel is underway.

SUMMARY AND CONCLUSIONS

Significant progress has been made toward the development of a commercially marketable nickel hydrogen battery. The costs projected for this battery are remarkably low when one considers where we are on the learning curve for commercialization of this system. Further developmental efforts on this project are warranted as the nickel hydrogen battery is already cost competitive with other battery systems.

REFERENCES

- (1) National Materials Advisory Board, Assessment of Research Needs for Advanced Battery Systems, Report of the Committee on Battery Materials Technology, National Academy Press (Washington, 1982)
- (2) L. Burant & W. Gentry, "An Interim Cost Study of a Terrestrial Hydrogen/Nickel Oxide Battery", Presented at the 18th IEEE Photovoltaic Specialists Conference, Las Vegas, Nevada, 1985.
- (3) J. Sindorf, L. Burant, & J. Dunlop, "Design and Cost Study of a 15kWh Hydrogen/Nickel Oxide Battery for Photovoltaic Applications", Presented at the 20th IECEC, Miami, Florida, 1985.
- (4) J. Dunlop, W. Gentry, et. al., Design and Development of a Sealed 100-AH Hydrogen/Nickel Oxide Battery, Final Report, SAND85-7219, Sandia National Laboratories (1985).
- (5) H. Vaidyanathan & J. Dunlop, "Performance of Carbon-Based Negative Electrodes in the Nickel-Hydrogen Battery", Presented at the 14th International Power Sources Symposium, 1984, Brighton, England.

Ni PLAQUE PHYSICAL CHARACTERISTICS				
	32 MIL		70 MIL	
	JCI SLURRY	DRY POWDER	JCI SLURRY	DRY POWDER
POROSITY %	83.8	83.6	81.9	83.8
AVE PORE DIA μ	8.26	9.00	9.08	8.82
SURFACE AREA μ	.248	.220	.212	.257

TABLE 1

TABLE 2

THIRTY YEAR, 15-kWh PHOTOVOLTAIC BATTERY SYSTEMS AVAILABLE BETWEEN 1986 AND 1991 (*)

	Hydrogen/Nickel Oxide	Lead/Acid		Zinc/Bromine	Sodium/Sulfur
		Flooded	Sealed		
Initial Cost (\$/kWh)	375 to 930	80 to 120	99 to 160	40 to 120	400 to 1,200
Cycle Life (80% DOD)	15,000 to 5,200	1,600 to 800	1,200 to 600	1,800 to 400	2,000 to 900
Units Required (for 10,000 cycles)	1 to 2	7 to 13	9 to 17	6 to 25	5 to 12
PRESENT VALUE (cents/kWh-cycle)	3.8 to 14.5	3.4 to 9.3	5.3 to 16.2	4.7 to 17.8	13.2 to 84.6
Estimated Maintenance Cost (cents/kWh-cycle)	0.1 to 2	6 to 46	0.5 to 17	7 to 54	0.5 to 20
PRESENT VALUE (cents/kWh-cycle)	0.1 to 1.2	3.5 to 26.4	0.3 to 9.8	4.0 to 31.1	0.3 to 11.5
TOTAL LIFE CYCLE COST (cents/kWh-cycle)	3.9 to 15.7	6.9 to 35.7	5.6 to 26.0	8.7 to 48.0	13.5 to 96.1

(*) Costs are in constant, 1986, dollars. Range is from "optimistic" to "reasonable". Present values are calculated using a 4% real discount rate based on 12.5% current discount and 8.5% inflation rates; see DOE/CE-0072: NATIONAL PHOTOVOLTAICS PROGRAM. FIVE YEAR RESEARCH PLAN. 1984-1988.

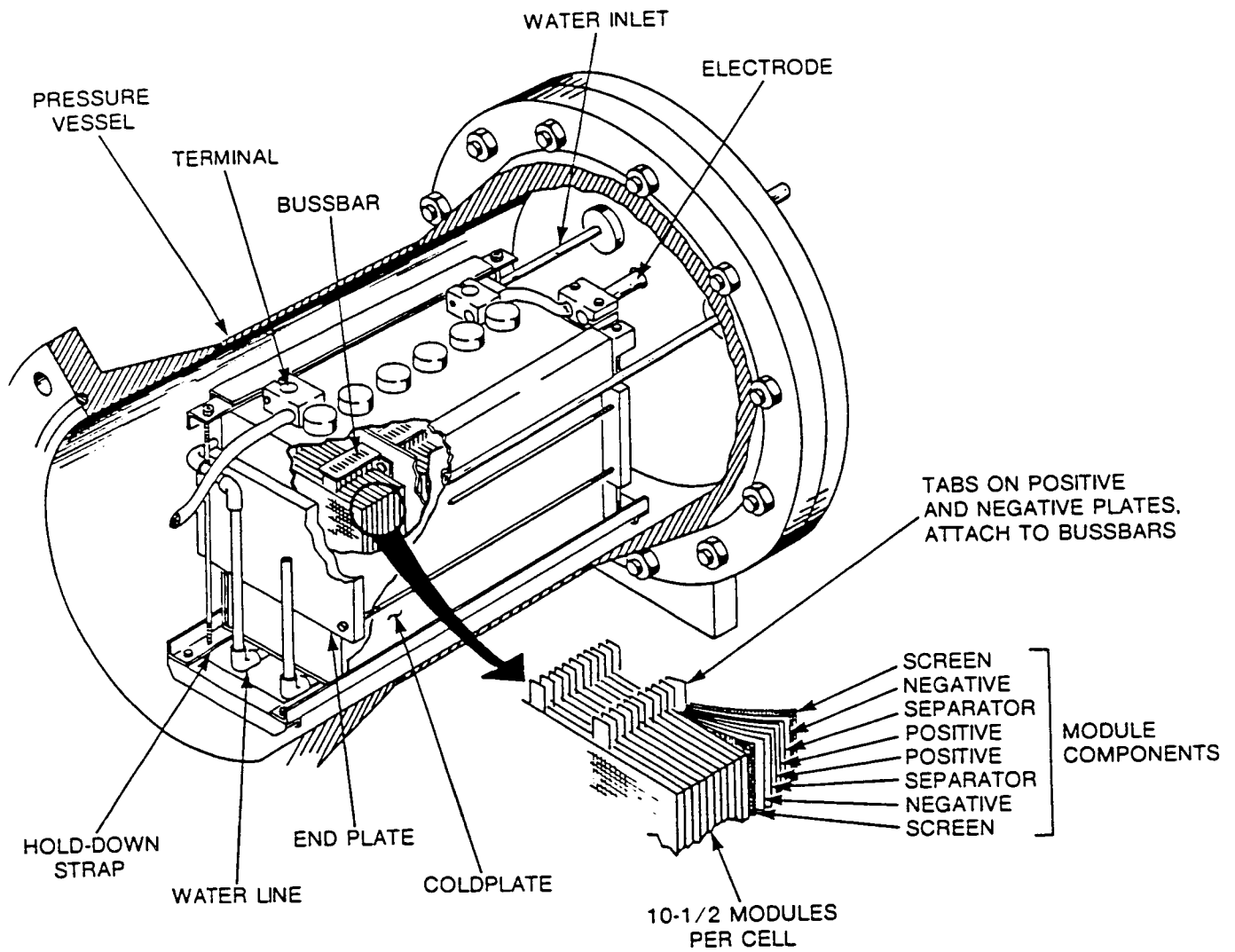

Figure 1 Cross sectional view of a 6-cell hydrogen/nickel oxide battery delivered to Sandia National Labs.

ORIGINAL PAGE IS
OF POOR QUALITY

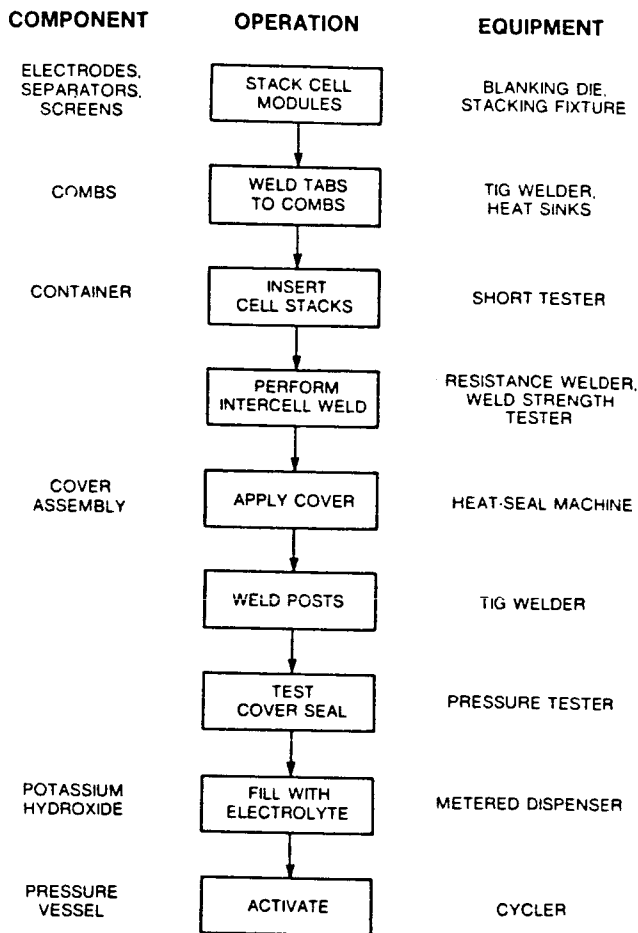

Figure 2 Sequence of operations for assembling the hydrogen/nickel oxide battery including the respective tooling.

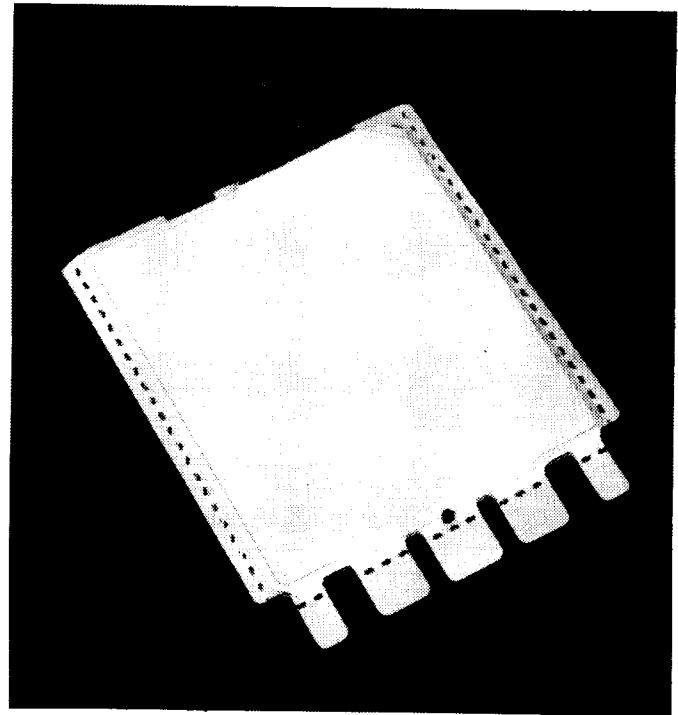

Figure 3 One (1) assembled and sealed cell-module.

ORIGINAL PAGE IS
OF POOR QUALITY

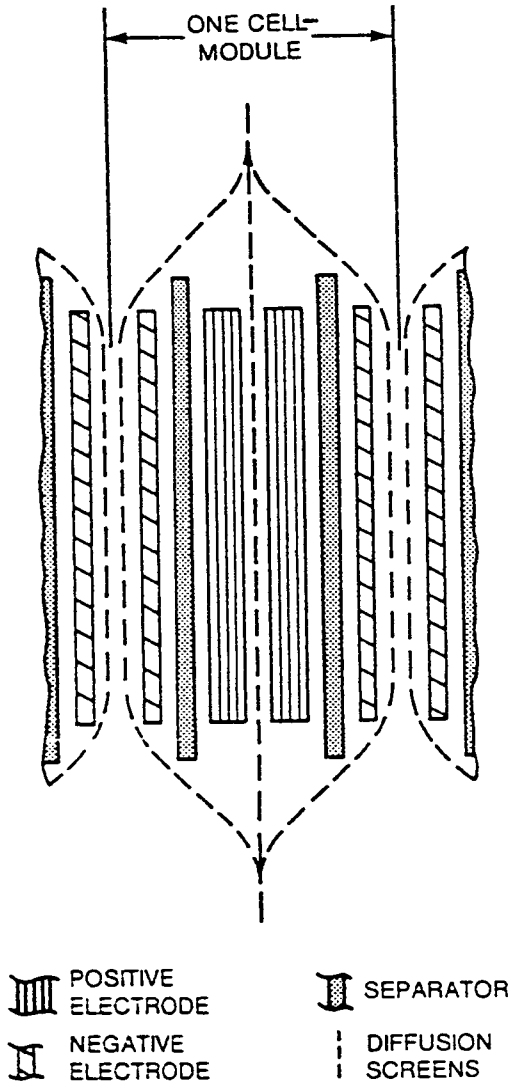

Figure 4 Component stacking arrangement of the cell-module illustrating the diffusion/binding functions of the screen.

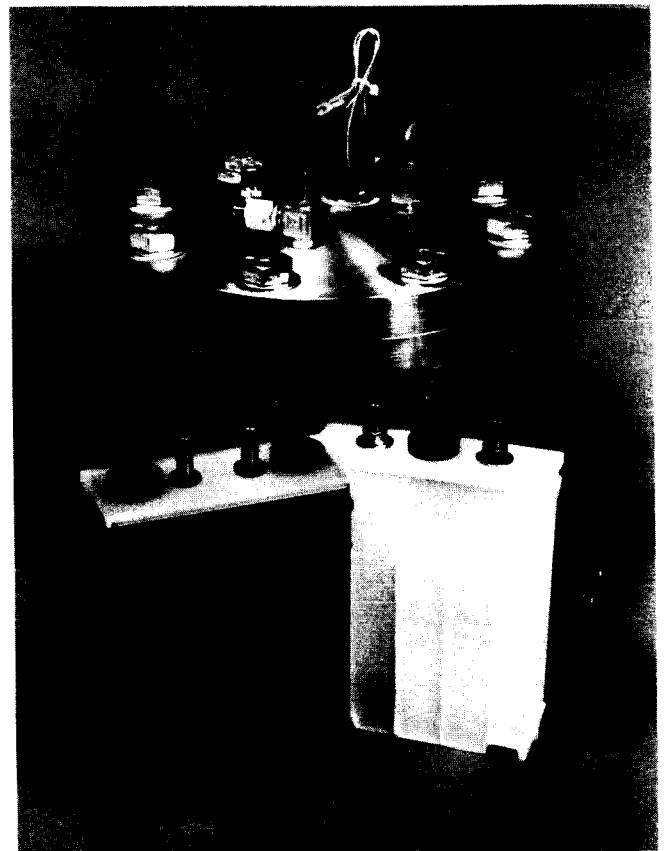

Figure 5 Single hydrogen/nickel oxide cells (3.8 & 5.1 cms thick) and boiler-plate pressure vessel in which lab tests were conducted.

POSITIVE ELECTRODE THICKNESS EFFECT
 70 vs 32 MIL
 10 DEG. CELSIUS

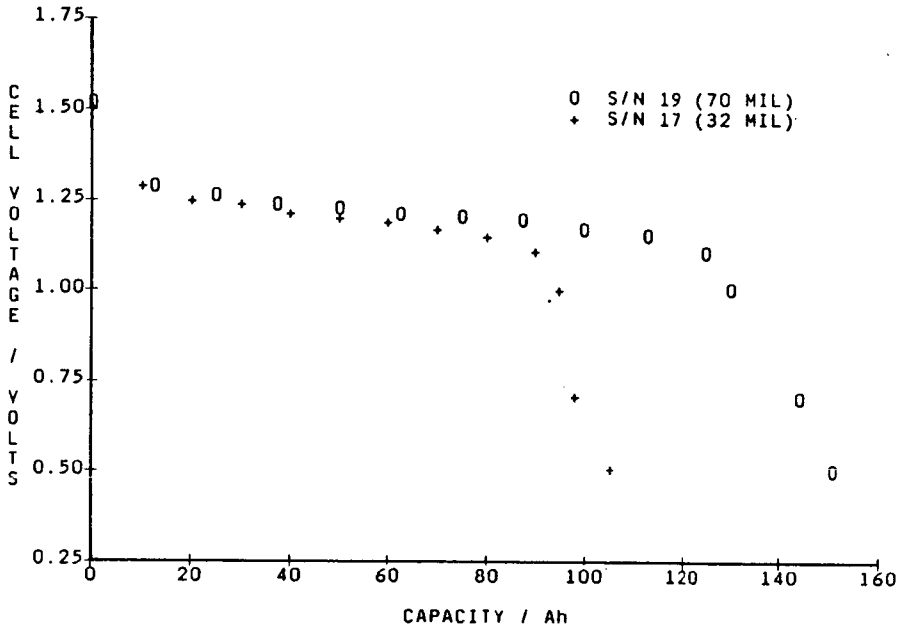

Figure 6 Discharge curves of prismatic cells containing 32-mil and 70-mil thick positive electrodes.

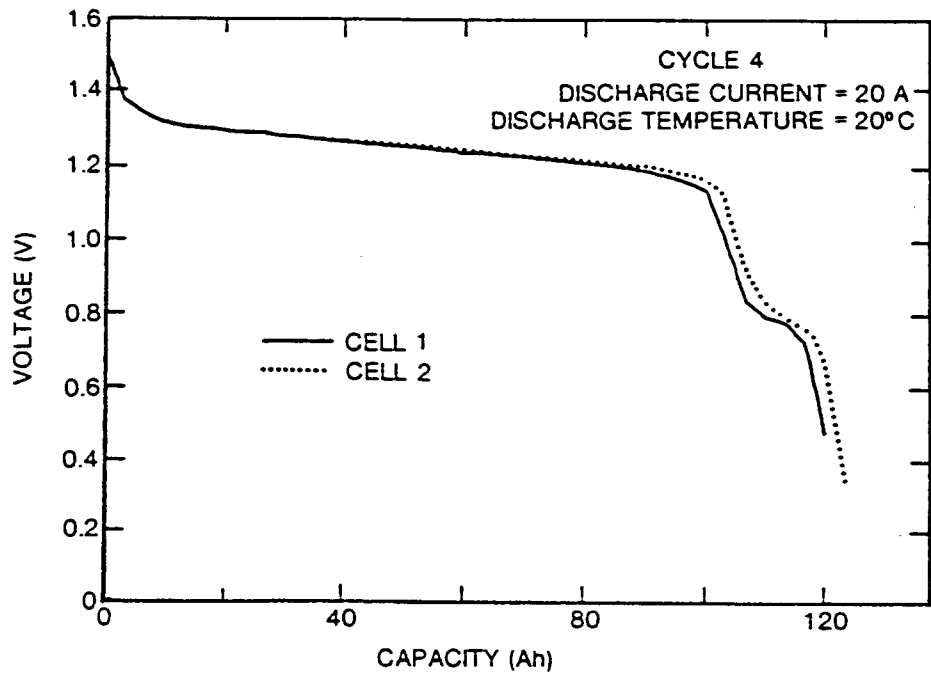

Figure 7 Discharge curves of prismatic cells comparing performances of negative electrodes containing 0.45 mg Pt/cm2 (cell 2) with 8 mg Pt/cm2 (cell 1).

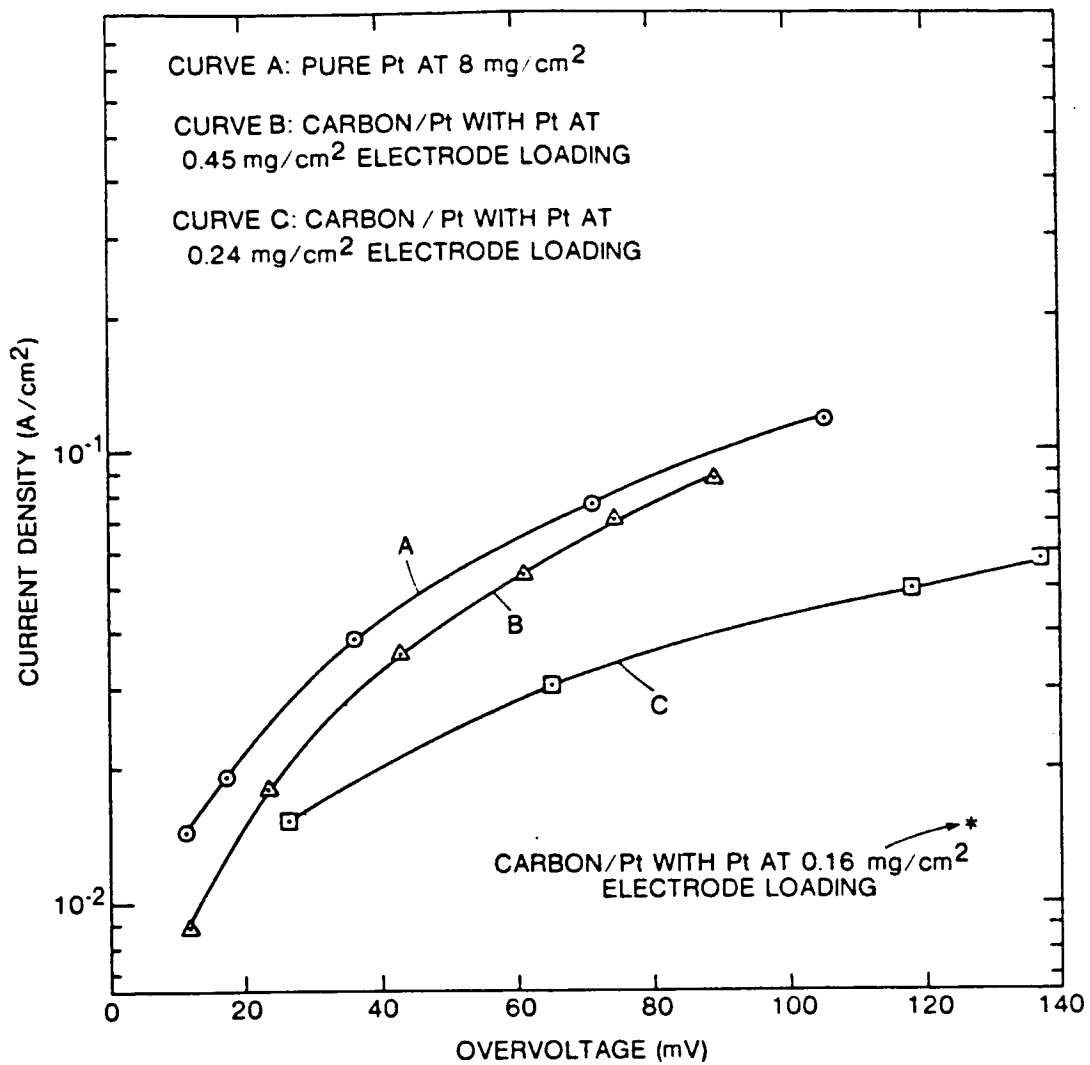

Figure 8 Variation of potential with current density.

POLARIZATION PERFORMANCE OF CATALYST BD5087 NEGATIVE ELECTRODES
VS. PLATINUM LOADING AND SINTERING

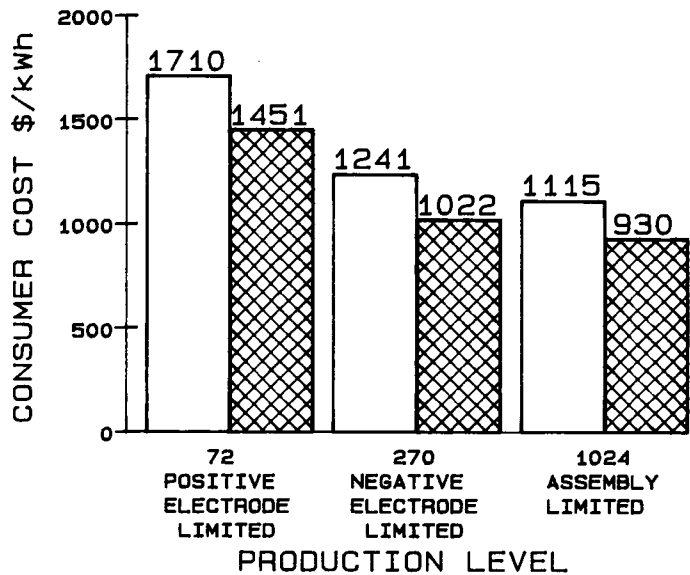
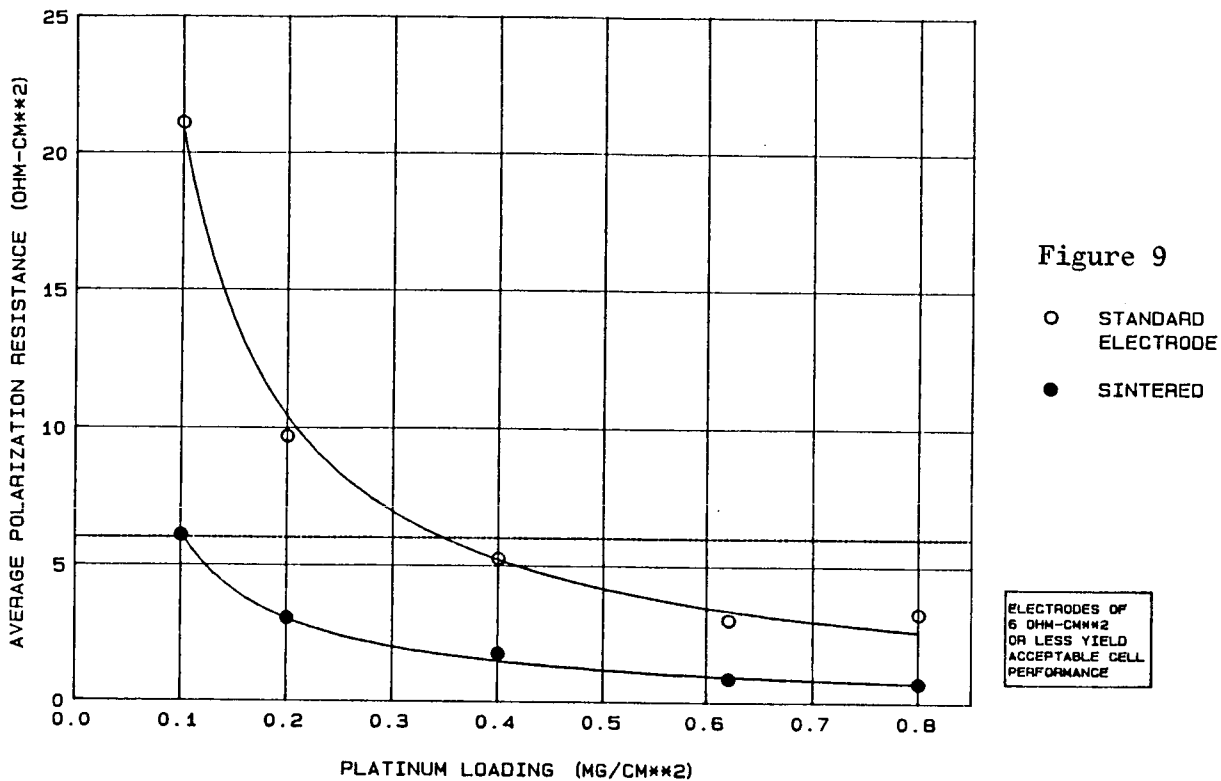

Figure 10 Reduction in cost of a 15 kWh hydrogen/nickel oxide battery as a function of production levels and continued cost reduction efforts.

□ 1984 COST PROJECTION
 ▨ 1986 COST PROJECTION