

NASA Technical Memorandum 4008

Antarctic Field Tests of SARSAT Personal Locater Beacons

Robert Bindschadler
*Goddard Space Flight Center
Greenbelt, Maryland*

NASA
National Aeronautics
and Space Administration
**Scientific and Technical
Information Branch**

1987

TABLE OF CONTENTS

	<u>Page</u>
ACKNOWLEDGMENTS	iv
PURPOSE OF TESTS	1
DESCRIPTION OF SARSAT SYSTEM	1
ANTARCTIC TESTS	2
Test #1: Observation Hill	3
Test #2: South Pole	4
Test #3: Shallow Crevasse	6
Test #4: Snow Trench	6
Test #5: Deep Crevasse	10
Test #6: Snow Bridge	11
Test #7: Homing Capability	12
RESPONSE TIME	13
RECOMMENDATIONS	15

PRECEDING PAGE BLANK NOT FILMED

PRECEDING PAGE BLANK NOT FILMED

ACKNOWLEDGMENTS

This work was very capably assisted by David Lasorsa, a Snow Survival School instructor stationed in McMurdo. David provided information on appropriate locations for each test and supervised the safety of the work in the vicinity of the crevasses. Ens. Robert Borgerding provided liaison with the Communications Office in McMurdo for the proper handling and documentation of the alert messages. The assistance and interest of Wayne Hembree and Morton Friedman of NASA/GSFC was instrumental in initiating this study and making available the loan of the two PLBs used. The National Science Foundation, Division of Polar Programs provided all necessary logistical support. Hugo Hodge of Westinghouse provided the count data of the C2 and C3 satellites.

ANTARCTIC FIELD TESTS OF SARSAT PERSONAL LOCATER BEACONS

PURPOSE OF TESTS

In January 1987, tests were conducted in Antarctica to assess the utility of the SARSAT Personal Locater Beacon (PLB) for use by Antarctic field parties. In Antarctica there is a definite need for a reliable emergency notification capability, given the harshness of the environment, the remoteness of field parties and the large distances which often exist between rescue forces and field parties. The present radio communication network in Antarctica can experience problems and the safety of field parties should not be compromised if a more reliable emergency procedure can be established.

DESCRIPTION OF SARSAT SYSTEM

The SARSAT (Search And Rescue Satellite Aided Tracking) system consists of a set of dedicated polar orbiting satellites and a network of ground stations (both receiving and relaying) communicating to rescue centers. When activated, transmitters (such as the PLB) emit a 406 MHz signal every 50 seconds which is received by any SARSAT satellite in view. The precise frequency received by the satellite is shifted due to the motion of the satellite; the Doppler effect. In addition to measuring the frequency versus time, the satellite also collects a digitized message from the transmitter. These data are transmitted to receiving ground stations which come into view of the satellite as it continues to orbit. The magnitude and time variation of the frequency shift is used on the ground to calculate the transmitter's position relative to the known orbital position of the satellite.

From a single satellite pass, there is an ambiguity of PLB position because the data cannot discriminate with certainty whether the PLB is on the right or left of the satellite track. Thus, the first alert for any PLB provides two possible locations (and a probability for each). The next pass, however, resolves this ambiguity and generates a composite solution of the PLB position. Subsequent passes contribute to the refinement of this composite position. Each alert message after the first contains the composite solution as well as the most recent individual pass solutions of position (up to a limit of five). For the analysis presented here, each position is treated as independent and no use is made of the composite solution.

A unique identification code is included in the transmission of each beacon. This unique identification code permits checking for false alarms prior to committing SAR forces and also discriminates multiple beacons in the same area. The routing of the alert notification is determined by the U.S. Mission Control Center at Scott Air Force Base in Illinois and is based on the location of the beacon. In addition to PLB location, each alert notification includes information on the PLB identification number, the time of closest approach by the satellite, the detecting satellite and orbit number, the receiving ground station, and the time Scott AFB routed the alert to the appropriate rescue center. In most cases, this routing is done automatically over computer communication lines.

For the Antarctic tests, the assigned rescue center was McMurdo Station, Antarctica. At the Mission Control Center at Scott AFB, alerts received from the Antarctica PLBs automatically initiated a top-priority message on the U.S. military Autodin system, routed for the Communications Officer of the Naval Support Force for Antarctica (VXE-6) in McMurdo Station, Antarctica. Upon receipt of such an alert, U.S. rescue forces could immediately be sent to the indicated location.

The PLBs also transmit a 121.5 or 243 KHz signal as a homing signal for rescue aircraft. All U.S. military and civilian rescue aircraft receive either one or both of these frequencies. The mean accuracy of the Doppler fix is approximately 5 kilometers and the range of the homing signal about 15 to 20 kilometers, depending on search aircraft altitudes. Thus, even for situations where the distress victim cannot be seen, once rescue forces are on-site at the satellite-calculated position, they can home-in on the exact location.

ANTARCTIC TESTS

Two PLBs were loaned by the SARSAT Project Office at NASA Goddard Space Flight Center for the Antarctic tests. These PLBs have the unique identification codes ADCF004070C0401 and ADCF00406CC0401 (hereafter referred to as 407 and 406, respectively.) Each PLB transmitted its signal with 2 watts of power and each was tested to operate continuously for over 24 hours at -20°C . Each measured approximately $3\text{ cm} \times 7\text{ cm} \times 14\text{ cm}$ and had a 15cm-long whip antenna. The antenna was held down by a Velcro flap which, when removed, activated the PLB.

The computer at Scott AFB was programmed to route the alerts for these two beacons to McMurdo Station during the testing period. The Communications Office at McMurdo was informed of all testing undertaken and provided copies of the received messages to the test supervisor.

The series of tests was designed to examine two specific questions:

1. what is the PLB performance in possible Antarctic rescue situations, and
2. what is the response time between PLB switch-on and notification at McMurdo Station.

The availability of two test PLBs permitted the use of one as a control on the surface with as unobstructed a view of the horizon as possible (optimizing the visibility between PLB and any satellite), while the second PLB was placed in a more obstructed position. Each test was run for a number of hours to collect a succession of satellite passes with different geometries (azimuth of satellite travel and inclination above the horizon).

Seven separate tests were conducted. In each case, the control PLB was vertical on the surface. The particular situation for the second PLB was as follows:

- TEST #1: horizontal (Observation Hill, McMurdo Station)
- TEST #2: shallow trench in cold, dry snow (South Pole)
- TEST #3: 2.5 meters deep in crevasse (icefall, McMurdo Station)
- TEST #4: snow trench in warm snow (Williams Field)
- TEST #5: 7.5 meters deep in crevasse (icefall, McMurdo Station)
- TEST #6: below snow bridge (icefall, McMurdo Station)
- TEST #7: Homing capability of VXE-6 helicopter

What follows is a more detailed description of each test, including the objective, discussion of the data gathered, and the conclusions. The data for each test are represented by two figures; one which displays the azimuth of travel and maximum elevation angle above the horizon of each satellite pass during the test, and another which plots the PLB locations which were calculated from each pass. The passes are ordered by time of alert receipt at McMurdo Station. During the tests, there were only four active satellites receiving and relaying alerts: two American (S2 and S3) and two Russian (C2 and C3).

For the two Russian satellites there was additional information on the visibility between the PLB and the satellite which was collected and stored at the receiving station at Goddard. The visibility was quantified by the number of separate transmissions (one transmission every 50 seconds) received by the satellite from each PLB on any pass. This number, termed 'counts', could be a theoretical maximum of about 20 for an unobstructed, high-elevation pass. In general, the higher the number of counts, the better the location accuracy. These count numbers are included in the figures for each test for the passes of C2 and C3. Unfortunately, these same data were not saved for S2 and S3.

Test #1: Observation Hill

Objective: Initial test and measure of performance degradation by horizontal antenna.

Observation Hill, at the outskirts of McMurdo Station, was chosen as the site for the initial test. The snow-free summit provides an almost unobstructed view of the horizon. In this test, PLB 407 was set vertically while PLB 406 was laid horizontally with the antenna pointing at a true bearing of 90° E. Midway through the test, PLB 406 was rotated an additional 90° (i.e., pointing toward true South).

The air temperature was measured at -1° C.

This was a short test; data from only six passes were collected. Figure 1 shows that for one of these passes, C2 did not receive adequate data from PLB 406 to calculate a position. For this pass the azimuth of PLB 406 was true South. For all other passes, however, a location accurate to ± 3 kilometers resulted. Usually the independent locations determined for the two PLBs agreed to within 2 kilometers. The position of Observation Hill as read off a map of the McMurdo area was in agreement with the locations from SARSAT.

Results: The system provides accurate locations but there is a suggestion that reliability will decrease if the antenna is horizontal.

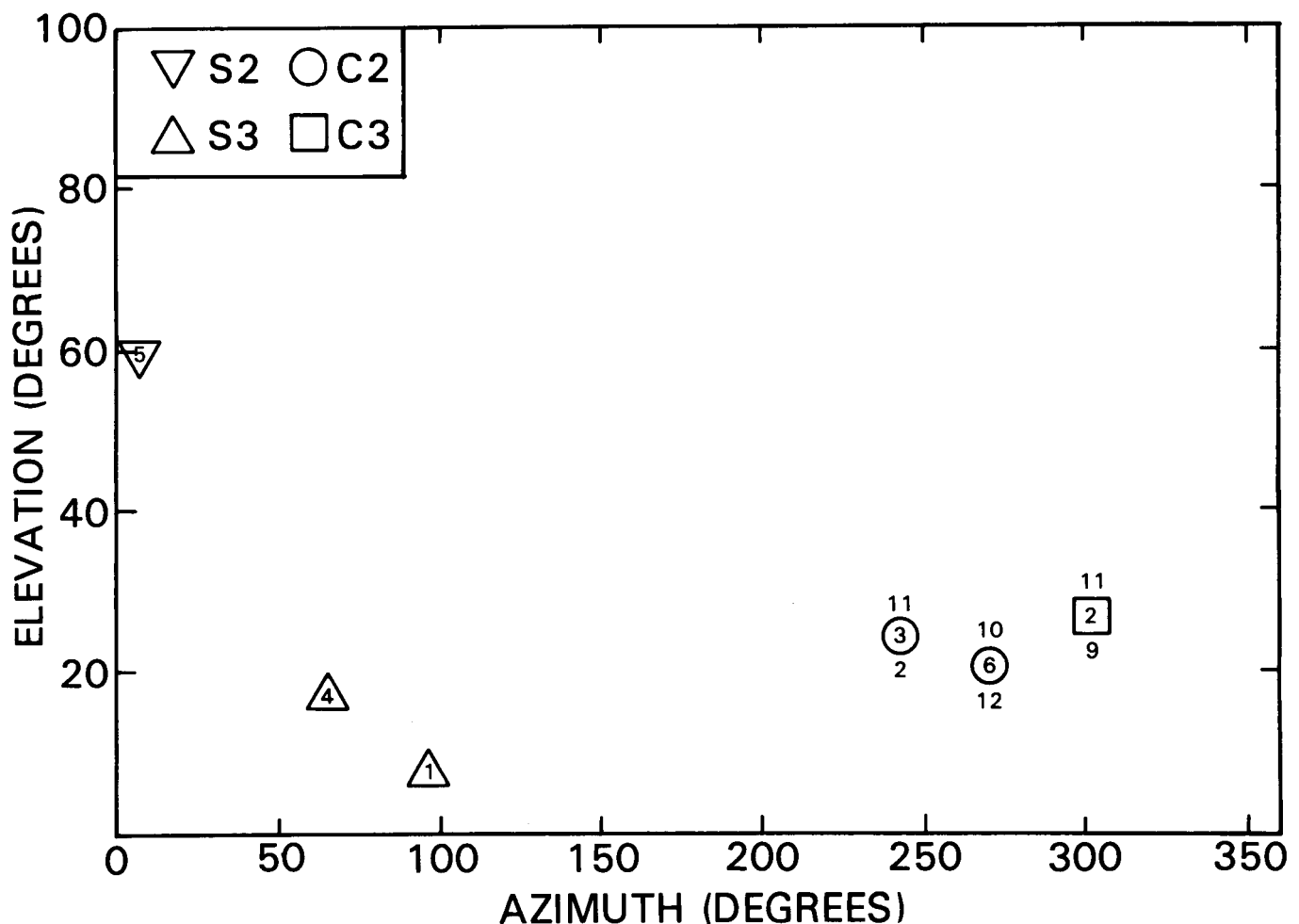

Figure 1. Passes for all operational SARSAT satellites which occurred during Test #1. Azimuth and elevation above horizon correspond to the point of closest approach to the PLB. Number within symbol gives order in which alerts were received in McMurdo. Numbers above and below C2 and C3 passes correspond to counts received by the control and test PLB respectively. The count data were not available for S2 and S3.

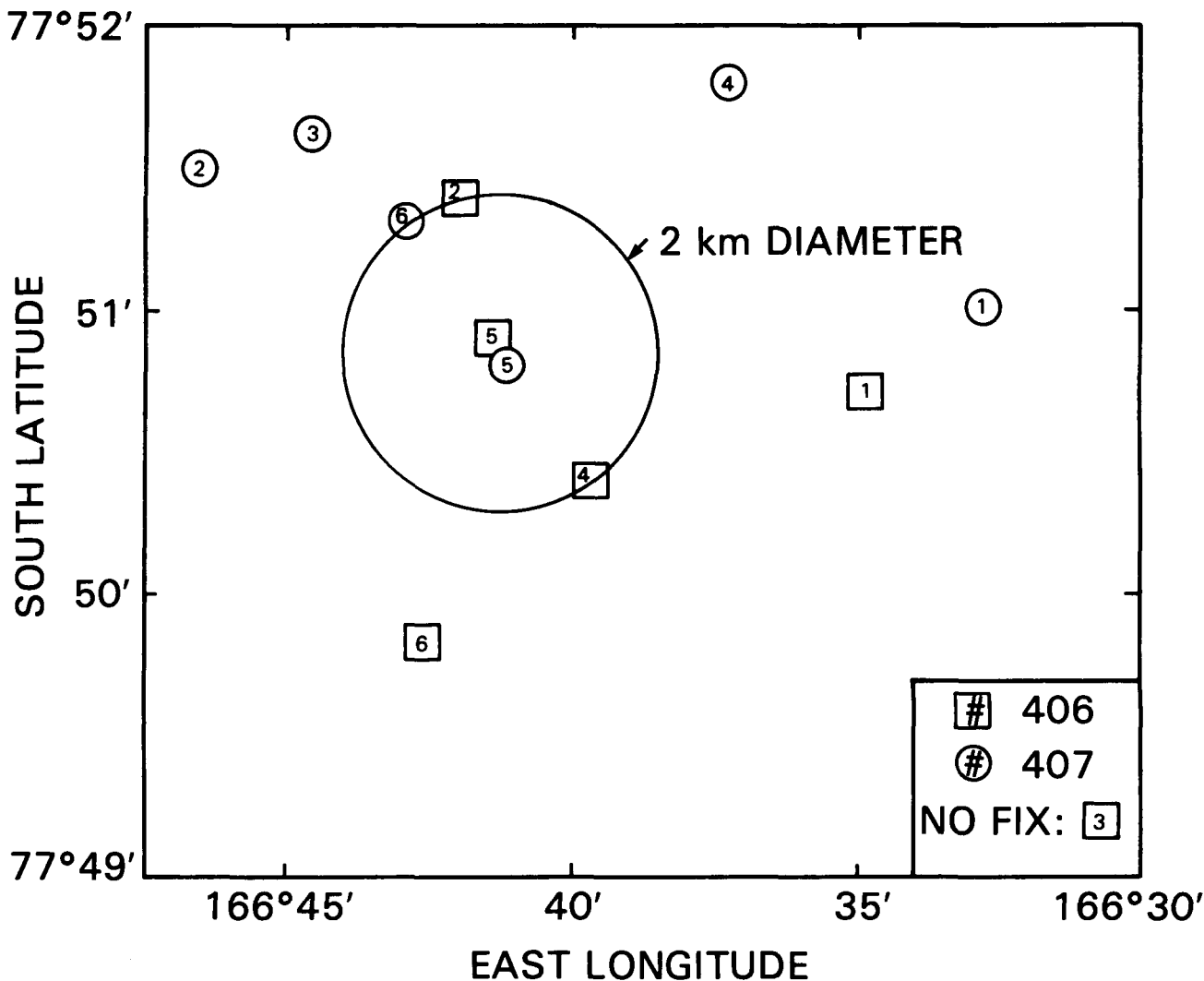

Figure 2. Locations calculated from each SARSAT pass for each PLB during Test #1. Numbers within symbol correspond to numbers in symbols in Figure 1 (i.e., order of alert receipt in McMurdo). Passes with no fix obtained are also noted.

Test #2: South Pole

Objective: Investigate SARSAT performance at the unique geometry of 90° South and test visibility of the PLBs through dry snow.

Because the SARSAT satellites are in near-polar orbits the regions near the poles are unique; it was desirable to study the location accuracy for this situation. The opportunity to conduct a short test at the South Pole was seized by traveling on a VIP flight to South Pole, however, the time spent on the surface at South Pole Station was limited to only 3 hours. For this test, PLB 407 was placed in a shallow trench 0.1 meter wide by 1 meter long by 0.4 meter deep dug with an ice ax. The location was within 200 meters of the sign marking the geographical South Pole. PLB 406 was placed on the surface next to the trench. Both beacons were vertical. The air temperature was -19°C. The density of the surface snow was 356 kg/m³.

Six passes occurred during the test. Figure 3 shows that most passes had low elevation angles and fewer counts for the PLB in the trench. Figure 4 demonstrates that the locations of the surface PLB were well clustered while the consistency of locations of the trench PLB was significantly worse (19 kilometers from the South Pole in two of the six cases). The one case where both the surface and trench PLB were poorly

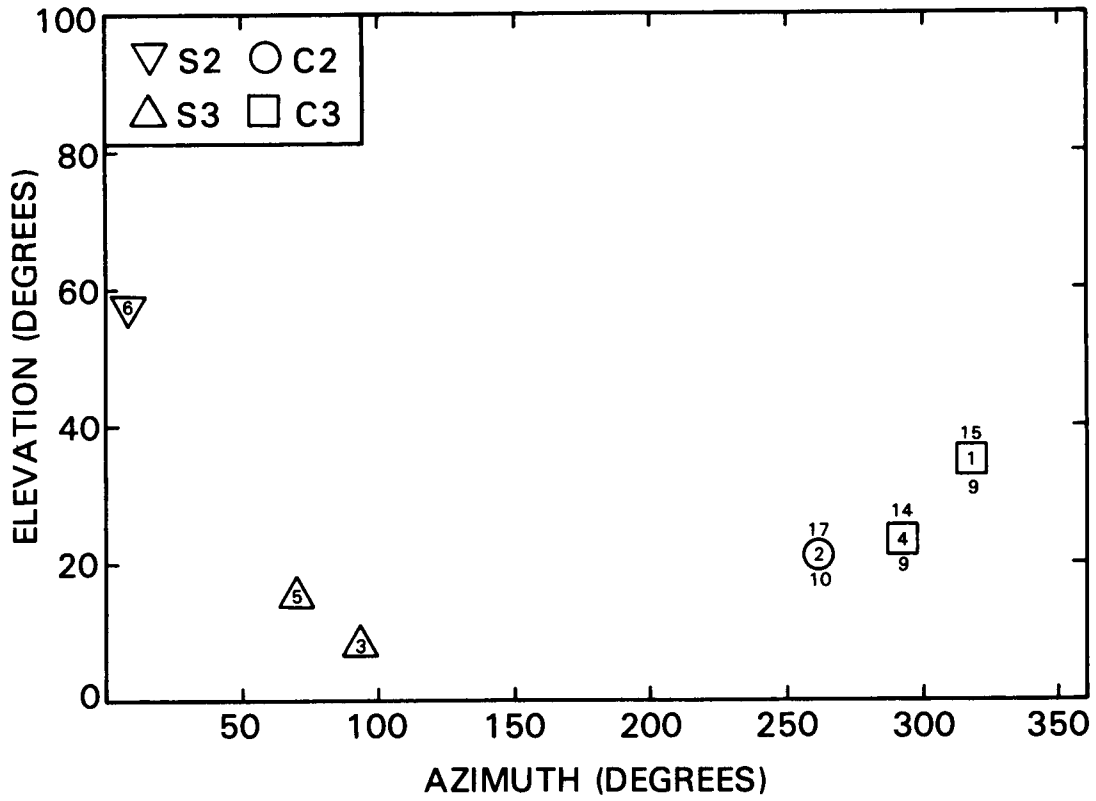

Figure 3. Pass geometries during Test #2. Explanation of symbols is identical to Figure 1.

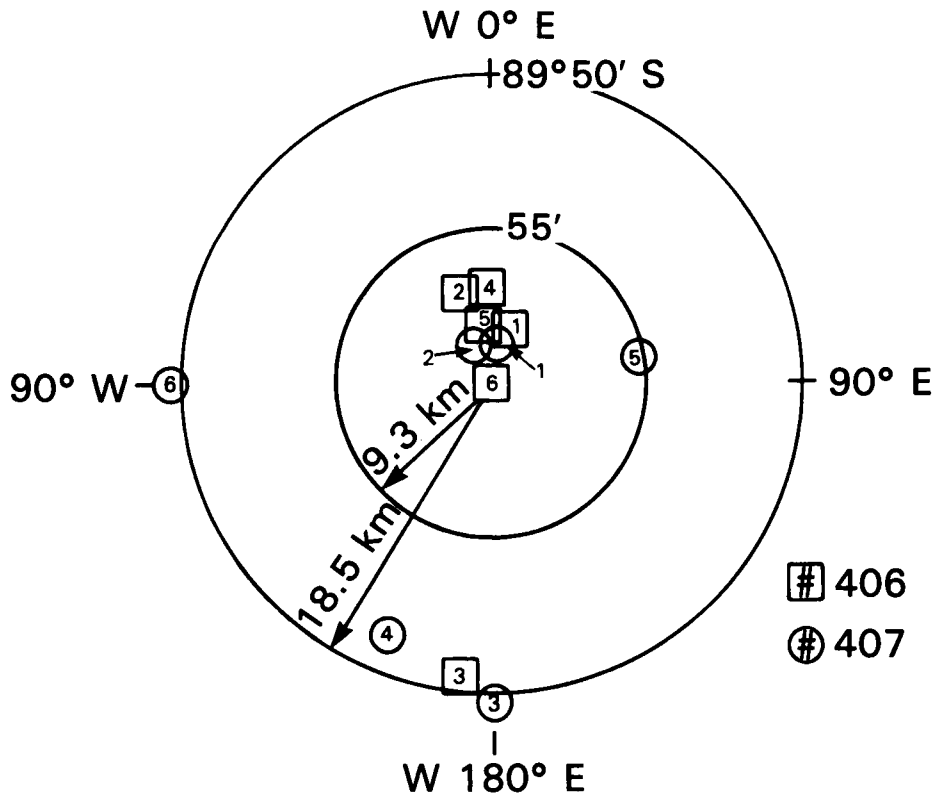

Figure 4. Calculated PLB locations for Test #2. Numbers within symbols correspond to numbers in symbols in Figure 3.

located was the lowest elevation pass (8 degrees above the horizon). Even the accuracy of the surface PLB was somewhat worse than the 2 kilometers of Test #1. This may be a result of the low elevation of each pass.

The cluster center did not coincide with the location of the South Pole, but was displaced 3 to 4 kilometers from it on a bearing of approximately 0° true. Whether this discrepancy is real or a result of an error in the location of the sign indicating the location of the true South Pole is not known. In any case, these errors are not significant for anticipated rescue operations in this area.

Some of the data used for the poor locations passed through the snow but there is no strong correlation between pass azimuth and location accuracy. There is no apparent reason for the poor location for pass #4, when passes #1 and #2 with similar geometry were so good.

Results: SARSAT works acceptably well at the South Pole, however, transmission of the PLB signal through dry snow can significantly affect the accuracy of the calculated PLB location.

Test #3: Shallow Crevasse

Objective: Investigate SARSAT performance with PLB suspended in a crevasse.

An icefall region on Ross Island used by the Snow Survival School was chosen as the site for this test. PLB 407 was lowered 2.55 meters below the surface into a crevasse. The geometry of the crevasse was relatively simple: approximately 2.5 meters wide with a relatively straight North-South orientation for a distance of at least 10 meters in each direction. The PLB was lowered from the west side of the crevasse and hung very near, but not touching, the west wall of the crevasse. PLB 406 was again placed on the surface next to the crevasse. The air temperature was $+2^\circ\text{C}$ at the beginning of the test and fell to 0°C when the test concluded $6\frac{1}{2}$ hours later. Beside the crevasse, the surface snow density was measured to be 362 kg/m^3 .

Data from 14 passes (numbered 3 through 16) were collected. This provided a wide range of pass azimuths and elevation angles as Figure 5 shows. All of the surface PLB locations except one occurred within a 1.5 kilometer radius area (see Figure 6). By contrast, the crevasse PLB was not located at all in five cases. Figure 5 shows that these five cases correspond to the five cases of lowest elevation angle. This strongly suggests that the PLB will never be located when the signal must penetrate a significant depth of warm snow. While the snow conditions did not appear to be excessively wet, the above-freezing air temperature probably contributed significantly to the obscuration of the crevasse PLB because even small amounts of water strongly attenuate energy at the 406 MHz frequency.

On passes for which the crevasse PLB was detected, the locations were as good for this PLB as for the surface PLB. This is particularly apparent for passes #11, 12 and 13 where there were only five counts collected for the crevasse PLB but 14, 15 and 16 counts (respectively) received from the surface PLB. This is probably due to the fact that the counts received from the crevasse PLB were most likely to occur at the highest elevation when the Doppler shift in frequency was greatest: it is these counts which are most significant in calculating an accurate position.

Results: PLB visibility in a crevasse is limited to the higher elevation portion of any pass. Passes which do receive signal from a PLB in a crevasse can be as accurate as an unobstructed PLB. The PLB signal appears to be severely attenuated by melting snow.

Test #4: Snow Trench

Objective: Control visibility of PLB by constructing snow trench with specific geometry based on predicted pass geometry.

It was possible to predict the pass geometry of each pass by using an orbit prediction table provided by Friedman (NASA Technical Memorandum 85015). From these known passes a snow trench was designed which could obscure the PLB in the trench from particular passes for predictable lengths of time. The test,

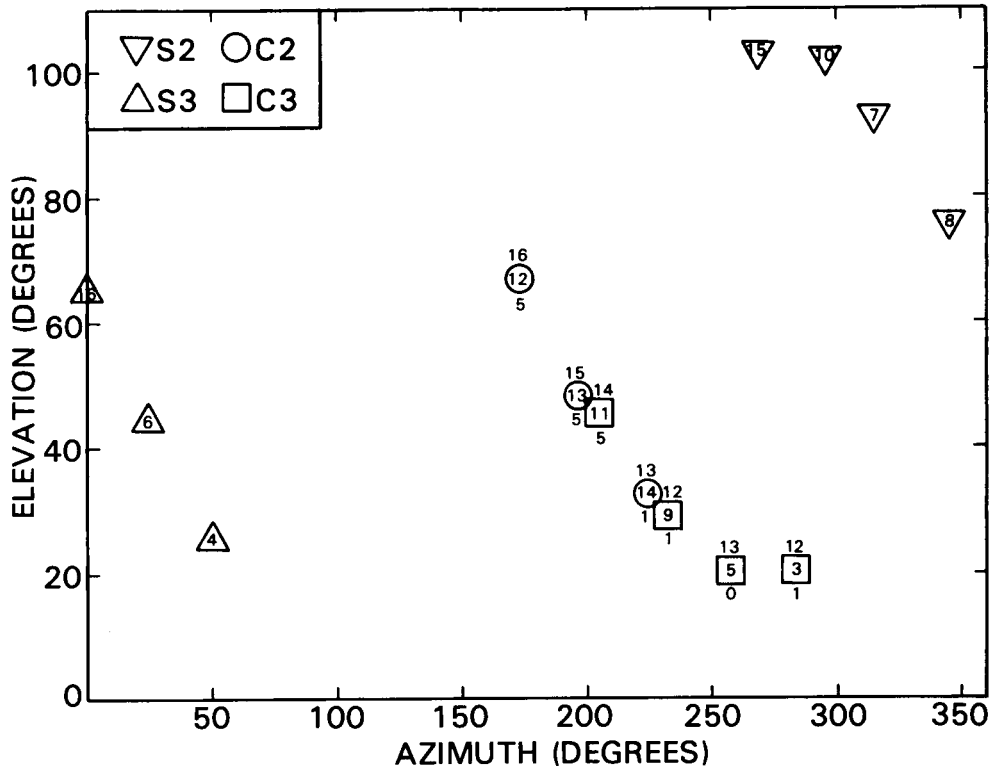

Figure 5. Pass geometries during Test #3. Explanation of symbols is identical to Figure 1.

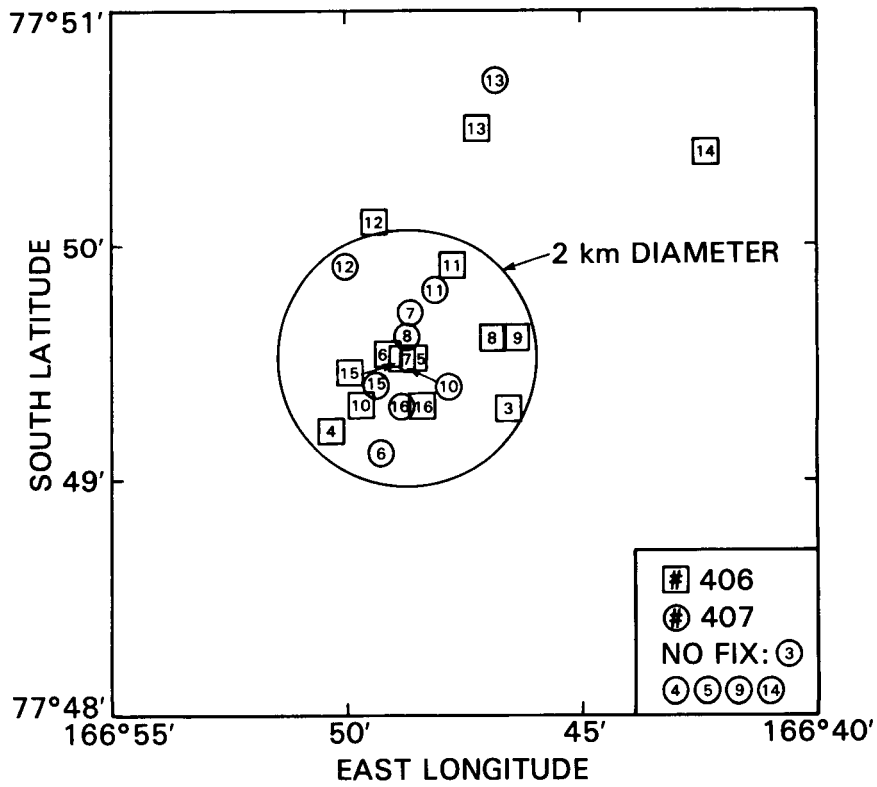

Figure 6. Calculated PLB locations for Test #3. Symbols are as described in Figure 2.

which lasted 9 hours, collected a large number of different pass geometries (see Figure 7). The particular geometry of the trench is diagrammed in Figure 8.

The site of the test was near Williams Field IV on the McMurdo Ice Shelf. A trench of the specified dimensions and orientation was dug with shovels. The temperature at the bottom of the trench (0.67 meters below the surface) was -1°C . The snow density measured in the side of the trench was 448 kg/m^3 .

Low elevation passes at azimuths between 250 and 360 degrees were designed to be obscured the maximum amount. Figure 9 shows that, indeed, these passes constituted the majority of passes for which the position of PLB 407 in the trench was either not calculated or was rather poor. Passes #11 and 13 are notable exceptions to this trend. Many of the other cases required partially obscured signals, but the positions for nearly all passes cluster within a 1.5 kilometer radius circle. This suggests that transmission of the PLB signal through a limited distance of snow is possible. This snow was more dense than the snow in Test #3. It is believed that the more important parameter for signal attenuation is the presence of liquid water from melting snow.

Result: At sub-freezing temperatures, the PLB signal can be transmitted through a short distance of snow without adversely affecting the accuracy of the position calculation.

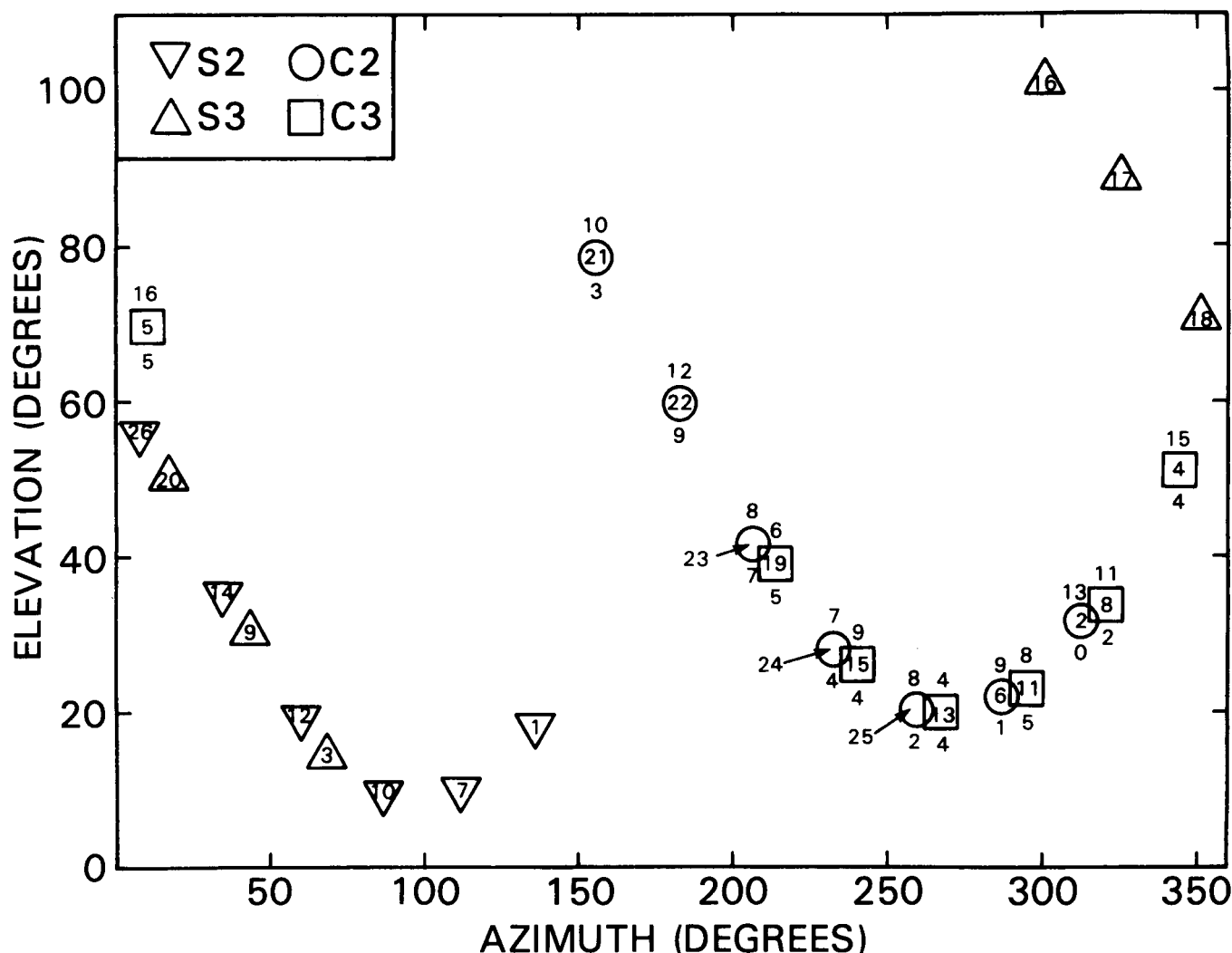

Figure 7. Pass geometries during Test #4. Explanation of symbols is identical to Figure 1.

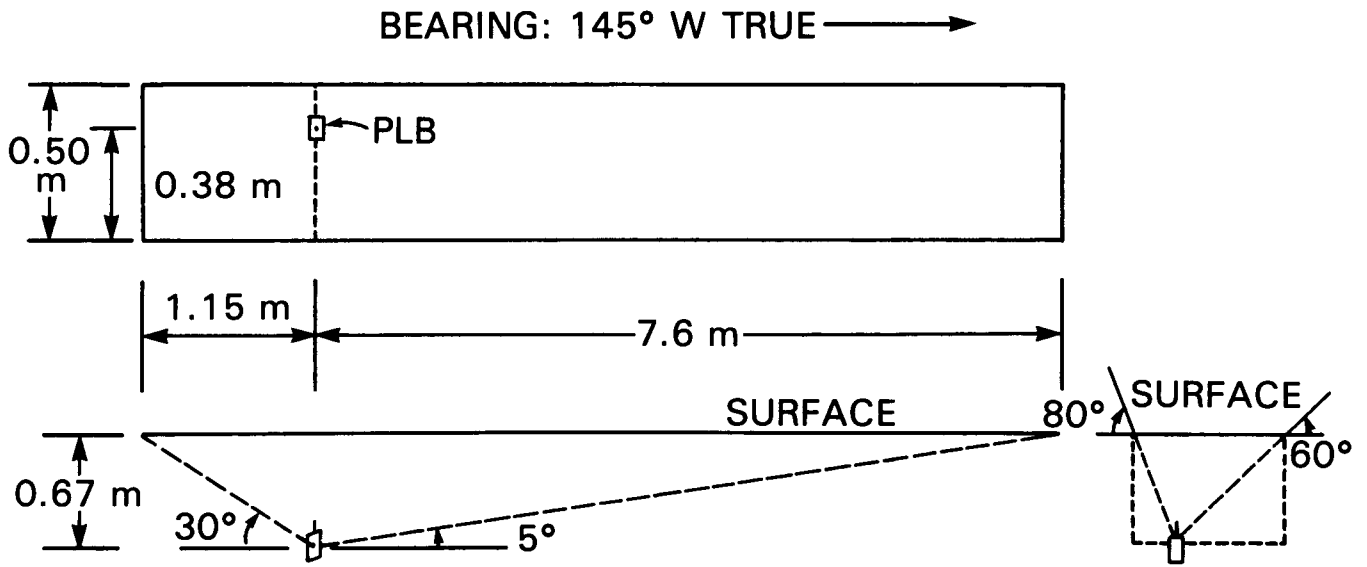

Figure 8. Geometry of snow trench used in Test #4.

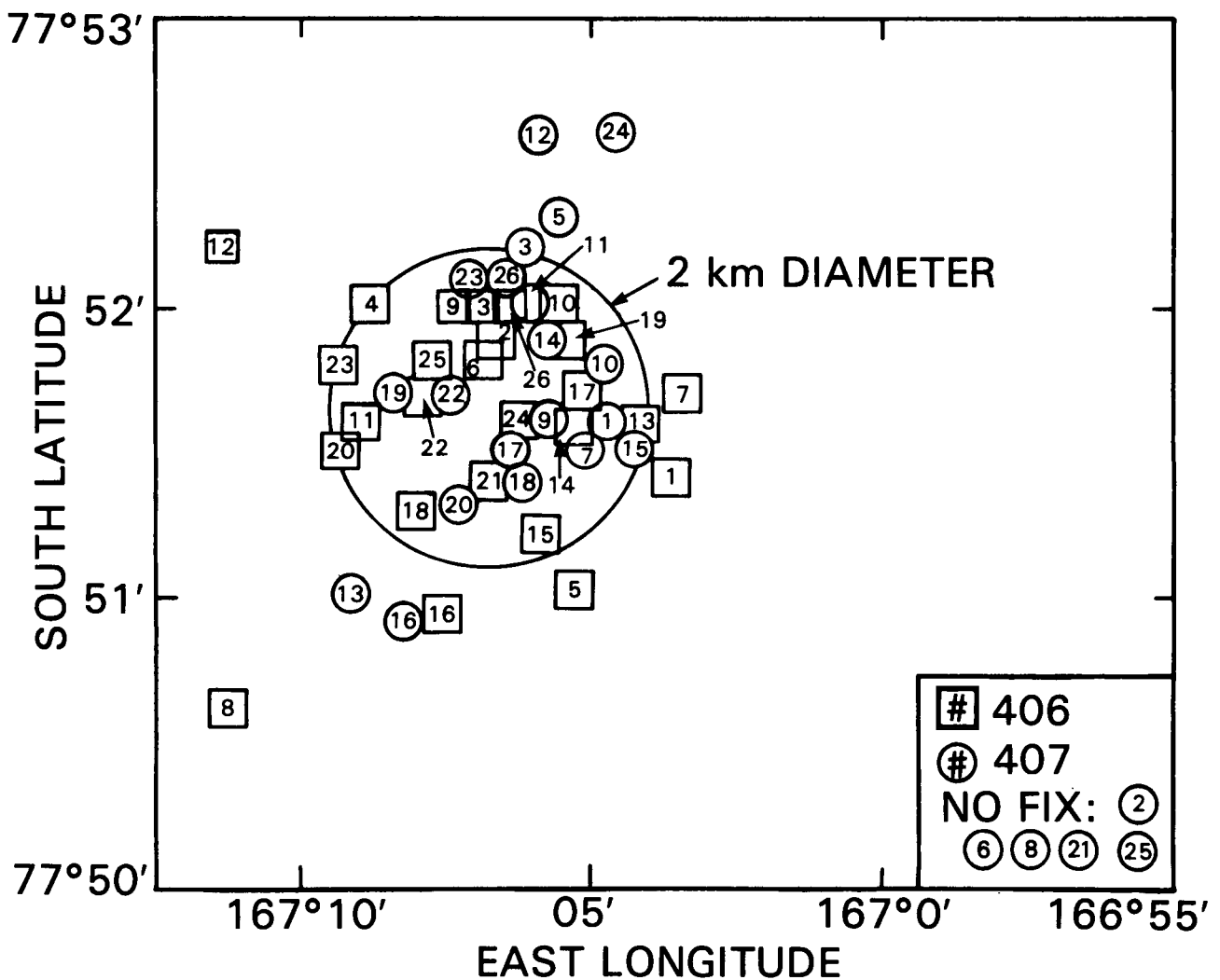

Figure 9. Calculated PLB locations for Test #4. Symbols are as described in Figure 2.

Test #5: Deep Crevasse

Object: Study performance of PLB suspended deeper in a crevasse.

For this test, the same crevasse as was used in Test #3 was used again but PLB 407 was lowered to a depth of 7.5 meters below the surface at the same location as in Test #3. PLB 406 was again placed on the surface at the same location as the previous crevasse test. Figure 10 shows that even the geometry of the satellite passes was approximately the same as for Test #3. While the temperature was not measured, it was estimated to be slightly above freezing as in Test #3.

For a large number of passes the satellites were unable to detect either the presence or the location of the PLB in the crevasse. With one exception, this was true of all passes with elevations below 20 degrees or azimuths between 240 and 350 degrees. The one exception, pass #9, provided an acceptable position but it is not known how many counts were collected on this pass by either PLB.

Another comparison between this test and Test #3 is that the clustering of positions which were calculated is considerably worse for this test than for the earlier test. This fact holds true for both the surface PLB as well as the one in the crevasse. There is no obvious explanation for this, as the same PLB was left at the same spot for the same period of the day with similar passes occurring. A possible cause is differences in the atmosphere on the 2 days which would affect the travel path of the signal to the satellite.

Result: The deeper in a crevasse the PLB, the less likely an alert. There also appears to be daily variability in the accuracy with which the position of PLBs is calculated.

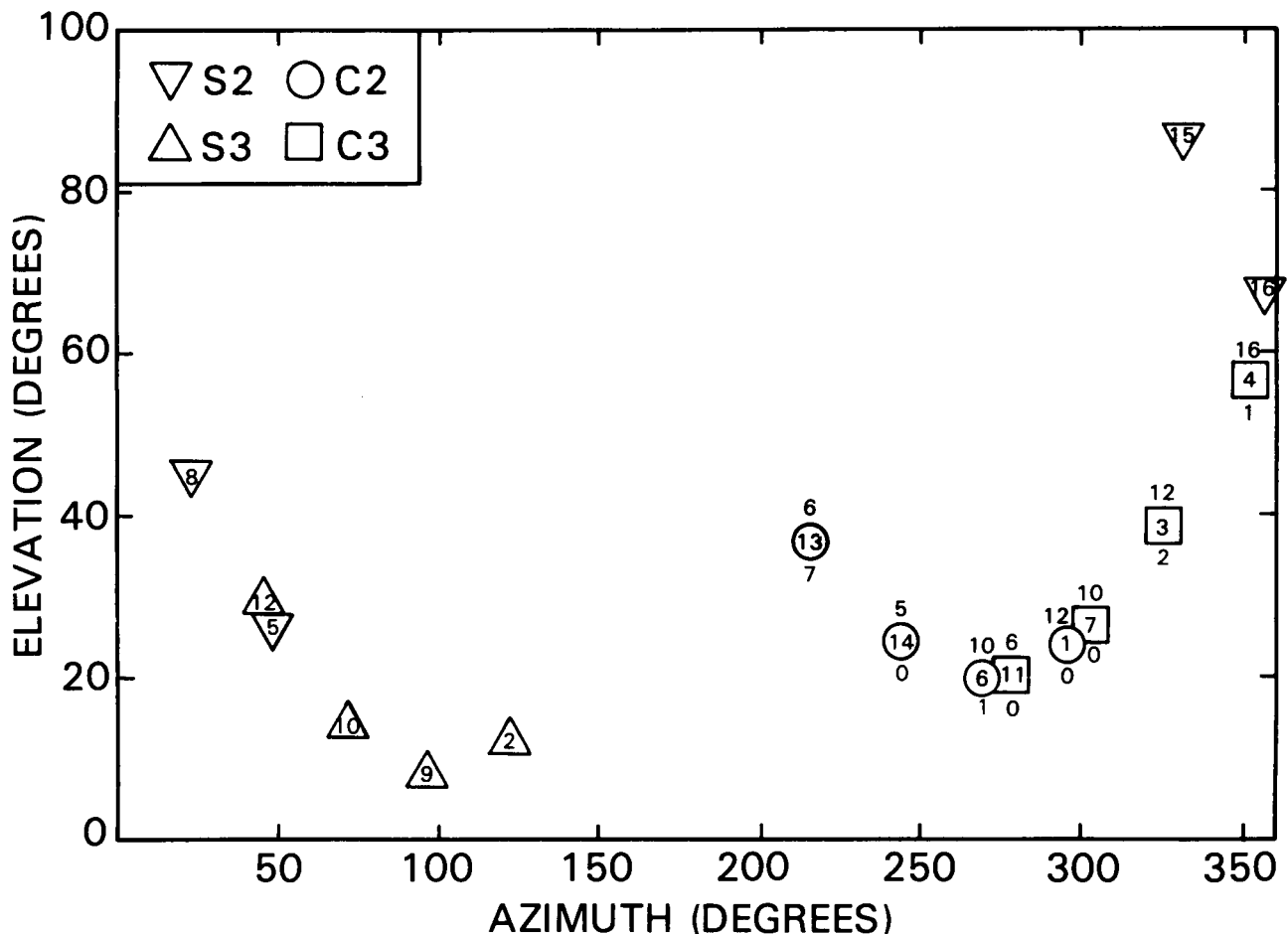

Figure 10. Pass geometries during Test #5. Explanation of symbols is identical to Figure 1.

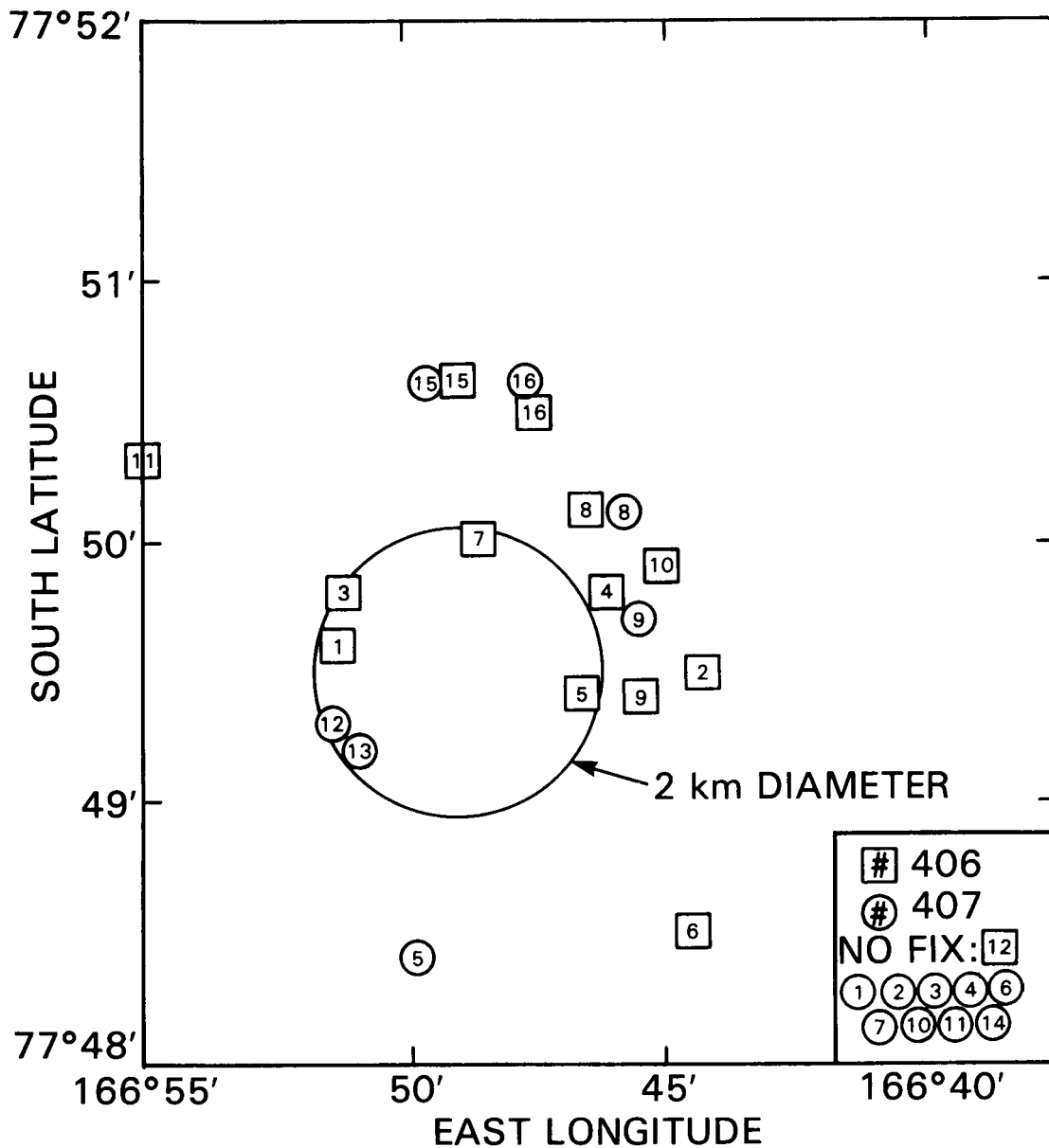

Figure 11. Calculated PLB locations for Test #5. Symbols are as described in Figure 2.

Test #6: Snow Bridge

Objective: Study performance of the PLB when suspended in a shallow crevasse but underneath a snow bridge.

A set of small bridged crevasses was found on the McMurdo Ice Shelf. The crevasse used was generally about 1 meter wide at the surface and 2 meters deep. The rough orientation of the crevasse was 10°E true. A small hole was made in the 0.3 meter thick bridge and PLB 407 lowered to a depth of 1.3 meters. As before, PLB 406 was set vertically on the surface. Figure 12 gives the characteristic satellite geometry for this test. The surface air temperature was not measured but was estimated at slightly below freezing.

Of the passes for which count data are available, only pass #17 is atypical in that a large number of counts were received from the suspended PLB. In all other cases, only a few counts were received from this PLB. In the majority of these cases a position was calculated for each PLB, but for PLB 407 the position

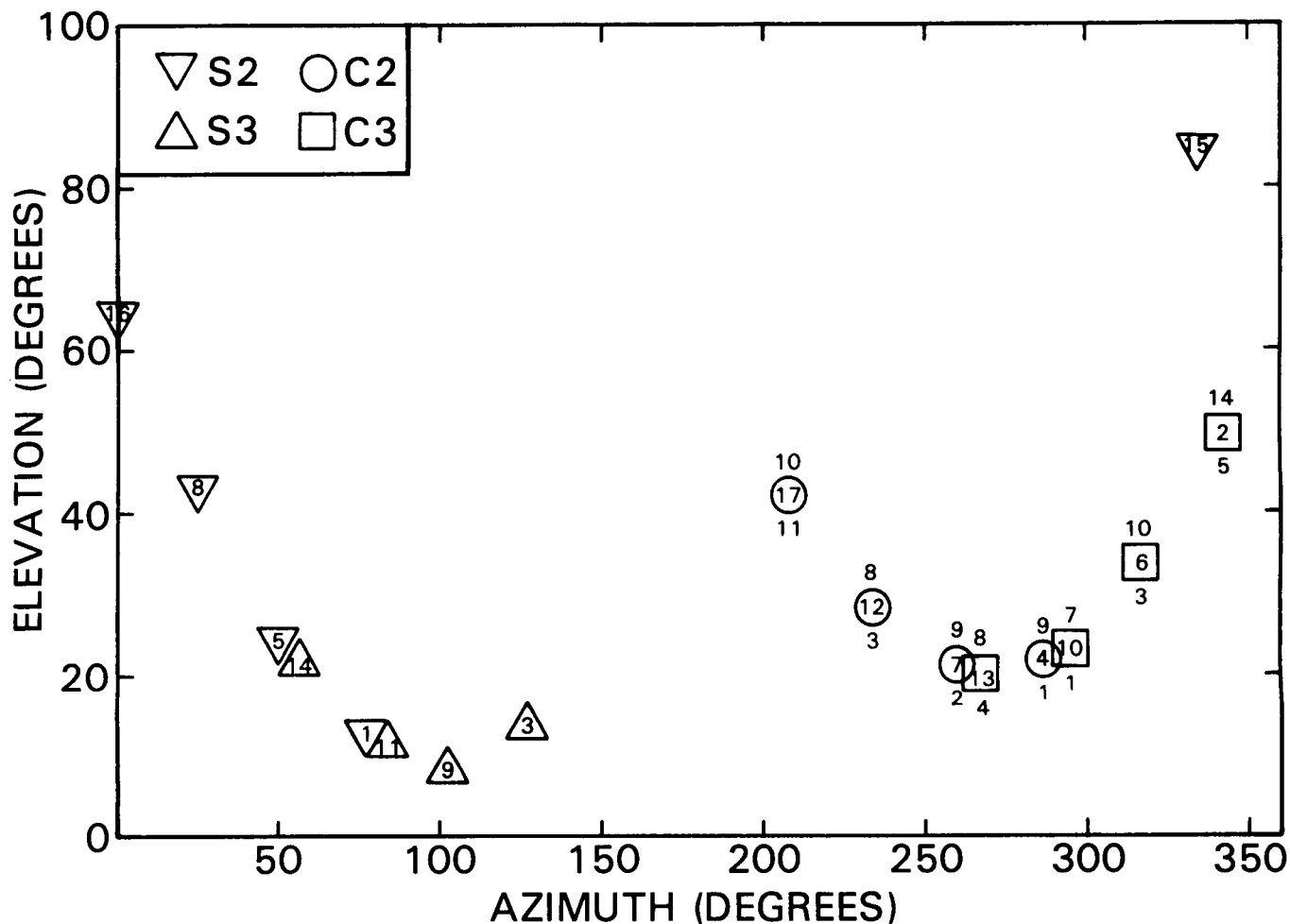

Figure 12. Pass geometries during Test #6. Explanation of symbols is identical to Figure 1.

was usually quite poor (see Figure 13). The bulk of the surface PLB positions are clustered within a 1.5 kilometer radius, while the suspended PLB position varied greatly. In four cases, no position was calculated for the crevasse PLB.

Result: In most cases a PLB will not be detected if it lies below even a thin snow bridge.

Test #7: Homing Capability

Objective: Test ability to locate PLB using PLB homing transmitter.

As part of Test #6, the surface PLB was covered, and a helicopter was requested to locate the unknown position of the PLB using the on-board homing receiver. The helicopter began from Scott Base, approximately 1.5 kilometers from the site of Test #6. The pilots reported no difficulty in detecting the homing signal and vectoring in on its position from numerous directions. They reported being able to identify two separate homing signals (i.e., they could detect the signal from the crevasse PLB as well as the surface PLB) and felt they could determine the location of the PLBs to within a few meters.

Results: The use of the homing capability of the PLB permits aircraft on-site to locate the precise position of the PLB.

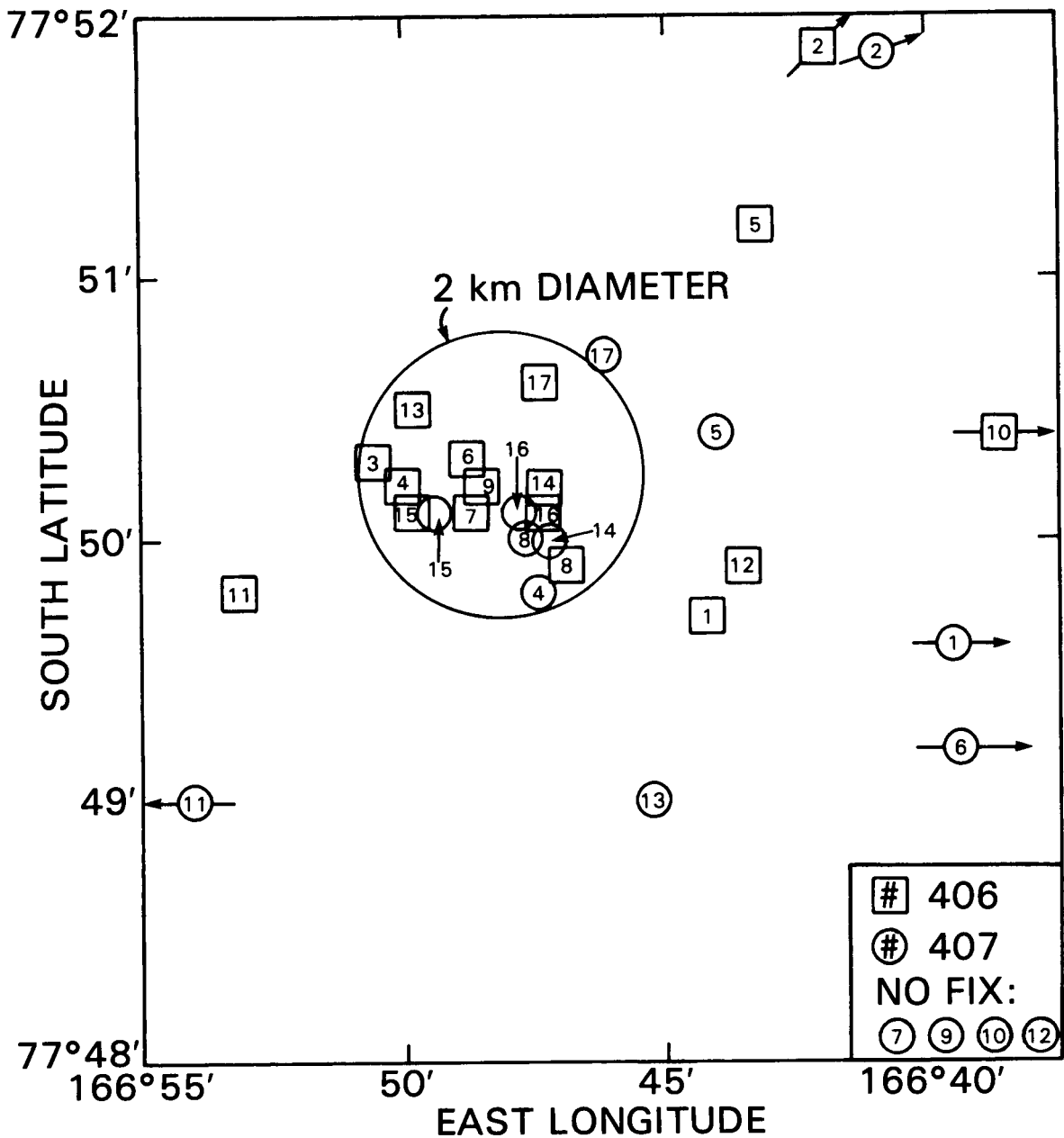

Figure 13. Calculated PLB locations for Test #6. Symbols are as described in Figure 2.

RESPONSE TIME

The alert messages received at McMurdo contained a number of time marks which permitted a breakdown of response times for different segments of the alert network. Included in the messages were the time of closest approach of the satellite, the time the alert was received at the ground station, the time the Autodin message was initiated at Scott AFB, and the time the message was received in McMurdo. From these times, the response times for the SARSAT system (satellite to Scott AFB) and the response time for the Autodin system (Scott AFB to McMurdo) were calculated. The response time within Scott AFB (i.e., receipt of alert to initiation of Autodin message) was usually 1 minute and never more than 2 minutes. Figure 14 summarizes the response times of the two systems for all alerts.

TIME INTERVAL (hr)	PLB TO SCOTT AFB	SCOTT AFB TO MCMURDO
0-1/2		xx
1/2-1		xxxxx
1-1 1/2	xxxxxxxxxxxxxxxxxxxxxxxxxxxxxxxx	xxxxx
1 1/2-2	xxxxxxxxxxxxxxxxxxxxxxxxxxxxxxxx	xxxxxxxxx
2-2 1/2		xxxxxxxxxxxxxxxx
2 1/2-3		xxx xxxx
3-3 1/2		xxx xxxxx
3 1/2-4		xxx xxxx
4-4 1/2		xxxxx
4 1/2-5		xxx xxxx
5-5 1/2		xxxx xxx
5 1/2-6		xx xxx
6-6 1/2		xxx
6 1/2-7		
7-7 1/2		xxxx
7 1/2-8		xx
8-8 1/2		xxx x
8 1/2-9		xxxx
9-9 1/2		x x
9 1/2-10		xx
> 10		x x

Figure 14. Histogram of response times for all alerts. Response times for PLB to Scott AFB and Scott AFB to McMurdo are presented separately.

Over 60% of the SARSAT responses were 2 hours or less (70% less than 2.5 hours). The minimum response time of 1 hour was forced by the fact that all receiving ground stations are located in the Northern Hemisphere. (There are plans for some new ground stations to be located in the Southern Hemisphere.) In general, the longer delays in the SARSAT response were primarily from passes where the receiving ground station was located in the Eastern Hemisphere. In particular, the C2 and C3 alerts would often pile up and two or three would be relayed to Scott AFB together. While such delays are reason for concern for single passes, the frequency of passes in the Antarctic mollifies the impact of alert delays for a single pass on the eventual notification of rescue forces from subsequent SARSAT passes. Another way of stating this is that because the alerts come to Scott AFB from a worldwide network of receiving stations, delays along any single link from one of these receiving stations to Scott AFB will not affect the response time between the other receiving stations and Scott AFB.

By contrast, the Autodin system is a single pipeline which must carry not only all the Antarctic SARSAT messages, but also all U.S. military communications. In addition, when the message for McMurdo reached Christchurch, New Zealand, an operator had to visually identify the message before forwarding the message to McMurdo. Figure 14 shows that the response time for the Autodin system (Scott AFB to McMurdo) was more erratic than the SARSAT response. While there were two cases of responses less than

30 minutes, the mean response time was 3.5 hours. Unlike the SARSAT system, the response time would change slowly with time: when it was slow for one pass, it was slow for a number of passes. This relates back to the single pipeline character of Autodin. When the Autodin system was handling a lot of messages, all messages were handled slower. Backlogs of message traffic are known to have occurred. The extreme case occurred for the final few hours of Test #6 when no Autodin messages were reaching McMurdo at all; a situation that lasted over 48 hours.

RECOMMENDATIONS

Based on the experience gathered from the field tests described in this report, the following recommendations are made:

1. SARSAT Personal Locator Beacons (PLB) are a viable means of alerting rescue forces in McMurdo Station of the presence of an emergency situation and the location of that emergency;
2. Operational use of PLBs by Antarctic field parties should be considered immediately as a means of increasing the safety of Antarctic field operations;
3. Because PLB locations are unreliable when line-of-sight between PLB and satellite is not achieved (especially when the signal must pass through wet snow), each separate field party should be issued two PLBs to insure that in case of an accident, one PLB can be activated from the surface;
4. Response time of the Autodin link (Scott AFB to McMurdo) is unacceptably long for actual emergency situations. It is suggested that while this link be kept, other alternatives, such as INMARSAT or other satellite telecommunication, be investigated;
5. Additional tests of PLB performance should be run in blizzard conditions and with PLBs modified to operate at temperatures below -20°C (these would require a different power source).



Report Documentation Page

1. Report No. NASA TM-4008		2. Government Accession No.		3. Recipient's Catalog No.	
4. Title and Subtitle Antarctic Field Tests of SARSAT Personal Locater Beacons				5. Report Date October 1987	
				6. Performing Organization Code 671.0	
7. Author(s) Robert Bindschadler				8. Performing Organization Report No. 87B0470	
				10. Work Unit No.	
9. Performing Organization Name and Address Goddard Space Flight Center Greenbelt, Maryland 20771				11. Contract or Grant No.	
				13. Type of Report and Period Covered Technical Memorandum	
12. Sponsoring Agency Name and Address National Aeronautics and Space Administration Washington, D.C. 20546-0001				14. Sponsoring Agency Code	
				15. Supplementary Notes	
16. Abstract Field tests of SARSAT personal locator beacons were conducted in the Antarctic to assess the viability of using these beacons to increase the safety of Antarctic field parties. Data were collected on the extent to which dry or wet snow, melting conditions, crevasse walls and snow bridges affected the ability of the SARSAT satellite to calculate an accurate position of the beacon. Average response time between beacon turn-on and alert reception in McMurdo was between 4 and 5 hours for these tests. It is concluded that the SARSAT system is viable for Antarctic operations and it is recommended that it be implemented for future field operations. Because obstruction of line-of-site between beacon and satellite degrades the accuracy of the location calculation (particularly in wet snow), it is further recommended that field parties have sufficient numbers of beacons to insure that in an emergency, one will be able to operate from the surface.					
17. Key Words (Suggested by Author(s)) SARSAT Antarctica Search and Rescue			18. Distribution Statement Unclassified-Unlimited Subject Category 42		
19. Security Classif. (of this report) Unclassified		20. Security Classif. (of this page) Unclassified		21. No. of pages 20	22. Price A02