

NASA Technical Memorandum 100676

# Spectrometric Test of A Linear Array Sensor

Kenneth S. Brown  
Moon S. Kim

JANUARY 1987

**NASA**

## INTRODUCTION

During the past 3 years at GSFC, ground truth biomass reflectivities and upwelling solar spectral irradiance have been measured with a linear array type spectroradiometer. The spectral wavelength precision of this instrument cannot be readily changed nor internally checked during normal use. The spectral calibration relies mainly on the critical alignment of the optical components which are initially set and calibrated at assembly. To test the accuracy of the wavelength calibration an apparatus was employed using a minimum of equipment and data sampling. It consisted of a Quartz-Halogen lamp and calibrated monochromator. The monochromatic light output of the system was selected at eight points to cover the range of the spectroradiometer which was from 360 to 1050 nm. From the results of these observations an intercomparison was made to a calibration performed by another lab; the slight average difference, approximately 4 nm per channel, appears acceptable for most reflective remote sensing studies.

## FIELD-PORTABLE SPECTRORADIOMETER, MODEL SE 590

The spectroradiometer under test is a portable commercial unit which collects irradiance and reflectivity data as a hand-held or helicopter mounted system. Its spectrographic mechanism combines refracting optics with a reflective grating and an array detector. Light enters the sensor thru an aperture slit with a 10 degree field of view. A 300 groove/mm holographic grating blazed at 5000 Å disperses the light onto a 256 element silicon linear array photodiode. The detector responds as 256 contiguous individual spectral bandpass channels within an approximate range of 400 to 1050nm. Each channel has a channel address associated with its location on the array. These consecutively ordered addresses correspond to the channel wavelength. The amplitude of the response of the 256 elements is read into a register at a location corresponding to the channel address. This information can be reviewed on the internal 4-digit hexadecimal LED display. The digital amplitude quantization of the amplitude is 12 bits. The data in 12 bit form can be stored on media with sequential order maintaining the channel address. To convert the channel address to spectral wavelength an address vs wavelength chart (to one decimal place in nm) is provided. This chart was used for the comparison with the test data.

## SET UP

The test apparatus shown in Figure 1 inputs monochromatic light into the system. It consists of a light source and a monochromator. Ideally, the response to the test apparatus would be an amplitude signal in a single channel consequently the monochromator throughput bandwidth would have to be narrower than the channel bandpass. In reality most monochromator half-band signals will spread across several channels, but usually one channel will respond to the light more than adjacent channels will. To locate the radiometer with respect to the output aperture of the monochromator, it is best to mount it on a translational stage moving across the dispersed light path.

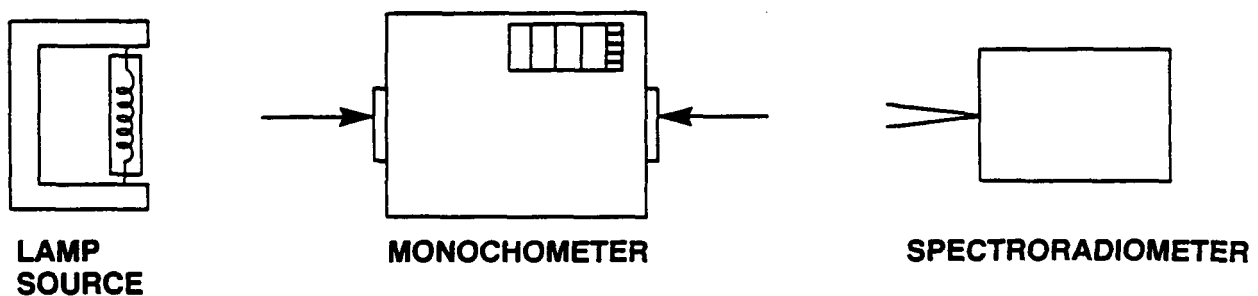

Figure 1. Test set up

Movement will shift the frequency component of light and a central channel position can be located. Moving the source has little effect on the setup wavelength but it does change the signal amplitude. The light apparatus was calibrated by checking the monochrometer wavelength scale against the 536.1nm Hg line in accordance with the procedure outlined in the monochrometer manual.

#### A. SOURCE MONOCHROMETER

The calibration monochrometer is a Jarrell-Ash Monospec 27 which features a crossed Czerny-Turner design (see Appendix A for detailed specifications.) For this set up, 150 micron slits and a 1200 g/mm ruled 520nm blazed grating were installed. The monochrometer readout and wavelength control were somewhat unusual. Commonly the readout is the same as the wavelength output, however on this unit the gearing is such that the output is one-fourth the dial setting. Since four digits and a vernier could be read, it was possible to adjust the wavelength to  $\pm 0.05\text{nm}$ .

#### B. LIGHT SOURCE

A Quartz-Halogen lamp was used as a source. Its specifications are listed in Appendix B.

### DATA COLLECTION

By stepping the monochrometer in intervals of 100nm, channels throughout the spectroradiometer range were exposed. Using this procedure, eight data points, as shown in Table 1, were observed. The wavelength read off the monochrometer is listed in the third column of the table. Corresponding to this is the radiometric data from the sensor which includes the hexadecimal channel address and the response value. Wavelength settings of .8, .9, and 1.0 produced two regions of response, due to a higher order grating effect. A typical case of instrument response to a spectral setting is shown in Figure 2. The abscissa is the decimal signal level and the ordinate is the hexadecimal channel address. Notice that there is a maximum signal level which is significantly higher than the levels of adjacent channels. By narrowing the slit size of the monochrometer it may be possible to limit the response of the adjacent channels (provided the source intensity is high enough) which would increase the accuracy. An additional set of data was taken using the low pressure Mercury lamp emission spectra. This data is shown in Appendix C.

### RESULTS

A curve of wavelength vs channel address number appears with the plotted data points in Figure 3. The linear regression and the data point statistics are briefly summarized in Figure 4. As expected, the greatest residual for the linear regression is two and a half channels, and the smallest, two-tenths of a channel. The RMS deviation is .57, approximately half a channel. An analysis of the data complete with scatter plot, variance analysis, regression coefficients, residuals, and confidence limits appears in Appendix D. From the algorithm the central wavelengths for all channel addresses was calculated, these appear in Table 2. Slight differences between the data in the table and the test data are due to the deviation between the regression curve and the raw data.

### DISCUSSION

Comparison of the data with a calibration performed on a similar unit as shown in Table 3 resulted in a maximum difference of three channels or 8.9nm at channel 79. The least difference was at channel 99: 1 channel or 3.0nm. The average error between data sets is 4.4 nm. Obviously the two instruments will have slightly

different calibrations by virtue of assembly tolerances. And some error will be introduced in the testing. It is difficult to place a numeric value on spectral wavelength error when measuring reflectivity in support of broad-band satellite remote sensor investigations, but 4nm seems reasonable compared to thematic mapper channel bandpasses which are on the order of 50 to 70 nm.

The question of set up and test error and the accuracy achieved when only taking eight samples is a significant concern however answers depend on the nature of the investigation for which the SE 590 is being used. It is recognized that results from this test may be unacceptable for defining the channel wavelengths in some ground truth experiments. For those cases this test serves as a guide to determining the performance limits, the wavelength resolution and set up accuracy. Remember, from this test it is known that the channel address vs spectral wavelength curve is linear; That the range is approximately 400 to 1100 nm.; and that a setup with a third of a meter monochromator can produce an RMS deviation of less than one channel with only a few samples. Of course, with more care in taking data the deviation of this simple setup can be improved: a good procedure is to take sets of observations at three points within the wavelength range; a set near each range end and in the middle. The number of observations in a set must be sufficiently large to meet gaussian conditions, say 16 to 30 provided the measurement procedure allows the wavelength to be manually aligned so it too can act as a variable. If better accuracy is needed, then the slits governing input wavelength shape can be decreased for better performance sensitivity. This high resolution set up can be used to investigate other spectral characteristics such as crosstalk and address bandpass (provided they impact the interpretation of the study data). Clearly sufficient flexibility in set up and data collection is possible to meet more exacting accuracy requirements.

This test did make inroads into the characterization of the spectroradiometer. The test observation points were primarily selected in preparation for a test of radiometric sensitivity at field level integration time and operating conditions. The next test is determining the radiometric response function and applying it to typical data such as the solar spectral irradiance off a high reflectance plate and a off a two day old snow cover. The test should also produce information on the system noise, linearity, responsivity and sensitivity.



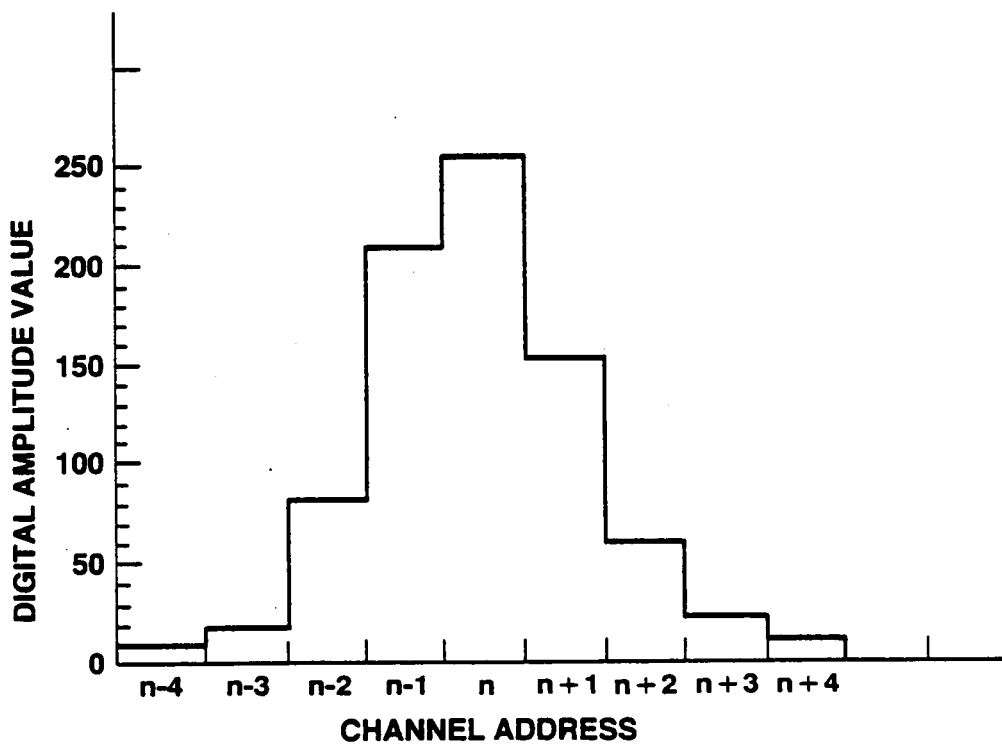

Figure 2. Typical signal response to narrow bandpass light from apparatus

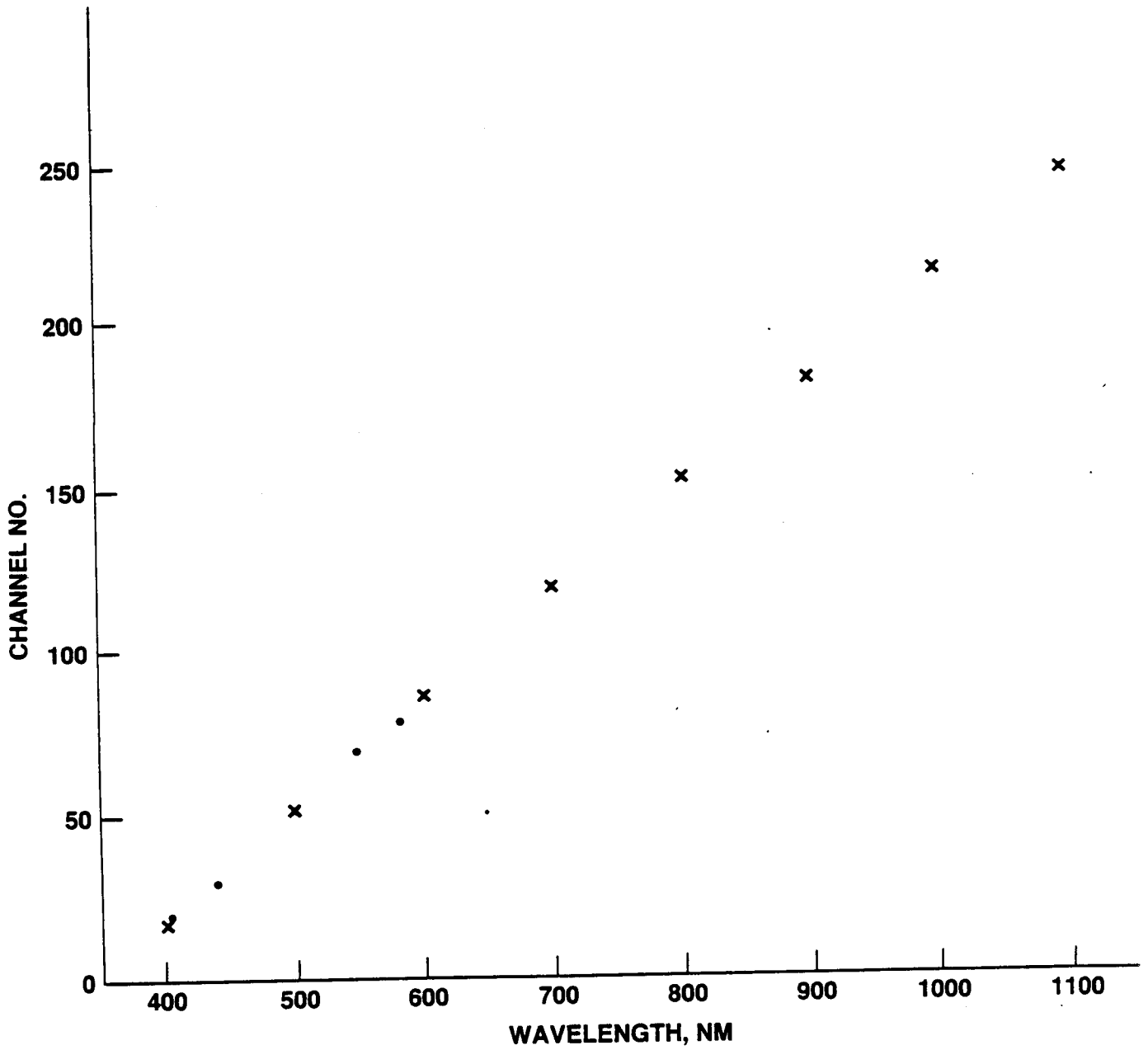
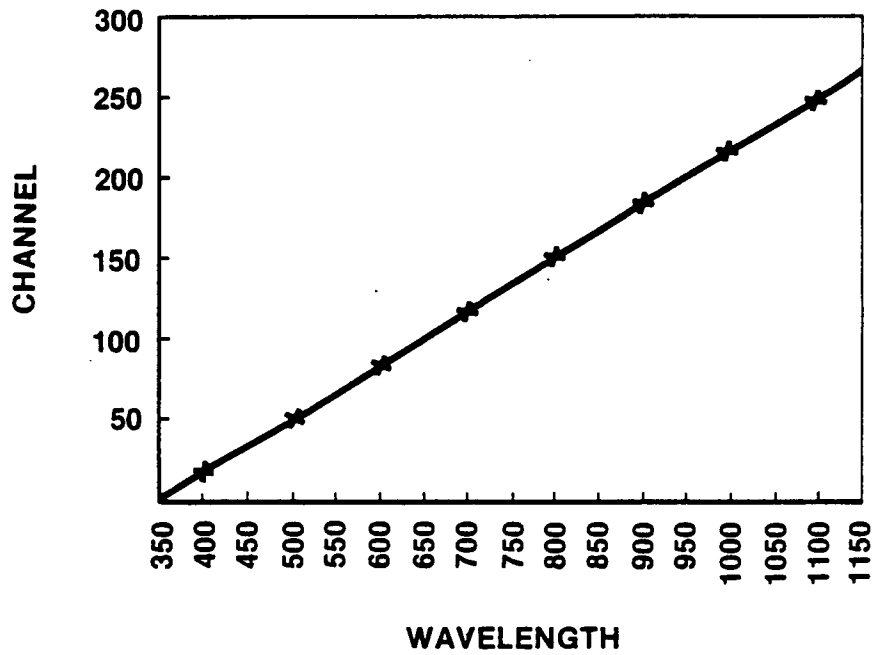

Figure 3. Spectral response curve



(a) LINEAR REGRESSION CURVE:

$$\text{CHANNEL} = 0.33333 \times \text{WAVELENGTH} - 116.00000$$

OBS#	Observed Y	Predicted Y	Residual	Standardized Residual
1	15.00000	17.33333	-2.33333	-1.18322
2	50.00000	50.66667	-.66667	-.33806
3	85.00000	84.00000	1.00000	.50709
4	119.00000	117.33333	1.66667	.84515
5	153.00000	150.66667	2.33333	1.18322
6	185.00000	184.00000	1.00000	.50709
7	217.00000	217.33333	-.33333	-.16903
8	248.00000	250.66667	-2.66667	-1.35225

(b) TABLE OF CALCULATED RESIDUALS

Figure 4. Linear Regression Data



Table 2. Channel Address Center Wavelength  
(Calculated from Linear Regression in Figure 4)

Channel #	Wavelength nm	Channel #	Wavelength #	Channel #	Wavelength #
04	360.52	46	486.47	88	612.43
05	363.52	47	489.47	89	615.43
06	366.51	48	492.47	90	618.43
07	369.51	49	495.47	91	621.43
08	372.51	50	498.47	92	624.42
09	375.51	51	501.47	93	627.42
10	378.51	52	504.47	94	630.42
11	381.51	53	507.47	95	633.42
12	384.51	54	510.46	96	636.42
13	387.51	55	513.46	97	639.42
14	390.51	56	516.46	98	642.42
15	393.51	57	519.46	99	645.42
16	396.51	58	522.46	100	648.42
17	399.50	59	525.46	101	651.41
18	402.50	60	528.46	102	654.41
19	405.50	61	531.46	103	657.41
20	408.50	62	534.46	104	660.41
21	411.50	63	537.45	105	663.41
22	414.50	64	540.45	106	666.41
23	417.50	65	543.45	107	669.41
24	420.50	66	546.45	108	672.41
25	423.49	67	549.45	109	675.41
26	426.49	68	552.45	110	678.41
27	429.49	69	555.45	111	681.40
28	432.49	70	558.45	112	684.40
29	435.49	71	561.45	113	687.40
30	438.49	72	564.45	114	690.40
31	441.49	73	567.44	115	693.40
32	444.49	74	570.44	116	696.40
33	447.49	75	573.44	117	699.40
34	450.49	76	576.44	118	702.40
35	453.48	77	579.44	119	705.40
36	456.48	78	582.44	120	708.39
37	459.48	79	583.44	121	711.39
38	462.48	80	588.44	122	714.39
39	465.48	81	591.44	123	717.39
40	468.48	82	594.43	124	720.39
41	471.48	83	597.43	125	723.39
42	474.48	84	600.43	126	726.39
43	477.48	85	603.43	127	729.39
44	480.47	86	606.43	128	732.39
45	483.47	87	609.43	129	735.39

Table 2 (Con't.): Channel Address Center Wavelength  
(Calculated from Linear Regression in Figure 4)

Channel #	Wavelength nm	Channel #	Wavelength #	Channel #	Wavelength #
130	738.38	172	864.34	214	990.30
131	741.38	173	867.34	215	993.30
132	744.38	174	870.34	216	996.29
133	747.38	175	873.34	217	999.29
134	750.38	176	876.34	218	1002.29
135	753.38	177	879.34	219	1005.29
136	756.38	178	882.33	220	1008.29
137	759.38	179	885.33	221	1011.29
138	762.38	180	888.33	222	1014.29
139	765.37	181	891.33	223	1017.29
140	768.37	182	894.33	224	1020.29
141	771.37	183	897.33	225	1023.28
142	774.37	184	900.33	226	1026.28
143	777.37	185	903.33	227	1029.28
144	780.37	186	906.33	228	1032.28
145	783.37	187	909.32	229	1035.28
146	786.37	188	912.32	230	1038.28
147	789.37	189	915.32	231	1041.28
148	792.37	190	918.32	232	1044.28
149	795.36	191	921.32	233	1047.28
150	798.36	192	924.32	234	1050.28
151	801.36	193	927.32	235	1053.27
152	804.36	194	930.32	236	1056.27
153	807.36	195	933.32	237	1059.27
154	810.36	196	936.32	238	1062.27
155	813.36	197	939.31	239	1065.27
156	816.36	198	942.31	240	1068.27
157	819.36	199	945.31	241	1071.27
158	822.36	200	948.31	242	1074.27
159	825.35	201	951.31	243	1077.27
160	828.35	202	954.31	244	1080.26
161	831.35	203	957.31	245	1083.26
162	834.35	204	960.31	246	1086.26
163	837.35	205	963.31	247	1089.26
164	840.35	206	966.30	248	1092.26
165	843.35	207	969.30	249	1095.26
166	846.35	208	972.30	250	1098.26
167	849.35	209	975.30	251	1101.26
168	852.34	210	978.30	252	1104.26
169	855.34	211	981.30	253	1107.26
170	858.34	212	984.30	254	1110.25
171	861.34	213	987.30	255	1113.25

Table 3. Comparison of results with test of November 1981

Wavelength nm	This Test Channel #	Old Test Channel #	Channel Difference #	Wavelength Difference #
400 nm	OF 15	OD 13	2	5.0 nm
500 nm	32 50	33 51	1	2.7 nm
600 nm	55 85	57 87	2	5.8 nm
700 nm	77 119	79 121	2	5.9 nm
800 nm	99 153	9A 154	1	3.0 nm
900 nm	B9 185	BA 186	1	3.2 nm
1000 nm	D9 217	DA 218	1	3.1 nm
1100 nm	F8 248	F9 249	1	3.2 nm

## Appendix A

## 2.2 Identification of Components

After unpacking the MonoSpec 27, take time to become familiar with its major components. Figure 1 and Figure 2 identifies the various components of the instrument.

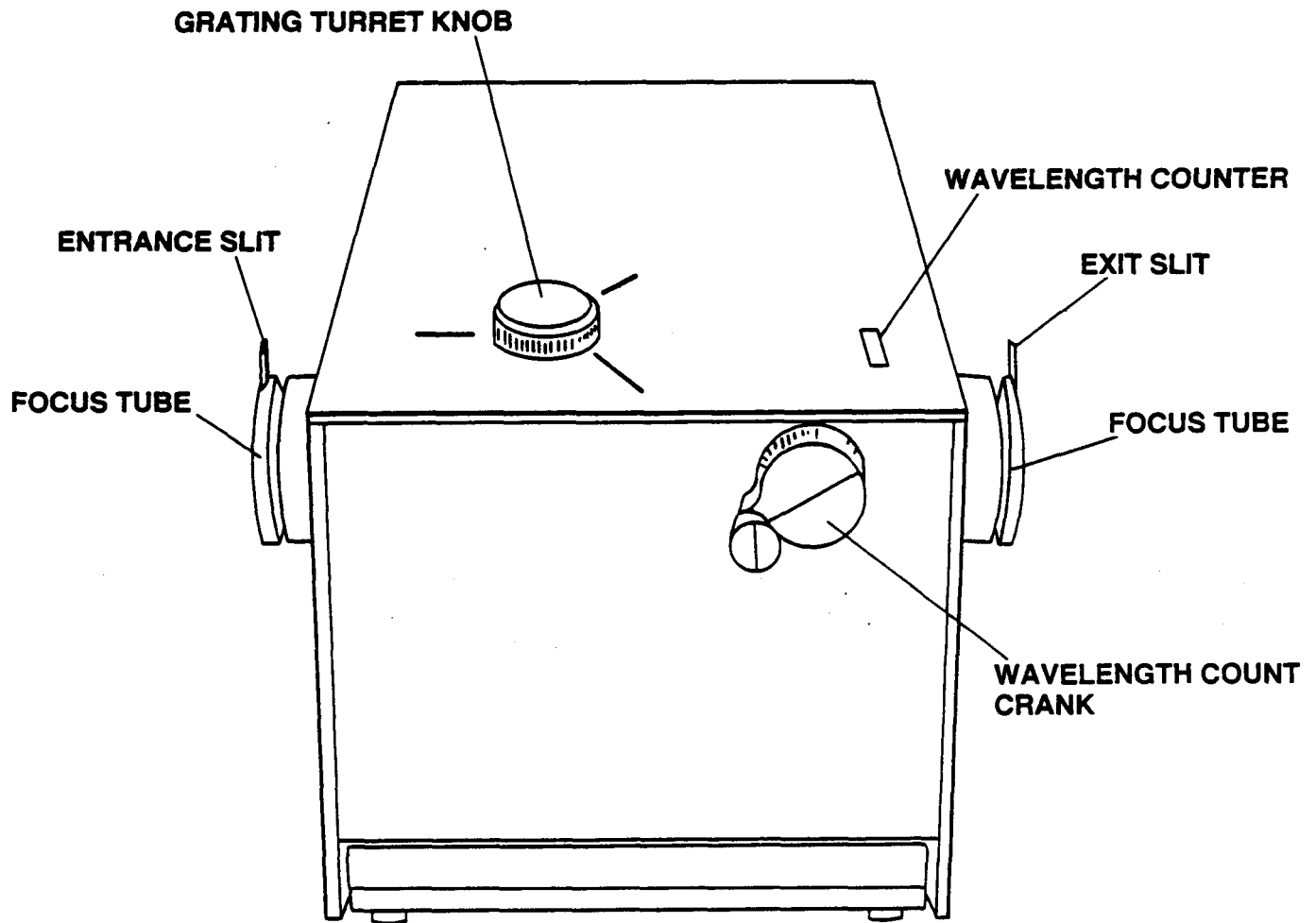

Figure 1. Major components of the MonoSpec 27 Monochromater.

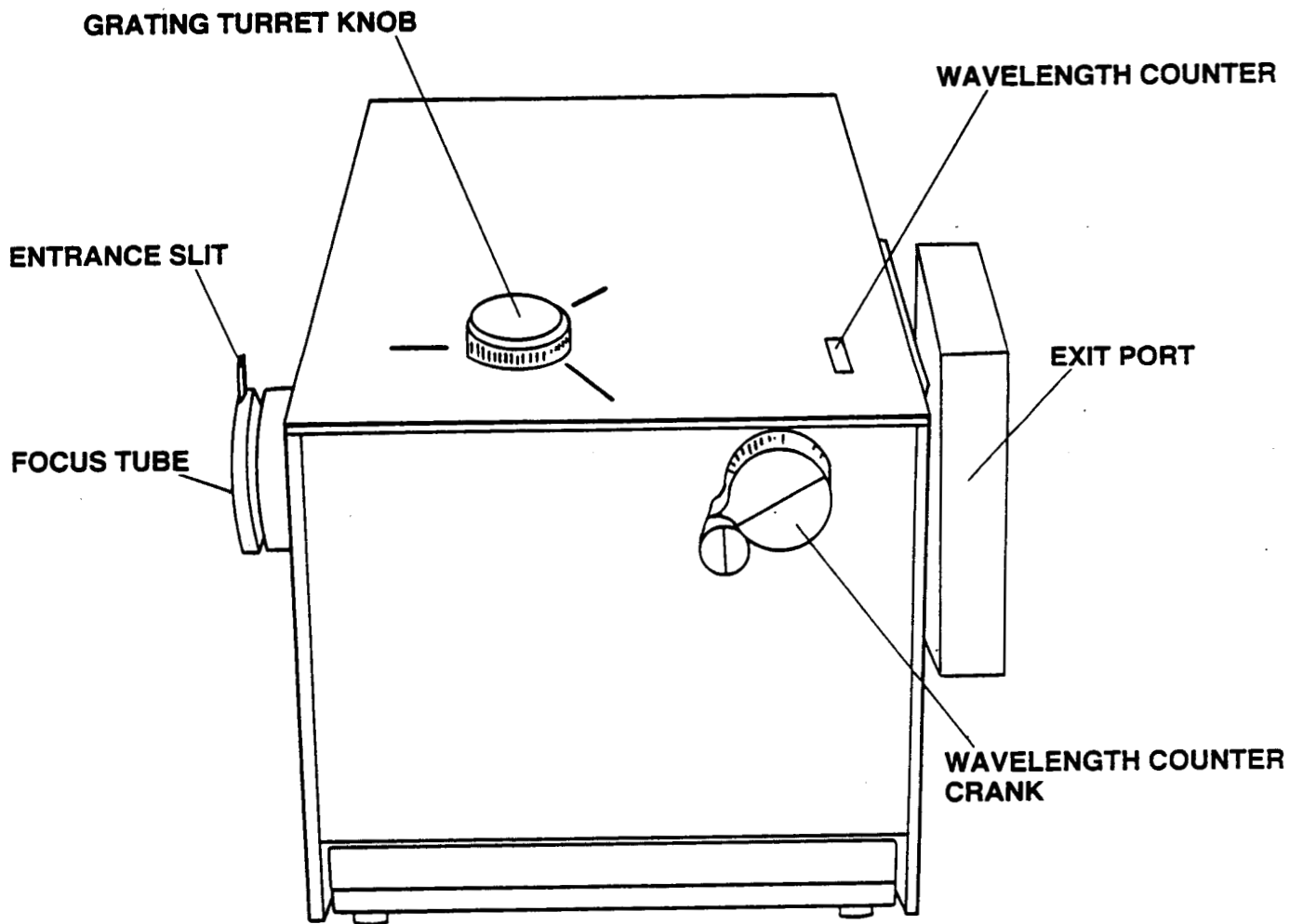

Figure 2. Major components of the MonoSpec 27 Spectrograph.

### 3.0 OVERVIEW

#### 3.1 Physical Specifications

Length: 16 1/8 in. (41 cm)  
Width: 7 1/2 in. (19 cm)  
Height: 6 3/4 in. (17 cm)  
Weight: 20 lb (9 kg)  
Focal Length: 275 mm  
Focal Ratio: f/3.8  
Stray Light Levels: 0.05% at 500 nm using an incandescent lamp & high pass filter. 0.001% at 10 nm away from the 632.8 nm laser line.

Entrance and exit slit dimensions: Fixed 18 mm high, 25 to 2000. Variable 10 to 2000 and 15 mm high.

Readout: One 4-digit Veeder-Root, counter reading from 0 to 1000 nm for the 1200g/mm grating.

Grating size, spectral range, and dispersion:

Ruling (g/mm)	Blaze	Range	Dispersion (nm/mm)
2400	350 nm	190-450 nm	1.5
2400	260 nm	200-450 nm	1.5
1800	550 nm	300-600 nm	2.0
1200	520 nm	380-900 nm	3.0
1200	400 nm	300-900 nm	3.0
1200	300 nm	190-600 nm	3.0
600	500 nm	480- 1.2	6.0
600	450 nm	300-900 nm	6.0
600	1.0	750-1.8	6.0
300	2.0	1.3-3.6	12.0
150	4.0	3.6-7.2	24.0
100	6.5	4.5-10.8	36.0
50	10	7.0-21	72.0
30	30	21-40	120.0

Resolution\*

Slit width ( m)	Slit height (mm)	Resolution (nm)
150	18	0.8
50	18	0.5
25	5	0.3

Holographic Gratings

Spacing g/mm	Range	Dispersion nm/mm
2400 g/mm blaze,	190-450	1.5
1800 g/mm blaze,	190-700	2.0
1200 g/mm blaze,	250-900	3.0
600 g/mm blaze,	300-900	6.0
300 g/mm blaze,	200-800	12.0
150 g/mm blaze,	200-800	24.0

\*With 1200 grooves/mm grating and various slit widths and heights.



### 3.2 Optical Design

The MonoSpec 27 uses a crossed Czerny-Turner design to minimize re-entry spectra. Light passes through the entrance slit and follows the path shown in Figure 3.

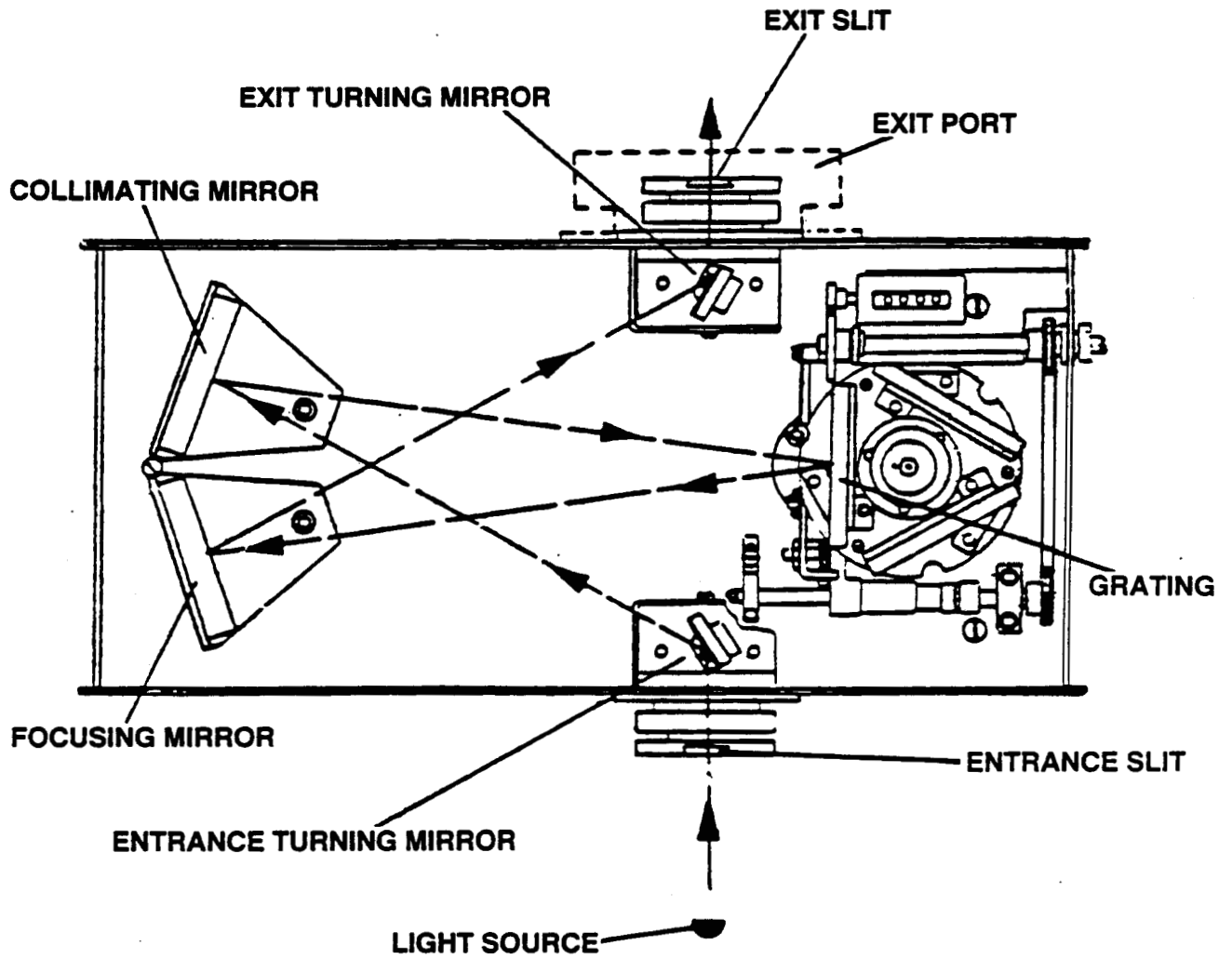
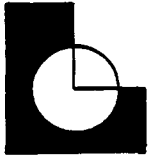

Figure 3. Light path through the optical system.

## Appendix B



# OPTRONIC LABORATORIES, INC.

Emphasizing Precision and Accuracy

MODEL 100

## ONE SOLAR CONSTANT STANDARD

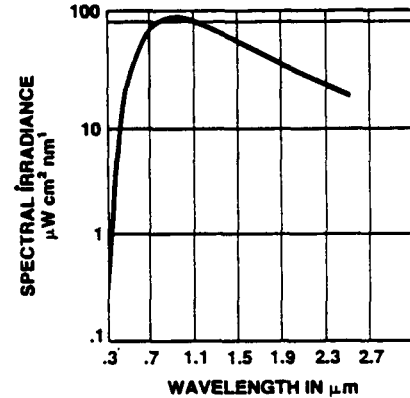
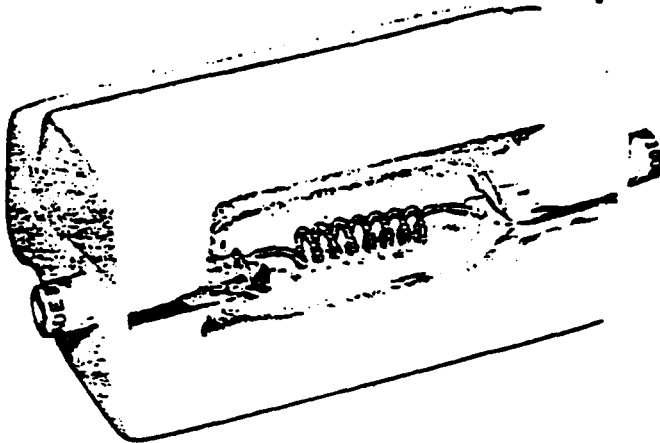

### HIGH INTENSITY STANDARDS OF TOTAL AND SPECTRAL IRRADIANCE

#### GENERAL DESCRIPTION

The high-intensity standards consist of 1000-watt tungsten-halogen lamps mounted in slip-cast, fused-silica reflectors. The source has an effective radiating area of 3 by 5 cm. and generates a total irradiance on the order of a solar constant (about 136 mW/cm<sup>2</sup>) when used at a distance of 40 cm. Uniformity tests performed on a number of these units show that the irradiance in the specified direction over an area of 4 cm<sup>2</sup> is uniform to ±0.25%.

The standards can be obtained with calibrations for total irradiance, spectral irradiance, and illuminance. All calibrations are based on standards supplied by the National Bureau of Standards with the spectral measurements based on the NBS 1973 spectral irradiance scale.

#### OPTICAL ACCESSORIES

Model 56 Lamp Holder  
 Model 83 and 83DS Constant Current DC Power Supplies  
 (see Bulletin 32)

BULLETIN 3R

#### SPECIFICATIONS

Operating Current (set)	8.00 amperes DC
Voltage (nominal)	115 volts
Total Irradiance (nominal)	136 mW/cm <sup>2</sup>
Nominal Irradiance at 1000 nm	100 μW/cm <sup>2</sup> nm
Illuminance (nominal)	3 lumens/cm <sup>2</sup> (3000fc)
Long Term Stability	50 hours for ± 1% change

The following table gives the type of calibrations and the corresponding model number for these standards.

TYPE OF CALIBRATION	MODEL NO.
Spectral Irradiance (300-750 nm)	100A
Spectral Irradiance (750-2500 nm)	100B
Spectral Irradiance (300-2500 nm)	100C
Total Irradiance	100D
Total and Spectral (300-2500 nm)	100H
Photometric (only)*	100P
Seasoned, Uncalibrated	100

\*For photometric calibrations in addition to the above calibrations, add the suffix "P" to the appropriate model number.

730 CENTRAL FLORIDA PARKWAY • ORLANDO, FL 32809 • (305) 857-9000

## Appendix C

Table 1. 590 Spectroradiometer data using mercury lamp source

Wave-length REF, nm	Data ID # on Tape	Inter-grading Time: (X/60) Second	Wave-length ( $\lambda$ ), nm	Channel #, Hex. No. Peak Value, in Hex. No. (Range of Value: 04 to FE)
404.6	Side A 0002	64	404.6 nm	11 12 13 14 15 16 17 06 0C 16 18 0F 08 05
435.8	A 0003	32	436.0 nm	1A 1B 1C 1D 1E 1F 20 21 22 07 08 4F 85 76 3A 15 0A 06
546.1	A 0004	64	546.1 nm	40 41 42 43 44 45 46 47 48 49 06 08 1E 71 98 59 21 0E 08 06
576.9	A 0005	64	577.25 nm	4C 4D 4E 4F 50 51 52 53 54 05 0A 1C 4C 7B 5A 20 0D 07
578.9	A 0006	64	578.75 nm	4C 4D 4E 4F 50 51 52 53 54 06 0F 2F 54 4B 25 0E 08 05
808.2	A 0007	64	812.0 nm	11 12 13 14 15 04 05 05 05 04

## Appendix D

---

DATA MANIPULATION

---

SPECTRAL CALIBRATION

Data file name:

Date type is: Raw data

Number of observations: 8

Number of variables: 2

Variable names:

1. WAVELENGTH

2. CHANNEL

SPECTRAL CALIBRATION

Data type is: Raw data

	Variable #1 (WAVELENGTH)	Variable #2 (CHANNEL )
OBS #		
1	400.00000	15.00000
2	500.00000	50.00000
3	600.00000	85.00000
4	700.00000	119.00000
5	800.00000	153.00000
6	900.00000	185.00000
7	1000.00000	217.00000
8	1100.00000	248.00000

---

POLYNOMIAL REGRESSION ON DATA SET:

SPECTRAL CALIBRATION

---

—where: Dependent variable = (2) CHANNEL  
Independent variable = (1) WAVELENGTH

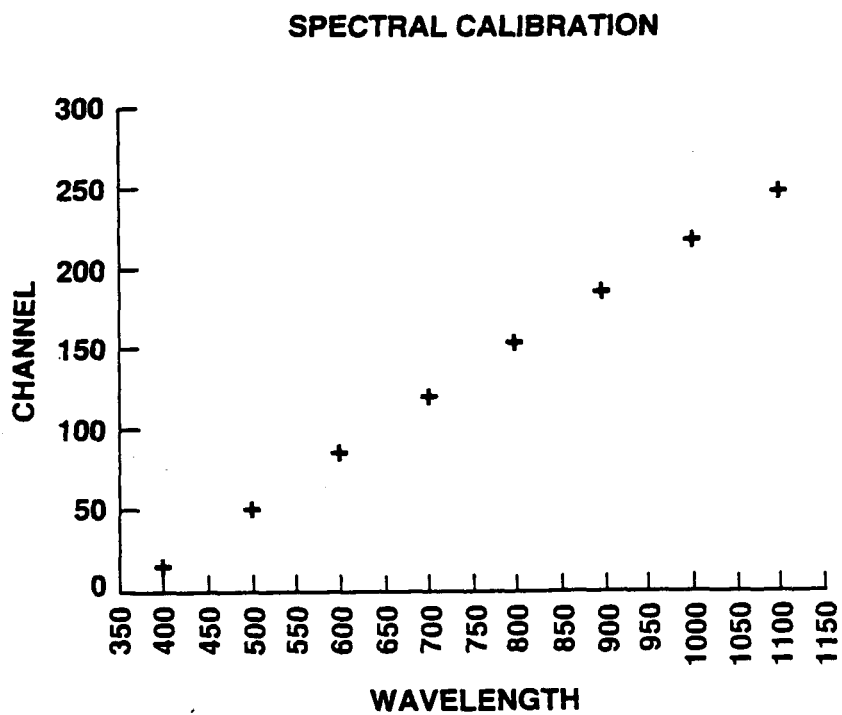



VARIABLE	N	MEAN	VARIANCE	STANDARD DEVIATION	COEFF. OF VARIATION
WAVELENGTH	8	750.00000	60000.00000	244.94897	32.65986
CHANNEL	8	134.00000	6670.00000	81.67007	60.94781

CORRELATION = .99975

PRELIMINARY AOV

SOURCE	SS (ADDITIONAL)	F-VALUE	DF	R <sup>2</sup> (CUMULATIVE)
TOTAL (ADJ)	46690.00000			
X <sup>1</sup>	46666.66667	12000.000	(1,6)	.9995

SELECTED DEGREE OF REGRESSION = 1  
R-SQUARED = .99950  
STANDARD ERROR OF ESTIMATE = 1.97202659436

ANALYSIS OF VARIANCE TABLE

SOURCE	DF	SUM OF SQUARES	MEAN SQUARE	F-VALUE
TOTAL	7	46690.00000		
REGRESSION	1	46666.66667	46666.66667	12000.00
X <sup>1</sup>	1	46666.66667	46666.66667	12000.00
RESIDUAL	6	23.33333	3.88889	

REGRESSION COEFFICIENTS

STANDARD ERROR

VARIABLE	STD. FORMAT	E-FORMAT	REG. COEFFICIENT	T-VALUE
CONSTANT	-116.00000	-.116000000000E+03	2.38630	-48.61
X <sup>1</sup>	.33333	.333333333333E+00	.00304	109.54

98% CONFIDENCE INTERVAL

	COEFFICIENT	LOWER LIMIT	UPPER LIMIT
CONSTANT	-116.00000	-123.50040	-108.49960
X <sup>1</sup>	.33333	.32377	.34290

## SPECTRAL CALIBRATION

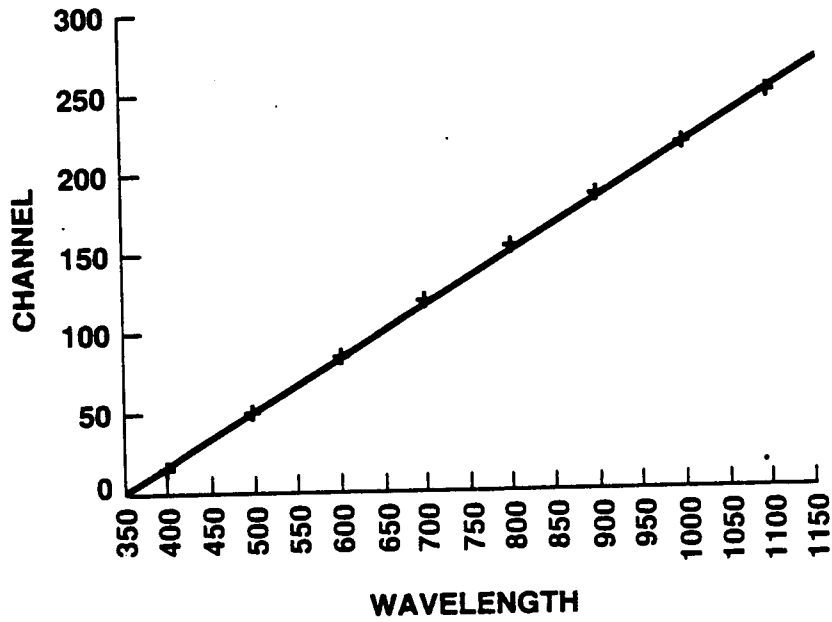

### TABLE OF RESIDUALS

OBS#	OBSERVED Y	PREDICTED Y	RESIDUAL	STANDARDIZED RESIDUAL	SIGNIF.
1	15.00000	17.33333	-2.33333	-1.18322	
2	50.00000	50.66667	-.66667	-.33806	
3	85.00000	84.00000	1.00000	.50709	
4	119.00000	117.33333	1.66667	.84515	
5	153.00000	150.66667	2.33333	1.18322	
6	185.00000	184.00000	1.00000	.50709	
7	217.00000	217.33333	-.33333	-.16903	
8	248.00000	250.66667	-2.66667	-1.35225	

Durbin-Watson Statistic: .661904761905

# SPECTRAL CALIBRATION

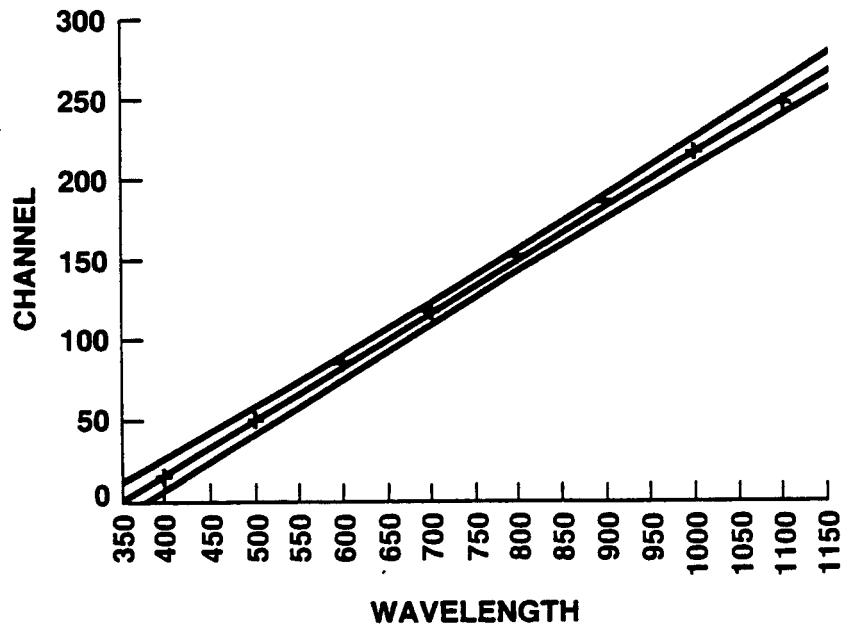

# SPECTRAL CALIBRATION

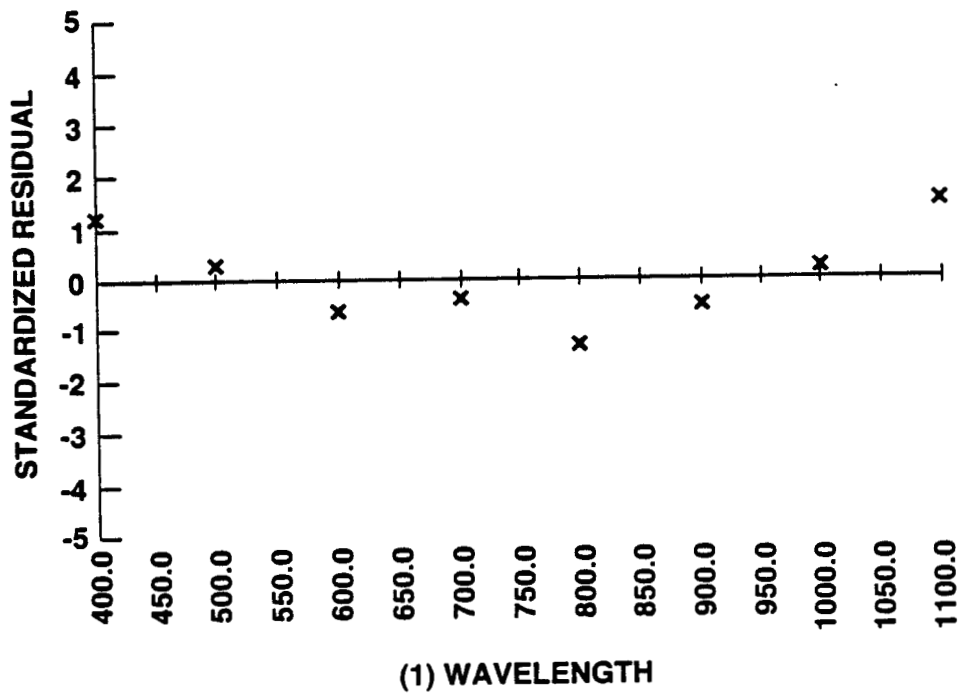
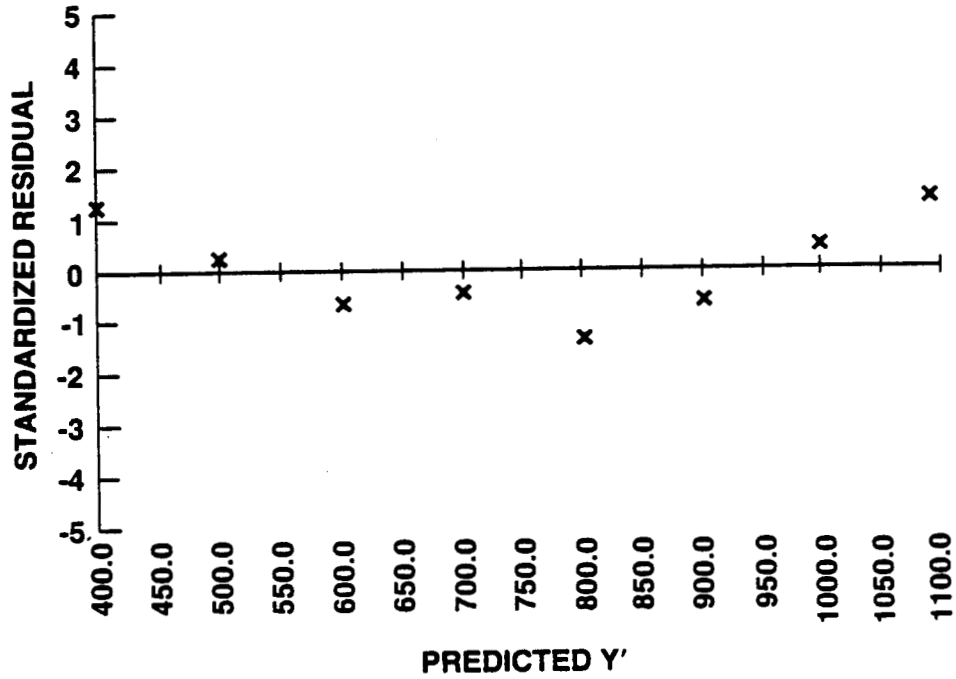

## BIBLIOGRAPHIC DATA SHEET

1. Report No. NASA TM-100676	2. Government Accession No.	3. Recipient's Catalog No.	
4. Title and Subtitle SPECTROMETRIC TEST OF A LINEAR ARRAY SENSOR		5. Report Date January 1987	
		6. Performing Organization Code 625	
7. Author(s) Kenneth S. Brown, Moon S. Kim*		8. Performing Organization Report No. 87B0189	
9. Performing Organization Name and Address Goddard Space Flight Center Greenbelt, Maryland 20771		10. Work Unit No.	
		11. Contract or Grant No.	
		13. Type of Report and Period Covered Technical Memorandum	
12. Sponsoring Agency Name and Address National Aeronautics and Space Administration Washington, D.C. 20546-0001		14. Sponsoring Agency Code	
15. Supplementary Notes *Moon S. Kim is employed by ORI, Inc.; Rockville, Maryland 20850			
16. Abstract  A spectroradiometer which measures spectral reflectivities and irradiance in discrete spectral channels was tested to determine the accuracy of its wavelength calibration. This sensor is a primary tool in the remote sensing investigations conducted on biomass at NASA's Goddard Space Flight Center. Measurements have been collected on crop and forest plants both in the laboratory and field with this radiometer to develop crop identification and plant stress remote sensing techniques. Wavelength calibration is essential for use in referencing the study measurements with those of other investigations and satellite remote sensor datas. This calibration determines a wavelength vs channel address conversion which was found to have an RMS deviation of approximately half a channel, or 1.5nm in the range from 360 to 1050nm. A comparison of these results with those of another test showed an average difference of approximately 4nm, sufficiently accurate for most investigative research.			
17. Key Words (Selected by Author(s)) Spectrometer, Radiometric, Calibration, Linear Array Sensor, Spectroradiometer		18. Distribution Statement Unclassified - Unlimited  Subject Category 43	
19. Security Classif. (of this report) Unclassified	20. Security Classif. (of this page) Unclassified	21. No. of Pages	22. Price*